

**Instruction Manual**

for

**BSA**

**A Models**

## CONTENTS

|   | <i>Page</i> |
|---|-------------|
| <b>BRAKES</b> ... ..                        | 52          |
| Cam Spindles ... ..                         | 52          |
| Front Brake Adjustment ... ..               | 52          |
| Rear Brake Adjustment ... ..                | 52          |
| <b>CARBURATION</b> ... ..                   | 52          |
| Air Cleaner (Swinging Arm) ... ..           | 55          |
| Air Cleaner (A10 Plunger) ... ..            | 55          |
| Carburetter ... ..                          | 52          |
| <b>CLUTCH</b> ... ..                        | 69          |
| <b>CONTROLS</b> ... ..                      | 6           |
| Foot ... ..                                 | 8           |
| Hand ... ..                                 | 7           |
| Miscellaneous ... ..                        | 8           |
| <b>DECARBONISING</b> ... ..                 | 56          |
| Cylinder and Pistons ... ..                 | 60          |
| Dismantling for Top Overhaul ... ..         | 57          |
| Examination of Valves ... ..                | 58          |
| Petrol Tank Removal (Swinging Arm) ... ..   | 56          |
| Petrol Tank Removal (A10 Plunger) ... ..    | 57          |
| Preliminary Work ... ..                     | 56          |
| Reassembling Engine ... ..                  | 63          |
| Reassembling Head ... ..                    | 63          |
| Valve Grinding ... ..                       | 59          |
| Valve Rockers ... ..                        | 60          |
| Valve Springs ... ..                        | 60          |
| <b>DRIVING</b> ... ..                       | 10          |
| <b>ELECTRICAL SECTION</b> ... ..            | 70          |
| Battery ... ..                              | 70          |
| Battery Removal (Swinging Arm) ... ..       | 19          |
| Dynamo ... ..                               | 71          |
| Lamps ... ..                                | 73          |
| Magneto ... ..                              | 72          |
| Wiring Diagram (Swinging Arm Models) ... .. | 76          |
| Wiring Diagram (A10 G.F. Plunger) ... ..    | 77          |
| Wiring Diagram (A10 Road Rocket) ... ..     | 78          |
| <b>ENGINE</b> ... ..                        | 22          |
| Automatic Advance ... ..                    | 29          |
| Cylinder Head ... ..                        | 29          |
| Ignition Timing ... ..                      | 24          |
| Sparking Plugs ... ..                       | 29          |
| Valve Clearances ... ..                     | 22          |
| Valve Timing ... ..                         | 27          |



|  | <i>Page</i> |
|--|-------------|
| <b>GEARBOX</b> ... ..                              | 66          |
| Adjustable (Swinging Arm Models) ...               | 66          |
| Dismantling ... ..                                 | 66          |
| Gear Change Mechanism ... ..                       | 66          |
| Reassembly ... ..                                  | 68          |
| <b>LUBRICATION CHART</b> ... ..                    | 42, 43      |
| <b>LUBRICATION SYSTEM</b> ... ..                   | 14          |
| Ball Valves ... ..                                 | 14          |
| Filters (Swinging Arm Models) ... ..               | 15          |
| Filters (A10 Plungers) ... ..                      | 15          |
| Tank Pressure Release (Swinging Arm Models) ... .. | 15          |
| Tank Pressure Release (A10 Plunger) ...            | 15          |
| <b>PERIODICAL MAINTENANCE</b> ... ..               | 17          |
| Cleaning ... ..                                    | 17          |
| Weekly ... ..                                      | 17          |
| 1,000 Miles ... ..                                 | 19          |
| 2,000 Miles ... ..                                 | 20          |
| <b>PREPARING THE MACHINE</b> ... ..                | 9           |
| <b>RUNNING-IN</b> ... ..                           | 12          |
| <b>SUSPENSION AND STEERING</b> ... ..              | 47          |
| Front Forks ... ..                                 | 47          |
| Rear Suspension (Swinging Arm) ... ..              | 49          |
| Rear Suspension (A10 Plunger) ... ..               | 50          |
| Steering Head ... ..                               | 48          |
| <b>TECHNICAL DATA</b> ... ..                       | 4, 5        |
| <b>TRANSMISSION</b> ... ..                         | 32          |
| Chain Lubrication ... ..                           | 39          |
| Clutch Control ... ..                              | 36          |
| Clutch Spring Pressure (Swinging Arm) ...          | 38          |
| Clutch Spring Pressure (A10 Plunger) ...           | 39          |
| Primary Chain (Swinging Arm) ... ..                | 32          |
| Primary Chain (A10 Plunger) ... ..                 | 32          |
| Rear Chain (Swinging Arm) ... ..                   | 33          |
| Rear Chain (A10 Plunger) ... ..                    | 35          |
| <b>WHEELS</b> ... ..                               | 40          |
| Alignment (Solo) ... ..                            | 44          |
| Alignment (Sidecar) ... ..                         | 46          |
| Front Wheel Bearings ... ..                        | 40          |
| Front Wheel Removal ... ..                         | 40          |
| Front Wheel Replacement ... ..                     | 41          |
| Rear Wheel Bearings ... ..                         | 41          |
| Rear Wheel Removal (Swinging Arm) ...              | 44          |
| Rear Wheel Removal (A10 Plunger) ...               | 44          |

# TECHNICAL

## A7 Standard

|   |          |                             |
|---|----------|-----------------------------|
| Petrol tank capacity  | galls.   | 2 or 4                      |
| Oil tank capacity   | pints    | 5½                          |
| Gearbox capacity  | pints    | 1                           |
| Primary chain oilbath   | fl. oz.  | 8 (225 c.c.)                |
| Bore (m.m.)   |          | 66                          |
| Stroke (m.m.)   |          | 72.6                        |
| Capacity (c.c.)   |          | 497                         |
| Tappet clearances (cold) inlet and exhaust (inches)   |          | In. .010<br>Ex. .016        |
| Compression ratio   |          | 6.6 to 1                    |
| Piston ring gaps (inches)—(mean) see page 63:   |          |                             |
| Compression   |          | .013                        |
| Scraper   |          | .011                        |
| Valve timing—inlet  | (Opens)  | 30 E                        |
|   | (Closes) | 70 L                        |
| exhaust   | (Opens)  | 65 E                        |
|   | (Closes) | 25 L                        |
| Ignition timing (inches) (see page 24)—piston distance before T.D.C. with points just opening |          | 5/16                        |
| Spark plug  |          | L10S                        |
| Plug points gap (inches)  | maximum  | .020                        |
|   | minimum  | .018                        |
| Gear ratios—solo  | Top      | 5.28                        |
|   | Third    | 6.38                        |
|   | Second   | 9.28                        |
|   | First    | 13.62                       |
| With Sidecar  | Top      | —                           |
|   | Third    | —                           |
|   | Second   | —                           |
|   | First    | —                           |
| Tyre sizes (inches)   | Front    | 3.25-19 } Uni-              |
|   | Rear     | 3.50-19 } versal            |
| *Tyre pressures (p.s.i.)  |          | Solo                        |
|   | Front    | 17                          |
|   | Rear     | 19                          |
|   | Sidecar  | —                           |
| Chain sizes—Front   |          | 1/2 × .305"                 |
| Rear 5/8" × 3/8" (pitches) (solo)   |          | 98                          |
| (sidecar)   |          | —                           |
| Rear Brake Drum Chainwheel—   |          |                             |
| Solo  |          | 42 teeth                    |
| Sidecar   |          | —                           |
| Carburettor Main Jet  |          | —                           |
| Monobloc Carburettor Main Jet   |          | 210                         |
| Valves (Inlet and Exhaust)  |          | Stellite<br>Tipped<br>C & W |
| Air Cleaner   |          |                             |

\*NOTE.—The recommended inflation pressures are based on 'A' with plunger type rear suspension, with a rider's weight of 140 lb. swinging arm rear suspension (solo) add (8 lb.)

Front tyre: Add one lb. per sq. in. for every 28 lb. increase above 140 lb. If additional load is carried in the form of a pillion passenger or luggage, pressures increased in accordance with Dunlop Load and Pressure

NOTE: 1/4 pint =



# DATA

| A7<br>Shooting Star                | A10<br>Golden Flash<br>(fitted with Plunger<br>Rear Suspension) | A10<br>Golden Flash                | A10<br>Road Rocket                  |
|------------------------------------|---|------------------------------------|-------------------------------------|
| 2 or 4                             | 4½  | 2 or 4                             | 2 or 4                              |
| 5½                                 | 4½  | 5½                                 | 5½                                  |
| 1                                  | 1   | 1                                  | 1                                   |
| 8 (225 c.c.)                       | 4 (100 c.c.)  | 8 (225 c.c.)                       | 8 (225 c.c.)                        |
| 66                                 | 70  | 70                                 | 70                                  |
| 72.6                               | 84  | 84                                 | 84                                  |
| 497                                | 646   | 646                                | 646                                 |
| In. .008                           | In. .010  | In. .010                           | In. .008                            |
| Ex. .012                           | Ex. .016  | Ex. .016                           | Ex. .008                            |
| 7.25 to 1                          | 6.5 to 1  | 6.5 to 1                           | 8.0 to 1                            |
| .013                               | .013  | .013                               | .013                                |
| .011                               | .011  | .011                               | .011                                |
| 42 E                               | 30 E  | 30 E                               | 42 E                                |
| 62 L                               | 70 L  | 70 L                               | 62 L                                |
| 67 E                               | 65 E  | 65 E                               | 67 E                                |
| 37 L                               | 25 L  | 25 L                               | 37 L                                |
| 3/8                                | 11/32   | 11/32                              | 3/8                                 |
| NA.10                              | L10S  | L10S                               | NA.10                               |
| .020                               | .020  | .010                               | .020                                |
| .018                               | .018  | .018                               | .018                                |
| 5.28                               | 4.42  | 4.52                               | 4.52                                |
| 6.38                               | 5.36  | 5.47                               | 5.47                                |
| 9.28                               | 7.77  | 7.95                               | 7.95                                |
| 13.62                              | 11.41   | 11.67                              | 11.67                               |
| —                                  | 5.16  | —                                  | —                                   |
| —                                  | 6.26  | —                                  | —                                   |
| —                                  | 9.06  | —                                  | —                                   |
| —                                  | 13.3  | —                                  | —                                   |
| 3.25-19 } Uni-<br>3.50-19 } versal | 3.25-19 } Uni-<br>3.50-19 } versal                              | 3.25-19 } Uni-<br>3.50-19 } versal | 3.25-19 Ribbed<br>3.50-19 Universal |
| Solo                               | Sidecar   | Solo                               | Solo                                |
| 17                                 | 23  | 17                                 | 17                                  |
| 18                                 | 19  | 19                                 | 19                                  |
| —                                  | 18  | —                                  | —                                   |
| 1/2 x .305"                        | 3/8" Duplex   | 1/2 x .305"                        | 1/2 x .305"                         |
| 98                                 | 100   | 98                                 | 98                                  |
| —                                  | 104   | —                                  | —                                   |
| 42 teeth                           | 42 teeth  | 42 teeth                           | 42 teeth                            |
| —                                  | 49 teeth  | —                                  | —                                   |
| —                                  | 170   | —                                  | 340 (10 T.T.)                       |
| 270                                | —   | 240                                | —                                   |
| Stellite<br>Tipped<br>Vokes        | Stellite<br>Tipped<br>Vokes                                     | Stellite<br>Tipped<br>C & W        | Stellite Tipped<br>Ex Nimonic 80    |

models with swinging arm rear suspension, and A10 Golden Flash Golden Flash with passenger 140 lb. If the Golden Flash is fitted with If the rider is heavier increase tyre pressures as follows:

**Rear tyre** Add one lb. per sq. in. for every 14lb. increase above 140lb. the actual load bearing upon each tyre should be determined and the Schedule.

5 fl. oz. — 8 tablespoons.

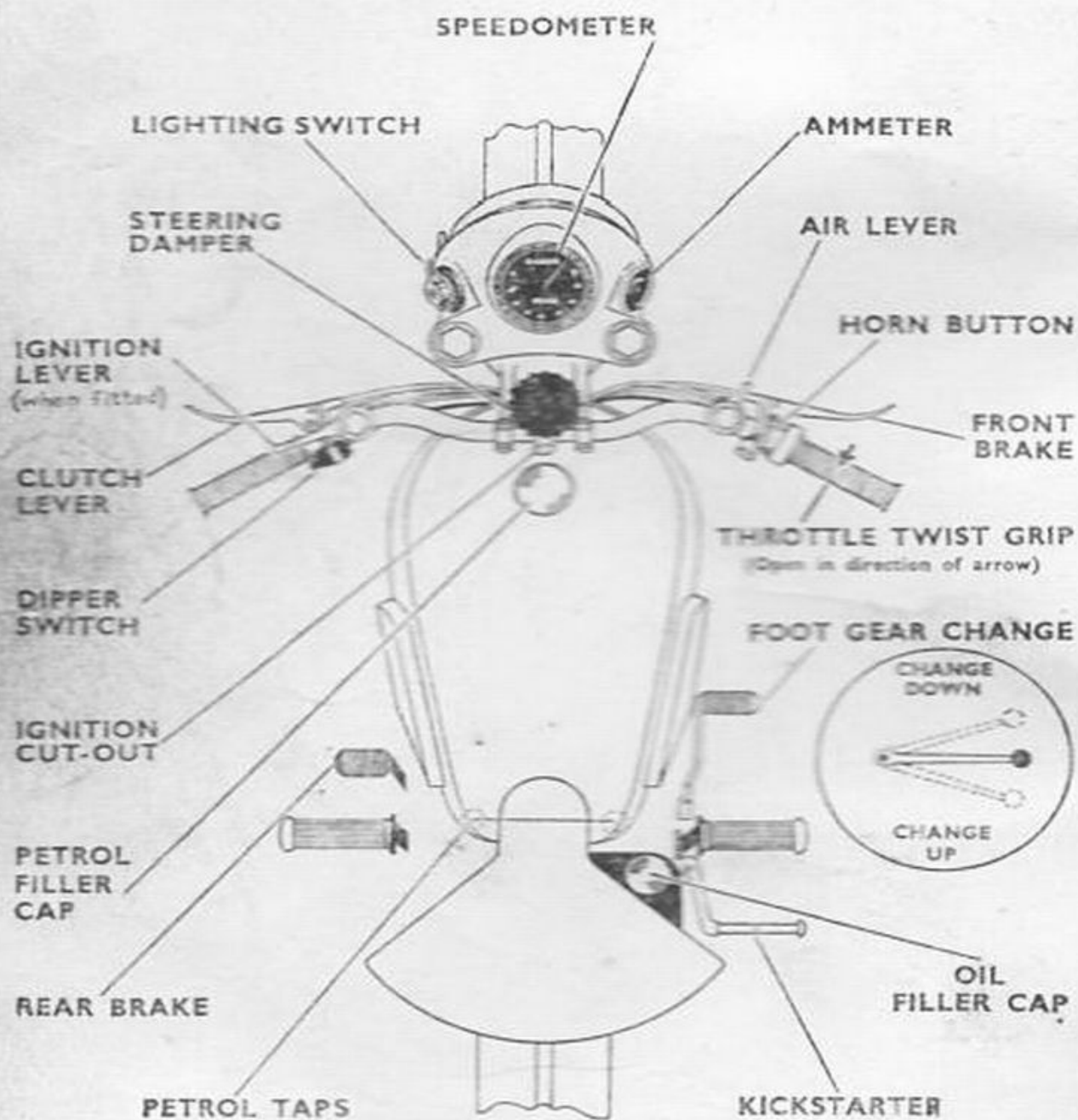

Fig. 1. The Controls.



## HANDLEBAR CONTROLS

### **Twist Grip Throttle.**

Controls the engine speed. To open the throttle (i.e., to increase the engine speed) turn the grip towards the rider. Full movement about one-quarter of a turn.

### **Front Brake.**

The lever is on the right bar, below the twist-grip throttle. Pull the lever towards the bar to apply the brake, and note that this lever operates the front brake only.

### **Carburettor Air Lever.**

On the right bar, and controls the supply of air to the carburettor, allowing the mixture of air and petrol to be varied as conditions require. Pull towards the rider to open (i.e., to increase the supply of air). Normal running position is fully open.

### **Horn.**

The control button is fitted on the back of the front brake lever.

### **Clutch Lever.**

Larger lever below the left bar. Pull towards the bar to declutch (i.e., to disengage the drive between the engine and the rear wheel). As the clutch lever is slowly released the drive is restored gradually. Always declutch when changing gear.

### **Dipper Switch.**

Fitted on the back of the clutch lever, and actuates the double filament bulb in the headlamp, giving either a normal or a dipped beam.

### **Ignition Cut-out.**

The control button is situated in the centre of the handlebars. Pressure on this for a second stops the engine, and it is useful for this purpose if the throttle is set for a reliable tick-over (see page 52).

### **Manual Ignition Control (A7 Shooting Star, A10 Road Rocket).**

Small lever on top of left bar, controls advance and retard of the spark produced by the magneto. Normal running position is fully advanced—lever moved forward into the closed position. For starting engine, the lever should be slightly opened.

## **FOOT CONTROLS**

### **Rear Brake Pedal.**

On the left hand side of the machine, and operates the rear brake only.

### **Gear Change Pedal.**

On the right hand side of the machine, and is used to effect the change from one gear to another. To engage first gear from the neutral position, the pedal is moved upwards. Second, third, and top gears are engaged by moving the pedal downwards. The pedal automatically returns to the central position, ready for the next gear change. When engaging a gear the pedal should be moved to its extreme limit, since the gear change is of the positive-stop type.

### **Kickstarter Pedal.**

Also on the right hand side of the machine, but is situated behind the gear change pedal. Depression of the kickstarter rotates the engine. See instructions on starting the engine. (See "Driving," page 10).

## **MISCELLANEOUS CONTROLS**

### **Petrol Taps.**

These are located under the rear end of the tank. To turn the petrol on, pull the button out and lock in position by turning anti-clockwise. To turn the petrol off, turn the button in a clockwise direction and push in. Both taps communicate with the main supply in the petrol tank, but if one tap only is used, a reserve is left in the tank which can only be fed to the carburetter when the second tap is turned on.



### **Steering Lock.**

Do not introduce oil into the keyhole as this may clog the wards and wash away the specially prepared lubricant inserted before assembly.

However, after considerable mileage or under adverse weather conditions, a few drops of thin machine oil may be applied to the periphery of the moving drum.

### **\*Lighting Switch.**

On the left of the headlamp cowl, controls the lighting of the lamps as indicated by the following markings:— H—Head, tail and instrument lamps. L—Pilot, tail and instrument lamps. OFF—Lights not in use but battery on charge.

### **\*Ammeter.**

On the right of the headlamp cowl. Enables the rider to see at a glance whether the battery is being charged or discharged.

### **Central Stand.**

This is of the spring-up type and so designed that when the machine is pushed forward off the stand, the latter springs upwards and is automatically retained clear of the road.

### **Steering Damper.**

Situated above the steering column at the centre of the handlebars, and should be used for high speed work only.

\*These components are centrally mounted in a panel on the top of the head lamp on Road Rocket models.

## **PREPARATION OF THE MACHINE FOR THE ROAD**

In order to obtain the maximum riding comfort from his machine, the owner should carry out three adjustments to suit his own requirements. The adjustments are:—Saddle height, footrest position, and handlebar position. The saddle height (not dual seat) can be altered at the spring pillars; it is only necessary to slacken the nuts, raise or lower the saddle as required and retighten the nuts.

## Footrests.

These are located on parallel serrated shafts pegged to the frame. To turn the footrest to a new position release the nut on the long bolt which holds both footrests, tap the bolt out sufficiently to allow the footrest arm to be knocked off its serrated shaft, and refit in the desired position.

## A10 G.F. plunger model.

On this model the footrests fit on to taper sleeves and after removal of the locking nut, the footrest may be moved to a suitable position. Take care to tighten the nuts securely, and note that the one on the left hand side has a **left-hand** thread. The handlebars pivot at the clamps in the centre of the bar, and if these are slackened the bar may be moved. **Make certain that the clamps are tight following the adjustment.**

Before taking the machine out for the first time, it is essential to examine the oil tank, to ensure that an adequate supply of oil is available. The tank has a capacity of  $5\frac{1}{2}$  pints, except for the Golden Flash Plunger model which has a capacity of  $4\frac{1}{2}$  pints. Use only high quality lubricants as recommended in the chart on page 42. Examine also the remainder of the lubrication points and verify the quantity of oil in the gearbox and the primary chain oil bath.

The petrol tank has a capacity of 4 gallons (2 gallons to order),  $4\frac{1}{2}$  gallons on A10 Golden Flash Plunger model. With a new machine it is worth while adding a small quantity of upper-cylinder lubricant, or, if this is difficult to obtain, add about an egg-cup full of engine oil to every two gallons of petrol.

## DRIVING

### To Start the Engine.

It will help in balancing the machine if you stand astride it when first attempting to start. Make sure that the gear control is in the neutral position, i.e., between first and second gear. Note that if the machine is in gear it will move forward when the kickstarter pedal is depressed.



If the engine is cold, first depress the carburetter tickler momentarily. (Retard the ignition slightly on Shooting Star and Road Rocket models). Close the air lever, open the twist-grip a small amount, and give the kickstarter pedal a vigorous kick downwards.

Note that while it is necessary to close the air lever when starting from cold, this may not be necessary when the engine is warm, and should certainly not be so if a restart is made after a short wait only. On some occasions, such as when the engine is not fully warmed up, or when it has cooled down a little during a temporary halt, for instance, it may require the air lever to be partly closed for starting, and the rider is advised to study this point.

During normal running the air lever should always be kept fully open, and the ignition lever advanced as far as possible on the Shooting Star and Road Rocket models, although a slight gain in power at low speeds on hills may sometimes be obtained if levers are both eased back a very small amount.

#### **To engage First Gear.**

Depress the clutch lever (i.e., declutch), and move the gear change pedal *upwards* to its limit. If difficulty is experienced when engaging first gear when stationary, rock the machine backwards and forwards maintaining slight pressure on the gear change pedal until the gear is felt to engage.

#### **To Move Off.**

Open the throttle slightly and gently release the clutch lever. As the clutch engages, open the throttle a little further, and when the clutch is fully engaged the machine can be accelerated to a suitable road speed, ready for changing into the next gear.

#### **To Change Gear (Up).**

Close the throttle, disengage the clutch and press the gear change pedal downwards to its limit, all these operations being performed simultaneously. Engage the clutch and re-open the throttle together, immediately after changing. *Note.*—Violent pressure on the gear change pedal is neither necessary nor desirable.

### To Change Gear (Down).

Open the throttle slightly, disengage the clutch and raise the gear change pedal upwards to its limit, all these operations being performed simultaneously. Re-engage the clutch immediately.

*Note.*—The above movements are quite easy to perform and a little practice will ensure a rapid and quiet gear change. When changing gear, either up or down, it is preferable—after moving the pedal—to hold it momentarily in position with the foot until after the clutch lever has been released, when the gears will be felt to engage.

Do not use an excessive opening of the throttle when starting, and do not allow the engine to race when stationary. Use the throttle control to govern the speed of the machine, e.g., when descending a steep hill, if a lower gear is engaged and the throttle closed, the engine will control the speed of descent. On very greasy roads the use of the engine as a brake is to be advocated, particularly in conjunction with a change to a lower gear. It is never advisable, except in cases of emergency, either to accelerate or to brake fiercely; when the roads are greasy both are extremely dangerous.

### 'RUNNING-IN' A NEW MOTOR CYCLE

The rider who has just purchased a new machine will do well to remember that all the internal parts are just as new as the enamel and plating which can be seen, and that they must be well 'run-in' before the engine can be given any really hard work.

The 'running-in' process is the most important period in the life of the engine, and the handling it receives during the first 1,000 to 1,500 miles will determine the service it will provide in return.

It is advisable not to exceed half throttle in any gear. If excessive speeds are used there is risk of piston seizure and other troubles, and in any event until the machine has been 'run-in' it cannot be

expected to give its best performance. In particular, avoid rapid acceleration, especially when the engine is not under load, and do not allow the engine to 'labour' on hills in a high gear when a change to a lower gear would ease the load on the engine.

Do not let the oil level in the tank get too low, as economy in oil may prove very expensive at a later date. Running consistently with the level too low may cause the oil to become unduly hot. It must be remembered that the oil cools as well as lubricates, and a new engine tends to run a little hotter than one that is well 'run-in.' After the first 250 miles, drain and refill the oil tank with fresh oil and clean the filter (Figs. 3 and 4, pages 16 and 17). Repeat this process after 1,000 miles, and thereafter every 2,000 miles. The correct grades of oil are given in the lubrication chart on page 42. The gearbox should be drained after the first 500 miles, and thereafter every 2,000 miles.

### THE LUBRICATION SYSTEM

The engine lubrication system (see Fig. 2) is of the dry sump type operated by a double gear pump, situated in the bottom of the timing case. All oilways are internal except for the supply and return pipes from the tank and the oil feed to the valve rockers. The oil flows from the tank—through a filter in the tank—to the supply portion of the pump, which delivers it past an automatic anti-syphon ball-valve to the timing side main bearing and thence to the hollow crankshaft and the big-end bearings, whilst a further internal oilway supplies oil via a pressure control valve to the timing gears and camshaft trough.

After lubricating these parts and circulating through the engine in the form of mist, the oil drains down through a filter in the bottom of the crankcase, from which it is drawn by the return portion of the pump and delivered via another anti-syphon ball-valve through the return pipe to the tank.

There is also an oil supply to the rocker box which is taken from the pump return pipe, and is fed through an external pipe at the rear of the engine to unions at the ends of the rocker spindles.



To check the flow of oil in the lubricating system, remove the tank filler cap whilst the engine is running. Oil should be seen issuing from the return pipe from the crankcase. The tank and crankcase should be drained periodically, and replenished with clean oil (see Periodical Maintenance, page 17).

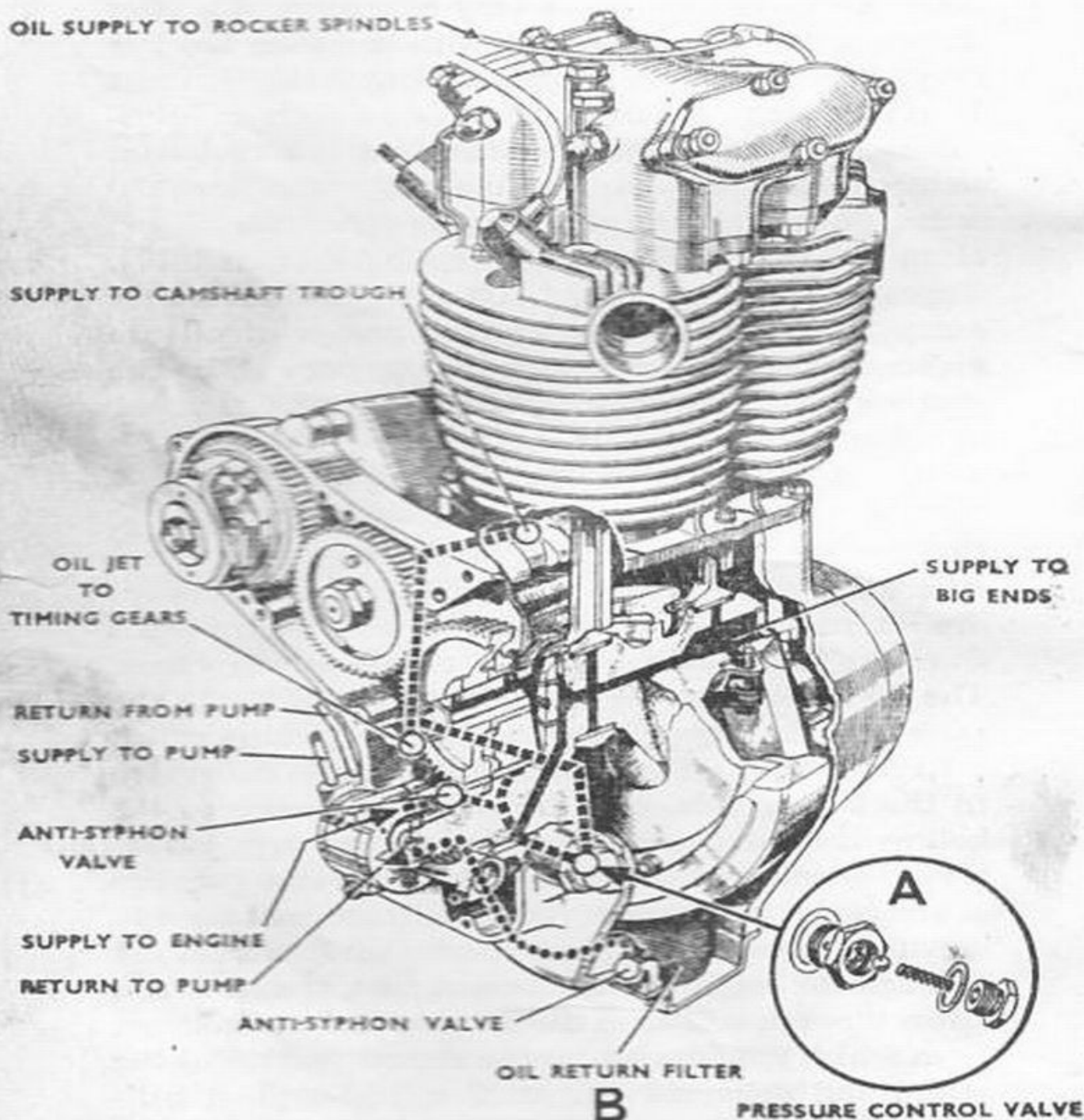

Fig. 2. Engine Lubrication.

### Ball Valves.

A by-pass valve is interposed between the delivery

side of the pump and the big-end bearings. This is pre-set to control the pressure in the supply system, and it should be examined periodically—say every 1,000 miles—to ensure that it is operating freely and not impeded by the presence of even tiny particles of foreign matter. The construction of this valve is shewn in the exploded view A, Fig. 2, and if it is dismantled, the parts should be thoroughly rinsed in petrol before reassembly.

Note that both hexagons must be screwed right home and made really tight.

If the anti-syphon ball valve in the crankcase sump should adhere to its seating, there will not be any return flow of oil to the tank. To correct this, remove the cover plate—insert a piece of wire into the valve orifice, and lift the ball off its seating to free it.

#### **Tank Pressure Release.**

The oil tank is fitted with a racing type breather tower. It is necessary to keep the short length of tube clear which projects horizontally from it. (See Fig. 3).

#### **Tank Pressure Release. (Plunger Model).**

Any restriction in the pressure release pipe in the oil tank will cause an increase in pressure inside it and will result in leakage of oil at the filler cap. This can be rectified by inserting a length of flexible wire into the pipe at its lower end (just in front of the rear mudguard) and pushing the wire right up the pipe, thus clearing any obstruction.

#### **Filters.**

It is not necessary to unscrew the oil pipe union, the oil tank filter being attached to the large chromed drain plug screwed in the side of the tank. The supply pipe which will be seen when the drain plug is removed, draws its oil through the filter.

**Note: The lower oil tank union is the oil feed to the engine and the feed pipe should be connected to the lower union on the crankcase.**

#### **Filters. (A10 G.F., Plunger Model).**

To remove the oil tank filter (Fig. 4) for cleaning,

unscrew the oil pipe union at the bottom of the tank, when the filter will come out with the plug.

**All Models.**

The crankcase filter *B* (Fig. 2), can be withdrawn after removing the cover plate.

The filters should be thoroughly washed in petrol and carefully dried before replacement.

**Oil.**

The correct grades of oil are given in the chart on page 42.

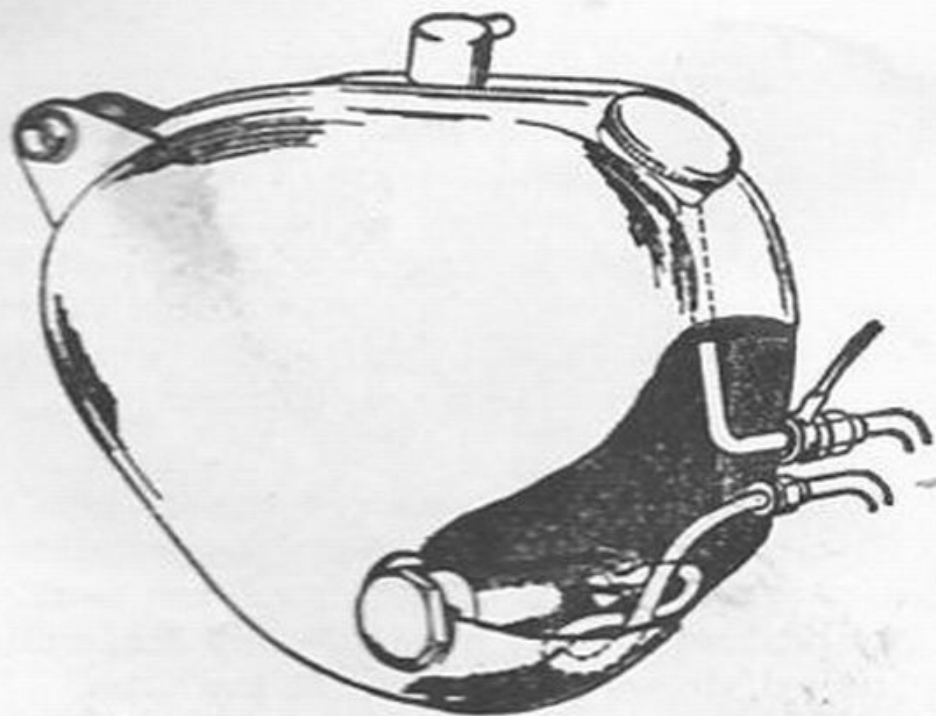

Fig. 3. The Oil Supply (Swinging Arm models).



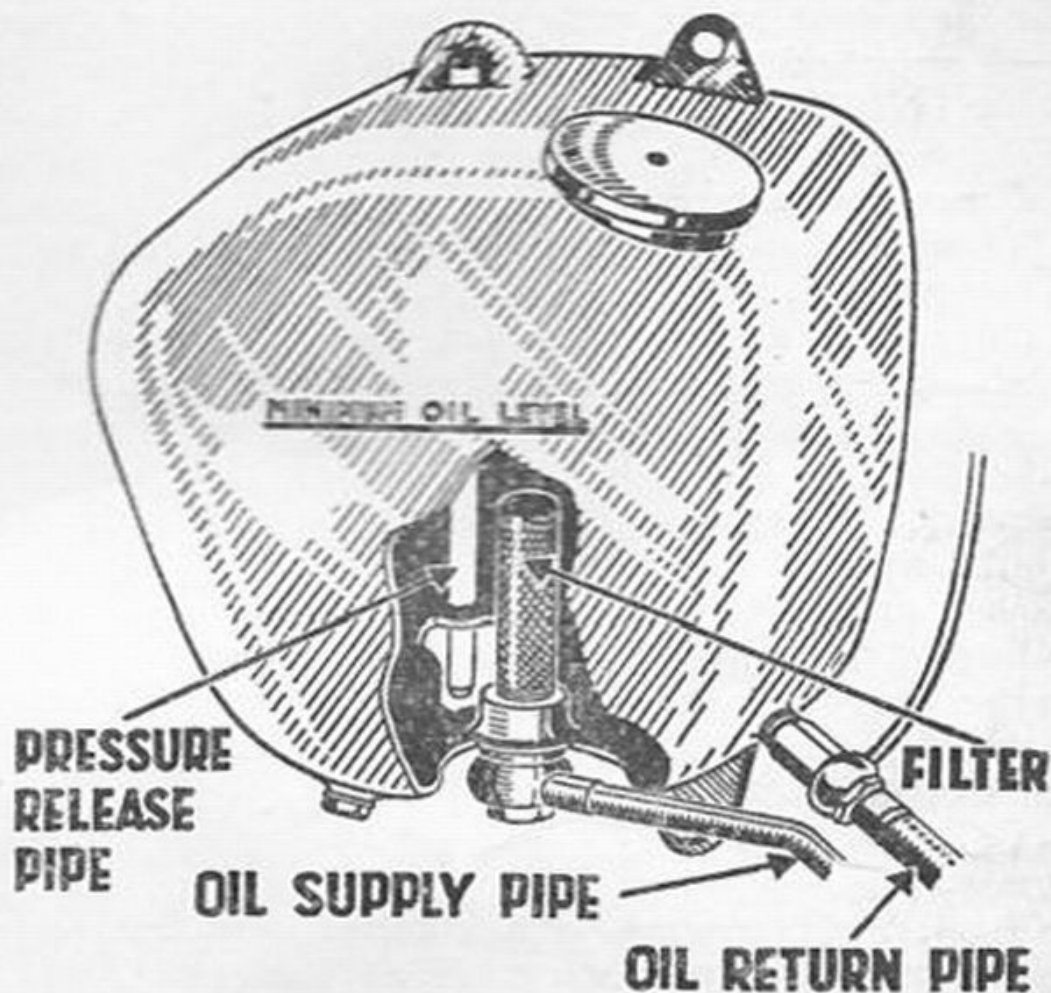

Fig. 4. The Oil Supply (A10 G.F. Plunger model).

## PERIODICAL MAINTENANCE

### WEEKLY

#### Cleaning.

Obviously regular and thorough cleaning will keep your machine looking smart and will help to retain both its new appearance and value. But it helps also to lengthen its life and maintain efficiency if the cleaning process is carried out correctly.

Take special care to prevent dust and grit from working into such parts as hubs, carburetter, magneto, dynamo, brakes and gearbox.

To rub dry and caked mud from the frame, tank and mudguards means that the enamel on these parts will be subjected to an abrasive action which will quickly destroy the polish. Soak the mud first,

and then float it off with copious supplies of clean water supplied either with a hose or a sponge. If a hose is used, take care not to direct the stream of water directly on to the hub bearings, magneto, dynamo and carburetter.

When all dirt is removed, dry and polish off with a clean duster.

The engine and gearbox are best cleaned with a brush and paraffin, and then dried off with clean rag.

### **Oil Tank.**

Inspect the level of oil at least once a week. It should never be allowed to fall below the level marked on the outside of tank. When topping-up, do not fill the tank completely; leave about one-inch margin between the oil and top of tank. If this precaution is not observed, it is possible that oil will seep from the filler cap.

### **Tyres.**

Check the pressures with a gauge, and inflate to correct pressure if necessary. (See 'Technical Data,' page 4).

Examine carefully for cuts and remove any flints or metallic scraps which may have become embedded in the cover.

### **Gearbox.**

Examine oil level and top-up if necessary. The oil is added through the filler cap aperture on the right hand side of the box. (See page 20).

**Brake Pedal  
Control Joints  
Exposed Cables**

} A few drops of oil are required to ensure smooth operation.

**Steering Head  
Saddle Nose Bolt  
(except Dual Seat)  
Rear S/Car Connection  
S/Car Spring Shackles  
Rear Suspension**

} A few strokes of the grease gun will be sufficient to ensure satisfactory lubrication.

## **Battery.**

Top-up as often as necessary to maintain the level of electrolyte one-quarter inch above the top of the plates. Always use distilled water when topping-up. (See page 70).

To gain access to the battery on machines fitted with swinging rear arm suspension, remove the two bolts under the dual seat at the rear. The seat can then be drawn backwards out of its front locating grooves and clear of the machine revealing the battery. Remove the two small bolts holding the battery strap over the battery and unscrew the battery terminals. The battery can then be lifted out.

## **EVERY 1,000 MILES**

### **Hubs.**

Inject grease through the nipple in the centre of the hub. Do not over-lubricate as grease may be forced on to the brake linings and cause ineffective brakes. Three or four strokes of the grease gun should be ample. **Do not lubricate with oil.**

### **Steering Head.**

Lift the machine and place a box under the crankcase so that front wheel is clear of the ground. Test for play in the steering head by trying up-and-down movement. Check also that steering is free. If necessary, adjust as explained on page 48.

### **Brake Cam Spindles.**

Front: (Nipple) One stroke of grease gun.

Rear: A few drops of oil is all that is required.

### **By-Pass Valve.**

Remove and examine for cleanliness, as described on page 14, and illustrated at *A* (Fig. 2).

### **Tappet Adjustment.**

The valve clearances must be checked when the engine is cold. The correct method of checking and adjusting is explained on page 22.

### **Clutch.**

A few strokes of the grease gun at *F* (Fig. 13) *D* (Fig. 14) A10 G.F. Plunger model will ensure free movement of the control arm.



There must be a small amount of play in the clutch control either at the control arm above the gearbox or at the handlebar lever. If excessive, difficulty will be experienced in changing gear, since the clutch will not dis-engage completely. This can be adjusted as explained on page 36.

### **Chains.**

Check the primary chain tension, which should not exceed a total up-and-down movement of half an inch. Remove the chaincase filler cap *A* (Fig 6) for this purpose.

The rear chain movement should not exceed half an inch with the wheel set at the lowest point in the suspension unit.

If the play exceeds the above figure, adjust as described on pages 32 to 35.

### **Sparking Plugs.**

Examine and clean and adjust points if necessary. (See page 29).

## **EVERY 2,000 MILES**

### **Oil Tank.**

Drain out the old oil (preferably after a run while the engine is still warm), wash out with flushing oil or thin machine oil—not paraffin or petrol—and refill with new oil. The correct grades of oil are given in the lubrication chart on page 42.

### **Filters.**

There are two filters which require attention:

1. The oil tank filter, page 16 (Fig. 3), page 17 (Fig. 4).
2. The crankcase filter *B*. (Fig 2), which can be withdrawn after removing the cover plate.

Wash the filters thoroughly in petrol and dry them carefully before replacing.

### **Gearbox.**

Remove the inspection cap (Fig. 13) (Fig. 14 A10 G.F. Plunger model) and the level plug at the rear of the gearbox. Unscrew the drain plug underneath

the box and drain out the old oil, preferably after a run while the oil is still warm. Wash out the gear-box with flushing oil and re-fill with new oil through the inspection cap until it issues from the level plug hole. Replace the level plug and the inspection cap. The correct grades of oil are given in the lubrication chart on page 42.

#### Automatic Advance Unit. (A7 Standard and A10 Golden Flash only).

Remove the timing cover and examine the advance and retard mechanism attached to the magneto gear to make sure that the governor weights move freely. (See page 29).

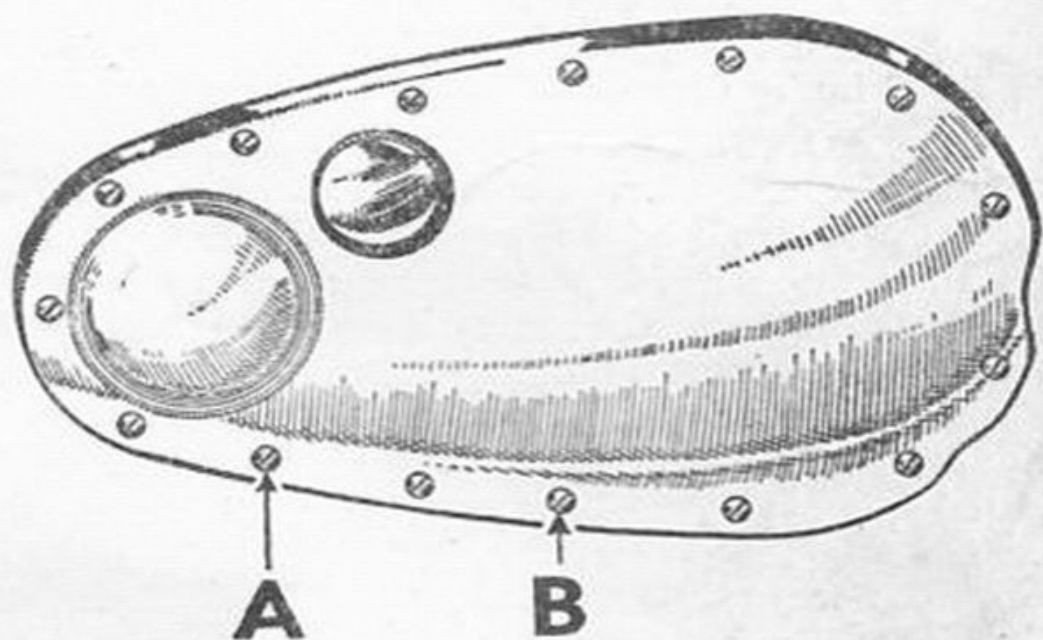

Fig. 5. Primary Chaincase (Swinging Arm models).

#### Primary Chain Oilbath.

On machines fitted with swinging arm suspension, two cover fixing screws are painted red. (See Fig. 5). These are marked *A* and *B*, being the level indicator and drain screws respectively. The oil level should be determined with the machine on level ground off the stand. Do not fill above this level or clutch slip may occur. Approx. capacity 8 fl. oz. (225 c.c.).

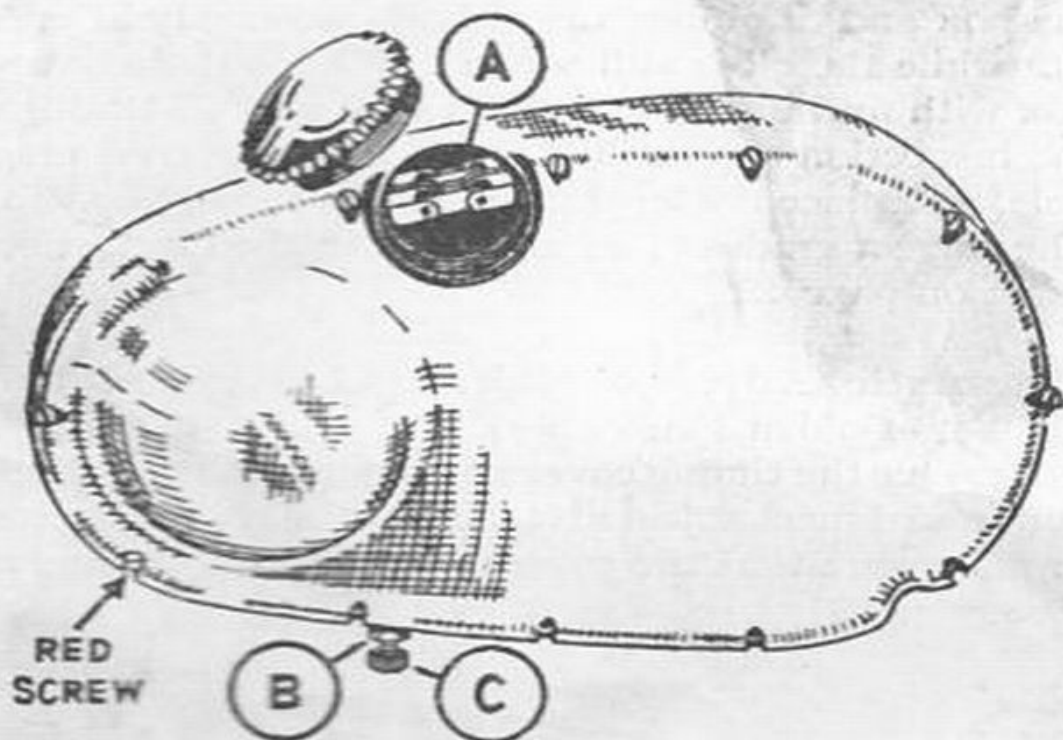

Fig. 6. Primary Chaincase (A10 G.F. Plunger model)  
Primary Chain Oilbath. (A10 G.F. Plunger model).

Removal of one of the cover fixing screws, Fig. 6 (identified by its red painted head) exposes a hole which determines the level of oil in the case. Remove the screw and top-up with engine oil if necessary, through the filler orifice *A*. The machine should be on level ground when the check is being carried out, and the approximate capacity of the case is 4 fl. oz. (100 c.c.).

#### Central Stand Fulcrum.

A few strokes of the grease gun will be sufficient.

#### Dynamo

#### Magneto

#### Contact Breaker

} See electrical section,  
pages 71, 72.

#### Chains.

Remove the rear chain, which should be cleaned and lubricated as indicated on page 39.

### HOW TO CARRY OUT THE VARIOUS ADJUSTMENTS

#### I. THE ENGINE

#### Valve Clearances.

Checking and adjustments of the valve clearances must always be carried out with a cold engine, when



the amount of clearance for all valves should be .010" in., .016" ex., except the Shooting Star, which is inlet .008 in., exhaust .012 in., Road Rocket .008 in. both valves. Examine or remove, in the following order:

*The tappet inspection covers (A, Fig. 7).* A special spanner is provided in the kit for unscrewing the four nuts.

*The two sparking plugs.* This enables the engine to be turned easily by hand, via the kick-starter.

*Rotate the engine until one inlet valve is fully open and check the clearance of the other inlet valve.* Use the 'feeler' gauge provided in the toolkit. This method ensures that the valve, whose clearance is being checked, is fully closed. The gap should be such that the gauge will only just enter.

*Rotate the engine again and adopt similar measures for the inlet valve on the opposite side of the engine.*

*Repeat the procedure for the two exhaust valves.*

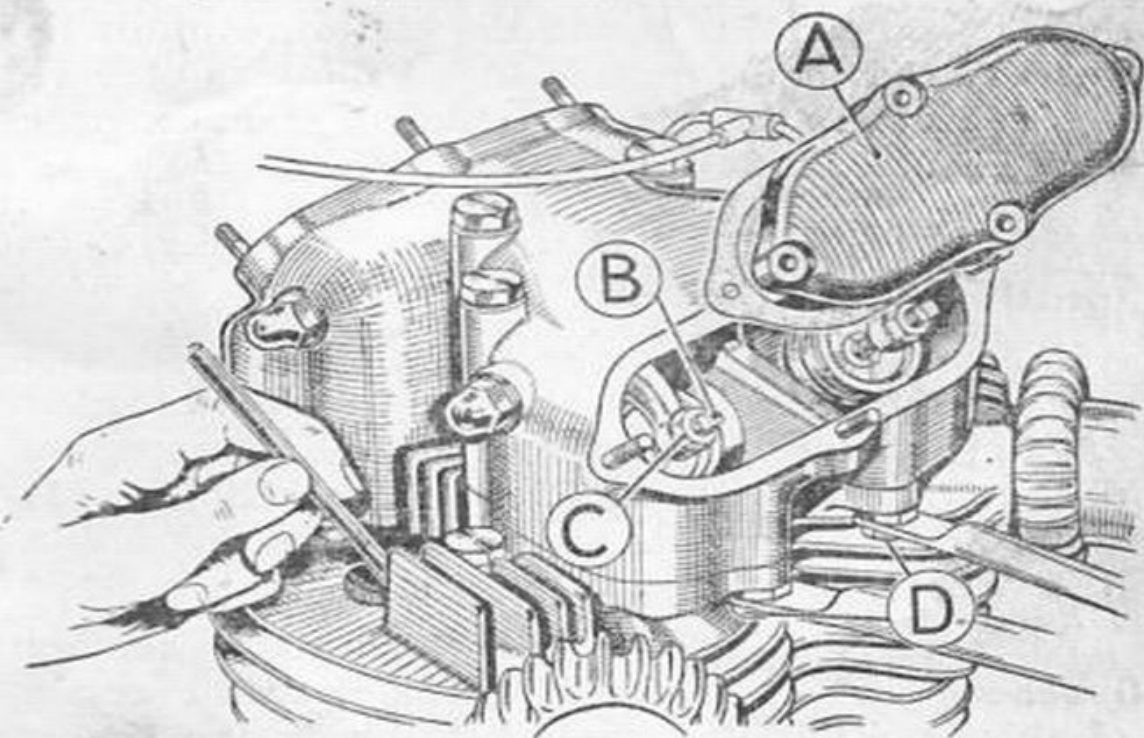

Fig. 7. Tappet Adjustment and Ignition Setting

If it is found that adjustment is required, set each valve in turn in the closed position as described above, and proceed as follows:

*Apply a spanner to the flats on the adjusting screw at B (Fig. 7). Hold it stationary, in order to assist in the operation of releasing the locknut.*

*Slacken locknut C with a tappet spanner. The operation should be carried out simultaneously with the previous one.*

*Hold nut C stationary and adjust screw B. The latter should be moved up or down until the space between the valve and end of the screw is only just sufficient for the feeler gauge to enter.*

*Retain the screw B in this position, and tighten locknut C securely against the rocker arm.*

*Check the clearance. This is to make certain it has not altered while tightening the nut.*

*Replace the sparking plugs and the inspection covers taking care not to damage their gaskets.*

When the engine warms up to its normal running temperature the valve clearances tend to increase slightly and for this reason the clearances must be set with the engine quite cold. Failure to observe this instruction may lead to difficult starting, poor performance, burnt valves, etc.

### **Ignition Timing.**

The standard ignition setting for 'A' models is given in the Technical Data, page 4. When models A7 and A10 are fitted with the high compression piston (7.25 to 1) the ignition setting is 3/8 in. It is not advisable to interfere with the setting unless it is strongly suspected to be at fault.

After any attention to the magneto contact breaker points (see page 72 of the electrical section of this book) it is advisable to check the timing since opening the points advances, and closing them retards the timing.

The ignition timing can be re-set, if the various components are removed, or examined in the following sequence:

*The two sparking plugs.* This enables the engine to be turned easily by hand, via the kick-starter.

*Examine the fully open gap between the contact breaker points.* Adjust if necessary, to between .010 in. and .012 in.

*The tappet inspection covers A (Fig. 7).* A special spanner is provided in the kit for unscrewing the four nuts.

*The timing cover.* This is held on by 12 screws of varying lengths. Note these for replacement afterwards.

*Release the magneto pinion from its shaft.* The central nut which locks the pinion on to the shaft, also acts as an extractor (except Shooting Star and Road Rocket). Unscrew the nut in an anti-clockwise direction, when it will eventually become tight to turn. Now remove the 'Cee' washer. A sharp blow on the end of the spanner (to unscrew the nut in the same direction) will finally free the pinion. Note that the automatic advance mechanism is in unit construction with the pinion and is detached with it. On Shooting Star and Road Rocket the magneto pinion is removed by releasing the central nut and using an extractor. Alternatively a lever can be used, slackening the central nut only and giving the shaft a sharp tap with a soft hammer to free the pinion from its taper.

*Rotate the engine in a forward direction until the right hand side piston is at the top of its compression stroke.* Check its position by means of a rod inserted through the sparking plug hole and resting on the piston head (see Fig. 7); also make sure that both inlet and exhaust valves are closed, i.e., that the tappet clearance can be felt. By this means, the piston will be at its correct top dead centre for timing purposes.

*Turn the engine in the reverse direction until this piston has descended the correct amount (see above) from the top of its stroke.* This is best accomplished by engaging top gear and revolving the rear wheel backwards by hand. A little care is necessary to



ensure that the dimension given is rigidly maintained.

*Shooting Star and Road Rocket.* Set the ignition lever forward in the fully-advanced position.

*A7 Standard, A10 Golden Flash.* Set the automatic advance unit in the fully-advanced position. If the central bridge plate is turned in an anti-clockwise direction the governor bob-weights can be seen to move outwards against the resistance of the springs. This is the fully-advanced position and the weights should be wedged as shown at *B*, Fig. 8, for timing purposes.

*Re-fit the magneto pinion loosely on its shaft.* This is so that the shaft can be moved independently of the pinion as required in paragraph 11.

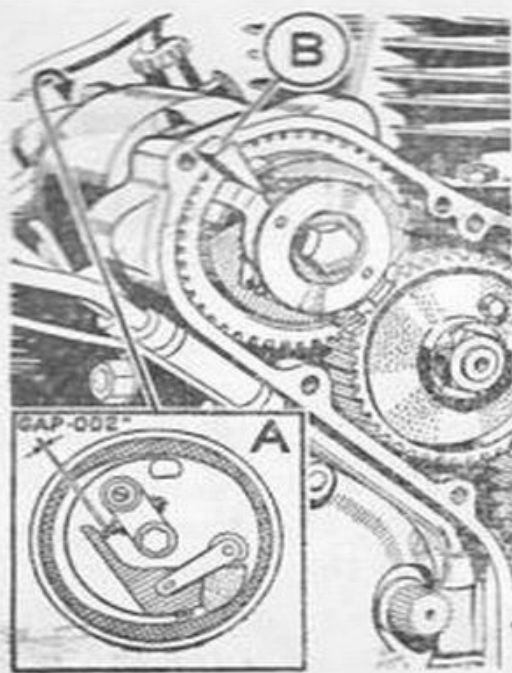

Fig. 8. Automatic Advance. (A7 Standard and A10 Golden Flash).

*Rotate the contact breaker at the opposite end of magneto, in its normal direction of rotation until the contact points are just open (not more than .002 in.), see A, Fig. 8.*

*Tap the magneto pinion home on to its taper.*

*Carefully check the ignition setting. If correct, tighten the central nut.*

*(A7 Standard and A10 Golden Flash only).*

*Remove the wedge from governor bob weight.*

Replace the timing cover (renewing the paper gasket if necessary to ensure an oil-tight joint), together with the tappet inspection covers and sparking plugs.

It cannot be too strongly emphasized that the ignition timing must be correctly set for satisfactory engine performance, and also that any temptation to improve upon the maker's setting should be avoided, as this setting has been found best after careful trial and experiment. The fact that A7 Standard and A10 Golden Flash engines are fitted with automatic ignition advance makes it all the more necessary that the above timing instructions should be faithfully carried out.

### Valve Timing.

Under normal running conditions the valve timing cannot become disturbed, and it is inadvisable to dismantle the timing gear train unless absolutely essential. Should it be necessary, however, to check the timing, the following procedure should be observed, components being removed in the following order:

*Timing Cover.* Note the positions of the fixing screws, which have varying lengths.

*Dynamo driving chain.* This is of the endless type (i.e., there is no connecting link), so that the chain and the large sprocket must be taken off together. The sprocket fits on to a tapered shaft without a key, and after removing the nut and locking washer, the use of a suitable extractor is advisable to avoid possible damage to the cover. Alternatively, apply a spanner to the dynamo sprocket nut and give it a sharp blow in a clockwise direction, with the chain in position. This should free the large sprocket. Once the large sprocket is withdrawn from its spindle, the chain may be lifted off the small sprocket, leaving the latter still in position on the dynamo spindle.

*Dynamo strap.* This should be slackened to enable the dynamo to be revolved by hand to a suitable position, so that its sprocket can pass

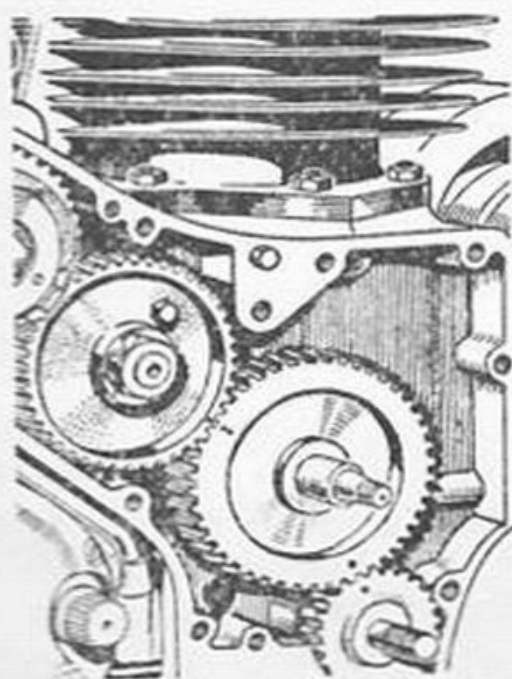

Fig. 9. Valve Timing Marks.

through the aperture in the inner timing cover, when the latter is removed.

*The inner timing cover.* Four screws hold this in position and they are deeply recessed. The breather sleeve will probably remain in the cover, leaving the cork washer adhering to the camshaft gear.

*Examine the timing gears.* Verify that their

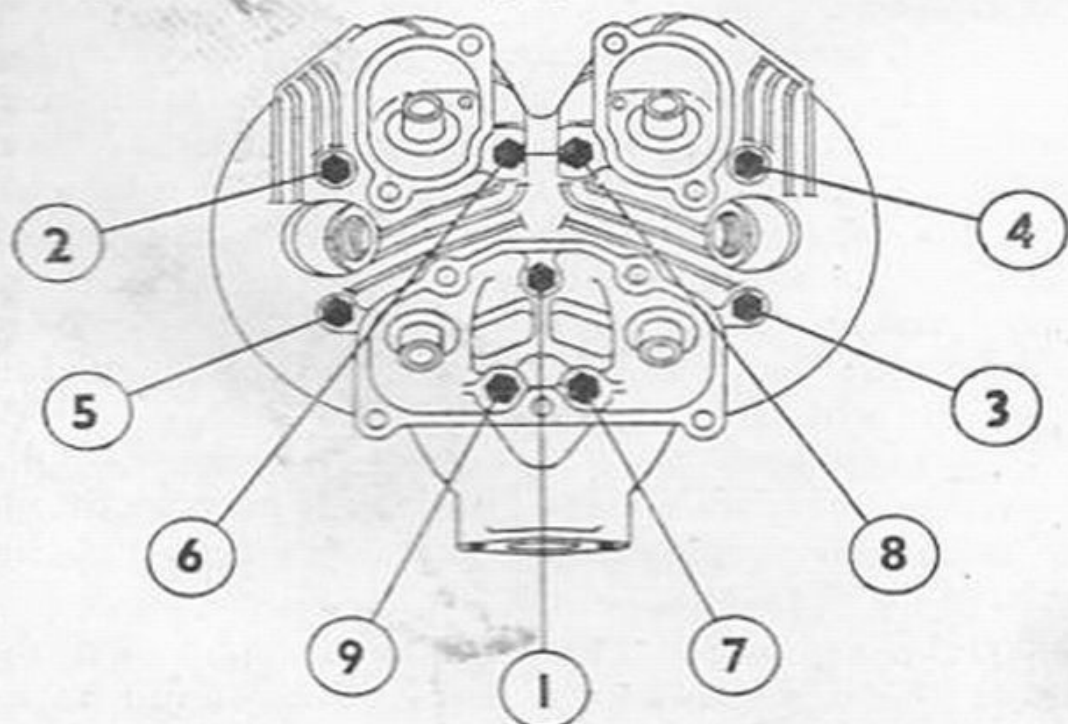

Fig. 10. Cylinder Head Bolts.



markings correspond with those shown in Fig. 9. It may be necessary to revolve the engine several times before the marks appear in their correct positions.

During reassembly, make sure that the breather cork washer is intact (replacing if necessary) and that the driving peg in the camshaft gear engages with the hole in the breather sleeve. Remember to bend the locking washer into position on the large dynamo chain sprocket after tightening the nut. Before tightening the dynamo strap, press the dynamo firmly against the back of the timing case to ensure an oil tight joint by trapping the cork seal. Finally, fit new paper washers between the cover joint faces.

### **Cylinder Head.**

After the machine has covered its first 250 miles when new or after decarbonising, check the tightness of the cylinder head bolts. This is because the gasket tends to settle down after the initial clamping. To ensure even distribution of pressure with consequent freedom from distortion, tighten the bolts in rotation as shown in Fig. 10.

**Automatic Advance Unit.** (Fig. 8; A7 Standard and A10 Golden Flash only).

This is contained within the timing case and is in unit construction with the magneto pinion. Attention to the unit can be given after removal of the timing cover, which is retained by twelve screws of varying lengths. Note these for replacement purposes.

Examine the automatic advance unit making sure that the governor bob-weights move freely and that if the unit is turned by hand to the advance position (weights fully extended outwards) and released, the springs withdraw the weights to the inner position (retarded).

If necessary lubricate thoroughly with engine oil.

### **Sparking Plugs.**

The sparking plug is of great importance in satisfactory engine performance, and every care should

be taken to fit the correct type when replacements are necessary. There is little to be gained by experimenting with different plugs as the make and type fitted by us as official factory equipment is best suited to the requirements of the motor. This is Champion Type No. L.10S. (NA.10 for Shooting Star and Road Rocket), as illustrated in Fig. 11.

Remove each sparking plug every 1,000 miles (1,500 km.) or so for inspection. If the carburation system is in correct adjustment the sparking plug points should remain clean almost indefinitely. An over-rich mixture from the carburetter will, however, cause the formation of a sooty deposit on the points and, later, on the plug end face (as upper view, Fig. 11). If therefore such a deposit is found, clean it off carefully and check your carburetter.

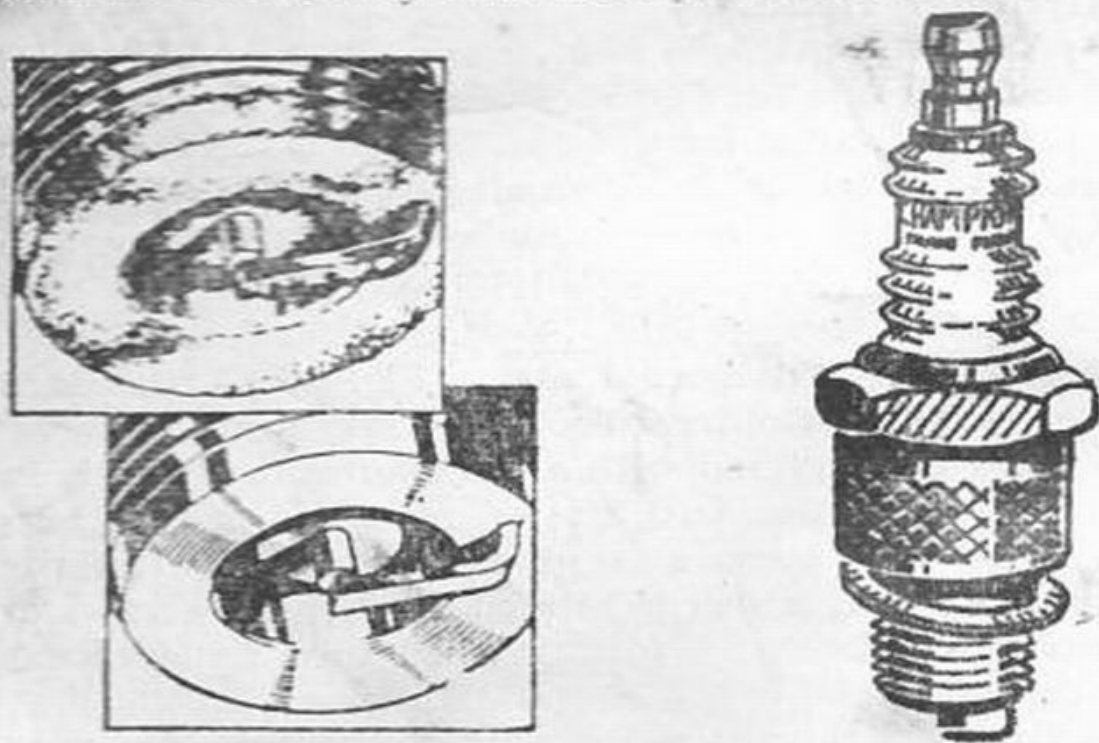

Fig. 11. The Sparking Plug.

The continued use of leaded fuel may also eventually produce a deposit on the plug—this time of a greyish colour.

A light deposit due to any of these causes can easily be cleaned off, but if it is allowed to accumulate, particularly inside the body, the plug may spark internally with an adverse effect on engine

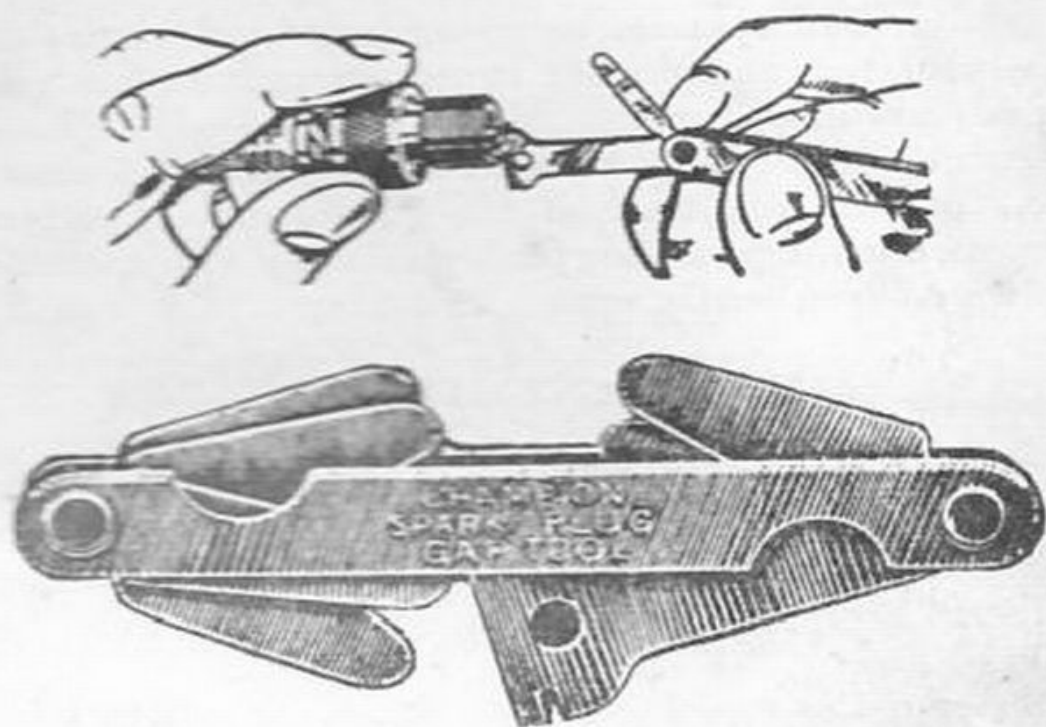

Fig. 12. Setting the Plug Points.

performance—if, indeed, it does not stop the engine altogether. The plugs should be cleaned and tested at regular intervals, and it is suggested that this service be performed at your garage on a special 'Air Blast' service unit. If eventually the cleaning process fails to restore the plug to its original condition of efficiency, it should be replaced by a new one.

When inspecting a plug, also check the gap between the points. This should be .018-.020 in. (.45-.50 m.m.) and adjustment should be made by bending the side wire (see Fig. 12). **Never attempt to remove the central electrode**, and it is always advisable to use the special plug gap tool illustrated obtainable at 2/- from any Champion Plug stockist or from the Champion Sparking Plug Co. Ltd., Feltham, Middlesex. Feeler gauges are attached to verify correct gap.

When refitting a plug, make sure that the copper washer is not defective in any way. If it has become worn and flattened, fit a new one to ensure obtaining a gas-tight joint.

Screw the plug down by hand as far as possible, then use a spanner for tightening only. Always use



a tubular box spanner to avoid possible fracture of the insulator, and do not in any circumstances use an adjustable spanner.

Paint splashes, accumulation of grime and dust, etc., on the top half of the insulator are often responsible for poor plug performance. Plugs should be wiped frequently with a clean rag.

## II. TRANSMISSION

### Primary Chain (with Swinging Arm models).

The chain is adjusted by pivoting the actual gearbox backwards or forwards about its lower fixing bolt *A*, Fig. 13. This operation is carried out as follows:

Slacken the two large nuts *A* and *B* which lock the gearbox in position. One of these nuts is immediately under, and the other vertically above the gearbox. The latter *B* also holds the adjuster in position.

Release the locknut *C* on the adjuster and screw the actual adjuster nut *D* in a downwards direction, this will draw the gearbox backwards, tightening the chain. There should not be less than a total of half-an-inch up and down movement in the centre at the tightest point of the chain.

Finally, retighten the adjuster locknut *C* and the two large gearbox fixing nuts *A* and *B*. Note that after tightening this chain the rear chain will need checking.

### Primary Chain. (A10 G.F. Plunger model).

This is of the duplex type with its sprocket centre fixed and adjustment is made by means of a special tensioner as detailed below:

*Remove the filler cap A (Fig. 6).* Through the orifice the chain can be seen and its tension checked, with the fingers. It is not necessary to remove the outer half of the case.

*Slacken locknut B (Fig. 6 or Fig. 15).*

*Screw adjuster C upwards (into the case) to tighten the chain.*

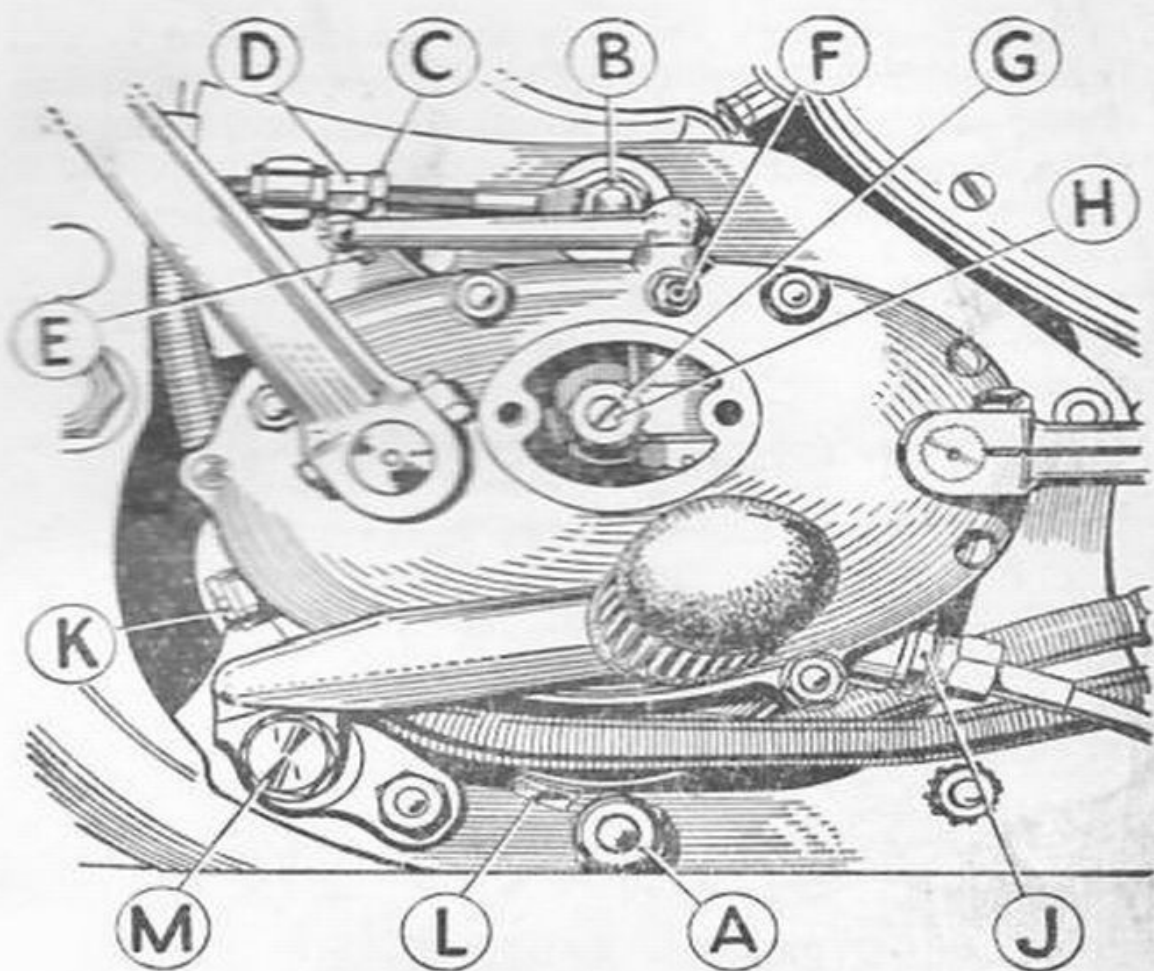

Fig. 13. Clutch and Front Chain Adjustment.  
(Swinging Arm models only).

*Check the chain tension.* This should be such that there is a total up and down movement of *not less than half-an-inch.*

*To reduce the chain tension, screw the adjuster C downwards and apply pressure on the kickstarter pedal.* By this means, the tensioning 'slipper' will move down and slacken the chain. This is illustrated in Fig. 15.

Tighten locknut *B* and replace the filler cap.

### Rear Chain.

*Set the machine on its stand.* The rear wheel must be in its lowest position in the suspension unit, for the purposes of this adjustment. (See Fig. 16).

*The rear brake adjuster.* This must be slackened off, otherwise the brake rod may prevent full movement of the wheel.

Insert a tommy bar into the spindle head *B* and unscrew it a little (right-hand thread), until the inner sleeve nut *A* can be slackeden sufficiently to allow movement of the rear wheel.

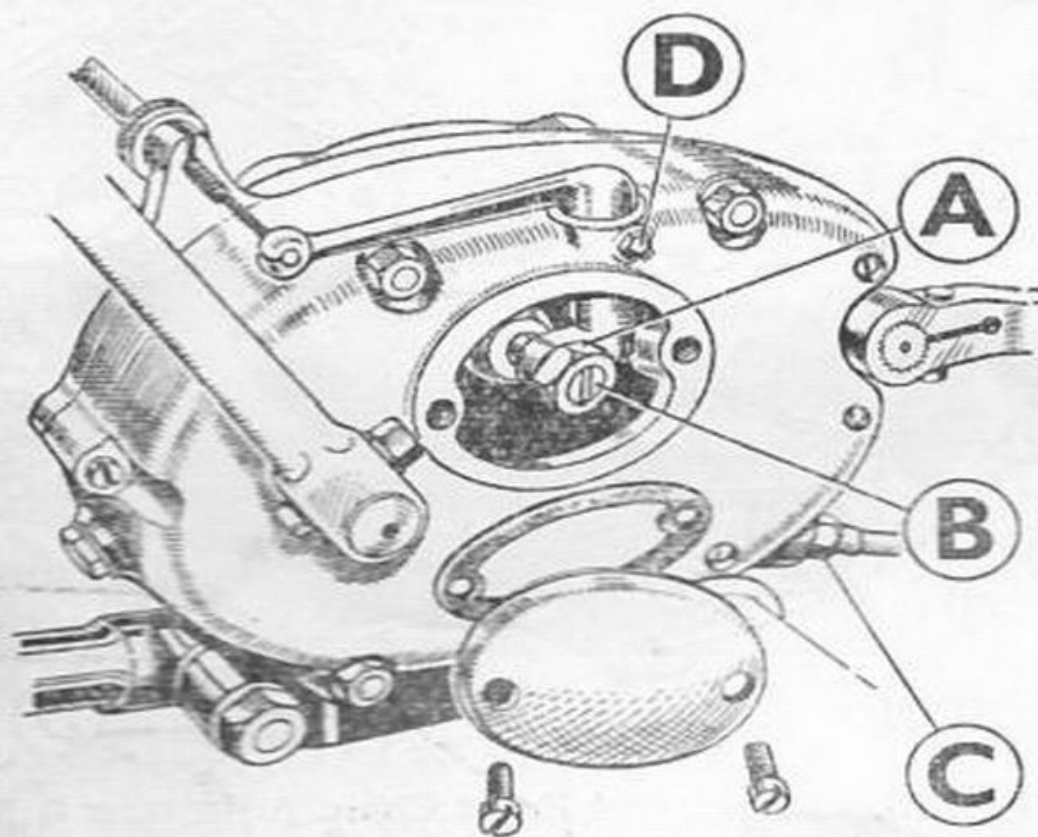

Fig. 14. Clutch Control Adjustment.  
(A10 G.F. Plunger model).

*Adjusting pins D.* Release the locknuts *C* and screw outwards against the wheel spindle. Move the latter backwards until there is not less than  $1\frac{1}{2}$  in. total up and down movement at the centre of the bottom run of the chain. To allow for any variation in chain tension the wheel should be rotated by hand until the tightest point is found, with the wheel in its lowest position. The two adjusters must be turned equally otherwise the wheel alignment will be affected. (See page 44)

*Re-tighten the sleeve nut A, and tighten the spindle B very firmly.*

*Adjust the rear brake to suit requirements*



**Rear Chain.** (A10 G.F. Plunger model).

*Set the machine on its stand.* The rear wheel must be in its lowest position in the suspension unit, for the purposes of this adjustment. (See Fig. 17).

*The rear brake adjuster.* This must be slacked off, otherwise the brake rod may prevent full movement of the wheel.

Hold a spanner on the hexagon *A* and insert a tommy bar into the spindle head *C* and unscrew it a little (right-hand thread), until the inner sleeve nut *B* can be slacked sufficiently to allow movement of the rear wheel.

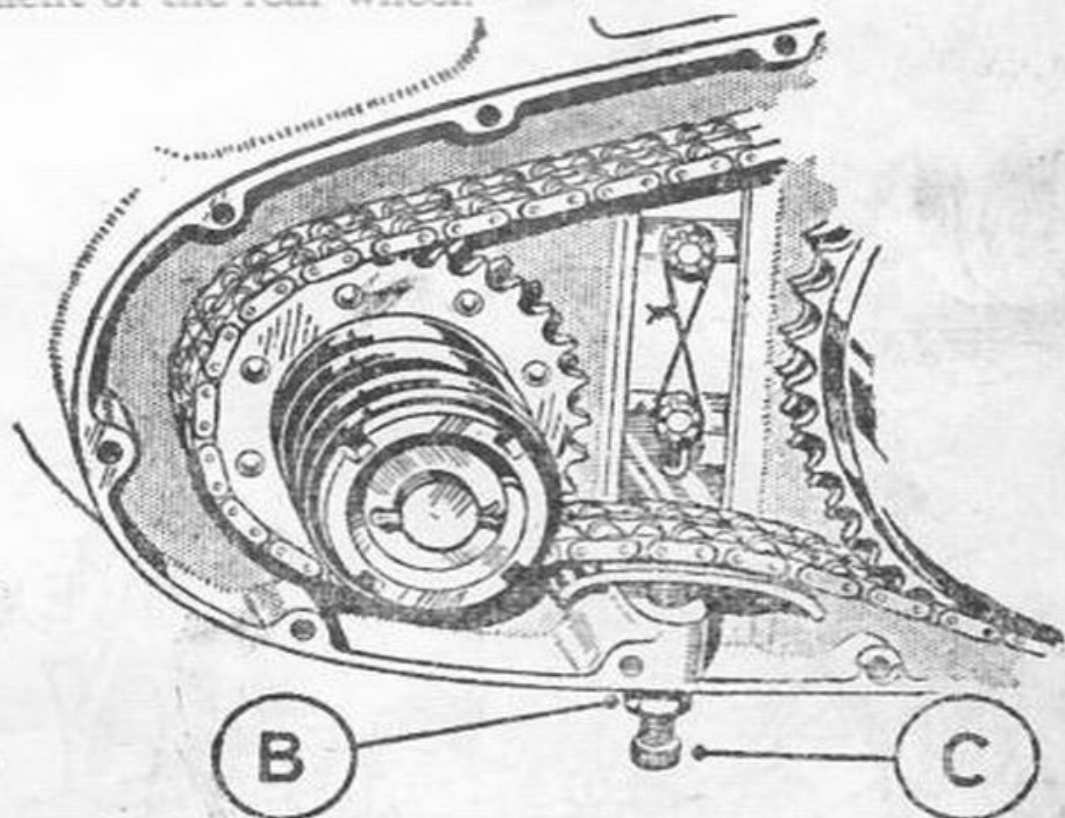

Fig. 15. Primary Chain Adjustment  
(A10 G.F. Plunger model).

*Adjusting pins D.* Screw inwards against the wheel spindle. Move the latter backwards until there is a total up and down movement of half-an-inch at the centre of the chain span. The two adjusters must be turned equally otherwise the wheel alignment will be affected. (See page 44).

*Re-tighten the sleeve nut B.* Replace the outer nut *A* and tighten the spindle at *C* and locknut *A* very firmly.

*Adjust the rear brake to suit requirements.*

**Clutch Control.** (See Fig. 13).

The clutch operating mechanism is totally enclosed in the gearbox outer cover, and adjustment is a simple matter, if carried out in the following manner:

*The inspection cover.* Remove this and take care not to damage the gasket.

*Locknut G.* Slacken this nut just sufficiently to allow movement of the screw *H*.

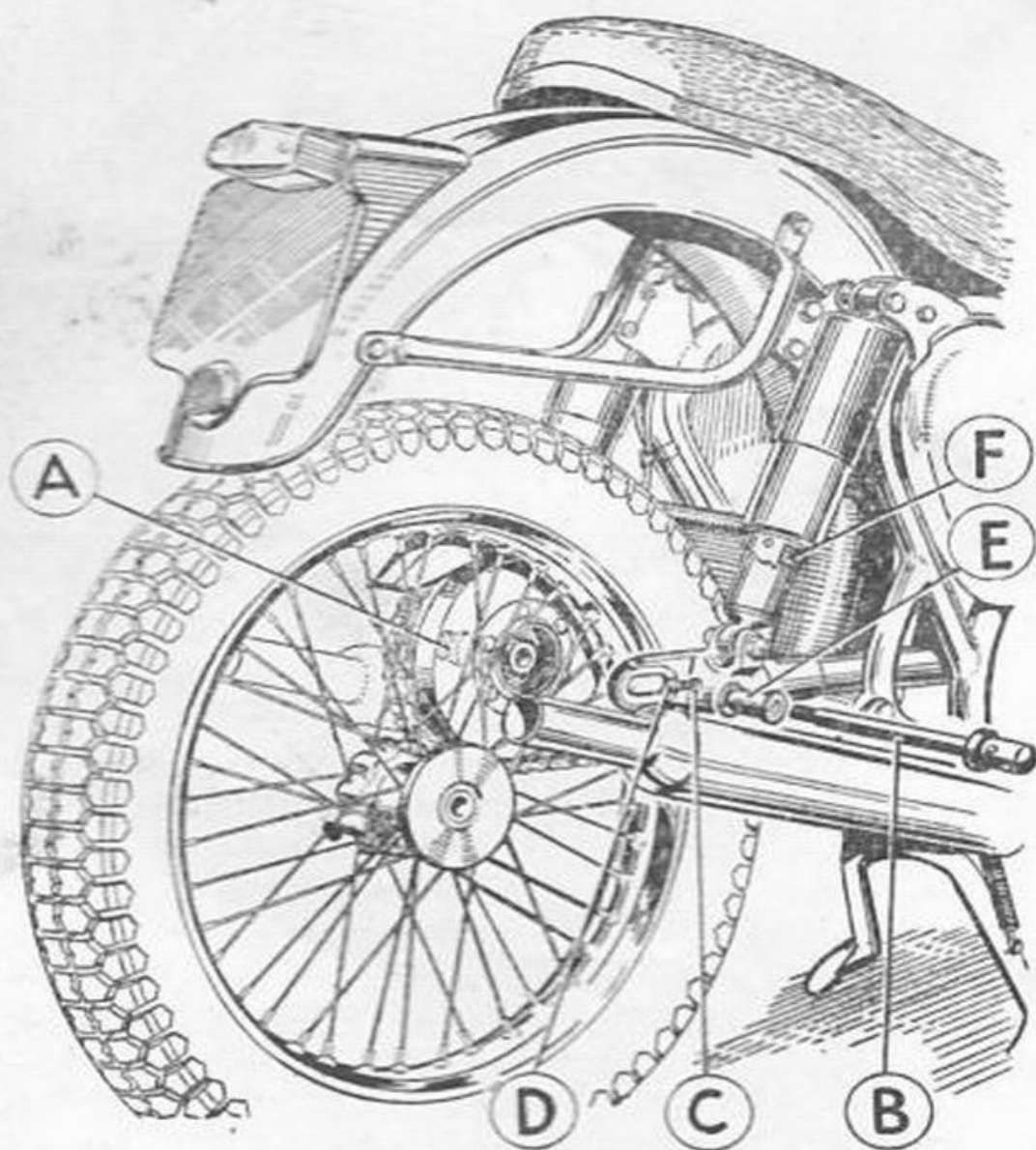

Fig. 16. Rear Chain Adjustment  
(Swinging Arm Frame).

*The screw H.* Adjust with a screwdriver, so that there is just a trace of play between the inner end of the pin and the clutch operating rod. This is essential to ensure that the clutch engages fully.

*The locknut G.* When re-tightening this nut after completing the adjustment make sure that the adjustment is not distributed.

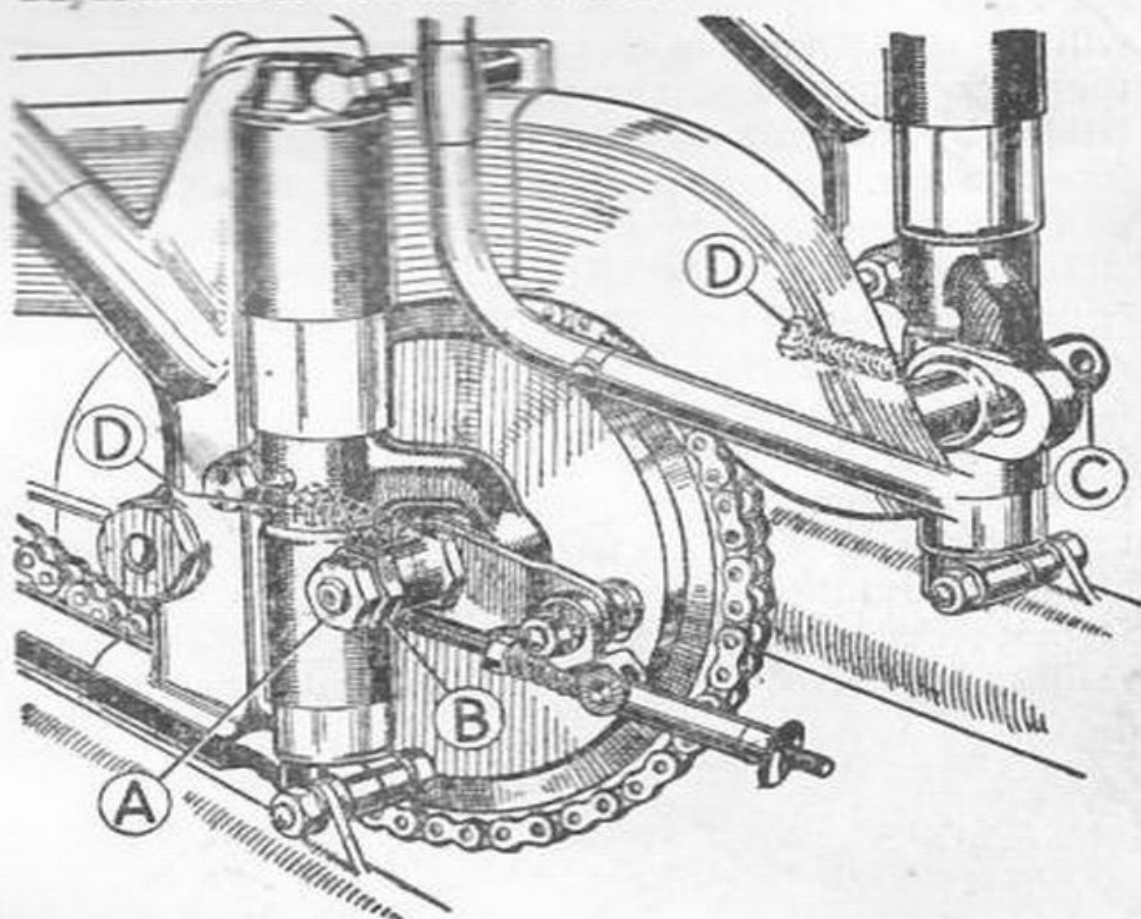

Fig. 17. Rear Chain Adjustment  
(A10 G.F. Plunger model).

In addition, finger adjustment to the length of the cable is provided by the adjuster above the gearbox.

Remember, however, that some free movement in the control arm is necessary, as if the adjustment is too tight, there will be constant pressure on the clutch, with consequent wear and loss of efficiency.

**A10 G.F.** (Plunger model).

The instructions for clutch adjustment are identical with the above. (See Fig. 14, *A* and *B*).



### Clutch Spring Adjustment.

After considerable mileage it may be desirable to increase the spring pressure a little. First remove the outer half of the primary chain case, noting the positions of the various screws for replacement purposes, particularly the red painted screws, *A* and *B*, see Fig. 5. The clutch will then be exposed and it will be seen that the clutch plates are compressed together by springs, the pressure of which is controlled by the nuts *B* and locknuts *A* (Fig. 18). To increase the spring pressure, release the locknuts and tighten the nuts *B* slightly. It is important that each of the six adjusting nuts is tightened equally to ensure even pressure, otherwise the plates will slide unevenly and clutch drag will result. After the adjustment is completed, depress the clutch lever and spin the clutch by operating the kickstarter, when the outer plate should be seen to revolve parallel with the other plates. If not, adjust individual springs until the plates are true. Replace the primary chaincase with its washer and refill to the correct level. See technical data, page 4.

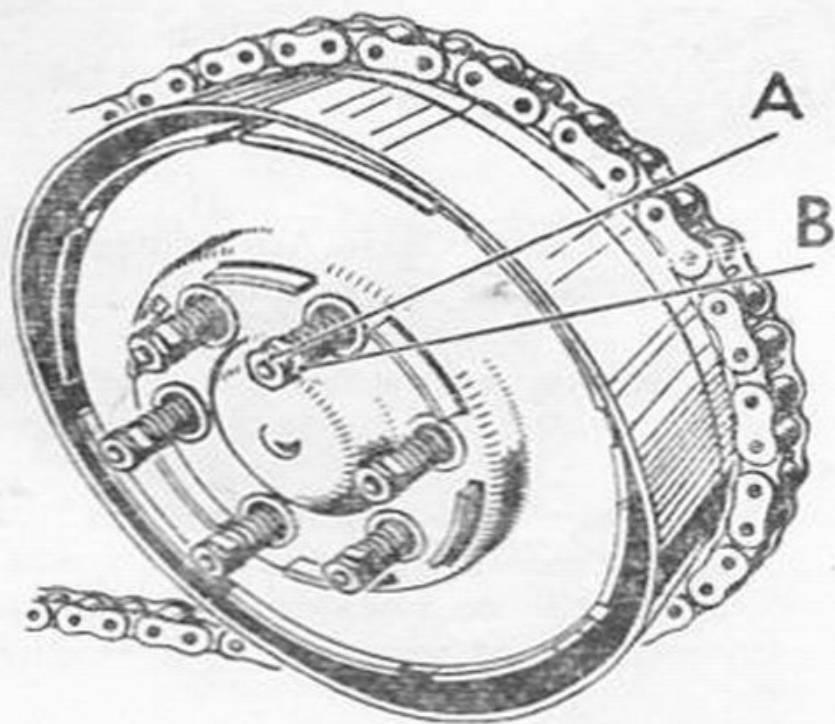

Fig. 18. Clutch Spring Adjustment  
(Swinging Arm models).

### Clutch Spring Adjustment. (A10 G.F. Plunger model).

The instructions for clutch spring adjustment are identical with the above except for the following:

In particular note the position of the red screw.

A clutch cover *A* (Fig. 19) is fitted and this is held on by twelve screws and spring washers. No locknuts are used on this clutch.

*Note.*—Only one red painted screw is used in the chaincase on this model. (See Fig. 6).

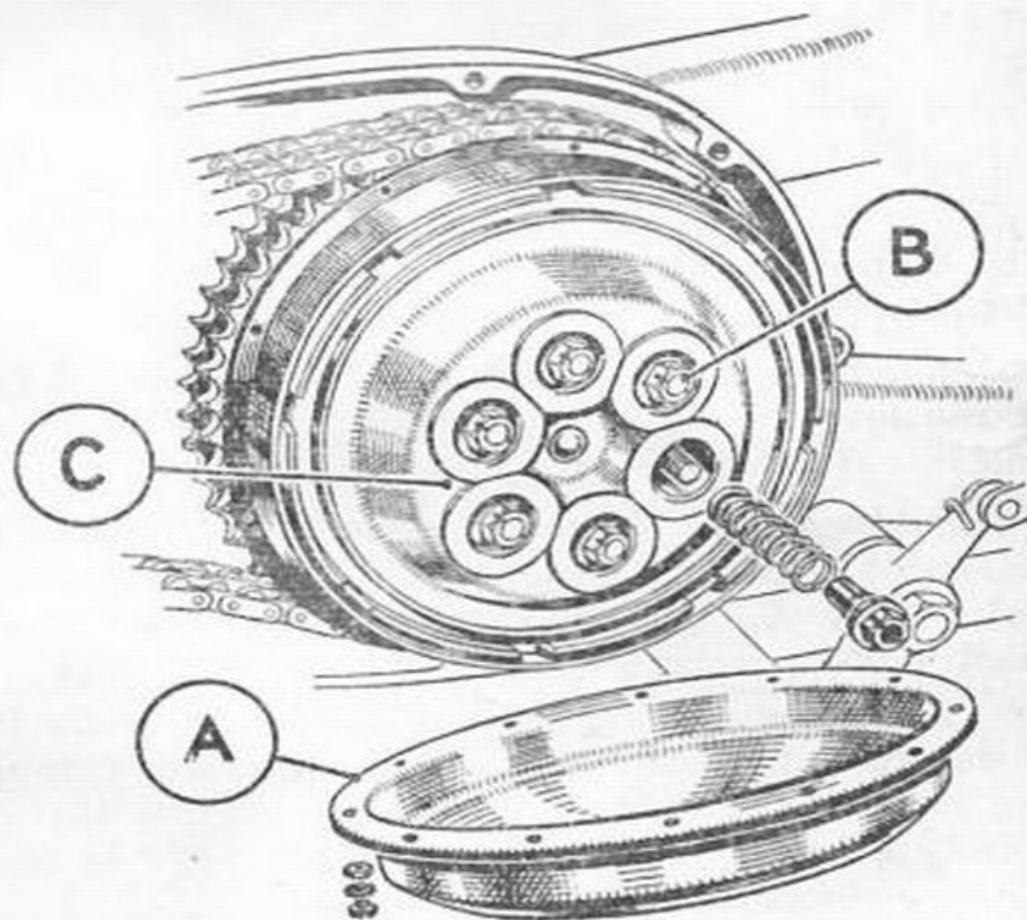

Fig. 19. Clutch Spring Adjustment  
(A10 G.F. Plunger model).

### Chain Lubrication.

It is a good plan to remove the rear chain periodically, clean it thoroughly in petrol or paraffin, and then gently warm in a mixture of grease and graphite. When cool, wipe off excess grease, clean the sprockets and replace the chains.

Remember, when replacing a chain fitted with a detachable connecting link, that the spring fastener must always be put on with the closed end facing the forward direction of travel of the chain (i.e., on the top run).

### III. WHEELS

#### Front Wheel Bearings.

The hub is fitted with ball journal bearings and adjustment is not required.

#### Front Wheel Removal.

Dismantle the assembly in the following order:

*The brake anchor strap.* Take off the nut *C* Fig. 20 on the cover plate, and slacken the nuts *D* at the opposite ends of the strap.

*The brake cable.* The must be uncoupled first at the lever *E* on the brake cover plate and then unscrewed from the stop *F*.

*Pinch bolt A.* The wheel spindle is locked by means of this bolt, which is fitted to the nearside fork leg only. It is only necessary to slacken the pinch bolt.

*The wheel spindle.* To unscrew, a tommy bar of suitable dimension should be inserted through the hole in the spindle head at *B*. Note that the spindle has a left-hand thread and unscrews by turning in a clockwise direction.

*Withdraw the spindle from the nearside.* Support the weight of the wheel when taking out the spindle, and the wheel can then be removed.

After removal, do not let the weight of the wheel fall on to the bush which projects from the brake side of the hub. Although the bush is pressed in, it may, if subjected to a sharp blow, fall inside the cover plate, so that the latter would have to be removed before the bush could be retrieved and located in position.



### Front Wheel Replacement.

The brake anchor strap must be replaced carefully, otherwise the brake will be inoperative.

Before the pinch bolt *A* is tightened, the forks must be depressed sharply several times to enable the nearside fork leg to align itself on the spindle. If this precaution is not observed, the leg may not

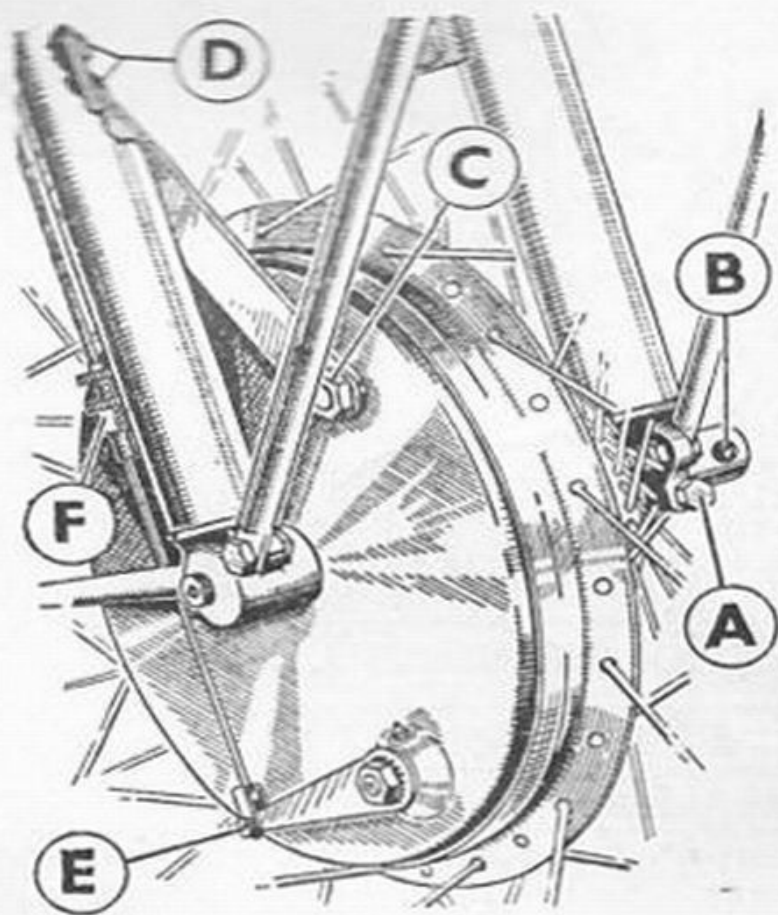

Fig. 20. Front Wheel Removal.

be aligned properly, in which case it will not function correctly. Do not forget to tighten the pinch bolt.

### Rear Wheel Bearings.

The hub is fitted with ball journal bearings and adjustment is not required.

## A10 PLUNGER MODEL

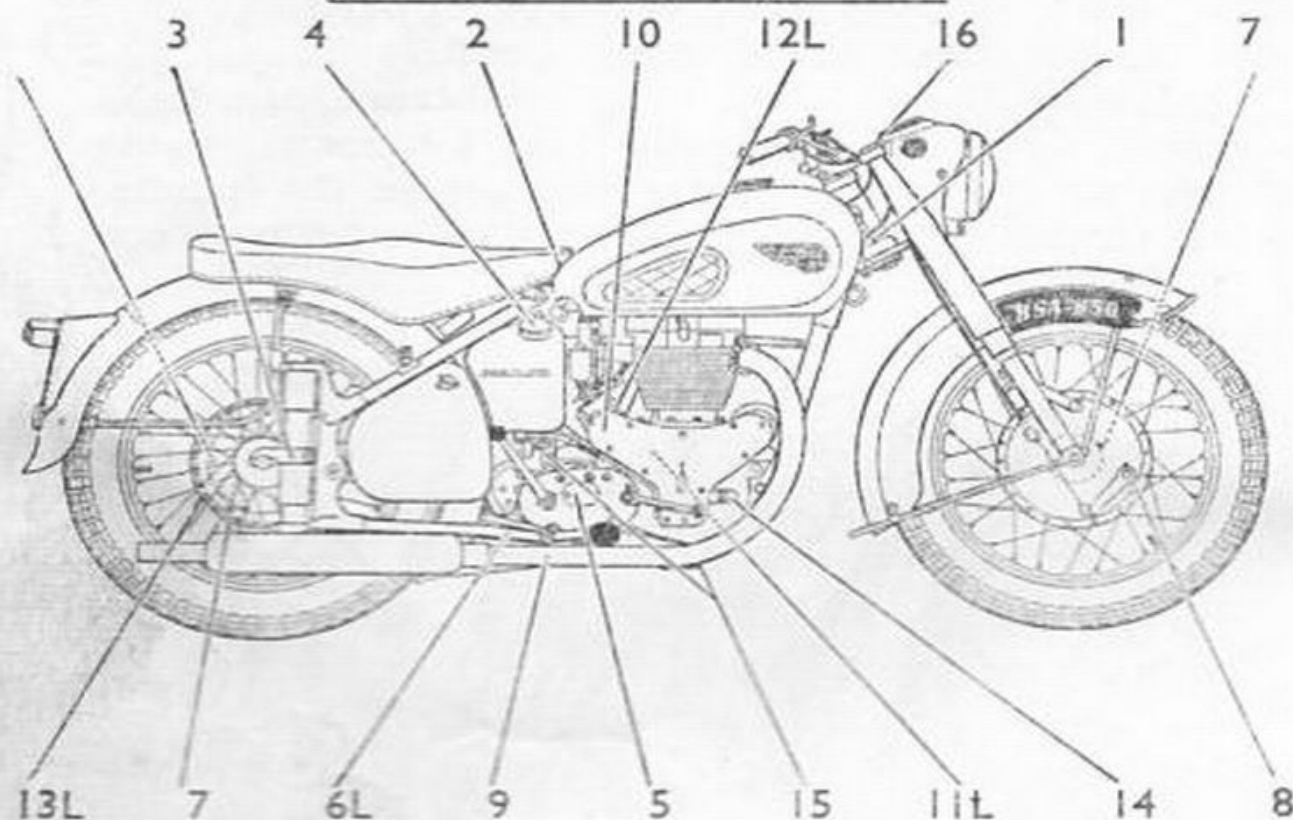

**KEY LUBRICATION POINTS**  
(L indicates left-hand side, remainder right-hand or both sides).

### RECOMMENDED LUBRICANTS

| ENGINE OILS  |           |           | FRONT FORKS | GREASE            |
|--------------|-----------|-----------|-------------|-------------------|
| Brand        | Summer    | Winter    |             |                   |
| Mobiloil     | BB        | A         | Arctic      | Mobilgrease No. 2 |
| Shell        | X100-40   | X100-30   | X100-20     | Retinax A or CD   |
| Castrol      | XXL       | XL        | Castrolite  | Castrolase Heavy  |
| Esso         | 40        | 30        | 20          | Essogrease        |
| B.P. Energol | S.A.E. 40 | S.A.E. 30 | S.A.E. 20   | Energrease C3     |

**FOR OVERSEAS.** Recommendations as above if obtainable. If not, the following rule should be observed:—The higher the temperature the higher is the S.A.E. number required.

|                    |   |        |                         |
|--------------------|---|--------|-------------------------|
| Engine and Gearbox | } | Summer | S.A.E. 40—50            |
|                    |   | Winter | S.A.E. 40—50            |
| Front Forks        |   |        | S.A.E. 20 (see page 47) |

## Swinging Arm Models

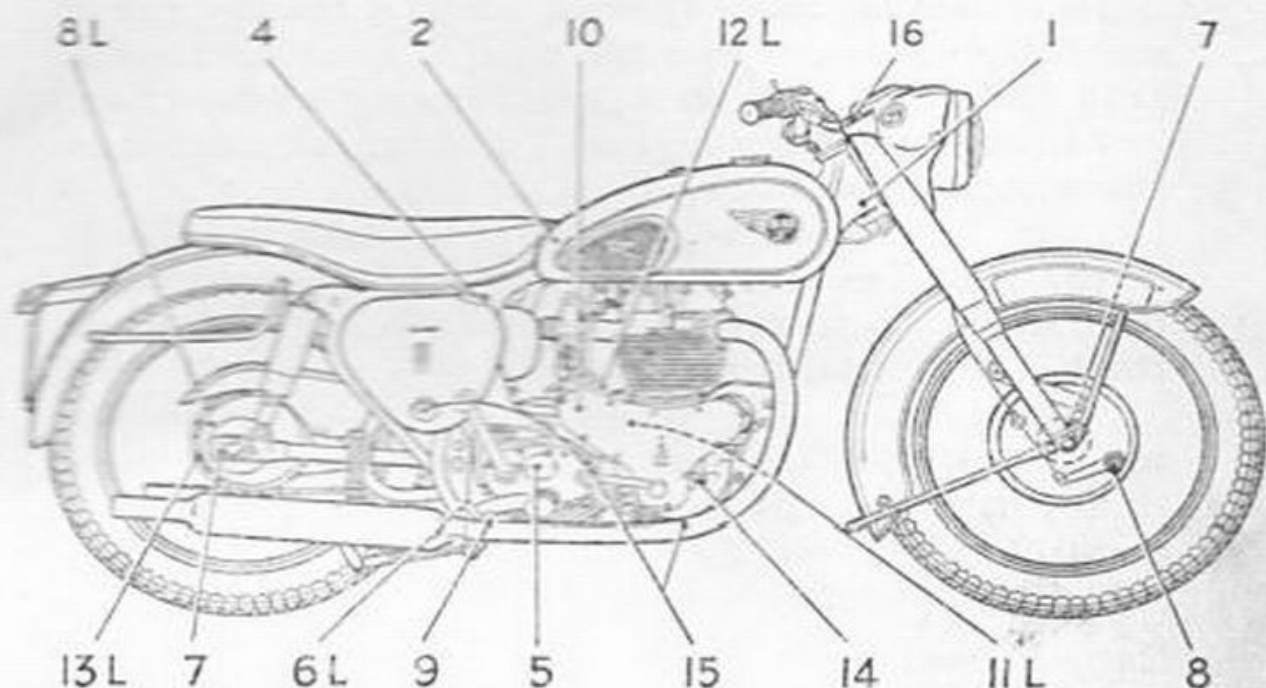

|                                  | Ref.  | GREASE   | Pge | Ref.       | OIL                        | Pge      |
|----------------------------------|-------|--|-----|------------|----------------------------|----------|
| <b>LUBRICATION/<br/>WEEKLY</b>   | 1     | Steering Head  | 18  | 4          | Oil Tank                   | 18       |
|                                  | 2     | Saddle Nose Bolt<br>(except Dual Seat)                           | 18  | 5          | Gearbox                    | 18       |
|                                  | 3     | Rear Suspension  | 18  | 6          | Brake Pedal                | 18       |
|                                  | —     | Sidecar Rear<br>Connection                                       | 18  | —          | Control Joints             | 18       |
|                                  | —     | Sidecar Spring<br>Shackles                                       | 18  | —          | Exposed Cables             | 18       |
| <b>EVERY<br/>1,000<br/>MILES</b> | 7     | Hubs   | 19  | 8          | Rear Brake Cam<br>Spindles | 19       |
|                                  | —     | Clutch control arm   | 19  |            |                            |          |
|                                  | 8     | Front Brake Cam<br>Spindle                                       | 19  |            |                            |          |
| <b>EVERY<br/>2,000<br/>MILES</b> | 9     | Central Stand  | 22  | 4          | Oil Tank                   | 20       |
|                                  |       |  |     | 5          | Gearbox                    | 20       |
|                                  |       |  |     | 10         | Auto. & Manual<br>Advance  | 21<br>72 |
|                                  |       |  |     | 11         | Primary Chain<br>Oilbath   | 21       |
|                                  |       |  |     | 12         | Magneto                    | 22       |
|                                  |       |  | 13  | Rear Chain | 22                         |          |
| <b>SPECIAL<br/>NOTES</b>         |       | Examine engine pressure valve at 1,000 miles (see<br>A, Fig. 2). |     |            |                            |          |
|                                  | 15.   | Clean oil tank and crankcase filters at 2,000 miles.             |     |            |                            |          |
|                                  | 16.   | Check front fork oil level at 10,000 miles.                      |     |            |                            |          |
|                                  | 4, 5. | Drain and refill oil tank and gearbox at 2,000 miles.            |     |            |                            |          |



### Rear Wheel Removal.

To remove the wheel spindle, insert a tommy bar of suitable dimensions into the head of the spindle at *B* (Fig. 16), and turn in an anti-clockwise direction.

The distance piece *E*, may, in fact, fall out when the spindle is withdrawn.

To withdraw the wheel. Pull it towards the offside of the machine into the space made by removal of bush *E*, as so to disengage the coupling splines on the hub from the brake drum.

*Special note.* The sleeve nut *A* should not be touched during the above operation. The only time this nut needs to be released is during adjustment of the rear chain.

### Rear Wheel Removal. (A10 G.F. Plunger model)

The mudguard tail is hinged to facilitate removal of the wheel. Disconnect the tail lamp wire at the coupling specially provided for this purpose, and slacken the nuts at the fixing stays.

Hold a spanner on the outer hexagon *C*, see Fig. 21.

To remove the wheel spindle, insert a tommy bar of suitable dimensions into the spindle head at *A* and turn in an anti clockwise direction.

The distance piece *B* may, in fact, fall out when the spindle is withdrawn.

To withdraw the wheel. Pull it towards the offside of the machine into the space made by removal of distance piece *B*, so as to disengage the coupling splines on the hub from the brake drum.

*Special note.* The large sleeve nut behind *C* should not be touched during the above operation. The only time this nut needs to be released is during adjustment of the rear chain, see page 35.

### Wheel Alignment (Solo).

Whenever any adjustment has been made to the rear chain it is advisable to examine the wheels for alignment, since, if this is incorrect the steering will be unsatisfactory and undue wear will take place on the sprockets, chains, etc.

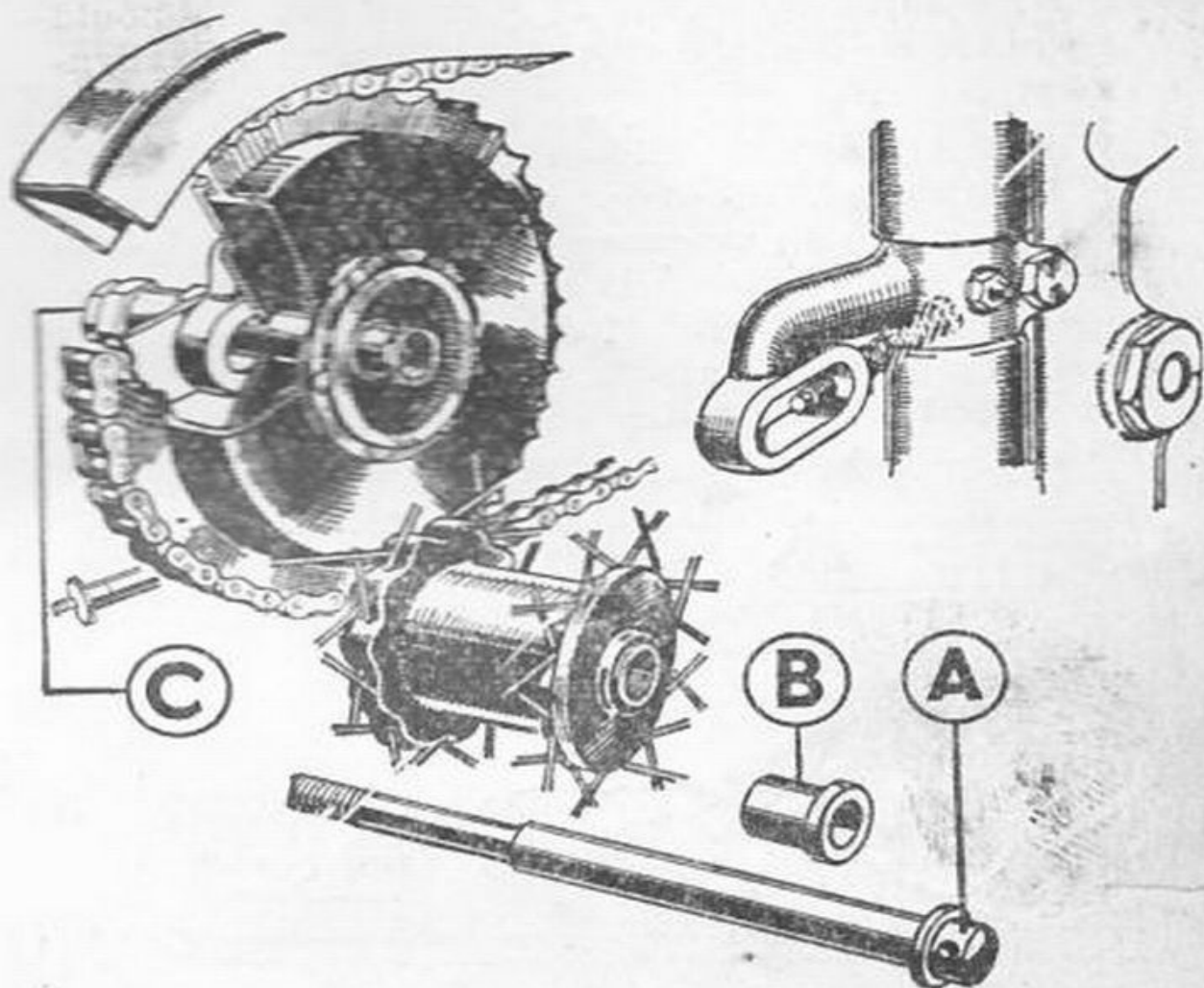

Fig. 21. Rear Wheel Removal  
(A10 G.F. Plunger model).

Check that the wheel spindle is firmly against the adjusting screws *D*, Figs. 16 and 17. This should, of course, be the normal condition after chain adjustment.

Apply a straight edge along the sides of the wheels. A narrow plank is a suitable gauge, but it must be remembered that the edge must be stepped to suit the difference in tyre sizes between front and rear wheels. Apply the gauge at a point immediately below the silencers and keep in a horizontal position.

Check for fit. With the front wheel set straight ahead, the gauge should touch both wheels at two points.

Re-adjust if necessary. This should be carried out in a manner similar to that for rear chain adjustment (pages 33, 35 for A10 G.F. Plunger model).

but the adjusting screws *D*, Figs. 16 and 17, should be re-set so that the wheels conform to the alignment gauge.

### Wheel Alignment (Sidecar).

Faulty alignment of the sidecar chassis will cause heavy steering, excessive tyre wear and undue strains on the frame. It is worth while, therefore, spending a great deal of care in making sure that the alignment is correct. Adjustment is provided at several points on the B.S.A. chassis as indicated below.

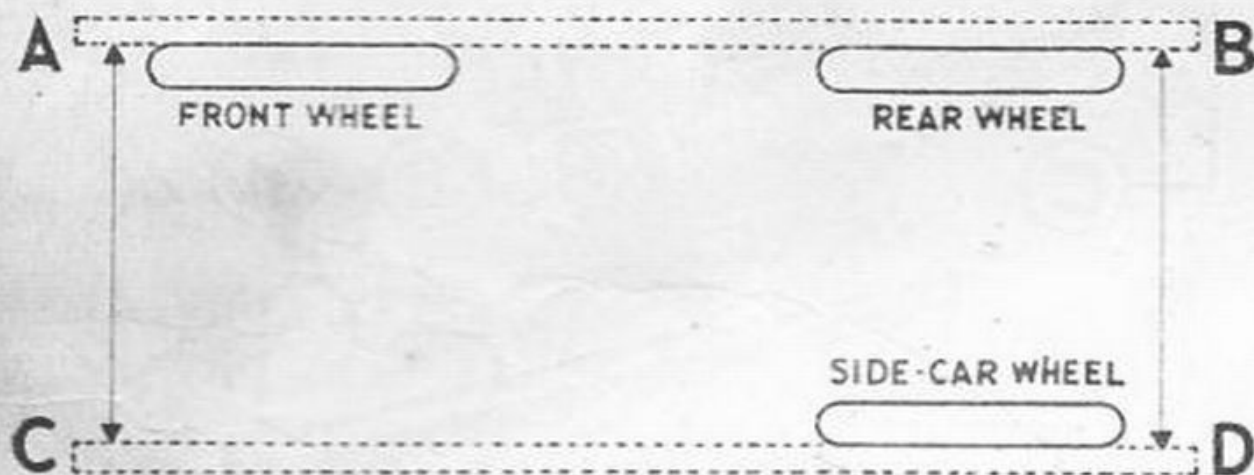

Fig. 22. Sidecar Alignment.

*Check the alignment of the motor cycle alone.*

*Fit a straight edge against the sidecar wheel as shown in Fig. 22.*

*Measure distances A—C and B—D. These should differ by half-an-inch, A—C being the smaller of the two dimensions.*

*Adjust if necessary.* The two front connections to the frame can be varied for length. The lower one is of the telescopic type and it is only necessary to release the clip bolt on the connecting lug at the crankcase when the tube may be telescoped in or out as required. The upper connection is adjustable at the chassis. Release the clip bolt on the chassis lug and slide the tube through the lug as required.

*Examine the rear connection.* This is fitted with spring loaded spherical seatings to facilitate vertical alignment. Tighten the nut securing the rear con-



nection to the chainstay and then slacken it back sufficiently to allow insertion of the split pin.

*Examine the vertical alignment.* It is important that the machine should be leaning slightly outwards, i.e., away from the sidecar. The connection to the seat lug is telescopic and can be adjusted to suit.

*Check all connections.* Make certain that all nuts are tight and split pins fitted where required.

#### IV. SUSPENSION AND STEERING

##### Front Forks.

If after considerable mileage the forks appear to develop excessive up-and-down movement, replenish the hydraulic damping system as follows.

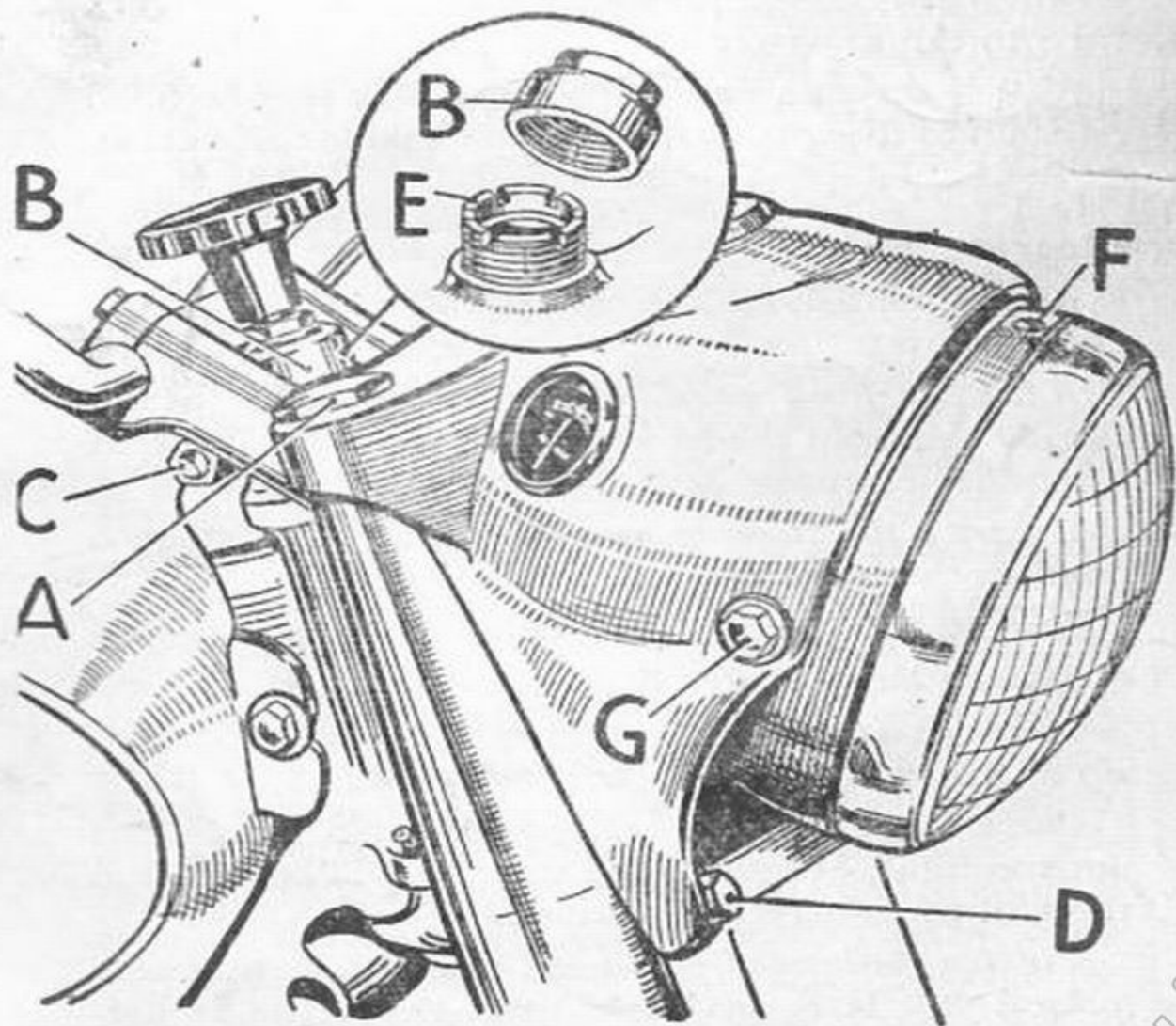

Fig. 23. Front Fork and Steering Head.

*Remove the hexagon headed cap A (Fig. 23), at the top of each fork leg. A special spanner is provided in the kit for this purpose.*

*Unscrew the drain plug (Fig. 24) at the bottom of each fork tube.*

*Drain out the old oil. It will help this operation if the owner stands astride the machine, grasps the handle bars, and oscillates the forks sharply up and down a few times.*

*Replace the drain plugs.*

*Add 8 fl. oz. (225 c.c.) of oil to each leg, for A10 G.F. Plunger model, add 4 fl. oz. (100 c.c.) (see lubrication chart), the filling orifice being at A (Fig. 23)*

*Replace the caps at A. These must be screwed down tightly since primarily they anchor the fork tube to the top yoke.*

*Note.—On no account must the fork legs be filled right up to the top, or they will be unable to function.*

### **Steering Head.**

Adjustment should be carried out in the sequence given below:

*Raise the front wheel clear of the ground. Stand astride the front wheel and lift it while an assistant places a box underneath the crankcase.*

*Unscrew the steering damper knob. The stem is fixed to the knob and will unscrew with it.*

*Remove the steering head locknut B (Fig. 23).*

*Slacken the head clip bolt C.*

*Turn the adjusting sleeve E until all slackness (i.e., up and down play) has been taken up.*

*Check the adjustment. Make sure that sleeve E is not too tight, otherwise the steering will be stiff and the ball races may be damaged.*

*Tighten the head clip bolt at C and the steering head locknut B. It is advisable to re-check the adjustment at this stage, and if satisfactory the damper knob may be refitted.*

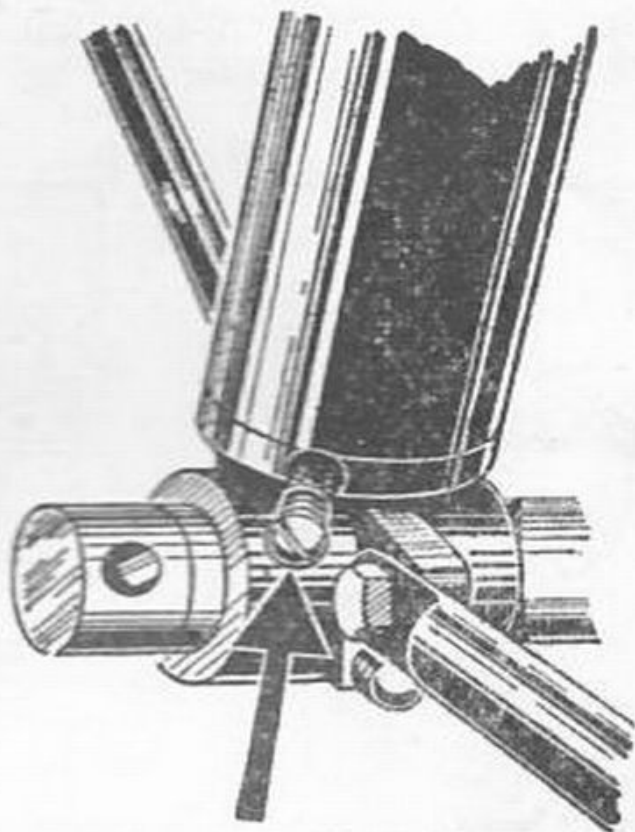

Fig. 24. Front Fork Drain Plug.

### Rear Suspension.

This suspension system incorporates two suspension units each comprising a totally enclosed compression spring and an automatic hydraulic damping device.

The hydraulic dampers are entirely self-contained, and require no maintenance whatsoever. These are correctly adjusted at the Works during manufacture, and call for no subsequent attention.

The springs fitted to the B.S.A. suspension units are adjustable for load, three positions being provided as seen in the illustrations below. When sent out the springs are normally set in the lowest position, as seen on the left. If it is felt that conditions call for slightly stiffer springing due to the rider's weight, or the nature of the ground, this can be arranged in a matter of seconds by using the Cee-spanners supplied in the toolkit in order to turn the adjuster cams to the second position as shown in the middle illustration. On and after frame No. CA7.413 the lower cam ring is fixed to the body so that only one 'C' spanner is required for adjustment.



purposes (see *F*, Fig. 25). A little oil on the cam faces will facilitate this operation.

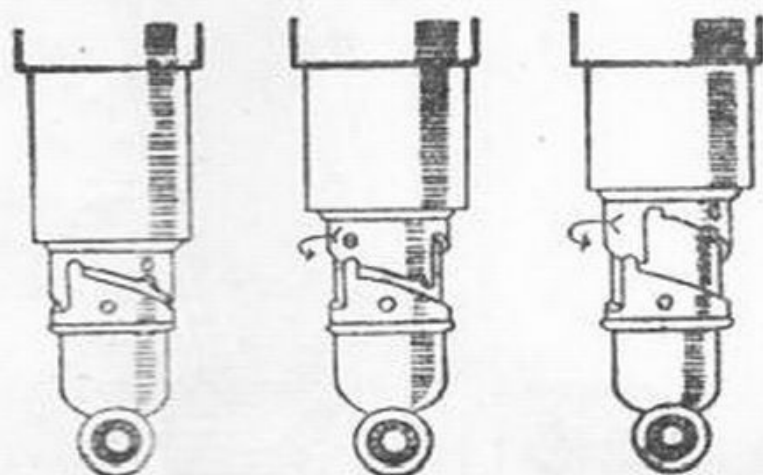

Fig. 25.

If a pillion passenger or luggage is carried it will be necessary to set the suspension units in the highest position, turning the cams to the third position as shown on the right.

The frame pivot requires no lubrication as this is fitted with silentbloc bushes.

#### **Rear Suspension.** (A10 G.F. Plunger model).

Under normal running conditions the rear suspension should not need any attention other than that of lubrication. If however, it is decided to dismantle the assembly for any reason this should be removed in the following sequence:

*The rear wheel.* Instructions for removing this are given on page 44.

*Brake assembly.* This involves uncoupling the rear chain and brake rod. Finally unscrew sleeve *C* (Fig. 21).

*Pinch bolts.* These are located at the top and bottom of the suspension unit as shown at *B* and *A* (Fig. 26), and after removing the latter the silencers can be taken off.

*The centre columns.* Tap them upwards and take out through the top lugs.

*The spring units.* Each unit will slide sideways from between the top and bottom lugs, and can be completely dismantled on the bench. If necessary, the wheel spindle brackets can be detached from the bearing sleeves after removal of pinch bolts *D*.

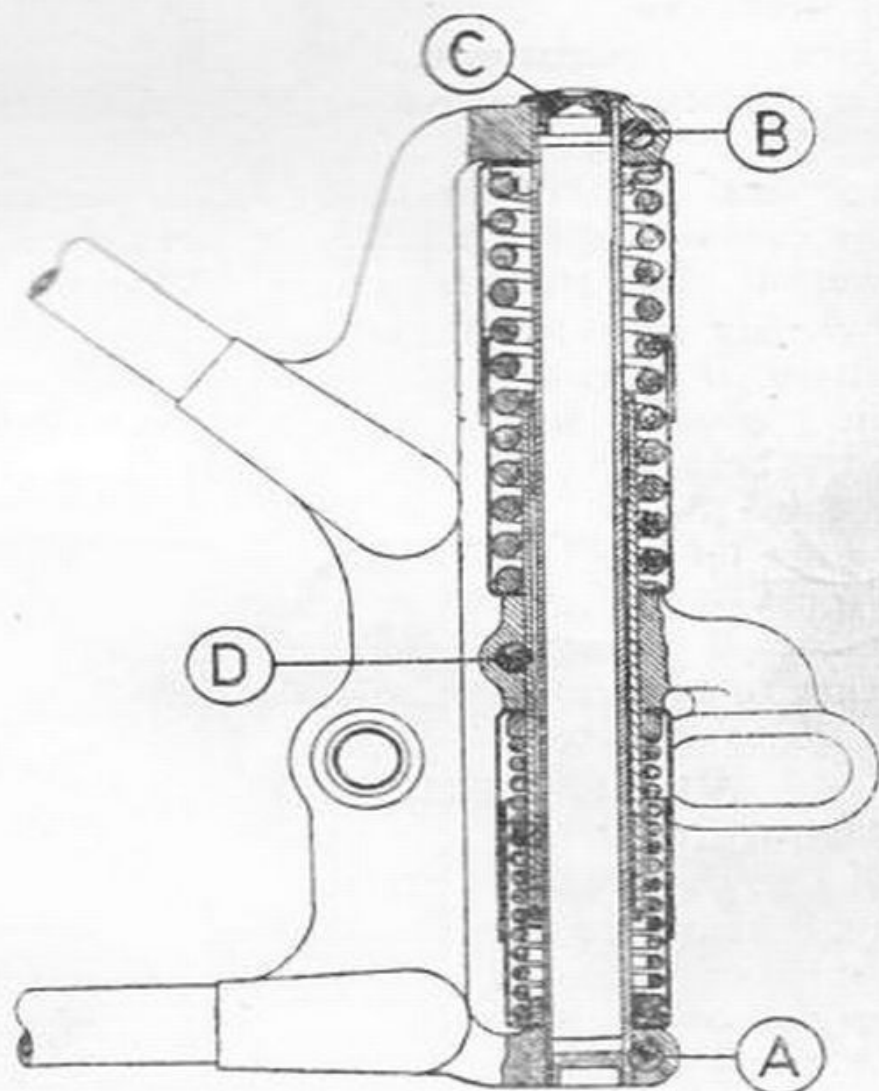

Fig. 26. Rear Suspension Unit  
(A10 G.F. Plunger model).

*Re-assembly notes.* The pinch bolts at *D* and *A* engage with notches in their respective sleeves and particular attention must be paid to their correct positioning. The projecting peg on the brake cover plate must fit properly into its slot in the frame, otherwise the brake will be inoperative.

## V. BRAKES

It is vital that the brakes are kept in good condition (see 'Hubs,' page 19).

### Front Brake Adjustment.

The length of the brake cable can be altered at its lower end at *F*, Fig. 20, the adjuster being operated by the fingers.

### Rear Brake Adjustment.

Finger adjustment is provided at the end of brake rod.

Do not set the brakes too closely, since, particularly in the case of the front brake, its action may be too powerful. Any friction between lining and drum will obviously impair the machine's performance. In addition, if carried to extremes, the heat may melt the grease in the hubs and this may find its way to the brake linings.

### Brake Cam Spindles.

These are lubricated as shown on page 19. Discretion must be exercised when lubricating, to ensure that lubricant does not reach the brake lining. Neglecting to lubricate the spindles may make the brakes stiff to operate.

## VI. CARBURATION

### The Carburetter.

So long as the engine continues to perform satisfactorily, the carburetter is best left alone, particularly by the inexperienced rider. The only adjustment in which the owner is likely to be interested is the pilot air screw (Fig. 28, Fig. 27 'Monobloc') which controls the slow running mixture. This is set before the machine leaves the works, but the best setting may vary slightly to suit rider's requirements, or different localities. Turning the pilot air screw inwards enriches the mixture, and unscrewing weakens it. A richer mixture gives a slower and more reliable tick-over, but it is naturally undesirable to have the mixture too rich, even with the throttle practically closed which is, of course, the throttle position for tick-over, so the best way to set the pilot air screw is to screw it in until the mixture is obviously too rich, and then unscrew it until the setting is



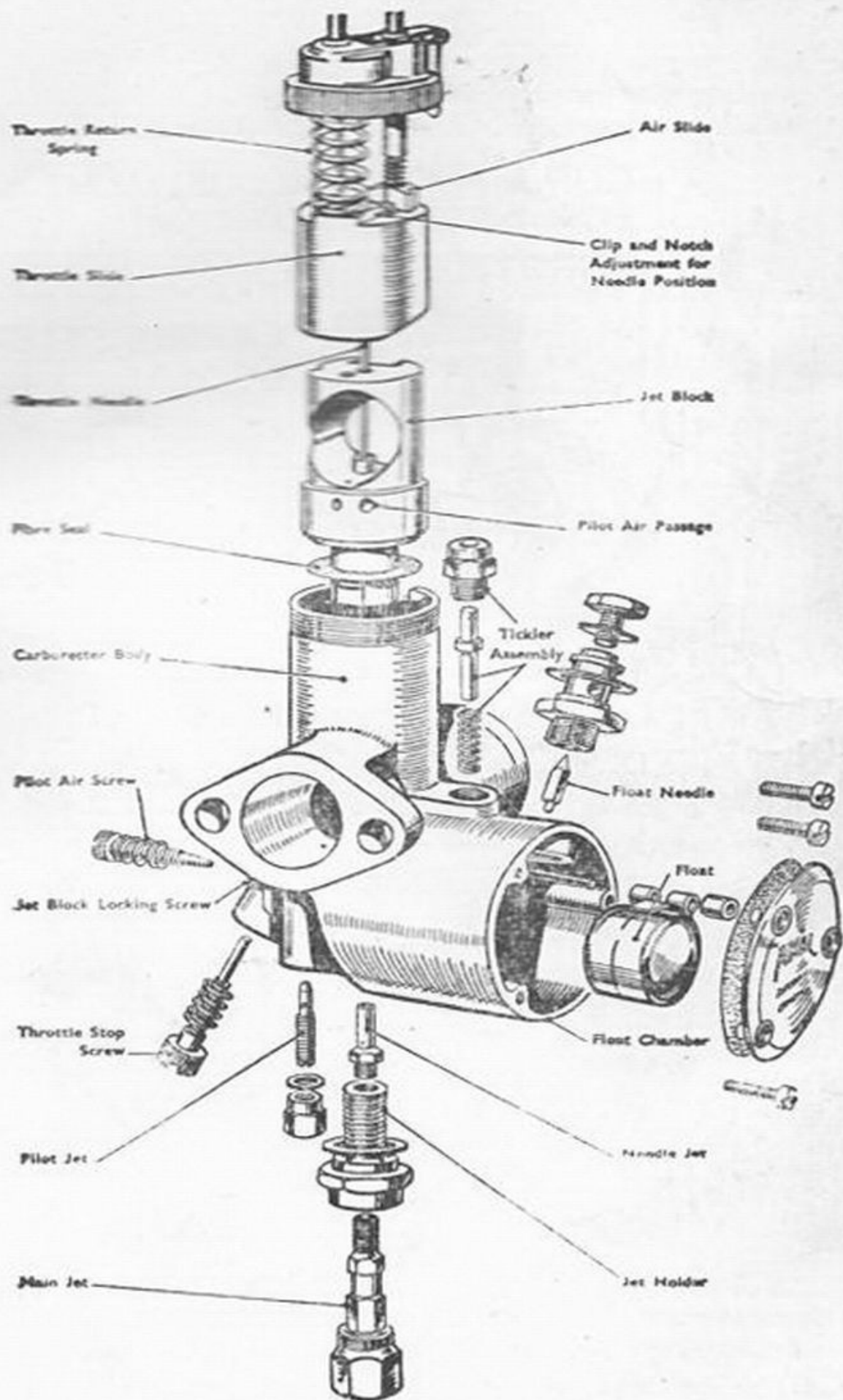

Fig. 27. Amal 'Monobloc' Carburettor.

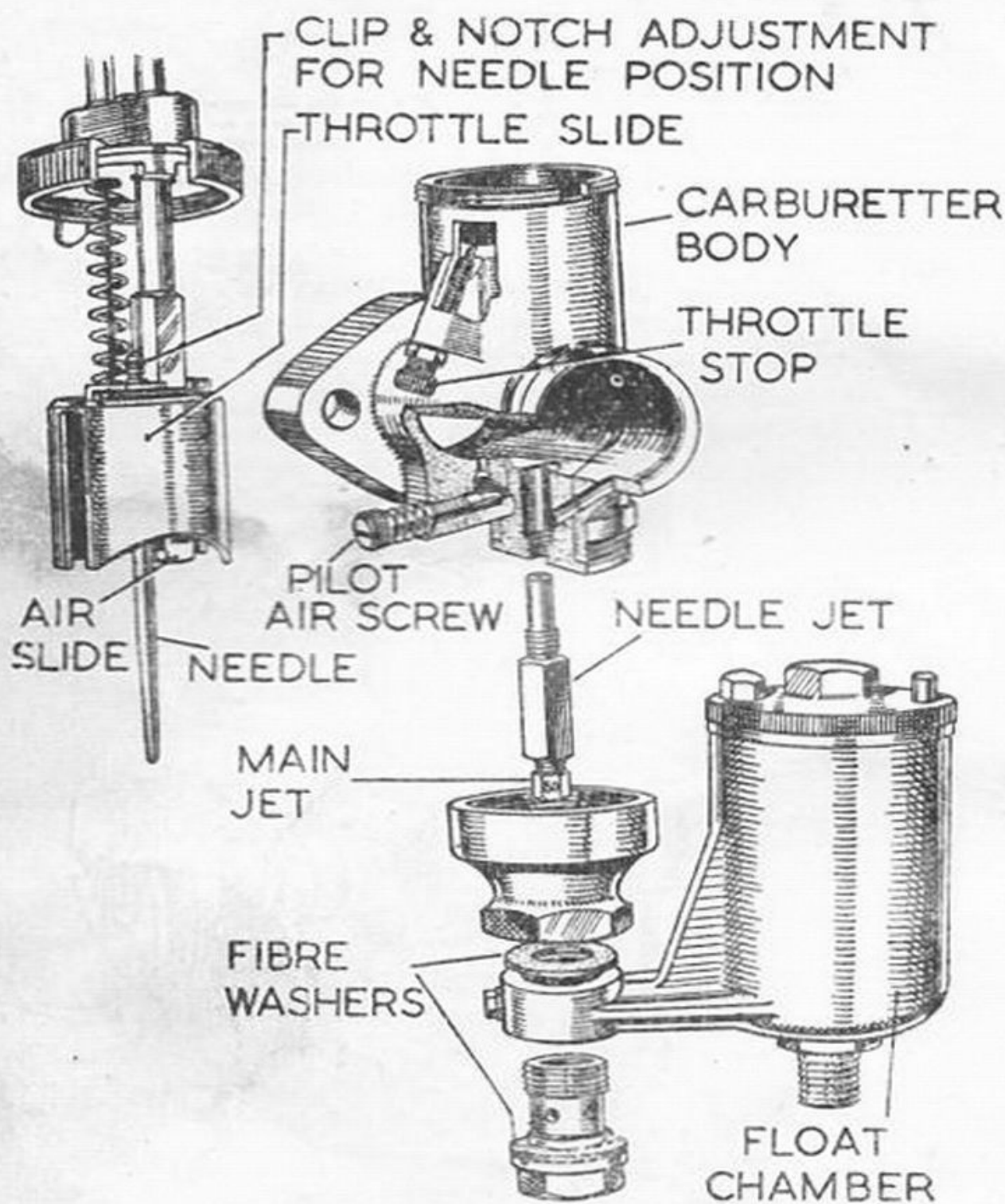

Fig. 28. Amal Carburetter.

just right, and further unscrewing increases the tick-over speed unduly. This may seem complicated, but the effect of altering the setting is very noticeable, and the rider will easily detect the symptoms.

It is doubly important to avoid over-richness of the tick-over setting if much riding is done on small throttle openings for this is what is known as running on the pilot, and if the pilot is too rich the general petrol consumption will be adversely affected.

The running mixture can only be altered by adjusting the height of the needle in the throttle valve or by fitting a main jet of different size. Such alterations should not be made except for very special purposes, as dictated by abnormal requirements, and only then on expert advice.

### **The Air Cleaner.**

This is fitted in front of the battery carrier, and is coupled to the carburetter by means of a rubber elbow. The filter element must be removed periodically for cleaning purposes when it should be washed thoroughly in petrol, allowed to dry, and then submerged in thin oil for a few minutes. Then take out, allow the surplus oil to drain off, and reassemble.

To gain access to the filter, the various items should be taken off in this order:

*The cleaner cover* is attached by two screws in elongated slots, the lower to the frame member below the seat and the other to the battery strap. The rubber connection to the carburetter should be left in position on the carburetter inlet stub and slipped off the cleaner cover.

*The filter* is held in the cleaner cover by five screws on the Shooting Star (when fitted), and a wire circlip on other models fitted with swinging arm rear suspension.

Detach and clean as above.

### **The Air Cleaner.** (A10 G.F. Plunger model).

This is contained in the back of the battery carrier, and is coupled to the carburetter by means of a rubber elbow. The filter element must be removed periodically for cleaning purposes when it



should be washed in petrol. *It must be dry before it is replaced.* To gain access to the filter, the various items should be taken off in this order:

*The battery.* Disconnect the battery leads at their unions (protected by rubber sleeves) and release the battery clamping plate.

*Battery carrier.* It is attached to the frame at three points, one to the backstay tube below the saddle and two to the seat tube. The rubber connection to the carburetter should be left in position on the carrier and slipped off the carburetter inlet stub.

*The filter.* This is held into the battery carrier by three screws. Detach and clean as above.

*Re-assembly notes.* Do not detach the rubber connection from the battery carrier. It is easier to dismantle and re-assemble the connection at the carburetter stub.

## DECARBONISING THE ENGINE

Decarbonising should only be carried out when the engine really needs it. The usual symptoms are an increased tendency to 'pink' (a metallic knocking when under heavy load) due to the building up of carbon on the tops of the pistons and inside the cylinder heads, a general falling off of power noticeable on hills and a tendency for the engine to run hotter than usual.

### **Preliminary Work.**

Remove in the following order:

**Petrol tank.** First turn off the petrol taps and detach the petrol pipes.

Remove the petrol tank strap which is located under the front of the tank and is held in position by two nuts.

### **Swinging Arm Models.**

The two or four gallon tanks fitted to these machines are of the quick release racing type, and are secured by one central bolt. This can be removed when the rubber cover in the top of the tank is pulled off.

## A10, G.F. Plunger Model.

Slacken nut securing the front of the tank to the steering head lug and remove the nut and stud holding the rear of the tank to the frame.

*Note.*—For re-assembly the position of the two distance collars between the tank and frame lugs.

*Sparking plugs.* Detach the high tension leads from the plugs by means of their quick action clips.

*Engine steady stays (D, Fig. 7).* Remove the stays from the rocker-box end only; slackening the nut at the frame end will enable the stays to be pivoted out of the way.

*Carburetter.* Take off the carburetter by removing the flange bolts and, on engines fitted with air cleaners, sliding it off sideways to disconnect the rubber sleeve at its junction with the carburetter. By unscrewing the ring nut at the top of the carburetter, the slides can be pulled right out and tied up to the top tube out of the way, while the main body of the instrument can be completely removed.

*Exhaust system.* Each pipe and silencer can be removed as a complete unit by taking off the nuts holding the silencer and pipe to the frame and gently knocking in the stud on the latter until the assembly comes away.

Knock the same stud in from the opposite side after removing the other pipe and silencer nuts.

## Dismantling for top overhaul.

Remove in the following order:

*Rocker box.* Remove the oil supply pipe banjos and the covers *A* (Fig. 7). It will be necessary to take out the front stud in the rear cover before the rocker box can be removed. This is accomplished by applying the special spanner provided in the tool kit to the flats machined on the stud which is exposed when the cover is taken off. Finally remove the five bolts, including the one inside the rear cover aperture, four nuts under the rocker box, and lift off the box.

*Push rods.* These can now be lifted out.

*Cylinder head.* Remove the nine bolts, the central one first (see Fig. 10). If it shows a tendency to stick, a few light taps with a wooden mallet under the exhaust ports will loosen it.

*Cylinder head gasket.* Examine this carefully for defects. If it is not sound and bright, has black-stained patches, especially between the cylinder bores, this may indicate blow or leakage of gas and a new gasket should be obtained.

*Valves.* Place a wooden block, which will fit inside the cylinder head, on a bench, and lay the head over the block with the valve heads resting on it; compress the valve springs until the split collets can be removed. When the collets are out, the valve springs and top collar can be lifted out. Alternatively, a valve removal tool can be employed, and this is obtainable at any accessory shop, or from B.S.A. Motor Cycles Ltd., Spares Dept., Waverley Works, Birmingham, 10.

*Decarbonising.* Rotate the engine by means of the kickstarter until the pistons are at the top of their stroke, and scrape off the carbon deposit with an old penknife taking care not to damage the piston crowns.

All traces of carbon must be cleaned from the combustion chambers and the ports.

### **Examination of Valves.**

An examination of the seating on a valve will quickly reveal whether or not it requires regrinding. The same applies to the seating in the cylinder head, although this tends to deteriorate much more slowly than that on the valve, and it is seldom that a valve requires grinding-in merely in order to restore the cylinder head seating.

When the valves were ground-in originally, the seatings on the valve and in the cylinder head were smooth, and continuous, and of uniform width all round their circumferences. The probability is that even after very considerable mileages, the inlet valves will have suffered very little, and may indeed still be



smooth and continuous. If this is so, they can be restored to their original condition with a very slight amount of grinding, using fine-grade paste.

The exhaust valves, on the other hand, may require more attention. If the seatings are merely discoloured, a little attention with grinding paste will soon rectify them, and this is all that should be necessary if the engine has been properly looked after, and the valves are examined at reasonable intervals. If, however, the exhaust valves have become scaled or pitted a considerable amount of grinding-in may be necessary, and in extreme cases, this operation may fail to restore the seatings. A valve is not likely to deteriorate to this extent unless it has been abused by such things as continuous running without sufficient tappet clearance or with an incorrect mixture from the carburetter or late ignition timing. (See pages 22, 52 and 24 for these respective items), or it may be the result of neglect in failing to re-grind at reasonable intervals. If either of the exhaust valves is found to be in this condition, do not attempt to grind it in, but send it to B.S.A. Motor Cycles Ltd., Repair Dept., Waverley Works, Birmingham, 10 (local dealer, overseas), for re-facing. Similarly, if the seatings in the cylinder head are badly pitted, the head should be returned to the factory for the seats to be re-cut. The importance of having proper factory treatment in the event of excessive pitting or scaling is emphasized for any attempt to rectify these by the use of grinding paste alone will only result in the removal of too much metal from the seats in the head with consequent pocketing and its attendant adverse effect on performance.

### **Valve Grinding.**

Smear a small quantity of grinding compound (obtainable from any garage or accessory shop) over the face of the valve, and return the valve to its seat. Note that a light spring inserted under the valve head greatly facilitates the grinding-in operation, allowing the valve to lift and be rotated to a new

position periodically. Hold the valve stem with the special tool provided and rotate the valve backwards and forwards whilst maintaining a light pull. The valve should be raised and turned to a new position after every few strokes. Grinding should be continued until the valve seat and face show a uniformly matt metallic surface all round. Grinding paste is often supplied in two grades, coarse and fine. For valves in good condition a small amount of grinding with the fine grade should be sufficient. If the valves are in poor condition, however, but not bad enough to return to the factory, start with the coarse grade and finish off with the fine, being careful to remove all traces of the former before changing to the latter.

Thoroughly clean the valves, seatings and stems, and wipe out the ports before reassembly. It is a good idea also to smear the valve stems lightly with engine oil before inserting them in their guides.

#### **Valve Springs.**

After a considerable mileage it may be desirable to renew the valve springs, as these tend to lose their efficiency due to heat and other causes. This is more likely to occur in the case of the exhaust valve springs, as they are also more heavily loaded, and a useful test when the springs are dismantled is to compare them for height. Any spring which is found to be appreciably shorter than the others should be replaced. If the springs are examined in this manner while decarbonising, and replaced if necessary, it will save dismantling specially for this purpose at a later date.

#### **Valve Rockers.**

To remove the rockers from the rocker boxes, if this should be required for any reason, remove the acorn nuts on the rocker spindles, and tap the latter out, applying a soft punch to the threaded ends exposed when the nuts are removed, so as to avoid damaging the threads. Careful note should be kept of the rocker assembly for replacement, as the various washers must obviously be inserted in the correct order (see Fig. 29).

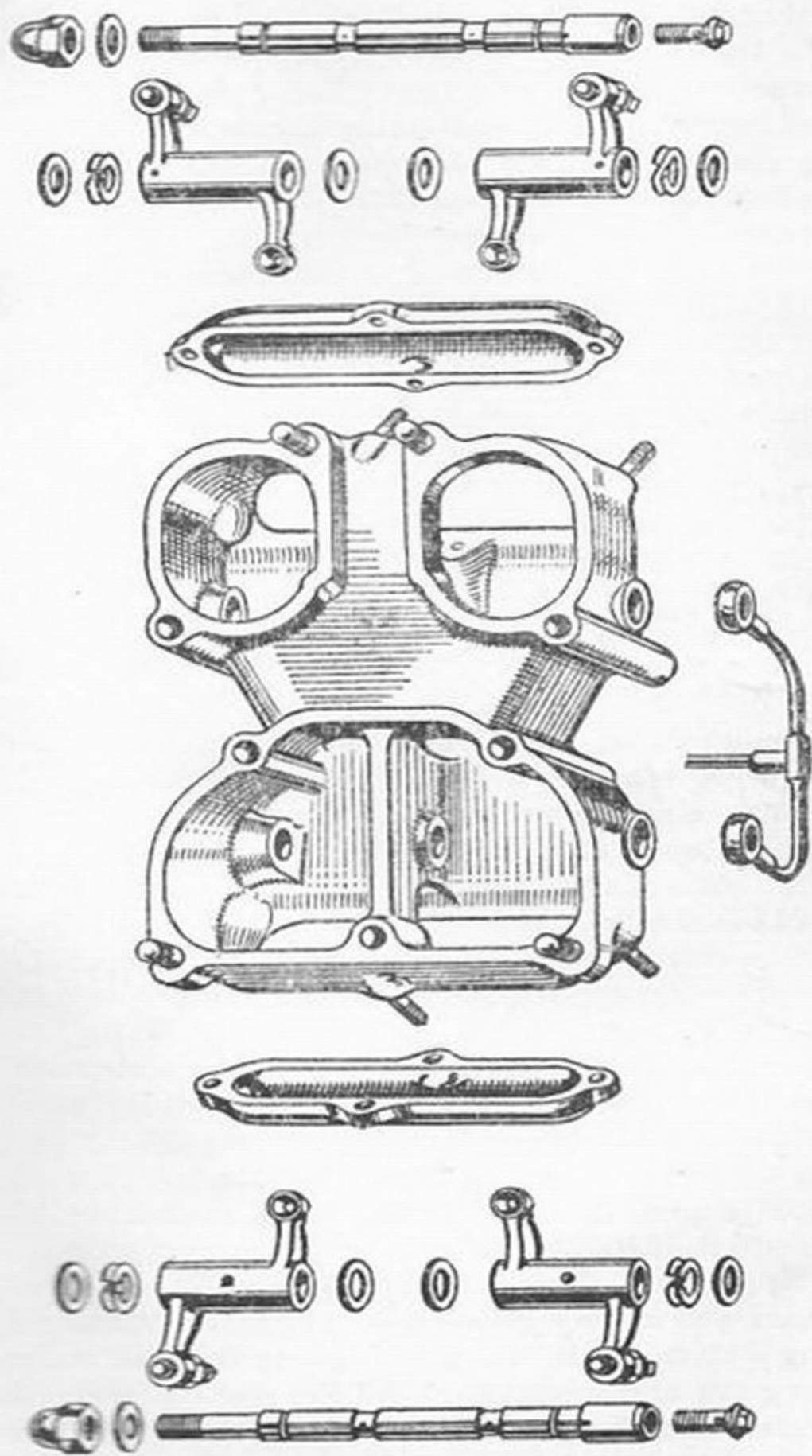

Fig. 29. Rocker Assembly.



## Cylinders and Pistons.

In the ordinary course of events it should rarely be necessary to remove the cylinder block, since top overhaul, already described usually suffices to keep the machine in first class working condition. In any case, this operation is difficult to carry out without the help of an assistant, and unless the condition of the engine indicates that the pistons, rings or cylinder bores require attention, the owner will be well advised not to disturb the cylinder block.

Symptoms indicating faulty piston rings might include heavy oil consumption, poor compression (but only if the valves are in good order; otherwise they are much more likely to be the cause) and excessive piston slap when warm. The latter might be due to worn bores, which could be checked without removing the block, if the pistons were moved to bottom dead centre, thus exposing the bores for examination and measurement.

In order to examine the cylinder and piston the parts should be dismantled in the following order:

*The cylinder block.* Rotate the engine until the pistons are at the bottom of their stroke, remove the cylinder base nuts (nine in all), and carefully lift the block upwards until the pistons are clear of the bores. It is as well to have an assistant to steady the pistons as they emerge from the block, to avoid possible damage. Scrape the paper washer off the cylinder base flange and/or crankcase face.

*Gudgeon pin circlips.* There is one at each end of the gudgeon pin, but it is only necessary to take out one per piston. Insert a pointed instrument such as a screwdriver or the tang of a file into the slot specially provided for the purpose and lever the circlip out of its groove.

*The gudgeon pins.* These are a tight fit in the pistons and it may be necessary to warm the latter, using a cloth which has been immersed in hot water, wrung out and wrapped round the piston. Support the piston on the side from which the circlip has been removed (to avoid strain on the connecting rod) and tap out the gudgeon pin from the opposite side

using a light hammer and a punch of suitable diameter.

*The pistons.* These will now be free and the inside of each should be marked to enable them to be replaced in the correct bore and the correct way round. All 'A' engines except Road Rocket are fitted with split skirt pistons and the diagonal cut **must** be at the front. Cover the crankcase mouth with a cloth to prevent foreign matter falling into the case.

*The piston rings.* If these are stuck in their grooves they must be prised free and removed from the piston. This needs care as the rings are brittle. All carbon deposit should be carefully scraped from the grooves and the inside edges of the rings. Any rings showing brown patches on the surface in contact with the cylinder should be replaced.

*Check the piston ring gap.* Insert each ring in turn into the cylinder followed by the piston. The latter is pushed against each ring to make sure it is true in the bore. Withdraw the piston and check the gap which should be .010 in. to .015 in. for the two upper rings, and .009 in. to .013 in. for the scraper ring.

Fit new rings if the gap greatly exceeds the figures stated. It is advisable to check the gap of new rings in a similar manner, before fitting, and if the gap is less than specified the ends of the ring should be carefully filed to the correct limit.

#### **Re-assembling the Head.**

Replace the valves into their respective ports, place the springs over the stems with the top collar in position, and with the head resting on wooden block as before, compress the springs until the split collets can be inserted. A dab of grease on the inside of the collets will serve to hold them in position until the spring is released. Make quite sure that the collets are correctly located.

#### **Re-assembling the Engine.**

Before assembly all components should be thoroughly washed in petrol and dried, and a supply of clean engine oil should be available. It is advis-

able to have a set of paper joint washers to hand, together with some jointing compound, and as previously mentioned, new cylinder head and rocker box gaskets, etc., should be obtained if considered necessary. Re-assembly should not present any difficulty if the following routine is observed.

*The pistons.* When the rings are refitted, warm the pistons and replace them on their connecting rods. Make sure they are on the same rods from which they were removed and that they are the right way round.

*The gudgeon pins.* Dip these in engine oil and tap into position while the pistons are still warm, supporting the piston from the opposite side.

*The gudgeon pin circlips.* These must not on any account be omitted.

*Cylinder base washer.* Fit a new paper washer to the crankcase face lightly smearing with jointing compound before doing so.

*The cylinder block.* Prepare two strips of hard wood,  $3/4$  in. square  $\times$  approx. 8 in. long, so that they can be laid across the crankcase mouth under the pistons (one in front and one behind). These will enable the pistons to be held square while the block is lowered. Coat the bores with engine oil and smear the pistons similarly. Turn the piston rings so that the gaps are on the opposite sides of the piston. It will simplify the fitting of the block if the piston rings are compressed into their grooves by means of piston ring compressors (obtainable from accessory suppliers) so that as soon as the pistons enter the bores, the clips will be automatically pushed off, when they, and the two wooden strips, can be moved away before the block is finally lowered into position.

*Cylinder head gasket.* This should be replaced if there is any suspicion that it has been 'blowing.' (See page 58).

*The cylinder head.* There are nine bolts, which must be tightened in the order shown in Fig. 10 to prevent risk of distortion.

Re-check the tightness of all these bolts and give



them a final wrench to make certain that they are really tight.

*The pushrods.* Insert these down the push rod apertures in the head and fit them into their respective tappet cups. The exhaust push rods are longer than the inlet rods.

*The rocker box.* Make sure that the push rods are correctly inserted into the rocker ends and tighten the box down. This must be done carefully to avoid straining the rocker box due to the action of the valve springs. There are five bolts, one of which is accessible through the rear tappet cover, and four nuts below the rocker box.

Note that the front fixing nuts are thinner so as to make room for the steady stays, washers, and nuts, which can be refitted as soon as the rocker box is finally bolted down.

*The tappet clearances.* A full description of how to check these clearances is given on page 22.

*The tappet covers.* A special spanner is provided in the tool kit to suit the nuts.

*Sparking plugs.* Clean and adjust as described on page 23, and replace. Connect the H.T. leads, **making sure that they are coupled to the correct plug.**

*The carburetter.* The needle and slide must be inserted correctly in position before the ring nut is screwed down. Fit the carburetter to the air cleaner connection before the carburetter itself is attached to the cylinder head.

*Rocker oil feed pipes, petrol tank, petrol pipes, exhaust system, etc.* When the tank on the A10 G.F. Plunger model is refitted make sure that the distance collars which are part of the rear mounting are in position inside, and the washers outside their respective 'ears' before tightening the nuts.

## GEARBOX

### Swinging Arm Models.

A separate gearbox is fitted to these models. The construction and operation of this and the foot gear change mechanism are similar to the instructions below and illustration. (Fig. 30).

### A10, G.F. Plunger Model.

The four-speed gearbox fitted to this model is of the constant-mesh sliding pinion type with internal dog engagement. The sliding pinions incorporating the gear engagement dogs are mounted one pair (*A* and *B*, Fig. 30) on the mainshaft, and one pair (*C* and *D*) on the layshaft, and each pair is operated by a separate sliding fork (*E* and *F*) specially designed to couple together the individual members of each pair. These forks slide on a common axis, provided by a horizontal rod *G*, and their respective motions, by which the various gear engagements are secured, are determined by the rotation of a cam plate *H* in which are machined two special cam grooves, one for each fork, and in which operating pegs *J* formed on the forks engage.

### Gear-change Mechanism.

The cam plate, which operates the sliding forks, is caused to rotate by the foot gear-change mechanism through the intermediary of a sleeve *K* to which the plate is fixed, and on which the double-acting ratchet teeth are formed. When the foot gear-change pedal *L* is raised or depressed the rocking lever *M* is rocked on its fulcrum (mounted in the gearbox partition which is not illustrated) by means of a ball-end *N* engaging in the slotted lever *O*, coupled to the pedal, and the spring-loaded ratchet pawl *P* at the other end of the rocking lever imparts the appropriate movement to the sleeve *K*.

### Dismantling.

This is a job which is only undertaken by the experienced owner as a rule, and one which in the ordinary course of events should never be necessary. Before carrying out this work the clutch must be

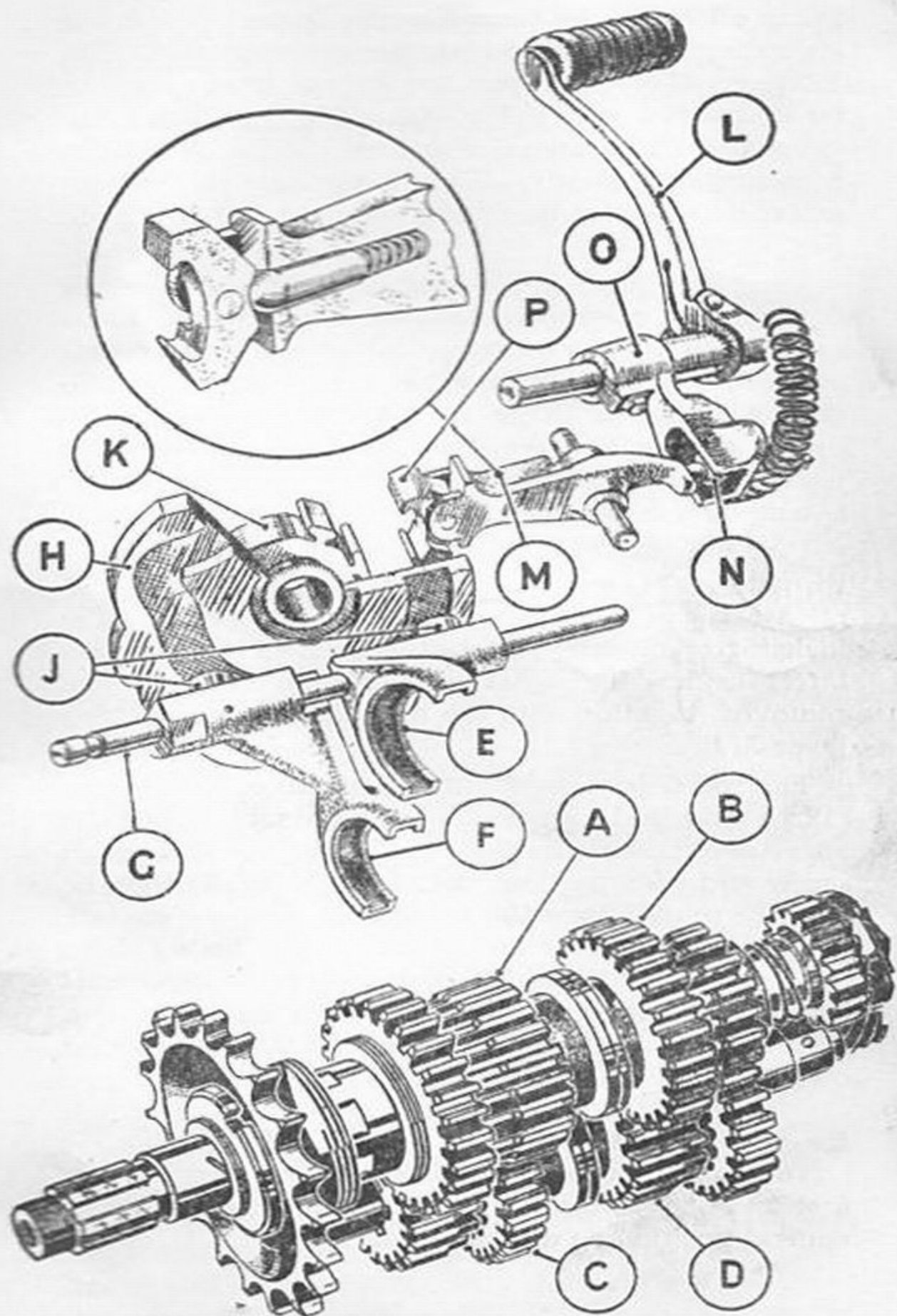

Fig. 30. Foot Gear Change and Gearbox  
(A10 G.F. Plunger model).



taken off bodily by removing the domed cap *A*, the six spring nuts *B*, and then the spring plate *C* (Fig. 19, page 39), whereupon the central fixing nut can be unscrewed and the clutch withdrawn from the splines on the gearbox mainshaft. (For clutch dismantling see below.) Then disconnect the speedometer drive under the outer cover at the front (*C*, Fig. 14, page 34).

Move the gears to the neutral position, and then remove the gearbox outer cover which will come away with the kickstarter and gear-change pedals and the clutch lever (first release the clutch cable) still in position. Note that as the cover is withdrawn the spring pressure on the kickstarter pedal is released. This point must be watched when re-assembling.

Pull out the clutch operating rod which passes through the centre of the mainshaft, and then release the nut on the mainshaft which holds the kickstarter ratchet pinion and spring, laying these latter aside. The gearbox partition can then be removed, together with the foot gear-change rocking lever *M*.

The rod *G* is pressed into the gearbox shell at the clutch end and secured by a grub screw which is accessible under the gearbox. Release this grub screw and then pull out the rod. It should then be possible to withdraw the entire gear cluster complete with shafts and the two sliding forks bodily from the gearbox, although, if preferred, the components may be withdrawn separately. This may call for a certain amount of manoeuvring, but the experienced owner will have no difficulty.

### **Re-assembly.**

This is carried out in precisely the reverse order first making certain that the cam plate is in the neutral position as described above.

## CLUTCH

### Swinging Arm Models.

The dry six plate clutch is similar in construction to the five plate type illustrated in Fig. 31 with the exception of the following items:

Single tooth chainwheel, six friction plates, lock-nuts for the adjusting nuts, not fitted with an end cover.

### A10, G.F. Plunger Model.

The clutch fitted to these machines is of the dry five-plate type.

### Dismantling.

If, after considerable mileage, it is found desirable to have new fabric inserts fitted, and the owner prefers to strip the clutch himself, this operation will be facilitated by reference to the illustration Fig. 31.

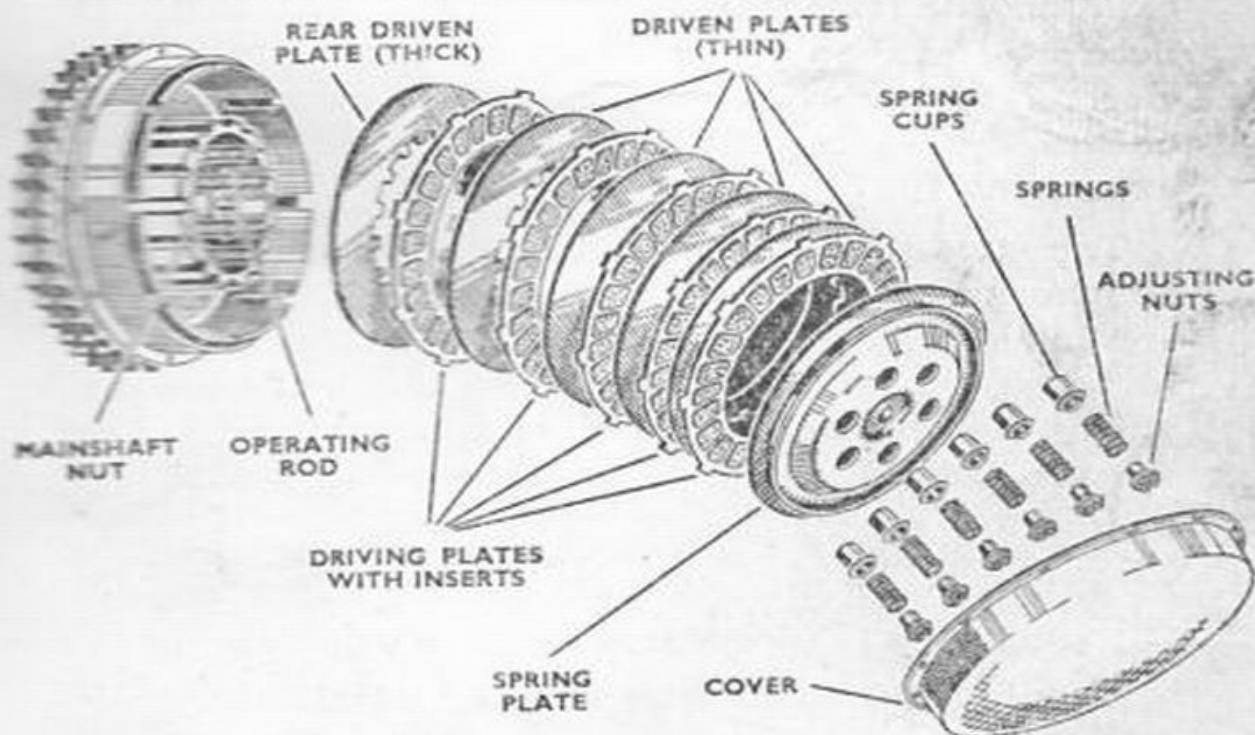

Fig. 31. Clutch (A10 G.F. Plunger model).

### Re-assembly.

Make sure that the plates are free from grease, and that they are refitted in the correct order.

The six adjusting nuts should be tightened evenly until the clutch 'bites' without slipping and is perfectly free when disengaged. It is advisable to have this final adjustment carried out by an experienced repairer.

**INSTRUCTIONS FOR THE MAINTENANCE  
OF LUCAS  
ELECTRICAL EQUIPMENT  
fitted to  
B.S.A. 'A' Group Cycles**

The electrical equipment is designed and manufactured to give long periods of service without any need for adjustment or cleaning. The small amount of attention which is required is described below and we advise riders to carry out the procedure outlined in order to ensure that the best service is obtained.

**BATTERY**

About once a month take off the battery lid, remove the filler plugs from each of the cells and examine the level of the electrolyte in each cell. If necessary, add sufficient distilled water to bring the electrolyte level with the top of the separators. Do not use tap water and do not use a naked light when examining the condition of the cells.

The condition of the battery should occasionally be checked by taking hydrometer readings of the specific gravity of the electrolyte. Readings should be taken after the motor cycle has been out for a run when the electrolyte is thoroughly mixed. The specific gravity readings and their indications are as follows:

|             |                                |
|-------------|--------------------------------|
| 1.280—1.300 | Battery fully charged.         |
| About 1.210 | Battery about half discharged. |
| Below 1.150 | Battery fully discharged.      |

The readings for each of the three cells should be approximately the same. If one cell gives a reading very different from the others it may be that electrolyte has been spilled or has leaked from this particular cell or there may be a short circuit between the plates. In this case the battery must be examined by a Lucas Service Depot or Agent.



Finally never leave the battery in a discharged condition for any length of time, wipe away all moisture and dirt from the top of the battery, and keep the terminals clean and smeared with petroleum jelly to prevent corrosion.

**Special Note.** The Positive terminal of the battery is earthed.

## DYNAMO

### Output Control.

The dynamo is of the compensated voltage control type and is arranged to work in conjunction with a regulator unit which is fitted alongside the cut-out. The regulator causes the dynamo to give an output which varies according to the load on the battery and its state of charge. The dynamo also gives an increase of output to balance the current taken by the lamps whenever they are switched on. It will be noted that during daytime running when the battery is in good condition the dynamo gives only a trickle charge so that ammeter readings will seldom be more than one or two amperes. A discharge reading may be observed immediately after switching on the headlamp, but after a short time the battery voltage will fall and the regulator will respond causing the dynamo output to balance the lamp load.

### Maintenance.

About every 10,000 miles take off the cover band and check the brushes and commutator. See that the brushes move freely in their holders by holding back the brush springs and pulling gently on the flexible connectors. If a brush is inclined to stick, remove it from its holder and clean its sides with a petrol moistened cloth. Be careful to replace brushes in their original positions in order to retain bedding.

The commutator should be clean, free from oil or dirt, and should have a polished appearance. If it is dirty, clean with a dry duster while the engine is slowly turned over. If the commutator is very dirty, moisten the cloth with petrol.

### **Lubrication.**

No lubrication is required to the dynamo as ball bearings are fitted to both the commutator and driving end bracket. These bearings are packed with grease during assembly and will last until the machine is in need of a complete overhaul.

## **MAGNETO**

### **Cleaning and Adjustment.**

About every 3,000 miles remove the contact breaker cover and examine the contact breaker. If the contacts are burned or blackened, clean them with fine carborundum stone or fine emery cloth and afterwards wipe away dust or dirt with a petrol moistened cloth. Check the contact breaker setting after cleaning.

To check the contact breaker setting, turn the engine until the contacts are fully opened and insert the gauge provided on the ignition spanner. If the setting is correct the gauge should be a sliding fit. If, however, the gap varies appreciably from the gauge, slacken the locknut on the fixed contact and turn the contact screw until the gap is set to the gauge. Finally tighten the locknut.

Next examine the pick-ups which can be removed when the fixing arms are moved aside. See that the brush in each pick-up moves freely and while the pick-ups are removed, clean the slip ring track and flanges with a soft dry cloth.

### **Lubrication.**

About every 3,000 miles take off the contact breaker cover. Turn the engine over until the small hole in the cam can be seen. This hole is fitted with a wick which enables the oil to reach the pad and cam face. In the case of the manual control fitted to the Shooting Star and Road Rocket where the cam ring is moveable, an additional pad is incorporated in the magneto housing. A few drops of thin machine oil will be adequate. *Take care that no oil gets on to the contacts.*

### **Renewing High Tension Cable.**

A high tension cable showing signs of cracking or perishing must be replaced by 7 m.m. rubber covered ignition cable. To make the connection to the pick-up terminal, thread the moulded terminal nut over the cable, bare the end of the cable for about 1/4 in., thread the wire through the washer removed from the original cable and bend back the wire strands. Screw the nut into its terminal.

### **Headlamp. LAMPS**

To gain access to the head and pilot bulbs, slacken the front rim retaining screw, situated at the top of the rim. Disengage and withdraw the front rim and light unit assembly, removing the upper edge first. To remove the main bulb press the moulded adaptor inwards and turn it to the left. Lift off the adaptor and withdraw the defective bulb.

When inserting a replacement bulb, locate the slot in the bulb flange with the projection in the bulb holder.

Refit the adaptor, engaging its moulded recesses with corresponding projections on the bulb holder. Press inwards and secure by turning the adaptor to the right. The pilot bulb holder is a push fit in the reflector. Refit the outer rim to the nacelle, locating the bottom of the rim first. After replacing, check the beam setting. With the Lucas prefocus type bulbs fitted in these lamps, the filament is correctly positioned during manufacture in relation to the focal point of the reflector. No further focusing is necessary.

### **Setting the beam.**

The best way of checking the setting of the lamp is to stand the motor cycle in front of a light coloured wall at a distance of about 25 feet. If necessary, slacken the bolts securing the headlamp and move the lamp until, with the main driving light switched on, the beam is projected straight ahead and parallel with the ground. With the lamp in this position, the height of the beam centre on the wall should be the same as the height of the centre of the headlamp from the ground.



### Stop Light Switch.

This is operated by the brake rod through a spring. It is desirable to see that any mud or grease is periodically cleared away from the switch and the operating mechanism should be oiled occasionally with thin oil.

### Rear Stop Lamp.

The red transparent plastic portion of the lamp can be taken off by removing the two retaining screws.

| Replacement Bulbs.           | Lucas No. | Watts        |
|------------------------------|-----------|--------------|
| Headlamp (main) ... ..       | 312       | 30/24        |
| Headlamp (pilot) ... ..      | 988       | 3            |
| Stop-tail lamp (when fitted) | 384       | 6/18 (index) |

## WIRING CONNECTIONS FOR B.S.A. HEADLAMP COWL

### Cowl.

When this is packed as a loose item (i.e., not installed in position on the front forks), it comprises an actual cowl unit, with three following items attached to it.

### The Main Switch.

This is on the left-hand side, and has seven terminals, or binding posts, on its underside numbered clockwise.

### Speedometer Head.

This has on its underside the connector for the speedometer light on the side adjacent to the main switch, the other items being the control for the speedometer trip and the actual drive. The latter passes through the headlamp shell.

### Ammeter.

This is on the right, and has on its underside two terminals, the one next to the speedometer head being the negative, and the other being the positive.

www.rpw.it

## HOW TO CONNECT

### Four Wires from the end of Harness.

Single purple wire with one eyelet connector near the end. The end is connected to main switch No. 3. The eyelet is connected to ammeter NEGATIVE.\*

Two brown wires† to ammeter POSITIVE\* connected by single eyelet.

Single maroon wire with one eyelet connector near the end. The end is connected to the speedometer light and the eyelet is connected to the main switch No. 5.

### Three Wires from the Headlamp.

Single red to main switch No. 4 with intermediate connector for easy removal.

Two black wires with connectors to either of the two black wires from the dip switch.

### Three Wires from the Dip Switch.

Two black wires connect to headlamp as indicated above. Single blue wire from centre of Dip Switch to main switch No. 2.

**Special Note.**—All these sets are POSITIVE EARTH. Check that the battery is connected in this manner.

*\*If the ammeter reads incorrectly, reverse the two connections.*

*†Only one brown wire is used on rigid and plunger frame models.*

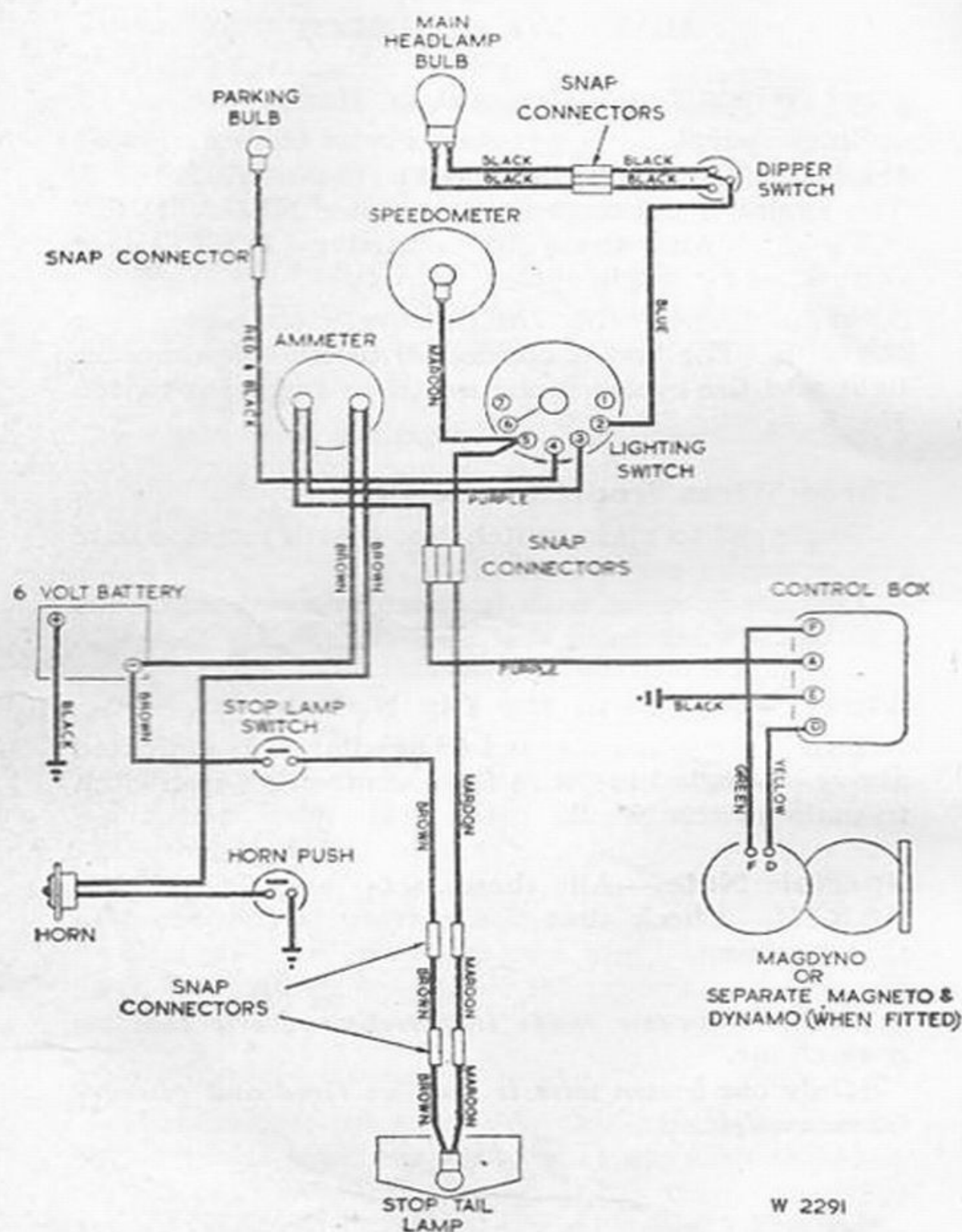

Fig. 32. Wiring Diagram (POSITIVE earth)  
 (A7. A7 Shooting Star and A10 G.F. Swinging  
 Arm model)



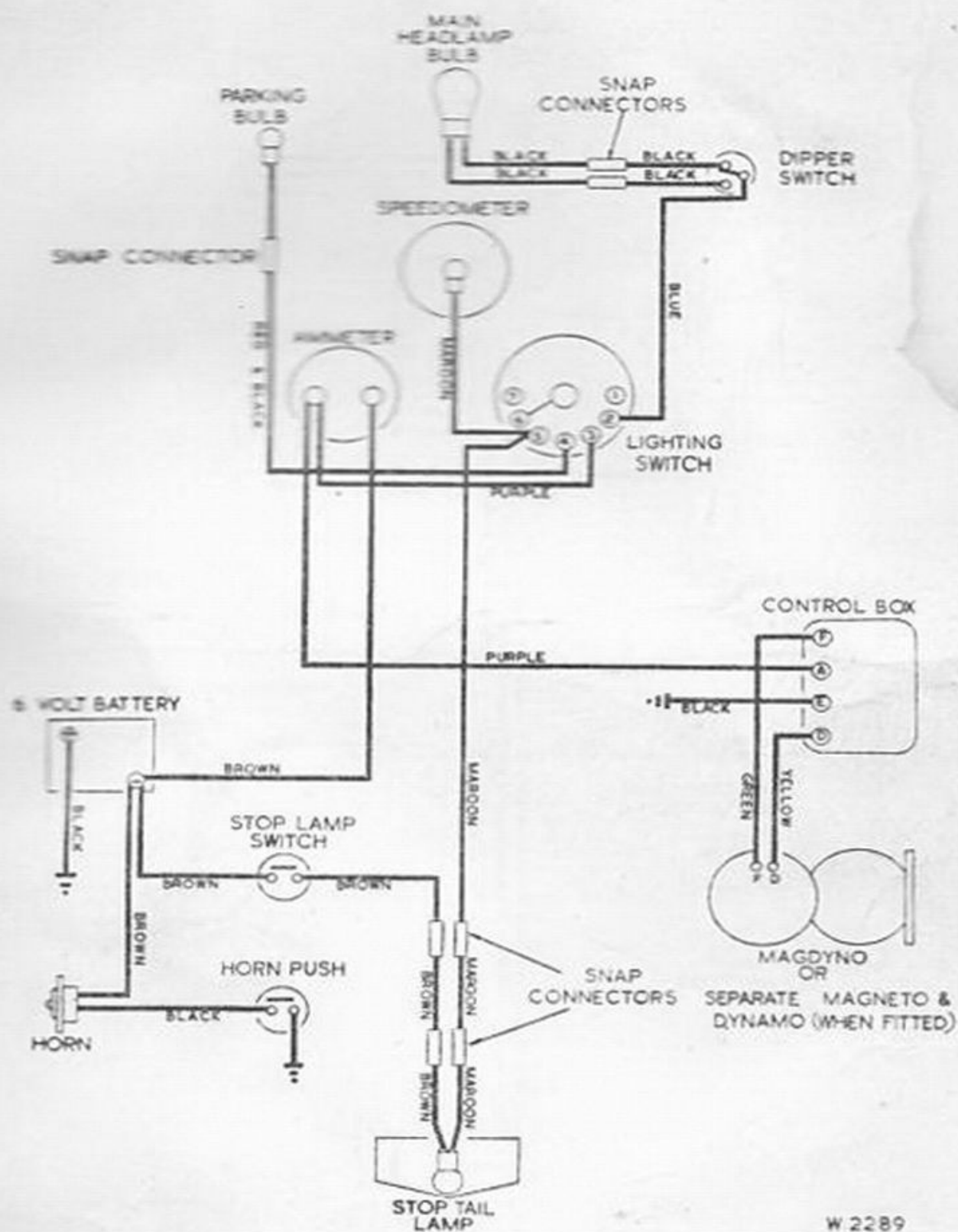

Fig. 33. Wiring Diagram (POSITIVE earth)  
(A10 G.F. Plunger model).

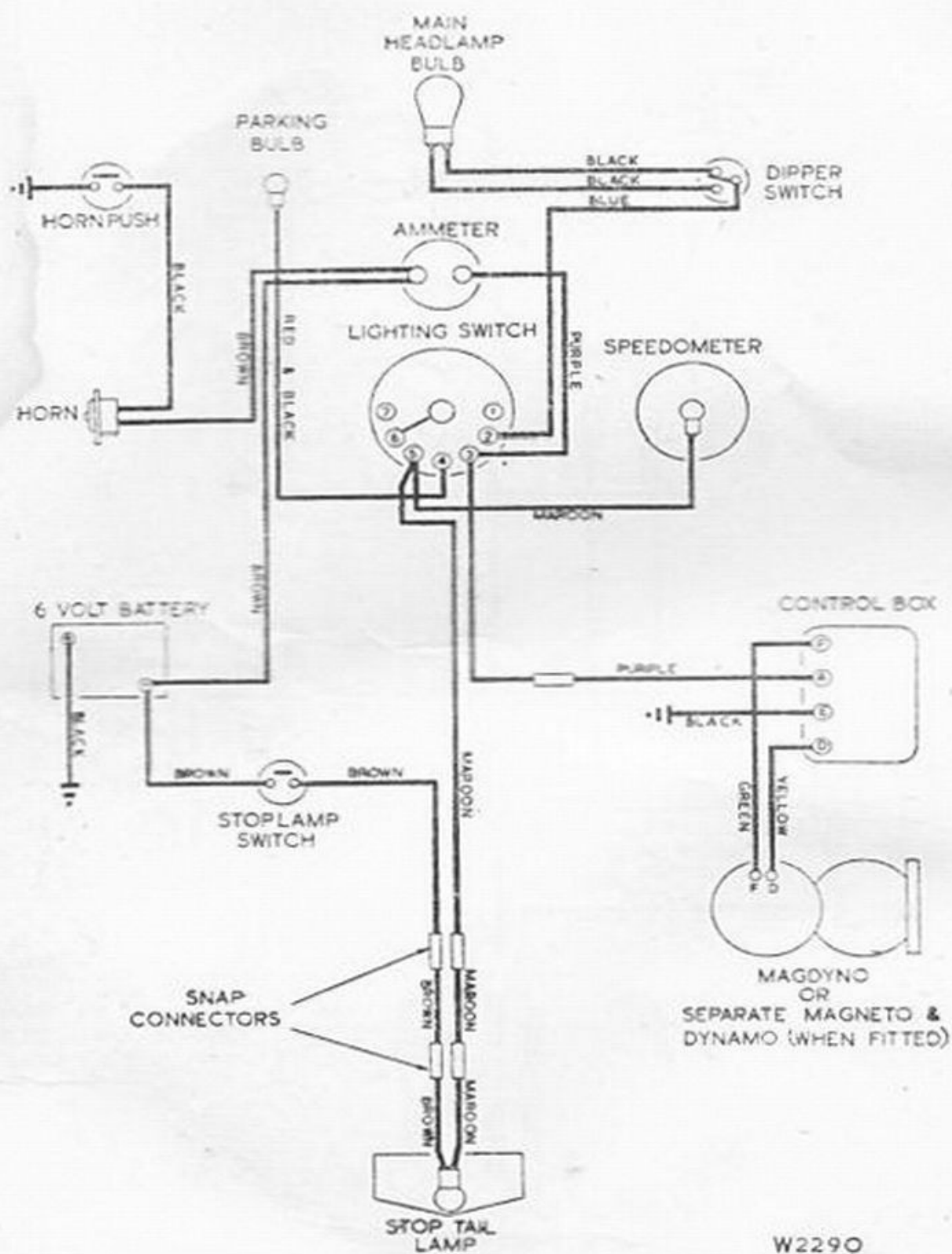

Fig. 34. Wiring Diagram (POSITIVE earth) (A10 Road Rocket).

# B.S.A. MOTOR CYCLE SPARES STOCKISTS



SAVE TIME AND POSTAGE BY CONTACTING YOUR NEAREST B.S.A. STOCKIST FOR B.S.A. SPARE PARTS, SPARE PART CATALOGUES, INSTRUCTION BOOKS, TRANSFERS, ETC.

ALL B.S.A. DEALERS CARRY STOCKS OF B.S.A. SPARE PARTS BUT THE FOLLOWING APPOINTED STOCKISTS MAINTAIN A COMPREHENSIVE RANGE.

| Town.       | Name of Stockist.               | Address.                                      | Telephone No.   | Telegraphic Address.         |
|-------------|---------------------------------|---|-----------------|------------------------------|
| Aberdeen    | J. Dawson                       | 24-26, Thistle Street                         | 25556           |                              |
|             | George Cheyne (Cycles).         | 147-149, Holburn St.                          | 50341/2         | Motobike, Aberdeen.          |
| Aberystwyth | Gwalia Motor Co.                | North Parade                                  | 525             |                              |
| Accrington  | Bill Snape Ltd.                 | 379, 392 and 396, Blackburn Road.             | 4724            |                              |
| Aldershot   | Phillips Bros. (Aldershot) Ltd. | Birchett Road                                 | 1111-2          | Phillips, Cycles, Aldershot. |
| Alton       | J. G. Robertson (Cycles) Ltd.   | 55-57, High Street                            | 193             |                              |
| Andover     | Corbett & Ellis (Andover) Ltd.  | Weyhill Road                                  | 2991            |                              |
| Ashington   | Mains of Ashington              | Laburnam Terrace                              | 3204            |                              |
| Aylesbury   | Eborn's Garage                  | 44, Walton Street, Aylesbury.                 | 3150            | Eborn's, Aylesbury.          |
| Banbury     | Trinder Bros.                   | 2a-4, Broad Street                            | 2546            |                              |
| Barnsley    | T. Garner & Son                 | Sheffield Road                                | 2866            |                              |
| Barnstaple  | Bob Ray Ltd.                    | 43, High Street                               | 4266            |                              |
| Bath        | R. U. Holoway & Son             | 32/34, St. Johns Road                         | Bathwick 5084   |                              |
| Bedford     | The Imperial Cycle Co.          | 58, St. Loyes                                 | 2374            |                              |
| Belfast     | W. J. Chambers & Co.            | 106 & 108, Donegall Pass.                     | 27253-4         | Fastnote, Belfast.           |
| Biggleswade | Bryants                         | 25, 27, 72 & 74, Shortmead Street.            | 3108            |                              |
| Birkenhead  | Bob Simister Ltd.               | 540-544, New Chester Rd., Rock Ferry.         | Rock Ferry 1452 |                              |
| Birmingham  | County Cycle & Motor Co. Ltd.   | 265-266, Broad St.                            | Midland 2671    |                              |
|             |                                 | 104, Bath Row (Repairs) (closed Sat. 1 p.m.). | Midland 2817    |                              |



## B.S.A. Motor Cycle Spares Stockists—continued.

| Town.                     | Name of Stockist.                           | Address.                           | Telephone No.      | Telegraphic Address.         |
|---------------------------|---|------------------------------------|--------------------|------------------------------|
| <b>Birmingham</b>         | .. C. E. Cope & Sons Ltd.                   | 481-487, Hagley Rd., Edgbaston 17. | Bearwood 2246-7    |                              |
| "                         | .. Shovelbottom's Ltd.                      | 376, Ladypool Road, Sparkbrook 12. | South 2212-3247    |                              |
| "                         | .. Aston Auto Motors                        | .. 173-177, Aston Rd. 6            | Aston Cross 3201-2 |                              |
| <b>Blackburn</b>          | .. S. & G. Motor Cycles (Blackburn) Ltd.    | 15-17, Great Bolton Street.        | 6678               |                              |
| <b>Blackpool</b>          | .. J. Hall & Son (Blackpool) Ltd.           | 102-6, Devonshire Road.            | 22130              |                              |
| <b>Blandford</b>          | .. Badger Garages Ltd.                      | Salisbury Road                     | .. 615             |                              |
| <b>Bolton</b>             | .. Charlie Robinson (Motor Cycles) Ltd.     | 119 & 121, Higher Bridge Street.   | 3931               |                              |
| <b>Boscombe</b>           | .. Graze Bros. Ltd.                         | .. 473 & 475, Christchurch Road.   | Boscombe 33231/2   |                              |
| <b>Bradford</b>           | .. Sidneys Motor Cycles                     | 107, Manningham Lane.              | 29689              |                              |
| "                         | .. J. K. Hirst Ltd.                         | .. 41, Wakefield Road              | 22543              |                              |
| <b>Bridgwater</b>         | .. Anderson & Wall Ltd.                     | 18, St. Mary Street                | 2416               | Anderson & Wall, Bridgwater  |
| <b>Brighton</b>           | .. Redhill Motors (Brighton) Ltd.           | 104, North Road                    | .. 25281           |                              |
| <b>Bristol</b>            | .. S. J. Fair Motors Ltd.                   | 201-3, Cheltenham Road.            | 4-6238/<br>4-1015  |                              |
| <b>Bromsgrove</b>         | .. Harold Tozer (Bromsgrove) Ltd.           | 110, Birmingham Rd.                | 3228               |                              |
| <b>Brynmawr</b>           | .. Jayne's Motors                           | .. Cwmbach Garage                  | .. Brynmawr 271    |                              |
| <b>Bury St. Edmunds</b>   | Barclay Motors Ltd.                         | Kings Road Corner                  | 2345/9             |                              |
| <b>Cambridge</b>          | .. King & Harper Ltd.                       | Milton Road Corner                 | 3201               | Motors, Cambridge.           |
| <b>Canterbury</b>         | .. Hallets of Canterbury                    | St. Dunstan's Street               | 3046               |                              |
| <b>Cardiff</b>            | .. Car Distributors (Cardiff) Ltd.          | 134-140, City Road                 | 30022              |                              |
| "                         | .. Robert Bevan & Son                       | 29-35, Castle Street               | 27477/8            |                              |
| <b>Carlisle</b>           | .. W. T. Tiffen & Son                       | Irishgate, Carlisle                | .. 25024           | Tiffen, Irishgate, Carlisle. |
| <b>Carmarthen</b>         | .. Eddie Stephens Motors.                   | 22/23, Water Street                | Carmarthen 6233    |                              |
| <b>Castleford</b>         | .. Barrett's Motors Cycle (Castleford) Ltd. | 27-35, Aire Street                 | .. 2983            |                              |
| <b>Chapel-en-le-Frith</b> | Eric W. Bowers                              | .. Town End                        | .. 144             |                              |
| <b>Chatham</b>            | .. Grays of Chatham Ltd.                    | 11-19, High Street                 | 4005               |                              |
| <b>Chelmsford</b>         | .. Hadlers Garage Ltd.                      | New Street                         | .. 4844-5          | Hadler, Chelmsford.          |
| <b>Cheltenham</b>         | .. Leslie Paynter                           | .. Bath Street                     | .. 2887            |                              |
| <b>Chester</b>            | .. Davies Bos. Ltd., (Chester).             | 34, Bridge Street                  | .. 25510           |                              |
| <b>Chichester</b>         | .. W. Goodridge & Co. Ltd.                  | East Street                        | .. 2033            |                              |

## B.S.A. Motor Cycle Spares Stockists—continued.

| Town.             | Name of Stockist.                      | Address.                               | Telephone No.     | Telegraphic Address.    |
|-------------------|--|--|-------------------|-------------------------|
| Clydebank         | .. John A. Weddell ..                  | 72/114, Dumbarton Road.                | Clydebank 1429    |                         |
| Colchester        | .. G.B.R. Motors Ltd.                  | 1-2, East Hill                         | .. 6131/2         |                         |
| Calne             | .. C. H. Schofield (Motors) Ltd.       | Market Place                           | .. 859            |                         |
| Coventry          | .. Coventry Motor Mart Ltd.            | 86, London Road                        | .. 2146-7         | Coventry Motor Mart.    |
| Crewe             | .. Cooke's Garage                      | 10-20, Nantwich Rd.                    | 2011              | Cooke's Motors, Crewe.  |
| Croydon           | .. Godfrey Ltd.                        | 228-234, London Rd.                    | Croydon 3641-2    | Gofrabike, Croydon.     |
| Dagenham          | .. Reginald Smith (Motor Cycles) Ltd.  | Imperial House, New Road.              | Rainham 3284-2786 |                         |
| Dalton-in-Furness | H. Holme ..                            | 24-26, Ulverston Rd.                   | 25                |                         |
| Darlington        | .. The Duplex Motor & Cycle Co. Ltd.   | 10-16, Grange Road                     | Darlington 2071   | Duplex, Darlington.     |
|                   | .. White Bros. (Darlington) Ltd.       | 201/205-9, Northgate                   | 67757             |                         |
| Dartford          | .. Schwieso Bros. Ltd.                 | 177, Lowfield Street                   | Dartford 4279     |                         |
| Derby             | .. Ingles Provincial Garages Ltd.      | Walbrook Road                          | .. 45289          |                         |
| Doncaster         | .. W. Cusworth (Doncaster) Ltd.        | 7 Hall Gate..                          | .. 4594           |                         |
| Douglas           | L.O.M. Gilbert Harding Ltd.            | 18, Duke Street & 5, Market Street.    | Douglas 170       |                         |
| Dudley            | .. Chas. E. Cope & Sons Ltd.           | 98 & 193, High St.                     | Dudley 3464-5-6   |                         |
| Dundee            | .. George McLean Ltd.                  | Ward Road                              | .. 5087           | Vehicles, Dundee.       |
| Dunstable         | .. B. G. England (Dunstable) Ltd.      | Half Moon Hill, London Road.           | 843-4             |                         |
| Eastbourne        | .. Jempsons Ltd.                       | 118-120, Seaside                       | .. 756            | Jempsons, Eastbourne.   |
| Edinburgh         | .. J. R. Alexander & Co. Ltd.          | 10-14, Lothian Road                    | 4455              | Motorcycles, Edinburgh. |
| Elgin             | .. Farquharsons                        | 55-57, High Street                     | 7188              | Elgin 7188.             |
| Enfield           | .. D. J. Shepherd & Co. (Enfield) Ltd. | 434-6, Hertford Road Enfield Highway.  | Howard 1631       |                         |
| Exeter            | .. P. Pike & Co. Ltd.                  | Alphington Street                      | .. 58241          | Piko, Exeter.           |
| Frome             | .. J. Difazio Motor Cycles.            | 25, Catherine Street                   | 2913              |                         |
| Gateshead         | 8 .. O. Carmichael & Son Ltd.          | 71, 75, 79, 83 & 87, High West Street. | 71815             |                         |
| Glasgow           | C3 .. Bell Bros. (H.P.) Ltd.           | 223, St. Georges Rd.                   | Douglas 6414      | Douglas 6414, Glasgow.  |
|                   | C4 .. J. R. Alexander & Co. Ltd.       | 240-286, Great Western Road.           | Douglas 7516      | Alex Moto, Glasgow.     |
| Gloucester        | .. Harpers of Gloucester               | 23a, Worcester Street                  | 23187             | Gloucester 23187.       |
| Grimsby           | .. H. J. Gresswell & Son Ltd.          | 13, 15 & 19, Osborne Street.           | 2202              |                         |

## B.S.A. Motor Cycle Spares Stockists—continued.

| Town.         | Name of Stockist.                     | Address.                                   | Telephone No.              | Telegraphic Address.            |
|---------------|---------------------------------------|--|----------------------------|---------------------------------|
| Guernsey      | .. Millard & Co. Ltd.                 | .. Victoria Road                           | .. 777                     | Millard Motors Guernsey.        |
| Guildford     | .. E. Pascall (Guildford) Ltd.        | 11-12, Woodbridge Road,                    | Guildford 2274-5-6         |                                 |
| Harrogate     | .. H. Aclam (Prop. H. Baynes).        | 11, Bower Road                             | .. 5125                    |                                 |
| Harrow ..     | .. Pinks of Harrow                    | .. Station Road                            | .. 0044-5, Spares 3328     | Pink. Harrow,                   |
| Hatfield      | .. W. Waters & Sons Ltd.              | 32, Great North Rd.                        | 2255                       |                                 |
| Hereford      | .. A. Kear & Co.                      | .. 52, Commercial St.                      | 2239                       | Kear, Hereford.                 |
| Holbeach      | .. Gordon Woodman Ltd.                | 34, Fleet Street                           | .. 3221                    |                                 |
| Hornchurch    | .. T. W. Kirby Ltd.                   | .. 10, Reneo Corner                        | .. 8785                    |                                 |
| Hounslow      | .. Stanley's Motors                   | .. 46-8, Lampton Road                      | Hounslow 1949              | Stanley's, Hounslow.            |
| Huddersfield  | .. Earnshaw Ltd.                      | .. Manchester Road                         | .. 1232                    |                                 |
| Hull ..       | .. Browns (Witham) Ltd.               | .. 47-49, Witham                           | .. 29802                   |                                 |
| .. ..         | .. Jordans of Hull                    | .. Storey Street                           | .. 16131                   | Gumpton, Hull.                  |
| Ilford ..     | .. J. J. Double (Motor Cycles) Ltd.   | 1, 2, 3 & 4, Mildmay Parade, Cranbrook Rd. | Valentine 0191, 0192, 7723 |                                 |
| Ilkeston ..   | .. Ray Gamble                         | .. Pelham Street (off Bath Street).        | 873                        |                                 |
| Ipswich ..    | .. Revetts Ltd.                       | .. Clarkson Street                         | .. 3726/7                  |                                 |
| Jersey ..     | .. Colebrooks (J. D. Poingdestre).    | 22½ New St. Johns Road, St. Helier.        | Central 642                | Colebrooks, Jersey.             |
| Keighley      | .. Dick Ratcliffe                     | .. Coldshaw Garage, Haworth.               | Haworth 3133               |                                 |
| Kendal ..     | .. Tom O'Loughlin Ltd.                | 66, Stricklandgate                         | .. 315                     |                                 |
| Kirkcaldy     | .. County Motors (Kirkcaldy) Ltd.     | Junction Road                              | .. Dysart 5631             |                                 |
| Lancaster     | .. Pye Motors Ltd.                    | .. Parliament Street                       | .. 3553                    |                                 |
| Launceston    | .. J. Wooldridge & Son                | Western Road                               | .. 21                      | Wooldridge, Launceston.         |
| Leeds, 1      | .. Watson-Cairns & Co. Ltd.           | 157-8, Lower Briggate.                     | 33024/5                    | Watson-Cairns, Briggate, Leeds. |
| Leicester     | .. E. W. Champion & Son Ltd.          | Wellford Place                             | .. 58054                   |                                 |
| Lincoln ..    | .. Wests (Lincoln) Ltd.               | 116, High Street                           | .. 21262                   |                                 |
| Liverpool, 7  | .. Bee Cycle & Motor Co. Ltd.         | 17-19, Renshaw St.                         | Royal 6375-6               | Bee Cycles, Liverpool.          |
| .. 3          | .. Cundles (Liverpool) Ltd.           | 41, Byrom Street                           | .. Central 4148            | Cundles, Central 4148.          |
| Llwhaden      | .. James Bowen & Sons (Llwhaden) Ltd. | Llwhaden, near Narberth, Pem.              | Llwhaden 6                 |                                 |
| London, N.W.1 | J. Grose Ltd.                         | .. 379-381, Euston Rd.                     | Euston 5231                |                                 |
| .. W.1        | .. Godfreys Ltd.                      | .. 208-210, Great Portland Street.         | Euston 4632-4              | Godfrabike, London.             |

www.bpw.it



## B.S.A. Motor Cycle Spares Stockists—continued

| Town.                  | Name of Stockist.                       | Address.                                      | Telephone No.          | Telegraphic Address.           |
|------------------------|---|---|------------------------|--------------------------------|
| London, S.E.18         | Clare & Co. Ltd.                        | 1, Woolwich High St.                          | Woolwich<br>0174       |                                |
| W.5                    | Kays of Ealing Ltd.                     | 8-10, Bond Street                             | Ealing<br>2387         | Sparexokay,<br>Ealux, London.  |
| S.E.13                 | F. Parks & Son Ltd.                     | 404, High Street,<br>Lewisham.                | Lee Green<br>0535      |                                |
| E.8                    | Eleanor Motors                          | 265-7-9, Mare Street,<br>Hackney.             | Amherst<br>5134-3923   |                                |
| E.7                    | Godfrey Ltd.                            | 418, Romford Road,<br>Forest Gate.            | Grange-<br>wood 1234-5 | Gofrabike,<br>Forgate.         |
| E.6                    | Godfrey Ltd.                            | 220, Barking Road,<br>East Ham.               | Grange-<br>wood 8088   | Gofrabike,<br>Forgate.         |
|                        | Glanfield Lawrence<br>(Highbury) Ltd.   | 28-32, Highbury<br>Corner.                    | North<br>2791          |                                |
| N.12                   | George Grose Ltd.                       | 834, High Road,<br>Finchley.                  | Hillside<br>2149       |                                |
| N.12                   | Glanfield Lawrence<br>Ltd.              | 407, High Road,<br>Finchley.                  | Finchley<br>0091       | Glanfn,<br>Norphone, London    |
| N.15                   | Godfreys Ltd.                           | 94, 96 & 104, High<br>Rd., Tottenham.         | STA<br>9960            | Gofrabike,<br>London.          |
| S.E.11                 | Writers Ltd.                            | 161-5, Kennington<br>Lane.                    | Reliance<br>1362       |                                |
| S.W.11                 | Owen Bros.                              | 19, Battersea Rise,<br>Clapham Junction.      | Battersea<br>7816      |                                |
| S.W.6                  | Claude Rye Ltd.                         | 897-921, Fulham Rd.,<br>Fulham.               | Renown<br>6174         | Ryebikes,<br>Walgreen, London. |
| S.W.9                  | Pride & Clarke Ltd.                     | 158, Stockwell Road                           | Brixton<br>6251        | Priclarke,<br>London.          |
| W.12                   | Turners Stores                          | 81-83, Goldhawk Rd.,<br>Shepherd's Bush.      | Sh. Bush<br>2436       |                                |
| W.3                    | Whitbys of Acton Ltd.                   | 273, The Vale, Acton                          | Sh. Bush<br>5355-6     |                                |
| S.E.15                 | West End Motors Ltd.                    | 171, High Street,<br>Peckham.                 | Newcross<br>2589       |                                |
| N.W.10                 | Slocombes Ltd.                          | 251-253, 269 & 271,<br>Neasden Lane, Neasden. | Gladstone<br>3355      |                                |
| S.W.17                 | Elite Motors (Tooting<br>Ltd.).         | 951-961, Garratt Lane,<br>Tooting Broadway.   | Balham<br>1200         | Elitemota, Toot<br>London.     |
| Lewestoft              | R. Wright                               | 67-69, London Road<br>South.                  | 645                    |                                |
| Macclesfield           | A. Watling                              | 49, Buxton Road                               | 3592                   |                                |
| Maidstone              | Redhill Motors (Maid-<br>stone) Ltd.    | The Broadway,<br>Maidstone.                   | 3096                   |                                |
| Manchester, 3          | Tom Davies (Motors)<br>Ltd.             | 233, Deansgate                                | Blackfriars<br>0681    |                                |
| 22                     | Alex Parker                             | 31/33, Palatine Road,<br>Northden.            | Wythen-<br>shaw 2062   |                                |
|                        | Fred Fearley Ltd.                       | 692-4, Ashton Old<br>Road.                    | East<br>1445-6         | Fernbike,<br>Manchester        |
| Mansfield              | Henstocks                               | 128, Chesterfield Rd.                         | 329                    | Henstock 329<br>Mansfield.     |
| Middlesbrough          | J. T. Dickinson<br>(Middlesbrough) Ltd. | 160-162, Lindthorpe<br>Road.                  | 3861                   | Payacob,<br>Middlesbrough      |
| Neath                  | Fred Rist                               | 16 & 17, Windsor Rd.                          | Neath<br>780           |                                |
| Newcastle-on-<br>Tyne. | Dene (Newcastle)<br>Motor Co. Ltd.      | Haymarket                                     | 2-9165/6               | Ened, Newcastle-<br>on-Tyne.   |

## B.S.A. Motor Cycle Spares Stockists—continued.

| Town.           | Name of Stockist.                       | Address.                                  | Telephone No.  | Telegraphic Address.    |
|-----------------|---|---|--|-------------------------|
| Newport, (Mon.) | R. J. Ware & Sons ..                    | 69, Commercial St.                        | 66206  |                         |
| Norwich         | .. Chapmans (Norwich) Ltd.              | 38-42, Duke Street                        | 24727  |                         |
| Nottingham      | .. E. W. Campion & Son Ltd.             | Arkwright Street and Queens Road.         | 83444  |                         |
| Oswestry        | .. Roy Evans (Motor Cycles).            | Willow Street ..                          | 1144-7   |                         |
| Oxford ..       | .. Temples ..                           | .. 69, St. Thomas St.                     | 2485   |                         |
| .. ..           | .. Faulkner & Son ..                    | .. 12, Cardigan Street                    | 57279  |                         |
| .. ..           | .. John Avery ..                        | .. 228/230 & 240, Banbury Road.           | 57362/3  |                         |
| Parkstone       | .. Bob Foster ..                        | .. 472-6, Ashley Road                     | 3500   |                         |
| Perth ..        | .. M. Shaw & Sons ..                    | .. 143 High Street ..                     | 483  |                         |
| Peterborough    | .. Barrows Bros. ..                     | .. 55-57, Westgate ..                     | 2154   |                         |
| Plymouth        | .. P. Pike & Co. Ltd. ..                | .. Millbay Road ..                        | .. Plymouth Piko, Plymouth.<br>63108                     |                         |
| Pontardulais    | .. T. Griffiths ..                      | .. Forest Gate ..                         | .. Pontardulais 323                                      |                         |
| Portsmouth      | .. Jenkins & Purser Ltd.                | 277-281, Copnor Rd.                       | 2339   |                         |
| ..              | .. Glanfield Lawrence                   | 147-157, Fratton Rd.                      | 74331  |                         |
| ..              | .. Percy Kiln Ltd. ..                   | .. 65-67, Elm Grove ..                    | 4793   |                         |
| Preston ..      | .. Loxhams Garages Ltd.                 | Central Garage, Charnley St., Fishergate. | Sales Dept. Loxhams, 4242 Preston.<br>Service Dept. 4243 |                         |
| Pulborough      | .. Gray & Rowsell (Bury Ltd).           | Bury Gate, Pulborough.                    | Bury 4   |                         |
| Radcliffe       | .. Will Lord (Motor Cycles) Ltd.        | 115, Blackburn St.                        | 2002   |                         |
| Reading         | .. Phillips & Bloomfield Motors Ltd.    | 10-24, South Street                       | 2635   |                         |
| ..              | .. Stocker & Shepherd Ltd.              | 129/133, Oxford Road                      | 2212-3983  |                         |
| Redhill ..      | .. The Redhill Motor & Cycle Works Ltd. | 50-54, Brighton Road                      | 327  |                         |
| Rotherham       | .. Ernest Cross ..                      | .. 55-59, Drummond Street.                | Rotherham 3987   |                         |
| Salisbury       | .. Pankhurst (Weymouth) Ltd.            | 78-79, Exeter Street                      | Salisbury 5222-3   |                         |
| Scarborough     | .. E. Andrew of Scarborough Ltd.        | 149, Victoria Road                        | Scarborough 1857   |                         |
| Sevenoaks       | .. Angus Motor Cycles                   | Station Parade ..                         | 3338   |                         |
| Sheffield, 1    | .. Walter Wragg Ltd.                    | Stanley Works, Wellington Street.         | 26098  | 26098 Sheffield.        |
| Shrewsbury      | .. J. R. Meredith ..                    | .. Coleham Head ..                        | 6529   |                         |
| Sittingbourne   | .. Scoones Garage ..                    | .. 9, West Street ..                      | 66   | Scoones, Sittingbourne. |

## B.S.A. Motor Cycle Spares Stockists—*continued.*

| Town.                 | Name of Stockist.                      | Address.                                  | Telephone No.             | Telegraphic Address.             |
|-----------------------|--|---|---------------------------|----------------------------------|
| Slough ..             | Sid Moram ..                           | Wexham Corner,<br>High Street.            | Slough<br>23767           |                                  |
| Southampton ..        | Alec Bennett Ltd. ..                   | 152, Portswood Road                       | 54081-2-3                 |                                  |
| Southport ..          | H. F. Brockbank ..                     | 62, King Street ..                        | 5054                      |                                  |
| St. Helens ..         | Geoff. Duke Ltd. ..                    | Greenfield Road<br>Garage                 | 3918                      |                                  |
| St. Ives ..           | Hallens (Hunts.) Ltd.                  | 8/10, The Broadway                        | St. Ives<br>3071          | Hallens, St. Ives                |
| Stockport ..          | Theobald & Coppack                     | 6, Chestergate ..                         | 2843                      | Theobald<br>Coppack, Stockport.  |
| Stoke-on-Trent        | J. & N. Bassett ..                     | Howards Place,<br>Shelton.                | 2890                      |                                  |
| Stourbridge ..        | Pearsons Cycle Depot                   | 31, Market Street ..                      | 5677                      |                                  |
| Sunderland ..         | Dunns Garage (Sun-<br>derland) Ltd.    | Wheatsheaf Corner,<br>North Bridge St.    | 57666/7                   |                                  |
| Swansea ..            | Glanfield Lawrence<br>(Swansea) Ltd.   | Rutland Street ..                         | 50311                     |                                  |
| Swindon ..            | Easters of Swindon ..                  | 73-75, Cricklade Rd.                      | 4196                      |                                  |
| Taunton ..            | W. P. Edwards<br>(Motors) Ltd.         | Station Road ..                           | 2943                      | Edwards, Motor<br>Cycle, Taunton |
| Thames Ditton         | Comerfords Ltd. ..                     | Portsmouth Road,<br>Thames Ditton.        | Emberbrook<br>5531        |                                  |
| Torquay ..            | P. H. Sharam Ltd. ..                   | 244-6, Union Street                       | 4184 &<br>7255            |                                  |
| Torquay ..            | Cooper Bros. ..                        | 117-129, Templehill                       | 925                       |                                  |
| Torquay ..            | W. H. Collins & Son                    | Kenwyn Mews ..                            | Turo<br>2168              |                                  |
| Tunbridge Wells       | G. E. Tunbridge ..                     | 21, London Road ..                        | 416                       | Motors,<br>Tunbridge Wells       |
| Twickenham ..         | Blays of Twickenham<br>Ltd.            | 192-9, Heath Road                         | Popesgrove<br>2103 & 1435 |                                  |
| Uxbridge ..           | Miles Motors ..                        | 60, High Street ..                        | Uxbridge<br>6000          |                                  |
| Walsfield ..          | Parkinsons (Wake-<br>field) Ltd.       | 38-52, Ings Road ..                       | 2087                      |                                  |
| Walsall ..            | The Motor Cycle<br>Mart (Walsall) Ltd. | 12, Ablewell Street                       | 3363                      |                                  |
| Warrington ..         | Jack Frodsham Ltd.                     | 37a, Winnick Street                       | 34713                     |                                  |
| Watford ..            | Lloyd Cooper & Co.<br>Ltd.             | 61, Queen's Road ..                       | 2125                      | Lloyd Cooper,<br>Watford.        |
| Westhill-on-<br>Sea   | J. Costin & Sons ..                    | 233-241, London Rd.                       | Southend<br>42215         |                                  |
| Weston-super-<br>Mare | Wyverns of Weston<br>Ltd.              | 3, Locking Road ..                        | 524                       | Wyverns,<br>Weston-super-Mare.   |
| Weybridge ..          | W. L. Lewis & Sons                     | 51, Church Street ..                      | 2210                      |                                  |
| Weymouth ..           | Tilley's (Dorset) Ltd.                 | 9, Frederick Place,<br>St. Thomas Street. | 72                        |                                  |
| Widnes ..             | Mark Taylor ..                         | 21, King's Street ..                      | 252                       |                                  |
| Wolverhampton         | C. E. Cope & Sons<br>Ltd.              | 169, Stafford Street                      | 24605-6                   |                                  |



## B.S.A. Motor Cycle Spares Stockists—continued.

| Town.            | Name of Stockist.                 | Address.                       | Telephone No. | Telegraphic Address               |
|------------------|-----------------------------------|--------------------------------|---------------|-----------------------------------|
| <b>Worcester</b> | W. J. Bladder & Son               | 52, Sidbury                    | 2438          | Bladder,<br>Sidbury, Worcester    |
| <b>Worksop</b>   | Etra Sugden Ltd.                  | 109, Gateford Road             | 3053          |                                   |
| <b>Worthing</b>  | Gray & Rowsell<br>(Worthing) Ltd. | 56, Broadwater Street<br>West. | 1224          |                                   |
| <b>Yeovil</b>    | The Yeovil Motor<br>Mart.         | Hendford                       | 267           | Motor Mart,<br>Yeovil.            |
| <b>York</b>      | C. S. Russell (York)<br>Ltd.      | Lawrence Street                | 23793         | Russell, Law-<br>rence St., York. |

Always use  
GENUINE

 **BSA**

SPARES



**B.S.A. MOTOR CYCLES LTD.,  
BIRMINGHAM, 11**

*Telephones: Birmingham VICTORIA 2381*

*Telegrams and Cables: "SELMOTO" Birmingham*

**SERVICE, SPARES and REPAIRS DEPARTMENT  
WAVERLEY WORKS, BIRMINGHAM 10**

*Telephones: Birmingham VICTORIA 3711*

*Telegrams and Cables: "SELSERV" Birmingham*

*B.S.A. Motor Cycles Ltd. reserve the right to alter the designs or  
any constructional details of their manufactures at any time  
without giving notice.*

Copyright B.S.A. Co. Ltd.,

Reprinted Aug. 1959 Printed in England Mc. 654-10 B.S.A.