



## AMZ Message Board Archives

[September 98](#)
[October 98](#)
[November 98](#)
[December 98](#)
[January 99](#)  
[February 99](#)
[March 99](#)
[April 99](#)
[May 99](#)
[April 00](#)
[May 00](#)

You'll find a wealth of information in this collection of old forum postings, including some interesting history of the Shaka III, Mini-Booster and Mini-Tubes. It's well worth browsing these old messages for the questions (and answers), tips and ideas that have been previously discussed.

### AMZ Op-Amp Noise Calculator

Enter the values into the form below and hit submit to calculate the total opamp noise.

<input type="text"/>	nV/root Hz Equivalent Input Noise Voltage
<input type="text"/>	pA/root Hz Equivalent Input Noise Current
<input type="text"/>	ohms, Non-inverting resistance
<input type="text"/>	ohms, Inverting resistance
<input type="button" value="Submit"/>	<input type="button" value="Reset"/>

The Equivalent Input Noise and Current values are found on almost every op-amp datasheet. Be sure to check that the specifications are in the proper units of measure. For instance, the Input Current is sometimes listed in fA instead of pA (1000 fA = 1 pA).

The source impedance  $R_s$  is the impedance (or reactance) of the device that is driving the op-amp input. It may be a guitar pickup, microphone, tube output or another op-amp. With the non-inverting op-amp, the Source impedance will be added to any input resistance  $R_3$  and used as the non-inverting resistance ( $R_4$  is not used). The  $R_1$  value will be the inverting input resistance value and  $R_2$  not used.

With an inverting opamp, the value of the source impedance is added to the value of the input resistor  $R_1$ . Usually there is no resistor on the non-inverting input as shown in the drawing, but if there is one, then the value should be entered. Once again, ignore  $R_2$ .

This is the simplified version of the calculations and parallel resistances and capacitor reactances have been eliminated for simplicity so the results may be compared to those in the table below. The calculations are based on 75°F (about 24°C) but the temperature does not make much difference unless it is extremely different from the nominal.

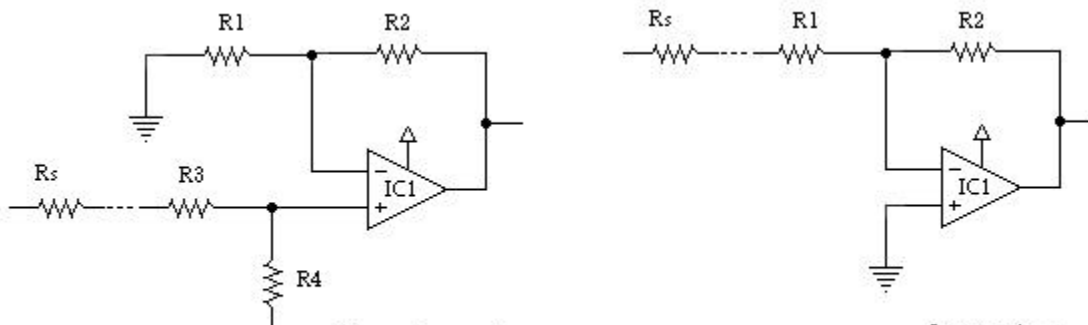

I have calculated the total input noise of a large selection of op-amps to serve as a general selection table for different circuits when driven by some common signal sources. One thing that is immediately noticeable is that chips that work well for microphone amplifiers do not give the same low noise performance when driven by a guitar pickup or piezo transducer. All of the measurements are for 1k Hz, which is commonly used in specifications.

A 150 ohm interface is common for microphone amplifiers, a 5k pickup would be a single coil and a 12k pickup would be a typical humbucker. Piezo pickups are basically capacitive but we can calculate the reactance of one at 1k Hz and use that as the basis for the noise table.

The numbers in the table are not meant to be 100% exact however they will be correct relative to each other for purposes of selecting an op-amp for use in a design. Lower noise numbers are quieter; high slew rates will indicate a wider bandwidth. Noise specs at 1k Hz were used.

Two commonly used chips stand out as being poor performers, the LM324 and the TL062, while the common TL072 gives good results across the board.

Noise figures for comparative purposes only:

<b>Total Calculated Noise, nV</b>					
	150ohm Mic	5k Pickup	12k Pickup	Piezo Pickup	Slew Rate V/ $\mu$ S
<b>SSM2017</b>	2.98	13.6	27.9	1064.1	17
<b>TL072</b>	18.1	20.6	23.2	95.1	13
<b>MC33178</b>	7.8	12.5	16.5	122.8	2
<b>MC33272</b>	18.1	20.7	23.9	281.5	10
<b>LF353</b>	25.1	26.9	28.9	96.6	13
<b>OP275</b>	6.4	13.9	24.0	800.5	22
<b>RC4560</b>	7.3	12.3	16.9	231.7	1.6
<b>LM833</b>	5.0	11.2	16.4	281.0	7
<b>OP227</b>	3.3	10.4	15.6	231.6	2.8
<b>LT1028</b>	2.4	11.2	18.9	538.1	15
<b>LT1007</b>	3.3	10.4	15.6	231.6	2.5
<b>TLC2272</b>	9.3	13.4	17.1	93.7	3.6
<b>RC4559</b>	10.2	14.3	18.7	281.1	2
<b>NE5532</b>	5.5	11.7	17.6	382.6	9
<b>AD711</b>	18.1	20.6	23.2	95.1	16
<b>AD797</b>	2.4	14.3	28.2	1064.1	20
<b>INA103</b>	2.5	14.3	28.2	1064.1	15
<b>OPA2111</b>	8.3	12.7	16.6	93.7	2

<b>OPA2227</b>	3.7	10.6	15.7	231.6	2.3
<b>OPA2604</b>	11.2	14.8	18.3	94.0	25
<b>OPA27</b>	3.9	10.6	15.7	231.6	1.9
<b>OPA270</b>	3.9	10.6	15.7	231.6	3
<b>LM318</b>	23.1	25.2	27.9	281.9	70
<b>LT1028</b>	2.4	11.2	18.9	538.1	30
<b>LT1115</b>	2.4	11.7	20.6	642.8	20
<b>SSM2275</b>	8.3	13.5	19.9	486.1	12
<b>LM324</b>	23.1	25.2	27.9	281.9	0.25
<b>TL052</b>	18.1	20.6	23.2	95.1	18
<b>TL062</b>	42.1	43.5	46.1	539.8	3.5

©2000 Jack Orman - May not be reproduced without permission.



Copr. 1995-2001 by Jack A. Orman  
All Rights Reserved

This page last modified on Friday, 13-Jul-2001 03:03:40 GMT

[AMZ Main Page](#)