

WORKING WITH OTA'S

How to use operational transconductance amplifiers in your designs and projects.

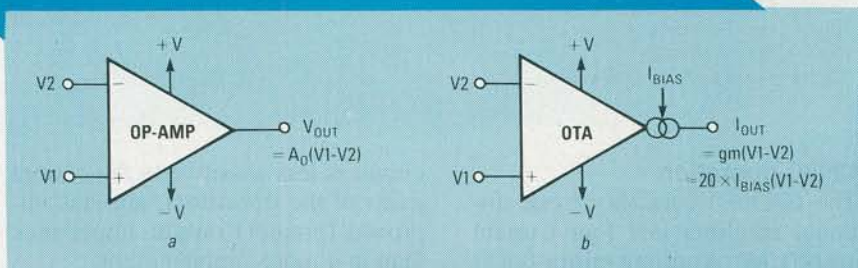

FIG. 1—A CONVENTIONAL OP-AMP (a) is a fixed-gain voltage-amplifying device, whereas an OTA (b) is a variable-gain voltage-to-current amplifier.

RAY MARSTON

THERE ARE MANY DIFFERENT TYPES OF OPERATIONAL amplifiers in use today, but an Operational Transconductance Amplifier, or OTA, is one that you may not be familiar with. This month we'll introduce you to the CA3080 OTA.

Op-amps and OTA's

Conventional op-amps are essentially voltage-amplifying devices. As figure 1-a shows, a conventional op-amp has differential input terminals and produces an output voltage of $A_O \times (V1 - V2)$, where A_O is the open-loop voltage gain (that gain is typically 100,000), $V1$ is the signal voltage at the non-inverting input, and $V2$ is the signal voltage at the inverting input. Also, a conventional op-amp has a fixed open-loop voltage gain, a high input impedance, and a low output impedance.

Like a standard op-amp, an OTA has differential input terminals, but, as shown in figure 1-b it is a voltage-to-current amplifier, as indicated by the constant-current symbol at its output. The input voltages produce an output in the form of a high-impedance current with a value of $g_m \times (V1 - V2)$, where g_m is the transconductance in mhos, or the *voltage-to-current gain* of the device. The transconductance is directly proportional to an external bias current (I_{BIAS}) fed into the amplifier's bias input. In an OTA, that current can be

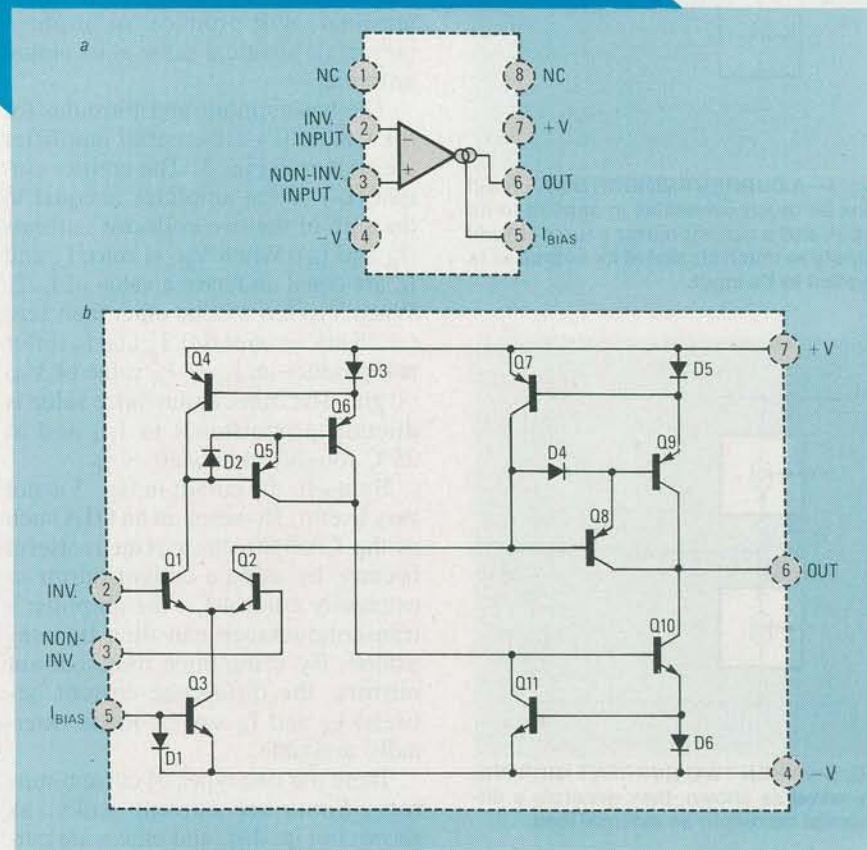

Fig. 2—THE PIN CONNECTIONS of the 8-pin dip version of the CA3080 are shown in (a), and the internal circuitry is shown in (b).

varied from 0.1 μA to 1 mA, providing a 10,000:1 gain-control range.

An OTA can be made to operate like a conventional voltage-amplifying op-amp by connecting a suitable load resistance to its output terminal so that its output current is converted to a proportional voltage. The total current consumed by an OTA is double the value of I_{BIAS} , which may be as low as 0.1 μA . That means that the device can be used in true micropower

applications. The amount of I_{BIAS} can be controlled easily using an external voltage and a series resistor. An OTA can be used as a Voltage-Controlled Amplifier (VCA), Voltage Controlled Oscillator (VCO), or Voltage Controlled Filter (VCF).

One of the best known OTA's is the CA3080. Figure 2-a shows its pin connections, and Fig. 2-b shows its internal circuitry. Table 1 lists the basic parameters of the device.

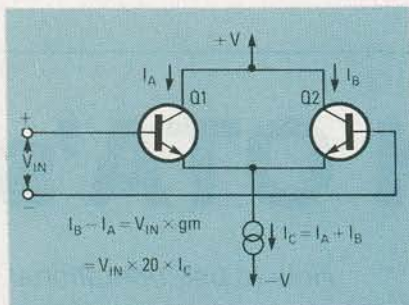

FIG. 3—A DIFFERENTIAL AMPLIFIER is at the heart of the CA3080.

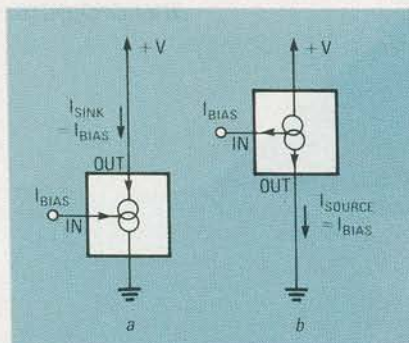

Fig. 4—A CURRENT-MIRROR SINK (a) will sink as much current as is applied to its input, and a current-mirror source (b) will supply as much current at its output, as is applied to its input.

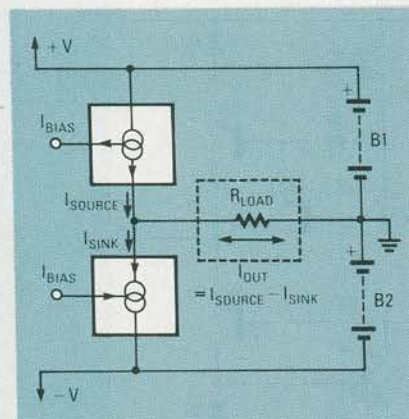

FIG. 5—WHEN TWO CURRENT MIRRORS are wired as shown, they generate a differential current in an external load.

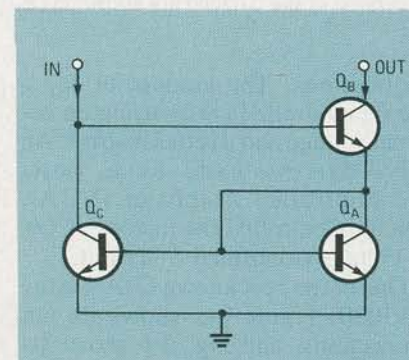

FIG. 6—A SINK-TYPE CURRENT MIRROR is made up of the circuitry shown here.

TABLE 1

CHARACTERISTIC	LIMITS
Supply Voltage Range	+4V to +30V DC or ±2V to ±15V
Max Differential Input Voltage	±15V
Power Dissipation	125 mW MAX
Input Signal Current	1 mA MAX
Amplifier Bias Current	2 mA MAX
Output Short-Circuit Duration	INDEFINITE
Forward Transconductance, gm	9600 μmho typ
Open Loop Bandwidth	2 MHz
Unity-Gain Slew Rate	50 V/μs
Common-Mode Rejection Ratio	110 dB typ

CA3080 operation

The CA3080 consists of one differential amplifier and four Current Mirrors (CM). A current mirror is a 3-terminal circuit that, when an external bias current is provided at its input terminal, will produce an in-phase current of identical value at its output terminal.

The basic circuit and formulas for the CA3080's differential amplifier are shown in Fig. 3. The emitter current (I_C) of the amplifier is equal to the sum of the two collector currents (I_A and I_B). When V_{IN} is zero, I_A and I_B are equal and have a value of $I_C/2$. When V_{IN} has a value other than zero (± 25 mV maximum), I_A and I_B differ and produce an $I_B - I_A$ value of $V_{IN} \times g_m$. The transconductance value is directly proportional to I_C , and at 25°C roughly equals $20 \times I_C$.

By itself, the circuit in Fig. 3 is not very useful. However, in an OTA such as the CA3080, the circuit is useful because by using a current mirror to externally control I_C , the amplifier's transconductance can then be controlled. By using three more current mirrors, the difference current between I_A and I_B can be made externally available.

There are two types of current mirrors. Some are current sinks, as shown in Fig. 4-a, and others are current sources, as shown in Fig. 4-b. When a current mirror source and current mirror sink are connected as shown in Fig. 5, and powered from a bi-polar power supply, they generate a differential current ($I_{SOURCE} - I_{SINK}$) in any load that is connected between the junction point and the circuit ground.

Figure 6 shows the actual circuit of a sinking-type current mirror. Transistor Q_A , which operates like a diode, is wired across the base-emitter junction of a second, closely-matched transistor. The mirror accuracy of that

circuit is less sensitive to the current gains of the transistors, and has improved (greater) output impedance than in a more-simple circuit.

Figure 7 shows how the differential amplifier and four current mirrors are connected in the CA3080 to make a practical OTA. Bias current (I_{BIAS}) controls the emitter current, and thus the transconductance of the Q1/Q2 differential amplifier via current-mirror C. The collector current of Q1 is mirrored by current-mirror A and fed to the bias terminal of current-mirror D, and the collector current of Q2 is mirrored by current-mirror B and fed to the sink terminal of current-mirror D, so that the externally available output current is equal to $I_B - I_A$.

If you refer back to Fig. 2-b, you will notice that Q1 and Q2 form the differential amplifier, D1 and Q3 make up current-mirror C, and current-mirror D is comprised of D6, Q10, and Q11. Current-mirror A (Q4-Q6, D2, and D3), and current-mirror B (Q7-Q9, D4, and D5) are slightly more complex than the others, using Darlington pairs of transistors and speed-up diodes to improve their performance.

Some finer points

All of the major operating parameters of the CA3080 are adjustable and depend on the value of I_{BIAS} . The maximum output current is equal to I_{BIAS} , and the total operating current of the IC is double the I_{BIAS} value. The input bias currents drawn by pins 2 and 3 when the IC is operating in the linear mode are each equal to approximately $I_{BIAS}/200$, with the actual values depending on the current gains of Q1 and Q2 within the chip.

The transconductance (Fig. 8-a) and the input and output impedances (Fig. 8-b) vary with I_{BIAS} . Figure 8 shows typical parameter values when the IC is driven from a bi-polar 15-volt

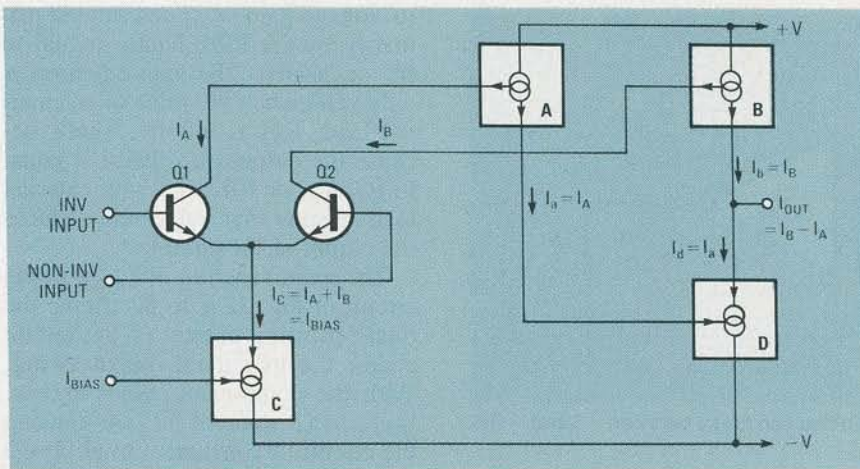

FIG. 7—THE CA3080 IS COMPRISED OF ONE DIFFERENTIAL AMPLIFIER AND FOUR CURRENT MIRRORS.

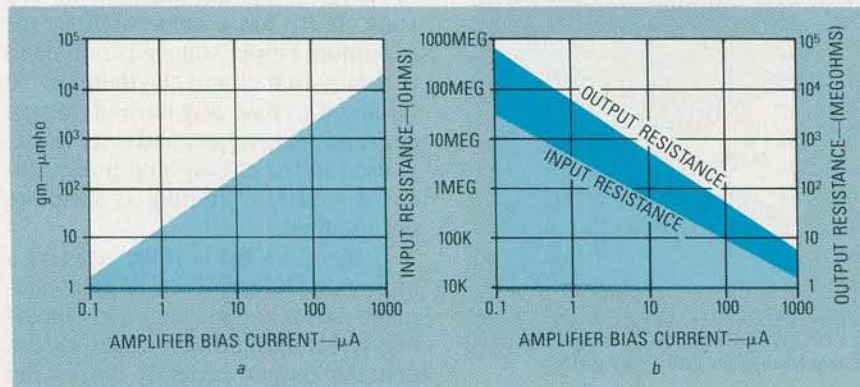

FIG. 8—THE TRANSCONDUCTANCE (a) and the input and output resistances (b) of the CA3080 vary with the bias current.

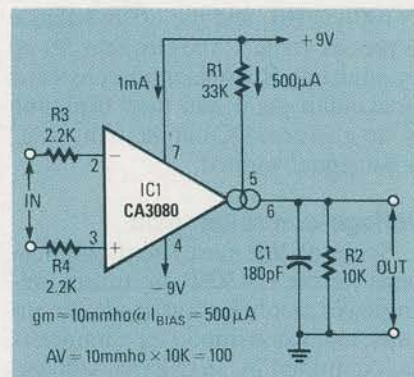

FIG. 9—THIS DIFFERENTIAL AMPLIFIER HAS 40-dB VOLTAGE GAIN.

supply at an ambient temperature of 25°C. Therefore, at a bias current of 10 μA , g_m is typically 200 μmho , with an input resistance of 800K and an output resistance of 700 megohms. At 1-mA bias current, those values change to 20 mmho, 15K, and 7 megohms respectively.

The output voltage of the IC depends on the values of I_{BIAS} and an external load resistor connected to the output (pin 6) of the device. If the

load impedance is infinite, the output can swing to within 1.5 volts of the positive supply and within 0.5 volt of the negative supply. If the impedance is not infinite, the peak output swing is limited to $I_{BIAS} \times R_L$. Thus at a 10- μA bias with a 100K load, the output swing is 1 volt.

The slew rate and bandwidth of the IC depend on the value of I_{BIAS} and any external loading capacitor connected to pin 6. The slew-rate value,

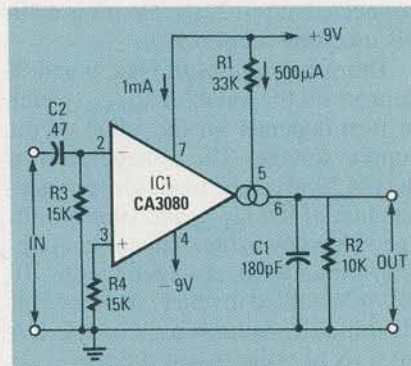

FIG. 10—AN AC-COUPLED 40-dB INVERTING AMPLIFIER.

in $\text{V}/\mu\text{s}$, equals I_{BIAS}/C_L , where C_L is the loading capacitance value in pF, and I_{BIAS} is in μA . With no external loading capacitor connected, the maximum slew rate of the CA3080 is about 50V/ μs .

Basic circuits

The CA3080 is very easy to use. Its I_{BIAS} terminal (pin 5) is internally connected to the negative supply (pin 4) by a base-emitter junction, so the biased voltage of the terminal is about 600 mV above that of pin 4. I_{BIAS} can be obtained by connecting pin 5 to either the ground line or the positive supply via a current-limiting resistor of suitable value.

Figures 9 and 10 show two ways of using the CA3080 as a linear amplifier with a voltage gain of about 40 dB. The circuit in Fig. 9 is a direct-coupled differential amplifier, and Fig. 10 shows an AC-coupled inverting amplifier. Both designs operate from bi-polar 9-volt supplies, so 17.4 volts is generated across bias-resistor R1, which feeds about 500 μA into pin 5 causing each IC to draw another 1 mA from their supply.

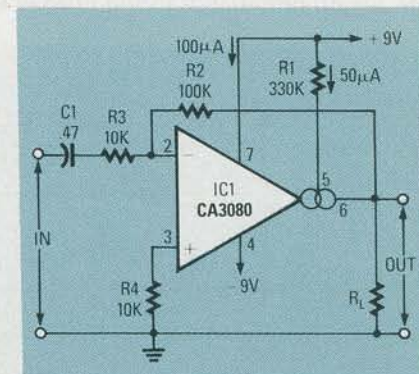

FIG. 11—THIS 20-dB MICRO-POWER INVERTING AMPLIFIER CONSUMES VERY LITTLE POWER.

At a bias current of 500 μA , the transconductance of the CA3080 is approximately 10 mmho. The outputs of Figs. 9 and 10 are loaded by a 10K resistor (R2), and therefore provide an overall voltage gain of 10 mmho \times 10K = 100, or 40 dB. The peak current that can flow into the 10K load is 500 μA (equal to I_{BIAS}), so the peak output is 5 volts. The output is also loaded by a 180-pF capacitor (C1), giving the circuit a slew-rate limit of 500 $\mu\text{A}/180\text{pF} = 2.8\text{V}/\mu\text{s}$. The output impedance of each circuit equals the R2 value of 10K. Note that in those two circuits the IC is used in the

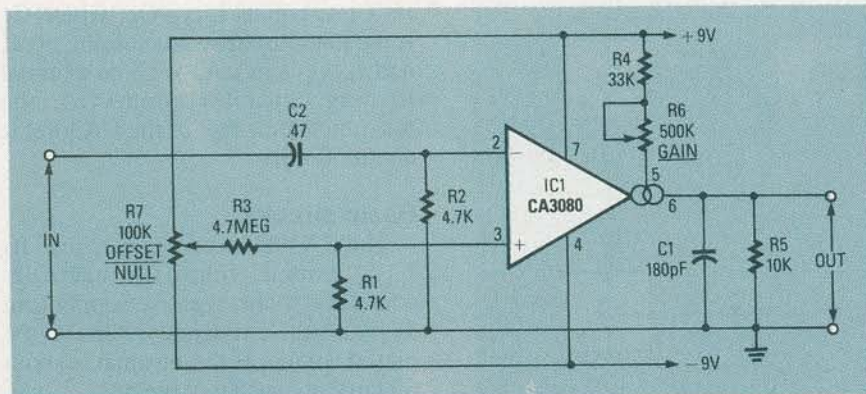

FIG. 12—A VARIABLE-GAIN AC amplifier has a gain that can range between $\times 5$ and $\times 100$.

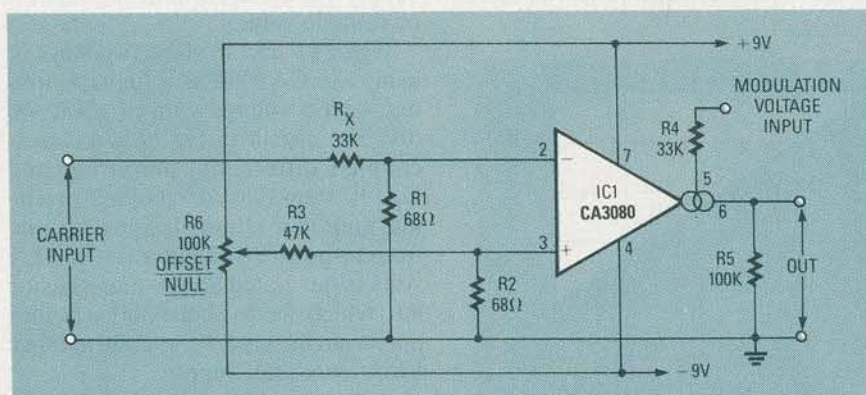

FIG. 13—AN AMPLITUDE MODULATOR or 2-quadrant multiplier has unity gain.

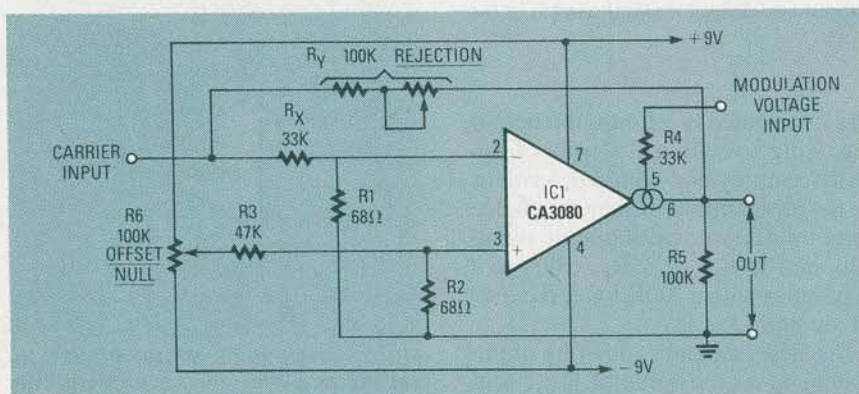

FIG. 14—BOTH PHASE AND AMPLITUDE can be controlled by the modulation signal in this ring modulator or 4-quadrant multiplier.

open-loop mode, and that if the slew rate is not externally limited by C1, the IC will operate at its maximum bandwidth and slew rate. Under those conditions the CA3080 may be excessively noisy.

In the circuit in Fig. 9, the differential inputs are applied via series resistors R3 and R4, which help equalize the source impedances of the two signals and maintain the DC balance of the IC. The circuit in Fig. 10 has both inputs tied to ground via 15K resistors and the input signal applied to one terminal only. With the input

connected to pin 2, the circuit is a 40-dB inverting amplifier.

The voltage gains in Figs. 9 and 10 depend on the value of I_{BIAS} , which in turn depends on the value of the supply voltage. The voltage gain of the CA3080 can be made almost independent of the I_{BIAS} and supply-voltage values by using conventional op-amp techniques, as shown by the 20-dB AC-coupled inverter circuit of Fig. 11, which consumes a mere 150 μ A from its bi-polar 9-volt supply.

The circuit in Fig. 11 is wired like a conventional inverting amplifier, with

its voltage gain (A_V) determined primarily by the R2/R3 ratio (equal to 10, or 20-dB). The gain equation is only valid when the value of an external load, R_L , is infinite. That's because the output impedance is equal to $R2/A_V$, or 10K, and any external load lessens that value and reduces the output of the circuit.

The main function of I_{BIAS} in the circuit of Fig. 11 is to determine the total operating current of the circuit and/or the maximum output swing. With the component values shown, I_{BIAS} has a value of 50 μ A, causing the circuit to consume a total of 150 μ A. When R_L is infinite, the output is loaded only by R2, which has a value of 100K, so the maximum output is 5 volts. If R_L has a value of 10K, the maximum output voltage is limited to 0.5 volt. That circuit can therefore be designed to have any desired voltage gain and peak output, and since the IC is used in the closed-loop mode, external slew-rate limiting is therefore not required.

If the CA3080 is to be used as a high-gain DC amplifier, or as a wide-range variable-gain amplifier, input-bias levels must be balanced to ensure that the output correctly tracks the input signals at all values of I_{BIAS} . Figure 12 shows how to bias an inverting AC amplifier in which the voltage gain is variable from roughly $\times 5$ to $\times 100$ via R6, and the offset balance is pre-set via R7. The circuit is set up by adjusting R6 to its minimum value (maximum gain) and then trimming R7 to give zero DC output with no AC input signal applied.

Voltage-controlled gain

Some of the most useful applications for the CA3080 are in true micropower amplifier and oscillator circuits, and when important parameters are controlled by an external voltage. In the latter category, one major application is as a VCA or amplitude modulator, in which a carrier signal is fed to the input of the amplifier, and the output amplitude is controlled or modulated by another signal fed to the I_{BIAS} terminal. Figure 13 shows a practical version of such a circuit.

The circuit in Fig. 13 is a variable-gain inverting amplifier. Input-bias resistors R1 and R2 have low values to minimize the noise levels of the IC and eliminate the need for external slew-rate limiting. Offset biasing is applied to the non-inverting input via

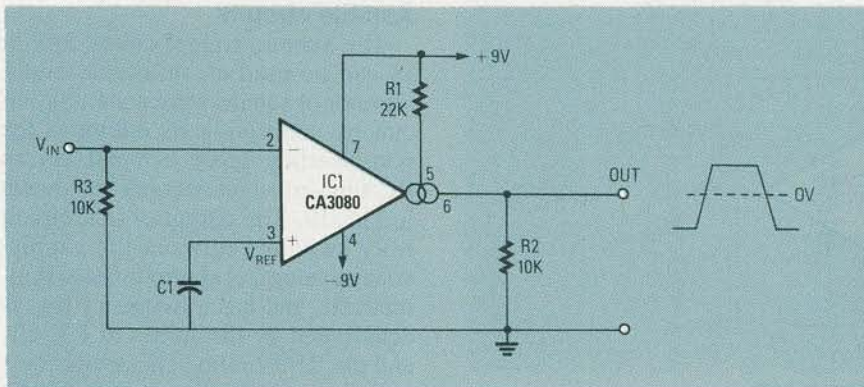

FIG. 15—A FAST INVERTING VOLTAGE comparator has a high output when its input falls below V_{REF} .

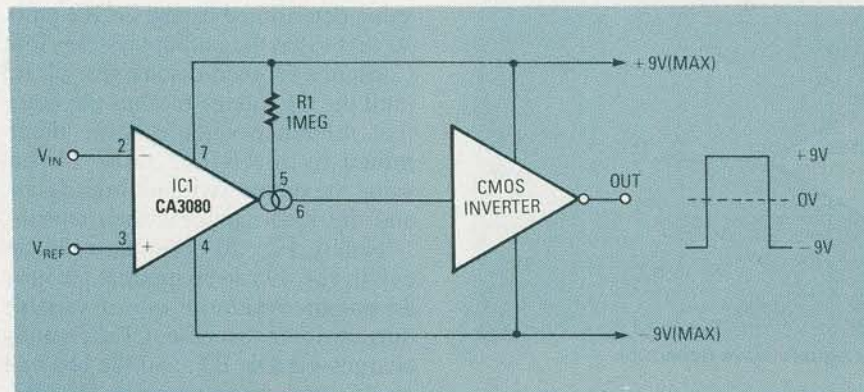

FIG. 16—A NON-INVERTING micropower voltage comparator has inputs that are sensitive to small changes.

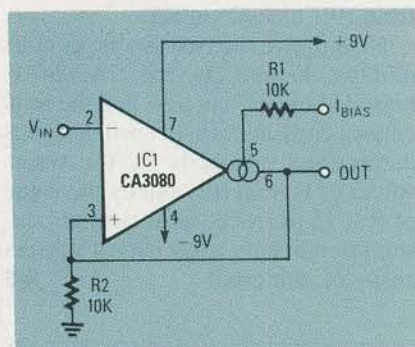

FIG. 17—THIS SCHMITT-TRIGGER circuit has programmable trigger-thresholds and peak-output.

$R3/R6$. The carrier signal is applied to the inverting pin of the CA3080 by the voltage divider R_x/R_1 . When R_x has a value of 33K as shown, and the modulation input terminal is tied to ground, the circuit basically has unity gain. The gain doubles when the modulation terminal is tied to +9 volts (+V), and when the modulation terminal is tied to -9 volts (-V) the circuit has roughly 80 dB of signal rejection.

The instantaneous polarity of the output signal of the circuit in Fig. 13 is determined entirely by the instantaneous polarity of the input sig-

nal. The amplitude of the output signal is determined by the product of the input and the gain-control values. That type of circuit is known as a 2-quadrant multiplier.

Figure 14 shows how the circuit in Fig. 13 can be modified so that it can be used as a ring-modulator or 4-quadrant multiplier, in which the output-signal polarity depends on the polarities of both the input signal and the modulation signal.

The circuits of Figs. 13 and 14 are identical, except that in Fig. 14, resistor-network R_y is connected between the input and output terminals. When the modulator input is tied to ground, the inverted signal flowing into R_5 from the OTA's output is balanced by the non-inverted signal flowing into R_5 from the input signal via R_y . Therefore, zero volts is generated across R_5 . If the modulation input goes to +V, the output of the OTA exceeds the current of the R_y network, and an inverted gain-controlled output is obtained. If the modulation input is -V, on the other hand, the output current of R_y exceeds that of the OTA, and a non-inverted gain-controlled output is obtained. So, both the phase and the amplitude of

the output signal of the 4-quadrant multiplier circuit are controlled by the modulation signal. The circuit can be used as a ring modulator by feeding independent AC signals to the two inputs, or as a frequency doubler by feeding identical sine-wave signals to the two inputs.

Note that with the R_x and R_y values shown in Fig. 14, the circuit has a voltage gain of 0.5 when the modulation terminal is tied to +V or -V. The gain doubles if the values of R_x and R_y are halved. Also note that the Fig. 13 and Fig. 14 circuits each have a high output impedance, and that in practice an output buffer must be added between the output terminal and the outside world.

Comparator circuits

The CA3080 can easily be used as a programmable or micropower voltage comparator. Figure 15 shows the basic circuit of a fast, programmable, inverting comparator, in which a reference voltage (V_{REF}) is applied to the non-inverting terminal and the test input is applied to the inverting terminal. The circuit's operation is such that the output is driven high when the test input is below V_{REF} and is driven low when the test input is above V_{REF} . The circuit can be used as a non-inverting comparator by reversing the input connections of the IC.

With the component values shown in Fig. 15, the I_{BIAS} current is several hundred μA , so the device has a slew rate of about 20V/ μs , and operates as a fast comparator. When the test voltage and V_{REF} are almost identical, the IC operates as a linear amplifier with a voltage gain of $gm \times R_2$ or about 200. When the two input voltages are significantly different, the output voltage is limited to values determined by the values of I_{BIAS} and R_2 . In Fig. 15, the output is limited to about 7 volts when R_2 has a value of 10K, or about 700 mV when R_2 has a value of 1K.

The circuit in Fig. 15 can be modified so that it is an ultra-sensitive micropower comparator, as shown in Fig. 16. That circuit typically consumes only 50 μA but has an output that fully swings between the +V supply and the -V supply, and can provide drive currents of several mA. In Fig. 16 the CA3080 is biased at about 18 μA via R_1 but has its output fed to the near-infinite input impedance of a CMOS inverter. That

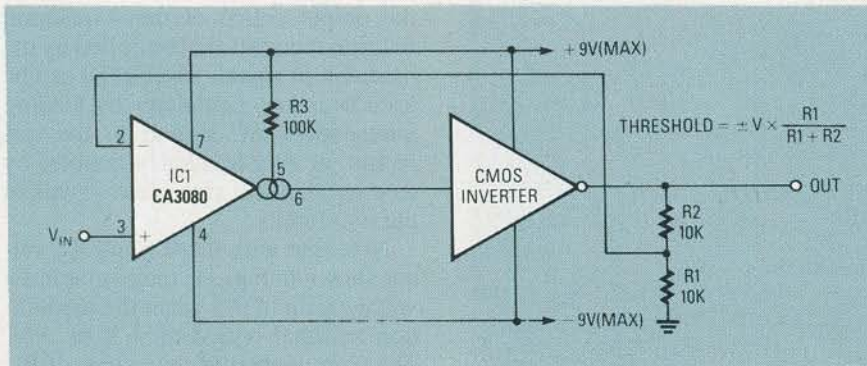

FIG. 18—A MICRO-POWER Schmitt trigger is shown here.

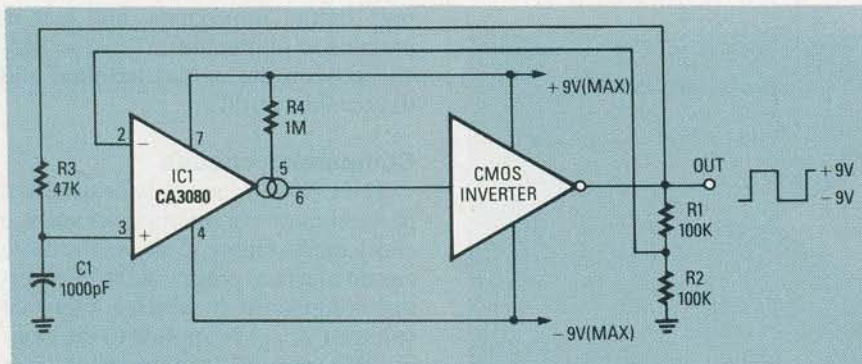

FIG. 19—A LOW-POWER astable multivibrator or square-wave generator.

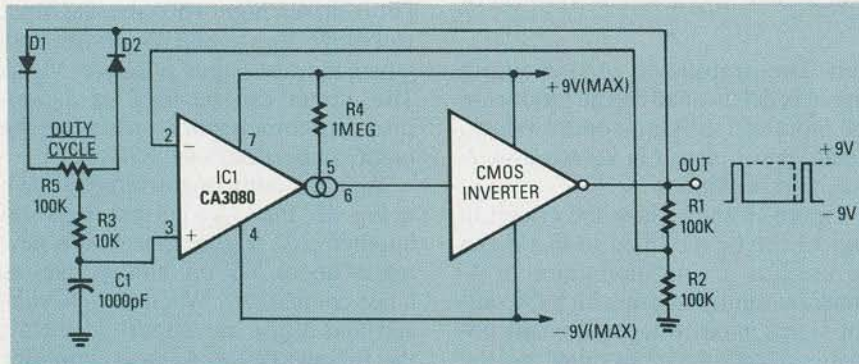

FIG. 20—THIS VARIABLE DUTY-CYCLE oscillator has an output that can be varied from 10:1 to 1:10. D

combination gives the circuit an overall voltage gain of about 130 dB, so that input-voltage changes of only a few μV are enough to switch the output from one supply level to the other.

Schmitt-trigger circuits

The voltage comparator circuit of Fig. 15 can be used as a programmable Schmitt trigger by connecting the non-inverting reference terminal directly to the output of the CA3080, as shown in Fig. 17. In that case, when the output is high, a positive reference value of $I_{\text{BIAS}} \times R2$ is generated. When V_{IN} exceeds that value, the output regeneratively switches low and generates a negative reference voltage

of $I_{\text{BIAS}} \times R2$, and when V_{IN} falls below that value, the output is regeneratively switched high and once more generates a positive reference voltage of $I_{\text{BIAS}} \times R2$. Therefore, the trigger thresholds, and also the peak output voltages of the Schmitt circuit, can be precisely controlled or programmed by changing the value of either I_{BIAS} or $R2$.

Figure 18 shows an another type of Schmitt trigger, in which the output fully switches between the supply-voltage values. The switching-threshold values are determined by the $R1/R2$ ratio and the supply-voltage values, and is equal to $+V \times R1/(R1 + R2)$.

Astable circuits

The Schmitt-trigger circuit in Fig. 18 can be used as an astable multivibrator or square-wave generator circuit by connecting its output to the non-inverting input terminal via an RC time-constant network, as shown in Fig. 19. The output of that circuit fully switches between the supply-voltage values, is approximately symmetrical, and has a frequency that is determined by the values of $R3$, $C1$, and the $R1/R2$ ratio. The operation is such that, when the output is high, $C1$ charges via $R3$ until the $C1$ voltage reaches the positive reference-voltage value determined by the $R1/R2$ ratio. At that value the output switches low. Capacitor $C1$ then discharges via $R3$ until the $C1$ voltage reaches the negative reference-voltage value determined by the $R1/R2$ ratio. At that value the output switches high again, and the whole process then repeats.

Finally, Fig. 20 shows how the circuit in Fig. 19 can be modified to have an output waveform with a variable duty cycle. In that case, $C1$ alternately charges via $D1$, $R3$, and the left half of $R5$, and discharges via $D2$, $R3$, and the right half of $R5$, to provide a duty-cycle ratio that is fully variable from 10:1 to 1:10 via $R5$.

Note that in the two astable circuits of Figs. 19 and 20, the CA3080 is biased at only a few μA , and the total current consumption of each design is determined primarily by the series values of $R1$ and $R2$, and by the value of $R3$. In practice, total current consumption of only a few tens of μA can easily be achieved. R-E

