

# BUILD A 200 WATT DIGITAL POWER AMPLIFIER FOR YOUR CAR

By: ALAN BAYKO



Here is a project that will add zip to your driving experience--a low-cost, high-end amplifier that's equally at home in your car, boat, or home!

Most audio power amplifiers currently available on the market are some kind of analog design. That seems perfectly reasonable since sound is an analog signal.

Unfortunately, high-powered amplifiers tend to be somewhat wasteful in power consumption, making them very hot when operating and fairly bulky due to their large heat sinks.

In the same way that switching-type power supplies are used in computer equipment for their compact size and efficiency, digital amplifiers have become a practical alternative to analog amplifiers. The 200-watt digital power amplifier presented here is designed to take advantage of that type of circuitry especially in the areas of size, power usage, and heat dissipation.

The 200-watt digital power amplifier presented here is a class-D, single-channel, audio power amplifier that can output 200 watts RMS into a 4-ohm load, or 100 watts RMS into an 8-ohm load. For stereo applications, two amps will be required. The amplifier will deliver that output power at a 96% efficiency with a distortion value under 1% at 1 kHz, all in a package that measures 7 x 4 x 2 inches. The supply voltage can be between 10 and 18 volts, making it an ideal car stereo amplifier.

**How It Works.** In analog amplifiers, the output transistors are biased to operate somewhere in the transistor's linear-operating range. That means that some current is always flowing through the transistor, as the transistor is rarely either fully on or fully off. Current flowing through a transistor when there is a sizable voltage difference between the collector and emitter terminals causes the transistor to

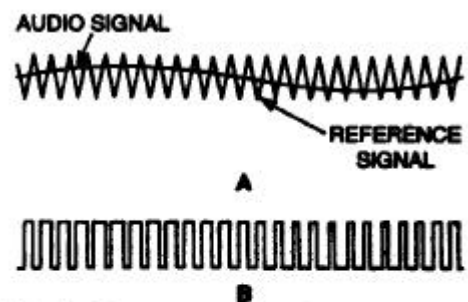

*Fig. 1. Comparing an audio signal to a high-frequency, triangle-wave, reference signal (A) results in a series of high-frequency pulses whose widths track the original (B). That is how a class-D amplifier works.*

dissipate heat. Class D amplifiers, on the other hand, pulse-width-modulate the input signal. The analog input signal is converted to an on-off pulse of a single, steady frequency. The width of the pulses depends on the voltage of the input signal. For example, one cycle of a simple sine wave will generate a train of pulses that start with a 50% duty cycle (the ratio of on to off in a pulse train). As the sine wave rises, the duty cycle will increase as the pulses get wider, then decrease as the sine wave returns to zero volts.

When the sine wave dips below zero volts, the process is reversed, with the pulses getting narrower then returning to a 50% duty cycle.

The conversion process will be easier to understand with the help of Fig. 1. A high-frequency triangle wave is used as a reference signal, and is compared digitally to the audio signal to be converted (Fig. 1A). If the voltage level of the audio signal is higher than the triangle-wave reference signal, the output is switched on. Naturally, when the audio signal is lower in voltage than the reference signal, the output turns off. That results in a pulse train similar to the one shown in Fig. 1B.

Pulses are easily amplified by a switching circuit. Switching circuits do not dissipate as much heat as their analog counterparts because there will be little or no voltage across the transistors when they are switched on, and no current flow when they are switched off. In either state, no power is consumed, so there will be little or no heat given off.

The major cause for loss of power in switching circuits is the dumping of the stored charge in the circuit while the circuit changes state. While the transistors are switching, they are passing through their linear operating region, which is where most (if not all) of the heat generated by the amplifier comes from.

Switching circuits, therefore, are very similar to CMOS logic circuits.

After the signal has been amplified, it is changed back to an analog signal by a low-pass filter. That removes the high-frequency signals introduced by pulse-width modulating the original signal. The result is an amplified version of the original input signal. If only inductive/capacitive filters are

used for the output filter, losses will be very low

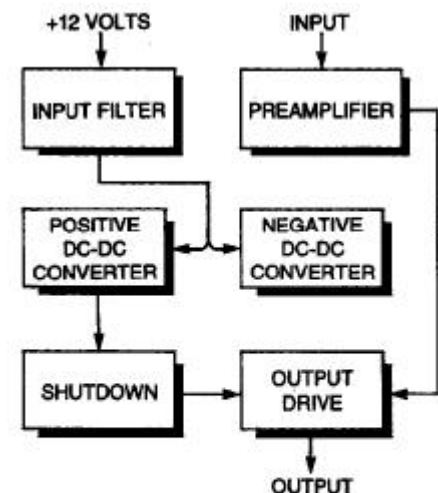

Fig. 2. The design of the 200-watt Digital Amplifier is quite straightforward. Most of the circuitry involved is connected with supply-voltage generation and fault detection.

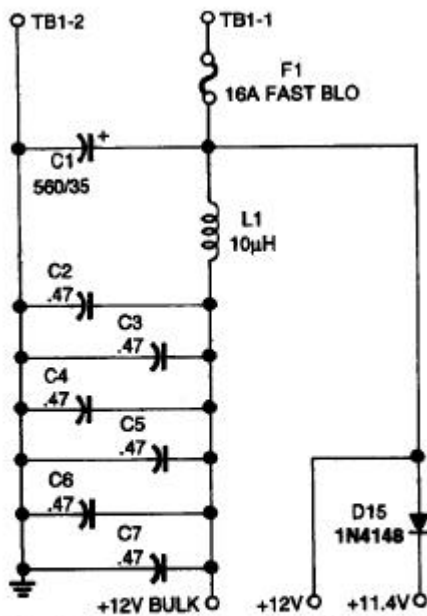

Fig. 3. The input filter for the 200-watt Digital Amplifier smooths out any supply voltage spikes—either from the power supply or from the amplifier.

Supply voltages for the 200-Watt Digital Amplifier are generated by a pair of DC-DC converters. Those converters are set up as current-mode controllers. In a current-mode controller, the amount of current flowing through a switching transistor is monitored. Knowing how much current is flowing allows the converter to control how much energy is being converted by turning the transistor off at the right time. By increasing the current allowed through the transistor, the total energy converted by the circuit can be controlled. The current shut-off point is controlled by an error amplifier that monitors the output voltage. If the output voltage drops, the current through the transistor is increased until the voltage returns to the control-circuit reference.

The power amplifier circuit can be divided into the following sections: input filters, positive and negative DC-DC converters, unbalanced-load shutdown circuit, pre-amplifier, ramp generator, output drive, and output filter. Those sections and their interconnections are shown in Fig. 2. Each section will be described in order.

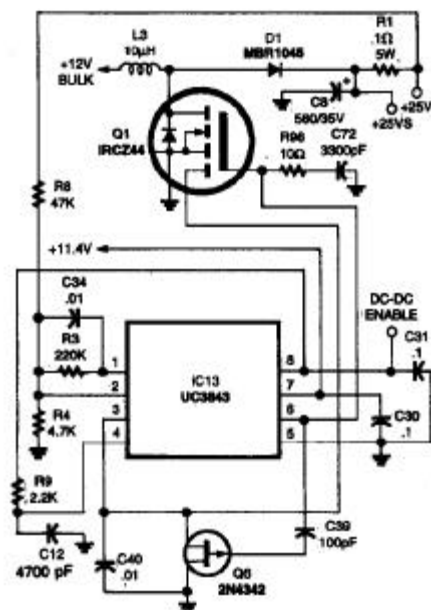

Fig. 4. The positive DC-DC converter creates a 25-volt power source from the 12-volt supply. An enable signal tells the rest of the circuit to shut down if the converter is having a problem.

### Input Filters And Converters.

The input filter (Fig. 3) smooths out any ripples that might appear in the supply voltage. The positive and negative DC-DC converters (Figs. 4 and 5) are both current-mode controllers. In both DC-DC converter circuits, the current is monitored using the voltage drop across the drain-source resistance of Q1 and Q14.

When Q1 is on, 12 volts is applied across L3, which causes current flow to build up through L3. The longer Q1 is on, the more current flows. When the error-amplifier portion of IC13 reaches the proper cutoff point, Q1 is turned off. The current in L3 continues to flow and is forced through D1 to the higher potential of the 25-volt supply. The current through L3 will decay because of the reverse potential across L3. After a preset time, Q1 is again turned on and the current through L3 will increase again. The current through L3 does not need to drop to zero before Q1

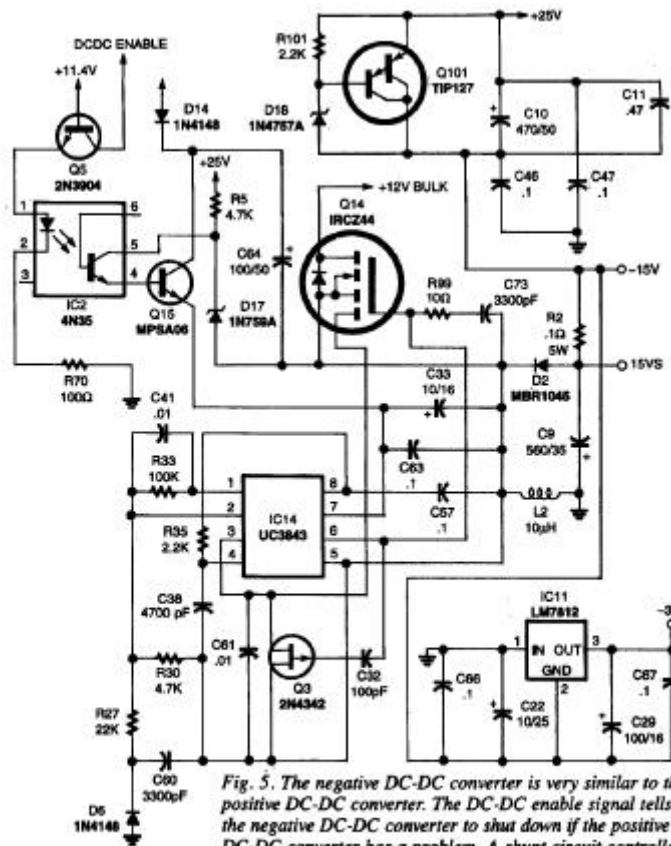

Fig. 5. The negative DC-DC converter is very similar to the positive DC-DC converter. The DC-DC enable signal tells the negative DC-DC converter to shut down if the positive DC-DC converter has a problem. A shunt circuit controlled by Q101 protects the amplifier from very inductive loads at low frequencies and high volume settings.

is turned on.

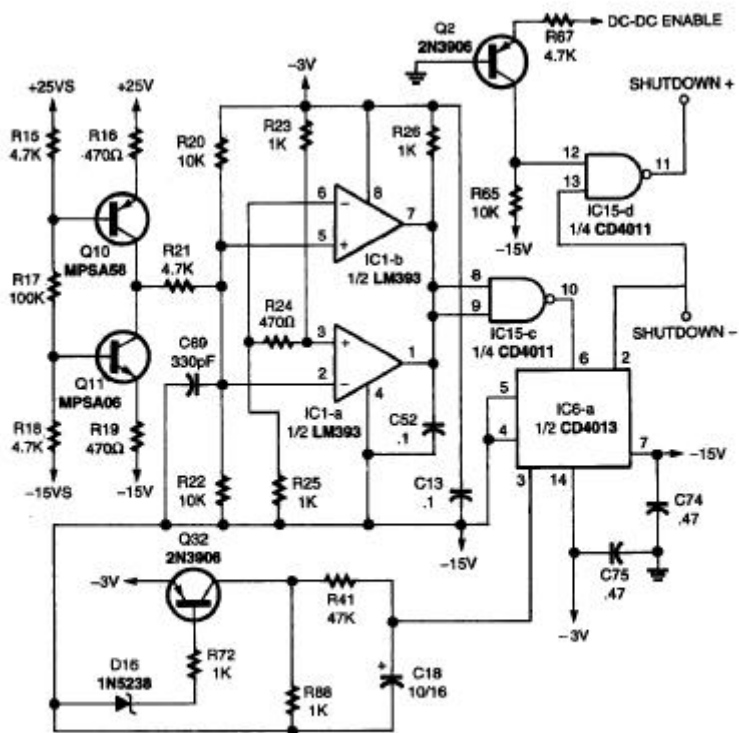

Fig. 6. The unbalanced-load shutdown circuit detects fluctuations in the supply voltages which would indicate a failure in one of the output transistors.

the amplifier output is shorted.

The negative DC-DC converter is very similar. The only difference is that Q14 and L2 are exchanged, and the polarity of D2 is reversed.

The positive DC-DC converter also generates an enable signal. In the event of a low-voltage condition, the positive DC-DC converter shuts down first. The positive DC-DC converter sends a signal to the negative DC-DC converter telling it to shut down, too.

**Shutdown Control.** The shutdown circuit of Fig. 6 is used to control whether the output transistors are active or shutdown. Three conditions under which the output transistors should be shut down are when the power supply is starting up and the voltages are not stable, the input voltage is dropping and the power supply is shutting down, and when

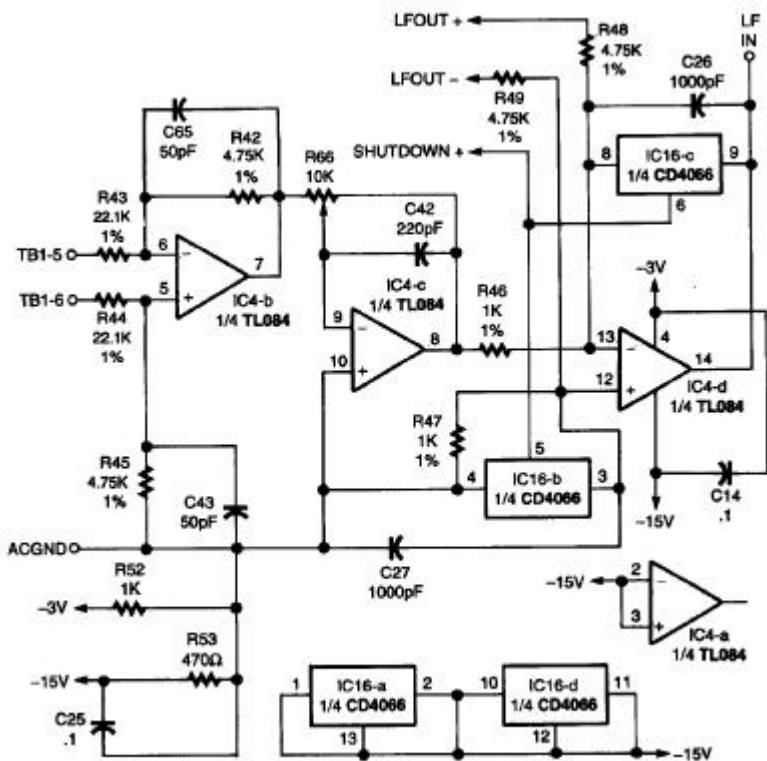

Fig. 7. The preamplifier conditions the input signal for pulse-width modulation.

To allow the power supply to stabilize on startup, the output transistors are not enabled for 1/2-second after the difference between the -- 3-volt and -- 15-volt supplies reaches 12 volts. By tying C52 to the -- 15-volt supply, IC6-a starts up in the shut-down state. That prevents a startup pop in the speaker.

The enable signal from the DC-DC converters overrides the output of IC6-a by combining both signals

using IC15-d. The enable signal goes low when the power supply is shutting down. That will temporarily shut off the output transistors until power voltages return to normal. The shutdown is temporary because it is possible for a signal spike to cause the external supply voltage to drop below 8 volts for a very short amount of time. When the amplifier is being turned off, a

shutdown pop in the speaker is also prevented.

The final cause of shutdown is detected by monitoring the current in the positive and negative

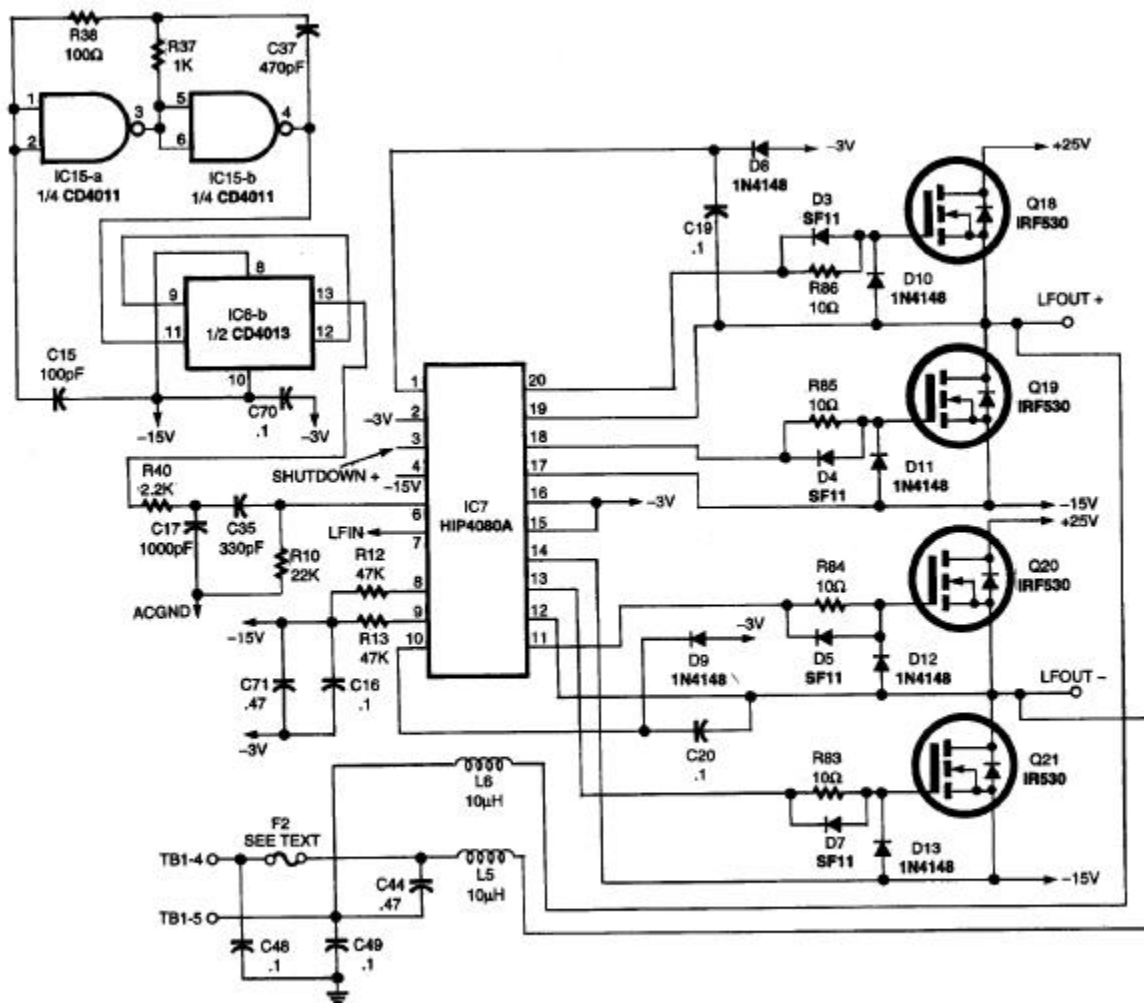

Fig. 8. The output drive circuit pulse-width-modulates and amplifies the signal. A pair of LC filters remove the high frequencies generated by pulse-width modulation.

supply lines with Q10, Q11, and C1. If the current in the negative supply is not the same as current in the positive supply, then there is a fault to ground. If that occurs, the output will be shutdown and not restarted until power is removed and

restored. There can be up to a 1-amp difference in the monitored currents before the amplifier is shut down to make up for component tolerances. A ground-fault shutdown is latched because it only occurs when there is a fault of some type in the wiring. If the shutdown is not latched in that condition, the amplifier would eventually damage itself.

**Pre-amplifier.** The pre-amplifier, shown in Fig. 7, is used to remove noise and condition the input signal for the drive circuit. It is also a part of the control loop for the output-drive circuit, and will be discussed later in this article.

The input signal is applied to both inputs of IC4-b. That method, called differential-input amplification, lets IC4-b remove any common-mode noise between the local AC ground and the signal-source ground. An added advantage of using differential inputs is that the entire

amplifier can be powered from an AC-isolated source, therefore preventing interference with other electronic devices. The amplifier gain can be set to any level between 0.125 and 125, with a gain of about 1.25 when R66 is set to its midpoint.

**Output drive.** The actual amplification is done by the output drive and support circuitry in Fig. 8. The audio signal is pulse-width modulated and the resulting pulses amplified. The ramp generator

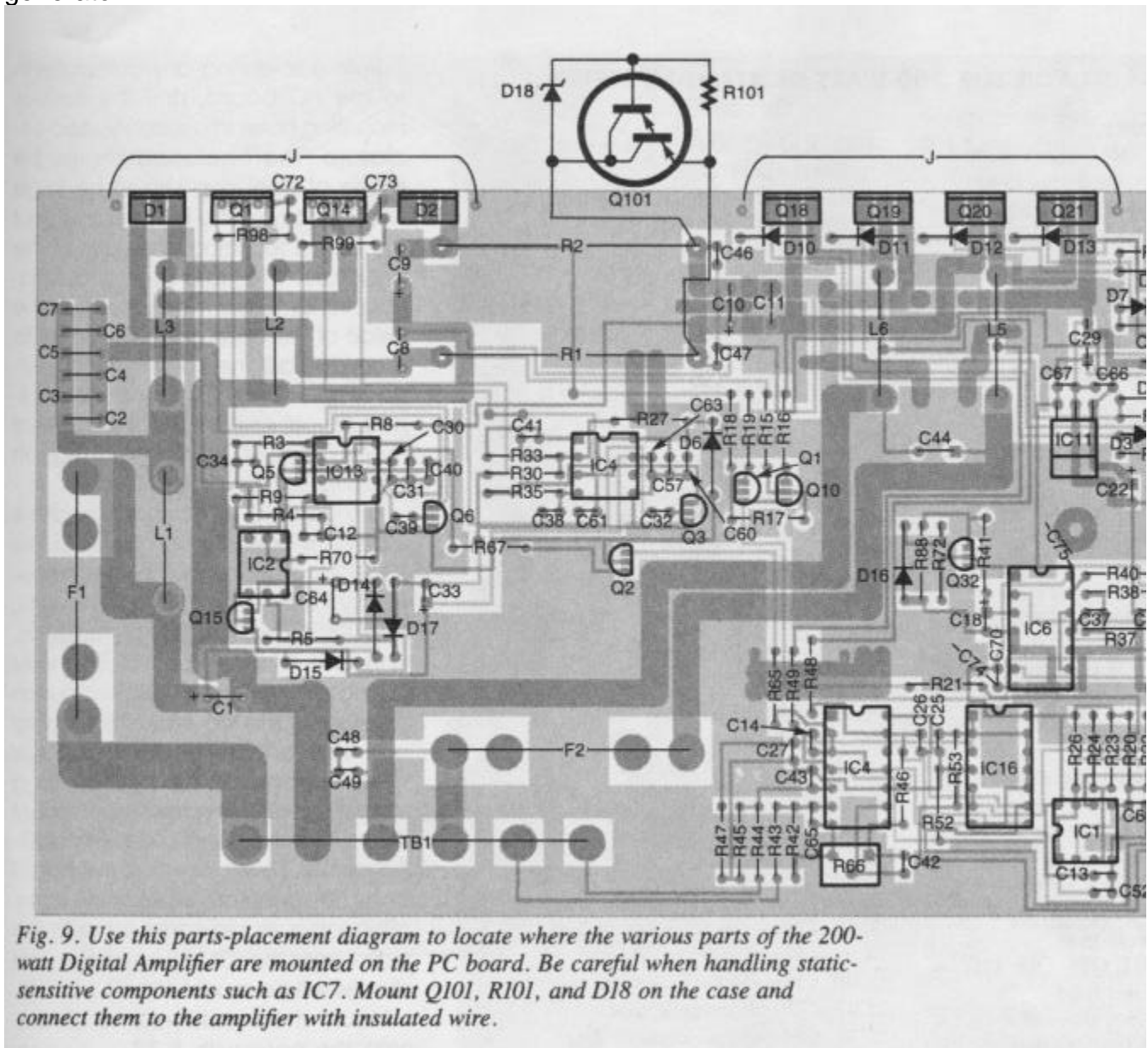

for the triangle-wave reference signal is a simple oscillator using two gates of IC15. That oscillator generates a fixed frequency of about 1 MHz. That frequency is divided in half by IC6, resulting in a perfect square wave. Resistor R40, along with C17 and C35, forms an integrator that changes the square-wave into a triangle wave.

The triangle wave is applied to IC7, where the actual pulse-width encoding is done. The encoder is placed in a control loop with the pre-amplifier. That reduces any distortion and noise. The distortion is caused by a less than perfect ramp and the bridge-drive dead time (when no output transistors are on). The control-loop error amplifier is IC4-d in the

pre-amplifier. It has a high-frequency roll off to keep the loop stable and make it immune to high-frequency switching noise.

The additional support circuitry in the output drive controls the turn-on speed of Q18--Q21 and prevents ringing. The turn-on speed of Q18--Q21 needs to be controlled in order to prevent current spikes. Those spikes originate from a freewheeling current (the speaker drive current) that turns on the body diodes of Q18-Q21. In order to prevent the stored charge in the diode from discharging too fast, the rise time of the gate voltage is limited. That discharge current is limited to about 30--50 amps.

If a short occurs across the outputs, then the fuse F2 should blow before any damage occurs. That fuse is also used to protect the speaker in the event of a transistor failure. Selecting the proper size is very important. In order to properly protect the speaker. The recommended maximum size for F2 is 16 amps.

**Construction. Important-** The high-frequency, high-current switching used in the 200-watt Digital Amplifier might cause interference in radio equipment. The layout of the printed-circuit board is designed to limit RF radiation and prevent destructive ringing in the circuit. Component placement is important, so *do not* attempt to build the amplifier on perfboard.

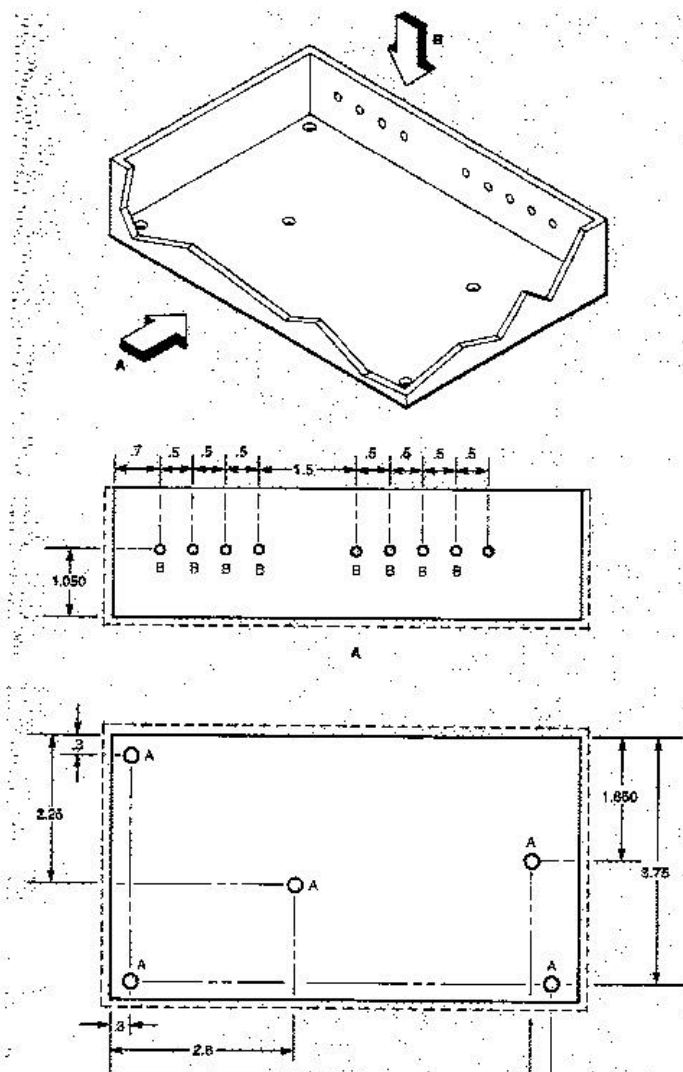

Building the 200-watt Digital Amplifier is quite straightforward. Simply install the components in the board and solder them in place, following the parts placement diagram in Fig. 9. However, installing certain components before others will make construction much easier.

Before soldering~ any components to the PC board, drill the various mounting holes in a suitably-sized enclosure. The enclosure should be made of steel and should be large enough to hold the PC board without the board touching any sides of the enclosure. The hole sizes and locations in Fig. 10 are measured from the inside of the case. Since it is easier to mark and drill the holes from the outside of the case, measure the Thickness of your cases walls and add that measurement to the information given in Fig. 10.

The case will also act as a heatsink for the transistors and diodes in the TO-220-style package. It is best to be-gin by installing DI, D2, Q1, Q14, Q19, and Q21. The remaining transistors, Q18 and Q20, will be installed later during testing. Put five 8-32 x -inch screws into the top side of the board and secure them in place with hex

nuts. Temporarily slip 1/4-inch long spacers over the screws and mount the PC board in the case with additional nuts. Make sure that the board does not touch any sides of the case, although it should come close to the side where the TO-220 transistors and

diodes will be mounted.

Mount the transistors and diodes onto the case with 8-32 x 1/4 inch screws and nuts. Solder each lead of the components to the top side of the board. Remove the PC board from the case, turn the board over, and solder each lead on the bottom side of the board. Do not solder two leads in a row on the same component-- skip from component to component. That will allow each solder joint to cool enough that it will not melt again, possibly allowing the component to shift position. If that happens-- the component will not line up properly with the mounting hole in the case when the board is reinstalled in the case. Due to the size of the components and PC board layout, C46 and C47 interfere with C10, and will be very difficult to place on the top side of the board. Those components should be mounted on the solder side of the board. Be sure to solder on both sides of the board for all components. If your board does not have plated-through holes. Circuit traces on both sides of the board must be connected together, including any unfilled holes.

You might want to install IC4 before R66, depending on the size of the trim pots case. If needed, you can mount R66 on top of IC4, standing R66 up off the board. Capacitors C74 and C75 should be installed after IC6 is installed. Tack solder one lead of C74 to pin 7 of IC6, and the other lead to the ground plane. Install C75 the same way to pin 14 of IC6.

When installing C11, be sure to use a mica insulator and insulated washer. The PC board's ground plane is used as a heatsink for C11. Any contact between C11's tab and the ground plane will short it.

There are 3 jumpers on the board that do not affect the circuit, but are required to reduce any radio-frequency interference (RFI) generated by the amplifier. They connect sections of the ground plane together. The jumper by R10 and C35 can be a scrap piece of resistor lead, but the two jumpers by the TO-220 transistors are much longer and should be insulated. Lengths of wire-wrap wire will do nicely. They should be dressed neatly along the edge of the board so they will not be pinched when the PC board is mounted in the case later. Transistor Q101 is mounted in the unused hole in the case next to Q18. Bend the leads of Q101 so that the length of the entire component is no more than 1 inch in length from the center of the mounting hole to the bend in the leads. That will ensure that Q101, R101, and D18 will fit in between Q18 and D2.

Cut two lengths of insulated wire. One wire will be about 1 inch long and the other will be about 2 inches long. Strip about 1/4-inch of insulation from each end. Trim one lead of R101 and solder that lead to the emitter lead of Q101. The same is done with the anode of D18, only solder D18 to the collector lead of Q101. Carefully bend the other lead of R101 so that it crosses the cathode lead of D18, and solder it to the base lead of Q101. Wrap the cathode lead of D18 around the lead of R101 that is connected to the base lead of Q101, and solder the two leads together.



Carefully tack-solder the longer insulated wire to the emitter of Q101 and the shorter wire to the collector of Q101. The shorter wire is wrapped around the right-hand lead of R2 and the longer wire around the right-hand lead of R1. Solder those two connections.

Since IC7 is *very* sensitive to static damage, it should be installed last. When installing IC7, make sure that you, your soldering-iron tip, and the circuit board are all properly grounded.

When all components except for Q18 and Q20 are installed, the amplifier is ready for testing. Be sure Q101 and its attached components are not touching any other components or the PC board.

**Testing.** Some of the voltages being measured during testing can only be measured when IC7 is disabled. Noise introduced into the circuit by measuring instruments can cause the circuit to malfunction. To measure the waveforms that do not have a return reference requires differential probes.

Connect the amplifier to a 12-volt power supply with a 4-amp capacity. If one is not available then use a supply with a 4700 uFd capacitor across its outputs. Place a jumper across R24 to induce a shutdown. Apply power to the amplifier. It should not use more than 1 amp of current with an input of 12 volts.

Using ground as a reference, you should measure between 25 and 38 volts at the cathode of D1, and --15 volts 20% at the anode of D2. The DC-DC enable signal (pin 8 of IC13) should measure somewhere between 4 and 6 volts.

Remove your voltmeters negative probe from ground and connect it to pin 2 of C11 (--15 volts) for the following measurements. Pin 3 of C11 should read 12 volts with a 10% tolerance. Pin 3 of IC6 and the shutdown signal at pin 11 of IC15 should both read between 8 and 12 volts. Pins 7,8, and 10 of IC4, along with pin 9 of IC16 should all read 4 volts 10%.

The triangle wave is best checked with an oscilloscope. Connect the oscilloscope probe to pin 6 of IC7, and

the ground to pin 2 of C11. The frequency of the triangle wave should be 1 MHz with a 40% tolerance and a 3-volt peak-to-peak level sitting 4 volts above the -- 15-volt reference.

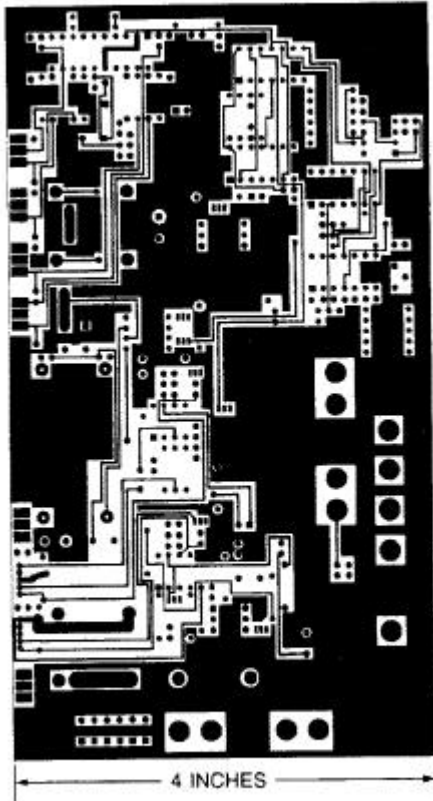

Here is the component side of the board. It is shown half size for space reasons.

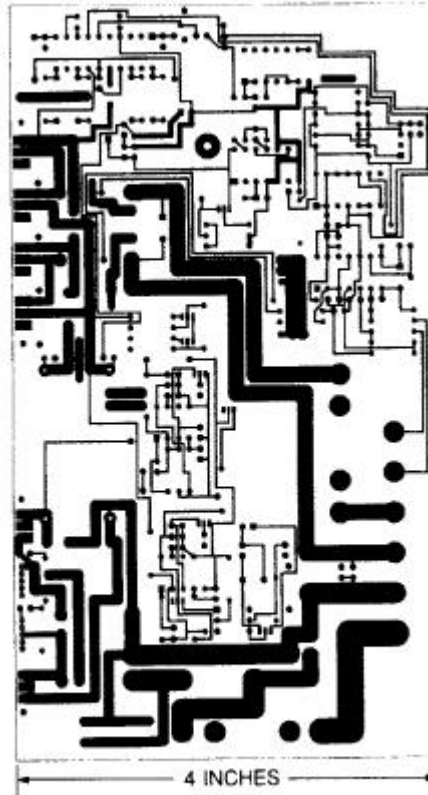

Here's the solder side of the board. It is shown half size for space reasons.

Now remove the jumper across

R24. Place a jumper across C26 and C27 to disable the pre-amplifier.

Again, using pin 2 of C11 as a reference, pin 3 of IC7 should be between 0 and 4 volts. On C1, pin 6 should read 4.8 volts, pin 3 should read 7.2 volts, and pin 5 should read 6 volts 10%. Replacing the voltmeter with an oscilloscope, a 12-volt square wave at 1 MHz should be present at pins 11, 13, 18, and 20 of IC7. Those measurements are referenced to pin 2 of C11.

Remove power from the amplifier and install Q18 and Q20. Use the holes in

the case to align the transistors in the same way as done for the other TO-220 components. Because of the other components on the board, you may use the holes from the outside of the case to align Q18 and Q20. Be sure to detach the case from the transistors before continuing the tests.

Re-apply power, and connect an oscilloscope's probe ground to TBI-2. A 1-MHZ square wave swinging between -15 and 25 volts should be present at pins 12 and 19 of IC7. The speaker outputs at TBI-4 and TBI-5 should both measure between 3 and 9 volts with a 3-volt ripple.

Now remove the jumpers across C26 and C27. With no input, the speaker outputs at TBI-4 and TBI-5 should both measure between 3 and 9 volts with a 3-volt ripple, referenced to pin 2 of C11. Connecting the oscilloscope probes between the speaker outputs should measure between -0.25 and 0.25 volts including ripple. If all the voltages are correct, then a signal source and speaker can be attached to test out the entire amplifier. Keep the audio test at a low volume until the board is permanently mounted in the case.

If everything checks out OK install the PC board permanently with the 1/4-inch spacers and nuts on the 8-32 screws mounted on the PC board. Use insulators, shoulder washers, and heatsink grease to attach the transistors to the case with appropriate screws and nuts.

If one of the FETs should burn out, it will usually destroy the other FET in that side of the bridge. It can also destroy IC7. Replace the FETs in pairs. When installing the new FETs, IC7 can be tested by placing a jumper across C26 and C27, installing the low-side drive FET, and

checking for the square wave gate drive from IC7. If the square wave is not present on both FETs, then IC7 should be replaced. Once both gate drives are working, the high-side drive FET can be installed and the jumpers removed.

**Using The Amplifier.** When installing the amplifier, make sure that the input impedance of the 12-volt supply is less than 1 ohm. If the amplifier is to be installed in a home setting, or other location in which power will be drawn from a 117-volt wall socket be sure that the 12-volt supply output has adequate isolation in order to avoid any shock hazard.

The differential inputs are very useful since the amplifier ground does not have to be at the same potential as the signal source ground. The negative input may be hooked to the source ground, using the positive input for the signal.

If you are driving the amplifier with an output that was meant to be connected directly to a speaker, you might need to add an 8-ohm resistor across the input terminals in order to reduce noise.

## **PARTS LIST FOR THE 200-WATT DIGITAL AMPLIFIER**

D1, D2--MBR1045 silicon diode

D3--05, D7,--SFI1 silicon diode

D6, D8--D15--1N4148 silicon diode

D16--1N5238 Zener diode

D17--1N759A Zener diode

D18--1N4757A Zener diode

IC1--LM393 dual comparator, integrated circuit

IC2--4N35 optoisolator. integrated circuit

IC3, IC5, IC8--IC10, IC12--not used

IC4--TL084 quad op-amp, integrated circuit

IC6--4013 dual D-type flip-flop, integrated circuit

IC7--HIP4080AIP full-bridge driver, integrated circuit

IC11--7812 12-volt regulator, integrated circuit

IC13, IC14--UC3843 current-mode controller, integrated circuit

IC15--4011 quad nand gate, integrated circuit

IC16--4066 quad bilateral switch, integrated circuit

Q1, Q14--IRCZ44 N-channel field-effect transistor

Q2, Q32--2N3906 PNP transistor Q3, Q6--2N4342/J175 P-channel field-effect transistor

Q4, Q7--Q9, Q12, Q13, Q16, Q17, Q22--Q100---not used

Q5--2N3904 NPN transistor

Q10--MPSA56 PNP transistor

Q11, Q15--MPSA06 NPN transistor

Q1&-Q21--1RF530 N-channel field-effect transistor

Q101--T1P127 PNP Darlington transistor

## **RESISTORS**

(All resistors are -watt, 5% units unless otherwise noted.)

R1, R2--0.1-ohm, 5-watt, 10%

R3--220,000-ohm

R4, R5, R8, R12, R13, R15, R18, R21, R30, R41, R67--4700-ohm

R6, R7, R11, R14, R28, R29, R31, R32, R34, R36, R39, R50, R51, R54--R64, R68, R69, R71, R73--R82, R87, R89-R97, R100-- not used

R9, R35, R40, R101--2200-ohm

R10, R27--22,000-ohm

R16, R19, R24, R53--470-ohm

R17, R33--100,000-ohm

R20, R22, R65--10,000-ohm

R23, R25, R26, R37, R52, R72, R88--1,000-ohm

R38, R70--100-ohm

R42, R45, R48, R49--47,500-ohm, 1/4-watt, 1%, metal-film

R43, R44--22,100-ohm, 1/4-watt, 1%, metal-film

R46, R47--1,000-ohm, 1/4-watt, 1%, metal-film

R66--10,000-ohm, variable (BOURNS 3386P-I-103 or similar)

R83--R86, R98, R99--10-ohm

#### CAPACITORS

Cl, C8, C9--560 uF, 35WVDC, electrolytic, low ESR-type

C2-C7, C11, C44, C71--0.47 uF, ceramic disc

C10--470 uF, 50WVDC, electrolytic, low ESR-type

C12, C38--4700 pF, ceramic disc

C13, C14, C16, C19, C20, C25, C30, C31, C46-C49, C52, C57, C63, C66, C67, C70--0.1 uF, ceramic disc

CiS, C32, C39--100 pF. ceramic disc

C17, C26, C27--1000 pF, ceramic disc

C18, C33--10 uF, 16WVDC, electrolytic

C21, C23, C24, C28, C36, C45, C50, C51, C53--C56, C58, C59, C62, C68--not used

C22--10 uF, 25WVDC, electrolytic

C29--100 uF, 16WVDC, electrolytic

C34, C41--0.01 uF ceramic disc

C35, C69--330 pF. ceramic disc

C37--470 pF ceramic disc

C40, C61--0.01 uF, ceramic disc

C42--220 pF, ceramic disc

C43, C65--50 pF. ceramic disc

C60, C72, C73--3300 pF. ceramic disc

C64--100 uF, 50WVDC, electrolytic

C74, C75--0.47 uF, ceramic disc

## **ADDITIONAL PARTS AND MATERIALS**

LI--L3, L5, L6--10-amp, 10 uH coil (Miller 5502 or similar)

L4- not used

FI--16-amp fast-blow fuse

F2--see text

TBI--Terminal strip, 6-terminal, PC-mount

Printed-circuit board, case, PC-mount fuse clips, 4-40 x 1/4-inch screws, 4-40 washers, 4-40 nuts, 8-32 X 1/2-inch screws, 8-32 x 3/4-inch screws, 8-32 nuts, TO-220 mica insulators, no. 8 x 1/4-inch spacers, etc.

Note: The following items are available from: Radical Electronics, Inc., 115 Hall Cr., Saskatoon, SK S7L 7G7, Canada, Tel/Fax: 306-384-8777: Kit of all parts less case, \$100. Circuit board only, \$23. IC7, \$12. Add \$4 for shipping charges. Prices for other parts are available on request. Prices listed are in US dollars.