

HARMAN INTERNATIONAL

RELIABILITY TEST PLAN

for

**AUTOMOTIVE AMPLIFIED
SUBWOOFER**

harman consumer group

Central Quality Group

Release Date: 12/1/00

Revision Level: B

Revision Level Date: 08/16/01

1.0 Purpose

The purpose of this test plan is to describe the environmental and functional performance requirements to which the Amplifier will undergo in order to be validated. The intent of the validation program is to expose the Amplifier to an accelerated aging process.

2.0 Test Plan

This document details the type of tests and the number of units required for each. The sample size outlined below can be used as a guideline and may change depending on the Reliability Target.

2.1 Full Qualification

The full qualification test program consists of the groups listed below. These groups are designed to be performed in parallel. This test plan must be done on at least one member of a “Product Family”. The most complex or highest power model should be chosen.

Group	QTY		Test Name	Spec. Sect. No.	Functional Test Requirements
	DV	PV			
A	2	6	Life Cycle	5.1.1	4.1 - 4.6
B	2	6	Power Test	5.5	4.1 - 4.6
			Thermal Shock	5.2	4.1 - 4.6
			Temperature Storage	5.7	4.1 - 4.6
C	2*	6	Package Test (ASTM)	5.9	4.1 - 4.6
			Operating Humidity	5.6	4.1 - 4.6
			Operating Vibration	5.3	4.1 - 4.6
			Limitation Drop**	5.8.1	for information only
D	2	6	Operating Voltage Range	5.10	4.1 - 4.6
			Voltage Supply Extremes	5.11	4.1 - 4.6
			Shorted Output	5.12	4.1 - 4.6
			Load Dump	5.13	4.1 - 4.6
			ESD	5.14	4.1 - 4.6

* If packaging is available test 2 units

** Specified by Product Manager

2.2 Abbreviated Qualification

The abbreviated test program consists of a single group of units and is design to be done in series as listed below. This test plan must be done on all members of a “Product Family” not subjected to the full qualification outlined in section 2.1.

Group	QTY		Test Name	Spec. Sect. No.	Functional Test Requirements
	DV	PV			
A	6	6	Operating Humidity	5.6	4.1 - 4.5.2
			Power	5.5	4.1 - 4.5.2
			Vibration	5.3	4.1 - 4.5.2
			Life Cycle	5.1.1	4.1 - 4.5.2

3.0 Standard Test Conditions

3.1 Supply Voltage/Current

A supply voltage, as specified in the Product Specification as nominal value, shall be applied to the unit under test for all measurements unless otherwise specified. The voltage applied to the unit shall be regulated at the power connection on the amplifier. The power supply shall be capable of supplying at least +10% voltage and current above the maximum specified on the Product Specification to the amplifier (load) over a continuous voltage range specified in the Product Specification. Any incidental supply voltage ripple and or noise shall be less than -70dBV in magnitude.

3.1.1 Operating Voltage

The operating voltage is defined as the high and low voltage that the unit will operate within and not produce any noises such as: pops, ticks, whistles, etc. The two operating voltages are to be specified in the Product Specification.

3.2 Signal Source

Unless otherwise specified, all tests shall be conducted with the Audio Precision output configured to be unbalanced, less than or equal to 50-ohm source impedance, and floating. The signal source chassis GND shall be connected to the power supply GND.

3.2.1 Reference Frequency

The reference frequency is to be as specified in the Product Specification.

3.2.2 Music

Set the specified output level at the reference frequency using a CD with test tones. Then forward to track #17 “Crime Stories” and set the CD player to REPEAT.

3.2.3 Noise

The products are divided into three groups, full range (multi-element), mid-bass and subwoofer. The type of product shall be specified on the Product Specification.

Full Range will use IEC noise with a crest factor of 9dB. The RMS voltage shall be specified on the Product Specification.

Mid-bass will use a decade of pink noise, 50 to 500Hz (-3dB points), 12dB slopes, with a crest factor of 9dB. The RMS voltage shall be specified on the Product Specification.

Sub-woofer will use a decade of pink noise, 30 to 300Hz (-3dB points), 12dB slopes, with a crest factor of 9dB. The RMS voltage shall be specified on the Product Specification.

3.3 Measurement Bandwidth

Unless otherwise noted, all measurements are made through an Audio Precision using a high-pass and low-pass filter isolating the operating frequency bandwidth as specified in the product specification.

3.4 Standard Operating Condition

Unless otherwise specified, all tests shall be conducted in the default mode with all input channels driven in parallel and in phase, and all output channels simultaneously loaded. Use right front channel for setting the reference level. If unit has variable gain, set control so that at the specified reference frequency the output is at the maximum specified power. Any adjustable controls such as: EQ, limiter, crossovers, etc. should be defeated.

3.5 Amplifier Position

Unless otherwise specified, the amplifier shall meet all requirements in the “normal mounting position” with at least 1-inch of free air space on all free sides of the Heat Sink.

3.6 Room Temperature

Unless otherwise specified, all measurements shall be made at room temperature. Room temperature is specified as 25 °C +/- 3 °C.

3.7 Operating Temperature

Unless otherwise specified, all operating temperature measurements shall be made at both -30C +/-3 °C and +70 °C +/-3 °C with a soak time of 10 minutes. When taking measurements, some settling time may be needed and should not exceed one minute.

4.0 Functional Requirements

Functional requirements are to be tested in accordance with an HCG approved product engineering specification.

4.1 THD+N @ Rated Output Power

This test is used to demonstrate that the amplifier is capable of producing its rated power output. Total harmonic distortion plus noise (THD+N) is measured for each channel independently at that channel's rated output level. The input signal level shall be adjusted to obtain the specified output power for each channel in turn as it is measured. This test is to be done with the limiter circuit defeated.

	<u>TYP.</u>	<u>MAX.</u>	<u>UNITS</u>
Room Temperature	Refer to Product Specification		%
Operating Temp. (High & Low)		“	%
Operating Voltage (High & Low)		“	%

4.2 THD+N @ 1 Watt Output Power

THD+N is measured independently for each output channel at a power level of 1 Watt and at reference frequencies specified for each channel on the Product Specification. This test confirms the amplifier THD+N at a linear region below clipping.

	<u>TYP.</u>	<u>MAX.</u>	<u>UNITS</u>
Room Temperature	Refer to Product Specification		%
Operating Temp. (High & Low)		“	%
Operating Voltage (High & Low)		“	%

4.3 Gain

The amplifier gain from input to each output channel is measured at that channel's reference frequency as listed on the Product Specification. Input signal level for this measurement is also specified on the Product Specification. If the unit has a variable gain the minimum and maximum gain is to be checked. Refer to Section 3.5.

	<u>TYP.</u>	<u>MIN.</u>	<u>MAX.</u>	<u>UNITS</u>
Room Temperature	Refer to Product Specification			dBr
Operating Temperature	Refer to Product Specification			dBr

4.3.1 Frequency Response

The amplifier should be tested for frequency response at 1 Watt with reference to the reference frequency specified in the Product Specification. Any filter required for testing should be specified in the Product Specification.

	<u>TYP.</u>	<u>MIN.</u>	<u>MAX.</u>	<u>UNITS</u>
Room Temperature	Refer to Product Specification			dBr
Operating Temperature	Refer to Product Specification			dBr

4.4 Equalization and Filters

Amplifier equalization or filters are measured as frequency relative to a reference gain at the test frequency specified for each output channel on Product Specification. The

measurements are made with a fixed, specified input signal amplitude and with the amplifier operating into the specified loads.

For each output channel, measure the amplitude of the output voltage at the channel's reference frequency with controls set to flat if applicable. Using this voltage as a 0 dB reference, measure and record the relative output for each control and each channel for the (up to) five test frequencies as specified in the Product Specification for each channel. The result is the deviation of the (up to) five response measurements from the nominal values listed on the Product Specification.

	<u>TYP.</u>	<u>MIN.</u>	<u>MAX.</u>	<u>UNITS</u>
Room Temperature	Refer to Product Specification			dBr
Operating Temperature	Refer to Product Specification			dBr

4.5 Noise Levels

All noise level measurements are A-weighted unless otherwise specified. This assures that the measured noise voltage closely corresponds to the audibility of that noise.

4.5.1 Signal to Noise

4.5.1.1 Signal to Noise at Full Power

This test is used to verify published spec. as specified in product's literature. Using the reference frequency adjust the input signal until the output is equal to the maximum specified power (see Product Specification). The output voltage obtained is now to be used as the reference. Terminate the inputs with a 50-ohm source impedance.

	<u>TYP.</u>	<u>MAX.</u>	<u>UNITS</u>
Room Temperature	Refer to Product Specification		dBr
Operating Temperature	Refer to Product Specification		dBr

4.5.1.2 Signal to Noise at 1 Watt

This test measures the actual audible noise at a 1Watt reference for all amplifiers. Using the reference frequency, adjust the input signal until the output is equal to the maximum specified power (see Product Specification). The output voltage obtained is now to be used as the reference. Terminate the inputs with a 50-ohm load.

	<u>TYP.</u>	<u>MAX.</u>	<u>UNITS</u>
Room Temperature	Refer to Product Specification		dBr
Operating Temperature	Refer to Product Specification		dBr

4.5.1.3 A+ Induced Noise

All amplifier units should be subjected to the induced noise test. The inputs are terminated with 50-ohm source impedance and the background noise level is measured for each output channel. Set-up test as shown in Fig. 1.

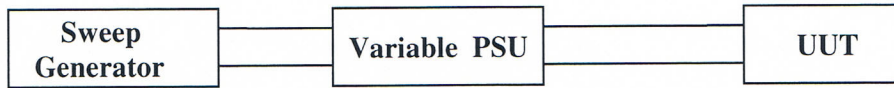

Fig. 1 Test setup: Supply Voltage Ripple

DC supply voltage “A⁺” of the test unit is superimposed with a sinusoidal AC voltage A (Fig. 2) having the following parameters.

Amplitude	A= +/- 2V
Frequency Range	50 Hz to 20Khz, swept
Sweep Frequency	5 mHz to 1 Hz
Test Period	5 minutes

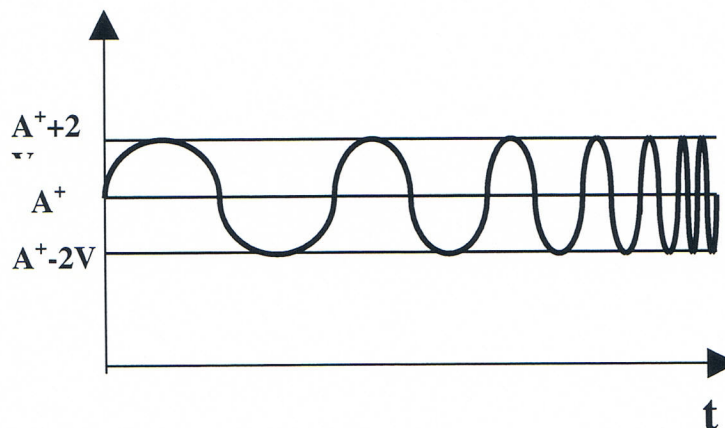

Fig. 2 A⁺ Superimposed Sinusoidal AC Voltage

	<u>TYP.</u>	<u>MAX.</u>	<u>UNITS</u>
Room Temperature	Refer to Product Specification		mVrms
Operating Temperature	Refer to Product Specification		mVrms

4.5.2 Input Common Mode Rejection (For use on differential inputs only)

The input signal source is configured to apply a sine wave with amplitude and frequency equal to input sensitivity and reference frequency specified in the Product Specification. With both input-signal-high and signal ground connected together and to the generator measure the different output levels.

	<u>TYP.</u>	<u>MAX.</u>	<u>UNITS</u>
Room Temperature	Refer to Product Specification		dBr
Operating Temperature	Refer to Product Specification		dBr

4.6 Extraneous Noise

The speaker assembly shall not produce extraneous noise when a dynamic test is performed. The following types of deficiencies are some typical causes of extraneous noise:

1. **Buzz:** Any noise produced by a looseness of components vibrating against other components.
2. **Rub:** Any noise produced by the voice coil sliding or rubbing against other components.
3. **Bottoming:** The noise produced by the contact of the moving system with the speaker structure.
4. **Rattle:** The random noise produced by an object trapped within the speaker allowed to strike moving components, or any intermittent noise caused by loose electrical connections or controls.
5. **Frozen Coil:** Absence of free excursion caused by adhesive in the magnetic gap or an offset (loose) component of magnetic circuit.
6. **Air Noise:** The noise produced by high velocity airflow through a small leak.

4.7 Crosstalk

This test is conceived to provide a crosstalk measurement that reflects the actual use of the product. All of the amplifier channels are driven to 1 Watt into rated load except test channel. The undriven input is terminated with 50-ohm source impedance. The output voltage of the channel(s) corresponding to the undriven input is measured in series. Each of the input channels is undriven in turn. The test result is expressed in dBr with respect to a reference channel.

	<u>TYP.</u>	<u>MAX.</u>	<u>UNITS</u>
Room Temperature	Refer to Product Specification		dBr
Operating Temperature	Refer to Product Specification		dBr

4.8 Minimum and Maximum Current Draw

The minimum current shall be measured with the unit ON and inputs terminated with a 50-ohm source impedance. The maximum current shall be measured with all channels driven with the reference frequency to the main specified power.

	<u>MIN.</u>	<u>MAX.</u>	<u>UNITS</u>
Room Temperature	Refer to Product Specification		Amp
Operating Temperature	Refer to Product Specification		Amp

4.9 On/Off Transients - Remote/Main

With all inputs terminated with 50 ohm source impedance, each channel is observed with a peak hold voltmeter as the amplifier is turned ON and OFF. A bandpass filter with 100 Hz - 22 kHz 18 dB/octave is used between the amplifier and the voltmeter. Turn-on transients should be measured after the amplifier has been OFF for at least 20 seconds and, conversely, turn-off transients are measured after the amplifier has been ON for at least 20 seconds. The remote test is to be conducted by removing the remote voltage from the unit. Average of 5 consecutive measurement should be recorded for each test.

	<u>TYP.</u>	<u>MIN.</u>	<u>MAX.</u>	<u>UNITS</u>
Room Temperature	Refer to Product Specification			Vrms
Operating Temperature	Refer to Product Specification			Vrms

The Main test is to be conducted by removing both Remote and Main voltage simultaneously from the unit.

	<u>TYP.</u>	<u>MIN.</u>	<u>MAX.</u>	<u>UNITS</u>
Room Temperature	Refer to Product Specification			Vrms
Operating Temperature	Refer to Product Specification			Vrms

4.10 Temperature Characteristics

4.10.1 Temperature Profile Test

Each amplifier is to be tested in a controlled volume of air in which the amplifier unit does not experience any laminar or turbulent airflow on its heat sink. The amplifier is to be exposed to 1/8 of its rated power with a signal input of 9dB crest factor IEC Pink Noise with the resistive load specified in the Product Specification. During the 90-minute test, temperatures should be measured at the following locations: Output transistors (collector temperature), heat sink (external close to output transistors mounting area) and ambient temperature at a location of a minimum of 8 inches from any surface of the amplifier.

During test period, thermal measurement and a single channel output shall be monitored every 2 minutes.

	<u>MAX.</u>	<u>UNITS</u>
Operating Temperature (3 Loc.)		°C

4.10.2 Rock Test / Ambient Temperature Test

Each amplifier is to be tested in a controlled volume of air in which the amplifier unit does not experience any laminar or turbulent airflow on its heat sink. The amplifier is to be exposed to music (as referenced in 3.2.2 Music) at full rated output. The gain should be set with a CD that contains a signal with 0dBu at the reference frequency. The level should then be adjusted for the maximum rated output power with the minimum rated load. During 120-minute test, temperatures should be measured at the following locations: Output transistors (collector temperature), heat sink (external close to output transistors mounting area) and ambient temperature at a location of a minimum of 8 inches from any surface of the amplifier.

During test period, thermal measurement and a single channel output shall be monitored every 2 minutes.

	<u>MAX.</u>	<u>UNITS</u>
Operating Temperature (3 Loc.)		°C

4.10.3 Rock Test / Ambient Temperature Test

Repeat above test in a controlled volume of air at temperature set to 70 °C for 2 hours. Monitor thermal activities at the same location.

	<u>MAX.</u>	<u>UNITS</u>
Operating Temperature (3 Loc.)		°C

4.10.4 Temperature Drift Test / Tone Burst

Each amplifier is to be tested in a controlled volume of air at ambient temperature of 70 °C. Signal input to the test units is a Burst signal (Interval = 20, Burst ON = 3, Low level = -10 dB) which drives output at 4% THD. During the 60-minute test, temperatures should be measured at the following locations: Output transistors (collector temperature), heat sink at highest human contact point and ambient temperature at a location of a minimum of 8 inches from any surface of the amplifier. During test period, thermal measurement and a single channel output shall be monitor every 2 minutes.

	<u>MAX.</u>	<u>UNITS</u>
Operating Temperature (3 Loc.)		°C

5.0 Qualification Testing

The reliability target for all car amplifier products are zero defects at 3 years operation. Successful completion of the test is intended to demonstrate 90% reliability with 90% confidence.

5.1 Life Cycle Test

Each amplifier shall withstand 5 cycles (totaling 215 hours) of the environmental conditions outlined below. The amplifiers output should be checked once a day on a regulars basis. A full functional test should be performed on all units at the end of second and fifth cycle.

- A. Over a 30-minute period, raise the temperature to 40°C with a relative humidity of 95%.
- B. Stabilize the temperature at 40°C with a relative humidity of 95% for 16 hours. After 6 ½ hours, apply the designated noise (3.2.3 Noise) at 1/8th of the rated power. At the end of the 16-hour period, remove the signal.
- C. Over a 30-minute period, raise the temperature to 90°C with a relative humidity of <20%.
- D. Stabilize the temperature at 90°C with a relative humidity of 20% for 8 hours. After 3 hours, apply the designated noise at 1/8th of the rated power. At the end of the 8-hour period, remove the signal.
- E. Over a 30-minute period, lower the temperature to 25°C.
- F. Stabilize the temperature at 25°C for 2 hours.
- G. Over a 30-minute period, lower the temperature to -35°C.
- H. Stabilize the temperature at -35°C for 5 hours. After 2 hours, apply the designated noise at 1/8th of the rated power. At the end of the 5-hour period, remove the signal.
- I. Over a 1-hour period, raise the temperature to 90°C.
- J. Stabilize the temperature at 90°C for 5 hours. After 2 hours, apply the designated noise at 1/8th of the rated power. At the end of the 5-hour period, remove the signal.
- K. Over a 30-minute period, lower the temperature to 25°C.
- L. Stabilize the temperature at 25°C for 3.5 hours.

M. This is the end of one cycle.

Ref. Chrysler PF 9506

2.2.2.1 Damp/Dry Cycling & 2.2.2.5 Temperature Test

95% rh

Car Product Life Cycle

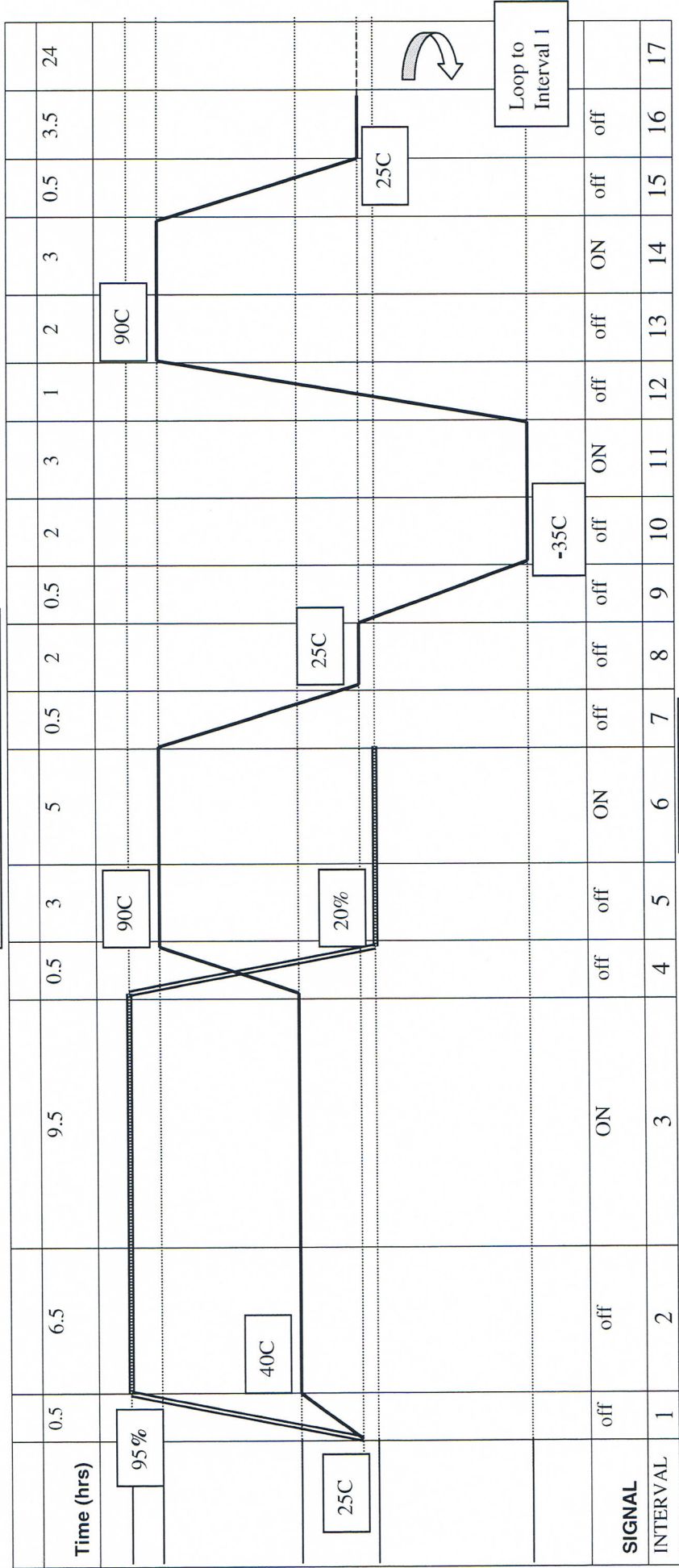

ONE CYCLE
(43 hours)

Car Life Cycle Functional Intervals

3.60 days for 50% functional (2 cycles)
5.38 days for 100% functional (3 cycles)

Temperature (°C)
Humidity (%RH)

Loop to Interval 1



5.2 Thermal Shock (Non-operating)

Each amplifier shall withstand 50 cycles of thermal shock from -40°C to +85°C with a minimum of 1-hour soak at each temperature extreme. The amplifier shall be transferred from one temperature extreme to the next within 12 seconds in order to induce thermal shock. Leave the unit for a minimum of 2 hours at room temperature before any post test evaluation.

Ref. Chrysler PF 9825 2.3.1.2 Thermal Shock

5.3 Operating Random Vibration Test

Each amplifier shall be subjected to 2 hours per axis of the random vibration outlined below. Each unit should be powered @ 1/8th of the rated power (**3.2.3 Noise**) during the entire test.

Z - Axis

Breakpoint (Hz)	Magnitude (G²/Hz)
5	0.0055
10	0.059
60	0.035
200	0.0007
1000	0.00004

Total Spectral Content = 1.8 Grms

Y-Axis

Breakpoint (Hz)	Magnitude (G²/Hz)
5	0.0092
8	0.076
12	0.076
1000	0.0003

Total Spectral Content = 1.685 Grms

X-Axis

Breakpoint (Hz)	Magnitude (G²/Hz)
5	0.0054
10	0.0512
190	0.0027
370	0.00023
1000	0.00023

Total Spectral Content = 1.4 Grms

Post Test

Each amplifier shall be visually inspected for any loose or broken parts and components, followed by functional testing. No electrical or mechanical failure should occur during this test.

Ref. Chrysler PF 9825 2.3.2.1 Vibration

5.5 Operating Power (Noise) Test

Each speaker shall withstand 160 hours of application of noise signal specified in section 3.2.3. The noise signal should be calibrated to 100% of the RMS voltage rating as specified on the Product Specification. Leave the speakers for a minimum of 4 hours at room temperature before any post test evaluation is performed.

5.5 Operating Humidity

Each unit shall withstand exposure to 40°C, 90% minimum relative humidity for a total of 56 hours operating into the minimum specified load. During the first 48 hours, apply the designated noise (3.2.3 Noise) at 1/8 of the rated power. Then, for the last 8 hours, apply music, (3.2.2 Music) at rated power. Leave the unit for a minimum of 2 hours at room temperature before any post test evaluation.

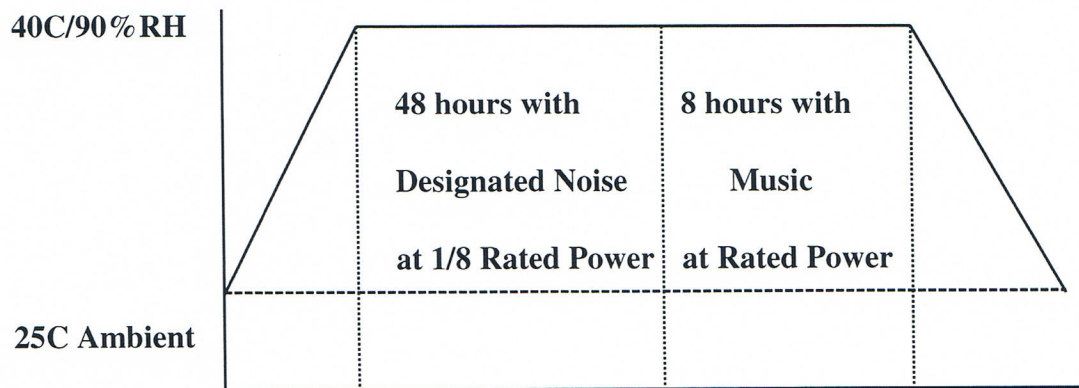

5.7 Temperature Storage (Non-operating)

Each amplifier shall withstand 24 hours of exposure to -40°C and 24 hours to 90°C inside the environmental chamber. The test duration should be 24 hours at each temperature with a minimum of 4 hours between temperature conditions. Leave the unit for a minimum of 2 hours at room temperature before any post-test evaluation. The amplifier should be tested at the end of each 24-hour period as needed.

Ref. Chrysler PF 9825

2.3.1.1 High/Low Temperature Soak

5.8 Drop/Mechanical Shock (Non-operating)

5.8.1 Limitation Drop

This test is for information only. There are no acceptance criteria. Each amplifier shall be dropped a total of 10 times (once due to 5.7.1 and nine times during this test) from a height of 1 meter on to concrete base. The impact locations are: Top left and lower right corners, the lower left and upper right edges, and all six faces (less the one done previously in 5.7.1).

5.9 Packaging Test (ASTM)

5.9.1 Schedule A—Manual Handling, First Sequence

For purposes of this procedure, the bottom of a small parcel is the surface on which the parcel rests in its most stable orientation. Recommended drop heights, the number of drops, the sequence of drops, and the shipping unit orientation at impact are as follows:

<u>Shipping Weight, lb (kg)</u>	<u>Drop Height, in. (mm)</u>
0 to 20 (0 to 9.1)	24 (610)
20 to 40 (9.1 to 18.1)	21 (533)
40 to 60 (18.1 to 27.2)	18 (457)
60 to 80 (27.2 to 36.3)	15 (381)
80 to 100 (36.3 to 45.4)	12 (305)
100 to 200 (45.4 to 90.7)	10 (254)

Number of Impacts At Specified Height	Impact Orientation –First Sequence of Distribution Cycle
One	top
Two	adjacent bottom edges
Two	diagonally opposite bottom corners
One	bottom

Ref: ASTM D 4169 - 99

5.9.2 Loose Load Vibration Method A1—Repetitive Shock Test

Place the test specimen on the test machine platform in its normal shipping orientation. Attach restraining devices to the platform to prevent the specimen from moving horizontally off the platform and to prevent excessive rocking without restricting the vertical movement. Adjust the restraining devices to permit free movement of the specimen of approximately 10 mm (0.4 in.) in any horizontal direction from its center position. Start the vibration of the platform at a frequency of about 2 Hz and steadily increase the frequency until some portion of the test specimen repeatedly leaves the test surface. To ensure that the test specimen receives a continuing series of repetitive shocks, a shim with a 1.6 mm (1 /16 -in.) thickness and a width of 50 mm (2.0 in.) shall be used to determine when the test specimen is leaving the test platform. The shim should be inserted under the package a minimum of 100 mm (4.0 in.) and moving it intermittently along one entire length of the package.

Continue the test at this frequency for a period of 1 hour. The test may be stopped momentarily to inspect for damage.

If the container might possibly be transported in any other orientations, test at least one container in each possible orientation for the full-specified test duration.

Inspect the container and its contents and record any damage or deterioration resulting from the test.

5.9.3 Schedule E-Vehicle Vibration

Perform the test for each possible shipping orientation. Recommended intensities and durations for the random tests are given below.

Random Test:

The following power spectral densities (as defined by their mode of transport, frequency and amplitude breakpoints) and test durations are recommended:

Air: Assurance Level I

<u>Frequency, Hz</u>	<u>Power Spectral Density Level, g² /Hz</u>
2	0.0004
12	0.02
100	0.02
300	0.00002
Overall, g rms	1.49
Duration, min ^B	180

^B For vehicle vibration tests in multiple shipping unit orientations, the total duration should be distributed evenly between the orientations tested.

Ref: ASTM D 4169 – 99

5.9.4 Schedule A–Manual Handling, Second Sequence

For purposes of this procedure, the bottom of a small parcel is the surface on which the parcel rests in its most stable orientation. Recommended drop heights, the number of drops, the sequence of drops, and the shipping unit orientation at impact are as follows:

<u>Shipping Weight, lb. (kg)</u>	<u>Drop Height, in. (mm)</u>
0 to 20 (0 to 9.1)	24 (610)
20 to 40 (9.1 to 18.1)	21 (533)
40 to 60 (18.1 to 27.2)	18 (457)
60 to 80 (27.2 to 36.3)	15 (381)
80 to 100 (36.3 to 45.4)	12 (305)
100 to 200 (45.4 to 90.7)	10 (254)

Number of Impacts At Specified Height	Impact Orientation –Second Sequence of Distribution Cycle
One	vertical edge
Two	adjacent side faces
Two	one top corner and one adjacent top edge
One	The drop should be in the impact orientation most likely for a drop to occur, usually the largest face or the bottom. For distribution cycles where any drop orientation is possible (i.e., small parcel environment), this drop should be in the most critical or damage-prone orientation.

5.10 Operating Voltage Range

The amplifier shall operate and perform all of its functions as specified when the supply voltage is varied between the operational voltage range specified in the Product Specification in maximum 0.5 V increments. The tolerance on the supply voltage is +/- 2%. Units will be tested from 10 to 15VDC for 30 minutes at each voltage level. The unit shall be calibrated to 1/8th rated power (**3.2.3** Noise) at a supply voltage of 14.4 VDC. The signal GND should be connected to the supply GND with a minimum wire thickness of 14 gauge.

5.11 Voltage Supply Extremes

There shall be no permanent damage to the amplifier and it shall operate as specified after being subjected to the following voltage extremes. The unit is to be operating at 14.4 VDC calibrated (**3.2.3** Noise) to 1 Watt. The fuse may blow during any of the test voltages, replace the fuse and continue with the next voltage test level (record the voltage level). The signal GND should be connected to the supply GND with a minimum wire thickness of 14 gauge.

<u>Voltage (Vdc)</u>	<u>Duration (Min.)</u>
(+) Nominal +20Volts	60
(+) Nominal +24Volts	1
(-) Nominal -16Volts	5
(-) Nominal -12.6Volts	1

- (+) **Positive Polarity**
- (-) **Reversed Polarity***

* The remote line should not be connected to any power source during the reversed polarity test.

Remote Line Extreme

Repeat section 5.11 and apply voltage to the Remote line. The reverse voltage test should not be performed on the remote line.

5.12 Shorted Output

A short is defined as an impedance of less than 0.1Ω, measured at test unit's output terminal. All shorts are applied with the amplifier system "off". The amplifier system is turned "on" in the presence of the short. The output power shall be set to max. into the specified load per Product Specification. Short test must be repeated for all channels.

- a. Short across output channel: No functional failure shall occur when unit is operated with a short across the amplifier for 2 minutes.
- b. Output channel leads to ground: No functional failure shall occur when unit is operated with a short across the amplifier for 2 minutes.
- c. Output channel leads to supply: No functional failure shall occur when unit is operated with a short across the amplifier for 2 minutes.

5.13 Load Dump

Each amplifier shall operate and perform all of its functions as specified in sec. 4.1 - 4.5.2 after conducting these tests. Total of 50 pulses, 3 Min. interval, must be applied for both positive and negative transient test. Test units should be tested for any catastrophic failures after applying 10th pulse.

5.13.1 Positive Transient

Using the test set-up shown in Fig. 4, a 10Ω load in place of the test unit and PSU1 should be adjusted to observe same waveform cross load resistor as shown in Fig. 5.

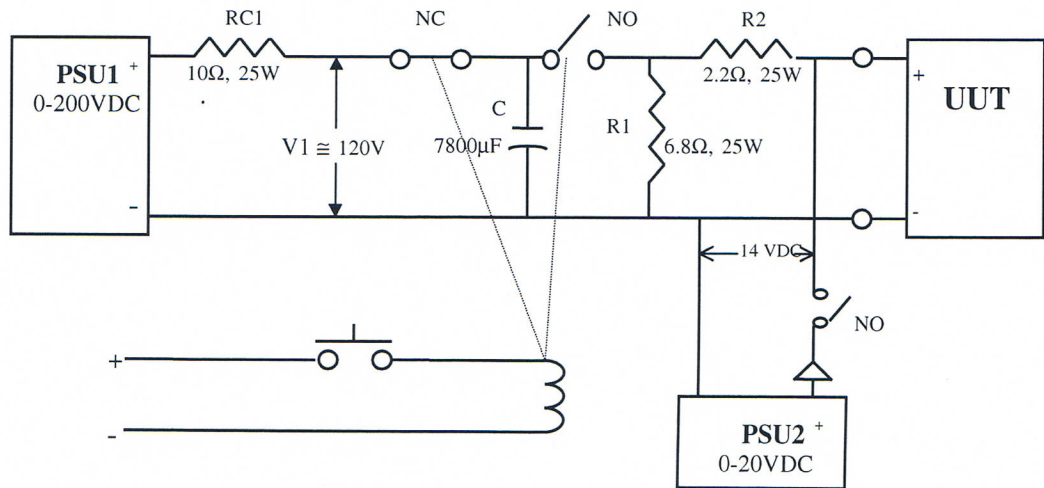

Fig. 4 Positive Transient Circuit

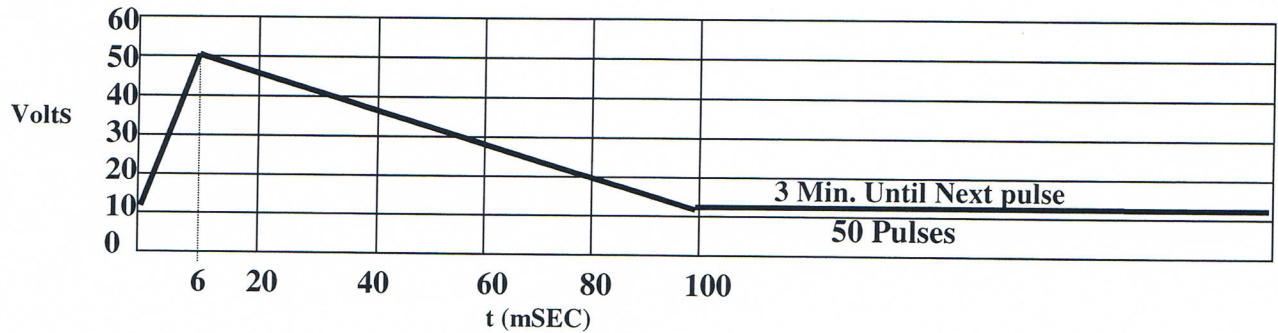

Fig. 5 Positive Transient waveform

5.13.2 Negative Transient

Using the test set-up shown in Fig. 6, a 10Ω load in place of the test unit and PSU1 should be adjusted to observe same waveform cross load resistor as shown in Fig. 5.

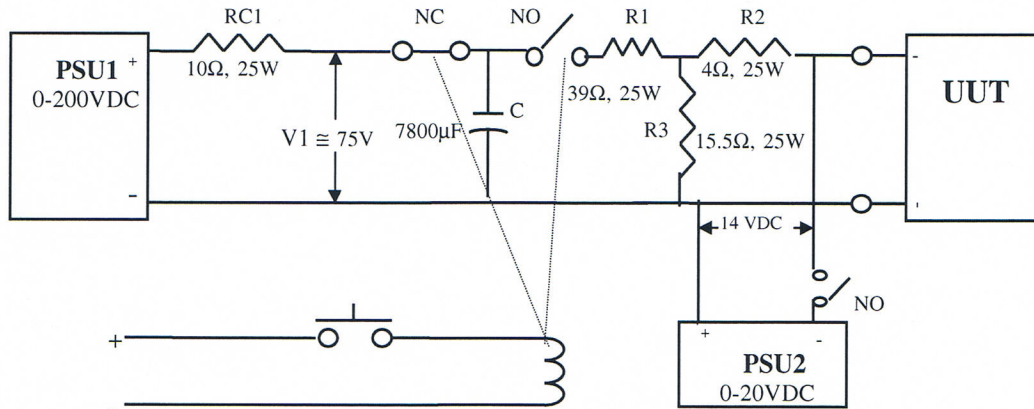

Fig. 6 Negative Transient Circuit

5.14 Electrostatic Discharge (ESD)

The amplifier shall be placed on a metallic ground plane with all the leads disconnected except the ground terminal and the case (if conductive) shall be connected via a low impedance path to the ground plane. Amplifier should be subjected to three discharges at each test voltage across an air gap to each connector pin with minimum of 5 Sec. between discharges. ESD Simulator should be set to 12.5KV, 50pf, 10K Ω for this test.

7.0 PRODUCT SPECIFICATION

<u>TEST PARAMETER</u>	<u>SECTION</u>	<u>UNIT</u>	<u>NOM</u>	<u>MIN</u>	<u>MAX</u>	<u>COMMENTS</u>
SUPPLY VOLTAGE/CURRENT	3.1	V/Amp				
Operating Voltage	3.1.1					
REFERENCE FREQUENCY	3.2.1	HZ				
OUTPUT LOAD (s)	3.3	Ω				
MEASUREMENT BANDWIDTH	3.4	HZ				
THD+N @ RATED PWR (NOM Load)	4.1	%				
Room Temp.						
Operating Temp.						
Operating Voltage						
THD+N @ RATED PWR (MIN Load)	4.1	%				
Room Temp.						
Operating Temp.						
Operating Voltage						
THD+N @ 1 WATT	4.2	%				
Room Temp.						
Operating Temp.						
Operating Voltage						
GAIN	4.3	dBr				
Room Temp.						
Operating Temp.						
Frequency Response	4.3.1					
Equalization & Filters	4.4	dBr				
Room Temp.						
Operating Temp.						
Noise Level	4.5	dBr				
Signal to Noise @ Full Power	4.5.1.1					
Signal to Noise @ 1 Watt	4.5.1.2					
INDUCED NOISE	4.5.2	mVrms				
CMRR	4.5.3	dBr				
CROSS TALK	4.6					
CURRENT DRAW	4.7	Amps				
TRANSIENT (ON/OFF)	4.8	Vrms				
Remote						
Room Temp.						
Operating Temp.						
Main						
Room Temp.						
Operating Temp.						