



DESCRIPTION

The PT2358 is a multiple inputs audio processor designed for Car Audio purpose. Using I²C interface controls all of the functions. Thanks for highly integration most of peripheral sub-circuits and components, it provides up to 9 inputs and equips outputs includes front, rear channel outputs. For highly enhanced audio performance and experience, PT2358 volume controller has Soft-Step function to eliminate click noise during volume step changes. Adjustable input gain, adaptive loudness, subwoofer filter, treble and bass tone control are all included.

APPLICATIONS

- Car Audio

FEATURES

- Operation voltage 6~10V
- 7 single-ended stereo Inputs
- 1 quasi-differential (QD) input for AUX
- 1 fully-differential (FD) input for Bluetooth® audio module.
- Input gain from 0 ~+15dB in 1dB step
- Main volume gain from +15 to -79dB in 1dB step with Soft-Step function.
- Soft-Mute and Soft-Step function for preventing audible click during volume and sources changing.
- 1 subwoofer output with 3-band crossover frequency selection and gain from +15 to -79dB in 1dB step
- Tone Control (Bass and Treble): -15 to +15dB in 1dB step
- Loudness: gain from 0 to -15dB in 1dB step
- Mixing input with 50% mixing ratio for front speakers, gain from -79 to +15dB in 1dB step.
- 4 independent outputs for front and rear speakers, output gain from +15 to -79dB with 1dB step
- Controlled by I²C Interface
- Low Distortion and Low Noise
- 48-pin LQFP package

BLOCK DIAGRAM

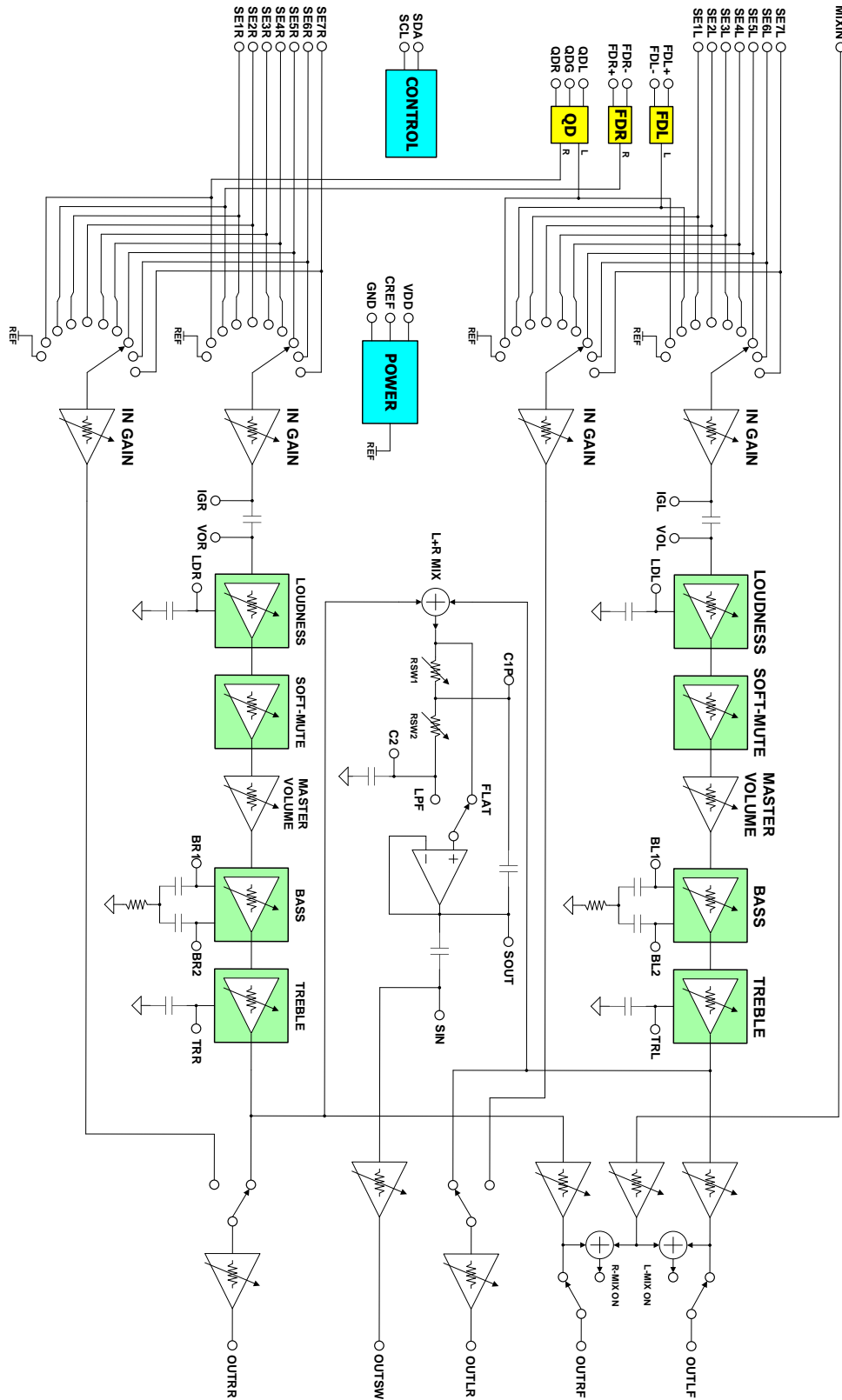

APPLICATION CIRCUIT

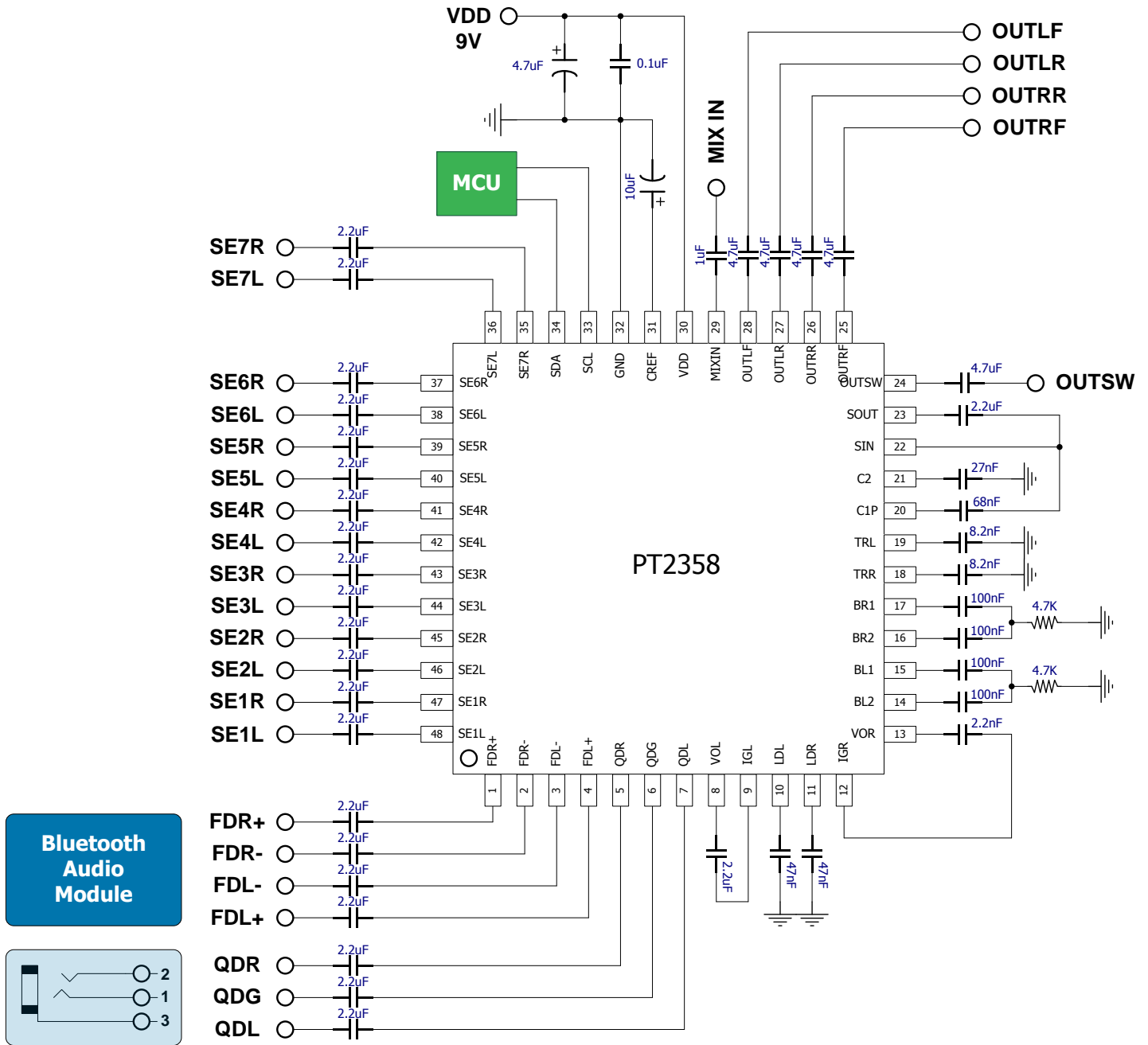



ORDER INFORMATION

Valid Part Number	Package Type	Top Code
PT2358	48-Pin, LQFP	PT2358-LQ

PIN CONFIGURATION

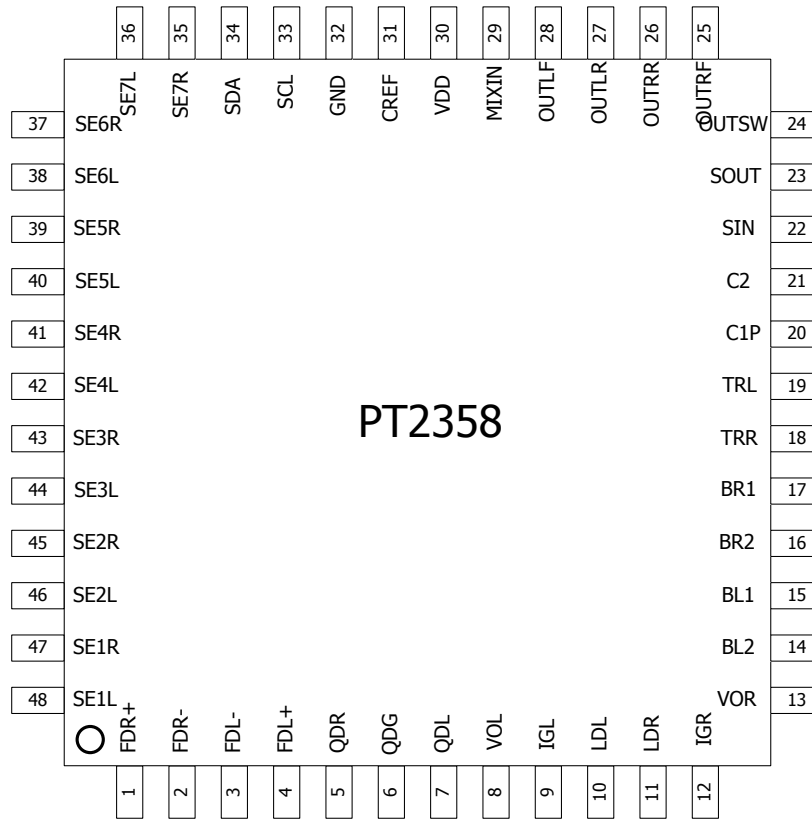

IMPORTANT NOTICE

Princeton Technology Corporation (PTC) reserves the right to make corrections, modifications, enhancements, improvements, and other changes to its products and to discontinue any product without notice at any time.

PTC cannot assume responsibility for use of any circuitry other than circuitry entirely embodied in a PTC product. No circuit patent licenses are implied.

Princeton Technology Corp.
2F, 233-1, Baociao Road,
Sindian Dist., New Taipei City 23145, Taiwan
Tel: 886-2-66296288
Fax: 886-2-29174598
<http://www.princeton.com.tw>