

 **USB Sound Card with PCM2902**

USB Sound Card with PCM2902

This is USB sound card with PCM2902 chip. For the purpose of testing the D / A converters, I built a simple USB sound card with the circuit PCM2902. The card has analog input and output, an electrical S / PDIF output, galvanically separated input and optical input and output TOSLINK. The heart of USB sound card is PCM2902 it is a circuit connection, which is a complete USB codec. The circuit can handle up to 48kHz sampling frequency. The integrated circuit includes a USB controller for A / D and D / A converter, HID part for 3 buttons, volume control, custom converters and S / PDIF encoder and decoder.

PCM2902 USB CODEC V1.1

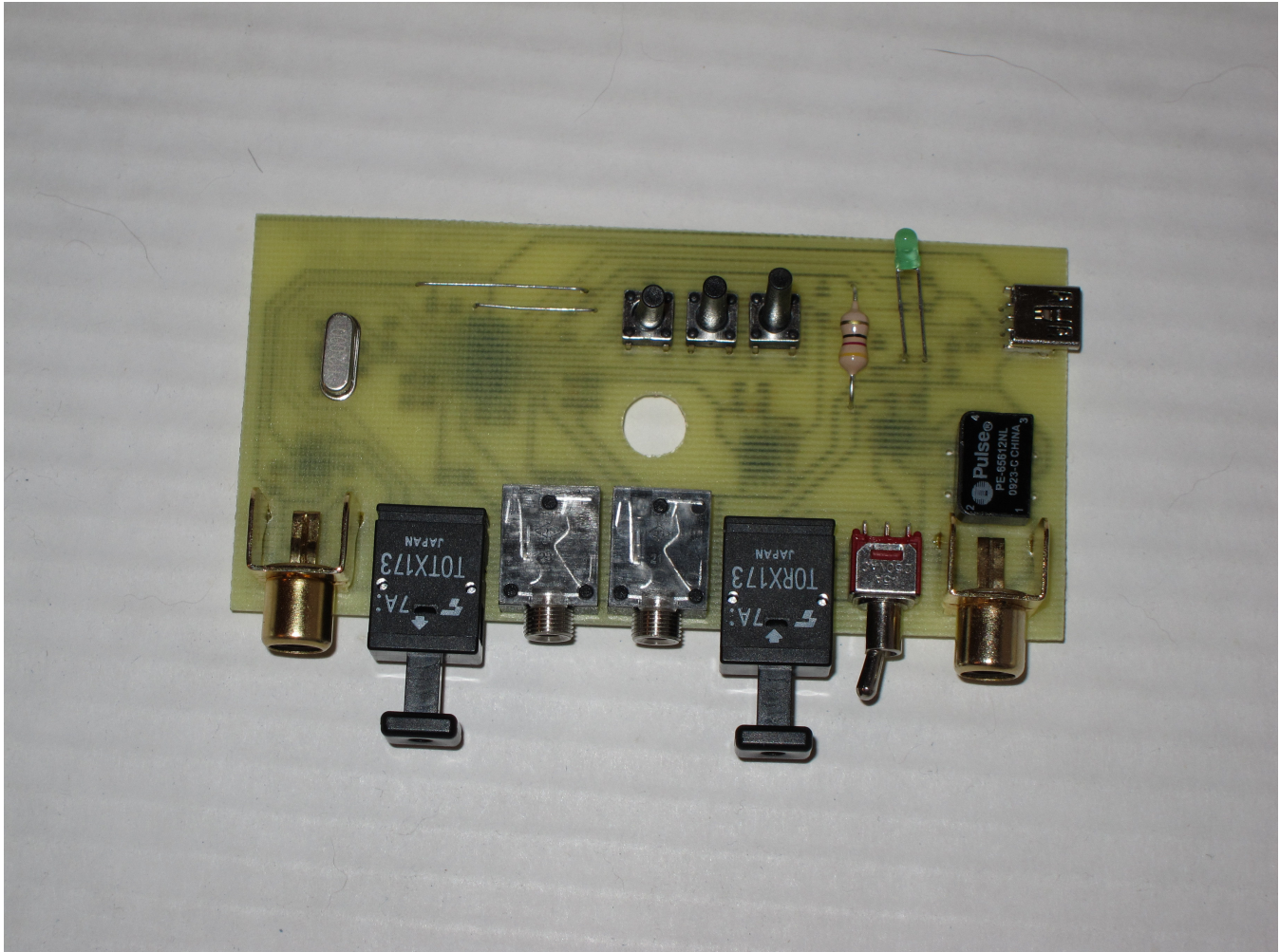
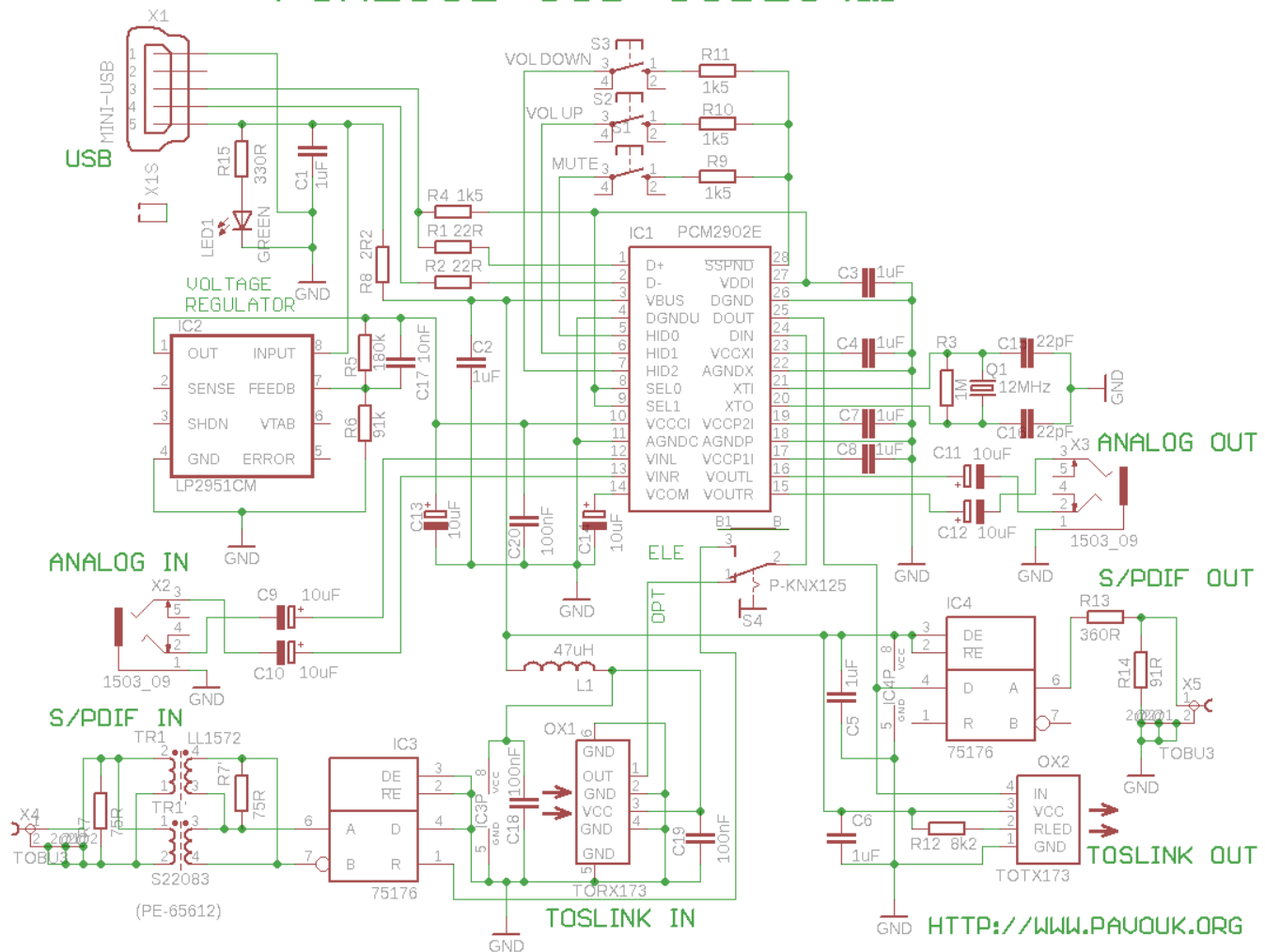

Involvement is based on the recommended involvement of the data sheet. For a better quality analog output is used with an external voltage regulator circuit IC2. All supply voltages are blocked 1uF capacitors. The circuit is also connected to an optical transmitter and receiver TOTX173 TORX173. Electrical S / PDIF output is realized using an RS422 transmitter IC4. Since the transfer of commercial S / PDIF coaxial cable used with unbalanced 75 ohm impedance, so I used only one output and using the resistive divider R13/R14 I shrunk the output voltage and adjust the output impedance standard. Most of the shows the output voltage of 0.6V peak-peak. The output divider is a little more tension, but it should not matter. S / PDIF receiver also includes an RS422 driver involved in reverse this time as to TTL converter. Entry is zaterminován resistor R7, which can be placed before, or pulse transformer. I had a better experience with a resistor before the transformer. Pulses on an oscilloscope look better. The digital input is connected via switch electrical / optics. The circuit automatically switches from an analog to digital, if you will detect the presence of S / PDIF signal. Analog output does not contain any external amplifier so you can not connect directly to such low impedance headphones. Expected to connect to an amplifier.

There is no need for special drivers. I tried the full functionality in Linux, Windows XP, Windows 7 Drivers are included with the operating system. They work well as HID buttons, volume control and mute.

Wiring

diagram format Eagle 5

Shouldering

We are placing PCB components from the smallest to largest. First I soldered circuit IC1, which is really quite small already. Circuit I snapped two corner pins mikropájkou. When I was sure that the circuit is properly positioned, so I nanesl on all pins liquid flux, which facilitates pouring tin and drove my soldering iron and tin cored first one side and then the other. Many outlets are fused together. Excess tin I was easily suctioned copper wick, which is sold for this purpose. Next I soldered the other circuits and I continued SMD resistors and capacitors. Then I placed a jumper wire, and all parts of the upper side and end connectors.

Placement Plan

PCB

PCB is designed as a one-sided with two wire jumpers. This allows us to its easy production in amateur conditions. Its dimensions correspond to a plastic box U-KP35B. After assembly, I discovered that the switch inputs is connected backwards. Here is a link already repaired. SMD components have a size 1206 and are positioned so that the well-soldered.

PDF format Eagle5

Photo

Component

Most of the parts I got in GM Electronic. USB connector GES Electronic and IC PCM2902 sell such as FK Technics. Pulse transformer I got on Ebay and specifically PE-65612th If we do not mind that the input is not isolated, it can be replaced by two 100nF capacitors.

List of components

designation value and type number

R1-R2 SMD1206 22R 2pcs

R3 1M SMD1206 1pc

R4, R9-R11 SMD1206 1K5 4pcs

R5 180km SMD1206 1pc

R6 91k SMD1206 1pc

R7 SMD1206 75R 1pc

R8 2R2 SMD1206 1pc

R12 SMD1206 8K2 1pc

R13 SMD1206 360R 1pc
R14 SMD1206 91R 1pc
R15 SMD1206 330R 1pc
C1-C8 1uF Ceramic SMD1206 8pcs
C9-C14 10uF/25V electrolyte SMD size B 6pcs
C15-C16 22pF Ceramic SMD1206 2pcs
C17 10nF Ceramic SMD1206 1pc
C18-C20 100nF Ceramic SMD1206 3pcs
IC1 PCM2902, PCM2902B 1pc
IC2 LP2951CM SMD SO-08 1pc
IC3-IC4 75176B SMD SO-08 2pcs
L1 47uH axial 1pc
LED1 2 mA LED green 1pc
OX1 TORX173 toshiba 1pc
OX2 TOTX173 toshiba 1pc
Q1 12MHz crystal mini 1pc
S1-S3 microswitch 6x6mm high 3pcs
S4 P-Switch KNX125 1pc
TR1 LL1572 or S22083, or PE-65612 1pc
X1 USB miniUSB socket PCB MBW 1pc
X2-X3 3.5 "jack EBS35 2pcs
X4-X5 RCA jack PCB TOBU3 2pcs
Krab1 Plastic Box U-23 mm x 54mm KP35B x 104 mm 1pc

Conclusion

Uvedené connection works reliably. Measured parameters approximately correspond to those in the data sheet. If you want to use just some of the inputs or outputs, it is not necessary to assemble all the connectors. In addition to the circuit PCM2902 are expensive optical transceivers and transformers. Wiring can be used as a second sound card, or as S / PDIF output to a stereo amplifier with digital input. The digital input can be used to connect other digital audio sources such as DAT, MiniDisc, CD player, etc. parameters measurement programs I conducted RightMark Audio Analyzer (RMAA) and Baudline. With RMAA for some reason, I reached under Windows 7 much worse than under Windows XP. Also there worked odd volume control. I also dealt with testing only under Linux.

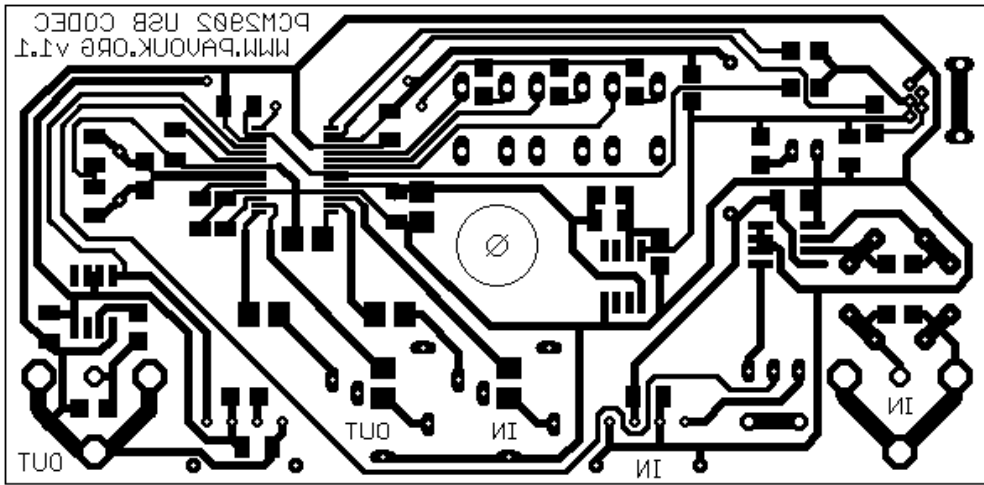
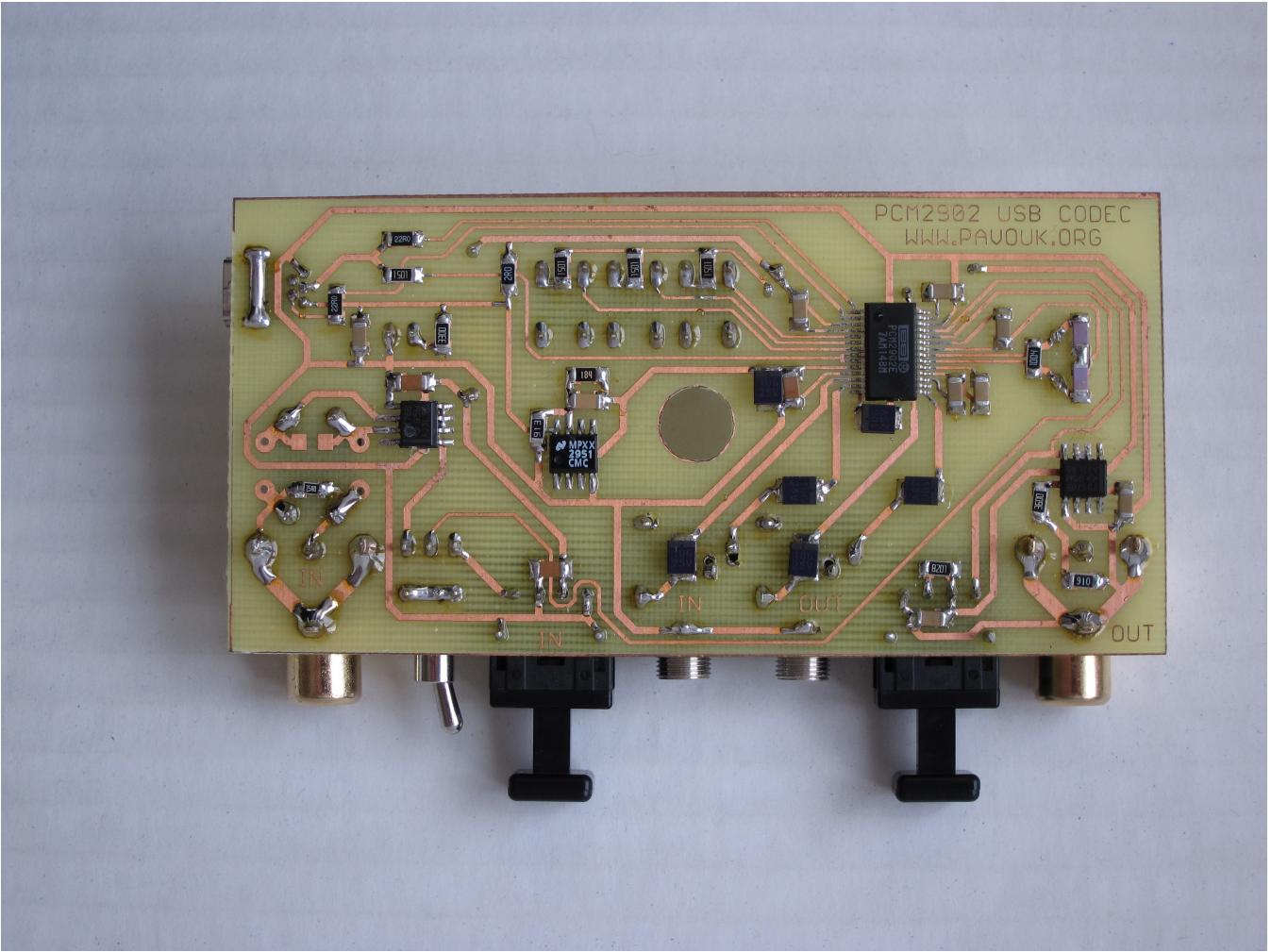

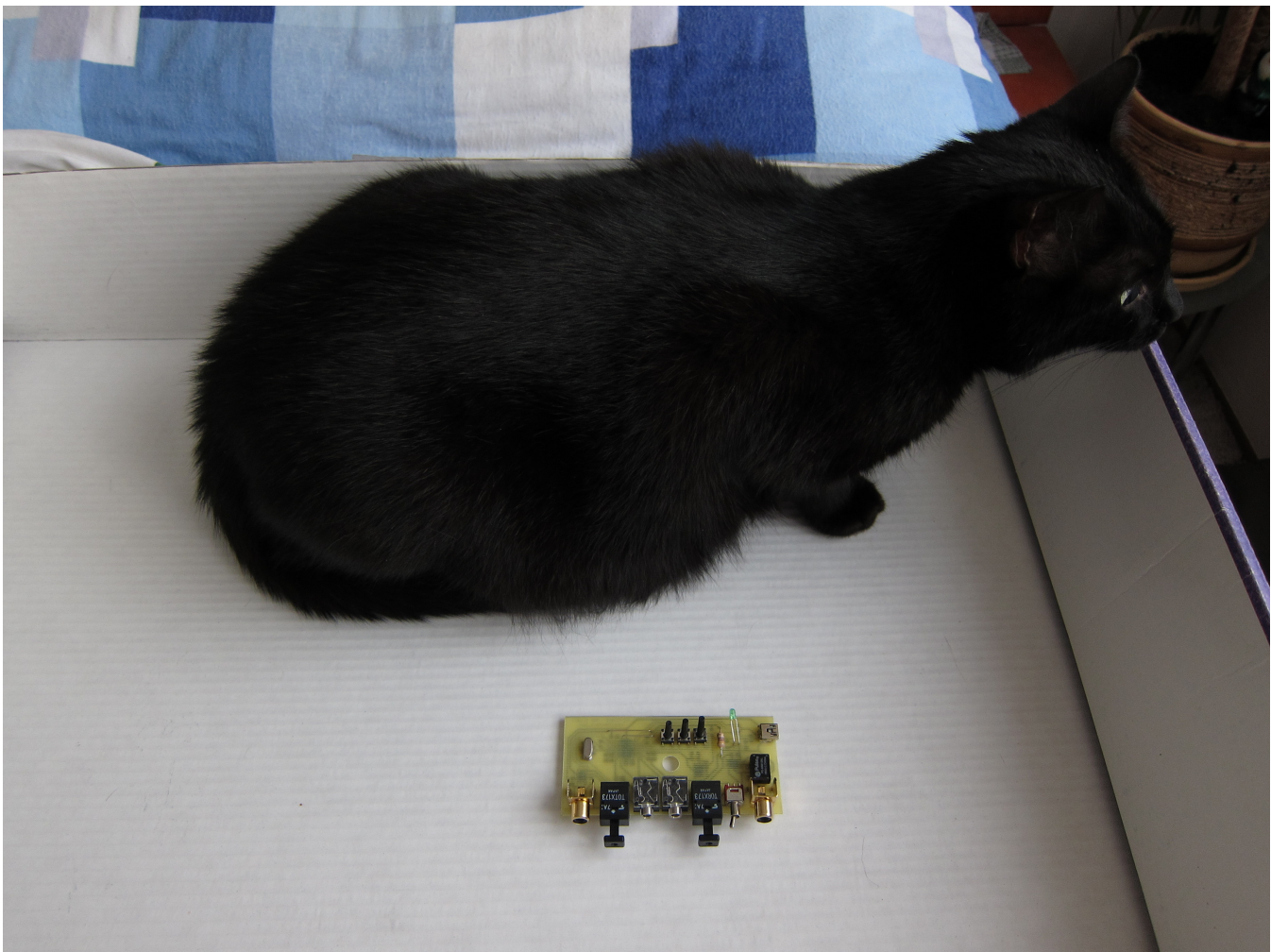
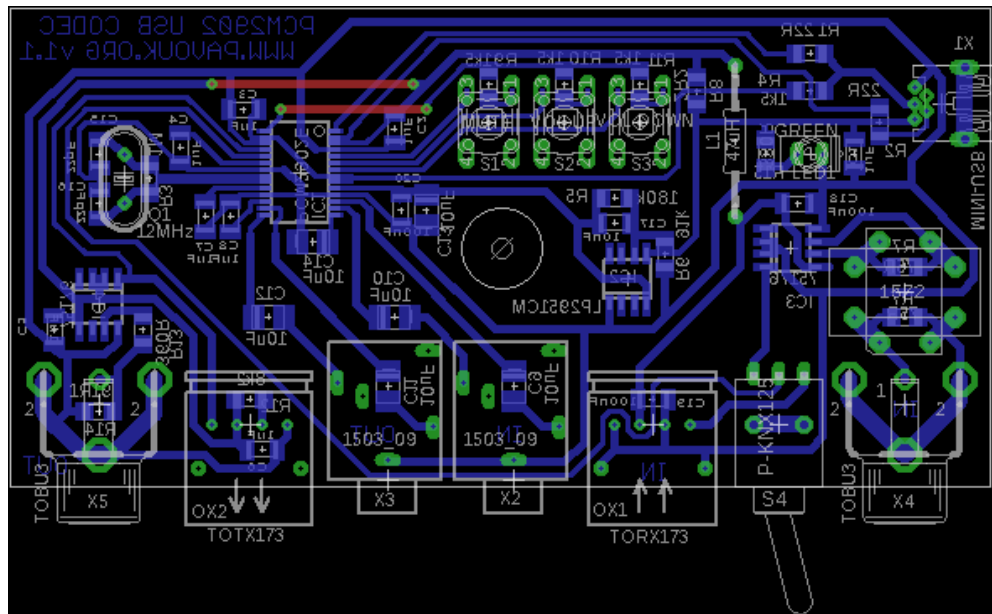

Related Links

- [Accurate LC Meter](#)
- [60MHz Frequency Meter / Counter](#)
- [PIC Volt Ampere Meter](#)

- 1Hz - 2MHz Function Generator
- Accurate 0-500MHz RF Power Meter
- PIC Dual Temperature Meter
- BA1404 HI-FI Stereo FM Transmitter
- BH1417 Stereo PLL FM Transmitter
- 500mW FM / VHF Transmitter Amplifier / Booster
- 50mW BH1417 Stereo PLL FM Transmitter
- Phone FM Transmitter
- TV Transmitter with Audio
- 5 Watt FM Amplifier
- TDA7000 FM Receiver / TV Tuner / Aircraft Receiver
- NJM2035 HI-FI Stereo Encoder / Multiplexer
- USB Voltmeter
- USB IO Board

Downloads

USB Sound Card with PCM2902 - Link

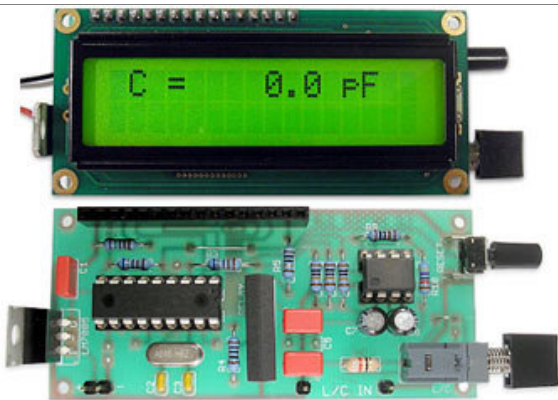

Accurate LC Meter

Build your own Accurate LC Meter (Capacitance Inductance Meter) and start making your own coils and inductors. This LC Meter allows to measure incredibly small inductances making it perfect tool for making all types of RF coils and inductors. LC Meter can measure inductances starting from 10nH - 1000nH, 1uH - 1000uH, 1mH - 100mH and capacitances from 0.1pF up to 900nF. The circuit includes an auto ranging as well as reset switch and produces very accurate and stable readings.

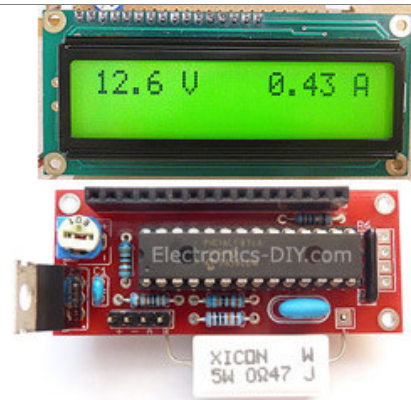

PIC Volt Ampere Meter

Volt Ampere Meter measures voltage of 0-70V or 0-500V with 100mV resolution and current consumption 0-10A or more with 10mA resolution. The meter is a perfect addition to any power supply, battery chargers and other electronic projects where voltage and current must be monitored. The meter uses PIC16F876A microcontroller with 16x2 backlighted LCD.



60MHz Frequency Meter / Counter

Frequency Meter / Counter measures frequency from 10Hz to 60MHz with 10Hz resolution. It is a very useful bench test equipment for testing and finding out the frequency of various devices with unknown frequency such as oscillators, radio receivers, transmitters, function generators, crystals, etc.

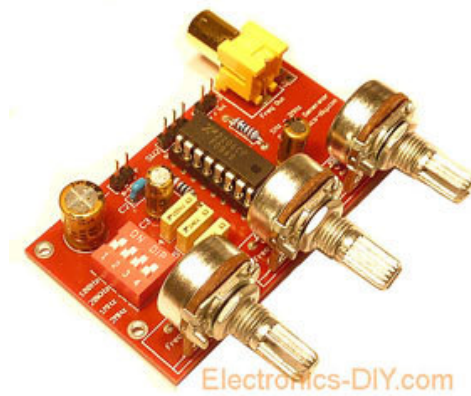

1Hz - 2MHz XR2206 Function Generator

1Hz - 2MHz XR2206 Function Generator produces high quality sine, square and triangle waveforms of high-stability and accuracy. The output waveforms can be both amplitude and frequency modulated. Output of 1Hz - 2MHz XR2206 Function Generator can be connected directly to 60MHz Counter for setting precise frequency output.



BA1404 HI-FI Stereo FM Transmitter

Be "On Air" with your own radio station! BA1404 HI-FI Stereo FM Transmitter broadcasts high quality stereo signal in 88MHz - 108MHz FM band. It can be connected to any type of stereo audio source such as iPod, Computer, Laptop, CD Player, Walkman, Television, Satellite Receiver, Tape Deck or other stereo system to transmit stereo sound with excellent clarity throughout your home, office, yard or camp ground.

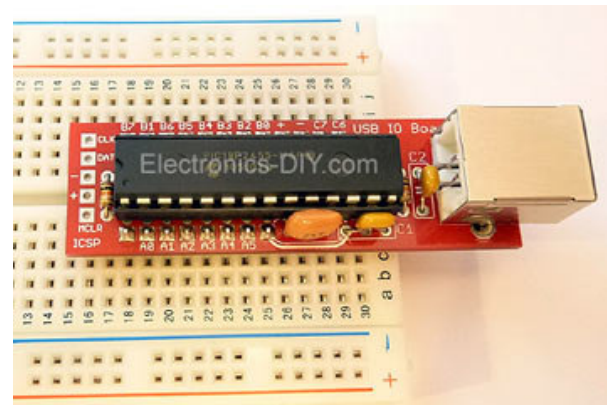

USB IO Board

USB IO Board is a tiny spectacular little development board / parallel port replacement featuring PIC18F2455/PIC18F2550 microcontroller. USB IO Board is compatible with Windows / Mac OSX / Linux computers. When attached to Windows IO board will show up as RS232 COM port. You can control 16 individual microcontroller I/O pins by sending simple serial commands. USB IO Board is self-powered by USB port and can provide up to 500mA for electronic projects. USB IO Board is breadboard compatible.

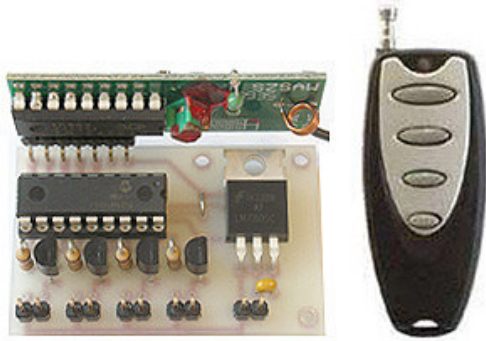

200m 4-Channel 433MHz Wireless RF Remote Control

Having the ability to control various appliances inside or outside of your house wirelessly is a huge convenience, and can make your life much easier and fun. RF remote control provides long range of up to 200m / 650ft and can find many uses for controlling different devices, and it works even through the walls. You can control lights, fans, AC system, computer, printer, amplifier, robots, garage door, security systems, motor-driven curtains, motorized window blinds, door locks, sprinklers, motorized projection screens and anything else you can think of.

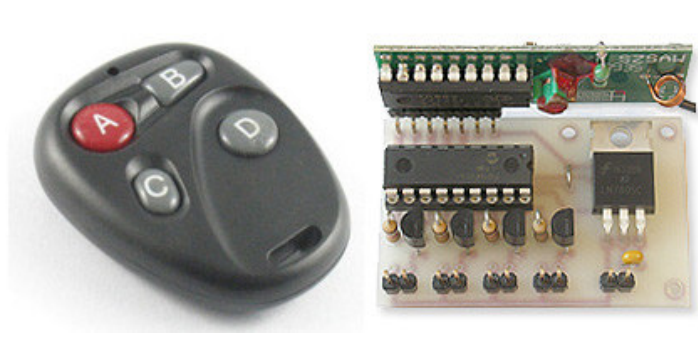

100m 4-Channel 433MHz Wireless RF Remote Control

Four button RF remote is used to turn ON / OFF four different devices independently. Any of the four outputs can be configured to work independently in either toggle or momentary mode. Outputs are buffered by BC549 NPN transistors and can drive low voltage devices directly or be connected to either 5V or 12V relays (or motors) to control appliances that use 110V / 220V mains voltage or any voltage of your choice. Multiple remote systems can be used independently to control more than four appliances in the same location by changing the address code on 433MHz receiver and remote. It is also possible to use several remotes to control the same appliance such as garage door.

Electronics-DIY.com © 2002-2011. All Rights Reserved.