

designideas

READERS SOLVE DESIGN PROBLEMS

Audio equalizer features transimpedance Q-enhancement topology

Hermínio Martínez, Encarna García, and Eva Vidal,
Technical University of Catalonia, Barcelona, Spain

In general, audio equalizers need second-order bandpass filters. Such cells require an easy and independent tuning of their parameters: the natural or central frequency, ω_0 ; the quality factor, Q ; and the maximum bandpass gain, k . The use of cells with independent adjustments could require state-variable topologies. Unfortunately, this sort of structure usually needs at least three operational amplifiers. The basis for an alternative uses SAB (single-amplifier-biquadratic) filters. These cells allow obtaining second-order bandpass filters, but they have two main drawbacks: The quality factors that you can obtain with these cells have a practical maximum limit, and you cannot independently tune the three characteristic parameters.

This Design Idea instead uses the TQE (transimpedance-Q-enhancement) structure in an audio-equalizer

(Figure 1). This cell has two advantages when you use it in equalizer circuits: You can adjust the three characteristic parameters in an independent way, but it uses only two operational amplifiers per cell. Reference 1 presents the generic TQE topology. Figure 1 shows the configuration that implements a bandpass filter based on the generic structure. This structure, which processes current-input signals, shows low-impedance input without the resistor R_{IN} . Considering that R_1 and R_3 are equal in value and that all the capacitors are equal to C , the transimpedance, $Z(s)$, is:

$$Z(s) = \frac{V_{BP}(s)}{I_{IN}(s)} = \frac{R_1^2 C s}{R_1^2 C^2 s^2 + (2 - R_1/R_2) R_1 C s + 1}$$

However, by adding R_{IN} , the in-

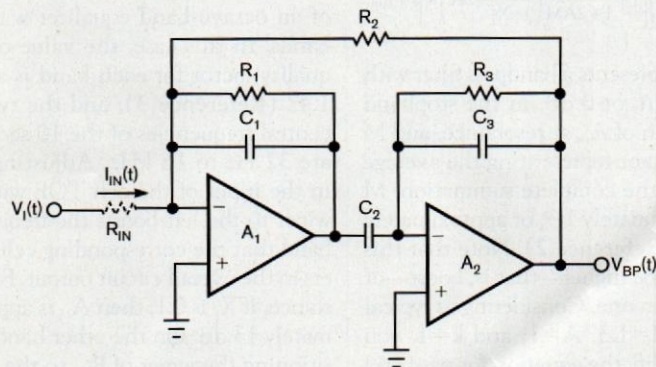

Figure 1 Adding R_{IN} to this bandpass filter based on a TQE structure causes the circuit to show high input impedance.

DI Inside

66 AMI-to-NRZI-direct-conversion circuit tolerates unequalized pulse tails

70 Virtual RF generator measures load impedance and power

► What are your design problems and solutions? Publish them here and receive \$150! Send your Design Ideas to edndesignideas@reedbusiness.com.

put has high impedance, allowing the processing of voltage input signals because R_{IN} provides the required voltage-to-current conversion. In this way, the input-to-output transfer function, $H(s)$, is:

$$H(s) = \frac{V_{BP}(s)}{V_1(s)} = \frac{R_1}{R_{IN}} \frac{s/R_1 C}{s^2 + s(2 - R_1/R_2)/R_1 C + 1/R_1^2 C^2}$$

Thus, the circuit implements a second-order bandpass-transfer function; the following equations yield the central frequency, ω_0 , and the quality factor, Q :

$$\omega_0 = 1/R_1 C; Q = \frac{R_2}{2R_2 - R_1}$$

and the value of the gain, k , is:

$$k = \frac{R_1}{R_{IN}} Q = \frac{R_1}{R_{IN}} \left(\frac{R_2}{2R_2 - R_1} \right)$$

Thus, you can make the adjustments of ω_0 , Q , and k with R_1 , R_2 , and R_{IN} , respectively.

You can use the bandpass cell in Figure 1 in an audio equalizer. Figure 2 shows a possible implementation of a

graphic equalizer. The basis for the circuit is a bank of bandpass TQE cells. Note that the cells are TQE with low-impedance input. Thus, the input network's R_{IN} converts $V_{IN}(t)$ and $V_{OUT}(t)$ to the corresponding input current, $I_{IN}(t)$. Adjusting potentiometer R_{IN} with its wiper to the far left ($X_1 \rightarrow 0$) accentuates the frequency band that the corresponding cell covers in the overall circuit output. On the other hand, positioning the wiper of R_{IN} to the far right ($X_1 \rightarrow 1$) causes a large amount of negative feedback to occur at this same frequency, thus causing attenuation in the forward-signal path. In each case, the remaining filters' TQE₁ receives percentages of both the input signal, $V_{IN}(t)$, and the output signal, $V_{OUT}(t)$, in ratios that their respective potentiometer settings determine.

You can derive the overall transfer function from **Figure 2**. The output voltage, $V_{OUT}(s)$, of the equalizer is:

$$V_{OUT}(s) = - \left[V_{IN}(s) + A \sum_{I=1}^N Z_I(s) \left[\frac{V_{IN}(s)}{X_I R_{IN}} + \frac{V_{OUT}(s)}{(1-X_I)R_{IN}} \right] \right]$$

where $Z_I(s)$ are the cells' transimpedances, and

$$A = \frac{R_B}{R_A}$$

If you define

$$H_I(s) = Z_I(s)/R_{IN}$$

then the transfer function of the equalizer becomes

$$\frac{V_{OUT}(s)}{V_{IN}(s)} = \frac{1 + A \sum_{I=1}^N \frac{H_I(s)}{X_I}}{1 + A \sum_{I=1}^N \frac{H_I(s)}{1-X_I}}$$

Now, you can investigate the effect of various settings of the potentiometers. For example, in the case with all of the controls centered, X_1 equals 0.5 for each band. Then, $V_{OUT}(s)/V_{IN}(s) = -1$, as you would expect in a typical equalizer's response. Setting band $I=1$ to a value of X_1 and all other bands flat—that is, $X_1=0.5$ for $I=2, 3, \dots, n$), you obtain:

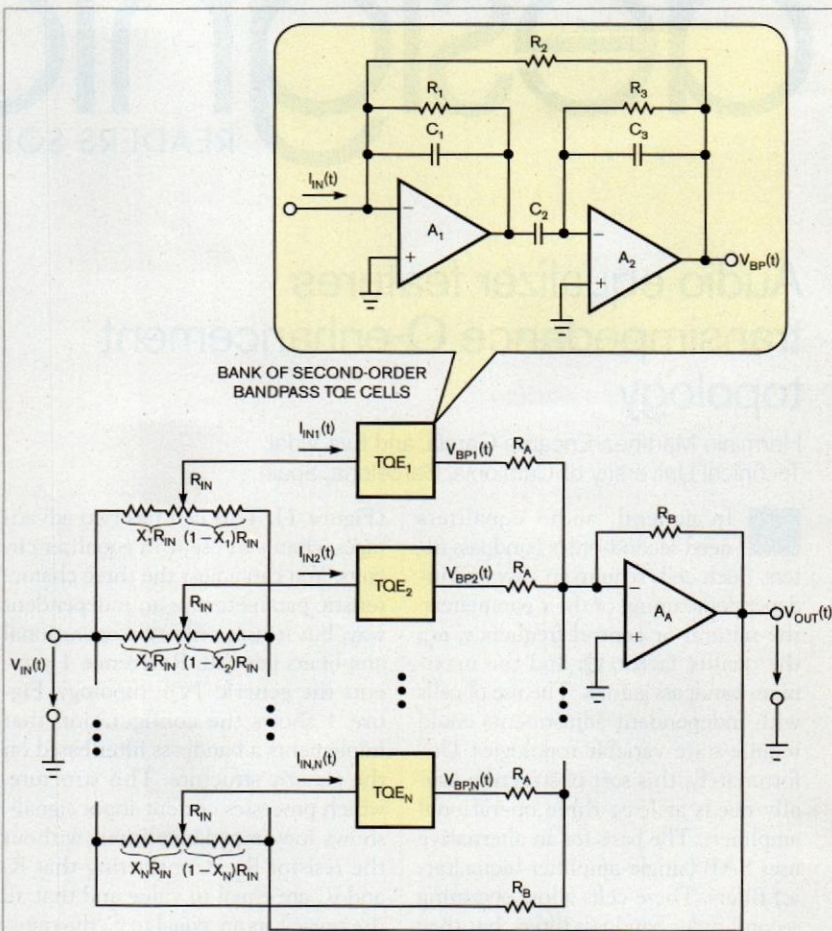

Figure 2 The TQE cells in this graphic equalizer have low-impedance inputs.

$$\frac{V_{OUT}(s)}{V_{IN}(s)} = \frac{s^2 + \left(\frac{\omega_{01}}{Q_1}\right) \left[1 + \frac{1}{1+2AM} \left(\frac{A}{X_1} - 2A \right) k \right] s + \omega_{01}^2}{s^2 + \left(\frac{\omega_{01}}{Q_1}\right) \left[1 + \frac{1}{1+2AM} \left(\frac{A}{1-X_1} - 2A \right) k \right] s + \omega_{01}^2}$$

which represents a bandpass filter with unity gain, or 0 dB, in the stopband and a gain of A_0 at resonance, and M is a constant representing the average value of the complete summation. M is approximately 1.3, or approximately 2.3 dB (Reference 2). Note that this gain can be higher—that is, boost—or lower than one. Considering as typical values $M=1.3$, $A=1$, and $k=1$, you can simplify the equation for passband gain A_0 , which is equal to the ratio of the s term coefficients, as:

$$A_0 = \frac{3.6 + \left(\frac{1-2X_1}{X_1} \right)}{3.6 + \left[\frac{1-2(1-X_1)}{1-X_1} \right]}$$

As an example, consider the case of an octave-band equalizer with 10 bands. In this case, the value of the quality factor for each band is about 1.42 (Reference 3), and the typical central frequencies of the 10 sections are 32 Hz to 16 kHz. Adjusting R_{IN} in the input of the cell TQE with its wiper to the left boosts the frequency band that the corresponding cell covers in the overall circuit output. For instance, if X_1 is 0.1, then A_0 is approximately 13 dB. On the other hand, positioning the wiper of R_{IN} to the right causes attenuation in the forward-signal path. So, if X_1 is 0.9, then A_0 is

designideas

approximately -13 dB. You must have a minimum input impedance in each cell for the input voltage, $V_{IN}(t)$, and the feedback voltage, $V_{OUT}(t)$. Thus, the inclusion of two resistors in series with each potentiometer R_{IN} in **Figure 2** guarantees this resistance. **EDN**

REFERENCES

1 Carlosena, Alfonso, and Eusebio

Cabral, "Novel Transimpedance Filter Topology for Instrumentation," *IEEE Transactions on Instrumentation and Measurement*, Volume 46, No. 4, pg 862, August 1997, http://ieeexplore.ieee.org/xpl/freeabs_all.jsp?tp=&arnumber=650789&isnumber=14201.

2 Greiner, RA, and Michael Schoesow, "Design Aspects of Graphic

Equalizers," *Journal of the Audio Engineering Society*, Volume 31, No. 6, pg 394, June 1983, www.aes.org/e-lib/browse.cfm?elib=4574.

3 Bohn, Dennis A, "Constant-Q Graphic Equalizers," *Journal of the Audio Engineering Society*, Volume 34, No. 9, September 1986, www.rane.com/pdf/constanq.pdf.