



# Light Theremin

Written By: Steve Hobley

## PARTS:

- [Resistor \(1\)](#)  
*from RadioShack. Available in the parts drawers at your local RadioShack. Plenty of resistors for future projects!*
- [Hookup wire \(1\)](#)  
*from RadioShack.*
- [Breadboard \(1\)](#)  
*from RadioShack.*
- [Capacitor 0.22 F \(2\)](#)  
*from RadioShack. You can also use one 0.47 F instead of two .22 F caps in parallel.*
- [Electrolytic Capacitor 100 \$\mu\$ F \(1\)](#)  
*from RadioShack.*
- [Speaker \(1\)](#)  
*from RadioShack.*
- [Photoresistor \(1\)](#)  
*from RadioShack. You can also try using photodiodes, too. Experiment.*
- [Battery holder, 4xAA \(1\)](#)  
*from RadioShack. Use this or other means of delivering 6v to the finished circuit.*
- [555 timer IC from RadioShack \(1\)](#)

## SUMMARY

Anyone who's shivered in the dark at a scary movie or laughed at the unintentional cheese-ball of a bad sci-fi (paging Ed Wood) knows the eerie sounds of the theremin. In the classic theremin design, two antennas control pitch and volume, and you play the instrument by moving your hands near the antennas without touching them.

This simpler design uses interrupted photons (light) instead of radio waves, and can be built with a handful of common components, including the versatile 555 timer chip. When we're done, we'll have a decent sounding mini-theremin. You can experiment with its sound by changing the type of light sensor used and the capacitance of the circuit.

Check out more [Weekend Projects](#).

### Step 1 — Gather Your Parts

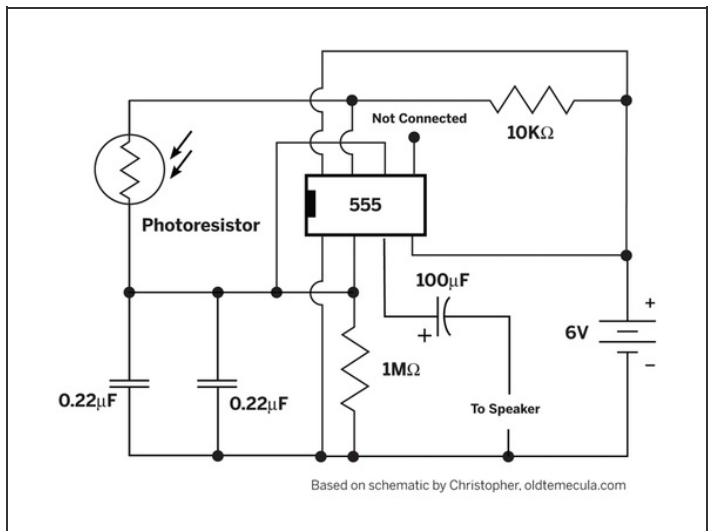
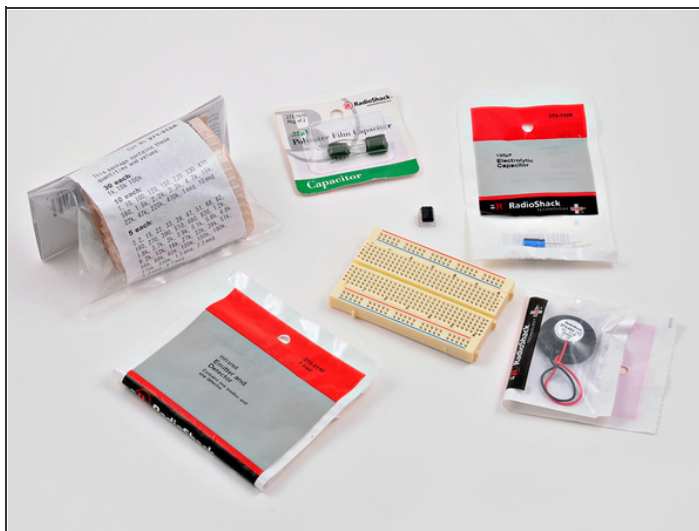

- Gather together the breadboard, capacitors, speaker, resistors and photoresistor (or photodiodes).
- TIP: I nearly always buy the large multi-packs of resistors; it saves time and money in the long run.
- The schematic I based this project on called for a 0.47 F capacitor. I didn't have any, so I used two 0.22 F capacitors in parallel. The values add, giving 0.44 F -- and that's close enough!
- We are going to be building a 555 timer-based "astable oscillator circuit." It sounds complicated, but really, it's not that hard.

## Step 2 — Install the 555 Chip and Power Lines

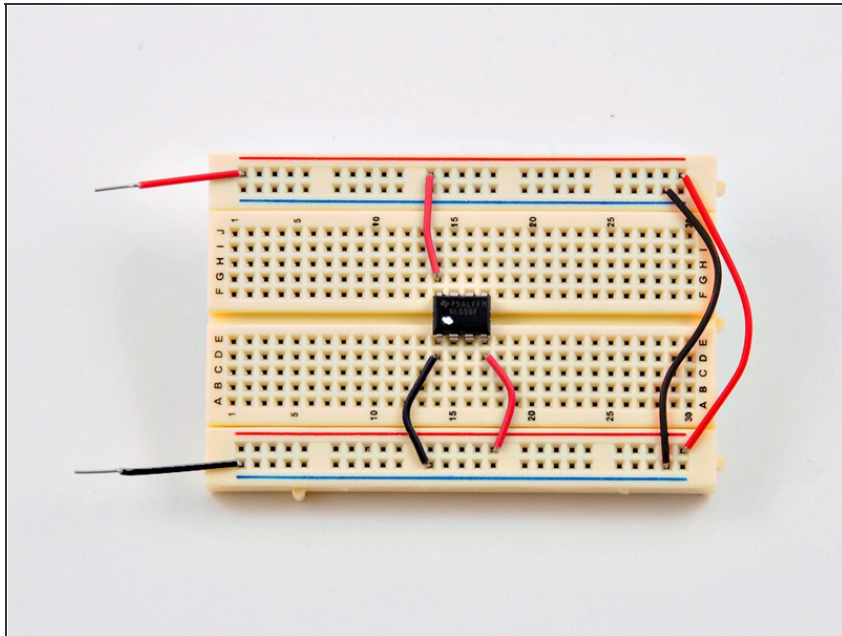

- Our first task is to place the 555 timer IC on the breadboard. Note the location of the small dot indentation (which I painted white to make it more visible). That dot always marks Pin 1 on a chip.
- I also added the basic power lines — red is +6v, and black is 0v (Gnd).
- The two red wires carry the power lines between the top and bottom horizontal power "rails" on the breadboard.

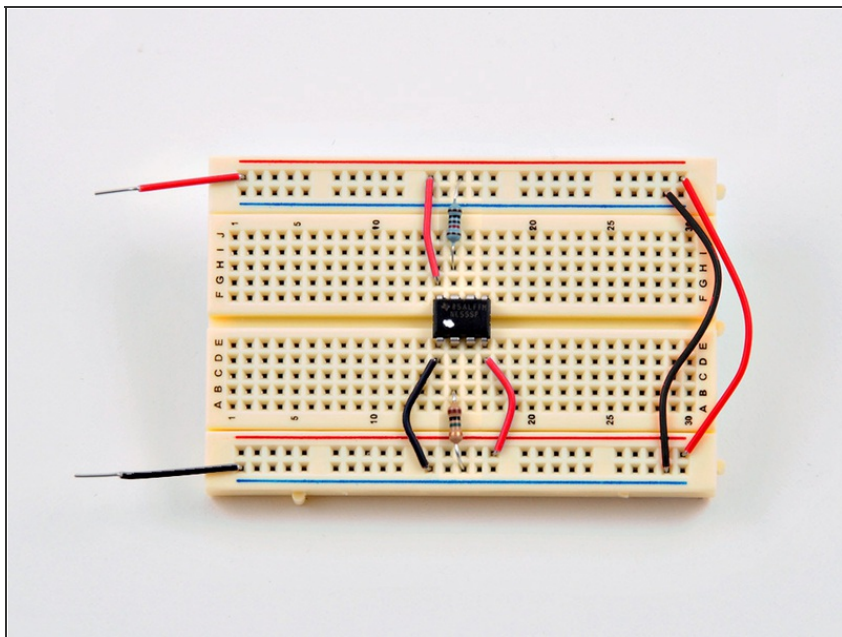

## Step 3 — Install the Resistors

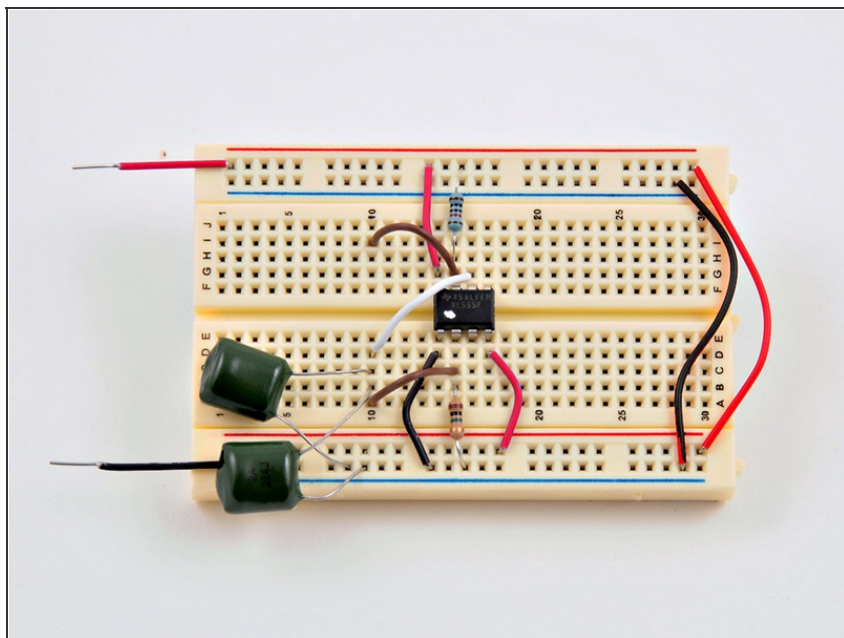

- Breadboard the 10KΩ (Brown, Black, Orange, Gold) resistor at the top, and the 1MΩ (Brown, Black, Green, Gold) resistor at the bottom, as shown.
- Disregard the blue color of the 10KΩ here; your resistor will likely be beige in color. 

## Step 4 — Add the Capacitors



- Add both 0.22 F capacitors in parallel.
- Be careful that the legs of the capacitors do not touch! 
- Remember: I'm using two .22 F caps in place of the .47 F called for in the schematic.  If you have a .47 F cap, you can use that.
- Also add support wires as shown (the two brown wires, and one white one).

## Step 5 — Install the Remainder of the Parts

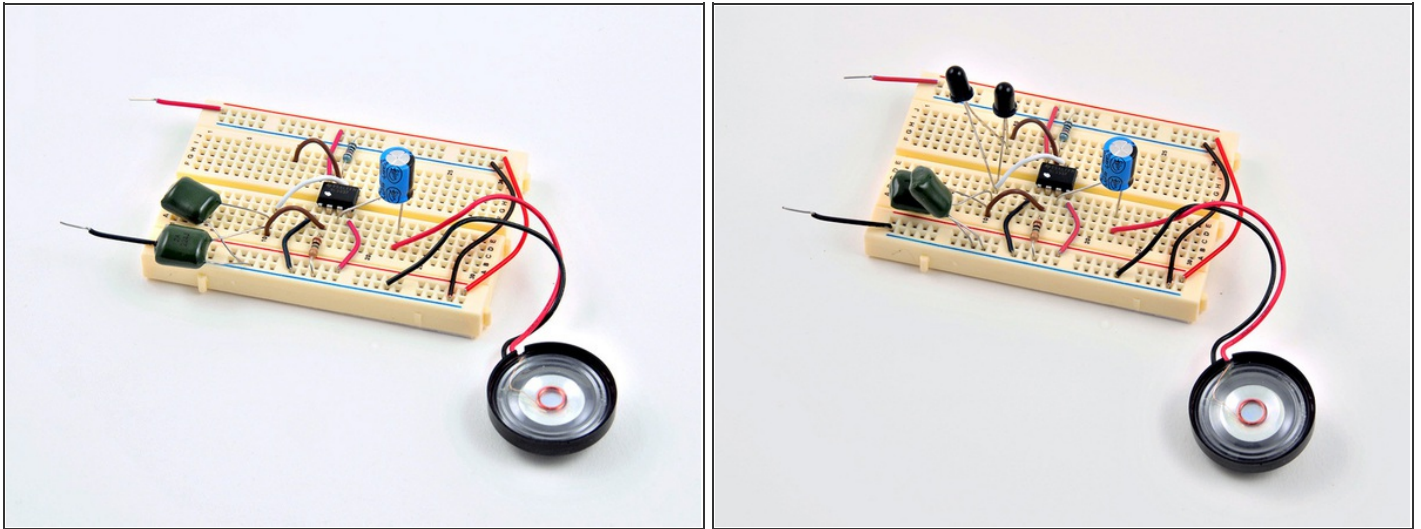

- Add the 100  $\mu$ F electrolytic capacitor.
- Note: Electrolytic capacitors are polarity-sensitive. They can only safely go in one way. Note the orientation of the black band; it marks the negative lead. 
- Add the speaker. Note the orientation of the red (+) and black (-) wires; it also needs to be connected with the correct polarity.
- Install the two photodiodes (second image).
- You should now be able to power up the device and hear a buzzing tone coming from the speaker. Move your fingers towards the photodiodes, and the pitch should go down.
- That's it! Move your fingers around the photodiodes to create different notes and sound effects.



## Step 6 — Experiment: Photodiodes vs. Photoresistors

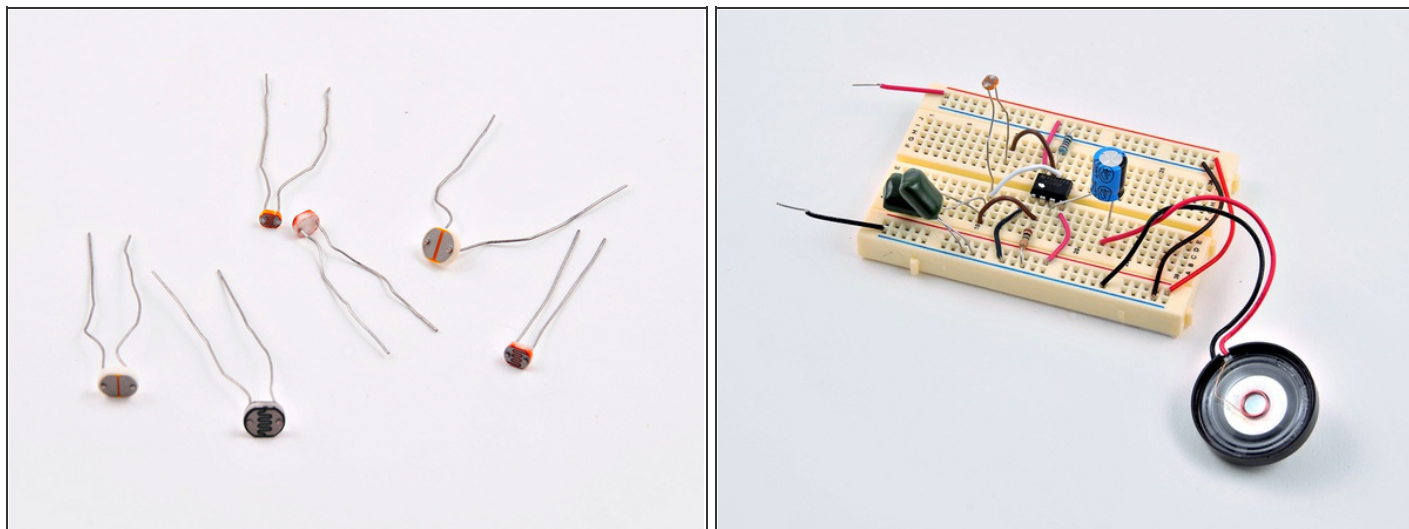

- Photodiodes work in this circuit, but you can get a broader range of tones by swapping in photoresistors, which RadioShack sells in a 5-pack.
- Try different types of photoresistor, and also try removing one of the 0.22 F capacitors — this will alter the range of pitches you can produce.
- See and hear the Light Theremin in action [here](#) and [here](#).

The venerable 555 timer integrated circuit used in this project is the most popular IC of all time. You can learn more about it [here](#) and read about a [chance encounter](#) with the designer of the chip, Hans Carmenzind, on MAKE.

This document was last generated on 2012-11-01 12:49:04 AM.