

# 10-NOTE TONE SEQUENCER

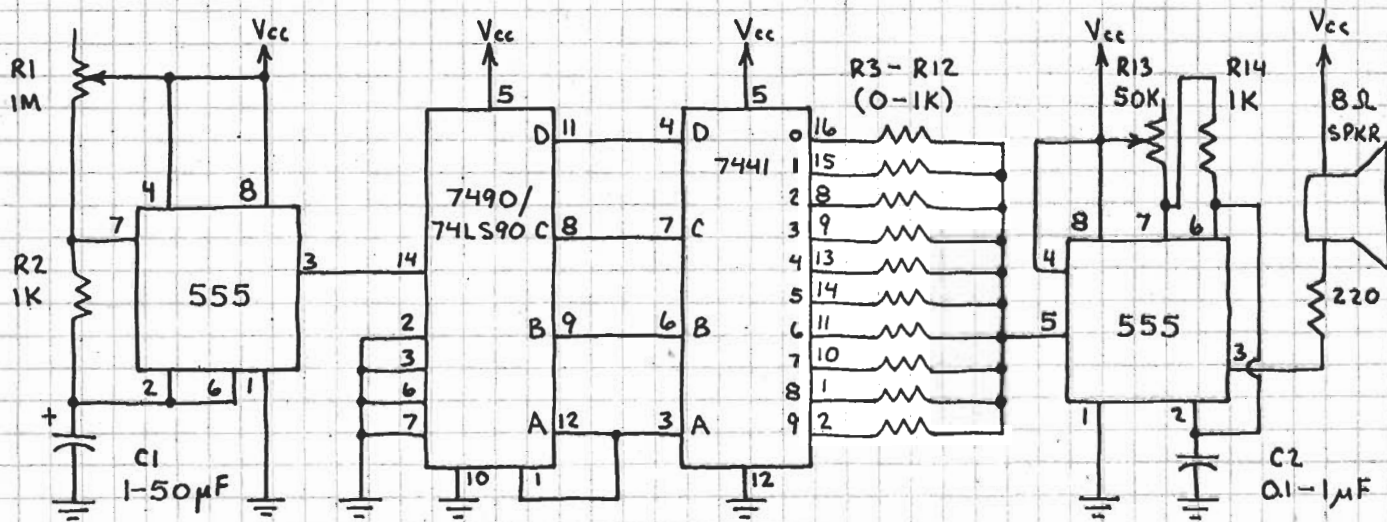

INCREASE C1 TO DECREASE TEMPO. INCREASE C2 TO INCREASE TONE FREQUENCIES. TONES ARE DETERMINED BY R3-R12.