

Basic power amplifiers

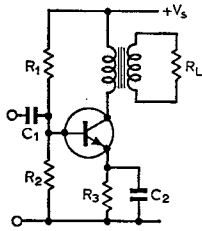

Typical data
 Supply: +15V
 Tr: BFY50
 R_1 : 1.2k Ω
 R_2 : 120 Ω
 R_3 : 10 Ω
 T: 3.25:1 turns ratio
 Quiescent current: 70mA
 Output power into 25 Ω load: ~400mW for 10% distortion

Class A

The classic transformer-coupled class A amplifier has been superseded for most purposes, but may still be applied where good isolation is required between source and load, or where the optimum impedance for maximum undistorted output is very different from the load impedance. Resistors R_1 and R_2 fix the base potential of Tr_1 provided the current through them is much greater than the base current. This base current is the required collector quiescent current divided by transistor h_{FE} . These parameters fix the value of $R_1 + R_2$ by the approximate relationship $R_1 + R_2 = h_{FE} V_s / m I_C$. The value of m the ratio of divider current to base current, is a compromise between stability and wasted power. Typically $m = 5$ to 20.

Emitter current (and hence I_C) is defined because the p.d. across R_3 equals the p.d. defined across R_2 minus the V_{be} of Tr_1 . For silicon transistors this is 0.6V and is stable to within 10 or 20% for most transistors under most operating conditions. The resulting p.d. across R_3 is again a compromise between high values for better stability and low values for minimum wasted power – not less than 0.5V and not greater than say 20% of supply voltage as a guide for power stages. Capacitor C_2 decouples R_3 to prevent negative feedback within the required frequency range. As R_3 may be a low resistance, C_2 must then have high capacitance.

Class C

The basic principle behind class C amplifiers is simple, the efficient realization difficult. The transistor conducts only on positive peaks of the input signal with the RC time constant determining the angle in the cycle for which conduction continues, the base-emitter of the transistor acting as a diode and allowing C to charge during the peak. The current in the output circuit is then in the form of pulses of current of which the fundamental term flows in the load if the LC circuit resonates at the fundamental frequency. A high-Q circuit ensures that the harmonics are sharply attenuated giving good output waveform simultaneously with high efficiency. A wide range of load and source impedances can be accommodated by introducing suitable LC networks at input and output (see card 6).

Subscriptions from: IPC Business Press Ltd, 33 Bowling Green Lane, London EC1R 0NE

Wireless World Circard Series 7:

Power amplifiers-2

Servo amplifier

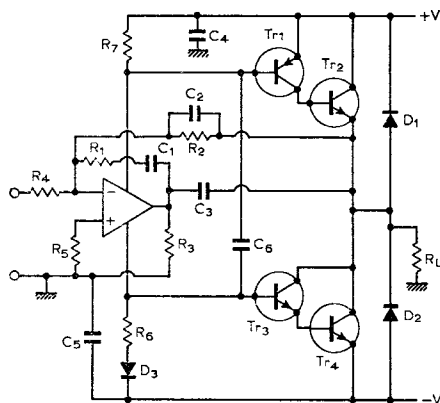

Typical performance
 Supplies: $\pm 15V$, 235mA
 Quiescent current: $\pm 1.8mA$
 A_1 : 741
 Tr_1 : BFR81
 Tr_2, Tr_4 : TIP3055
 Tr_3 : BFR41
 R_1, R_2 : 15k Ω
 R_3 : 47 Ω ; R_4, R_5 : 4.7k Ω
 R_6, R_7 : 180 Ω
 C_1 : 2nF; C_2 : 100pF
 C_3 : 4.7nF; C_4, C_5, C_6 : 470nF
 D_1, D_2 : SP2; D_3 : 1N914
 R_L : 18 Ω
 Risetime $\approx 30\mu s$ (4.8V pk-pk at 1kHz)
 V_{in} : 2.07V r.m.s. without clipping

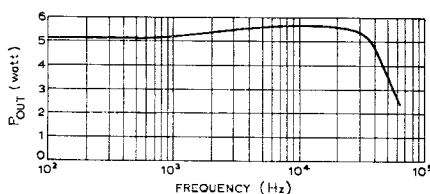

In servo systems a servoamplifier is needed when a high-power load must be driven from a low-power source. Amplifier A_1 acts as a see-saw amplifier having its gain determined by R_2/R_4 which can be adjusted to accommodate a wide range of input signal levels from a transducer. With no input signal, the output power transistors are virtually cut off, the only drain from the supply being the quiescent current of the operational amplifier (around 2mA). Hence the base-emitter junction of Tr_1 is forward-biased by only about 350mV due to the p.d. across R_7 . The base-emitter junctions of Tr_3 and Tr_4 would be forward-biased to a smaller extent unless R_6 was greater than R_7 . However, including D_3 and making $R_6 = R_7$ produces the desired bias with D_3 providing some temperature compensation for the base-emitter voltage of Tr_4 . The amplifier has a class B push-pull output stage so that a bipolar input signal produces class B currents in its supply leads. These currents are used to provide the base drive to the compound power transistors which supply the load currents to R_L in push-pull. Transistors Tr_3 and Tr_4 form a Darlington pair while Tr_1 and Tr_2 are its complementary equivalent. The Darlington configuration is used to provide high current gain to ensure that the load current is much larger than the amplifier's quiescent current. To guard against instability, R_1 and C_1 provide feedback around the operational amplifier and R_3 and C_3 provide feedback around the power stage. Bandwidth of the amplifier is controlled by C_2R_2 time constant which can be held fixed when the gain is varied by R_2 , if C_2 is also adjusted. Diodes D_1 and D_2 protect the output transistors against breakdown when the load is highly inductive.

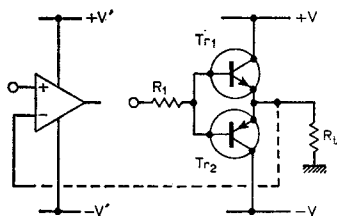

Supplies $V = \pm 6V$,
 $V' = \pm 15V$
 Tr_1 : BFR41
 Tr_2 : BFR81
 IC_1 : 741
 R_1 : 470 Ω
 R_L : 15 Ω
 Output power 0.92W at
 64% efficiency
 Output voltage swing:
 10.5V pk-pk for $\pm 6V$
 supply

Class B

The complementary pair of transistors acting as emitter followers comprise the basic class B push-pull stage. Transistor Tr_1 conducts during the positive half-cycle and Tr_2 during the negative half cycle. For input voltages close to zero neither transistor conducts as each requires a finite base-emitter voltage for conduction to commence ($\sim 0.5V$ for silicon devices). Non-linearities at low-levels make direct voltage drive at the bases unattractive, with the resulting cross-over distortion being very apparent in badly designed amplifiers of this time. If the output stage is included within the feedback loop of a high-gain amplifier the negative feedback reduces the distortion very considerably. At high frequencies the falling gain of the op-amp prevents the feedback from being fully effective and the crossover reappears. Voltage-gain as shown is unity, but standard feedback networks may be used to obtain any desired voltage gain. Output may be increased to 1.75W into 8 Ω but heat-sinking is then advisable. If the objectionable audio effects of cross-over are to be minimized biasing networks are inserted between the transistor bases.

Class D

In the class D amplifier, one or more transistors act as switches, connecting the drive point of an LR series circuit to the supply lines. This delivers a square wave to the LR circuit and provided the reactance of the inductor is high at the switching frequency there is little output. If the duty-cycle of the input waveform is altered the output will have a mean level which is a function of the duty cycle. A frequency lower than that of the basic switching frequency is used to modulate the pulse-width/position of the square wave generator and the low voltage is then a function of that signal voltage. For ideal transistors there is no power lost at the switching frequency and the overall efficiency can approach 100%. Diodes clamp the output voltage to the supply lines. The drive voltage must be large enough to saturate the transistors.

Further reading

Oxborne, M. R., Design of tuned transistor power amplifiers, *Electronic Engineering*, 1968, pp.436-43.
 Stewart, H. E., Engineering Electronics, Allyn & Bacon 1969, pp.589-642.
 Birt, D. R., Modulated Pulse Amplifiers, *Wireless World*, 1963, pp.76-83. (Also subsequent articles and letters.)

Cross references

Series 7, cards 4, 5, 9, 10, 11 (class A), 2, 3, 7, 8 (class B), 6 (class C), 12 (class D).

© 1973 IPC Business Press Ltd.

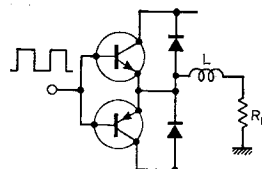

Component changes

Useful range of supplies: ± 6 to $\pm 18V$.
 Output power and efficiency fall as supply voltage is reduced: typically P_{out} is 0.8W and efficiency is 65% with $\pm 6V$ at 1kHz. With maximum drive, P_{out} falls as R_L increases: for supplies of $\pm 15V$, typically, P_{out} is 12.6W for $R_L = 6.8\Omega$ and $P_{out} = 3.8W$ for $R_L = 25\Omega$. Total harmonic distortion falls as drive increases: typically 0.45% for $V_{in} = 2.8V$ and 5.3% for $V_{in} = 150mV$ (supplies $\pm 15V$, $R_L: 18\Omega$ and $f = 1kHz$ sinewave).

Circuit modification

- The Tr_1 - Tr_2 and Tr_3 - Tr_4 Darlington pairs in the output stage may be made single n-p-n and p-n-p transistors. Ideally, these transistors should have high current gains to provide a peak load current that is significantly in excess of the quiescent current in the amplifier. They also need to have a higher power rating and the combination of high power, high current gain and wide bandwidth is not an easy specification to meet at low cost. The use of single BRF81 and BRF41 transistors provides a reasonable compromise.
- A modification which can improve stability while allowing some quiescent current in the output stage, i.e. biasing in class AB, is obtained by including resistors in the equivalent emitters of the drive transistors, increasing the p.d. across R_6 and R_7 and/or placing a diode in series with R_6 and R_7 . The resistors in the emitters can be selected to provide the required quiescent current. (See circuit left.)

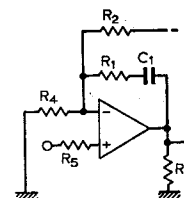
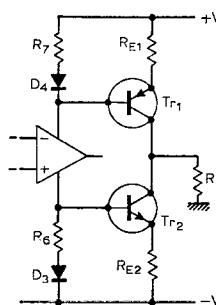

- In principle, any other feedback configuration may be used; for example taking the input signal to the non-inverting input of the operational amplifier and grounding the input end of R_4 converts the feedback to a series-applied form with the accompanying increase in input impedance. (See circuit right.) The operational amplifier may be supplied with differential input signals if desired.

Further reading

Campbell, D. L. & Westlake, R. T., Build a high-current servoamplifier with i.c.s, *Control Engineering*, December 1969, pp.91-4.
 Garza, P. P., Getting power and gain out of the 741-type op-amps, *Electronics*, 1 Feb., 1973, p.99.

Cross references

Series 7 cards 1 & 12.
 Series 2 card 4.
 Series 4 card 8.

© 1973 IPC Business Press Ltd.

Pulse buffer amplifier

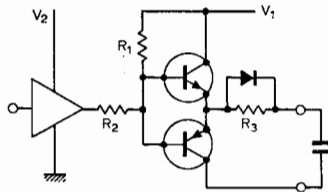

Typical performance
 V_1 : +14V; V_2 : +5V
 Tr_1 : TIS45; Tr_2 : TIS50
 IC_1 : 1/6 SN7406
 R_1 : 470 Ω ; R_2 : 100 Ω
 R_3 : 10 Ω
 D_1 : PS101; C_1 : 680pF
 Input pulse height: 4V
 Duration: 600ns
 P.R.F.: 50kHz
 Rise time: 20ns

Circuit description

The complementary symmetry output stage commonly used in class B amplifiers is equally applicable to pulse outputs. The problem here is that using only a single transistor in the output will only allow any capacitive load to have either a fast rise time or a fast fall time, but not both. Or if the output stage is operated in class A, it needs a quiescent current greatly in excess of the charging current required by the capacitor to achieve a high rate of rise and/or fall. The class B push-pull stage shown has Tr_1 driving the capacitor in the positive direction when a positive-going edge is applied at the base connection, while Tr_2 drives the capacitor in the negative direction. Rise and fall times are now determined by the current flow in the capacitor, which on the positive-going edge is limited by the base current that can be supplied by R_1

Output pulse: rise time 49 ns; fall time 32ns; pulse height: $\approx V_1$ (Rise and fall times measured between 10% and 90% levels). Variation of rise and fall time with several capacitive loads shown opposite. Some small distortion effects on input drive pulse were not apparent on the output pulse.

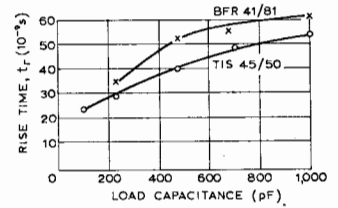
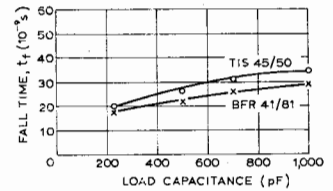

as D_1 is allowed to conduct. On the negative-going edge, current through R_2 is significantly greater and could cause excessive current flow in Tr_2 but the diode is reverse biased and R_3 takes the place of limiting action previously provided by R_1 . It is not possible in a simple circuit of this kind to choose a simple bias network for R_1 and R_2 which would give the same bias drive current in both directions.

IC_1 is a open-collector high-voltage output device which pulls the potential at the bases of Tr_1 and Tr_2 to a low value when in conduction, and when out of conduction allows the bias to rise towards V_1 via R_1 .

Wireless World Circard Series 7:

Power amplifiers-4

Push-pull class A power amplifier

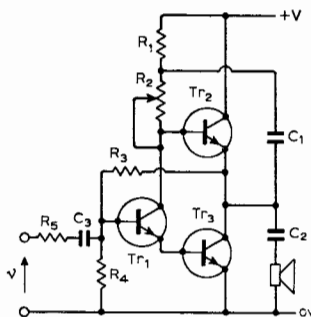

Tr_2, Tr_3 : TIP3055
 Tr_1 : BFR41
 C_2 : 2,000 μ F
 C_1 : 470 μ F
 C_3 : 100 μ F
 R_1, R_5 : 220 Ω
 R_2 : 250 Ω
 R_3 : 470 Ω
 R_4 : 120 Ω
 R : 3 Ω
 Supply: 12 to 14V

Circuit description

Class A push-pull amplifiers have at least two active devices in the output stage, and each device should operate under the same quiescent conditions. A drive circuit using one or more devices provides antiphase signals to the output pair which should have matched parameters. Thus a minimum of three transistors is called for and more are commonly required. By using current phase-splitting, a simple circuit results which still gives adequate efficiency and distortion figures. The key feature of the circuit is that the current in R_2 remains constant throughout the a.c. wave form while its d.c. value can be adjusted to set the desired quiescent current. Bootstrapping

Typical performance

For supply of 13V, quiescent current of 950mA, max. output for 3% distortion is 12V pk-pk into 5 Ω (3.6W). Mean current falls to 820mA at max. output. Full power bandwidth: 20Hz to 100kHz. Hum and

noise: 80dB below full output. Quiescent current: 1.25A @ 13V. Output power: 5W into 3 Ω @ 5% i.m.d. Distortion: <1.1%, 1W into 3 Ω , 100Hz to 10kHz. Voltage gain \sim -2. Input impedance \sim 250 Ω .

via C_1 ensures that any increase in the collector potential of Tr_1 is transferred via the emitter follower action of Tr_2 to reappear at the junction of R_1 and R_2 . Hence the charge in p.d. across R_2 approaches zero except at very low frequencies where the reactance of C_1 becomes significant. As there is no change in R_2 current, any increase in Tr_1 current increases the base current of Tr_3 while reducing the base current of Tr_2 by substantially the same amount. Accurate current phase-splitting together with matched current gains of Tr_2, Tr_3 keep the distortion low. Overall negative feedback via R_3 defines the output quiescent voltage as a multiple of the base voltage of Tr_1 (\sim 1.3V) and the ratio R_3/R_4 scales this base voltage up to half the supply voltage, i.e. the output transistors operate with equal V_{ce} as well as equal I_e .

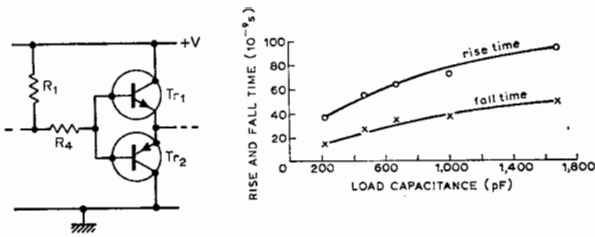

Component changes

● Transistors Tr_1 and Tr_2 can be replaced by BFR41 & BFR81 or BC125 & BC126 with poorer rise and fall times.

Typical comparison

| | rise time (ns) | fall time (ns) |
|-----------|----------------|----------------|
| TIS45/50 | 12 | 12 |
| BC125/126 | 28 | 14 |
| BFR41/81 | 38 | 15 |

● For each capacitor value, overshoot on leading and trailing edges of output pulse is approximately 25% of pulse level.

● Resistive load: 100Ω , V_1 : 14V, V_2 : +5V; output pulse excursion is from 1.6 to 12V.

Pulse width: $6\mu s$. Useful frequency range 3 to 100kHz. Corresponding mean current from supply 1.5 to 30mA d.c.

● IC₁: SN75451A or SN7407 for greater output voltage levels and faster rise times.

Circuit modification

● Rise and fall times for the circuit left are given centre. The lower level of drive pulse from the i.c. is approximately

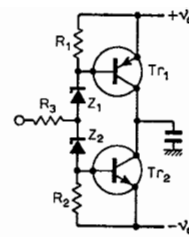

zero and hence pulse rise times will be slightly larger than in the original circuit.

● An alternative arrangement is shown right. If the drive voltage goes positive, the Zener diode transfers current to the base of Tr_2 which brings Tr_2 into conduction, clamping the output to the negative supply rail, with very small saturation effects. Conversely, if the output swings negative Tr_1 conducts and clamps the output to the positive rail, i.e. the peak-to-peak output swing into the load is almost equal to the supply rail values.

Further reading

Texas Instruments Technical Seminar 1972, m.o.s. memory drivers.

SGS-Fairchild, Industrial Circuit Handbook, 1967, p.38.

Williams, P., Voltage following, *Wireless World*, vol. 74, 1968, pp.296.

Cross references

Series 6, cards 1, 2 & 8.

© 1973 IPC Business Press Ltd.

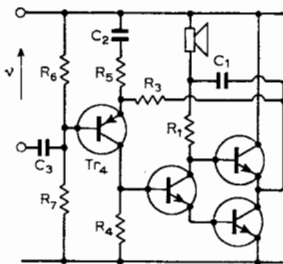

Component changes

Tr_2, Tr_3 : Power transistors with closely matched h_{FE} at operating current. Quiescent power (at least twice max. output) determines types and heat sinks.

2N3055 for $P_o > 5W$. MJE521 for $P_o > 1W$.

BFY50, BFR41, etc., for $P_o < 1W$.

Tr_1 : BFY50, BFR41, 2N3053 for most applications.

C_2 : Reactance $< R_L$ at lowest freq. Typically 200 to 5000 μF .

C_1 : Reactance $\ll R_1$ at lowest freq. Typically 100 to 500 μF .

R_1, R_2 : Set output current $V_s/2(R_1 + R_2) \approx 2I_s/h_{FE}$. One resistor made variable to adjust mean current. Typical range 100 Ω to 1k Ω (higher values for low-power circuits).

R_5 : Sets voltage gain $\sim -R_3/R_5$ and input resistance $\sim R_5$.

R_3, R_4 : Set output voltage (quiescent) to $\sim 2V_{be} [(R_3/R_4) + 1]$. Current in R_3, R_4 to 5 to 20 times base current of Tr_1 . Typical values R_4 : 100 to 500 Ω . R_3 : 300 Ω to 3k Ω .

Circuit modification

● Open-loop gain of the original circuit is low and feedback that can be used may not reduce distortion sufficiently. Simple bias circuit leaves the output at a fixed multiple of V_{be} rather than at the supply centre point, i.e. resistors require readjusting for different supply volts. Adding Tr_4 increases open-loop

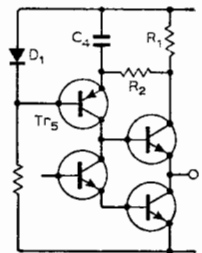
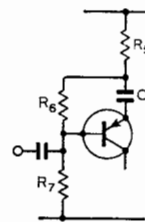

gain, allows 100% d.c. series-applied feedback and has input feedback and load all referred to same supply line. This eliminates bootstrap capacitor provided speaker can tolerate direct quiescent current of driver stage. For output at mid-point of $R_6 \approx R_7$. Voltage gain $\approx (R_3/R_5) + 1$. Reactance of $C_2 \ll R_5$ at lowest frequency of interest. Typically R_4, R_3 : 1 to 10k Ω , R_6, R_7 : 20 to 200k Ω . Other values as before.

● For higher input impedance, input potential divider may be bootstrapped. Interchanging locations of R_5, C_2 allows R_6 to be bootstrapped, almost doubling input impedance.

● Quiescent current depends on current gains of Tr_2, Tr_3 . By monitoring circuit mean current and using result to control drive current Tr_1 , mean current can be made constant, e.g. for Tr_5 a germanium transistor, D_1 a silicon diode, mean p.d. across R_1 is controlled at 0.4V.

Further reading

Linsley Hood, J. L., Simple class A amplifier, *Wireless World*, vol. 75, 1969, pp.148-53.

Markus, J. (ed.), Improving signal transfer in Electronics Circuits Manual, 1971, p.19.

Allison, W., Self-biasing class A power amplifier, *Wireless World*, vol. 78, 1972, p.577.

© 1973 IPC Business Press Ltd.

High-voltage amplifier

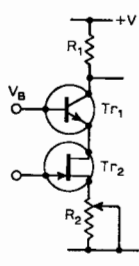

Typical performance

Supply: +100V
 Tr₁: MJE340
 Tr₂: 2N3810
 R₁: 10kΩ; R₂: 456Ω
 Quiescent voltage: 52V
 V_B: 10V
 Input signal: 7V pk-pk
 Output voltage: 84V pk-pk

Gain constant up to 20kHz
 Variation of output with R₂ not decoupled shown opposite.
 Effective output impedance of transistor configuration 5MΩ.

Circuit description

The characteristics required by an amplifier may include high voltage gain and in some applications the ability to withstand high output voltages simultaneously. Such a combination is not available within a single device, but the circuit shown arranges that the necessary input impedance gain characteristics are obtained by Tr₂ and the high voltage characteristics by Tr₁. The input characteristics aimed at were that the device should behave with a defined gain, so that the whole system could be considered equivalent to a valve. Transistor Tr₂ is thus a field-effect transistor whose gain is controlled by the quiescent current, which may be set by R₂. The drain of Tr₂ feeds into the emitter of Tr₁ whose base is maintained at a constant potential, just high enough to ensure that Tr₂ has a quiescent voltage that is above its pinch-off value. The bias voltage should be obtained from a low impedance circuit.

Hence Tr₂ is operating into a low impedance, while Tr₁ is virtually a common-base stage and has thus the highest voltage rating that it could possibly have. The current at the collector of Tr₁ is essentially the same as the emitter current as the current gain from emitter to collector is nearly unity. There is no significant Miller/Blumlein effect between the collector of Tr₁ and the gate of Tr₂ as the voltage swing at the collector is isolated from the gate of Tr₂. The capacitance between Tr₁ collector and base is now effectively a capacitance to ground rather than to the input of the amplifier. However this capacitance still affects the output characteristics, as it is in parallel with R₁ for a.c. and determines the bandwidth of the amplifier. The problem is more severe than in many low-voltage amplifiers because R₁ will have a much higher value for a given quiescent current because the p.d. across it may be in excess of 100V. This is the usual penalty to be paid for a high-voltage gain, i.e. the associated high load impedance will have a longer time constant for a given capacitance. The voltage rating is close to the V_{CE} breakdown of Tr₁.

Component changes

- Decouple R₂ with 150μF capacitance to retain g_m of the combined transistors. Output 82V pk-pk for an input signal of 2.4V pk-pk. Low frequency cut-off then 5Hz.
- Range of V_B 8 to 11V – value not critical, with no significant effect on performance.

Wireless World Circard Series 7:

Class C power amplifier

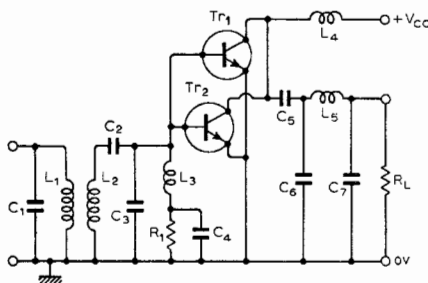

Typical data

Supply: 12V
 Tr₁, Tr₂: BFR41
 R₁: 100Ω; R₂: 50Ω (carbon)
 C₁: 180pF; C₂: 360pF
 C₃: 47pF; C₄: 10nF
 C₅: 500pF; C₆: 190pF
 C₇: 805pF; L₁: 2.7μH
 L₂: 2.16μH; L₃: 2.38mH
 L₄: 230μH; L₅: 1.51μH

Circuit description

Many class C amplifiers find application in the v.h.f. and u.h.f. bands, special transistor fabrication techniques being used to optimize their performance. For correct design it is necessary to establish a suitable model for the transistor behaviour under class C conditions, some manufacturers providing the appropriate data. In general, this data is not available for class C designs operating at frequencies lower than about 10MHz, so that a successful circuit normally results from a breadboard version using variable capacitors. The circuit shown above was produced on this basis where C₂, C₃, C₅, C₆, C₇ were originally fixed capacitors 'padded' out with variables. Source and load resistance were 50Ω and the output power obtained at 7.2MHz was 1.41W with a drive signal producing

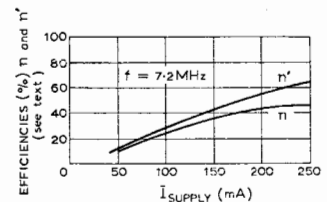

250mA supply current. Overall efficiency was only 47% (see graphs) but taking account of the d.c. drop (3.52V) across the r.f. choke L₄ efficiency rises to 66.5%. Hence L₄ should have low resistance, but its effect is less noticeable at lower currents. Transistors Tr₁ and Tr₂ were general-purpose transistors connected in parallel to reduce dissipation problems. The tuned networks in the input and output circuits should match the source to the transistors and the transistors to the load for maximum power transfer. Careful layout is essential and the circuit can easily oscillate as L₃, L₄ and the collector-base capacitance of the transistors form the basic arrangement of a Hartley-type oscillator.

Component changes

The circuit can operate over a limited frequency range and a wide range of supply voltages and power levels provided the input and output networks are re-adjusted to cater for the changing values of transistor input and output resistance and capacitance.

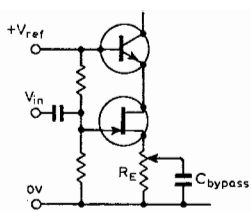

- Supply may be increased up to 300V with appropriate changes in R_1 and R_2 to control quiescent voltage. Typically (i) supply: +200V, V_Q : 110V, R_2 : 122 Ω , V_{in} : 7V pk-pk; V_{out} : 180V pk-pk; R_1 : 10k Ω . (ii) supply: +300V, V_Q : 150V, R_2 : 1.5k Ω , R_1 : 68k Ω , V_{out} : 275V pk-pk.
- Increase of +V from 100 to 200V, maintaining circuit resistors constant reduces h.f. cut-off by approximately 20% indicating that this is dependent more on external components rather than operating conditions.

Circuit modifications

- F.E.T. g_m is controllable by varying negative feedback. A wide range of control is possible with the circuit shown left. Because the gate is at positive, R_E can be large for chosen quiescent value of drain current, the feedback being varied via C without then altering the d.c. state of the circuit.

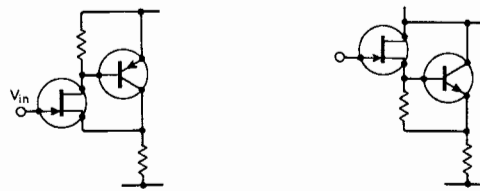

- F.E.T. g_m can be boosted by adding a p-n-p bipolar transistor to achieve a complementary pair (centre), or an n-p-n transistor for a Darlington pair (right), as the output impedance may be considered to be approximately $1/g_m$. The effective output impedance is less than that of the f.e.t alone.

Further reading

Designers casebook. *Electronics*, 1 Feb., 1973, p.99.
 Greiter, O., Transistor amplifier output stages, *Wireless World*, vol. 69 1963, pp.310-3.
 High voltages switched with a single transistor, 400 Ideas for Design, Vol. 2, 1971, Hayden.

© 1973 IPC Business Press Ltd.

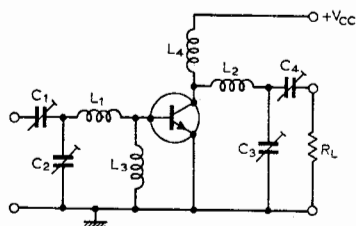

Alternative general-purpose transistors can be used, such as BFY50.

Single transistor can be used when reduced power is acceptable.

Input transformer can be dispensed with if alternative input and output networks used (see over).

Circuit modifications

Correct design procedures for class C r.f. power amplifiers tend to be highly analytical due to the need to consider the correct choice of input and output coupling networks, their working Q-factors, degree of harmonic rejection, possible causes of spurious oscillation and the d.c. operating conditions. For a successful design the impedances at the transistor input and output terminals must be known under the desired operating conditions. Use of small-signal parameters leads to considerable errors in a class C design as the voltage and current swings are so large in such a power amplifier. When class C transistor data is available it is normally provided in the form of equivalent parallel input resistance and reactance and parallel output capacitance as a function of frequency and power output. The equivalent parallel output resistance is

given approximately by $R = V_{cc}^2/2.P_{out}$. Even with this data available a choice must be made from the large number of possible input and output coupling networks. Often a T-configuration is suitable for both networks as shown left. These networks complex-conjugate match the source to the transistor and the transistor to the loads. Both networks introduce losses due to component imperfections. Choice of the working Q-factors is a compromise between losses in the coupling networks, their selectivity and realizable component values. If the loaded-Q is high the capacitors will be small, the selectivity will be high but the losses will be large. A low working Q-factor implies the opposite. When the available data is correctly interpreted it will normally still be necessary to tune the amplifier for optimum performance, for example by adjustment of C_1 to C_4 . Complete design procedures are given in the first three references.

Further reading

Motorola, application note AN-282: Systemizing r.f. power amplifier design, 1967.
 Hilbers, A. H., On the input and load impedance and gain of r.f. power transistors, *Electronics Applications*, vol. 27, 1967, pp.53-60.
 Mulder, J., On the design of transistor r.f. power amplifiers, *Electronic Applications*, vol. 27, No. 4, pp. 1967, 155-171.
 Markus, J. (ed.), 8-MHz, 3-W amplifier, in *Electronic Circuits Manual*, 1971, p.15.

Cross references

Circard series 7, card 1.

© 1973 IPC Business Press Ltd.

Bridge output amplifiers

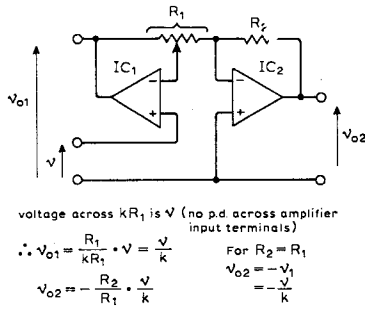

Typical data
 IC₁, IC₂: 741
 R₁: 10kΩ pot
 R₂: 10kΩ
 Supplies: ±15V
 R_L: 2kΩ
 Output voltage: 15V
 r.m.s. into 2kΩ (17.5V
 r.m.s. o/c) for $k = 0.1$ to
 1.0 at 1kHz.

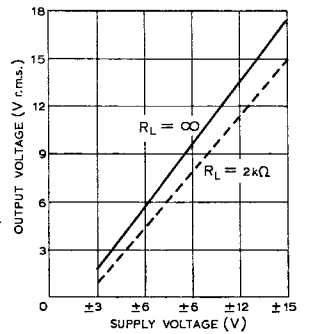
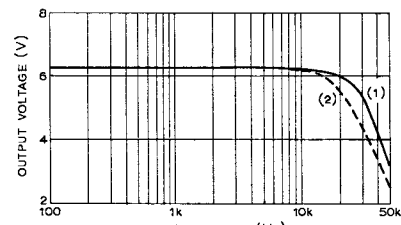

(1) Max output including increased drive at h.f.
 (2) Max output for distortion < 5%.

Circuit description

Most power amplifiers have a single-ended output, delivering to the load a voltage whose peak-to-peak value is at most equal to the total supply voltage. If transformers/inductors are allowed such single-ended stages may produce peak-to-peak output voltage swings of up to double the supply voltage, but only if the transistor breakdown voltages are equally high. The economic and performance limitations imposed by transformers point to the need for an alternative output configuration for increased output voltage swing. If the load is taken between the outputs of two amplifiers delivering inverted outputs of equal magnitude, then the load voltage being the difference between the two has twice the magnitude of each separately. The method is illustrated using standard operational amplifiers, but is applicable to amplifiers at all power

levels, where the constraint of a grounded load needs to be met. This particular configuration offers the advantage that a single potentiometer controls the gain of both channels. The exact balance is adjusted if required by setting $R_2 = R_1$. Equal magnitudes of output are ensured for this condition assuming ideal amplifiers because the two resistors carry equal current while their junction is a virtual earth point. A further advantage of this circuit is the high input impedance. As only one amplifier has a common-mode signal, the amplitude response differs somewhat, but the difference is only significant at those frequencies where the characteristic of each amplifier has departed significantly from the ideal. Slew-rate limiting, an output circuit phenomenon, determines the highest frequency at which large output voltages are obtainable with low distortion.

Wireless World Circard Series 7:

Class B quasi-complementary output

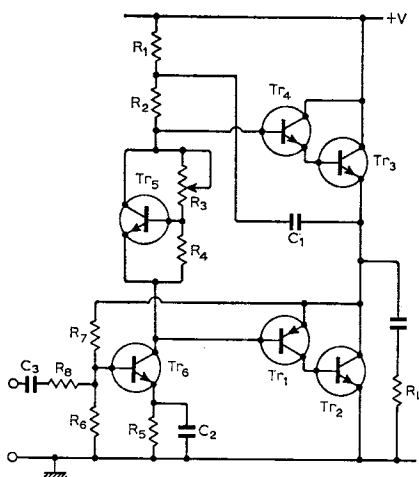

Typical performance
 Supply: +20V
 Tr₁: BFR81; Tr₂, Tr₃: TIP3055
 Tr₄, Tr₅, Tr₆: BFR41
 R₁, R₂: 1.5kΩ; R₃: 1kΩ
 R₄: 470Ω; R₅: 330Ω
 R₆: 1.8kΩ; R₇: 8.2kΩ
 R₈: 1kΩ; R₁: 8Ω
 C₁: 100μF; C₂: 22μF;
 C₃: 10μF
 Main d.c. output: 10V
 Input signal: 2.6V pk-pk

Output signal: 6.7V
 pk-pk
 Output power: 5.4 watts
 Harmonic distortion:
 5.8%
 Quiescent current:
 0.41A

Graphs of harmonic distortion and efficiency versus output power for loads of 15Ω and 8Ω shown opposite.

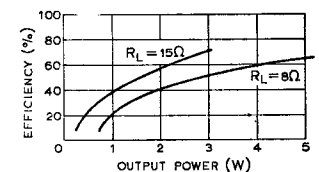
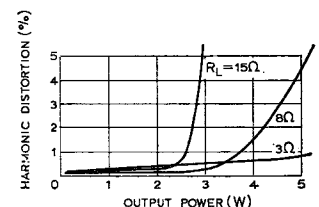

Circuit description

This is a circuit of a class B push-pull amplifier in which transistors Tr₃ and Tr₄ complement the pair Tr₂ and Tr₁. To use n-p-n transistors in the output stage for economy, the configurations of the two sections are different, i.e. Tr₃ and Tr₄ are connected as a Darlington pair and Tr₁ and Tr₂ as a complementary pair. They receive essentially the same a.c. drive, but with the bases separated by Tr₅. Tr₃ and Tr₄ conduct

for positive-going output signals and Tr₆ supplies base current drive to Tr₁ and Tr₂ for negative-going output signals. Transistor Tr₅ is used in the so-called amplified diode configuration in which the potential difference between the bases of Tr₁ and Tr₄ is set as a multiple of the V_{be} of Tr₅ by the potential divider R₃, R₄, i.e. R₃ can be adjusted to give the desired quiescent current in transistors Tr₂ and Tr₃. A forward bias is available which may allow the transistors to conduct to a small extent, just sufficient to minimize the crossover distortion that can never be entirely absent. Transistor Tr₆ is an inverting amplifier with overall negative feedback through R₇, the values of R₆ and R₇ determining the d.c. output potential

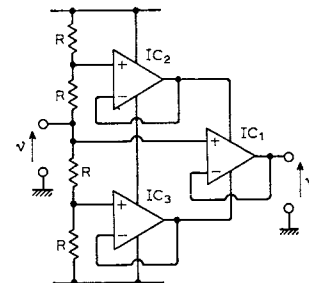
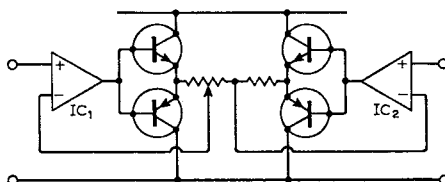
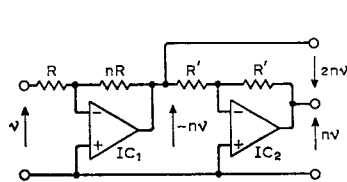

Circuit modifications

- Using two separate inverting amplifiers, with second set for a gain of -1 , control over both outputs is obtained by varying the gain of the first. As both are used as virtual-earth stages feed-forward compensation may be used to obtain stable performance with considerable increase in slew-rate and cut-off frequency.
- Current capability of the output stages can be increased by any of the ways suggested on the cards describing class B/class A amplifiers. The simplest addition is a pair of complementary emitter-follower combinations. Output current capability may be increased by one or two orders of magnitude, but the output voltage swing is slightly reduced because of the base-emitter p.d. of the transistors. Crossover distortion may be minimized by the addition of diode/transistor biasing networks to the transistor base circuits.
- An alternative to the bridge circuit for increased voltage swing is the principle of supply bootstrapping of which this is one version.
- Replace amplifiers by any compensated type (307, etc.); alternatively use uncompensated types (748, 301, etc.) with appropriate compensation capacitor (reduced compensation possible with increased gain leading to higher slew rate).

- Resistor values non-critical but $R_1 = R_2$ gives push-pull output (circuit usable as phase-splitter for succeeding stages). Resistor R_2 may be made adjustable to take up tolerances if outputs are required to be given ratio, leaving tapping point on potentiometer to vary total gain. Typical values for R_1, R_2 ; $1k\Omega$ to $250k\Omega$. Higher values lead to offset, drift and additional h.f. limitations; lower values absorb too much of the available output current.
- If unity gain is sufficient, IC_1 may be replaced by voltage follower, R_1 replaced by fixed resistor.

Further reading

- Greiter, O., Transistor amplifier output stages, part 1, bridge circuits, *Wireless World*, vol. 69, 1963, pp.17-20.
- Del Corso, D. & Giordana, M., Simple circuit to double the output-voltage swing of an operational amplifier with increased slew rate, *Electronics Letters*, vol. 8, pp.151/2.
- Ayer, J., Proportional d.c. motor control requires low-level inputs, *400 Ideas for Design*, Hayden 1971, p.225.
- Marshall, A. D., Differential input and output with op-amps, *Wireless World*, Jan. 1973, p.31.

© 1973 IPC Business Press Ltd.

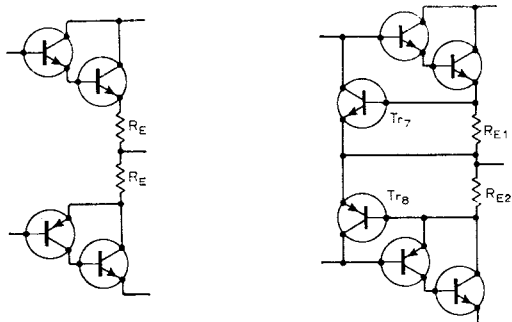

in conjunction with R_5 . Because R_5 is decoupled, the a.c. properties of the arrangement are determined by the ratio of R_7 to the source resistance. Resistors R_1 and R_2 are centre-tapped and this point is taken to the output via C_1 , which bootstraps R_2 so that the current through it remains constant throughout the cycle of output voltage swing.

Circuit modifications

- To avoid dangerous overcurrent in either of the output stage transistors, the current may be limited by adding series resistors R_e between the emitters and the output terminal (left).
- Middle circuit shows an alternative arrangement, adding transistors Tr_7 and Tr_8 . These are normally non-conducting except under overload conditions, i.e. as the output current increases the voltage drop across R_{e1} or R_{e2} causes Tr_7 or Tr_8 to turn on and divert the base current available to Tr_4 or Tr_1 , limiting the output current to V_{be}/R_e .
- Alternative configurations for the output stages are shown right (i) requires low and high power n-p-n and p-n-p transistors to make up the Darlington pairs, the minimum p.d.

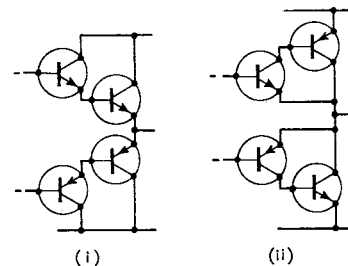

between input and output circuits being twice the V_{be} of a single transistor, (ii) uses complementary Darlington pairs with only one base-emitter path between input and output. Each pair comprises two inverting stages with 100% series-applied negative feedback giving unit gain.

Component changes

Adjustment of R_3 to avoid just visible crossover distortion gives a quiescent current of 7mA.

Further reading

- New uses for the LM100 regulator, National Semiconductor application note AN8-7.
- Grebene, B., Analog integrated circuit design, Van Nostrand 1972, pp.163-7.
- Amplifier efficiency (Letters), *Wireless World*, vol. 75, 1969, p.381.
- Hartz, R. S. & Kamp, F. S., Power output and dissipation in class B transistor amplifiers, RCA publication AN-3576. (Also in publication SSD-204A, p.594.)

Cross references

Series 7, cards 1, 2 & 3.

Broadband amplifier

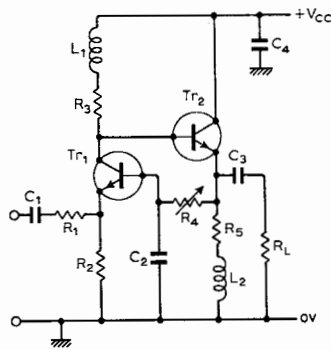

Typical performance
 Supply: +20V, 118mA
 Tr₁: BFR41; Tr₂: BFY50
 R₁: 33Ω; R₂: 150Ω
 R₃: 220Ω; R₄: 22kΩ
 R₅: 120Ω; R_L: 50Ω
 (carbon)
 L₁: 1.7μH; L₂: 220μH
 Power gain ≈ 14dB
 3dB bandwidth 64kHz to 16MHz

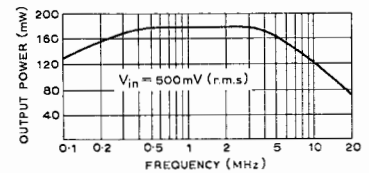

Circuit description

In many applications the transfer of power to a load at maximum efficiency is not the primary consideration. Often, power gain is required for small input signals over a wide frequency range without introducing significant intermodulation and harmonic distortion. The common-base stage offers the best linearity of voltage gain against collector current, the latter changing in sympathy with this input signal. The emitter follower, while not providing voltage gain, gives a current gain of the same order as a common-emitter stage and is therefore very useful for transferring power to a load. To obtain this transfer with little distortion, it is necessary to operate the emitter follower at a relatively high quiescent

current even for quite small input signals. The circuit uses a common-base stage feeding the load via an emitter follower. To maximise the gain-bandwidth product, Tr₁ and Tr₂ operate in regions where their current gain is much smaller than the normal values and they therefore have relatively high quiescent currents. The input resistance of the common base stage is inverse to its quiescent current, so that a high current allows the amplifiers input resistance to be matched to that of the source by a suitable choice of R₁. Resistor R₃ is determined from the required voltage gain (A_V) for equal source and load resistances $R_3 \approx A_V h_{fe2} R_L / (A_V + h_{fe2})$. Inductor L₁ is included to offset the capacitive loading due to Tr₂ and strays to maintain the gain at high frequencies. To deliver as much output current to R_L as possible at high frequencies choke L₂ is included in series with R₅.

Class A op-amp power booster

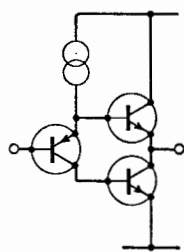
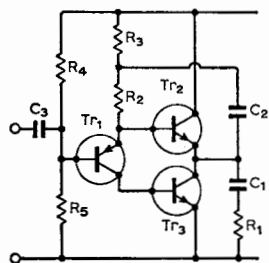

Typical performance
 Tr₁: BFR81
 Tr₂, Tr₃: TIP3055
 R₁: 3Ω; R₂: 250Ω pot.
 R₃: 220Ω; R₄, R₅: 10kΩ
 C₁: 2,000μF; C₂: 470μF
 C₃: 10μF
 Supply voltage: 12V
 Quiescent current:
 1.25A (set by R₁)

Output power for 1% t.h.d. into 3Ω load: 4.2W (supply current falls to 1.05A at full output). Output voltage swing to within about 0.7V of supply lines for 3Ω load and about 0.15V for 15Ω load.

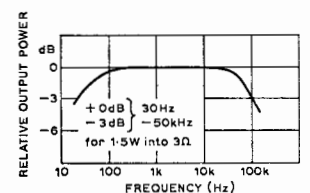
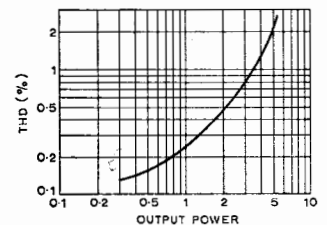

Circuit description

Available operational amplifiers have limited output currents, but may have a voltage swing approaching supply values. The circuit shown is class A buffer amplifier of unity voltage gain which may be added to such amplifiers to increase their output current to 1A or more. In addition the circuit is a very simple version of the voltage follower, having a low d.c. offset between input and output, a voltage gain very close to unity and a high input impedance. With the bootstrap technique applied the amplifier is capable of driving low load resistances to within < 1V of each supply line.

If a constant current flows in R₂, then as the base potential of Tr₁ increases the emitter current of Tr₁ decreases and with it the collector current.

This fall is fed to the base of Tr₃ causing it to conduct less, while the fall in emitter current releases more of the constant current in R₂ to flow in the base of Tr₃. Provided the current gain of Tr₁ is reasonably high, the magnitudes of the base current charges in Tr₂, Tr₃ are equal but the signs are opposite. This represents an approach to ideal current phase-splitting. The constant current in R₂ is provided by the bootstrap capacitor C₂, such that any change in the potential at the base of Tr₂ is coupled via the follower action to the positive end of R₂, i.e. with no resulting change of p.d. across R₂ in the ideal case. Resistors R₂ or R₃ require to be variable to set the

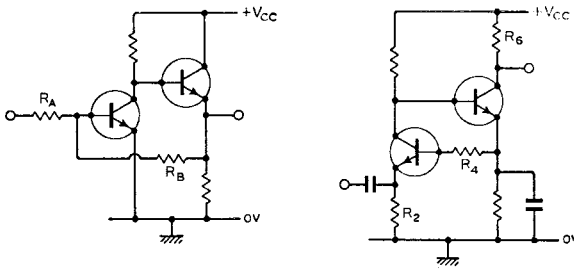

Component changes

With $V_{cc}(\text{min}) = +5\text{V}$, $V_{in}(\text{max}) \approx 140\text{mV r.m.s.}$, supply current is 30mA , and $P_{out} \approx 11\text{mW}$.

Tr_1 and Tr_2 can both be BFY50 or BFR41.

Tr_1 can carry a much smaller quiescent current, using for example an ME4103, with increased values of R_2 , R_3 and R_4 . R_1 can be increased or decreased to allow matching to source resistances greater or less than 50Ω respectively.

Circuit modifications

If the input signals are very small, output powers of around half a watt can still be obtained over a wide bandwidth by cascading a pair of amplifiers on the type described. When the gain-bandwidth product of the amplifier is not the most critical requirement and a higher efficiency is needed, the quiescent current in Tr_1 may be drastically reduced. Resistors R_2 and R_3 would then need to be increased, with a corresponding increase in R_4 , if this is to be the means of controlling the quiescent operating conditions. The lower Tr_1 current may be chosen to make the natural input resistance of the stage, in the absence of R_1 , the value required to match the source.

- Input resistance may be defined using shunt-applied feedback, as shown left, where the emitter of Tr_1 is d.c. or a.c. grounded, the feedback is not decoupled and the voltage gain is determined by the ratio R_A/R_B . The input resistance is largely that of R_A except at high frequencies where the feedback falls and the impedance at Tr_1 base must be considered.
- Inclusion of R_6 , as shown right, may be applied to both the previous circuits to allow an output to be taken from the collector of Tr_2 . To maximize the signal swing in the collector circuit of Tr_2 the bias network must be readjusted to leave a small voltage at Tr_2 emitter, say by reducing R_4 and R_2 in the original circuit. The output resistance is approximately R_6 ; this stage is therefore convenient for feeding directly into any other low impedance stage, such as that left, with R_A removed. This mismatch can often be of advantage in extending the bandwidth of the amplifier.

Further reading

Hirst, R., Wideband linear amplifier, *Wireless World*, vol. 75, 1969, pp.168-70.

Meindl, J. D. & Hudson, P. H., Low-power linear circuits, *IEEE Journal of Solid-State Circuits*, vol. 1, 1966, pp.100-11.

Lo, A. W. (and others), Transistor for Electronics, Chapter 9, Prentice-Hall, 1955.

Griffiths, H. N., Simple wideband amplifier, *Wireless World*, vol. 75, 1969, p.478.

Cross references

Series 7, cards 1, 4, 5 & 10.

© 1973 IPC Business Press Ltd.

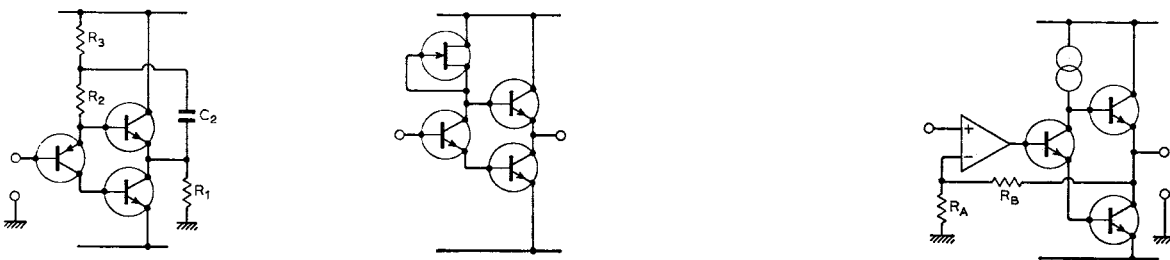

output current and stability of that current then depends on h_{FE} variation in Tr_2 , Tr_3 . The base-emitter p.d.s of Tr_1 , Tr_2 substantially cancel, as they can readily be chosen for junction area ratios matching the quiescent current ratios. As a class A amplifier, maximum theoretical efficiency is 50%. At full output the load power may approach 40% of supply power in practice, but the quiescent power is somewhat higher than the supply power at full load.

Circuit modifications

- The good d.c. offset characteristics allow the amplifier to be used as a voltage follower with d.c. coupling to the load. Bootstrapping should be retained unless the amplitude response is required to extend to d.c., as it swings the junction of R_2 , R_3 above the supply on positive signal swings. Hence it can drive Tr_2 base far enough positive to saturate Tr_2 hard making maximum use of available supply voltage. If the load is to be a.c. coupled but may carry a small quiescent current, the load resistance R_1 may replace R_3 .

- Any other constant-current circuit may replace the bootstrap arrangement, e.g. a f.e.t. either with gate strapped to

source as shown or with a resistor in the source lead to define some lower value of current.

- Although the distortion of the buffer stage above is low, the addition of a high voltage gain amplifier such as an op-amp can increase the voltage gain to $(R_B/R_A) + 1$ while providing sufficient overall feedback to make distortion very low. The wide bandwidth of the buffer stage together with its unity gain minimizes the risk of instability at high frequencies. Should this be troublesome an op-amp with external compensation may be used with increased compensation capacitor.

Further reading

Belcher, D. K., Inexpensive circuit boosts op-amp output current, 400 Ideas for Design, vol. 2, Hayden, pp.1-2.

Bloodworth, G. G., D.C. amplifier with unity voltage gain, *Electronic Engineering*, 1965, pp.112-4.

Electronic Circuit Design Handbook, Current boosters for i.c. op-amps, Tab, 1971, p.161.

Cross references

Series 7, cards 2, 4 & 8.

© 1973 IPC Business Press Ltd.

D.C. power amplifier

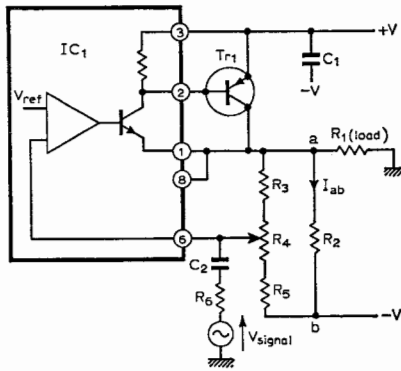

Typical performance
 IC₁: LM305 or LM100
 Tr₁: MJE271
 Supplies: ±15V
 R₁, R₂: 150Ω; R₃: 15kΩ
 R₄: 1kΩ; R₅: 1.8kΩ
 R₆: 10kΩ
 C₁: 1μF (tantalum);
 C₂: 10μF

Input signal: 2.8V r.m.s. at 100Hz
 Maximum output voltage before symmetrical clipping 6.2V r.m.s.
 Output power: 250mW
 Harmonic distortion: 0.35% at 1kHz, and 0.32% at 20kHz.

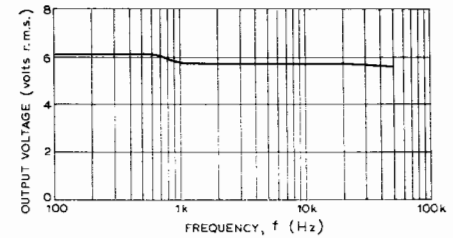

Circuit description

This circuit uses a voltage regulator, i.e. package to supply an output stage Tr₁ where the amplifier is to be used primarily with a unipolar signal, though it can also be interpreted as a class A output stage which can be a.c. coupled to a load. The i.c. regulator contains its own reference voltage and a separate feedback point (terminal 6) which allows the potential at the collector of Tr₁ to be set to some stable value which is a multiple of the internal reference voltage, that multiple being set by R₃, R₄ and R₅ the quiescent current in Tr₁ is then set by the bias resistor R₂ in conjunction with this predetermined voltage.

An a.c. signal can be superimposed at pin 6 via C₂ and R₆ the circuit then behaving as a see-saw amplifier, as the reference voltage leaves the feedback terminal 6 as an a.c. virtual earth. For d.c. purposes, the circuit may be treated as series applied feedback. The peak current in the load is limited to a fraction of the quiescent current for negative excursions; as the voltage goes negative the p.d. across R₂ falls and with it the current through R₂. The current in R₁ for this voltage exclusion can never exceed R₂ even when the transistor current falls to zero in the positive direction; however, much greater currents can be provided through Tr₁. The amplifier is thus an inefficient class A amplifier whose effectiveness can be improved by replacing R₂ by a constant-current stage which can sustain a given peak current in R₁ almost equal to the quiescent value, even for large voltage excursions in the negative direction. Capacitor C₁ is used to suppress h.f. oscillation and a low inductance type must be used.

Wireless World Circard Series 7:

Class D switching amplifier

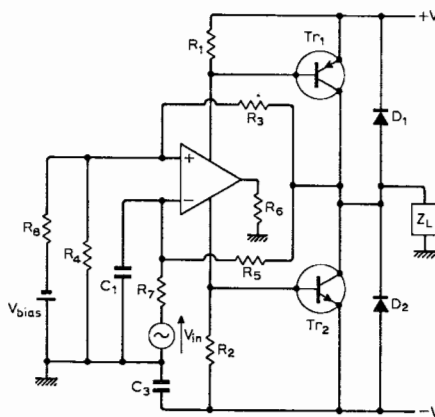

Typical performance
 A₁: 301
 Tr₁: 301
 Tr₂: BFR41
 D₁, D₂: SP2
 Supply: ±10V (4 to 15V)
 R₁, R₂: 180Ω, R₃: 10kΩ
 R₄: 100Ω, R₅: 4.7kΩ
 R₆: 470Ω; R₇, R₈: 1kΩ
 C₁, C₂, C₃: 100nF
 Z_L: 1mH (r = 0.9Ω)
 +15Ω

V_{bias}: -640mV to set mean load voltage to zero with V_{in} = 0.
 Switching frequency: 27.8kHz, max 40 kHz.
 With V_{in} = 0, supply current is ±20mA; with V_{in} = 3.4V pk-pk 100Hz; current is ≈ 130mA; power in 15-Ω

load ≈ 1.66W; residual "carrier" ≈ 300mV across 15Ω; overall efficiency 64%; output stage efficiency ≈ 76%; 3-dB bandwidth ≈ 600Hz. With rectangular input at 100Hz, output rise and fall times ≈ 600μs.

Circuit description

Basically, the circuit is an astable oscillator, generating a squarewave that is used to drive a complementary pair of output transistors into conduction on alternate half-cycles of the squarewave. The output transistors thus switch the voltage to the load at a frequency that is much higher than that of the signals to be amplified. The squarewave generator is designed around the operational amplifier A₁ which uses positive feedback via R₃ and R₄. The periodic time of the squarewave fed to R₆ depends on the time constant R₅C₁ if R₇ is much greater than R₅. To obtain a realistic switching frequency with

reasonable components and also to obviate the need for large input signals a compromise must be made in the value of R₇. Current in R₈ flows alternately in R₁ and R₂ producing p.d.s across these resistors that are sufficient to switch on Tr₁ and Tr₂ respectively. The signal applied to R₇ causes the mark-to-space ratio of the output waveform from the astable to vary in sympathy with the instantaneous value of V_{in}, so that the mean value of the voltage applied to the load also varies directly with the input signal. If the load impedance has an external filter, or is by its nature self-filtering such as with a motor, then the power drawn from the amplifier at the switching frequency is low and the useful signal power in the load will be high.

If the mark-to-space ratio of the squarewave generated by the astable is not unity with V_{in} = 0, it can be made so by a suitable choice of the bias supply and R₈. Diodes D₁ and D₂ protect Tr₁ and Tr₂ against breakdown when the load impedance is highly inductive.

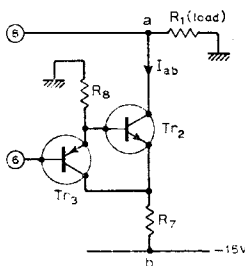

| current through Tr_1 (mA) | I_{ab} (mA) | load current (mA) | circuit element in a-b |
|-----------------------------|---------------|-------------------|-------------------------|
| 100 | 100 | 0 | R_2 |
| 200 | 150 | +50 | |
| 0 | 50 | -50 | |
| 100 | 100 | 0 | constant current source |
| 200 | 100 | +100 | |
| 0 | 100 | -100 | |

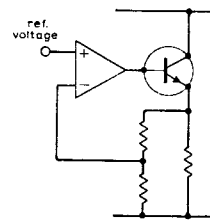

Onset of slew-rate limitation occurs at 70kHz for an output signal level of 16V pk-pk when the signal level is reduced to 3 to 5V pk-pk by reducing the input signal. Voltage gain is flat up to 100kHz, with 3dB fall-off occurring about 250kHz.

Circuit modifications

- Resistor R_2 is replaced by the Baxandall constant-current circuit shown left. Tr_1 : BFR81, Tr_2 : TIP3055, R_7 : 18 Ω , R_8 : 3.9k Ω . This permits a much greater input signal level before peak clipping occurs. Resistor R_7 is chosen for approximately a 100mA constant quiescent current in the path a-b (about 1.8V is available at terminal 6). If the transistor Tr_1 output current is 200mA pk-pk, then the output current swing in load R_1 is twice that for the case when R_2 is 150 Ω with the same quiescent current. A comparison of instantaneous currents for the two possible circuits between a and b is tabled above.

- The regulator may be replaced by the operational amplifier emitter-follower circuit, shown right. To maintain the d.c. stability of the output, the non-inverting terminal must be connected to a suitable stable reference voltage. If the d.c. power supply is stabilized, then this may be a tapping on a potential divider connected across the supply. For minimum drift, the effective resistance seen at both input terminals of the op-amp should be comparable.

Further reading

New uses for the LM100 regulator, National Semiconductor application note AN-8, 1968.

Amplifier efficiency (Letter), *Wireless World*, vol. 75, 1969, p.535.

Cross references

Series 3, card 8.

Series 7, card 12.

© 1973 IPC Business Press Ltd.

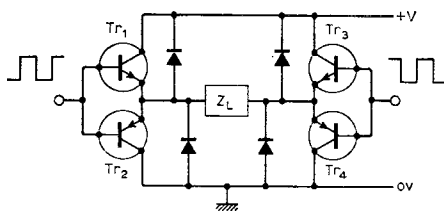

Circuit modifications

- The bias source to set the mark-to-space ratio of the squarewave to zero can be obtained by a potentiometer connected between ground and the appropriate supply line.

- While an inductor is normally used in series with a resistive load to filter out the h.f. squarewave, any suitable low-pass filter can in principle be connected between the junction of Tr_1 and Tr_2 collectors and R_1 . Another possible method is to connect a capacitor in parallel with the inductive smoothing choke so that it is resonant at the switching frequency. For example, with a choke of 1mH and $r = 1\Omega$, a parallel capacitance of 16nF would be resonant at switching frequency of 40kHz. At signal frequencies less than about 500Hz, the impedance of this tuned network is inductive, having a maximum impedance of about 3 Ω .

- The complementary pair of transistors forming the output stage can be replaced by a bridge-type network as shown left. The four transistors are fed with complementary pulse-width-modulated squarewaves which cause the transistors to be switched on and off in pairs. With Tr_1 and Tr_4 on current flows in the load in one direction and is reversed when Tr_2 and Tr_3 are switched on.

- Another practical form of bridge output stage is shown right using a pair of voltage comparators to generate the

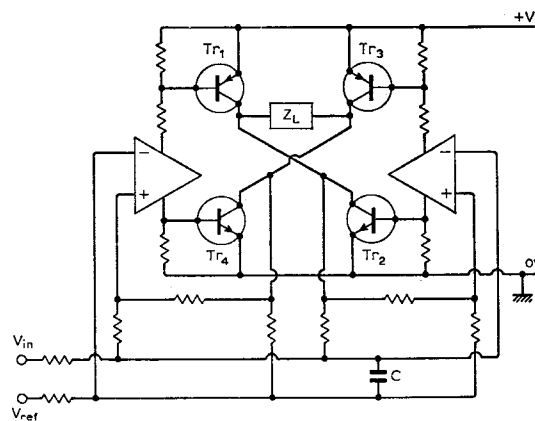

complementary pulse-width-modulated switching waveforms. The bridge of power transistors is connected across a single-ended supply. Component details are given in the first reference.

Further reading

National Semiconductor, data sheet and application notes on the LM311 voltage comparator, 1970.

Camenzind, H. R., Modulated pulse audio and servo power amplifiers, International Solid-State Circuits Conference, University of Pennsylvania, Philadelphia, 1966, pp.90/1.

Meidl, J. D., Micropower circuits, Wiley, 1969, pp.61, 64 & 65.

Garza, P. P., Getting power and gain out of the 741 type op-amp, *Electronics*, 1 Feb., 1973, p.99.

Cross references

Series 7, cards 1 & 2. Series 2, card 4. Series 3, card 1.

Series 4, card 8.

© 1973 IPC Business Press Ltd.