

Build PANAMIX

*A low-cost, 5-input
stereo/mono audio mixer
with full panning*

BY JAMES BARBARELLO

PANAMIX is a stereo/mono mixer that can handle up to five inputs at once, and has full panning capability. Unlike many other mixers, it will allow you to position each program source at full left, full right, or anywhere in between.

All controls, including input and master level controls, are slide potentiometers, giving the project the look and "feel" of a studio-type mixing panel. Panamix also uses readily available components, such as 741-type op amps. Current drain is so low that 9-volt transistor batteries are a practical and economical power source. Total parts cost is only about \$30.

About the Circuit. Referring to the schematic diagram (Fig. 1), three distinct sections can be identified. The first is the input level control section

POPULAR ELECTRONICS

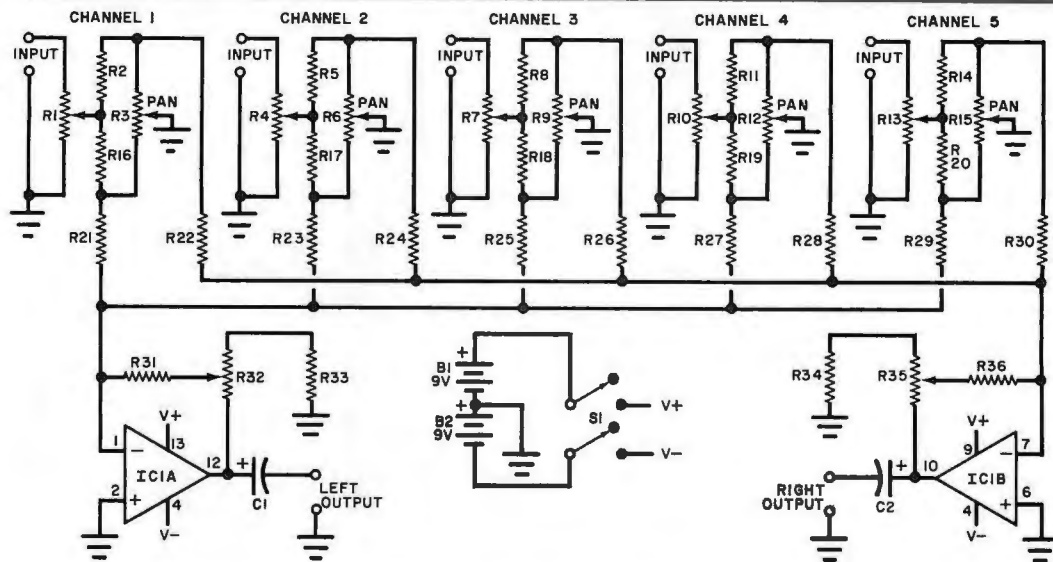

Fig. 1. Schematic diagram shows how five input channels are mixed down to a stereo output by an op amp summer.

PARTS LIST

B1, B2—9-volt transistor battery
 C1, C2—1- μ F, 16-volt electrolytic capacitor
 IC1—747 dual operational amplifier
 R1, R3, R4, R6, R7, R9, R10, R12, R13,

R15, R32, R35—10,000-ohm slide potentiometer (Radio Shack 271-223)
 R2, R5, R8, R11, R14, R16 through 31, R36—10,000-ohm, 5%, 1/4-watt resistor
 R33, R34—1000-ohm, 5%, 1/4-watt resistor
 S1—DPDT toggle switch

Misc.—Battery clips; 10" \times 7" printed circuit board; 7 miniature phone, RCA phone, or 1/4-inch phono jacks; hookup wire; solder; wood and sheet metal screws; etc.

(R1 for Channel 1), a 10,000-ohm potentiometer. It presents a constant resistive input impedance of 10,000 ohms and provides a variable amplitude signal to the second section, the panning circuit. For the input Channel 1, it consists of R2, R16, and potentiometer R3. As the wiper of R3 is moved upward, less and less signal appears at the right output, while more and more appears at the left output. If the wiper is then moved downward, the apparent position of the signal source moves from left to right. Although the position of the panning control does affect the total output of the panning section, the variation is not audibly noticeable.

The left and right outputs of the panning section are then processed by the third section, which performs output summing and level control functions. For the left channel output, it is composed of R21, R23, R25, R27, R29, R31, R32, R33, C1 and IC1A. These components form an op amp summer whose gain, allowing for losses in the panning section, is about 15 dB over the input signal level. The output impedance of each section of IC1, a 747 dual op amp, is about 75 ohms. Thus it will drive almost any

preamp or power amp with a medium to high input impedance. Each output is capacitively coupled to dc-isolate the output stage of the op amp from the output jacks.

Construction. "Panamix" is best assembled using a 10" \times 7" (25.4 \times 17.8 cm) printed circuit board. Figure 2 shows the etching and drilling and parts placement guides. Start by inserting all fixed resistors and soldering them into place. Then insert and solder IC1, using an IC socket or Molex Soldercons, if desired.

The slide pots have three terminals (one at one end and two at the other) and two tabs near the center. Insert each potentiometer carefully, so that the two tabs are touching the circuit board and the body of the potentiometer is perpendicular to the pc board. When you have correctly positioned each potentiometer, solder it in place. Then install C1, C2, R33 and R34 on the foil side of the board. This is done so that the board can be mounted in a custom enclosure. Attach leads for the input and output jacks and for S1, also using the foil side of the board. These leads are connected to the foil side to prevent any interference with the mo-

tion of the slide pots. All input and output leads should be shielded. The choice of connectors is optional. The author used miniature phone jacks for input and output connections, but RCA phono or standard 1/4-inch phone jacks can also be used.

Because the circuit draws only \pm 4mA, two nine-volt transistor batteries are used for a power source. You can power the Panamix from a line-operated supply, of course.

With all parts and connectors in place, Panamix is electrically complete. However, you will probably want to build an enclosure for the mixer. So a custom cabinet plan is included.

Layout of the front panel, which is formed from an 11" \times 8 1/2" \times 1/8" (27.9 \times 21.6 \times 0.32 cm) piece of Masonite is shown in the photo. Twelve 2 1/4" \times 1/8" (57 \times 3.2 mm) cutouts should be made to accommodate the control slides. A 1/4-inch (6.4-mm) hole is for power switch S1. Assembly details for the case are shown in Fig. 3. Hardwood is suggested for all sections except the circuit-board supports, which should be pine. White glue and 1/4-inch (6.4-mm) dowels can be used for mechanical rigidity and a pleasing appearance.

When the case and front panel have

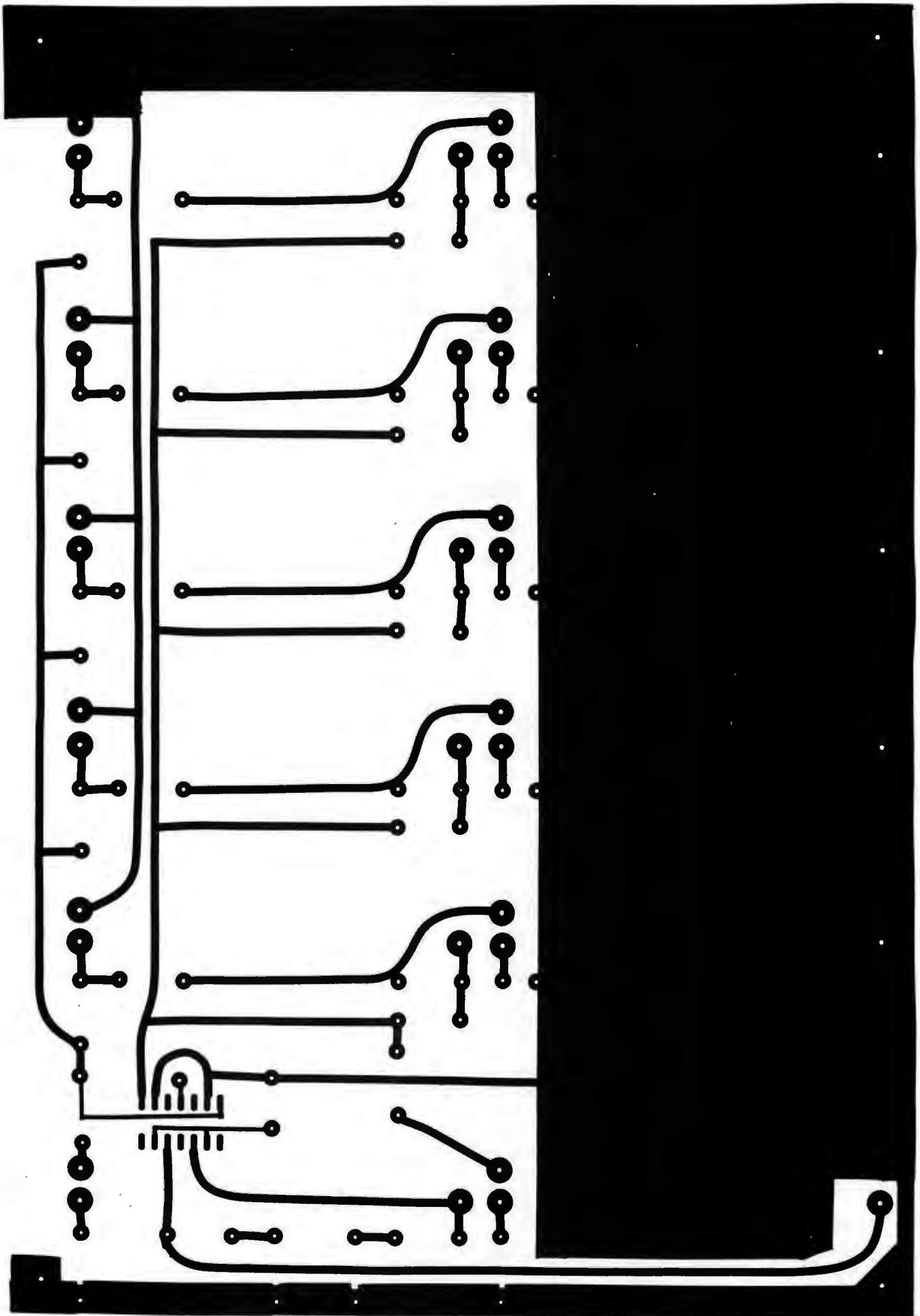

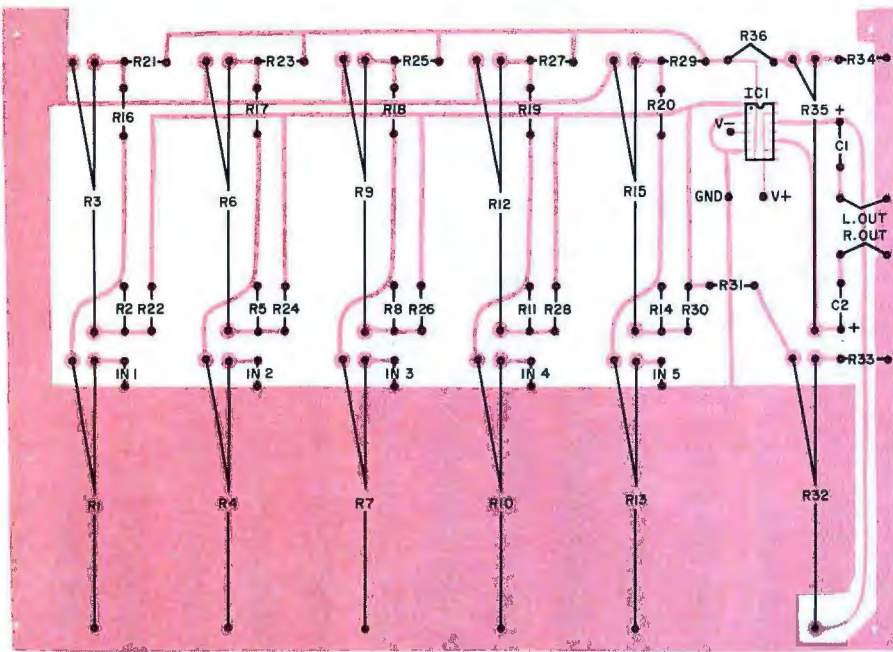

Fig. 2. The actual size etching and drilling guide for the printed circuit board is shown on the opposite page. Layout of components on the board is above.

been assembled, mount the panel and secure it to the support, with wood screws. Then turn the case upside down, and insert S1 into its mounting hole. Position the printed circuit board so that the slide controls move freely in their front panel slots. It might be necessary to bend the controls' solder lugs slightly to obtain smooth

motion, but be careful not to damage the pots, the board, or its foil. When the board has been properly aligned, it should be secured to the pine supports with self-tapping sheet metal screws. Press knobs down on each slide control.

A rear panel should be fabricated from a 12" x 1 1/2" (30.5 x 3.8 cm) piece of 16-gauge aluminum stock. Bend

the piece of aluminum at right angles 1/2" (1.27 cm) from each end to form a stubby "U" shape. Then attach the panel to the case, sinking sheet metal or wood screws through both arms of the "U". Drill mounting holes for the connectors you wish to use along the rear panel, and secure the jacks to the panel. Situate the batteries in any convenient location that will allow easy replacement. A retaining bracket for the batteries can be fashioned from a scrap of aluminum stock and should be secured to the case with a sheet metal or wood screw.

Using the Mixer. You can perform many different mixing functions with Panamix, such as converting a four channel "master" of a musical performance into a stereo format, mixing a multiple microphone conference setup into one or two tracks for recording or PA purposes, etc. You need only remember that panning position integrity with respect to the front panel markings is maintained *only* when both master level controls are set for equal volume. A significant difference between the levels of the output channels will shift the apparent "center" to one side. Experiment with all controls to get used to their "feel." For mono use, place all PAN controls to one side and use the appropriate output channel. ♦

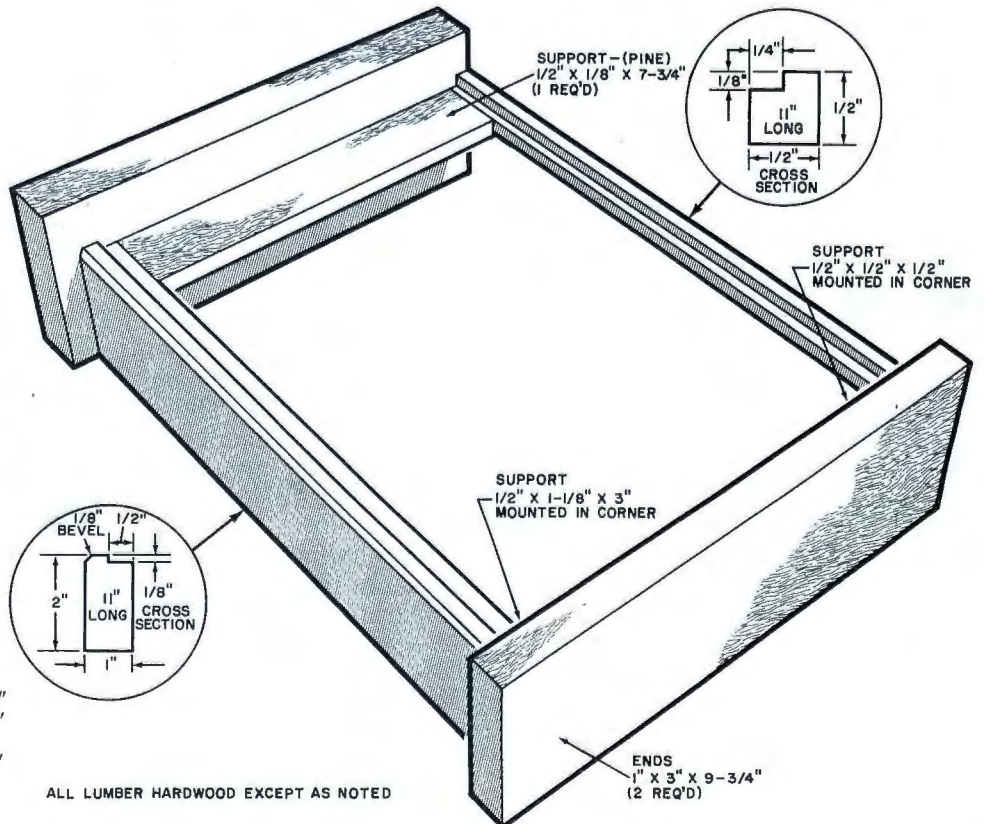

Fig. 3. A custom case for the Panamix can be made using this guide.

Bill of Materials

- 1—piece of Masonite 11" x 8 1/2" x 1/8"
- 2—pieces of hardwood 9 3/4" x 3" x 1"
- 1—piece of hardwood 11" x 2" x 1"
- 1—piece of hardwood 11" x 1/2" x 1/2"
- 1—pine support 7 3/4" x 1 1/8" x 1/2"
- 1—pine support 3" x 1 1/8" x 1/2"
- 1—pine support 1/2" x 1/2" x 1/2"

ALL LUMBER HARDWOOD EXCEPT AS NOTED