

Testing your notebook design for audio fidelity

THE WINDOWS LOGO PROGRAM FOR THE VISTA OPERATING SYSTEM HAS INTRODUCED NEW AUDIO-FIDELITY REQUIREMENTS FOR NOTEBOOK PCs. CRITICAL TROUBLESHOOTING TECHNIQUES CAN HELP YOU ACHIEVE COMPLIANCE.

As of June 1, 2007, the WLP (Windows Logo Program) began to impose detailed requirements on the audio performance of PCs and notebook computers using the Windows Vista operating system. The parameters in question, which the entire internal audio-signal path affects, include THD+N (total harmonic distortion plus noise), dynamic range, and crosstalk, among others. **Table 1** outlines Revision 3.09 of these playback requirements for the premium mobile class of computers.

The most noteworthy aspect of these requirements is that the industry is enforcing them. Microsoft's (www.microsoft.com) DTM (device-test manager) currently enforces a subset of the Microsoft Vista audio-fidelity requirements. The DTM Studio host computer provides an interface to the DTM-test program and test results (**Figure 1**). The system under test connects to a 2700 Series dual-domain audio analyzer from Audio Precision (www.audioprecision.com), which in turn connects to the Audio Precision host. The DTM controller controls all components via a network.

The audio analyzer can measure electrical performance only at the output jacks available on the system under test. Therefore, no one can enforce the speaker performance because the speaker is enclosed within the notebook PC box. Microsoft may soon change the DTM-test setup to accommodate acoustic-test capability, but, in the meantime, the WLP measures

electrical performance only for readily accessible outputs, such as the headphone- and line-output sockets.

Tests at the headphone-output jack validate the entire audio-signal path. System designers must therefore take care in selecting all active and passive components in that path. The audio-signal path in notebook computers and PCs begins at the south bridge, which is a motherboard chip that supports lower-speed PC functions, such as audio. The north-bridge chip supports memory and graphics. The south bridge provides an interface with the HDA (high-definition-audio) codec, which in turn feeds an analog signal to the audio amplifier in playback mode. The output of the HDA codec requires input coupling capacitors, because it can have a dc-bias voltage different from that of the audio-amplifier inputs.

Between the audio-amplifier outputs and the output jack, you may find a small EMC (electromagnetic-compatibility) filter, consisting of an inexpensive ferrite bead and a low-value ceramic capacitor (**Figure 2**). You can eliminate the large dc-blocking capacitor in the signal path of traditional audio channels by selecting a stereo-headphone amplifier, such as the MAX9724A or MAX9789A from Maxim (www.maximic.com). The MAX9789A includes a speaker amplifier, headphone amplifier, and low-dropout regulator. Those devices feature Maxim's patented DirectDrive technology, which reduces the size and cost of a system by removing the need for bulky coupling capacitors.

Removing the capacitors also improves audio quality, because the piezoelectric effect of capacitors can add small amounts of distortion in the audio path. What's more, charge buildup in the capacitors often causes annoying clicks and pops at the output when you exercise power or shutdown. To avoid these problems, remove the capacitors and install the MAX9789A, which includes a 2W Class AB stereo-speaker amplifier, DirectDrive capless stereo-headphone amplifiers, and a low-dropout regulator to power the analog portion of the HDA codec, whose typical PSRR (power-supply-rejection-ratio) performance is poor. Audio quality at the MAX9789A headphone amplifiers exceeds requirements of the Vista operating system (**Table 2**).

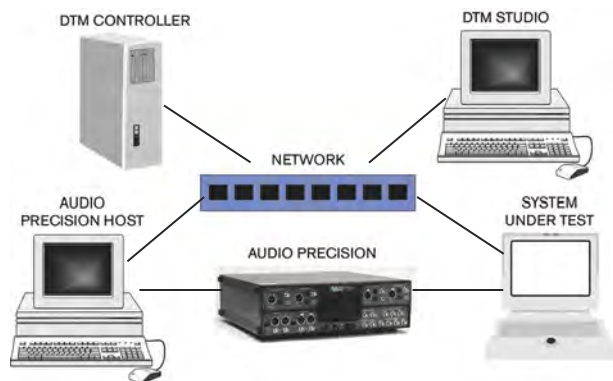

Figure 1 Microsoft's DTM (device-test manager) enforces a subset of device requirements for the WLP (Windows Logo Program). Microsoft will add additional performance tests to the DTM in the future.

THD+N

The first audio specification that the DTM monitors is THD+N, which quantifies the amount of nonlinearity present in a system, in the broad sense that nonlinearities are any audio-output components that are not part of the original in-

TABLE 1 WLP REQUIREMENTS AT THE ANALOG-OUTPUT JACK FOR PREMIUM MOBILE DEVICES

Device type	Requirement	Value	Frequency range
Analog-line-output jack	THD+N	≤ -65 dBFS	20 Hz to 20 kHz
	Dynamic range with signal present	≤ -80 dBFS A-weight	20 Hz to 20 kHz
	Magnitude response	≤ ±0.25-dB-ripple (0.5 dB p-p delta), 1 dB at upper-band edge, 3 dB at lower-band edge	20 Hz to 20 kHz
	Sampling-frequency accuracy	0.02%	
	Line-output crosstalk	≤ -50 dB	20 Hz to 15 kHz
	Full-scale output voltage	≥0.707V rms	
	Noise level during system activity	≤ -80 dBFS A-weight	
	Interchannel phase delay	30° or 12.5 μsec, whichever is greater	20 Hz to 20 kHz
Analog-head-phone-output jack	THD+N	≤ -65 dBFS ≤ -45 dBFS at 32Ω	100 Hz to 20 kHz
	Dynamic range with signal present	≤ -80 dBFS A-weight ≤ -60 dBFS at 32Ω	100 Hz to 20 kHz
	Magnitude response	≤ ±0.25-dB-ripple (0.5 dB p-p delta), 1 dB at upper-band edge, 3 dB at lower-band edge	100 Hz to 20 kHz
	Sampling frequency accuracy	0.02%	
	Line output crosstalk	≤ -50 dB	20 Hz to 15 kHz
	Full-scale output voltage	≥0.707V rms at 320Ω, ≥300 mV rms at 32Ω	
	Noise level during system activity	≤ -80 dBFS A-weight	
	Interchannel phase delay	30° or 12.5 μsec, whichever is greater	20 Hz to 20 kHz

Note: Microsoft’s Web site contains a complete listing of WLP-device requirements.

put signal. Harmonic distortion tends to color the audio signal, making it sound unnatural. Noise is the residual low-level hiss or hum that you hear in quiet periods of the audio soundtrack. Thus, a THD+N measurement is important to end users be-

cause it quantifies the level of precision to which a system reproduces an audio signal.

The THD+N measurement is a ratio of the sum of harmonics and noise (with the amplitude of the fundamental frequency removed) to the fundamental. You can express it as a percentage or in decibels referenced to an amplitude. WLP, for instance, defines THD+N in units of dBFS (decibels full-scale). **Figure 3** shows the THD+N measurement in an audio analyzer. The voltage at M2 is the sum of the harmonics plus noise, minus the amplitude of the fundamental frequency, and the voltage at M1 is the amplitude of the fundamental frequency only. To produce a graph of THD+N versus frequency, the analyzer repeatedly makes this measurement as its sinusoidal input sweeps over the audio-frequency range.

Three main factors contribute to a THD+N failure. First are the active components, which include the HDA codec or the audio amplifier. Second are the passive components, including capacitors and ferrite beads, and third is the layout,

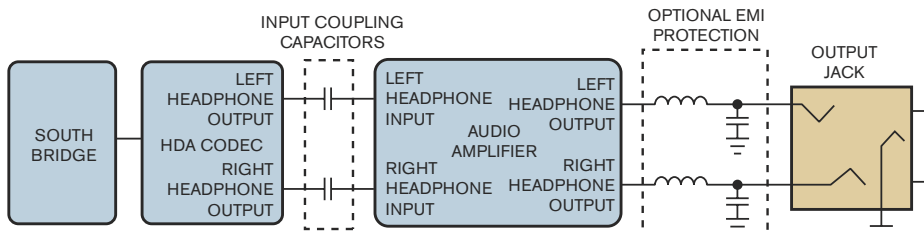

Figure 2 The Microsoft DTM measures electrical performance of the entire signal path for the headphone amplifier.

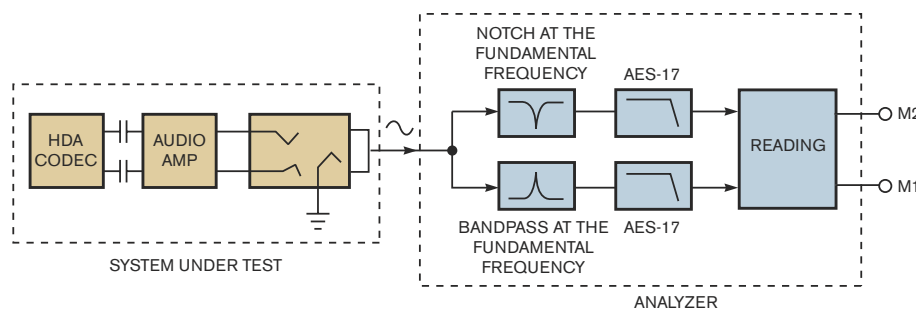

Figure 3 THD+N is the ratio of the amplitude at M2 referenced to the amplitude at M1, represented in log scale: $THD+N (dBra) = 20 \times \log(V_{M2(RMS)} / V_{M1(RMS)})$. The drawing shows the bandpass filter at the fundamental frequency for conceptual reasons. Some analyzers may not use this block in the THD+N measurement.

TABLE 2 WLP REQUIREMENTS FOR PREMIUM MOBILE DEVICES VERSUS MAX9789A SPECS

Device type	Requirement	Windows Premium Mobile Vista specifications	MAX9789A/MAX9790A specifications
Analog-line-output jack, $R_L=10\text{ k}\Omega$	THD+N	$\leq -65\text{ dBFS}$	-94 dBFS (20 Hz to 20 kHz)
	Dynamic range with signal present	$\leq -80\text{ dBFS A-weighted}$	$-97\text{ dBFS A-weighted}$
	Line-output crosstalk	$\leq -50\text{ dB}$ (20 Hz to 15 kHz)	-77 dB (20 Hz to 15 kHz)
Analog-head-phone-output jack, $R_L=32\Omega$	THD+N	$\leq -45\text{ dBFS}$ (100 Hz to 20 kHz)	-77 dBFS (20 Hz to 20 kHz)
	Dynamic range with signal present	$\leq -60\text{ dBFS A-weighted}$	$-89\text{ dBFS A-weighted}$
	Headphone-output crosstalk	$\leq -50\text{ dB}$ (20 Hz to 15 kHz)	-74 dB (20 Hz to 15 kHz)

Note: THD+N, dynamic range, and crosstalk are measured in accordance with AES-17 audio-measurement standards.

which almost always focuses attention on grounding practices. Given a graph of THD+N versus frequency, you can easily identify one of these contributors as the root cause of failure by noting characteristics in the graph.

In general, the THD+N performance of active components degrades at high frequencies. For failures that an active compo-

nent causes, therefore, the component's THD+N curve typically fails only at high frequencies. Notice that THD+N is expressed in units of dBrA, where A is defined as 1V rms (system full-scale output voltage) at the audio analyzer. If THD+N fails only at high frequencies (**Figure 4a**), turn to the component's evaluation kit, which the semiconductor vendor supplies, and evaluate the component to obtain a baseline measurement. This exercise may reveal that the selected active component is not Vista- or WLP-compliant. If it fails the Vista requirements for THD+N, you should use one of the latest Vista-compliant amplifiers, such as the MAX9789A from Maxim.

A THD+N failure at only low frequencies typically points to the quality and physical size of the input coupling capacitor. In **Figure 4b**, notice how the curve for X5R dielectric begins to rise at approximately 100 Hz, whereas the X7R dielectric remains relatively flat down to 20 Hz.

The piezoelectric effect of the input coupling capacitors can contribute nonlinearities in the signal path that are prominent at low frequencies. To minimize the THD that piezoelectric action causes, choose input coupling capacitors with a higher voltage rating and better dielectric. If you require a ceramic input coupling capacitor, for example, select one with a high voltage rating and an X7R dielectric.

Ferrite beads are other passive components inline with the audio-signal path that can increase THD. If a system fails THD+N across the entire audio band, a typical cause is the quality of the ferrite bead. Notice in **Figure 4c** that the green curve with the ferrite bead, which represents a low-quality ferrite bead in series with the audio path, is almost an upward translation of the blue curve without the ferrite bead.

You typically insert ferrite beads between the audio amplifier and the output jack. In conjunction with a small capacitor to ground, the bead then forms a filter for ESD (electrostatic-discharge) or EMI (electromagnetic-interference) protection. If a system that fails THD+N

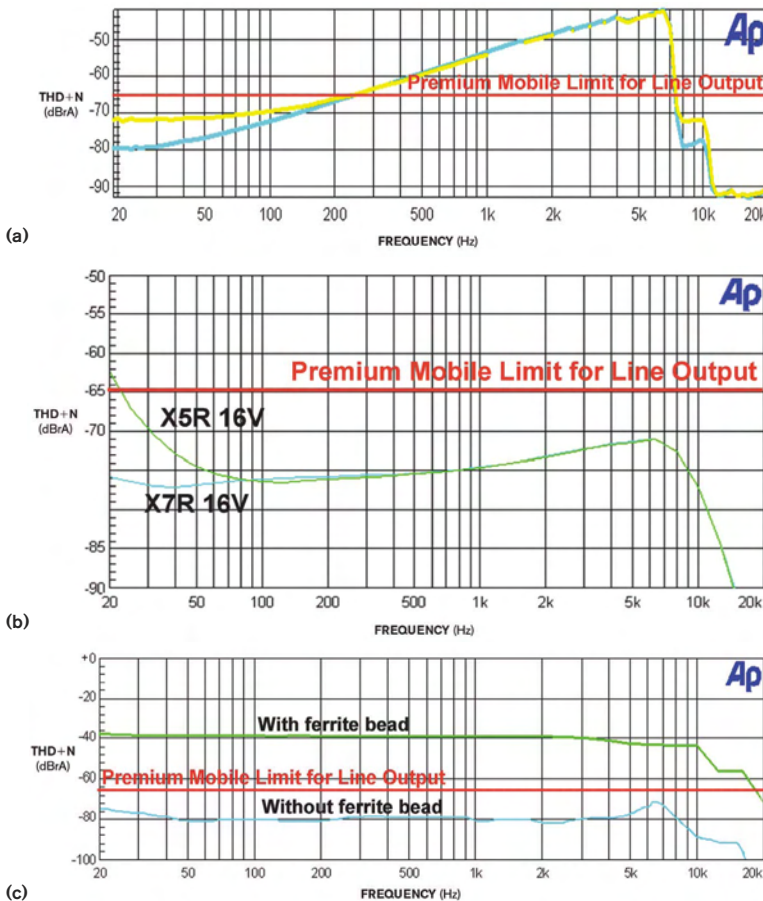

Figure 4 THD+N is recorded at constant output amplitude as you sweep the input-signal frequency from 20 Hz to 20 kHz (a). The piezoelectric effect of the input coupling capacitors can contribute signal-path nonlinearities prominent at low frequencies (b). Ferrite beads inline with the audio-signal path can increase THD (c).

across the entire audio band includes this optional EMI-protection circuit, temporarily replace the ferrite bead with a 0Ω resistor and remeasure the THD+N. Most likely, THD+N will improve across the audio band and confirm ferrite beads as the cause of failure. **Table 3** lists ferrite beads compliant with the Vista requirements for premium mobile devices. All have been tested in-circuit for THD+N.

TABLE 3 COMPLIANT FERRITE BEADS

Manufacturer	Part no.
Murata	BLM18BD601SN1
TDK	MMZ1608Y601BTA
Taiyo Yuden	LFBK1608HM601

If active components in the system under test are Vista-compliant and you use high-quality passive components in the signal path, then layout is the most likely cause of failure. In that case, noise, rather than distortion, usually dominates the THD+N measurement. A simple FFT (fast-Fourier-transform) plot can confirm that presumption.

If noise dominates the THD+N measurement, the most likely culprit is the grounding of the HDA codec and audio amplifier. To ensure optimum performance, you must reference the codec's analog ground to the same quiet ground as that of the audio amplifier. Any difference in these ground potentials can add noise to the signal path. Reference the two analog grounds to each other, such that any movement at the codec output also appears at the input of the audio amplifier, thus producing a net voltage difference of 0V.

ground return does not pass through sensitive analog circuitry. These simple precautions can reduce or eliminate headaches later in the design cycle.

FULL-SCALE OUTPUT VOLTAGE

The DTM also monitors full-scale output voltage, which is the voltage level you measure at the output jack when you configure the codec with all zeros. The DTM specifies a minimum voltage at the output jack for WLP devices. Full-scale voltage is important, because it ensures that the end user can, for example, comfortably listen to DVDs in a noisy environment, such as on an airplane.

To avoid lawsuits based on hearing damage, the industry recently set restrictions on the upper limit of this specification. You should therefore keep in mind that a maximum output-voltage specification may accompany the minimum output-voltage specification, especially for products manufacturers ship to France or Germany.

If a system fails the output-voltage specification, its signal path includes some source of attenuation. Such attenuation can occur in the codec output, the audio-amplifier output, or the output jack (**Figure 5**). You can easily confirm a problem in the codec or codec driver by probing between the codec's HDA outputs and the input coupling capacitors. If an oscilloscope does not show a full-scale signal at that point, the problem is most likely in the codec driver.

Next, inspect the audio-amplifier output. An improperly configured external gain for the audio amplifier may account for the output attenuation. To check the external gain, you should confirm that the feedback resistance is greater than or equal to the input resistance.

Now, examine the output jack. If you measure full-scale output voltages at the first two locations but a reduced signal at the output jack, you most likely have inserted series resistors between the audio amplifier and the output jack. Series resistors form a voltage divider with the load at the output jack, so testing with a 32Ω load rather than a $10\text{-k}\Omega$ load exagger-

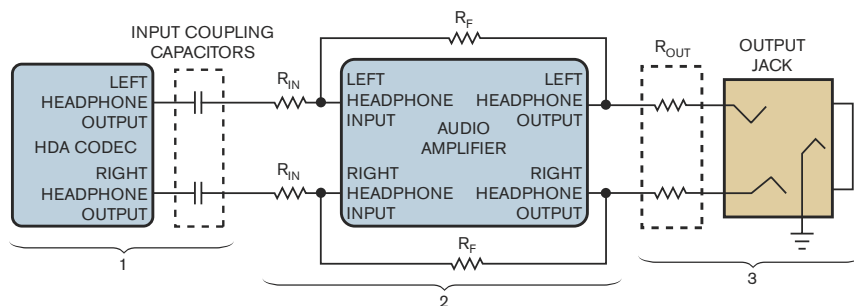

Figure 5 You can partition the headphone amplifier's signal path into three sections when troubleshooting failures of the full-scale output voltage.

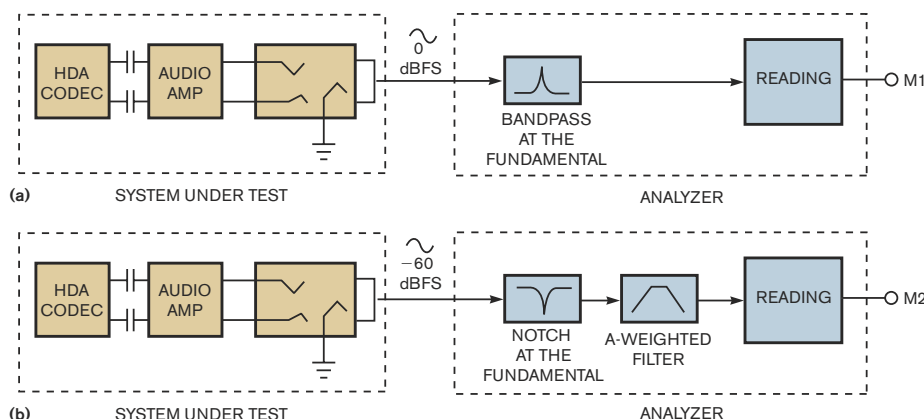

Figure 6 Dynamic range is the ratio of full-scale output voltage to the weighted rms-noise floor: $\text{Dynamic range (dB)} = 20 \times \log(V_{M2(\text{RMS})}/V_{M1(\text{RMS})})$ (a). You measure the noise floor in the presence of a -60-dBFS signal, which you then notch out of the noise-floor measurement (b).

ates the attenuation effect. To remove the attenuation, replace the series resistors with 0Ω resistors.

DYNAMIC RANGE

Dynamic range is another audio specification that the DTM electrically monitors. Dynamic range with signal present is the ratio of the weighted-rms-noise floor over the full-scale reference level. You record the weighted-noise-floor measurement in the presence of a -60 -dBFS signal and then you notch out the -60 -dBFS signal from the analyzer's dynamic-range reading.

Figure 6 shows the dynamic-range measurement in an audio analyzer. Dynamic range is the ratio of the weighted-rms-noise floor over the full-scale output. The voltage at M1 is the full-scale output voltage measured at the output jack, and the voltage at M2 is the weighted-rms-noise floor, minus the fundamental frequency of the -60 -dBFS test signal. You express the units in decibels.

The two main contributors to a dynamic-range failure are attenuated output level and elevated noise floor. If a system's full-scale output voltage is acceptable, the system is halfway to Vista compliance in dynamic range. First, confirm that the output-jack voltage meets the full-scale requirement. If not, determine where attenuation occurs in the signal path.

If the system reproduces a full-scale signal at the output jack, noise limits the dynamic-range measurement. Before troubleshooting the noise source, confirm that active components in the system are Vista-compliant with respect to noise.

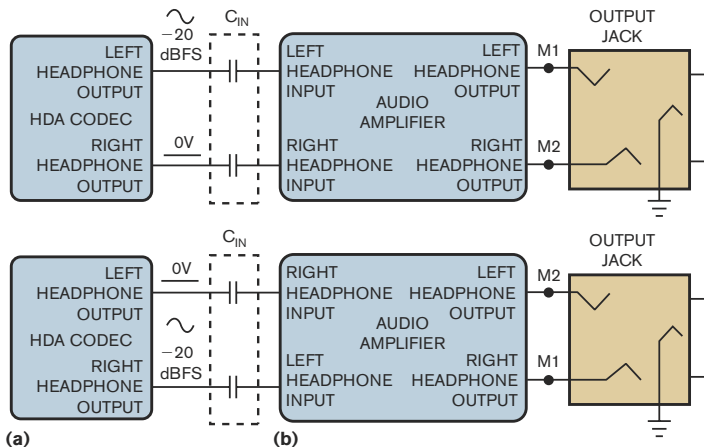

Figure 7 Crosstalk from the left channel to the right channel (a) over the signal measured on the right channel (a) over the signal measured on the left channel (b): $\text{Crosstalk (dB)} = 20 \times \log(V_{M2(\text{RMS})}/V_{M1(\text{RMS})})$.

(You can usually find this specification in the electrical-characteristics table of the device's data sheet.) Otherwise, turn to evaluation kits for the active devices, and record baseline measurements.

If noise dominates the system's dynamic-range measurement and its active components are Vista-compliant, the PCB layout is usually to blame. The main pitfall in layout is the grounding. To ensure optimum performance, reference the analog ground of the HDA codec to the same quiet ground as

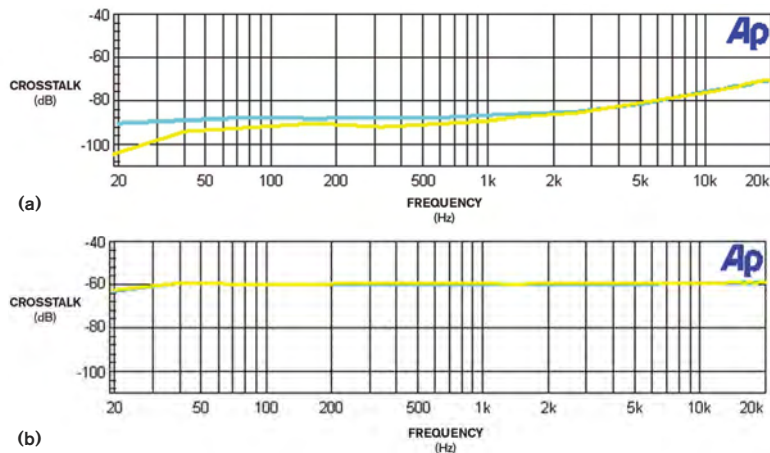

Figure 8 If a crosstalk measurement produces a positive slope as you sweep the frequency from 20 Hz to 20 kHz, the system most likely has capacitive coupling at the inputs of the audio amplifier (a). If the system has a shared resistive ground return, the crosstalk measurement is relatively flat across the audio band (b).

the audio amplifier. A difference in these ground potentials can add noise to the signal path.

If, after optimizing IC placement to achieve a common, quiet analog ground for the HDA codec and audio amplifier, you achieve no improvement, you must work further to isolate the noise source. First, confirm that system noise, including fan

noise, hard-disk-drive noise, and other contributors, is not coupling into the amplifier inputs. If such noise is present, the audio amplifier can amplify it and pass it to the output jack. Second, confirm whether you have referenced the ground pin of the output jack to the same analog ground as the analog portion of the HDA codec and audio amplifier. Again, a difference in these ground potentials can add noise to your signal path.

CROSSTALK

Crosstalk is an audio specification that the DTM does not yet enforce, but it is likely to do so in the near future. Crosstalk quantifies the amount of signal that couples from one channel to another. An ideal stereo-signal path would have no crosstalk between channels, but parasitics in the IC and PCB layouts guarantee some minimum level of crosstalk. You must minimize crosstalk to ensure a true stereo image at the outputs.

Two conditions define stereo crosstalk: from left channel to right channel and from right channel to left channel. A measurement from left to right takes the ratio of the signal measured on the right channel over the signal measured on the left channel (**Figure 7**). During this measurement, the signal on the right channel is 0V, and the left-channel input of -20 dBFS sweeps across the audio band. You express the

crosstalk measurement in decibels.

The top contributor to crosstalk failures is layout, whether of the IC or the PCB. Given the crosstalk limits of WLP 3.0— ≤ -50 dB between 20 Hz and 15 kHz—a crosstalk failure is rarely due to the IC layout. Maxim's MAX9789A, for example, has a crosstalk specification of ≤ -77 dB into a 10-k Ω load, across the entire audio band. (It's always a good idea, however, to confirm the baseline-crosstalk measurement using an evaluation kit for the active component.) The main cause of crosstalk failure is almost always the PCB layout: either capacitive coupling between the inputs or a shared resistive ground return at the output jack.

If a crosstalk measurement has a positive slope as you sweep frequency from 20 Hz to 15 kHz, the system has capacitive coupling at the audio-amplifier inputs (**Figure 8a**). Capacitive coupling becomes apparent when you apply a high-impedance drive at the audio-amplifier inputs. The high impedance can originate in an improperly configured codec driver. You should therefore be sure to configure the HDA-codec outputs for a 1 to 2 Ω output drive. Otherwise, you can configure the codec for a low-impedance drive state.

If external resistors set the amplifier gain, ensure that the series resistor, R_{IN} , is as close as possible to the amplifier inputs, so that a low-impedance source drives the amplifier. If you configure the system for low-impedance drive and its crosstalk measurement still fails at 15 kHz, you may have routed the stereo inputs too close together. To provide optimum stereo separation, insert a solid ground fill between the amplifier inputs.

If the crosstalk measurement is relatively flat across the audio band yet fails the crosstalk specification, the typical cause is a shared resistive-ground return (**Figure 8b**). Avoid a shared return by ensuring minimal resistance in the return path for the output jack's ground connection. Short out any series resistors in the path, locate audio amplifiers close to the output jack to minimize the length of the ground return, and minimize contact resistance to the sleeve of the output jack itself. These concepts also apply to the ground-return path to the HDA codec.

MAGNITUDE RESPONSE

The WLP also specifies criteria for the magnitude response. Magnitude response is a measurement of the system's output voltage over a given frequency range. You typically reference this response to the system's full-scale signal level and express it in decibels. Magnitude response is important because it specifies the audio bandwidth the system can reproduce.

You measure magnitude response by sweeping a constant-amplitude pure tone of -20 dBFS through the audio bandwidth. You measure the output level relative to the output level at 997 Hz.

The system's equalization circuitry, which can cause inaccurate-response measurements by boosting or suppressing certain frequencies within the measurement bandwidth, can cause a failure in magnitude response. When measuring a system for

MORE AT EDN.COM 

 Go to www.edn.com/ms4282 and click on Feedback Loop to post a comment on this article.

magnitude response, be sure to disable the system-equalization circuitry.

Other possible causes of magnitude-response failure are the passive components, which can form a filter that affects high or low frequencies. If the system fails at high frequencies, confirm that any feedback capacitors around the headphone amplifier are not limiting the magnitude response. The feedback resistors, too, can cause unanticipated attenuation in the audio bandwidth. A simple $1/(2\pi RC)$ calculation can reveal whether this is the case. Remember to account for tolerance in the passive-component values.

If the system fails at low frequencies and your headphone amplifier requires large dc-blocking capacitors at the output, select an output-capacitor value that ensures that the system is Vista-compliant for both 32Ω and $10\text{-k}\Omega$ loads. Again, be sure to account for tolerance in the value of the dc-blocking capacitor.

If the system fails at low frequencies even though its headphone amplifier does not require dc-blocking capacitors before the output jack, as is the case with Maxim's MAX9724A, for instance, check that the values of the input coupling capacitors are Vista-compliant. And remember to account for tolerance when selecting values for the input coupling capacitors and resistors.

INTERCHANNEL-PHASE DELAY

Interchannel-phase delay is a Vista specification that Microsoft only recently added to the DTM program. For stereo

devices, it is the measured phase difference between left and right channels, which you express in degrees or microseconds as a function of frequency. You obtain interchannel phase delay by measuring the relative phase difference between the stereo-audio outputs while sweeping the audio signal from 20 Hz to 20 kHz.

If a system fails the requirements for interchannel-phase delay, there may be an insufficiently tight tolerance on the passive-component values inline with the stereo channels. There may be a mismatch, for example, in values for the left- and right-channel input coupling capacitors. If, on the other hand, the passive components have sufficiently tight tolerances, there may be something wrong in the digital domain. Some system block within the active component may be functioning improperly.

To help you with Vista-compliance troubleshooting, Maxim has generated an online tool that presents system engineers with a decision tree for determining the cause of system failures. Find it at www.maxim-ic.com/fidelity-debug-tool. **EDN**

AUTHOR BIOGRAPHY



Kimberly Christman (Schmidt) is a corporate applications engineer at Maxim Integrated Products, specializing in audio-design support and product definition for the multimedia-business unit. She has a bachelor's degree in electrical engineering from the University of California—Los Angeles.