

HP-82B

SPECIFICATIONS

ACOUSTIC & ELECTRICAL SPECIFICATIONS:

- Nominal Impedance: 8 ohm
- Max Amp Power: 150W
- Frequency Range: 48 Hz – 22 kHz (-6 dB)
- Sensitivity: 90 dB SPL, 1 Watt @ 1 Meter
- Crossover Frequency: 3000Hz

SYSTEM COMPONENTS:

- Cabinet: 331002-001
- Grille: 330240-001
- Low Frequency Transducer: 8 in. (200mm) Fiber Laminate 325757-001
DC Resistance: 5.8 ohm \pm 10% Copper Wire
- High Frequency Transducer: 1 in. (25mm) Pure Titanium Dome 325792-001
DC Resistance: 3.6 ohm \pm 10% Copper Wire
- Crossover Network: 331006-002

AURAL SWEEP TEST SPECIFICATIONS:

- A. System Aural Sweep Test: 6.0V Input, 20 Hz to 20 kHz
- B. L.F. Aural Sweep Test: 6.0V Input, 20 Hz to 2.7 kHz
- C. H.F. Aural Sweep Test: 2.83V Input, 2kHz to 20 kHz

PHYSICAL SPECIFICATIONS:

- Enclosure Dimensions: 19.87 x 11.5 x 912 in.D
(501mm x 292mm x 232mm D)

SHIPPING WEIGHT:

49 lbs. (22.2 kg.) (In Pairs)

WARRANTY INFORMATION:

- Refer to Warranty Statement packed with each product.

PACKAGE

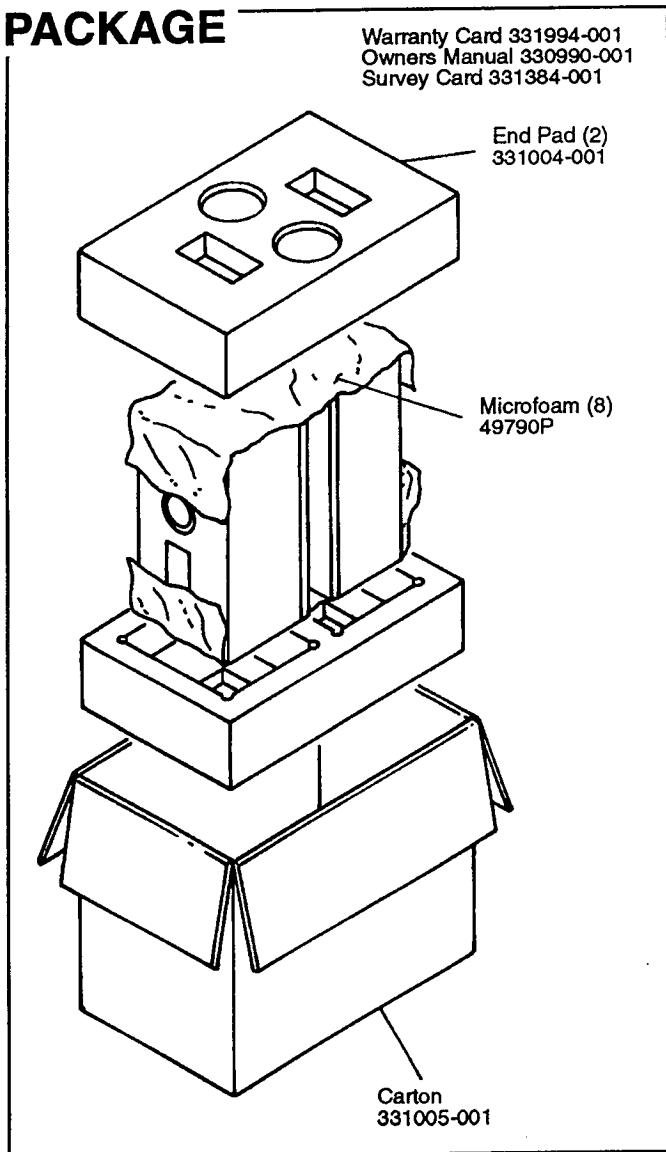

WIRING DIAGRAM

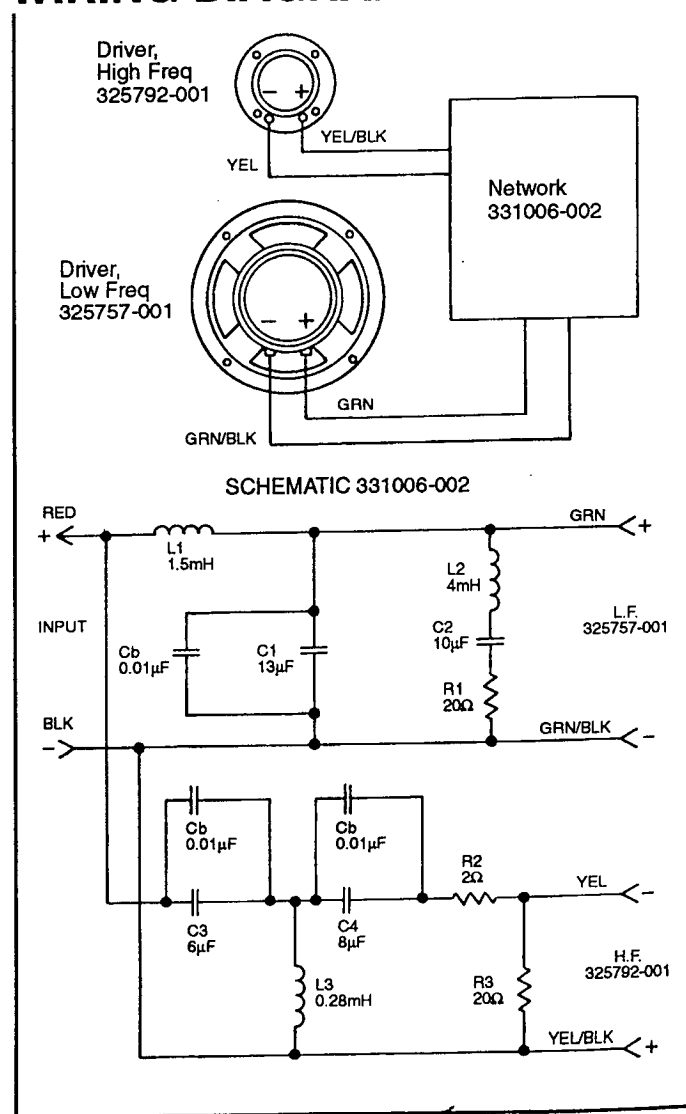

HP-82B

HP-82B

COMPONENT EXPLODED VIEW

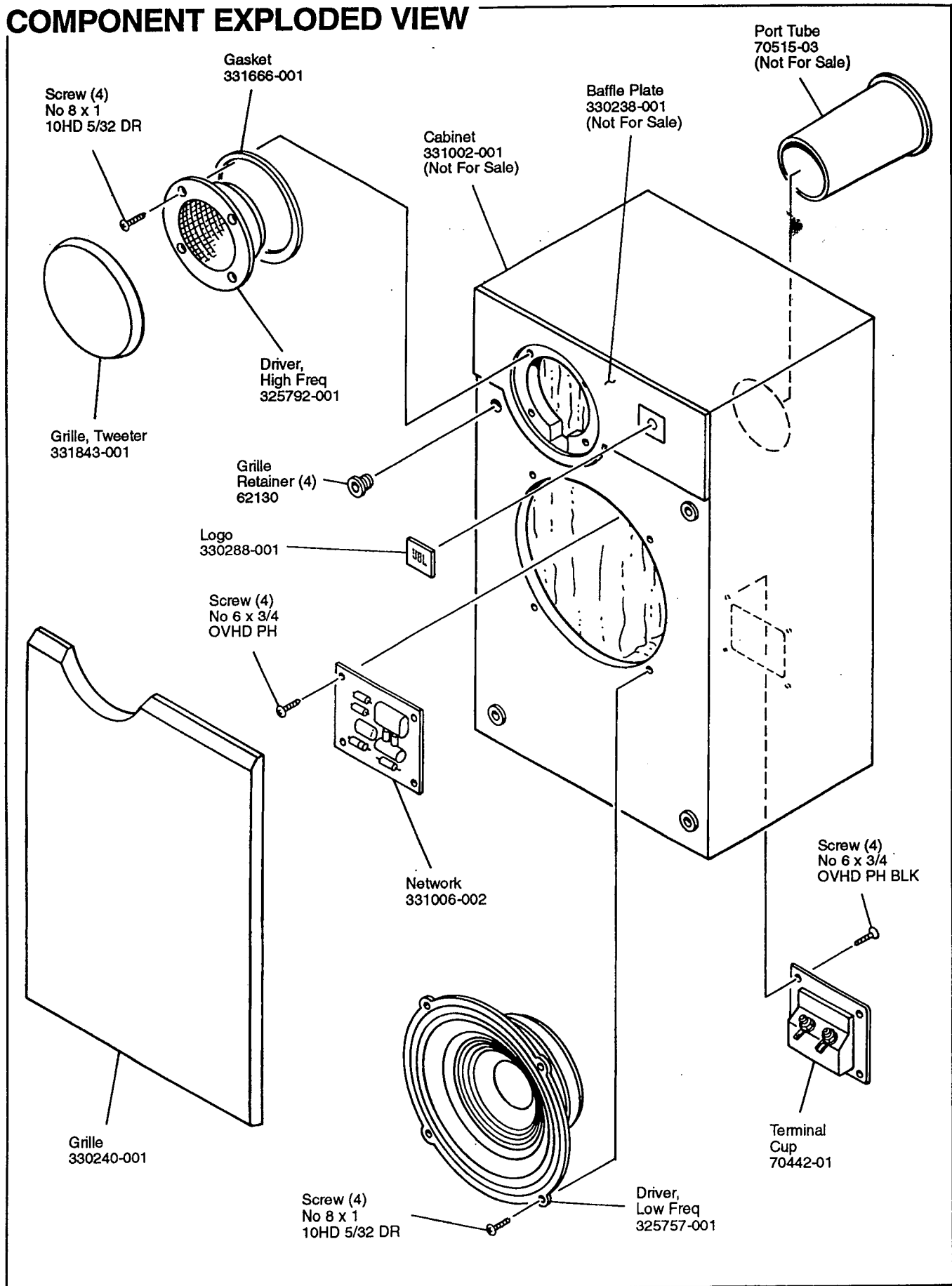

HP-82B