



J520M

SPECIFICATIONS

ACOUSTIC & ELECTRICAL SPECIFICATIONS:

- Nominal Impedance: 8 ohm
- Recommended Amp Power: 10W to 75W
- Frequency Response: 70 Hz to 20 kHz (-6dB)
- Sensitivity: 87 dB SPL*
- Crossover Frequency: 4.5 kHz

SYSTEM COMPONENTS:

- Cabinet: CJ520M (Not For Sale)
- Grille: GJ520M (305084-001)
- Low Frequency Transducer: P205G 5 in. (130mm) Nitrile Polymer Fibre Cone (76431)
- DC Resistance: 4.6 ohm $\pm 5\%$

*1 Watt @ 1 Meter

SYSTEM COMPONENTS: (cont'd)

- High Frequency Transducer: (10mm) Composite Dome Transducer 305062-001
- DC Resistance: 5.5 ohm $\pm 10\%$
- Crossover Network: 301931-001

AURAL SWEEP TEST SPECIFICATIONS:

- A. System Aural Sweep Test: 5.0V Input, 20 Hz to 20 kHz
- B. L.F. Aural Sweep Test: 4.0V Input, 50 Hz to 5000 Hz
- C. H.F. Aural Sweep Test: 2.0V Input, 1 kHz to 20 kHz

PHYSICAL SPECIFICATIONS:

- Enclosure Dimensions: 12.0 x 7.5 x 8.5 in. D (305mm x 190mm x 216mm D)
- Shipping Weight: 18 lbs. (8.2 kg.) Pair

WARRANTY INFORMATION:

- Refer to the Warranty Statement packed with each product.

PACKAGE

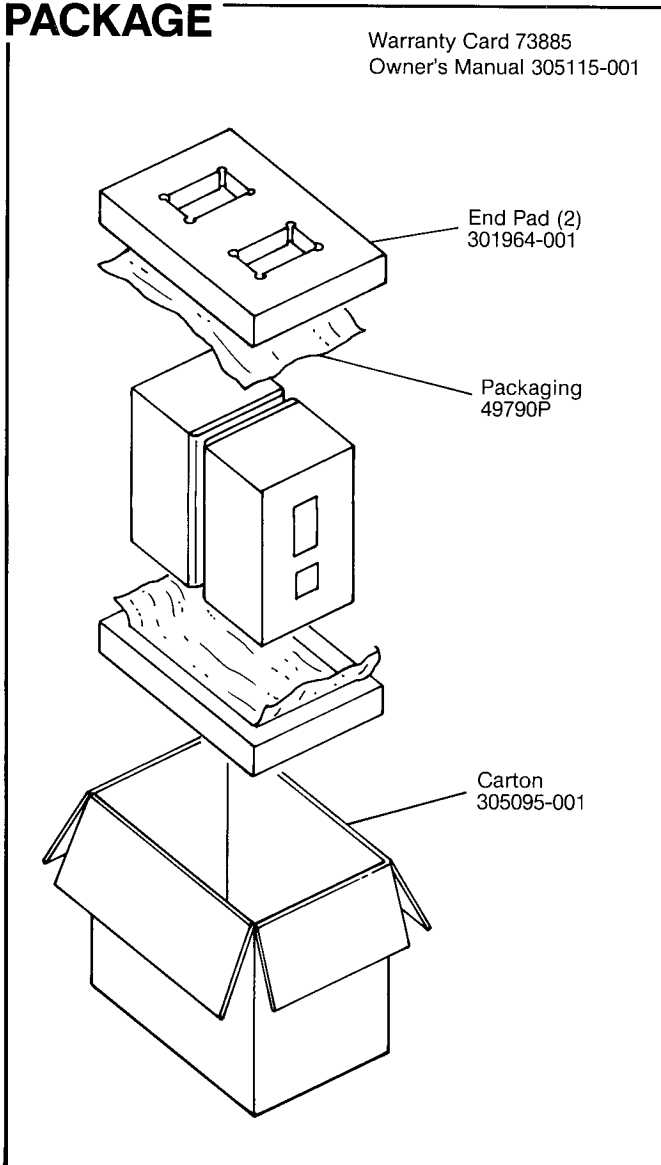

WIRING DIAGRAM

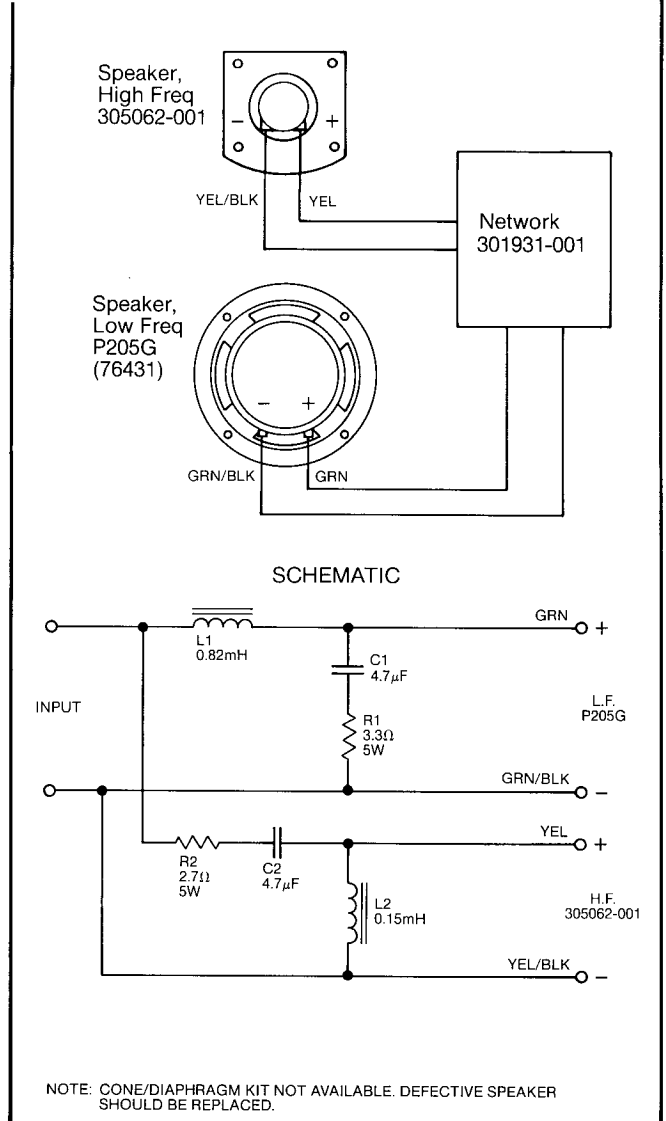

J520M

J520M

COMPONENT EXPLODED VIEW

