

L9000



SPECIFICATIONS

ACOUSTIC & ELECTRICAL SPECIFICATIONS:

- * Nominal Impedance: 4 ohm
- * Recommended Amp Power: 50-300W
- * Frequency Response: 70 Hz - 20 kHz (± 2 dB)
- * Sensitivity: 90 dB / 2,83V / 1 m
- * Crossover frequency: 400HZ / 2,5 kHz

SYSTEM COMPONENTS:

- * Cabinet: CL9000 (Not for sale)
- * Grille: GL9000 (2407450)
- * Woofer: LE120H 300mm Woofer
75mm voice coil
- DC Resistance: 5,9 ohm
- * Midrange: 705G 130mm Midrange
30mm voice coil

SYSTEM COMPONENTS: (cont'd)

- DC Resistance: 4,4 ohm
- * Tweeter: 050TI 25mm
Titanium Dome Tweeter
- DC Resistance: 3,8 ohm
- * Crossover Network: NL9000 (2707440)

PHYSICAL SPECIFICATIONS:

- * Enclosure Dimensions (H.W.D): 15,7x23,6x13,4 in. D
(400x600x340mm D)
- * Shipping Weight: 59 lbs. (27 kg.)

WARRANTY INFORMATION:

- * Refer to the Warranty Statement packed with each product

PACKAGE

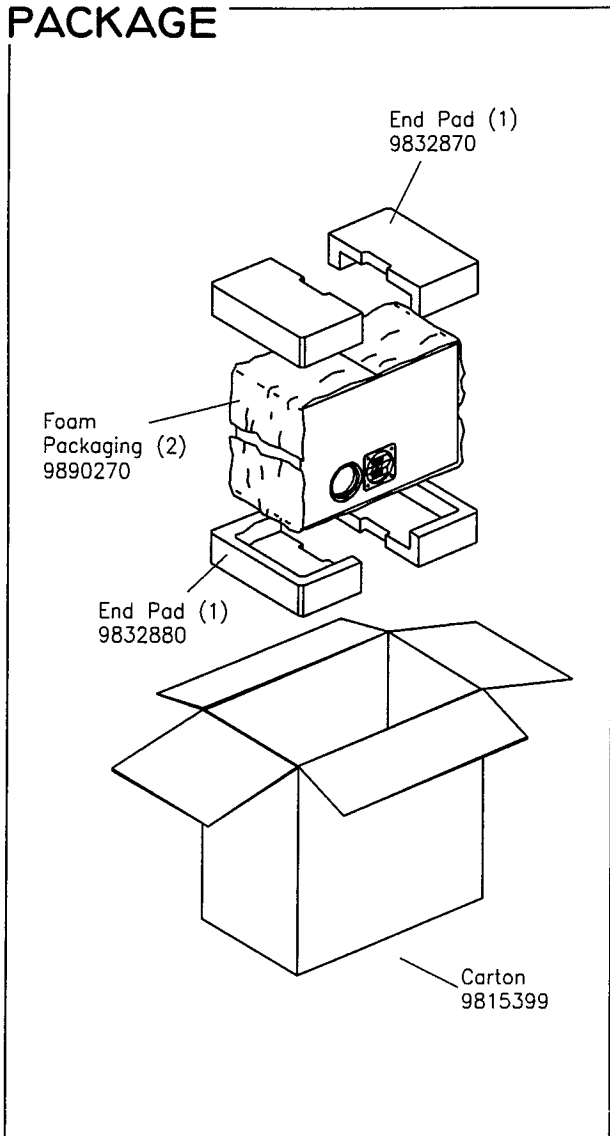

WIRING DIAGRAM

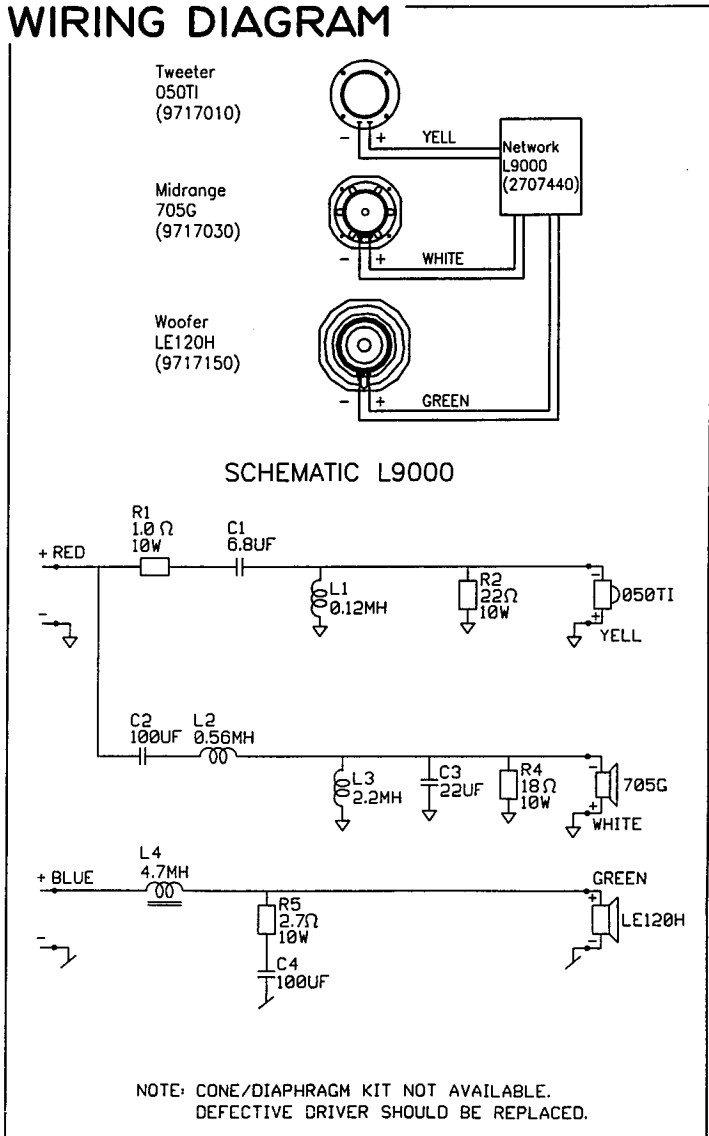

L9000

Valid from serial no. 01001
Rev. 28/3-1996

L9000

COMPONENT EXPLODED VIEW

