

S3100 L,R

SPECIFICATIONS

ACOUSTIC & ELECTRICAL SPECIFICATIONS:

- Nominal Impedance: 6 ohm
- Max. Recommended Amp Power: 400W
- Frequency Response: 32 Hz to 20 kHz (-6 dB)
- Sensitivity: 94 dB SPL*
- Crossover Frequency: 750 Hz

SYSTEM COMPONENTS:

- Cabinet: CS3100 (316308-001) Left (316308-002) Right
- Grille: GS3100 (316321-001) Left (316321-002) Right
- Low Frequency Transducer: ME150HS 15.0 in. (380mm)
- DC Resistance: 5.6 ohm ±10%

SYSTEM COMPONENTS: (cont'd)

- High Frequency Transducer: 2426H 1-3/4 in. (44mm) Pure Titanium Compression Driver
- DC Resistance: 3.2 ohm ±8% Aluminum Wire
- Crossover Network: NS3100 (316398-001)

AURAL SWEEP TEST SPECIFICATIONS:

- A. System Aural Sweep Test: 6.0V Input, 20 Hz to 20 kHz**
- B. L.F. Aural Sweep Test: 7.0V Input, 20 Hz to 1.2 kHz
- C. H.F. Aural Sweep Test: 2.8V Input, 400 Hz to 1.2 kHz

PHYSICAL SPECIFICATIONS:

- Enclosure Dimensions: 43.75 x 22.0 x 16.0 in. D (1111mm x 559mm x 406mm D)

SHIPPING WEIGHT:

140 lbs. (63.6 kg.)

WARRANTY INFORMATION:

- Refer to the Warranty Statement packed with each product.

*1 Watt @ 1 Meter

**Shorting bars removed. Sweep network section separately.

PACKAGE

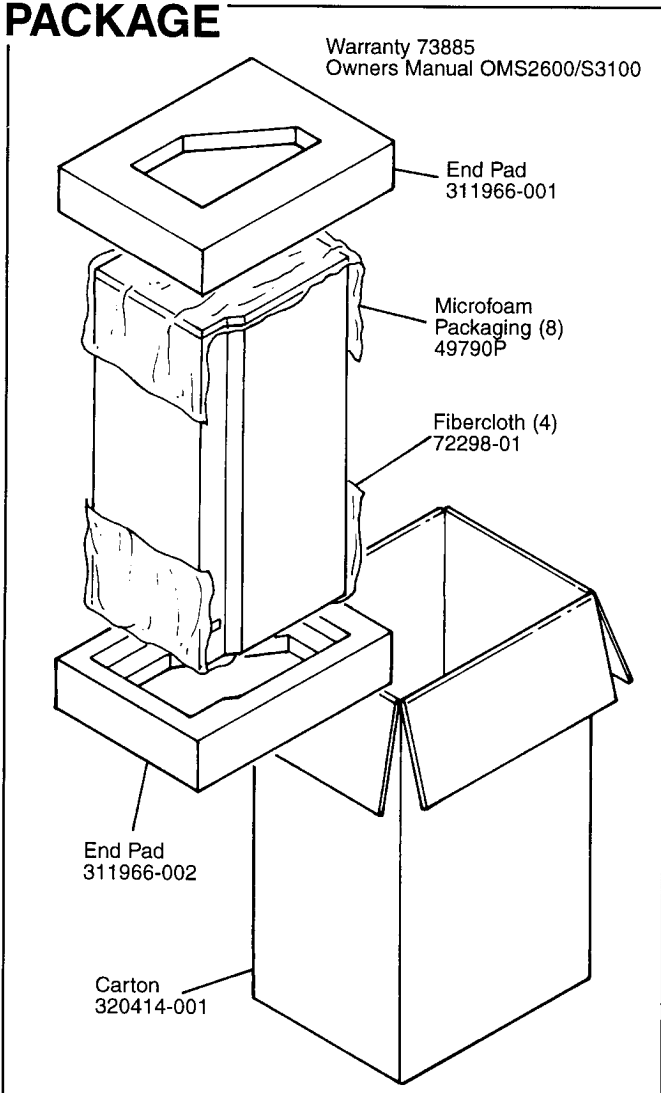

WIRING DIAGRAM

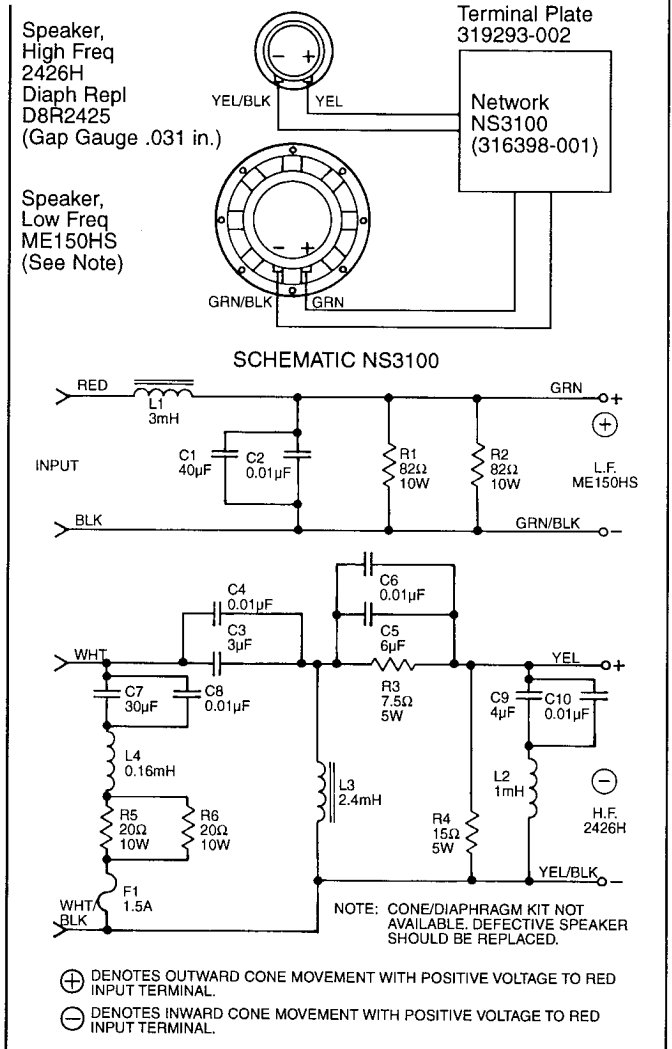

S3100 L,R

S3100 L,R

COMPONENT EXPLODED VIEW (Left S3100 Shown)

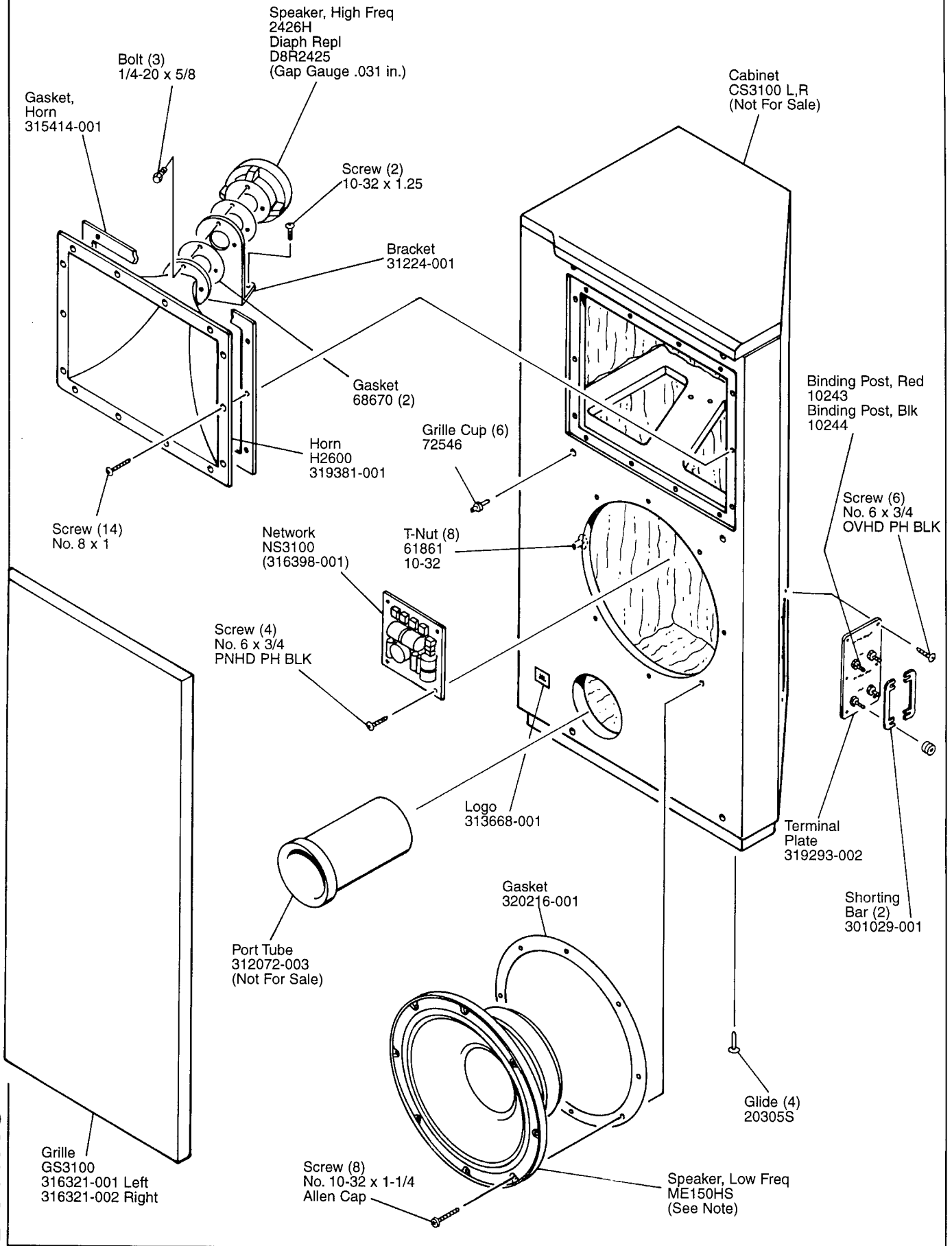

S3100 L,R