

Technical Manual



JBL SLT-1

SPECIFICATIONS

ACOUSTIC & ELECTRICAL SPECIFICATIONS:

- Nominal Impedance: 8 ohm
- Power Rating: 50W
- Frequency Response: 100 Hz to 18 kHz (± 3 dB)
- Sensitivity: 87 dB SPL*
- Crossover Frequencies: 4 kHz

SYSTEM COMPONENTS:

- Cabinet: 62862
- Grille: 62863
- Low Frequency Transducer: 135mm (5.25 in.) Cone Transducer

*1 Watt (2.83 V RMS) @ 1 Meter

SYSTEM COMPONENTS: (cont'd)

- High Frequency Transducer: 25mm (1 in.) Dome Radiator (024)
- Crossover Network: SLT-1 (62871-0060)

PHYSICAL SPECIFICATIONS:

- Enclosure Dimensions: 244mm x 159mm x 127mm D (9.62 x 6.25 x 5.0 in. D)
- Shipping Weight: 13-1/2 lbs. (6.1 kg)

WARRANTY INFORMATION:

- Refer to the Warranty Statement packed with each product.

PACKAGE

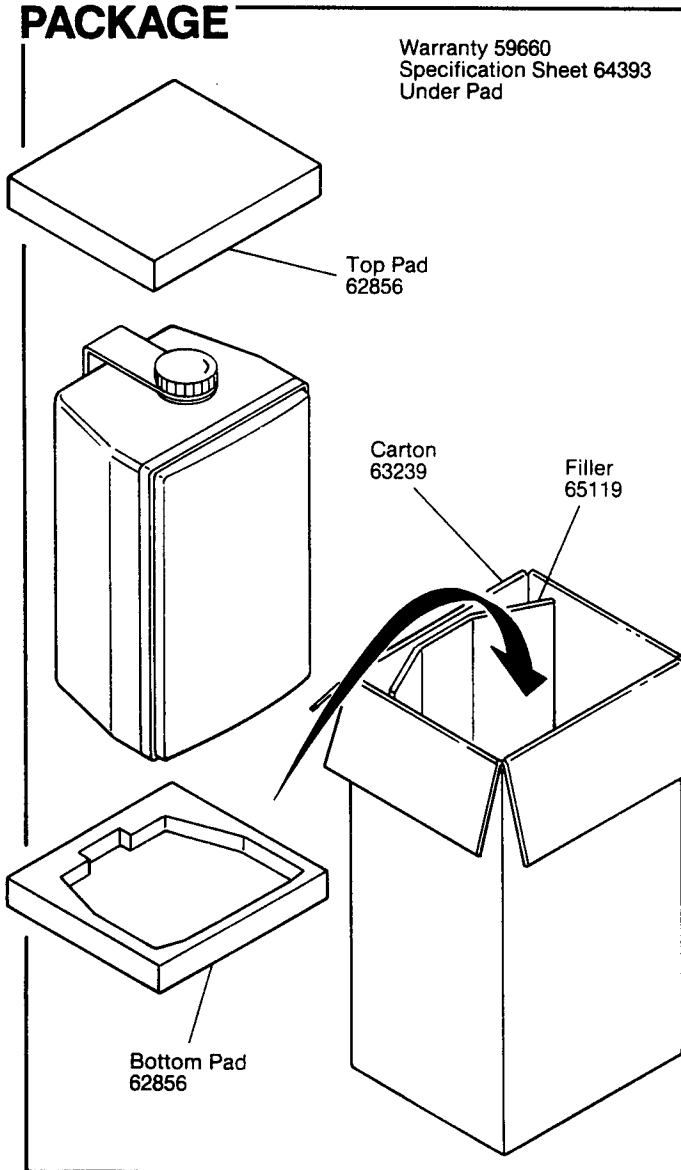

WIRING DIAGRAM

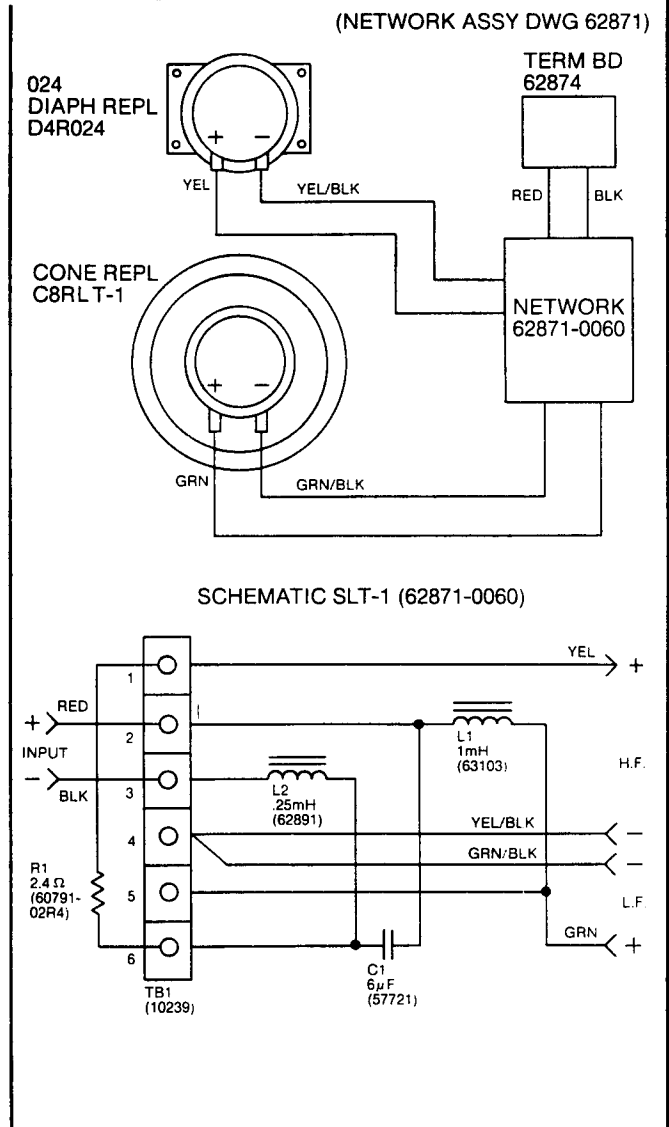

JBL SLT-1 REV B

JBL SLT-1

COMPONENT EXPLODED VIEW

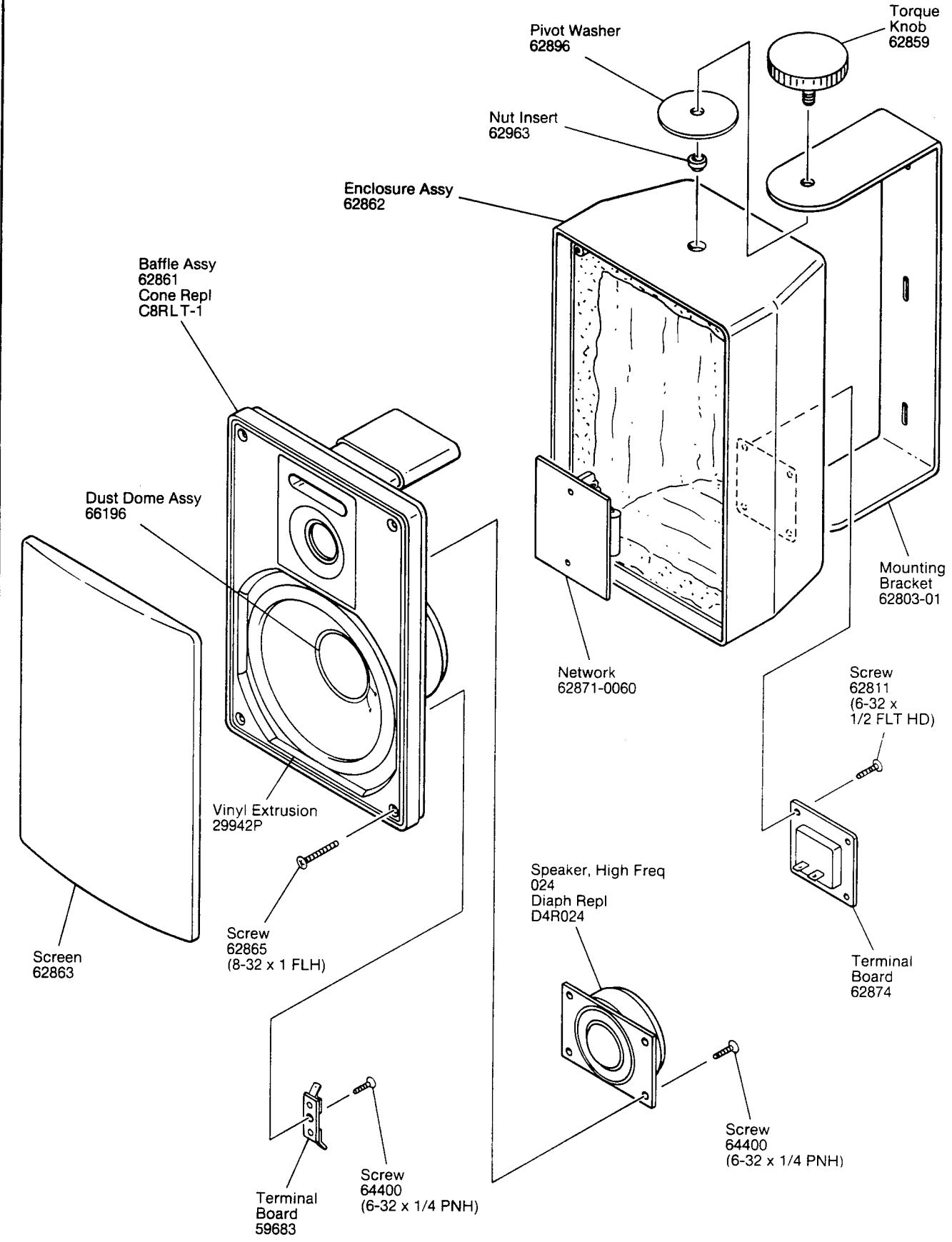

JBL SLT-1