

**NOTES:**  
 ALL SWITCHES VIEWED FROM FRONT AND SHOWN IN EXTREME COUNTER-CLOCKWISE POSITION.  
 RESISTORS ARE 1/2W, 10% COMPOSITION UNLESS OTHERWISE SPECIFIED.  
 DC INDICATES DEPOSITED CARBON TYPE.  
 W INDICATES WIREWOUND TYPE.  
 K = 1,000  
 M = 1,000,000  
 UNLESS OTHERWISE SPECIFIED: CAPACITORS LESS THAN 1 ARE UF, ALL OTHERS ARE PF. INDUCTORS INDICATED ARE UH.  
 \* VALUES ARE INDIVIDUALLY SELECTED FOR OPTIMUM RESULTS.

**MARANTZ MODEL 10B TUNER**

SCHEMATIC LAYOUT APPROXIMATES PHYSICAL LAYOUT OF UNDERSIDE OF CHASSIS EXCEPT FOR SWITCHES

SR100 SWITCH SHOWN IN CCW POSITION NO.1  
 POSITION NO.1-OFF  
 POSITION NO.2-ON  
 POSITION NO.3-DIM PANEL

SR100 SWITCH SHOWN IN CCW POSITION NO.1  
 POSITION NO.1-MUTING OFF  
 POSITION NO.2-MUTING ON

SR100 SWITCH SHOWN IN CCW POSITION NO.1  
 POSITION NO.1-TUNING  
 POSITION NO.2-LEFT/RIGHT OUTPUT  
 POSITION NO.3-LEFT/RIGHT EXTERNAL

SR100M SWITCH SHOWN IN CCW POSITION NO.1  
 POSITION NO.1-HI BLEND  
 POSITION NO.2-NORMAL  
 POSITION NO.3-MONO

RPL2 MONO SWITCH  
 RPL2 STEREO SWITCH  
 PIN #2 V15

# SERVICE BULLETIN

for serial numbers

to

subject

SERVICE ASSISTANCE ON MODEL 10B

To assist you with service problems on the Model 10B, we are enclosing the following. Please make use of these recommendations in servicing this unit.

Should undue difficulties be encountered <sup>WHERE</sup> with you are unable to repair for any reason, it is suggested that the unit be returned to the factory service facility:

8460 San Fernando Road  
Sun Valley, California 91352

PAGE 1 of 5

# SERVICE BULLETIN

model number	10B	bulletin number	69-11/10B-1	date	9-19-69
for serial numbers		to			
subject	SERVICE ASSISTANCE ON MODEL 10B				

## MARANTZ MODEL 10B CHECK-OUT

### I. To Check STEREO PHOTOSWITCH:

1. Turn the unit ON, tune in a strong stereo station.
2. Set the display switch to OUTPUT, set mode switch to NORMAL.
3. Apply forced hot air that is approximately 170° or lower (from heat gun, etc.) to the stereo photoswitch.
4. If, under these conditions, still tuned to a stereo station, the oscilloscope indicates a change to "mono" while the stereo indicator light remains lit, the switch is defective!
5. Turn the mode switch to MONO position.
6. Apply heat to mono photoswitch and observe oscilloscope display. A loss of one or both channels indicates a defective photoswitch.

### II. Check all TUBES in the IF strip and limiter for possible "GAS" conditions (V4 thru V12):

1. Disconnect the antenna to permit tuning a "dead" spot. Turn the unit ON and select a no-signal place on the band.
2. Using a VTVM on the lowest DC scale, measure the voltage from PIN 1 (grid) to GROUND on all IF tubes and limiter (V4 thru V12). Any voltage reading under such no-signal conditions indicates a defective tube!

PAGE 2 of 5

# SERVICE BULLETIN

model number 10B	bulletin number 69-11/10B-1	date
for serial numbers	to	
subject		

### III. To check STEREO SWITCHING TUBE:

1. Tune in a strong stereo station. Slowly rotate the stereo threshold pot COUNTER-CLOCKWISE.
2. If the stereo indicator light goes OUT before the pot is rotated through about 80% of its counter-clockwise direction, V14 is defective! NOTE: In some cases the light may not go out at all. This is acceptable. Once out, CLOCKWISE rotation beyond the point of light-dimming may be necessary to restore the light. This is also normal.
3. After this test, return the pot to 95% of its CLOCKWISE rotation.

### IV. To check condition of local OSCILLATOR TUBE:

1. Turn unit ON and tune to a strong station in the upper frequencies of the bandwidth. (Above 104 MHZ).
2. Using a Variac, reduce the input voltage to 95 VAC.
3. If the station "drops out" then the local oscillator tube V3 is defective.

### V. To test for FRONT END SENSITIVITY: (IHFM)

1. With unit ON and tuned to a "dead spot", connect an FM generator to the antenna. (Be certain that the antenna input impedance is correctly matched). Turn the tuner muting switch OFF.
2. Match the generator frequency to that of the "dead spot" you have selected. Adjust modulation to 100% or 75 KHZ deviation. The output should then be adjusted to the minimum, typically 2 to 3 uv.

PAGE 3 of 5

# SERVICE BULLETIN

model number	bulletin number	date
10B	69-11/10B-1	
for serial numbers	to	
subject		

3. Connect a Harmonic Distortion Analyzer to the output of the tuner. Adjust the generator output and receiver tuner until you read 3% distortion on the distortion analyzer.
4. A sensitivity reading of 2 to 3 microvolts or less at 3% distortion is acceptable.

NOTE: Retouch front end calibration if necessary in order to obtain the best sensitivity possible.

PAGE 4 of 5

# SERVICE BULLETIN

model number 10B	bulletin number 8911710B-1	date
for serial numbers		to
subject		

## OSCILLOSCOPE ADJUSTMENT

NOTE: In making all adjustments, be certain that the external centering controls are properly set.

### I. INTENSITY:

1. Adjust the external horizontal and vertical controls normally.
2. Turn the display switch to EXTERNAL position and dim the panel switch.
3. Adjust the INTENSITY pot on the chassis to make the trace barely perceptible.

### II. VERTICAL

1. Tune the unit to the strongest station available.
2. Adjust the vertical pot on the main chassis until the trace appears approximately 1-1/2 bars from the top line.
3. When turning the internal vertical pot, always re-align the external controls to maintain the original centering.

- ### III,
1. Tune across the dial and adjust the horizontal pot on the main chassis until there is adequate horizontal displacement of the trace.
  2. As in the vertical adjustments, always re-align the external centering controls to maintain the original position.

PAGE 5 of 5

**marantz**

# SERVICE BULLETIN

SS-MAR0234

model number

10B

for serial numbers

ALL

subject

WARM UP TRANSIENTS

engineering approval

date

6/17/76

If you receive customer complaints regarding strong pop transients from the Marantz Model 10B during warm-up, the following modification is recommended.

At Stereo Switch RPL2, install two 470K ohm  $\frac{1}{4}$  W resistors (part number 434-6472) as shown below:

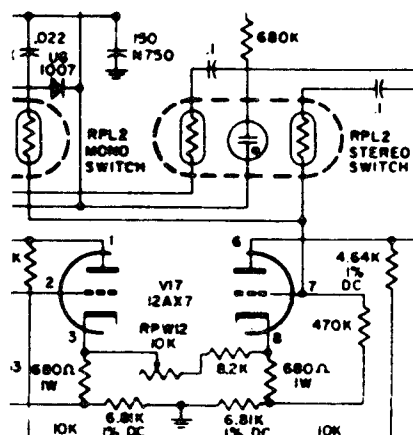

ORIGINAL

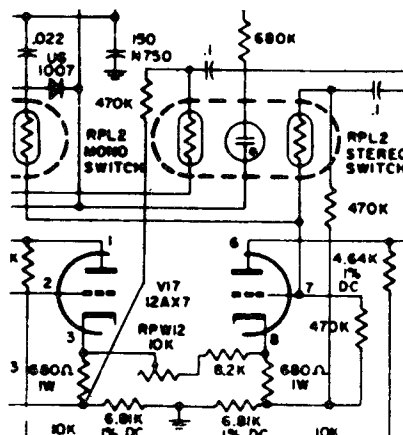

MODIFIED

If a click noise occurs when the stereo indicator lamp is activated, it is recommended a .03 uF 450 V capacitor be installed at V15 as shown below:

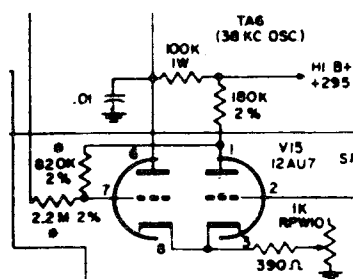

ORIGINAL

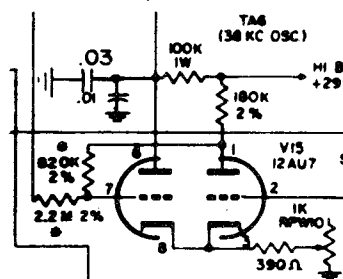

MODIFIED

*Albert Almeida*

Albert Almeida, Manager  
Technical Services

TUBE	TYPE	FUNCTION	CONDITIONS OF MEASUREMENT		PIN		PIN		PIN		PIN		REMARKS	
			PIN	VOLTS	PIN	VOLTS	PIN	VOLTS	PIN	VOLTS	PIN	VOLTS		
V22	DG7-32/01	SCOPE C.R.T.	DISPLAY SW. AT OUTPUT	1 VIO.	-260	2 VIO.	-250	3 YE.	-180	4 BR.	-140	6 GN	200	READINGS AT PIN (3) DEPEND ON INT. SET. AT PIN (4) DEPEND ON FOCUS SETTING.
			INT. AT MIN. FOCUS - NORMAL	7 BLUE	205	8 RED	200	9 BLUE	208	10 GN	208	12 GY	-260	
TRANSISTOR	2N3638	AMP. DISPLAY	DISPLAY SW. AT TUNING. NO SIGNAL	COL.	-1.33	EM.	-0.43	BASE	-1.03					
			DISPLAY SW. AT TUNING. 100% C.W. FROM REGENERATOR	COL.	-2.55	EM.	-0.14	BASE	-0.72					ALL READINGS DEPEND ON SIGNAL STRENGTH

NOTES:

Whenever measurements were taken with signal the set was tuned for 0 volt at V13A grid (pin 2)

- (1) Voltage between pins 2 and 7 is 1.1V
- (2) Varies with noise



TUBE	TYPE	FUNCTION	CONDITIONS OF MEASUREMENT	PLATE		GRID		CATHODE		SCREEN		
				PIN	VOLTS	PIN	VOLTS	PIN	VOLTS	PIN	VOLTS	
V17A	12AX7	AF AMP.		1	235	2	11	3	14.7			
V17B	12AX7	AF AMP.		6	235	7	10.7	8	14.2			
V18A	12AX7	OUTPUT CATH. FOLLOW.		1	280	2	0	3	2.4			
V18B	12AX7	OUTPUT CATH. FOLLOW.		6	280	7	0	8	2.4			
V19A	12AU7	MUTING SWITCHING	NO SIGNAL MUTTING OFF	1	290	2	-41	3	1.2			READINGS AT PINS (1) AND (3) DEPEND ON MUTING THRESHOLD SETTING
			NO SIGNAL MUTTING ON	1	45	2	4.1	3	4			
			200V. C.W. MUTTING ON	1	290	2	-51	3	1.3			
V19B	12AU7	MUTING SWITCHING	NO SIGNAL MUTTING OFF	6	40	7	0	8	1.2			READINGS AT PINS (6) (7) & (8) DEPEND ON MUTING THRESH. SETTING
			NO SIGNAL MUTTING ON	6	120	7	-2.6	8	4			
			100V C.W. MUTTING ON	6	25	7	0.95	8	1.3			
V20A	12AX7	SCOPE VERT. AMP.	DISPLAY SW. AT TUNING VERT. POS. GAIN - MAX. C.W.	1	205	2	-1.25	3	0.43			READINGS AT PINS (1) AND (3) DEPEND ON VERT. GAIN & POS. SETTING - AT PIN (2) ON VERT. C.
			DISPLAY SW. AT OUTPUT	1	205	2	0	3	1.6			
V20B	12AX7	SCOPE VERT. AMP.	DISPLAY SW. AT TUNING - VERT. GAIN POS. MAX. C.W.	6	200	7	-1.1	8	0.5			READINGS AT PINS (6) AND (8) DEPEND ON VERT. GAIN & POS. SETTING - AT PIN (7) ON VERT. POS.
			DISPLAY SW. AT OUTPUT	6	200	7	0	8	1.65			
V21A	12AX7	SCOPE HORIZ. AMP.	DISPLAY SW. AT TUNING. HORIZ. GAIN POS. MAX. C.W.	1	210	2	1.7	3	3.3			READINGS AT PINS (1) AND (3) DEPEND ON HOR. GAIN & POS. SETTING - AT PIN (2) ON HOR. G.
			DISPLAY SW. AT OUTPUT	1	208	2	0	3	1.6			
V21B	12AX7	SCOPE HORIZ. AMP.	DISPLAY SW. AT TUNING. HORIZ. GAIN POS. MAX. C.W.	6	205	7	1.85	8	3.3			READINGS AT PINS (6) AND (8) DEPEND ON HOR. GAIN & POS. SETTING - AT PIN (7) ON HOR. POS.
			DISPLAY SW. AT OUTPUT	6	208	7	0	8	1.6			

TUBE	TYPE	FUNCTION	CONDITIONS OF MEASUREMENT	PLATE		GRID		CATHODE		SCREEN		Observation
				PIN	VOLTS	PIN	VOLTS	PIN	VOLTS	PIN	VOLTS	
V13B	12AX7	CATHODE FOLLOWER		6	280	7	46	8	48			
V14A	6UB	COMPOSITE SIG. AMP.		6	134	2	22 <sup>(1)</sup>	7	47 <sup>(1)</sup>	3	124	
V14B	6UB	38 Kc AMP	NO SIGNAL	1	50	9	-0.5 <sup>(1)</sup>	8	0.7			READINGS AT PINS (1) AND (8) DEPEND ON STEREO THRESHOLD SETTING.
			C.W. SIGNAL FROM R.F. GEN. 100 μV (MONO)	1	37	9	0	8	0.72			«
			SET TUNED TO A STEREO STATION (KCBH)	1	74	9	-1.6	8	0.6			«
V15A	12AU7	STEREO SWITCHING	NO SIGNAL	9	60 <sup>(2)</sup>	2	-1.2 <sup>(2)</sup>	3	0.84			READINGS AT PINS (1) AND (2) DEPEND ON STEREO THRESHOLD SETTING.
			C.W. FROM R.F. GEN. OR MONO. W/TH MODE AT MONO	1	38	2	0	3	0.92			
			SET TUNED TO A STEREO STATION (KCBH)	1	153	2	-5	3	3.6			READINGS AT PINS (1) AND (2) DEPEND ON STEREO THRESHOLD SETTING.
V15B	12AU7	STEREO SWITCHING	NO SIGNAL	6	260	7	-30 <sup>(2)</sup>	8	0.84			READING AT PIN (7) DEPEND ON STEREO THRESHOLD SETTING.
			C.W. FROM R.F. GEN. OR MONO. W/TH MONO MODE	6	260	7	-43	8	0.92			
			SET TUNED TO A STEREO STATION (KCBH)	6	50	7	4	8	3.6			READINGS AT PINS (6) AND (7) DEPEND ON STEREO THRESHOLD SETTING.
V16A	12AU7	38 Kc OSCILL.	NO SIGNAL	1	134	2	-3.2 <sup>(2)</sup>	3	5.4			
			C.W. FROM R.F. GEN. 100 μV.	1	134	2	-2.5	3	5.4			
			SET TUNED TO A STEREO STATION (KCBH)	1	134	2	-3.4	3	5.4			
V16B	12AU7	38 Kc OSCILL.	NO SIGNAL	6	68	7	-0.3 <sup>(2)</sup>	8	5.4			READING AT PIN (7) VARIES TOO MUCH WITH NOISE
			C.W. FROM R.F. GEN. 100 μV.	6	58	7	3.8	8	5.4			
			SET TUNED TO A STEREO STATION (KCBH)	6	76	7	-8.0	8	5.4			

MODEL 10B CHECK OUT PROCEDURE

- 1) Check stereo and mono photo switches using heat gun.
- 2) Check pin 1 of all IF tubes (V4-V12) for a zero voltage indication. A grid voltage indicates a gassy tube. (REF. 10)
- 3) Make certain that output level pots are adjusted to maximum.
- 4) Rotate stereo threshold pot counterclockwise and check stereo indicator light. If light goes out than replace V13. OR V14
- 5) Leave stereo threshold pot 95% full on.
- 6) Adjust oscilloscope trace as follows:  
VERTICAL- Locate strongest station and adjust vertical pot so that trace will be  $1\frac{1}{2}$  bars from the top of graticle.  
HORIZONTAL- adjust horizontal pot for adequate displacement of trace when tuning.  
INTENSITY- Dim panel and put display switch on external position. Adjust intensity pot so that trace is barely perceptible.  
NOTE: All scope adjustments are made with external vert. and horiz. controls adjusted properly.
- 7) Test for front end sensitivity using FM generator and distortion analyzer. Sensitivity should be 4uv or less at 3% distortion.
- 8) Make channel separation test with FM generator set at 100MHZ. Separation should be approximately ~~30db~~ <sup>35db</sup> at 1KHZ.

*Lower input voltage to 95 VAC and make certain stereo light stays on. if FM DROPS OUT REPLACE LOCAL OSC.*

10-B DISTORTION .6 to .7 % OK.

## MARANTZ MODEL 10B

### DIAL GLASS REMOVAL AND CLEANING PROCEDURE

1. Remove tuning knob and switch knobs using a #8 Allen wrench.
2. Remove small scope centering knobs by pulling them off the shafts.
3. Remove satin chrome finished steel hood, secured to chassis with two screws, one at each side of hood.
4. Remove front panel, secured with two 1/2-inch hex nuts at the front and two 5/16-inch hex nuts at the top rear of the support brackets. Note, for reference during reassembly, the location of the spacer bushing and two lockwashers at each support bracket.
5. Detach the stereo indicator lamp bracket from the rear of the dial glass assembly frame by loosening one screw and sliding the lamp bracket out of the slot in the frame.
6. Prop up the front of the chassis, so that the front is raised a few inches higher than the rear.
7. Notice that there are four Phillips-head screws at each end of the dial glass assembly. Remove the top and bottom screws, only, at each end of the assembly.
8. Lift off dial glass assembly carefully to avoid damaging the red dial pointer.
9. Place the dial glass assembly face up on a flat clean surface and carefully remove the four remaining Phillips-head screws and the two clamp brackets.
10. Note, for reference during reassembly, the position of the rubber separator blocks between the two dial glasses.
11. Lift both dial glasses together and remove from the frame.
12. Carefully spread apart the two pieces of glass without tearing the black tape which holds them together at the top.
13. Clean both surfaces of each glass with a non-abrasive, non-waxy glass cleaner, such as Windex.
14. Reassemble the glasses, making sure that the rubber separator blocks are properly positioned.
15. Clean the inner surface of the black frame, then assemble the glasses to the frame, using the two clamp brackets and four screws. Tighten the four screws.

continued:

#### DIAL GLASS REMOVAL AND CLEANING PROCEDURE

16. Carefully place the dial glass assembly on the chassis, making certain that the red pointer is between the front and rear glasses. Install (without tightening) the 4 remaining Phillips-head screws.
17. Gently lift the dial glass assembly while turning the tuning shaft to verify that the pointer bracket (brass) does not scrape against the bottom edges of the glasses.
18. Tighten the four screws, then check that the pointer can be moved smoothly from one end of the dial to the other.
19. Slip the stereo indicator bracket onto the back of the dial glass frame and tighten the screw.
20. Reassemble the front panel to the chassis after cleaning it with a high-quality non-abrasive furniture polish.
21. Reassemble the steel hood to the chassis.
22. Install the knobs on all shafts..

## Dial Pointer Replacement-----

1. Proceed with steps 1, 2, and 3 of dial cord replacement.
2. Replace tuning knob and rotate counterclockwise to the limit.
3. Place pointer on cord.
4. Carefully replace dial glass assembly over pointer and temporarily install the 4 chrome-plated screws. Be certain the pointer is between the two glasses.
5. Gently lift glass assembly until pointer can move freely, then tighten 4 chrome-plated screws.
6. Check that tuning control is at counterclockwise stop; then center point over green calibration mark at left of dial scale.

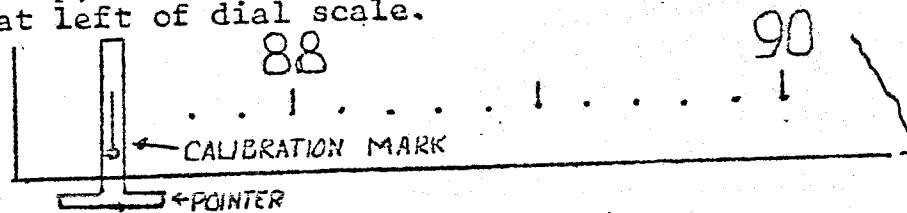

7. Rotate dial from left to right and back a few times, then check pointer position against calibration mark--- readjust if necessary.
8. Cement pointer in place with glyptol or equivalent adhesive.
9. Remove tuning knob and replace panel.
10. Check against known stations adjusting pointer position if necessary as outlined in "DIAL POINTER POSITIONING ADJUSTMENT" section in Owner's Manual.

Replacement of Dial Cord or Pointer Assembly of  
Marantz Model 10-B Stereo F.M. Tuner

Dial Cord Replacement-----

1. Remove all knobs--note scope adjustment knobs "slip on."
2. Remove stainless steel hood on back of panel and remove two nuts holding panel in place. **SAVE ALL LOCK WASHERS, SPACERS, ETC.!**
3. Remove black finish dial glass assembly by removing 4 chrome-plated screws. **DO NOT REMOVE BLACK SCREWS.**
4. Rotate dial drum to maximum clockwise position.

KEEP MODERATE TENSION ON  
DIAL CORD AT ALL TIME

A- ATTACH CORD TO DRUM WITH SMALL  
SPRING

B- ROUTE AROUND PULLEY

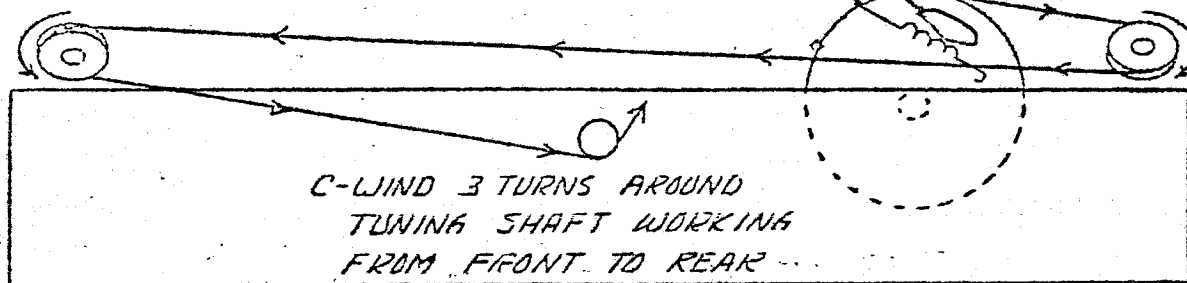

C- WIND 3 TURNS AROUND  
TUNING SHAFT WORKING  
FROM FRONT TO REAR

D- HOLD HERE AND WIND 1 TURN AROUND DRUM

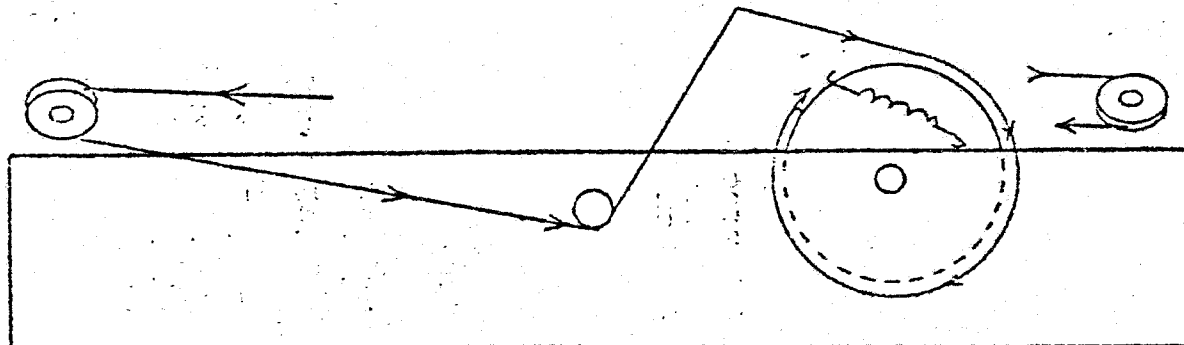

E- WIND ANOTHER FULL TURN-LOCATE IT BETWEEN  
THOSE ON THE DRUM

F- ROTATE DRUM  $\frac{3}{4}$  TURN TO THE LEFT AND ATTACH  
CORD TO DRUM WITH LONG SPRING

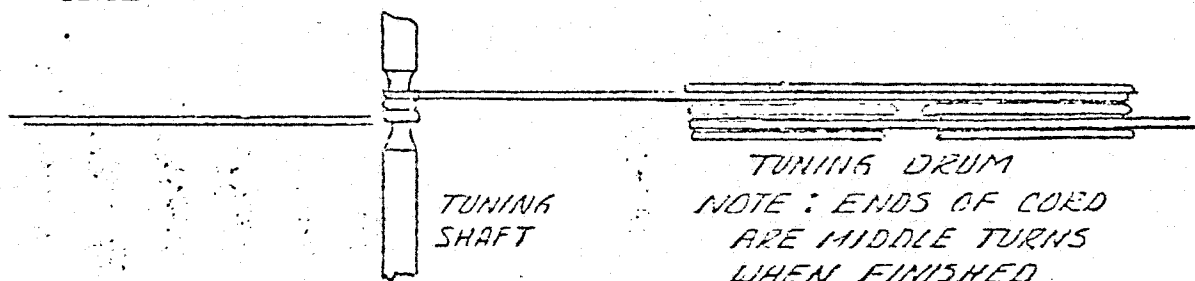

TUNING  
SHAFT

TUNING DRUM  
NOTE: ENDS OF CORD  
ARE MIDDLE TURNS  
WHEN FINISHED