

# marantz

model number 18	bulletin number 69-01/18-1	date
for serial numbers	to	
subject REPLACEMENT OF DIODES IN 12 VOLT SUPPLY		

For improved reliability and performance the two Zener Diodes (CR-10 & CR-11) are being replaced by a new type. These diodes are located behind the power transformer on the top main chassis. They provide regulation for the FM sections, scope display and tone amplifier. Their failure will result in a loss of FM operation, scope display or if the fault is in the plus side of the 12V supply (CR-10) it will cause a loss of output on both channels.

The older type, to be replaced, is identified by a blue band. Its leads will be dressed at right angles. the NEW TYPE is identified by a GREY band. This is illustrated below with a drawing showing the old and the preferred new installation.

The part number for the diodes remains the same: 35-1012

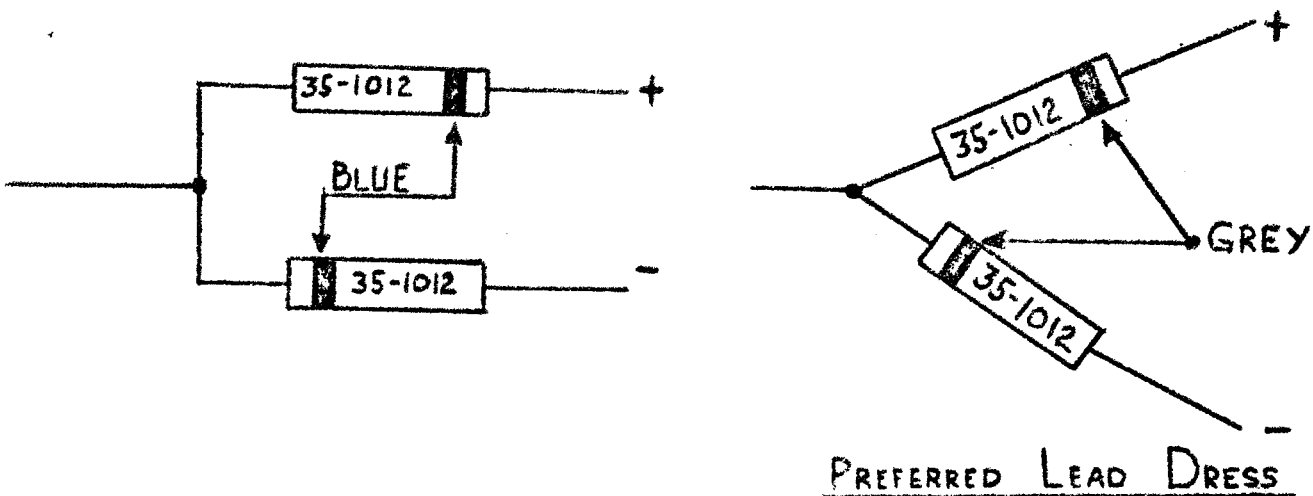

MR9-054a

**marantz**

model number 18	bulletin number 69-2/18-2	date
for serial numbers	to	
subject REPLACEMENT OF REFERENCE DIODES IN POWER AMPLIFIER.		

Reference diodes CR17 and CR18 are being replaced with a more reliable type. These diodes are located in the power amplifier section next to the bias pots R-26 and R-27. The old types are identified by the Marantz name printed on them and their small size compared to the replacement diodes.

After installing the NEW diodes, readjust the bias as follows:

1. Connect a VTVM across the 0.47 ohm, 5 watt resistor, R-28, (located near the power transistor, Q-11 at the left of the heat sink).
2. Adjust the bias pot, R-26 for a reading of 80 millivolts (0.08V).

Follow the same procedure for the right channel while taking the reading across R-43 and adjusting bias pot R-27.

Part numbers:

CR17	35-1002
CR18	35-1002

MR9-054

# marantz

model number 18	bulletin number 69-3/18-3	date
for serial numbers	to	
subject MODIFICATION OF STEREO PHOTOSWITCH		

The following circuit modification is designed to correct the intermittent stereo operation in the FM mode which results from improper operation of the STEREO PHOTOSWITCH, LDR602.

1. REMOVE the three wires between the terminals of the MPX MATRIX board and the MPX OSCILLATOR board (See FIG.1). Also remove one side of resistor R-25.
2. REMOVE the two screws which secure the MPX Matrix board to the main chassis. Carefully pull the board away to expose the foil side.
3. INSTALL two insulated wire JUMPERS across both sides of the STEREO PHOTOSWITCH, LDR602 as shown in FIG.2. This effectively bypasses its operation.
4. REPLACE the matrix board on the chassis and re-solder the wires and resistor removed in step one above.

NOTE: IF THE PREVIOUS WIRES WERE SOLID, REPLACE THEM WITH STRANDED WIRE FOR GREATER FLEXIBILITY.

**FIGURE I:**  
MR9-054d

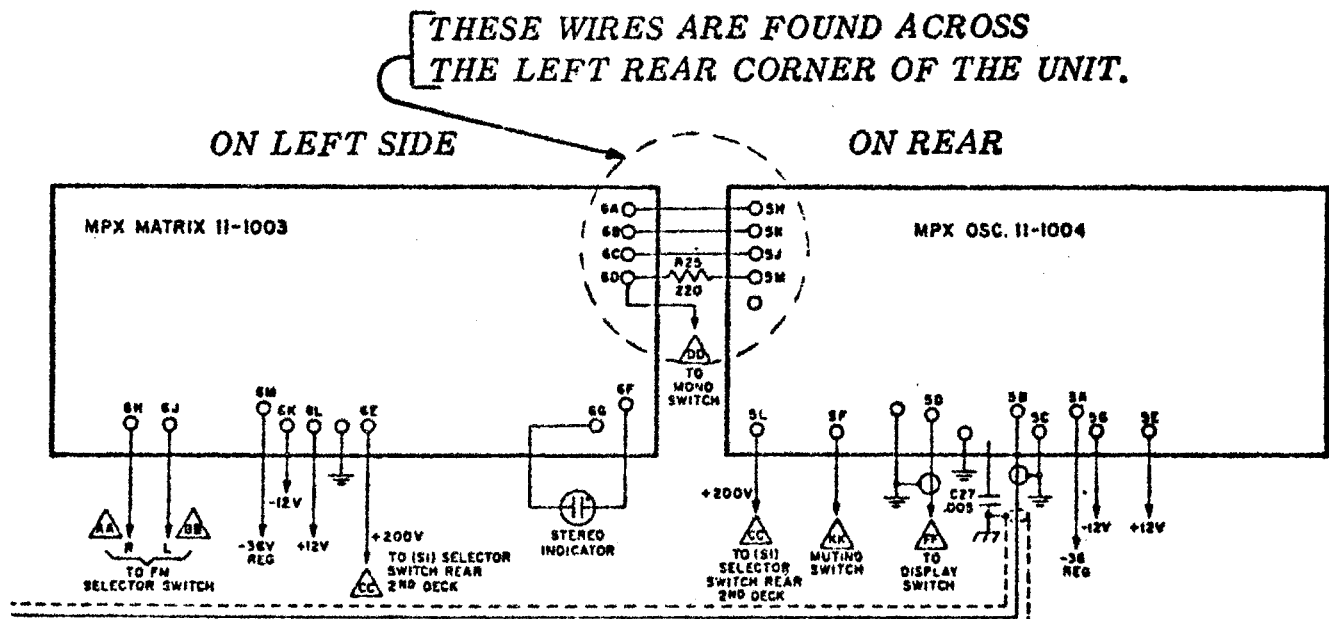

**marantz**

model number 18	bulletin number 69-4/18-4	date 7/7/69
for serial numbers	to	
subject  PROLONGING LIFE OF CRT		

Prolonged or excessive exposure of the display on the screen of the cathode ray tube will eventually cause the phosphor coating on the face of the 'scope to develop burned areas.

Since the burning of the CRT face is not covered under warranty, and for general extension of the CRT tube life, it is strongly recommended that when the trace is not actually being viewed it should be removed from the screen.

Remove the trace by rotating the vertical centering knob until the pattern is no longer visible on the screen.

MR9-054f

**marantz**

model number 18	bulletin number 69-5/18-5	date
for serial numbers	to	
subject SUB-CHASSIS CONNECTING PLUGS		

**OBSERVATIONS:** During shipment, the phono plugs which connect the FM front end, the antenna strip, the IF strip the limiter and the detector have been found to come loose. This causes a loss of FM operation. When unpacking each Model 18 Receiver, these phono plugs should be checked for continuity.

**CURE:** Apply a small spot of solder to each plug shield to hold it securely while still permitting its easy removal. This should be done to all phono jacks, including the IF and limiter plugs.

MR9-054b

**marantz**

model number 18	bulletin number 69-13/18-6	date 9-25-69
for serial numbers	to	
subject OBSERVATION OF OSCILLOSCOPE DRIFT		

The following procedure is to be used to determine whether the oscilloscope is operating within the acceptable limits of drift.

- 1) With the unit cold, turn the power ON. After the CRT warms up, press the TAPE MONITOR and AUDIO DISPLAY switches, then use the external HORIZONTAL and VERTICAL controls to position the dot into the center of the circle and on the line.
- 2) Allow the unit to remain on with these setting untouched for at least three hours.
- 3) After a minimum three-hour period, check the oscilloscope for drift by again pressing the TAPE MONITOR and AUDIO DISPLAY buttons and observing the position of the dot. If it appears to have moved from its original position by less than approximately 1/8 inch in any direction, then the oscilloscope is functioning properly.
- 4) If the oscilloscope drifts excessively in a horizontal direction then it will be necessary to replace transistors Q1205 and Q1206.
- 5) Excessive drift in a vertical direction requires the replacement of transistors Q1202 and Q1203.
- 6) Any excessive drift in a diagonal direction indicates that all the transistors mentioned above should be replaced.

**marantz**

model number 18	bulletin number 69-8/18-7	date
for serial numbers	to	
subject  RELOCATION OF PHONO INPUT GROUND WIRE		

Inspect the underside of the main chassis at the phono input jacks.

If the black phono ground wire runs inside the lip of the back panel near the AC cord and fuse holder, perform the following:

1. Cut the wire at the GND bus.
2. Dress the lead close to the main chassis, away from the AC cord.
3. Re-solder it to the GND bus bar.

MR9-054c

**marantz**

**SERVICE BULLETIN**

SS-MAR0234

model number 18	bulletin number M-18-8
for serial numbers ALL	
subject LIGHT CELL REPLACEMENT	
engineering approval <i>[Signature]</i>	date 11-25-75

The original LIGHT CELL ASSEMBLY, Ref. Desig. LDR501, Part Number 11-1010 is no longer available and has been replaced by Part Number 331-1005-000.

Prior to installation it is necessary to modify the replacement Light Cell Assembly and the Model 18 MPX Oscillator Board as described below;

Replacement  
LIGHT CELL ASSEMBLY, LDR501  
P/N 331-1005-000

Cut (2) Leads

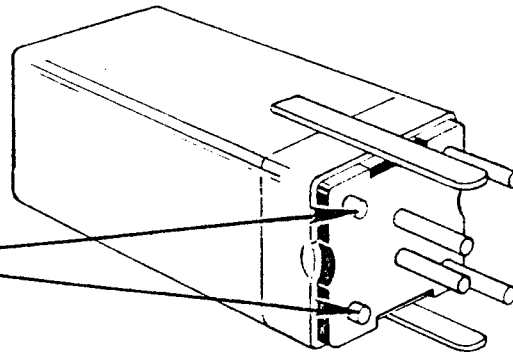

MODEL 18  
MPX Oscillator Board

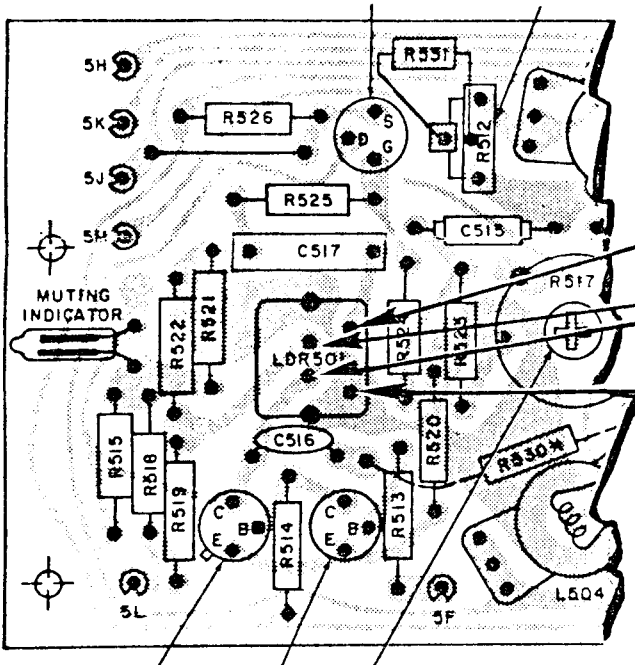

Enlarge PCB Holes  
[to accommodate larger  
lead diameter of replace-  
ment LDR501]

*[Signature]*  
Albert Almeida, Manager  
Technical Services

Marantz Part Number  
100-1012-001



ALIGNMENT OF MPX ON MARANTZ MODELS; 18,19,20,20B

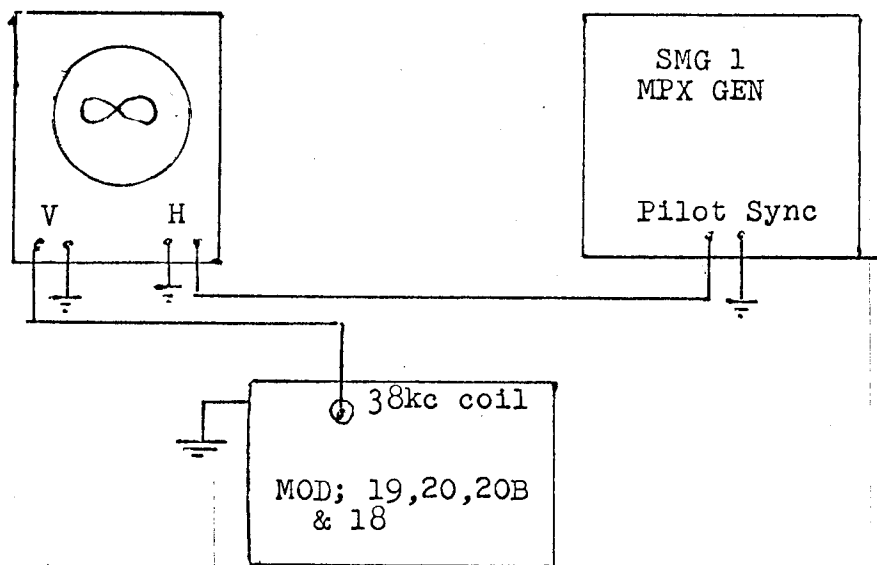

- A) Adjust det. for min. distortion
- B) Adjust 19kc and 38kc coil for max. symmetry of horizontal fig 8.
- C) Adjust sep. control for max stereo sep. L to R and R to L

POOR STEREO TRIGGERING  
MOD 22,23,24

Change R-564 from 100 ohms to 220 ohms to increase stereo threshold triggering.

note; Watch 15% meter range for drift on SMG-1 MPX gen.

## FIELD I.F. ALIGNMENT

### MODEL 18, 19, 20 & 20B

The following Field I.F. Alignment Procedure is intended for use only for emergencies and under conditions where return of the I.F. Assembly to the factory for alignment would be considered impossible. If, under normal conditions, it is felt that the I.F. requires realignment, return it to the factory.

**NOTE:** The regular Service Manual for the Model being serviced should be used along with this procedure.

#### A. Preliminary Setups

1. Construct an adaptor as shown in Figure 1.
2. Obtain an extra I.F. cover and modify per Figure 5.
3. Remove I.F. cover and install alignment cover (see Step 2 above).
4. Install adaptor (see Step 1) in the output jack of the I.F. and reconnect output cable to the adaptor. Also, connect a length of coax (with proper plugs) to the second jack of the adaptor. This will come into use later.

**NOTE:** It must be long enough and of the proper type to reach and connect to the vertical input of the Scope.

5. Make the test setup shown in Figure 2.  
**NOTE:** The Detector Output on the Model 18 is obtained by connecting between Pin #5B and Chassis Ground.
6. Disconnect the I.F. input from the Front End and connect a 10.7 MHz crystal oscillator to it.
7. Turn on set to be aligned and allow it and the test equipment to "warm up" for at least 30 minutes.

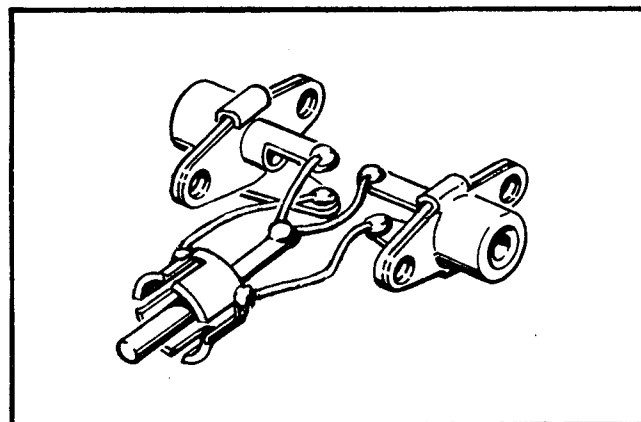

Figure 1. I.F. Output Adaptor

8. Set Scope Horizontal Input to D.C. and short the input. Adjust the position control until the trace is centered exactly.
9. Adjust V.T.V.M. for a "ZERO" reference point (with input shorted) at mid scale.
10. Remove input shorts on the equipment and turn on the 10.7 MHz oscillator.
11. The meter should read zero (0) volts and the scope trace should be centered horizontally. If not, adjust the Detector Secondary (C408-M18; C712-M19, 20 and 20B), for zero (0) volts.
12. Remove the 10.7 MHz oscillator and re-connect the Front End to the I.F. input.

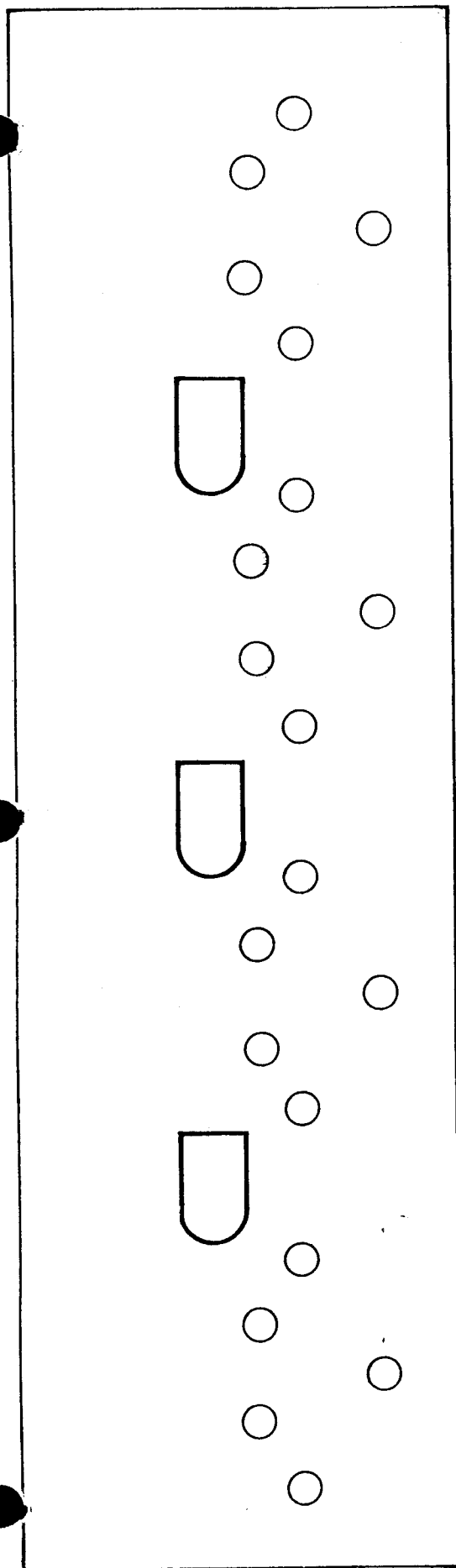

Figure 5. I.F. Alignment Cover Modification Template

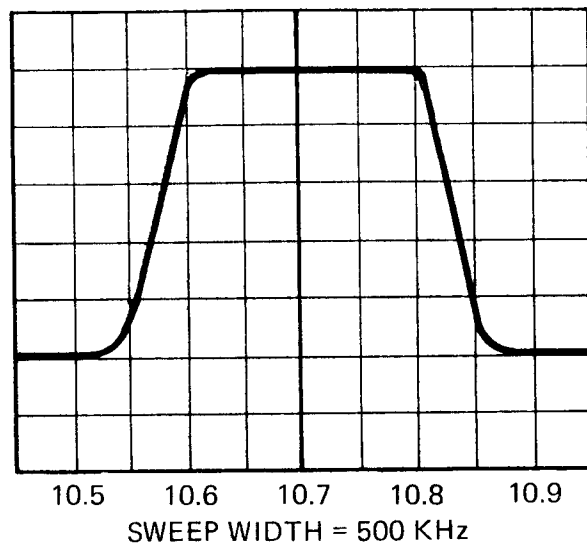

Figure 4. I.F. Bandpass Curve

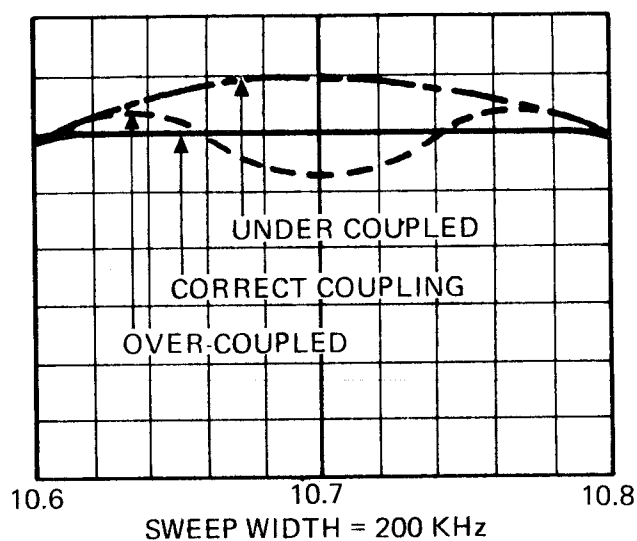

Figure 6. I.F. Bandpass Curve

Therefore, the response curve can not be any better than that of the first stage alone. Normally, the curve will degrade slightly (appearing more like the "under-coupled" curve) on the 200 KHz display as more stages come into play.

7. Move the scope probe to TP-3 (Ground clip to the shield between the third and fourth stage) and repeat Steps 3, 4 and 5 for the third stage.
8. Disconnect the scope probe from the scope input and replace it with the coax type cable from the output adaptor (see Section A - Step 4).
9. Repeat Steps 3, 4 and 5 for the fourth stage.
10. Remove all adaptors and connectors, etc., and restore receiver to operating condition.
11. Perform the Detector and MPX Alignments and check the receiver for overall performance.