

# DVP-S7700

RMT-D107A

## SERVICE MANUAL

US Model  
Canadian Model

**Self Diagnosis**  
Supported model



### SPECIFICATIONS

#### CD/DVD player

Laser Semiconductor laser  
Signal format system NTSC

#### Audio characteristics

Frequency response DVD (PCM96kHz): 2 Hz to 44 kHz ( $\pm 0.5$  dB)\*  
DVD (PCM48kHz): 2 Hz to 22 kHz ( $\pm 0.5$  dB)  
CD: 2 Hz to 20 kHz ( $\pm 0.5$  dB)  
Signal-to-noise ratio More than 115 dB (LINE OUT (AUDIO 1, 2) connectors only)  
Harmonic distortion Less than 0.0028%  
Dynamic range DVD: More than 100 dB  
CD: More than 97 dB  
Wow and flutter Less than detected value ( $\pm 0.001\%$  W PEAK)

#### Outputs and inputs

	Jack type	Output level	Load impedance
LINE OUT (AUDIO 1, 2)	Phono jacks	2 Vrms (at 50 kilohms)	Over 10 kilohms
DIGITAL OUT (OPTICAL)	Optical output connector	-18 dBm	Wave length: 660 nm
DIGITAL OUT (COAXIAL)	Phono jacks	0.5 Vp-p	75 ohms terminated
LINE OUT (VIDEO 1, 2)	Phono jack	1.0 Vp-p	75 ohms, sync negative
S VIDEO OUT 1, 2	4-pin mini DIN	Y: 1.0 Vp-p C: 0.286 Vp-p	75 ohms, sync negative 75 ohms terminated
COMPONENT VIDEO OUT (Y, Pb/B-Y, Pr/R-Y)	Phono jacks	Y: 1.0 Vp-p Pb/B-Y, Pr/R-Y: 0.7 Vp-p	75 ohms, sync negative 75 ohms
PHONES	Phone jack	12 mW	32 ohms
S-LINK	Minijack		

#### General

Power requirements 120 V AC, 60 Hz  
Power consumption 19 W  
Dimensions (approx.) 17 x 4 3/8 x 13 1/4 inches (430 x 111 x 335 mm) (w/h/d) incl. projecting parts  
Mass (approx.) 15 lb 7 oz (7.0 kg)  
Operating temperature 41 °F to 95 °F (5 °C to 35 °C)  
Operating humidity 5% to 90%

#### Supplied accessories

- Audio connecting cord (1)
- Video connecting cord (1)
- S-link connecting cord (1)
- S video cord (1)
- Remote commander (remote) RMT-D107A (1)
- Size AA (R6) batteries (2)

\* When you play the PCM sound tracks with 96 kHz sampling frequency, the output signals from the DIGITAL OUT (OPTICAL, COAXIAL) connectors are converted to 48 kHz (sampling frequency) / 16 bits (quantization bits).

Design and specifications are subject to change without notice.



CD/DVD PLAYER



# SONY®

## SAFETY CHECK-OUT

After correcting the original service problem, perform the following safety checks before releasing the set to the customer:

1. Check the area of your repair for unsoldered or poorly-soldered connections. Check the entire board surface for solder splashes and bridges.
2. Check the interboard wiring to ensure that no wires are "pinched" or contact high-wattage resistors.
3. Look for unauthorized replacement parts, particularly transistors, that were installed during a previous repair. Point them out to the customer and recommend their replacement.
4. Look for parts which, though functioning, show obvious signs of deterioration. Point them out to the customer and recommend their replacement.
5. Check the B+ voltage to see it is at the values specified.
6. Check the B+ voltage to see it is at the values specified.
7. Check the antenna terminals, metal trim, "metallized" knobs, screws, and all other exposed metal parts for AC leakage. Check leakage as described below.

### LEAKAGE TEST

The AC leakage from any exposed metal part to earth ground and from all exposed metal parts to any exposed metal part having a return to chassis, must not exceed 0.5 mA (500 microamperes). Leakage current can be measured by any one of three methods.

1. A commercial leakage tester, such as the Simpson 229 or RCA WT-540A. Follow the manufacturers' instructions to use these instruments.
2. A battery-operated AC milliammeter. The Data Precision 245 digital multimeter is suitable for this job.
3. Measuring the voltage drop across a resistor by means of a VOM or battery-operated AC voltmeter. The "limit" indication is 0.75V, so analog meters must have an accurate low-voltage scale. The Simpson 250 and Sanwa SH-63Trd are examples of a passive VOM that is suitable. Nearly all battery operated digital multimeters that have a 2V AC range are suitable. (See Fig. A)

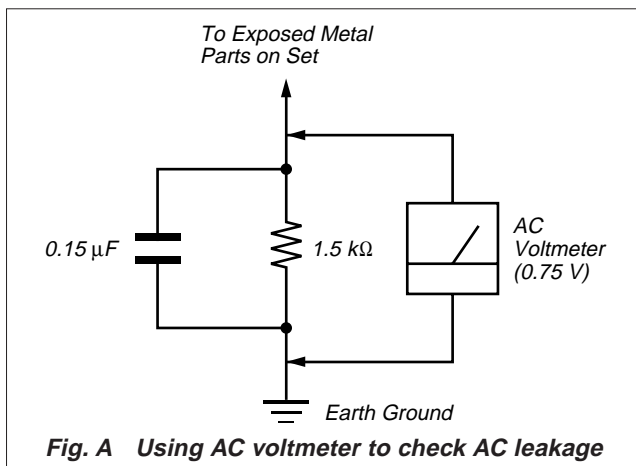


Fig. A Using AC voltmeter to check AC leakage

### WARNING!!

WHEN SERVICING, DO NOT APPROACH THE LASER EXIT WITH THE EYE TOO CLOSELY. IN CASE IT IS NECESSARY TO CONFIRM LASER BEAM EMISSION, BE SURE TO OBSERVE FROM A DISTANCE OF MORE THAN 25 cm FROM THE SURFACE OF THE OBJECTIVE LENS ON THE OPTICAL PICK-UP BLOCK.

### CAUTION:

The use of optical instrument with this product will increase eye hazard.

### CAUTION

Use of controls or adjustments or performance of procedures other than those specified herein may result in hazardous radiation exposure.

### SAFETY-RELATED COMPONENT WARNING!!

COMPONENTS IDENTIFIED BY MARK  $\triangle$  OR DOTTED LINE WITH MARK  $\triangle$  ON THE SCHEMATIC DIAGRAMS AND IN THE PARTS LIST ARE CRITICAL TO SAFE OPERATION. REPLACE THESE COMPONENTS WITH SONY PARTS WHOSE PART NUMBERS APPEAR AS SHOWN IN THIS MANUAL OR IN SUPPLEMENTS PUBLISHED BY SONY.

### ATTENTION AU COMPOSANT AYANT RAPPORT À LA SÉCURITÉ!

LES COMPOSANTS IDENTIFIÉS PAR UNE MARQUE  $\triangle$  SUR LES DIAGRAMMES SCHÉMATIQUES ET LA LISTE DES PIÈCES SONT CRITIQUES POUR LA SÉCURITÉ DE FONCTIONNEMENT. NE REMPLACER CES COMPOSANTS QUE PAR DES PIÈCES SONY DONT LES NUMÉROS SONT DONNÉS DANS CE MANUEL OU DANS LES SUPPLÉMENTS PUBLIÉS PAR SONY.

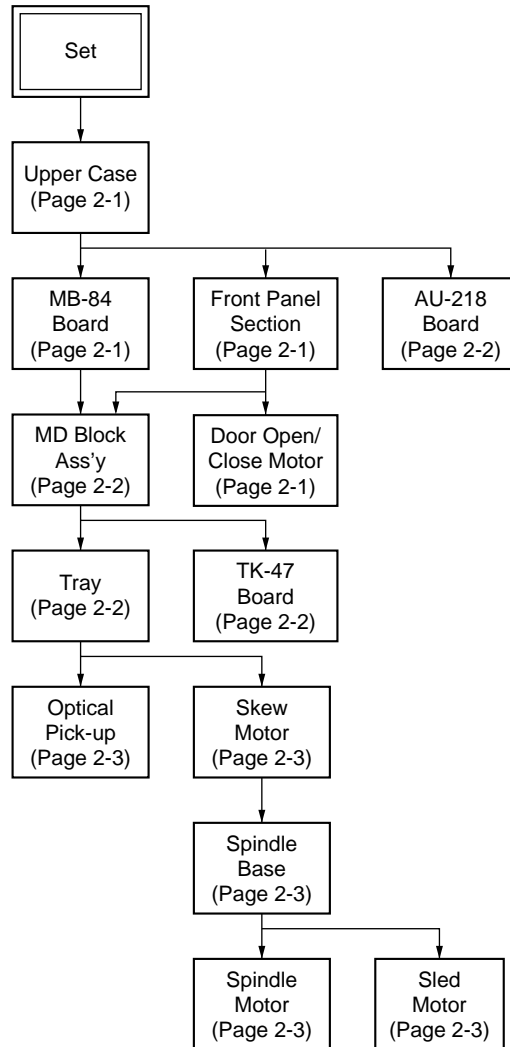
## TABLE OF CONTENTS

<u>Section</u>	<u>Title</u>	<u>Page</u>	<u>Section</u>	<u>Title</u>	<u>Page</u>
Service Note .....		4			
<b>1. GENERAL</b>					
	This Player Can Play the Following Discs .....	1-1		CN-112, DR-87, FL-107, FR-159, PW-119 Printed Wiring Boards .....	4-63
	Getting Started .....	1-1		CN-112, DR-87, FL-107, FR-159, PW-119 Schematic Diagrams .....	4-65
	Basic Operations .....	1-2		PS-420 Printed Wiring Board .....	4-67
	Playing Discs in Various Modes .....	1-4		PS-420 Schematic Diagram .....	4-69
	Setting and Adjustments .....	1-8		POWER BLOCK (HS-930SU) Printed Wiring Board ....	4-72
	Additional Information .....	1-9		POWER BLOCK (HS-930SU) Schematic Diagram .....	4-73
<b>2. DISASSEMBLY</b>			<b>5. IC PIN FUNCTION DESCRIPTION</b>		
2-1. Upper Case Removal .....	2-1		5-1. Interface Control Pin Function (MB-84 Board IC604) ..	5-1	
2-2. Front Panel Removal .....	2-1		5-2. System Control Pin Function (MB-84 Board IC805) ....	5-2	
2-3. Door Open/Close Motor Removal .....	2-1		<b>6. TEST MODE</b>		
2-4. MB-84 Board Removal .....	2-1		6-1. Starting up Test Mode .....	6-1	
2-5. AU-218 Board Removal .....	2-2		6-2. Selection of Check Item .....	6-1	
2-6. MD Block Ass'y Removal .....	2-2		6-2-1. Selected Item Check .....	6-1	
2-7. TK-47 Board Removal .....	2-2		6-2-2. All Items Check .....	6-1	
2-8. Tray Removal .....	2-2		6-3. Error Display .....	6-2	
2-9. Skew Motor (M903) Removal .....	2-3		6-4. General Description of Checking Method .....	6-2	
2-10. Sled Motor (M501) Removal .....	2-3		6-5. Drive Auto Adjustment .....	6-8	
2-11. Spindle Motor (M901) Removal .....	2-3		6-6. Drive Manual Operation .....	6-12	
2-12. Optical Pick-up Removal .....	2-3		6-6-1. Drive Manual Operation Menu Screen .....	6-12	
2-13. Internal Views .....	2-4		6-6-2. Disc Type .....	6-12	
2-14. Circuit Boards Location .....	2-5		6-6-3. Manual Control 1 .....	6-12	
<b>3. BLOCK DIAGRAMS</b>			6-6-4. Manual Control 2 .....	6-13	
3-1. Overall Block Diagram .....	3-1		6-6-5. Manual Control 3 .....	6-13	
3-2. RF/Servo Block Diagram .....	3-3		6-6-6. Manual Adjust 1 .....	6-13	
3-3. Signal Process Block Diagram .....	3-5		6-6-7. Manual Adjust 2 .....	6-14	
3-4. Video Block Diagram .....	3-7		6-6-8. Auto Adjust .....	6-14	
3-5. System Control Block Diagram .....	3-9		6-6-9. Check .....	6-14	
3-6. Audio Block Diagram .....	3-11		6-6-10. EEPROM Data Screen Display .....	6-15	
3-7. Mode Control Block Diagram .....	3-13		6-7. Other Operation .....	6-15	
3-8. Power Block Diagram .....	3-15		6-8. Emergency History .....	6-16	
<b>4. PRINTED WIRING BOARDS AND SCHEMATIC DIAGRAMS</b>			6-9. Error Code .....	6-18	
4-1. Frame Schematic Diagram .....	4-3		<b>7. ELECTRICAL ADJUSTMENT</b>		
4-2. Printed Wiring Boards and Schematic Diagrams .....	4-7		7-1. Power Supply Check .....	7-1	
TK-47 Printed Wiring Board .....	4-7		1. HS-930SU Board .....	7-1	
TK-47 (RF, Servo 1) Schematic Diagram .....	4-11		7-2. Adjustment of System Control .....	7-2	
TK-47 (RF, Servo 2) Schematic Diagram .....	4-13		1. System Clock 27 MHz Adjustment .....	7-2	
MB-84, FG-43 Printed Wiring Boards .....	4-15		7-3. Adjustment of Video System .....	7-2	
MB-84 (AV Decoder) Schematic Diagram .....	4-19		1. Video Level Adjustment .....	7-2	
MB-84 (Clock Generator) Schematic Diagram .....	4-21		2. S-terminal Output Check .....	7-2	
MB-84 (DNR) Schematic Diagram .....	4-23		3. Checking Component Video Output B-Y .....	7-2	
MB-84 (Video Encoder) Schematic Diagram .....	4-25		4. Checking Component Video Output R-Y .....	7-3	
MB-84 (Drive 1) Schematic Diagram .....	4-27		5. Checking Component Video Output Y .....	7-3	
MB-84 (Drive 2), FG-43 Schematic Diagrams .....	4-29		6. Checking S Video Output S-C .....	7-3	
MB-84 (DSP 1) Schematic Diagram .....	4-31		7. Checking S Video Output DC Level .....	7-3	
MB-84 (DSP 2) Schematic Diagram .....	4-33		7-4. Adjustment Related Parts Arrangement .....	7-4	
MB-84 (Bias) Schematic Diagram .....	4-35		<b>8. REPAIR PARTS LIST</b>		
MB-84 (IF $\mu$ -com) Schematic Diagram .....	4-37		8-1. Exploded Views .....	8-1	
MB-84 (L Gate Array) Schematic Diagram .....	4-39		8-1-1. Case Assembly .....	8-1	
MB-84 (ARP, Decrypt) Schematic Diagram .....	4-41		8-1-2. Front Panel Assembly .....	8-2	
MB-84 (System $\mu$ -com) Schematic Diagram .....	4-43		8-1-3. Chassis Assembly .....	8-3	
MB-84 (S Gate Array) Schematic Diagram .....	4-45		8-1-4. DVD Mechanism Chassis Assembly (1) .....	8-4	
AU-218 Printed Wiring Board .....	4-47		8-1-5. DVD Mechanism Chassis Assembly (2) .....	8-5	
AU-218 (Audio 1) Schematic Diagram .....	4-51		8-2. Electrical Parts List .....	8-6	
AU-218 (Audio 2) Schematic Diagram .....	4-53				
AU-218 (Video Buffer) Schematic Diagram .....	4-55				
YS-18 Printed Wiring Board and Schematic Diagram .....	4-57				
FP-60 , HP-119 Printed Wiring Boards .....	4-59				
FP-60 , HP-119 Schematic Diagrams .....	4-61				

# SERVICE NOTE

## 1. DISASSEMBLY

- This set can be disassembled in the order shown below.



## 2. DISK REMOVAL PROCEDURE (at POWER OFF)

### 2-1. How to Open the Door

- 1) With the top case removed, rotate the gear (D) ① in direction ① to open the door. (See Fig. 1)

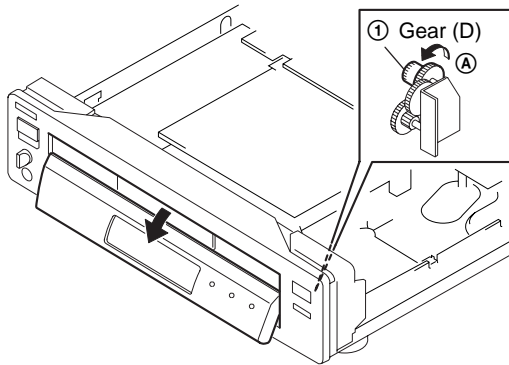


Fig. 1

### 2-2. How to Draw out Tray

- 1) Insert a cross-tip screwdriver into a hole at the bottom, and rotate the cam gear ② in direction ②. (See Fig. 2)  
**Note:** To prevent a damage of cam gear, rotate it in direction ② by 1/4 turn.
- 2) Draw out the tray ③ in direction ③ by hand, and remove a disk. (See Fig. 2)

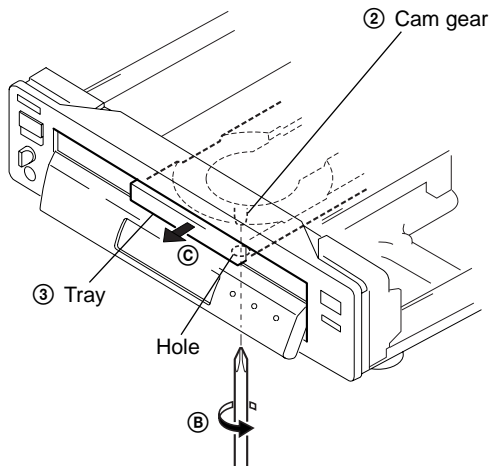


Fig. 2

## 3. HOW TO SERVICE MB-84 (SIDE B) BOARD

- 1) Remove the case from the set. (Refer to 2-1)
- 2) Remove the cover (upper). (Refer to 2-3)
- 3) Set the MB-84 board as shown in Fig. 3.

**Note 1:** Do not disconnect wiring.

**Note 2:** Spread a insulating material under the MB-84 board and through down lest you should short.

- 4) Mount the extension cable (J-6090-079-A).  
(MB-84 (CN601) ↔ FL-107 (CN153))

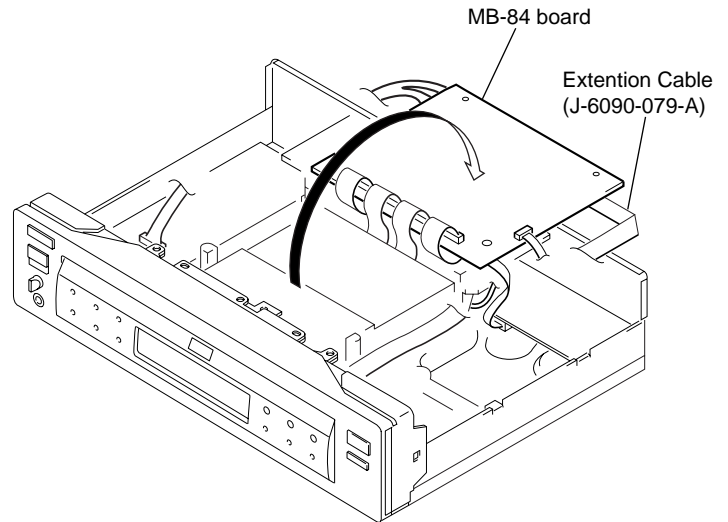
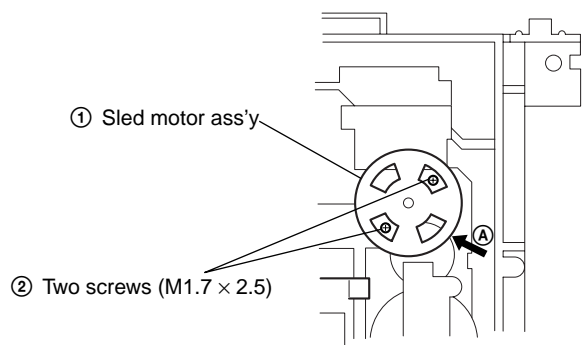


Fig. 3

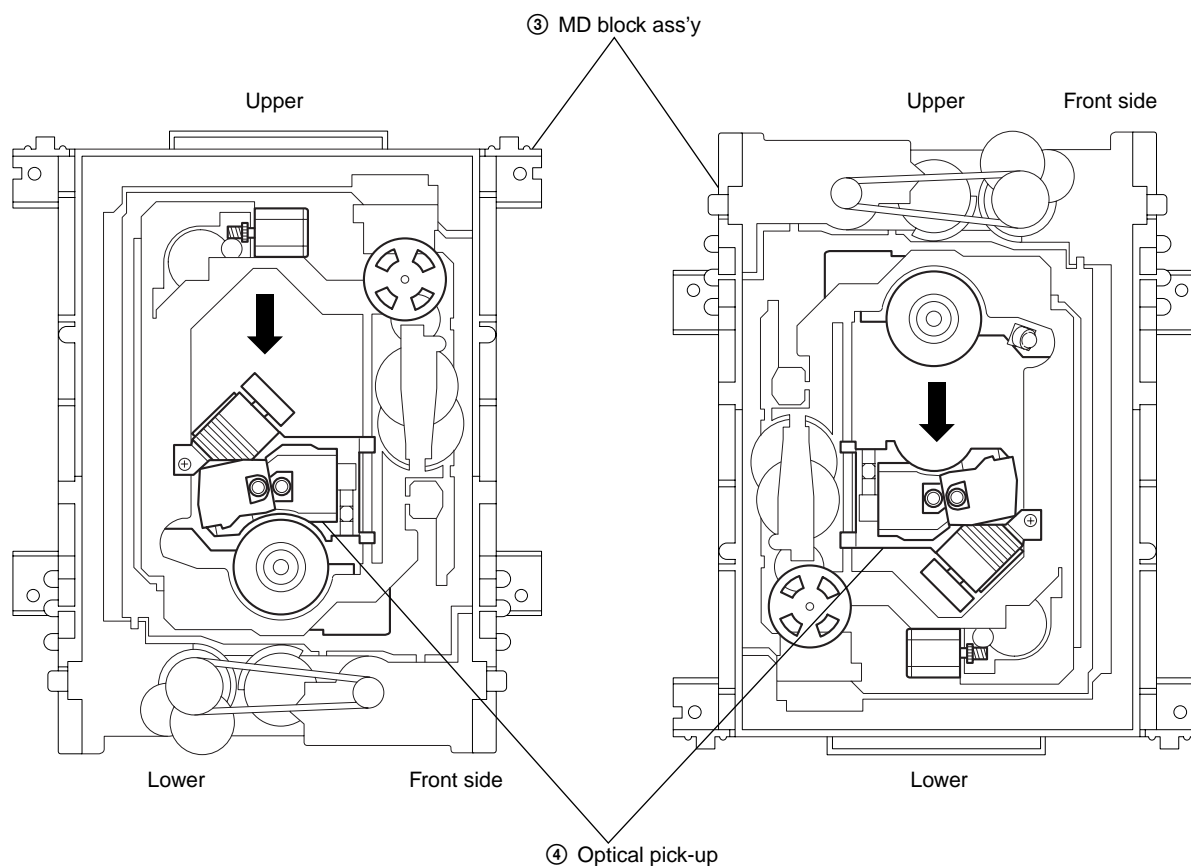
#### 4. NOTE ON MOUNTING SLED MOTOR

- 1) Push the sled motor ass'y ① toward direction ①A. (See Fig. 4)
- 2) Tighten two screws ② (M1.7 × 2.5).



**Fig. 4**

- 3) Raising the MD block ass'y ③ 90° with the side down, confirm that the optical pick-up ④ falls by self weight. (See Fig. 5)
- 4) Further, with the front side of MD block ass'y ③ up, confirm that the optical pick-up falls by self weight.

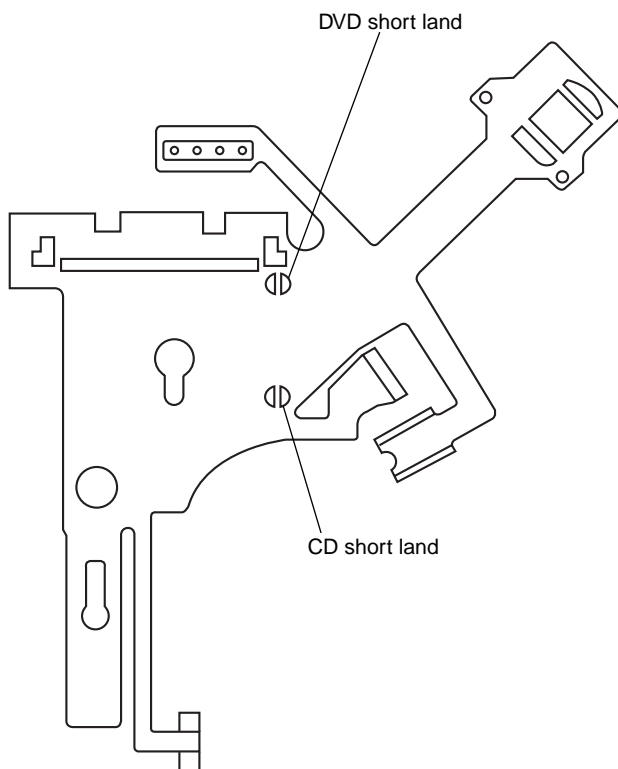


**Fig. 5**

## 5. REPLACING OPTICAL PICK-UP

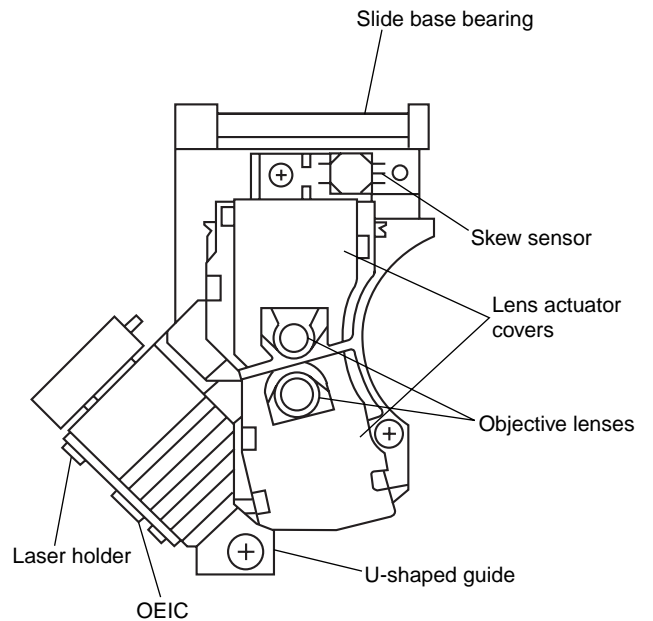
### 5-1. Handling

- 1) A red laser diode for DVD requires more attention to static electricity than general infrared laser diodes for CD. Because its durability to static electricity is far weaker than that of infrared laser diodes, always use an earth band when handling the optical pick-up block as service parts.
- 2) As for the flexible board KHS-180A (RP) packed as service parts, the short lands have been soldered to protect from static electricity. Accordingly, remove solders when replacing optical pick-up. (See Fig. 6)

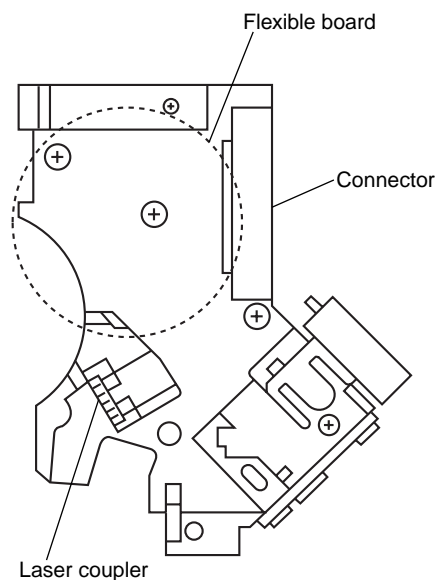


**Fig. 6 Flexible board**

- 3) In handling the KHS-180A (RP), do not touch inhibited parts shown in Fig. 7, but grip the slide base bearing and U-shaped guide.



- Touch inhibited parts
- Objective lens
  - Skew sensor
  - Laser holder
  - Laser coupler
  - Flexible board
  - OEIC
  - Lens actuator covers



**Fig. 7 KHS-180A (RP)**

## 6. NOTE ON ASSEMBLING MECHANICAL DECK

### 6-1. Application of Grease

- 1) Grease must be applied if the following parts were replaced.  
(See Fig. 8)

**Note 1:** Recommended grease is Foil KG-70MP.

**Note 2:** In applying grease, take care not to allow grease to stick to other parts (particularly, rubber belt, spindle motor, and optical pick-up)

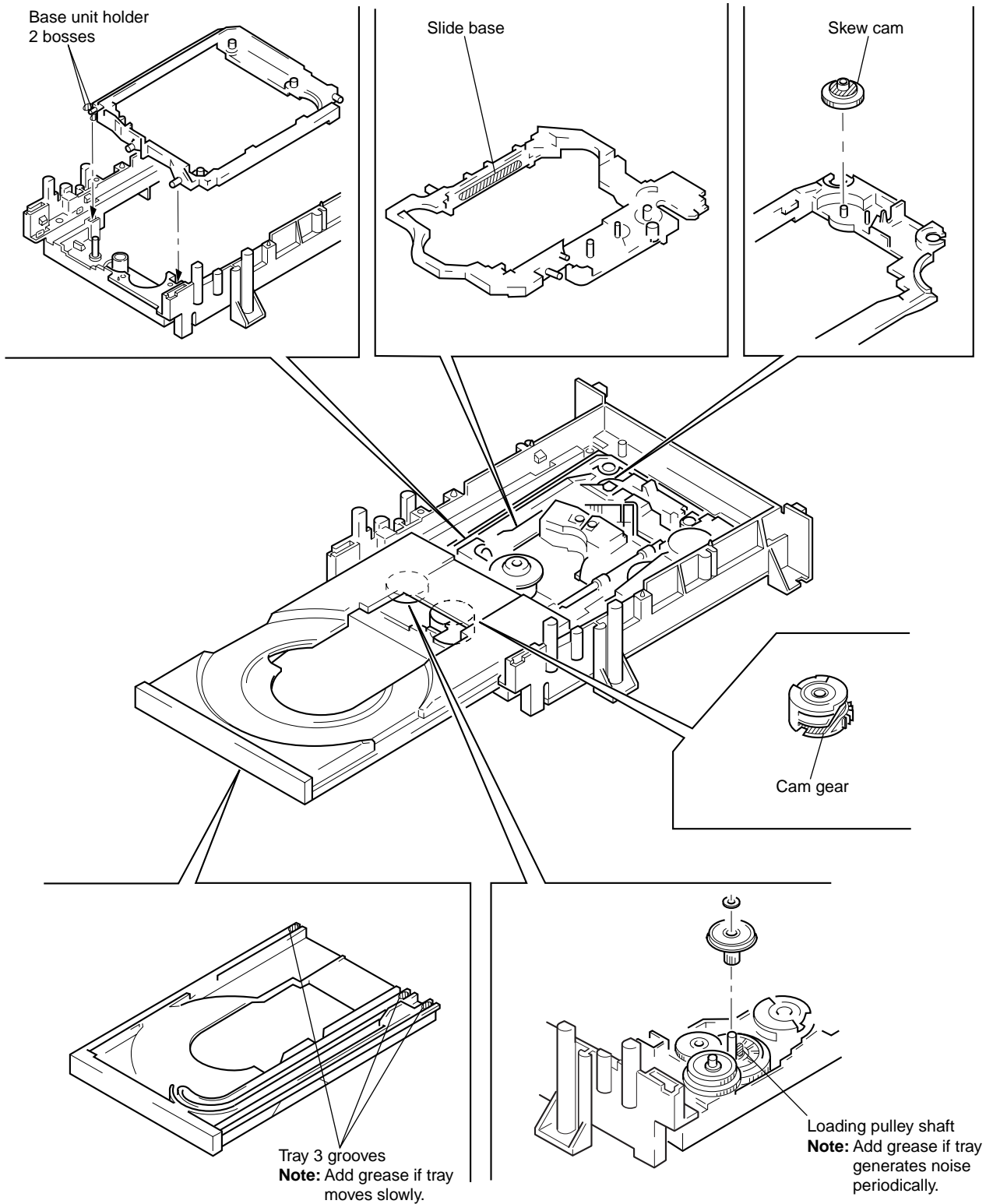


Fig. 8



### 6-2. Cleaning Spindle Motor Turntable

- 1) Remove the tray. (Refer to 2-7)
- 2) Clean the spindle motor turntable if disc antiskid rubber (black) is dirty. (See Fig. 9)

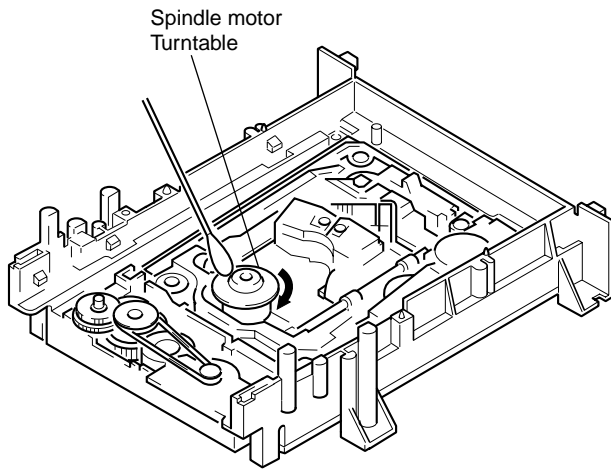


Fig. 9

### 6-3. Aligning Phase of Cam Gear and Drive Gear

- 1) Align triangle marks when assembling the cam gear and drive gear. (See Fig. 10)

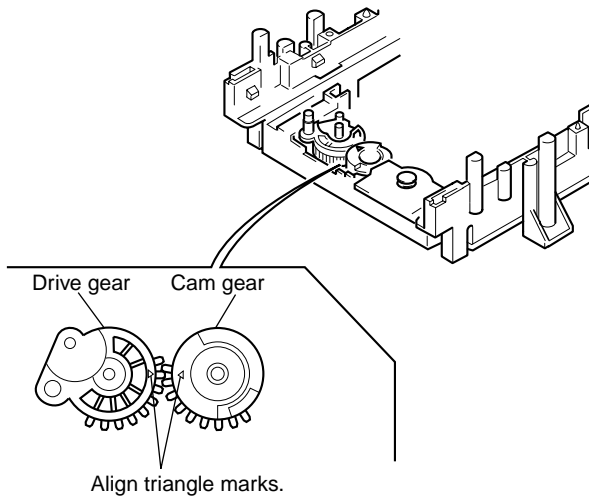


Fig. 10

### 6-4. Deformation of Insulator

- 1) Assemble the spindle base into the base unit.
- 2) Lock with 4 shoulder screws. (See Fig. 11)
- 3) Check if 4 insulators deformed. (See Fig. 11)

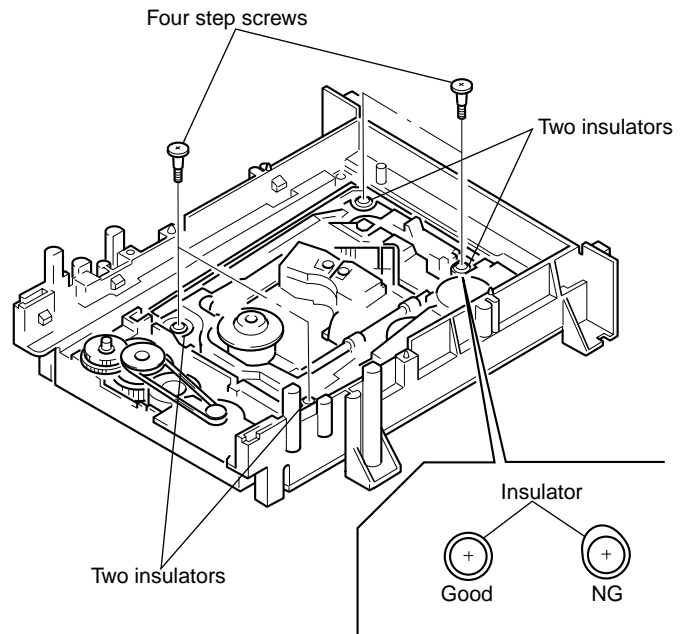


Fig. 11

### 6-5. Note on Mounting FG-43 Board

- 1) Align two bosses. (See Fig. 12)
- 2) Fix the board securely with screws (PTPWH2 × 5). (The sensor will not function normally if the board floats up.)

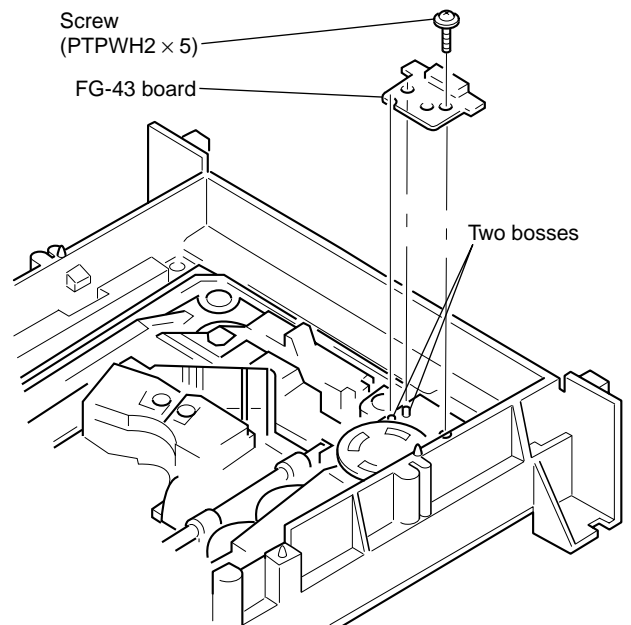


Fig. 12

### 6-6. Note on Mounting TK-47 Board

- 1) Align two bosses. (See Fig. 13)
- 2) Align four tabs. (See Fig. 13)
- 3) Fix the board securely with 3 screws (BV3 × 10). (The sensor will not function normally if the board floats up.)

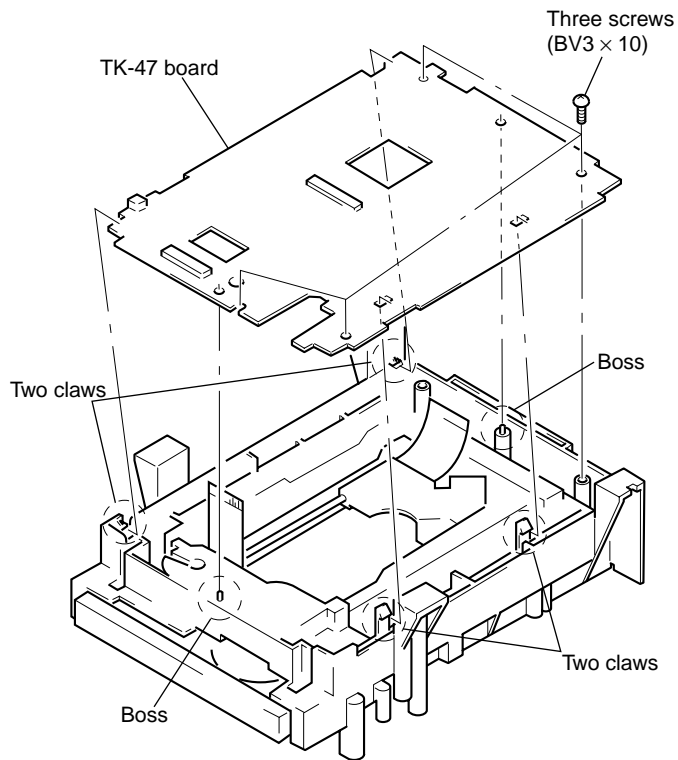


Fig. 13

### 6-7. Note on connecting OPT Harness

- 1) The optical pick-up could be destroyed unless the OPT harness is connected normally to the connector. (See Fig. 14)

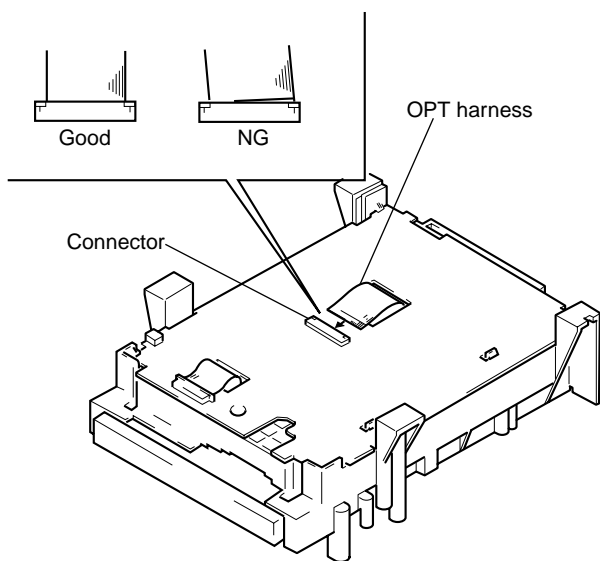


Fig. 14

# SECTION 1 GENERAL

This section is extracted from instruction manual.

## About This Manual

The instructions in this manual are for model DVP-S7700.

### Conventions

- Instructions in this manual describe the controls on the player.
- You can also use the controls on the remote if they have the same or similar names as those on the player.
- The icons on the right are used in this manual:

Icon	Meaning
	Indicates that you can use only the remote to do the task.
	Indicates tips and hints for making the task easier.
	Indicates the functions for DVD VIDEOS.
	Indicates the functions for VIDEO CDs.
	Indicates the functions for Audio CDs.

## This Player Can Play the Following Discs

Disc logo	DVD VIDEOS		VIDEO CDs		Audio CDs	
Contents	Audio + Video		Audio + Video		Audio	
Disc size	12 cm	8 cm	12 cm	8 cm	12 cm	8 cm (CD single)
Play time	About 4 h (for single-sided DVD)/ about 8 h (for double-sided DVD)	About 80 min. (for single-sided DVD)/ about 160 min. (for double-sided DVD)	74 min.	20 min.	74 min.	20 min.

\*"DVD VIDEO" logo is a trademark.

This player conforms to the NTSC color system. You cannot play discs recorded in other color systems such as PAL or SECAM.

### Region code of DVDs you can play on this unit

Your DVD player has a region code printed on the back of the unit and will only play DVDs that are labeled with identical region codes.

DVDs labeled will also play on this unit.

If you try to play any other DVD, the message "Playing this disc prohibited by area limits." will appear on the TV screen.

Depending on the DVD, no region code indication may be labeled even though playing the DVD is prohibited by the area limits.

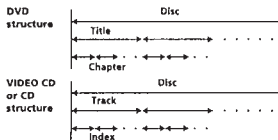


### Note on playback operations of DVDs and VIDEO CDs

Some playback operations of DVDs and VIDEO CDs may be intentionally fixed by software producers. Since this player plays DVDs and VIDEO CDs according to the disc contents the software producers designed, some playback features may not be available. Also refer to the instructions supplied with the DVDs or VIDEO CDs.

### Terms for discs

- **Title**  
The longest sections of a picture or a music piece on a DVD; a movie, etc. for a picture piece on a video software; or an album, etc. for a music piece on an audio software. Each title is assigned a title number enabling you to locate the title you want.
- **Chapter**  
Sections of a picture or a music piece that are smaller than titles. A title is composed of several chapters. Each chapter is assigned a chapter number enabling you to locate the chapter you want. Depending on the disc, no chapters may be recorded.
- **Track**  
Sections of a picture or a music piece on a VIDEO CD or a CD. Each track is assigned a track number enabling you to locate the track you want.



### • Index (CD) / Video Index (VIDEO CD)

A number that divides a track some sections to easily locate the point you want on a VIDEO CD or a CD. Depending on the disc, no indexes may be recorded.

### • Scene

On a VIDEO CD with PBC functions, the menu screens, moving pictures and still pictures are divided into sections called "scenes." Each scene is assigned a scene number enabling you to locate the scene you want.

### Note on PBC (Playback Control) (VIDEO CDs)

This player conforms to Ver. 1.1 and Ver. 2.0 of VIDEO CD standards. You can enjoy two kinds of playback according to the disc type.

Disc type	You can
VIDEO CDs without PBC functions (Ver. 1.1 discs)	Enjoy video playback (moving pictures) as well as music.
VIDEO CDs with PBC functions (Ver. 2.0 discs)	Play interactive software using menu screens displayed on the TV screen (PBC Playback), in addition to the video playback functions of Ver 1.1 discs. Moreover, you can play high-resolution still pictures, if they are included on the disc.

### Discs that the player cannot play

The player cannot play discs other than the ones listed in the table on page 4. CD-ROMs including PHOTO CDs, data sections in CD-EXTRAS and DVD-ROMs, etc. can not be played.

When playing DTS-encoded CDs, excessive noise will be exhibited from the analog stereo outputs. To avoid possible damage to the audio system, the consumer should take proper precautions when the analog stereo outputs of the DVD player is connected to an amplification system. To enjoy DTS Digital Surround™ playback, an external 5.1 channel DTS Digital Surround™ decoder system must be connected to the digital output of the DVD player.

This product incorporates copyright protection technology that is protected by method claims of certain U.S. patents and other intellectual property rights owned by Macrovision Corporation and other rights owners. Use of this copyright protection technology must be authorized by Macrovision Corporation, and is intended for home and other limited viewing uses only unless otherwise authorized by Macrovision Corporation. Reverse engineering or disassembly is prohibited.

## Getting Started

## Getting Started

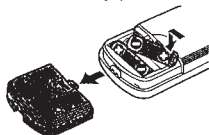
### Unpacking

Check that you have the following items:

- Audio connecting cord (1)
- Video connecting cord (1)
- S-link connecting cord (1)
- S video cord (1)
- Remote commander (remote) RMT-D107A (1)
- Size AA (R6) batteries (2)

### Inserting batteries into the remote

You can control the player using the supplied remote. Insert two R6 (size AA) batteries by matching the + and - on the batteries. When using the remote, point it at the remote sensor on the player.



You can control TVs and AV receivers using the supplied remote. See page 30.

### Notes

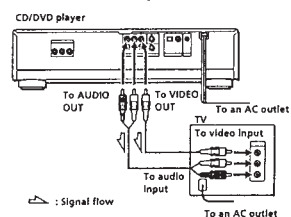
- Do not leave the remote in an extremely hot or humid place.
- Do not drop any foreign object into the remote casing, particularly when replacing the batteries.
- Do not expose the remote sensor to direct sunlight or lighting apparatus. Doing so may cause a malfunction.
- If you will not use the remote for an extended period of time, remove the batteries to avoid possible damage from battery leakage and corrosion.

### Hooking Up the System

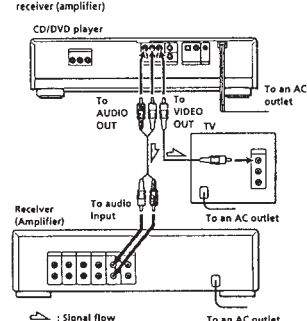
#### Overview

This section describes how to hook up the CD/DVD player to a TV (with audio/video input jacks) and/or a receiver (amplifier). You cannot connect this player to a TV without a video input connector. Be sure to turn off the power of each component before making the connections.

#### To listen to the sound through TV speakers

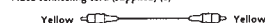


#### To listen to the sound through speakers connected to a receiver (amplifier)

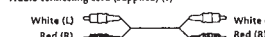


#### What cords will I need?

Video connecting cord (supplied) (1)



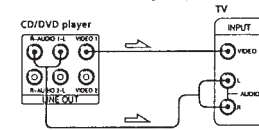
Audio connecting cord (supplied) (1)



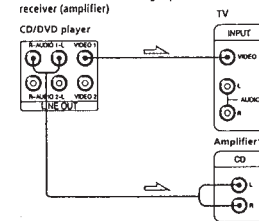
#### Hookups

When connecting the cords, be sure to match the color-coded cord to the appropriate jacks on the components: Yellow (video) to Yellow, Red (right) to Red and White (left) to White. Be sure to make connections firmly to avoid hum and noise.

#### To listen to the sound through TV speakers



#### To listen to the sound through speakers connected to a receiver (amplifier)

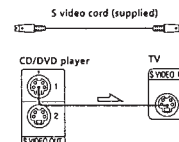


• Make the same connections when your receiver (amplifier) conforms to "Pro Logic."

#### Notes

- Do not connect this player to a video deck. If you view the pictures on your TV after making the connections shown on the right, a picture noise may appear.
- Depending on the TV or receiver (amplifier), sound distortion may occur because the audio output level is high. In this case, set "AUDIO ATT" in "INITIAL SETUP 2" to "ON" in the setup display. For details, see page 37.

If your TV has an S video input connector. Connect the component via the S VIDEO OUT connector using the S video cord (supplied) instead of the video connecting cord. You will get a better picture.

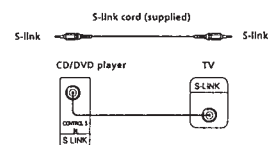


If you connect the player to a monitor or projector with component video input connectors that conform to output signals from the COMPONENT VIDEO OUT (Y, Pb/B-Y, Pa/R-Y) connectors on the player. Connect the component via the COMPONENT VIDEO OUT connectors using three video connecting cords (not supplied) of the same kind. You will get a better picture.



Note  
Refer to the instructions supplied with the component to be connected.

If your TV has an S-link connector. You can control the CD/DVD player from the TV. Connect the TV via the S-LINK connector using the S-link cord (supplied). Refer to the instructions supplied with the TV to be connected.



(Continued)

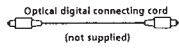
If you have a digital component such as a receiver (amplifier) with a digital connector, DAT or MD. Connect the component via the DIGITAL OUT OPTICAL or COAXIAL connector using an optical or coaxial digital connecting cord (not supplied).

If you have a digital component with a built-in DTS or Dolby Digital (AC-3) decoder. Connect the component via the DIGITAL OUT OPTICAL or COAXIAL connector using an optical or coaxial digital connecting cord (not supplied). For details on hookups and settings, see page 32.

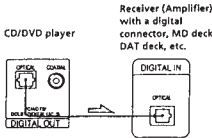
When you play a DVD, set the items in "INITIAL SETUP 3" in the setup display as follows (page 38):

- DIGITAL OUT: ON
- DOLBY DIGITAL: D-PCM
- DTS: OFF.

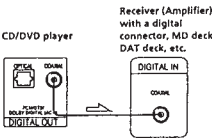
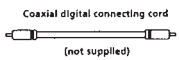
■ When using an optical digital connecting cord



Take off the cap and plug in the optical digital connecting cord.



■ When using a coaxial digital connecting cord



- Notes
- Refer to the instructions supplied with the component to be connected.
  - You cannot make digital audio recordings of discs recorded in DTS and Dolby Digital (AC-3) format directly using an MD deck or DAT deck.

When you make the connections above, do not set the items in "INITIAL SETUP 3" in the setup display as follows:

- DOLBY DIGITAL: DOLBY DIGITAL
- DTS: ON.

If you set even one of them, a loud noise will suddenly come out from the speakers, affecting your ears or causing the speakers to be damaged.

Necessary Setup Before Using the Player

Some setups are necessary for the player depending on the TV or other components to be connected. For details on using the setup display, see page 34. For details on each setup display item, see pages 35 to 38.

To enjoy DTS or Dolby Digital (AC-3) surround sound, see page 32.

■ To connect the player to a wide-screen TV

In the setup display, set "TV TYPE" in "INITIAL SETUP 1" to "16:9". For details, see page 36.

■ To connect the player to a normal TV

In the setup display, set "TV TYPE" in "INITIAL SETUP 1" to "4:3 LETTER BOX" (default setting) or "4:3 PAN SCAN." For details, see page 36.

■ To listen to the sound through speakers connected to a receiver (amplifier) with a digital connector or to output the sound to a digital component such as a DAT or MD deck

When you play a DVD, set "DIGITAL OUT" to "ON" and then, set "DOLBY DIGITAL" to "D-PCM" and "DTS" to "OFF" in "INITIAL SETUP 3" in the setup display. These are default settings. For details, see page 38.

■ To connect the player to a digital component with a built-in Dolby Digital decoder

Set "DIGITAL OUT" to "ON" (default setting) and set "DOLBY DIGITAL" to "DOLBY DIGITAL", in "INITIAL SETUP 3" in the setup display. For details, see page 32.

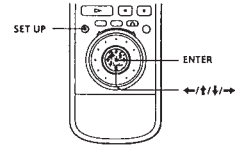
■ To connect the player to a digital component with a built-in DTS decoder

Set "DIGITAL OUT" to "ON" (default setting) and set "DTS" to "ON", in "INITIAL SETUP 3" in the setup display. For details, see page 32.

Use the setup display to change the various settings for the picture and sound. For details, see page 34.

Selecting the Language for On-screen Display

You can select the language for the setup display or the messages displayed on the screen. Default setting is "ENGLISH."



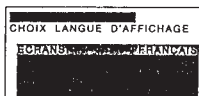
1 Press SET UP and select "SET" using  $\leftarrow/\rightarrow$ , and then press ENTER.



2 Select "OSD" using  $\uparrow/\downarrow$ , then press  $\rightarrow$  or ENTER.



3 Select the language you want using  $\uparrow/\downarrow$ , then press ENTER.

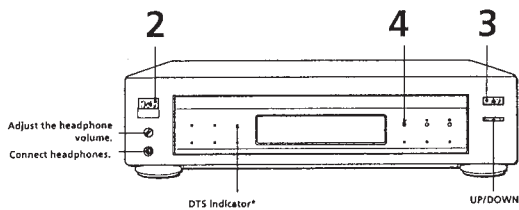


To cancel using the setup display on the way Press SET UP.

Note  
The languages you can select are the ones displayed in step 2. For details, see page 35.

Basic Operations

Playing a DVD



The operating procedure of CDs or VIDEO CDs is different from that of DVDs. For details, see pages 14 to 17.

You can turn on the player using the remote. Press I/O when the indicator above the I/O button on the front panel is lit in red.

DTS indicator lights up when you play DTS sound tracks on a DVD. In this case, no sounds will come out from the LINE OUT (AUDIO 1, 2) and PHONES connectors. To enjoy the DTS sounds, you have to connect an audio component with a built-in DTS decoder (see page 32).

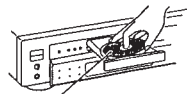
After following Step 4 A DVD menu or title menu may appear on the TV screen (see page 13).

1 Make settings on your TV. Turn on the TV and select the video input so that you can view the pictures from this player.

When using an amplifier Turn on the amplifier and select the appropriate position so that you can listen to the sound from this player.

2 Press I/O to turn on the player. The indicator (red) above the I/O button changes to green and the front panel display lights up.

3 Press  $\Delta$ , and place the disc on the disc tray.



With the playback side facing down

4 Press  $\blacktriangleright$ . The disc tray and front panel close, and the player starts playback (Continuous Play). Adjust the volume on the TV or the amplifier.

To open or close the front panel Press UP/DOWN on the player.

Depending on the DVD, some operations may be different or restricted. Refer to the instructions supplied with your disc.

Note  
If you leave the player or the remote in pause or stop mode for 15 minutes, the screen saver image appears automatically. To disappear the screen saver, press  $\blacktriangleright$ . (If you want to set the screen saver function to off, see page 36.)

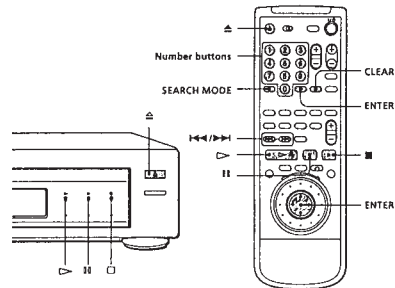
Note  
When "RESUME" appears on the front panel display You can resume playback from the point where you stopped the DVD. For details on playing from the beginning of the disc, see page 25.

Note  
You may not be able to do Resume Play depending on the DVD.

Note  
What are chapter and title? See page 5.

Note  
Depending on the DVD, you may not be able to do some of the operations described on the right.

Note  
Each time you press SEARCH MODE "CHAPTER SEARCH", "TITLE SEARCH" and "TIME SEARCH" appear on the TV screen.



To	Press
Stop	$\blacksquare$
Pause	II
Resume play after pause	II or $\blacktriangleright$
Go to the next chapter in Continuous Play mode	$\blacktriangleright$
Go back to the preceding chapter in Continuous Play mode	$\blacktriangleleft$
Select the chapter	1 SEARCH MODE repeatedly until "CHAPTER SEARCH" appears on the TV screen. 2 Number buttons to select the chapter number, then ENTER or $\blacktriangleright$ .
Select the title	1 SEARCH MODE repeatedly until "TITLE SEARCH" appears on the TV screen. 2 Number buttons to select the title number, then ENTER or $\blacktriangleright$ .
Locate a point using the time code	1 SEARCH MODE repeatedly until "TIME SEARCH" appears on the TV screen. 2 Number buttons to enter a time code, then ENTER or $\blacktriangleright$ .
Stop play and remove the disc	$\Delta$

If you have made a mistake when you press the number button. Press CLEAR, then the correct number button.

Basic Operations

DVD

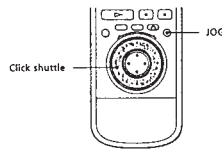
SEARCH MODE

ENTER

ENTER

**To play at various speeds/frame-by-frame**

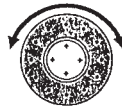
Using the click shuttle and the JOG button/indicator, you can playback a DVD with various speed or frame-by-frame. Each time you press JOG, it changes between shuttle mode and jog mode.



- Notes**
- Depending on the DVD, you may not be able to do some of the operations described on the right.
  - When you play back a DVD at twice the normal speed in either direction, the sounds of the picture will come out from the LINE OUT (AUDIO 1, 2) connectors. The sounds are lower than the ones at normal speed. In this case, no sounds come out from the DIGITAL OUT OPTICAL and COAXIAL connectors.

■ To change the playback speed (Shuttle mode)  
Turn the click shuttle. The playback speed changes depending on the turning direction and angle as follows:

- FF2▶▶ (about 30 times the normal speed)
- FF1▶▶ (about 10 times the normal speed)
- x2▶▶ (about twice the normal speed)
- PLAY▶ (Normal speed)
- SLOW1▶ (playback direction)
- SLOW2▶ (playback direction - slower than "SLOW1▶")
- PAUSE||
- SLOW2◀ (opposite direction - slower than "SLOW1◀")
- SLOW1◀ (opposite direction)
- x2◀◀ (about twice the normal speed : opposite direction)
- FR1◀◀ (about 10 times the normal speed)
- FR2◀◀ (about 30 times the normal speed)



If you turn the click shuttle quickly, the playback speed goes to FF2▶▶/FR2◀◀ at once.

■ To play the DVDs frame-by-frame changing the playback speed (Jog mode)

- Press JOG.
- JOG lights up during jog mode.
- Turn the click shuttle.

Depending on the turning speed, the playback goes to frame-by-frame toward the turning direction of the click shuttle. If you turn the click shuttle with constant speed for a while, the playback speed goes to slow or normal.

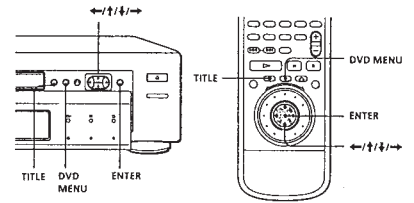
■ To return to Continuous Play  
Press ▷.

**Note**  
If you don't operate the click shuttle for about 20 seconds after pressing JOG, it returns to shuttle mode.

- Notes**
- Depending on the DVD, you may not be able to select the title.
  - Depending on the DVD, a "title menu" may simply be called a "menu" or "title" in the instructions supplied with the disc. "Press ENTER" may also be expressed as "Press SELECT."

**Using the Title Menu**

A DVD is divided into long sections of a picture or a music piece called "titles." When you play the DVD which contains several titles, you can select the title you want using the title menu.



- Press TITLE.  
The title menu appears on the TV screen. The contents of the menu varies from disc to disc.
- Press ◀/▶/◂/▸ to select the title you want to play.  
Depending on the disc, you can use the number buttons to select the title.
- Press ENTER.  
The player starts playing the selected title.

**Using the DVD menu**

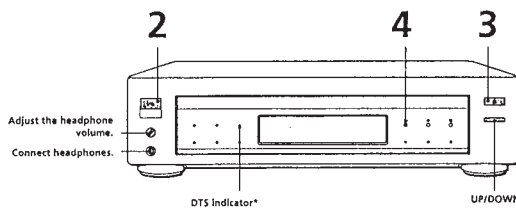
Some DVDs allow you to select the disc contents using the menu. When you play these DVDs, you can select the language for the subtitles, the language for the sound, etc., using the DVD menu.

- Press DVD MENU.  
The DVD menu appears on the TV screen. The contents of the menu vary from disc to disc.
- Press ◀/▶/◂/▸ to select the item you want to change.  
Depending on the disc, you can use the number buttons to select the item.
- To change other items, repeat Step 2.
- Press ENTER.

**Note**  
If you want to select the language for the DVD menu. Change the setting using "LANGUAGE SETUP" in the setup display. When you select a language that is not recorded on the DVD, one of the recorded languages is automatically selected (see page 35).

**Note**  
Depending on the DVD, a "DVD menu" may simply be called a "menu" in the instructions supplied with the disc.

**Playing a CD/VIDEO CD**



- The operating procedure of DVDs is different from that of CDs or VIDEO CDs. For details, see pages 10 to 13.

- You can turn on the player using the remote. Press I/O when the indicator above the I/O button on the front panel is lit in red.
- Do not play DTS sound tracks on a CD without connecting the player to an audio component with a built-in DTS decoder. DTS indicator does not light up when you play DTS sound tracks on a CD, even if the player outputs DTS signals via the DIGITAL OUT OPTICAL and COAXIAL connectors. In this case, a loud noise will come out from the LINE OUT (AUDIO 1, 2) and PHONES connectors. To enjoy the DTS sounds, you have to connect an audio component with a built-in DTS decoder (see page 32).

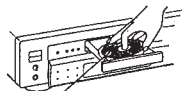
After following Step 4 The menu screen may appear on the TV screen depending on the VIDEO CD. You can play the disc interactively, following the instructions on the menu screen. (FBC Playback, see page 17)

- Make settings on your TV.  
Turn on the TV and select the video input so that you can view the pictures from this player.

When using an amplifier  
Turn on the amplifier and select the appropriate position so that you can listen to the sound from this player.

- Press I/O to turn on the player.  
The indicator (red) above the I/O button changes to green and the front panel display lights up.

- Press ▲, and place the disc on the disc tray.



With the label side facing up

- Press ▷.  
The disc tray and front panel close, and the player starts playback (Continuous Play). Adjust the volume on the TV or the amplifier.

To open or close the front panel  
Press UP/DOWN on the player.

**Note**  
If you leave the player or the remote in pause or stop mode for 15 minutes, the screen saver image appears automatically. To disappear the screen saver, press ▷. (If you want to set the screen saver function to off, see page 36.)

When "RESUME" appears on the front panel display  
You can resume playback from the point where you stopped the CD/VIDEO CD. For details on playing from the beginning of the disc, see page 25.

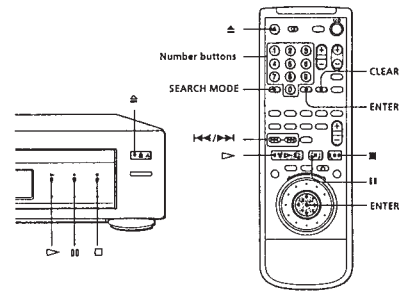
What is a track?  
See page 5.

What is an index?  
See page 5.

What is a scene?  
See page 5.

If you want to change the search mode  
Press SEARCH MODE. Each time you press in case of a VIDEO CD, "SCENE SEARCH", "TRACK SEARCH" and "V. (VIDEO) INDEX SEARCH" appear on the TV screen. In case of a CD, only "TRACK SEARCH" appears.

**Note**  
Some discs do not allow you to start playing from a particular scene. In this case, if you do Scene Search before you start playing, the player starts playing from scene 1. If you do Scene Search while playing a disc, the player starts playing from the current scene.



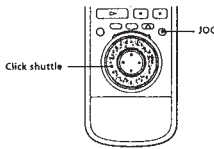
To	Press
Stop	■
Pause	
Resume play after pause	or ▷
Go to the next track in Continuous Play mode	▶▶
Go back to the preceding track in Continuous Play mode	◀◀
Select the track	1 SEARCH MODE repeatedly until "TRACK SEARCH" appears on the TV screen. 2 Number buttons to select the track number, then ENTER or ▷.
Select the scene before you start playing a VIDEO CD with PBC functions and during PBC playback (Scene Search)	1 SEARCH MODE repeatedly until "SCENE SEARCH" appears on the TV screen. 2 Number buttons to select the scene number, then ENTER or ▷. (To check the current scene number, press DISPLAY. The scene number appears at the left top of the TV screen.)
Stop play and remove the disc	▲

If you have made a mistake when you press the number button.  
Press CLEAR, then the correct number button.

Depending on the VIDEO CD, some operations may be different or restricted. Refer to the instructions supplied with your disc.

To play at various speeds / frame-by-frame

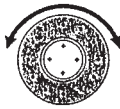
Using the click shuttle and the JOG button/indicator, you can playback a CD/VIDEO CD with various speed or frame-by-frame. Each time you press JOG, it changes between shuttle mode and jog mode.



- Notes**
- Depending on the VIDEO CD, you may not do some of the operations described on the right.
  - When you play a VIDEO CD, there is no sound except for the playback at normal speed.

■ To change the playback speed (Shuttle mode)  
Turn the click shuttle. The playback speed changes depending on the turning direction and angle as follows:

- FF2 (Faster than "FF1")
- FF1 (Faster than "FF2")
- x2 (about twice the normal speed)
- PLAY (Normal speed)
- SLOW1 (playback direction) - VIDEO CD Only -
- SLOW2 (playback direction) - Slower than "SLOW1" - VIDEO CD Only -
- PAUSE
- FR1 (Faster than "FR2")
- FR2 (Faster than "FR1")



If you turn the click shuttle quickly, the playback speed goes to FF2/FR2 at once.

■ To play the VIDEO CDs frame-by-frame changing the playback speed (Jog mode - VIDEO CD Only)

- Press JOG. JOG lights up during jog mode.
- Turn the click shuttle.

Depending on the turning speed, the playback goes to frame-by-frame toward the playback direction only. If you turn the click shuttle with constant speed for a while, the playback speed goes to slow or normal.

■ To return to Continuous Play  
Press C.

**Note**  
If you don't operate the click shuttle for about 20 seconds after pressing JOG, it returns to shuttle mode.

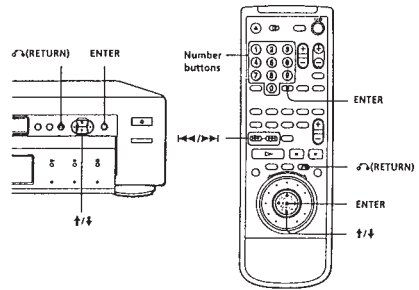
⚡ When playing VIDEO CDs with PBC functions  
PBC playback starts automatically.

- ⚡ To cancel PBC playback of a VIDEO CD with PBC functions and play the disc in Continuous Play mode  
There are two ways.
- Before you start playing, select the track you want using  $\leftarrow$  or  $\rightarrow$ , then press ENTER or C.
  - Before you start playing, select the track number using the number buttons on the remote, then press ENTER or C.
- "Play without PBC" appears on the TV screen and the player starts Continuous Play. You cannot play still pictures such as a menu screen. To return to PBC playback, press  $\blacksquare$  twice then press C.

**Note**  
Depending on the VIDEO CD, "Press ENTER" in Step 3 may be expressed as "Press SELECT" in the instructions supplied with the disc.

Playing VIDEO CDs with PBC Functions (PBC Playback - VIDEO CD Only)

When playing VIDEO CDs with PBC functions (Ver. 2.0 discs), you can enjoy simple interactive operations, operations with search functions, etc. PBC Playback allows you to play VIDEO CDs interactively, following the menu screen on the TV screen. On this player, you can use the number buttons, ENTER,  $\leftarrow$ ,  $\rightarrow$ ,  $\uparrow$ / $\downarrow$  and  $\text{RETURN}$  during PBC Playback.



- Start playing a VIDEO CD with PBC functions, following Steps 1 to 4 in "Playing a CD/VIDEO CD" on page 14.
- Select the item number you want.  
On the player  
Press  $\uparrow$ / $\downarrow$  to select the item number.  
On the remote  
Press the number button of the item you want.
- Press ENTER.
- Follow the instructions on the menu screen for interactive operations.  
Refer to the instructions supplied with the disc, as the operating procedure may differ according to the VIDEO CD.

Going back to the menu screen

Press  $\text{RETURN}$ ,  $\leftarrow$ , or  $\rightarrow$ .

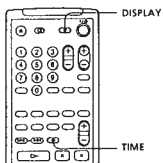
Playing Discs in Various Modes

Playing Discs in Various Modes

Using the On-Screen Display



You can check the operating status of the player and the information about the disc using the on-screen display on the TV screen.

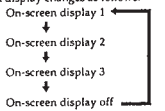


When playing back or stopping a DVD

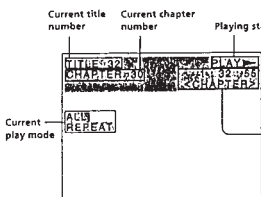
**DVD**

Press DISPLAY.

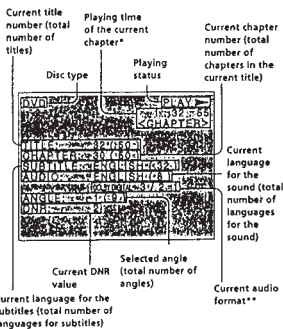
Each time you press the DISPLAY button, the on-screen display changes as follows:



■ Display information of the on-screen display 1 mode

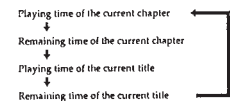


■ Display information of the on-screen display 2 mode

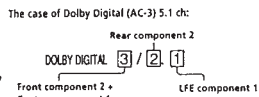


**Note**  
Some information may not be displayed depending on a DVD.

\* In display 1 or 2 mode, each time you press TIME the information changes as shown below.

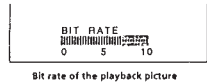


\*\* "PCM", "DTS" or "DOLBY DIGITAL" is displayed. In "DOLBY DIGITAL" case, the channels in the playing track are displayed by number as follows.



■ Display information of the on-screen display 3 mode

While playing a disc, the approximate bit rate of the playback picture is always displayed by Mbps (Mega bit per second).



⚡ What is bit rate?

Bit rate refers to the amount of video data per second in a disc. The higher the bit rate is, the larger the amount of data. However, this does not always mean that you can get higher quality pictures.

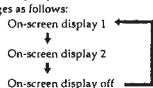
■ Display information of the on-screen display off mode  
No information is displayed. (Messages, etc., will be displayed.)

When playing back or stopping a CD/VIDEO CD

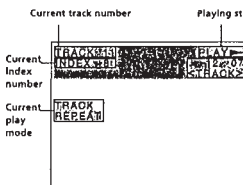
**CD VIDEO CD**

Press DISPLAY.

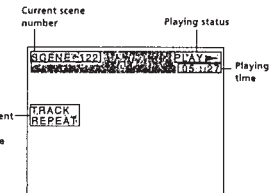
Each time you press the button, the on-screen display changes as follows:



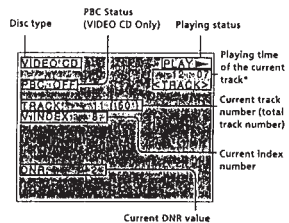
■ Display information of the on-screen display 1 mode



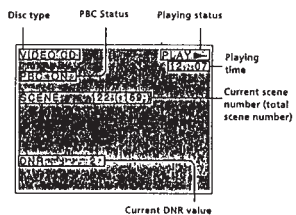
• During PBC playback (VIDEO CD Only)



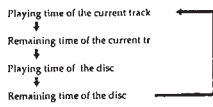
■ Display information of the on-screen display 2 mode



• During PBC playback (VIDEO CD Only)



- In display 1 or 2 mode, each time you press TIME, the information changes as shown below.



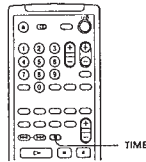
While you are doing Shuffle Play, Program Play, or PBC Playback, the playing time of the disc and the remaining time of the disc are not displayed.

- Display information of the on-screen display off mode  
No information is displayed. (Messages, etc., will be displayed.)

### Using the Front Panel Display

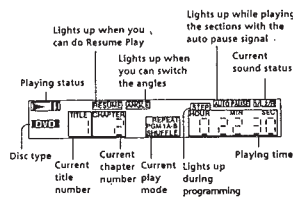


You can check information about the disc, such as the total number of the titles or the tracks or remaining time, using the front panel display.



#### When playing back a DVD

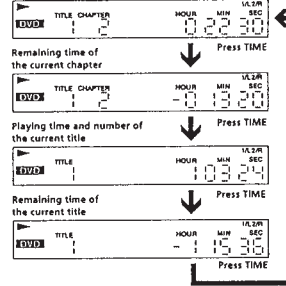
- Display information while playing the disc



- Checking the remaining time

Press TIME.  
Each time you press TIME while playing the disc, the display changes as shown in the chart to the right. The time information in the on-screen display 1 and 2 also changes each time you press TIME.

#### Playing time and number of the current chapter

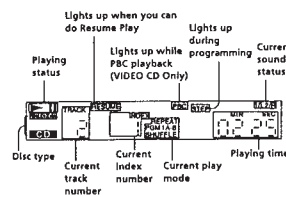


#### Notes

- Depending on the DVD, the chapter number or time may not appear.
- While you are doing Shuffle Play or Program Play, the playing time of the disc and the remaining time of the disc are not displayed.

#### When playing back a CD/VIDEO CD

- Display information while playing a disc

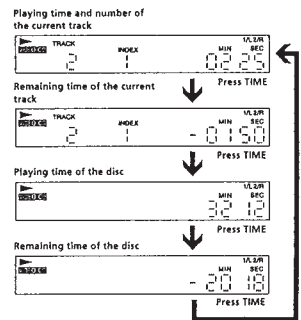


#### When playing VIDEO CDs with PBC functions

The current scene number is displayed instead of the current track number and the current index number. In this case, the front panel display does not change when you press TIME.

#### Checking the remaining time

Press TIME.  
Each time you press TIME while playing a disc, the display changes as shown in the chart below. The time information in the on-screen display 1 and 2 also changes each time you press TIME.

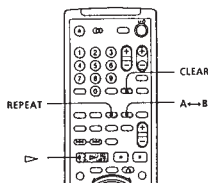


#### Note

While you are doing Shuffle Play, Program Play or PBC playback, the playing time of the disc and the remaining time of the disc are not displayed.

### Playing Repeatedly (Repeat Play)

You can play all the titles/tracks on a disc, a single title/chapter/track or a specific portion repeatedly.



#### Repeating all the titles or all the tracks on a disc

In Shuffle or Program Play mode, the player repeats the titles or tracks in the shuffled or programmed order.

You cannot do Repeat Play during PBC playback of VIDEO CDs (page 17). You may not be able to do Repeat Play depending on the DVD.

Press REPEAT during playback.

"ALL REPEAT" appears on the screen and "REPEAT" appears on the front panel display. The player repeats the titles/chapters/tracks as follows:

When the disc is played in	The player repeats
Continuous Play (page 10, 14)	All the titles/all the tracks
Shuffle Play (page 23)	All the titles or tracks in random order
Program Play (page 24)	Programmed titles/chapters/tracks

To cancel repeating all the titles or all the tracks on a disc Press CLEAR.

#### Repeating the current title or chapter

##### DVD

You can repeat only the current title or chapter in Continuous Play mode. You may not be able to do Repeat Play depending on the DVD.

- Repeating the current title  
While the title you want is being played, press REPEAT repeatedly until "TITLE REPEAT" appears on the TV screen. The player repeats the current title.
- Repeating the current chapter  
While the chapter you want is being played, press REPEAT repeatedly until "CHAPTER REPEAT" appears on the TV screen. The player repeats the current chapter.

"REPEAT 1" appears on the front panel display.

"CHAPTER" is displayed when you select the current chapter



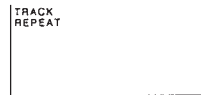
To cancel repeating the current title or chapter Press CLEAR.

##### VIDEO CD

You can repeat only the current track in Continuous Play mode.

While the track you want is being played, press REPEAT until "TRACK REPEAT" appears on the TV screen.

"REPEAT 1" appears on the front panel display and the player repeats the current track.



To cancel repeating the current track Press CLEAR.

Notes  
Repeat play is canceled when you turn the power off.

#### Repeating a specific portion

##### (A→B Repeat) DVD VIDEO CD

You can play a specific portion of a title, chapter, track repeatedly. This is useful when you want to memorize lyrics.

During PBC Playback of VIDEO CDs (page 17), this function is available only while playing moving pictures. You may not be able to do Repeat Play depending on the DVD.

- During playback, when you find the starting point (point A) of the portion to be played repeatedly, press A→B. The starting point (point A) is set. "A-B REPEAT" appears on the TV screen and "B" flashes.



"REPEAT A-" also appears on the front panel display and "B" flashes.

- When you reach the ending point (point B), press A→B again. "A-B REPEAT" on the TV screen disappears and the player starts repeating this specific portion.

"REPEAT A-B" appears on the front panel display during A→B repeat play.

To cancel A→B Repeat Press CLEAR.

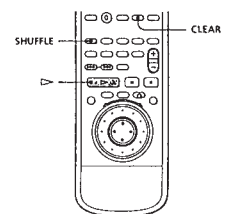
To cancel setting halfway Press CLEAR.

- Notes
- A→B Repeat is canceled when:
  - you open or close the disc tray
  - you turn the power off
- When you set A→B Repeat, the settings for Shuffle Play and Program Play are canceled.
- You may not be able to set A→B Repeat, depending on the scene of a DVD or a VIDEO CD.

### Playing in Random Order (Shuffle Play)

##### DVD VIDEO CD

You can have the player "shuffle" titles or tracks and play them in a random order.



- Press SHUFFLE.
- Press ▷. (During playback, the player starts Shuffle Play when you follow the step 1.)

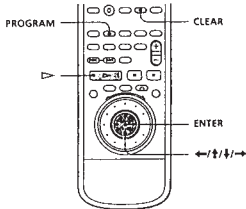
To cancel Shuffle Play Press CLEAR.

- Notes
- The Shuffle Play is canceled when:
  - you open or close the disc tray
  - you turn the power off
- You may not be able to do Shuffle Play depending on the DVD.
- When you play a DVD, you can do Shuffle Play only by titles.

### Creating Your Own Program (Program Play)

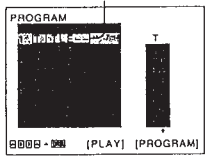


You can arrange the order of the titles, chapters or tracks on the disc and create your own program. The program can contain up to 99 titles, chapters and tracks.

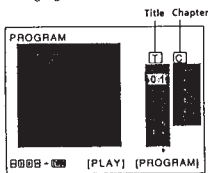


1 Press PROGRAM. The programming display appears.

"TRACK\_" is displayed when you play a VIDEO CD or a CD.

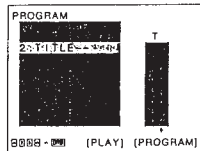
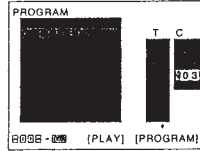


2 Press →. "01" is highlighted.

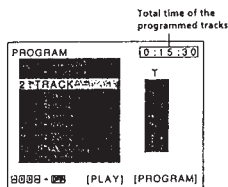


3 Select the title, chapter or track you want to program using ↑/↓, then press ENTER. For example, select title or track 2. (You can also use the number buttons and ENTER button to select. In this case, the selected number is displayed on the screen.)

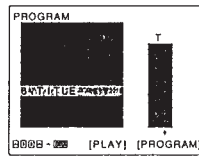
■ When playing a DVD  
When both titles and chapters are recorded on the disc, select the title, then the chapter.



■ When playing a VIDEO CD or CD  
Select the track you want to program.



4 To program other titles, chapters or tracks, repeat Step 3. The programmed titles, chapters or tracks are displayed from 02 in order.



5 Press ▷ to start Program Play.

To cancel Program Play  
Press CLEAR.

To cancel programming  
Press PROGRAM.

To change programming  
1 In Step 2, select the program number of the title, chapter or track you want to change using ↑/↓.  
2 Follow Step 3 for new programming.

To cancel the programmed order  
To cancel all the titles, chapters or tracks in the programmed order, select "ALL CLEAR" in Step 2.  
To cancel the selected program, select the program using ↑/↓ in Step 2 then press CLEAR, or select "-" in Step 3 and then press ENTER.

⚡ The program remains even after the Program Play ends  
When you press ▷, you can play the same program again.

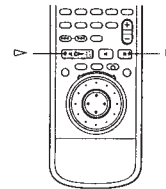
💡 You can do Repeat Play or Shuffle Play of the programmed titles, chapters or tracks  
During Program Play, press REPEAT or SHUFFLE.

Notes  
• The number of titles, chapters or tracks displayed are that of the titles, chapters or tracks recorded on a disc.  
• The program is canceled when:  
- you open or close the disc tray  
- you turn the power off  
• You may not be able to do Program Play depending on the DVD.  
• While you are doing PBC playback, you cannot set a program unless you stop playback once.

### Resuming Playback from the Point Where You Stopped a Disc (Resume Play)



The player stores the point where you stopped a disc if "RESUME" appears on the front panel display. In this case, you can resume playback from that point. As long as you do not open the disc tray, Resume Play is available even if you turn the power off.



1 While playing a disc, press ■ to stop playback. "RESUME" appears in the front panel display and "When playing next time, disc restarts from point you stopped." appears on the TV screen. If "RESUME" does not appear, Resume Play is not available.

2 Press ▷.  
The player starts playback from the point you stopped the disc in Step 1.

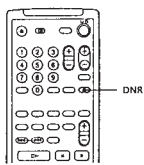
💡 To play from the beginning of the disc  
When "RESUME" appears on the front panel display before you start playing, press ■ to turn off "RESUME," then press ▷.

Notes  
• You may not do Resume Play depending on the DVD.  
• Resume Play is not available in Shuffle or Program Play mode.  
• Depending on where you stopped the disc, the player may resume playback from a different point.  
• The point where you stopped playing is cleared when:  
- you open or close the disc tray  
- you disconnect the AC power cord  
- you change the play mode  
- you start playback after selecting a title, chapter or track  
- you change the settings of "DVD MENU", "AUDIO" or "SUBTITLE" in "LANGUAGE SETUP" in the setup display  
- you change the settings of "TV TYPE", "PARENTAL CONTROL" in "INITIAL SETUP 1" in the setup display

### Reducing the Picture Noise (DNR: Digital Video Noise Reduction)



You can make the picture clearer by reducing the picture noise.



Press DNR. Each time you press the button, the value for DNR changes as follows:  
0 → 1 → 2 → 3

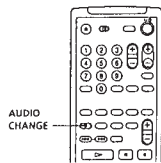
When the value is "0", the DNR is set to off. As the value increases, the picture noise will be reduced. However, afterimages may increase.

Notes  
• Depending on the disc, the effect may be difficult to tell.  
• If the afterimages appear on the TV screen, set the noise reduction function to off on your TV. Then set DNR to "0" on the player.

### Changing the Sounds



With DVDs on which multilingual sounds are recorded, you can select the language you want while playing the DVD. With multiplex VIDEO CDs, you can select the sound from the right or left channel and listen to the sound of the selected channel through both the right and left speakers. In this case, the sound loses the stereo effect.



Press AUDIO CHANGE while playing a disc. Each time you press the button, the indication and the language/sound from the speakers change as follows:

■ When playing a DVD  
AUDIO 1 → AUDIO 2 → ...



■ When playing a VIDEO CD or a CD

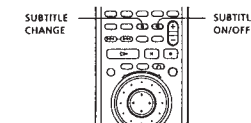
1/L: The sound of the left channel  
↓  
2/R: The sound of the right channel  
↓  
Stereo: The standard stereo sound (1/L/2/R)

Notes  
• Depending on the DVD, you may not be able to change the languages even if multilingual sounds are recorded on the DVD.  
• While playing the CD/VIDEO CD, the standard stereo playback will be resumed when:  
- you open or close the disc tray  
- you turn the power off  
• While playing the DVD, the sound may be changed when:  
- you open or close the disc tray  
- you change the title  
• If the language is indicated in a four-digit number, refer to the Language Code List on page 49.

### Displaying the Subtitles



With DVDs on which subtitles are recorded, you can turn the subtitles on and off whenever you want while playing the DVD. With DVDs on which multilingual subtitles are recorded, you can change the subtitles whenever you want while playing the DVD.



Turning the Subtitles On and Off

Press SUBTITLE ON/OFF while playing a DVD. Subtitles appear on the TV screen.

To turn off the subtitles  
Press SUBTITLE ON/OFF again.

Notes  
• When playing the DVD on which no subtitles are recorded, no subtitles appear even if you press SUBTITLE ON/OFF.  
• Depending on the DVD, you may not be able to turn the subtitles on even if they are recorded on the DVD.  
• Depending on the DVD, you may not be able to turn the subtitles off.  
• If the language is indicated in a four-digit number, refer to the Language Code List on page 49.

### Changing the Subtitle Language

When subtitles are turned off, press SUBTITLE ON/OFF to turn on the subtitles.

While playing a DVD, press SUBTITLE CHANGE repeatedly until the subtitles you want appear on the TV screen.

SUBTITLE 1 → SUBTITLE 2 → ...

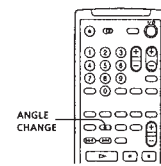


Notes  
• The type and number of languages for subtitles vary from disc to disc.  
• Depending on the DVD, you may not be able to change the subtitles even if multilingual subtitles are recorded on the DVD.  
• While playing the DVD, the subtitle may be changed when:  
- you open or close the disc tray  
- you change the title

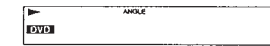
### Changing the Angles



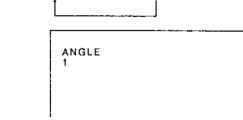
With DVDs on which various angles (multi-angles) for a scene are recorded, you can change the angles whenever you want while playing the DVD.



When "ANGLE" appears on the front panel display while playing a DVD, press ANGLE CHANGE repeatedly until you get the angle you want.



ANGLE 1 → ANGLE 2 → ...



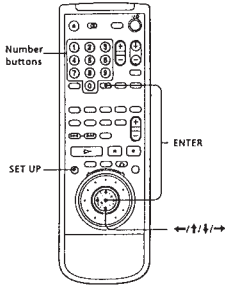
💡 You can specify the angle beforehand  
Specify the angle when "ANGLE" is not displayed on the front panel display. When a scene on which multi-angles are recorded comes, the angle is automatically selected.

Notes  
• The number of angles varies from disc to disc or from scene to scene. The number of angles that can be changed on a scene is that of angles recorded for that scene.  
• Depending on the DVD, you may not be able to change the angles even if multi-angles are recorded on the DVD.

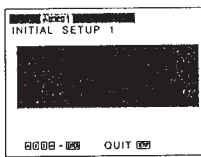


### Limiting Playback by Children (Parental Control)

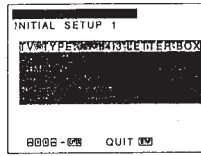
Playing some DVDs can be limited depending on the age of users. The "Parental Control" function allows you to set a playback limitation level.



1 Press SET UP to display the setup display on the TV screen before playing.

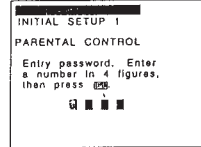


2 Select "INITIAL SETUP 1" using  $\leftarrow/\rightarrow$ , then press ENTER.

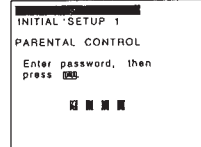


3 Select "PARENTAL CONTROL" using  $\uparrow/\downarrow$ , then press ENTER.

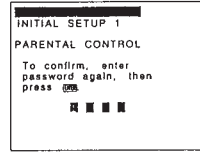
■ When you have not entered a password yet  
The display for entering a password appears.



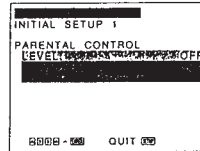
■ When you have already entered a password  
The display for confirming the password appears.  
Skip Step 4.



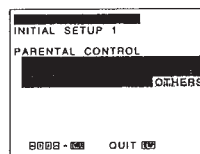
4 Enter a password in 4 figures using the number buttons, then press ENTER.  
The figures change to asterisks (\*), and the display for confirming the password appears.



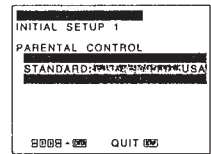
5 To confirm your password, enter it using the number buttons, then press ENTER.  
The display for setting the playback limitation level and changing the password appears.



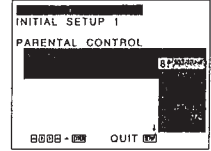
6 Select "STANDARD" using  $\uparrow/\downarrow$ , then press  $\rightarrow$ .



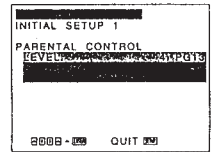
7 Select an area as the standard for playback limitation level using  $\uparrow/\downarrow$ , then press  $\rightarrow$ .  
When you select "OTHERS", select and enter the standard code in the table below using number buttons.



8 Select "LEVEL" using  $\uparrow/\downarrow$ , then press  $\rightarrow$ .



9 Select the level you want using  $\uparrow/\downarrow$ , then press ENTER.



The lower the value is, the more strict the limitation.

To return to the normal screen  
Press SET UP.

To turn off the Parental Control function and play the DVD after entering your password  
Set "LEVEL" to "OFF" in Step 9, then press  $\rightarrow$ .

(Continued)

To change the password  
1 In Step 5, select "CHANGE PASSWORD" using  $\uparrow/\downarrow$ , then press  $\rightarrow$  or ENTER.  
The display for changing the password appears.  
2 Follow Steps 4 and 5 to enter a new password.

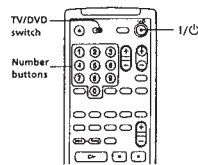
If you have forgot your password  
Enter six digit number "199903" in Step 4 to clear the current password. To enter a new password, follow the procedure from Step 4 again.

- Notes
- When you play DVDs which do not have the Parental Control function, playback cannot be limited on this player.
  - When you do not set a password, you cannot change the settings for playback limitation.
  - Depending on the DVD, you may be asked to change the parental control level while playing the disc. In this case, enter the password, then change the level. When you stop playing the DVD, the level returns to the original level.

Standard	Code number
Austria	2046
Belgium	2057
Canada	2079
China	2092
Denmark	2115
Finland	2165
France	2174
Germany	2109
Hong Kong	2219
Indonesia	2238
Italy	2254
Japan	2276
Malaysia	2263
Netherlands	2376
Norway	2379
Philippines	2424
Singapore	2501
Spain	2149
Sweden	2499
Switzerland	2086
Taiwan	2543
Thailand	2528
United Kingdom	2184

### Controlling the TV or the AV receiver with the Supplied Remote

If you adjust the remote signal, you can control your TVs with the supplied remote. Default setting is to control Sony TVs with the  $\blacksquare$  mark. When you connect the player to an AV receiver, you can also adjust the volume of the receiver with the supplied remote.



#### Controlling TVs with the remote

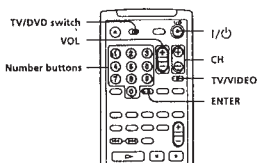
- Slide TV/DVD switch to TV.
- Hold down I/POWER, and enter your TV's manufacturer's code in the table below using the number buttons. Then release I/POWER.

Code numbers of controllable TVs  
If more than one code number is listed, try entering them one at a time until you find the one that works with your TV.

- Notes
- If you enter a new code number, the code number previously entered will be erased.
  - When you replace the batteries of the remote commander, the code number automatically resets to 01 (Sony). Reset the appropriate code number.

Manufacturer	Code number	Manufacturer	Code number
Sony (default)	01	Panasonic	06,19
Akai	04	Philco	03,04
AOC	04	Philips	08
Centurion	12	Pioneer	16
Coronado	03	Portland	03
Curio-Mathes	12	Quasar	06,18
Daytron	12	Radio Shack	05,14
Emerson	03,04,14	RCA	04,10
Fisher	11	Sampo	12
General Electric	06,10	Sanyo	11
Gold Star	03,04,17	Scott	12
Hitachi	02,03	Sears	02,10,11
J.C.Penny	04,12	Sharp	03,05,18
JVC	09	Sylvania	08,12
KMC	03	Teknika	03,08,14
Magnavox	03,08,12	Toshiba	07
Marantz	04,13	Wards	03,04,12
MGA/Mitsubishi	04,12,13,17	Yox	12
NEC	04,12	Zenith	15

When you set the TV/DVD switch to TV, you can control your TV using the keys below.



By pressing	You can
I/POWER	Turn on or off the TV
TV/VIDEO	Select the input source for the TV
VOL	Adjust the volume of the TV
CH	Change the channel of the TV
Number buttons and ENTER	Select the channel of the TV

Note  
Depending on the TV, you may not be able to control your TV or to use some buttons above.

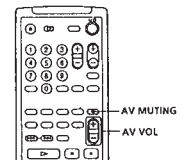
#### Controlling an AV receiver with the remote

- Slide TV/DVD switch to DVD.
- Hold down I/POWER, and enter your AV receiver's manufacturer's code (see the table below) using the number buttons. Then release I/POWER.

Manufacturer	Code number
Sony	91(default), 88, 89
Denon	84, 85, 86
Kenwood	92, 93
Onkyo	81, 82, 83
Pioneer	99
Sunsai	87
Technics	97, 98
Yamaha	94, 95, 96

Code numbers of controllable receivers  
If more than one code number is listed, try entering them one at a time until you find the one that works with your receiver.

You can also change the volume of the sound using AV VOL and AV MUTING.



Note  
You may not be able to control some AV receivers.

### Enjoying the Dolby Digital (AC-3) or DTS Surround Sound

With DVDs which contain DTS or Dolby Digital (AC-3) sound, you can enjoy the surround sound while producing the effect of being in a movie theater or a concert hall, using a digital component with a built-in DTS or Dolby Digital (AC-3) decoder (not supplied). The player outputs the surround sound signals from the DIGITAL OUT OPTICAL and COAXIAL connectors.

For details on items in "INITIAL SETUP 3" in the setup display, see page 38.

#### Hooking up the system

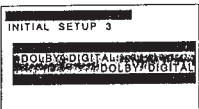
Connect the component via the DIGITAL OUT OPTICAL or COAXIAL connector using an optical or coaxial digital connecting cord (not supplied). You do not need to connect both of these cords. See the figure on the next page.

#### Notes on connection

- Do not connect the power cord to an AC outlet or press the POWER switch before completing all connections.
- Refer to the instructions supplied with the component to be connected.

#### Enjoying the Dolby Digital (AC-3) Surround Sound

In the setup display, set "DIGITAL OUT" to "ON" and then, "DOLBY DIGITAL" to "DOLBY DIGITAL" in "INITIAL SETUP 3." For details on using the setup display, see page 34.

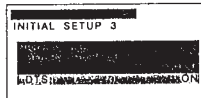


#### Notes

- If you connect the player to an audio component without a built-in Dolby Digital (AC-3) decoder and set "DOLBY DIGITAL" to "D-PCM" in "INITIAL SETUP 3", the output signals via the DIGITAL OUT OPTICAL and COAXIAL connectors are mixed down to stereo when you play Dolby Digital (AC-3) sound tracks.
- If the player is connected to an audio component without a built-in Dolby Digital (AC-3) decoder, do not set "DOLBY DIGITAL" in "INITIAL SETUP 3" to "DOLBY DIGITAL." Otherwise, when you play the Dolby Digital (AC-3) sound track, a loud noise will come out from the speakers, affecting your ears or causing the speakers to be damaged.

### Enjoying the DTS Surround Sound

In the setup display, set "DIGITAL OUT" to "ON" and then, "DTS" to "ON" in "INITIAL SETUP 3." For details on using the setup display, see page 34.



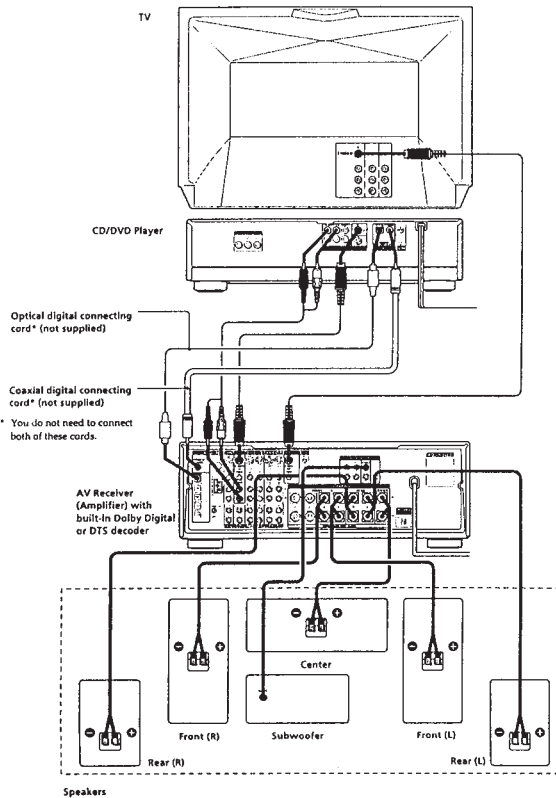
- Do not play the DTS sound tracks without connecting the player to an audio component with a built-in DTS decoder. You cannot hear the DTS sound unless you connect the player to an audio component with a built-in DTS decoder.
- When you play the DTS sound track on a CD, a loud noise will come out from the LINE OUT (AUDIO 1, 2) and PHONES connectors, affecting your ears or causing the speakers or headphones to be damaged.
- When you play the DTS sound track on a DVD, no sounds will come out from the LINE OUT (AUDIO 1, 2) and PHONES connectors.

#### Notes on playing the DTS sound tracks on a CD

- Do not play the DTS sound tracks without connecting the player to an audio component with a built-in DTS decoder. The player output the DTS signal via the DIGITAL OUT OPTICAL and COAXIAL connectors even if "DTS" in "INITIAL SETUP 3" is set to "OFF" in the setup display, affecting your ears or causing the speakers to be damaged.
- The DTS indicator on the front panel does not light up even if the player outputs DTS signal via the DIGITAL OUT OPTICAL and COAXIAL connectors.

#### Notes on playing the DTS sound tracks on a DVD

- No sounds will come out from the LINE OUT (AUDIO 1, 2) and PHONES connectors.
- If the player is connected to an audio component without a built-in DTS decoder, do not set "DTS" in "INITIAL SETUP 3" to "ON" in the setup display. Otherwise, when you play the DTS sound track, a loud noise will come out from the speakers, affecting your ears or causing the speakers to be damaged.
- When you set "DTS" in "INITIAL SETUP 3" to "OFF", no sound will come out from the DIGITAL OUT OPTICAL and COAXIAL connectors even if you play DTS sound tracks on DVDs.
- The DTS indicator on the front panel lights up when you play DTS sound tracks.



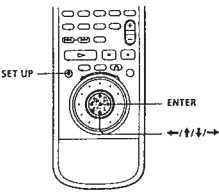
## Settings and Adjustments

### Using the Setup display

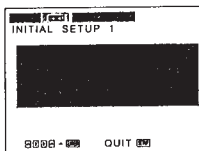
Using the setup display, you can do the initial setup, adjusting the picture and sound quality, setting the various outputs, etc. You can also set a language for the subtitles and the setup display, limit playback by children, etc.

For details on each setup display item, see pages 35 to and 38.

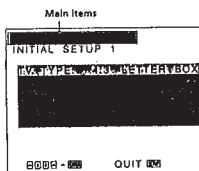
The setup display items are listed in page 48.



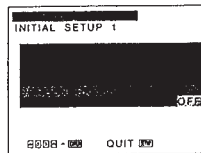
- Press SET UP\* to display the setup display on the TV screen.



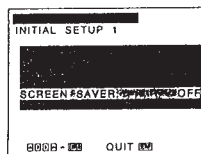
- Select the main item you want using ←/→, and then press ENTER. The selected main item is highlighted.



- Select the item you want using ↑/↓, then press → or ENTER.



- Select the setting you want using ↑/↓, then press ENTER.



To cancel using the setup display on the way Press SET UP.

#### Note

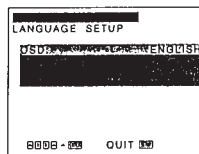
Some setup display items require operations other than selecting the setting. For details on these items, see the relevant pages.

### Setting the Language for Display and Sound (LANGUAGE SETUP)

Select "OSD" after pressing SET UP. "LANGUAGE SETUP" allows you to set various languages for on-screen display or sound. Default settings are underlined.

#### Note

When you select a language that is not recorded on the DVD, one of the recorded languages is automatically selected except for "OSD".



#### OSD (On-Screen Display)

Switches the language for the on-screen display.

- ENGLISH
- FRENCH
- SPANISH

#### DVD MENU

Switches the language for the DVD menu.

- ENGLISH
- FRENCH
- SPANISH
- ITALIAN
- GERMAN
- DUTCH
- PORTUGUESE
- CHINESE
- JAPANESE
- OTHERS→

When you select "OTHERS," select and enter the language code from the list using the number buttons (page 49).

#### AUDIO

Switches the language for the sounds.

- ORIGINAL: the language given the priority in the disc
- ENGLISH
- FRENCH
- SPANISH
- ITALIAN
- GERMAN
- DUTCH
- PORTUGUESE
- CHINESE
- JAPANESE
- OTHERS→

#### AUDIO FOLLOW\*

- ENGLISH
- FRENCH
- SPANISH
- ITALIAN
- GERMAN
- DUTCH
- PORTUGUESE
- CHINESE
- JAPANESE
- OTHERS→

#### When you select "OTHERS,"

select and enter the language code from the list using the number buttons (page 49).

#### SUBTITLE

Switches the language for the subtitles.

- AUDIO FOLLOW\*
- ENGLISH
- FRENCH
- SPANISH
- ITALIAN
- GERMAN
- DUTCH
- PORTUGUESE
- CHINESE
- JAPANESE
- OTHERS→

#### When you select "OTHERS,"

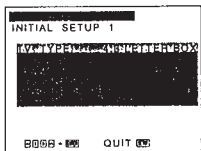
select and enter the language code from the list using the number buttons (page 49).

#### When you select "AUDIO FOLLOW,"

the language for the subtitles change according to the language for the sound.

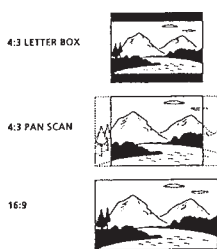
### Settings for Display (INITIAL SETUP 1)

Select "INITIAL SETUP 1" after pressing SET UP. "INITIAL SETUP 1" allows you to set the display according to the playback conditions. Default settings are underlined>.



#### TV TYPE

- Selects the aspect ratio of the TV to be connected.
- 4:3 LETTER BOX**: when you connect a normal TV to the player. Displays the wide picture with bands displayed on the upper and lower portions of the screen.
- 4:3 PAN SCAN**: when you connect a normal TV to the player. Displays the wide picture on the whole screen with a portion automatically cut off.
- 16:9**: when you connect a wide-screen TV to the player



Note  
Depending on the DVD, "4:3 LETTER BOX" may be selected automatically instead of "4:3 PAN SCAN" and vice versa.

#### AUTO PLAY

- Selects the setting of Auto Play when you connect the AC power cord to the AC outlet.
- QEE**: does not start playing with TIMER, DEMO1 or DEMO2.
- TIMER**: starts playing a disc automatically when you connect the AC power cord to the AC outlet. By connecting a timer (not supplied), you can start playing at any time you want.
- DEMO1**: starts playing the demonstration 1 automatically.
- DEMO2**: starts playing the demonstration 2 automatically.

#### DIMMER

- Adjusts the lighting of the front panel display.
- BRIGHT**: makes the front panel display bright.
- DARK**: makes the front panel display dark.
- OFF**: turns off the lighting of the front panel display.

#### BACKGROUND

- Selects the background color of the TV screen in stop mode.
- BLUE**: The background color is blue.
- BLACK**: The background color is black.

#### SCREEN SAVER

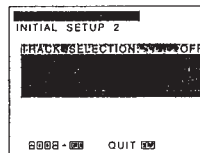
- Turns on and off the screen saver. If you turn on the screen saver, the screen saver image appears when you leave the player or the remote in pause or stop mode for 15 minutes. The screen saver is useful to prevent your display from damage.
- ON**: turns on the screen saver.
- OFF**: turns off the screen saver.

#### PARENTAL CONTROL

- Sets a password and playback limitation level when you play DVDs with playback limitation for children. For details, see page 28.

### Settings for Sound (INITIAL SETUP 2)

Select "INITIAL SETUP 2" after pressing SET UP. "INITIAL SETUP 2" allows you to set the sound according to the playback conditions. Default settings are underlined>.



#### TRACK SELECTION

- Gives the sound track which contains the highest number of the channels priority when you play a DVD on which multiple audio formats are recorded. If multiple audio channels are recorded in PCM, DTS or Dolby Digital (AC-3) format, the higher-numbered channel audio recorded in DTS or Dolby Digital (AC-3) format is played.
- QEE**: No priority given.
- AUTO**: Priority given.

#### Notes

- When you set this item to "AUTO", the language may change depending on the "AUDIO" settings in "LANGUAGE SETUP."
- The "TRACK SELECTION" setting has higher priority than that of "AUDIO" settings in "LANGUAGE SETUP" (page 35).
- If you set "DTS" in "INITIAL SETUP 3" to "OFF", the DTS sound track is not played even if you set this item to "AUTO" and the highest-numbered channel audio is recorded in DTS format.
- If the number of the highest channels of the DTS sound tracks is the same as the one of the Dolby Digital (AC-3) sound tracks, the player selects DTS and Dolby Digital (AC-3) sound tracks, in this order. However, if the highest channel number is 2, the player selects PCM, Dolby Digital (AC-3), and DTS sound tracks, in this order.
- Depending on the DVD, the audio with priority may be predetermined. In this case, you cannot give priority to the DTS or Dolby Digital (AC-3) format by selecting "AUTO."

#### SURROUND

- Switches the mixing down methods when you play a DVD on which the sound is Dolby Digital (AC-3) format is recorded.
- QEE**: when the player is connected to an audio component that conforms to Dolby surround, Dolby Pro Logic surround, etc.
- OFF**: when the player is connected to a normal audio component.

#### AUDIO DRC (Dynamic Range Control)

- Makes the sound clear with the volume turned down at night, etc. when you play a DVD. This affects the output from the LINE OUT (AUDIO L2) connectors when you play the Dolby Digital (AC-3) sound tracks.
- QEE**: Normally select this position.
- ON**: makes the sound clear even if you turned the volume down.

#### Note

When you play DVDs without the AUDIO DRC function, there may be no effect on the sound.

#### AUDIO ATT (attenuation)

- Selects the setting of the output from the LINE OUT (AUDIO L1, 2) connectors according to audio equipment to be connected.
- QEE**: turns off the audio attenuation.
- ON**: reduces the audio output level so that no sound distortion occurs.

#### Note

The setting does not affect the output from the DIGITAL OUT connectors.

#### AUDIO FILTER

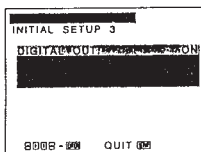
- Selects the type of digital filter to reduce the noise higher frequency than 21.05kHz (fs 44.1kHz), 24kHz (fs 48kHz) or 48kHz (fs 96kHz).
- SHARP**: makes the sound clear and provides smooth sound reproduction. Normally set this position.
- SLOW**: makes the sound warm and deep.

#### Note

Depending on the disc, there may be no effect on the sound.

### Settings for Output Signal Format (INITIAL SETUP 3)

Select "INITIAL SETUP 3" after pressing SET UP. "INITIAL SETUP 3" allows you to control the output signal format from the player via the DIGITAL OUT OPTICAL and COAXIAL connectors. Default settings are underlined.



#### Note

When you set "DIGITAL OUT" to "OFF", you cannot select the other items in "INITIAL SETUP 3."

#### DIGITAL OUT

- Selects output signals via the DIGITAL OUT OPTICAL and COAXIAL connectors.
- QEE**: Normally select this position.
- OFF**: when the player does not output the sound signals via DIGITAL OUT OPTICAL and COAXIAL connectors, if you select this position, the influence of the digital circuit upon the analog one becomes minimum.

#### DOLBY DIGITAL

- Selects output Dolby Digital (AC-3) signals via the DIGITAL OUT OPTICAL and COAXIAL connectors. You cannot select this item when you set "DIGITAL OUT" to "OFF."
- D.PCM** (Downmix PCM): when you play the Dolby Digital (AC-3) sound tracks, the output audio signals are mixed down to 2 channels. By the settings of the item "SURROUND" in "INITIAL SETUP 2", you can select whether the signals conform to Dolby surround, Dolby Pro Logic surround, etc., or not.
- DOLBY DIGITAL**: when the player is connected to an audio component with a built-in Dolby Digital (AC-3) decoder.

#### Note

If the player is connected to an audio component without a built-in Dolby Digital (AC-3) decoder, do not set DOLBY DIGITAL in "INITIAL SETUP 3" to "DOLBY DIGITAL." Otherwise, when you play the Dolby Digital (AC-3) sound track, a loud noise or no sound will come out from the speakers, affecting your ears or causing the speakers to be damaged.

#### DTS

- Selects output DTS signals via the DIGITAL OUT OPTICAL and COAXIAL connectors. You cannot select this item when you set "DIGITAL OUT" to "OFF."
- QEE**: when the player is connected to an audio component without a built-in DTS decoder.
- ON**: when the player is connected to an audio component with a built-in DTS decoder.

- Do not play the DTS sound tracks without connecting the player to an audio component with a built-in DTS decoder. You cannot hear the DTS sound unless you connect the player to an audio component with a built-in DTS decoder.
- When you play the DTS sound track on a CD, a loud noise will come out from the LINE OUT (AUDIO 1, 2) and PHONES connectors, affecting your ears or causing the speakers or headphones to be damaged.
- When you play the DTS sound track on a DVD, no sounds will come out from the LINE OUT (AUDIO 1, 2) and PHONES connectors.

#### Notes on playing the DTS sound tracks on a CD

- Do not play the DTS sound tracks without connecting the player to an audio component with a built-in DTS decoder. The player output the DTS signal via the DIGITAL OUT OPTICAL and COAXIAL connectors even if "DTS" in "INITIAL SETUP 3" is set to "OFF" in the setup display, affecting your ears or causing the speakers to be damaged.
- The DTS indicator on the front panel does not light up even if the player outputs DTS signal via the DIGITAL OUT OPTICAL and COAXIAL connectors.

#### Notes on playing the DTS sound tracks on a DVD

- No sounds will come out from the LINE OUT (AUDIO 1, 2) and PHONES connectors.
- If the player is connected to an audio component without a built-in DTS decoder, do not set "DTS" in "INITIAL SETUP 3" to "ON" in the setup display. Otherwise, when you play the DTS sound track, a loud noise will come out from the speakers, affecting your ears or causing the speakers to be damaged.
- When you set "DTS" in "INITIAL SETUP 3" to "OFF", no sound will come out from the DIGITAL OUT OPTICAL and COAXIAL connectors even if you play DTS sound tracks on DVDs.
- The DTS indicator on the front panel lights up when you play DTS sound tracks.

### Precautions

#### On safety

- Caution - The use of optical instruments with this product will increase eye hazard.
- Should any solid object or liquid fall into the cabinet, unplug the player and have it checked by qualified personnel before operating it any further.

#### On power sources

- The player is not disconnected from the AC power source (mains) as long as it is connected to the wall outlet, even if the player itself has been turned off.
- If you are not going to use the player for a long time, be sure to disconnect the player from the wall outlet. To disconnect the AC power cord (mains lead), grasp the plug itself, never pull the cord.
- Should the AC power cord (mains lead) need to be changed, have it done at a qualified service shop only.

#### On placement

- Place the player in a location with adequate ventilation to prevent heat build-up in the player.
- Do not place the player on a soft surface such as a rug that might block the ventilation holes on the bottom.
- Do not place the player in a location near heat sources, or in a place subject to direct sunlight, excessive dust or mechanical shock.

#### On operation

- If the player is brought directly from a cold to a warm location, or is placed in a very damp room, moisture may condense on the lenses inside the player. Should this occur, the player may not operate properly. In this case, remove the disc and leave the player turned on for about half an hour until the moisture evaporates.

#### On adjusting volume

- Do not turn up the volume while listening to a portion with very low level inputs or no audio signals. If you do, the speakers may be damaged when a peak level portion is played.

#### On cleaning

- Clean the cabinet, panel and controls with a soft cloth slightly moistened with a mild detergent solution. Do not use any type of abrasive pad, scouring powder or solvent such as alcohol or benzine.

If you have any questions or problems concerning your player, please consult your nearest Sony dealer.

#### IMPORTANT NOTICE

Caution: The enclosed DVD Player is capable of holding a still video image or Setup display image on your television screen indefinitely. If you leave the still video image or Setup display image displayed on your TV for an extended period of time you risk permanent damage to your television screen. Projection televisions are very susceptible.

### Notes on Discs

#### On handling discs

- To keep the disc clean, handle the disc by its edge. Do not touch the surface.
- Do not stick paper or tape on the disc. If there is glue (or a similar substance) on the disc, remove the glue completely before using the disc.



- Do not expose the disc to direct sunlight or heat sources such as hot air ducts, or leave it in a car parked in direct sunlight as there can be considerable rise in temperature inside the car.
- After playing, store the disc in its case.

#### On cleaning

- Before playing, clean the disc with a cleaning cloth. Wipe the disc from the center out.



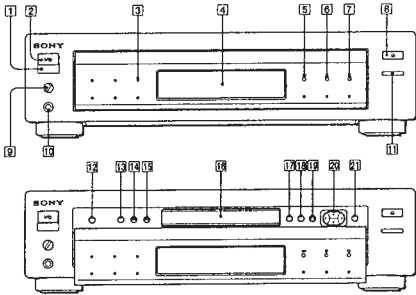
- Do not use solvents such as benzene, thinner, commercially available cleaners or anti-static spray intended for vinyl LPs.

**Additional Information**

**Index to Parts and Controls**

Refer to the pages indicated in parentheses for details.

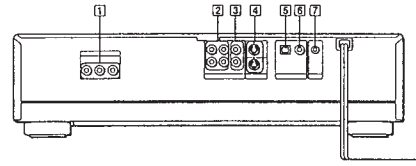
**Front Panel**



- 1 ■ (remote sensor) (6)  
Accepts the remote control signals.
- 2 I/O switch and indicator (10, 14, 30)  
Turns on and off the power of the player.
- 3 DTS indicator (10, 14, 32)  
Indicates DTS sound tracks on a DVD.
- 4 Front Panel Display (20)  
Indicates the playing time, etc.
- 5 >▶ PLAY button (10, 14, 25)  
Plays a disc.
- 6 ⏸ PAUSE button (11, 15)  
Pauses playing a disc.
- 7 ⏹ STOP button (11, 15, 25)  
Stops playing a disc.
- 8 ⏪ OPEN/CLOSE button (10, 14)  
Opens or closes the disc tray.
- 9 PHONE LEVEL control (10, 14)  
Adjusts the headphone volume.
- 10 PHONES connector (10, 14)  
Connect the headphones to this connector.
- 11 UP/DOWN button (10, 14)  
Moves the front panel up and down.
- 12 SET UP button (34)  
Displays the setup display on the TV screen to set or adjust the items.
- 13 DNR button (26)  
Reduces the picture noise.
- 14 ⏮ PREVIOUS button (11, 15)  
Press to go back to the preceding chapter or track.
- 15 ⏭ NEXT button (11, 15)  
Press to go to the next chapter or track.
- 16 Disc tray (10, 14)  
Place a disc on the tray.
- 17 TITLE button (13)  
Displays the title menu on the TV screen.
- 18 DVD MENU button (13)  
Displays the DVD menu on the TV screen.
- 19 ↶ RETURN button (17)  
Press to return to the preceding selection screen, etc.
- 20 ⏪/⏩ buttons  
Selects the items or settings.
- 21 ENTER button  
Executes the items or settings.

**Additional Information**

**Rear Panel**



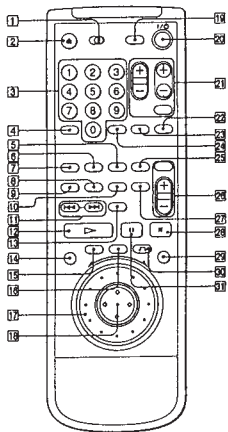
- 1 COMPONENT VIDEO OUT connectors (7)  
Connects to the monitor or projector with component video input connectors (Y, Pb/B-Y, Pr/R-Y) that conform to output signals from the player.
- 2 LINE OUT (AUDIO 1, 2) connectors (7)  
Connects to the audio input connector on the TV or receiver (amplifier).
- 3 LINE OUT (VIDEO 1, 2) connectors (7)  
Connects to the video input connector on the TV or monitor.
- 4 S VIDEO OUT 1, 2 connectors (7)  
Connects to the S video input connector on the TV or VCR.
- 5 DIGITAL OUT (OPTICAL) connector (8, 32)  
Connects to an audio component using the optical digital connecting cord.
- 6 DIGITAL OUT (COAXIAL) connector (8, 32)  
Connects to an audio component using the coaxial digital connection cord.
- 7 S-LINK connector (7)  
Connects to the S-link connector on an external component.

45<sup>us</sup>

46<sup>us</sup>

**Additional Information**

**Remote**



- 1 TV/DVD switch (30, 31)  
Selects to control the player or the TV with the remote.
- 2 ⏪ OPEN/CLOSE button (11, 15)  
Opens or closes the disc tray.
- 3 Number buttons (11, 15)  
Selects the items or settings.
- 4 SEARCH MODE button (11, 15)  
Press to select the unit for search (track, index, etc.)
- 5 REPEAT button (22)  
Press to execute the repeat play.
- 6 PROGRAM button (24)  
Press to execute the program play.
- 7 SHUFFLE button (23)  
Press to execute the shuffle play.
- 8 ANGLE CHANGE button (27)  
Changes the angles when playing a DVD.
- 9 AUDIO CHANGE button (26)  
Changes the sound while playing a DVD or VIDEO CD.
- 10 SUBTITLE CHANGE button (27)  
Changes the subtitles when playing a DVD.
- 11 ⏮/⏭/⏩ PREVIOUS/NEXT buttons (11, 15)  
Press to go to the next chapter or track or to go back to the preceding chapter or track.
- 12 >▶ PLAY button (10, 14)  
Plays a disc.
- 13 TIME button (18, 20)  
Displays the playing time of the disc, etc., on the front panel display.
- 14 SET UP button (34)  
Displays the setup display on the TV screen to set or adjust the items.
- 15 TITLE button (13)  
Displays the title menu on the TV screen.
- 16 DVD MENU button (13)  
Displays the DVD menu on the TV screen.
- 17 Click shuttle (12, 16)  
Changes the playback speed.
- 18 ⏪/⏩/ENTER button  
Selects and executes the items or settings.
- 19 DISPLAY button (18)  
Displays the current playing status on the TV screen.
- 20 I/O button (10, 14, 30)  
Turns on and off the power of the player.
- 21 TV operation buttons (31)  
Controls TVs.
- 22 DNR button (26)  
Reduces the picture noise.
- 23 CLEAR button (22, 23, 24)  
Press to return to the continuous play etc.
- 24 ENTER button  
Executes the items or settings.
- 25 A→B button (23)  
Press to execute the A→B repeat play.
- 26 Receiver operation buttons (31)  
Controls AV receivers.
- 27 SUBTITLE ON/OFF button (27)  
Turns the subtitles on and off when playing a DVD.
- 28 ■ STOP button (11, 15, 25)  
Stops playing a disc.
- 29 JOG button / Indicator (12, 16)  
Press to play a disc frame by frame.
- 30 ↶ RETURN button (17)  
Press to return to the preceding selection screen, etc.
- 31 ⏸ PAUSE button (11, 15)  
Pauses playing a disc.

47<sup>us</sup>

**Additional Information**

**Language Code List**

For details, see page 35.

The language spellings conform to the ISO 639: 1988 (E/F) standard.

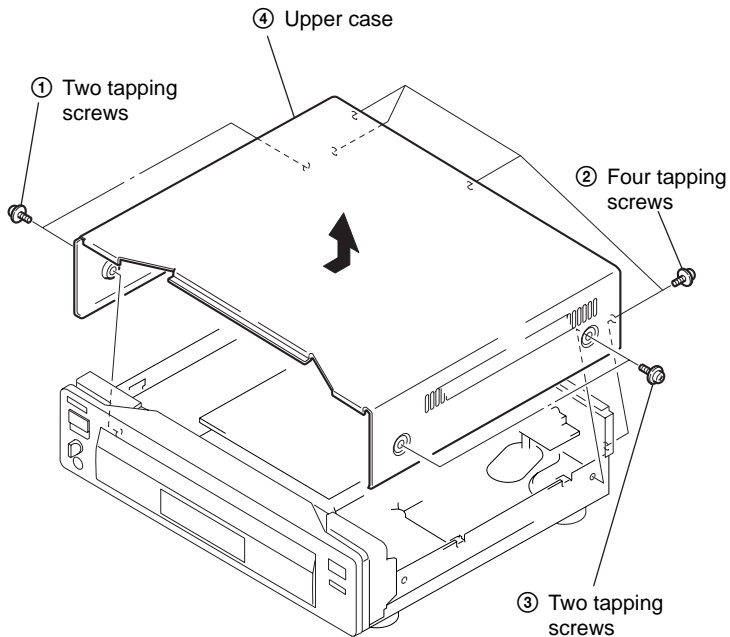
Code	Language	Code	Language	Code	Language	Code	Language
1027	Afar	1186	Scots Gaelic	1350	Malayalam	1513	Siswani
1028	Abkhazian	1194	Galician	1352	Mongolian	1514	Sesotho
1032	Afrikaans	1196	Guarani	1353	Moldavian	1515	Sundanese
1039	Amharic	1203	Gujarati	1356	Marathi	1516	Swedish
1044	Arabic	1209	Hausa	1357	Malay	1517	Swahili
1045	Assamese	1217	Hindi	1358	Maltese	1521	Tamil
1051	Aymara	1226	Croatian	1363	Burmese	1525	Telugu
1052	Azerbaijani	1229	Hungarian	1365	Nauru	1527	Tajik
1053	Bashkir	1233	Armenian	1369	Nepali	1532	Tagalog
1057	Byelorussian	1235	Interlingua	1376	Dutch	1529	Tigrinya
1059	Bulgarian	1239	Interlingue	1379	Norwegian	1531	Turkmen
1060	Bihari	1245	Inupiak	1393	Occitan	1532	Urdu
1061	Bislama	1248	Indonesian	1403	(Afan) Oromo	1534	Setswana
1066	Bengali; Bangla	1253	Icelandic	1408	Oriya	1535	Tonga
1067	Tibetan	1254	Italian	1417	Urjubi	1538	Turkish
1070	Breton	1257	Hebrew	1428	Polish	1539	Tsonga
1079	Catalan	1261	Japanese	1435	Pashto; Pushto	1540	Tatar
1093	Corsican	1269	Yiddish	1436	Portuguese	1543	Twi
1097	Czech	1283	Javanese	1463	Quechua	1557	Ukrainian
1103	Welsh	1287	Georgian	1481	Rhaeto-Romance	1564	Urdu
1105	Danish	1297	Kazakh	1482	Kinundi	1572	Uzbek
1109	German	1298	Greenlandic	1483	Romanian	1581	Vietnamese
1130	Bhutani	1299	Cambodian	1489	Russian	1587	Volapuk
1142	Greek	1300	Kannula	1491	Kinyarwanda	1613	Wolof
1144	English	1301	Korean	1495	Sanskrit	1632	Xhosa
1145	Esperanto	1305	Kashmiri	1498	Sindhi	1665	Yoruba
1149	Spanish	1307	Kurdish	1501	Sango	1684	Chinese
1150	Estonian	1311	Kirghiz	1502	Serbo-Croatian	1697	Zulu
1151	Basque	1313	Latin	1503	Singhalese	1703	Not specified
1157	Persian	1326	Lingala	1505	Slovak		
1165	Finnish	1327	Laotian	1506	Slovenian		
1166	Fiji	1332	Lithuanian	1507	Samoan		
1171	Farose	1334	Latvian; Lettish	1508	Shona		
1174	French	1345	Malagasy	1509	Somali		
1181	Frisian	1347	Maori	1511	Albanian		
1183	Irish	1349	Macedonian	1512	Serbian		

49<sup>us</sup>

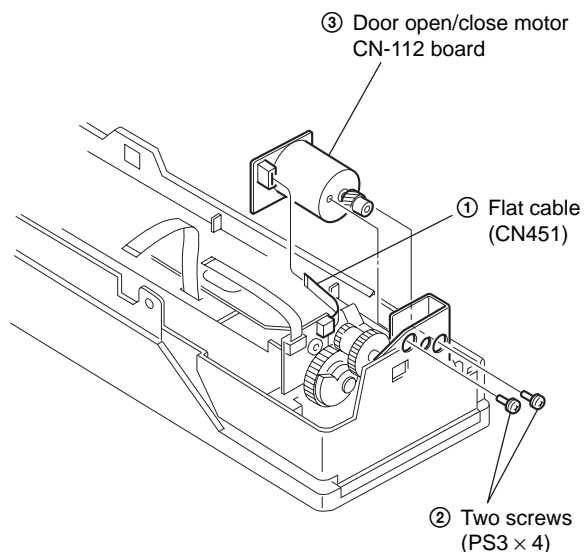
## SECTION 2 DISASSEMBLY

**Note:** Follow the disassembly procedure in the numerical order given.

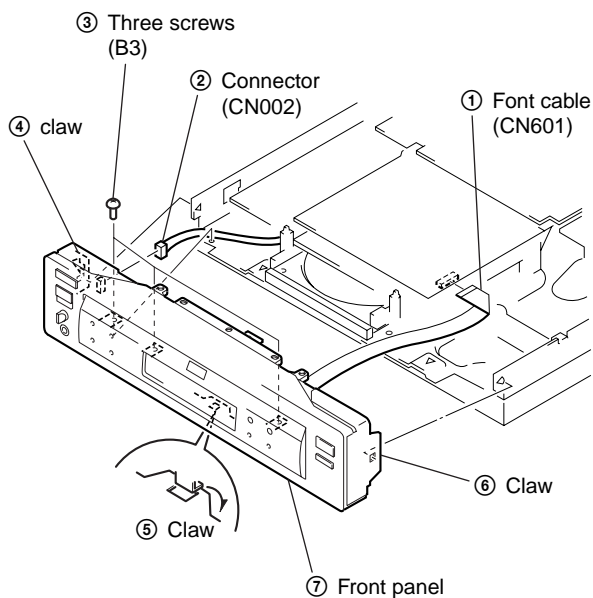
### 2-1. UPPER CASE REMOVAL



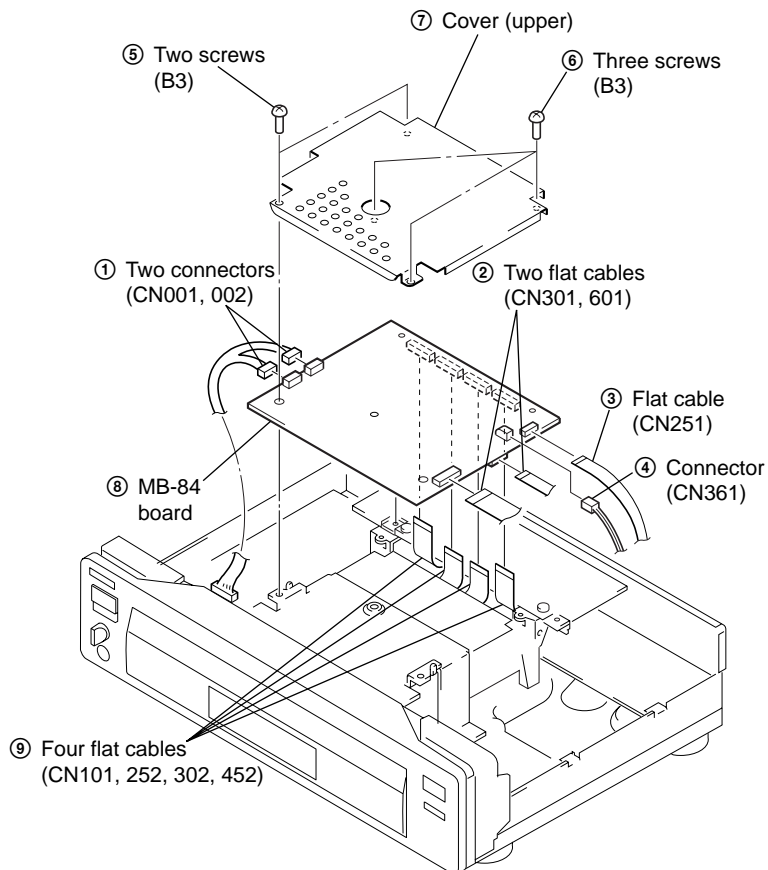
### 2-3. DOOR OPEN/CLOSE MOTOR REMOVAL



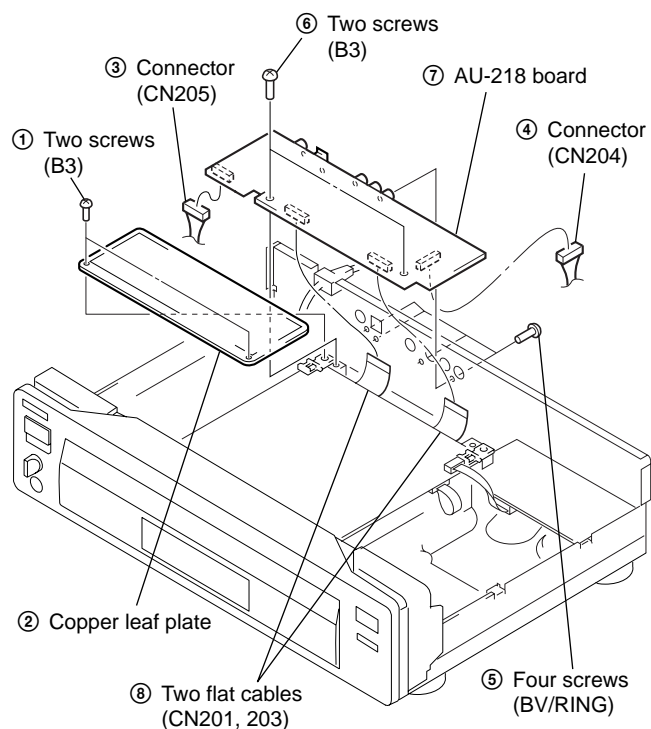
### 2-2. FRONT PANEL REMOVAL



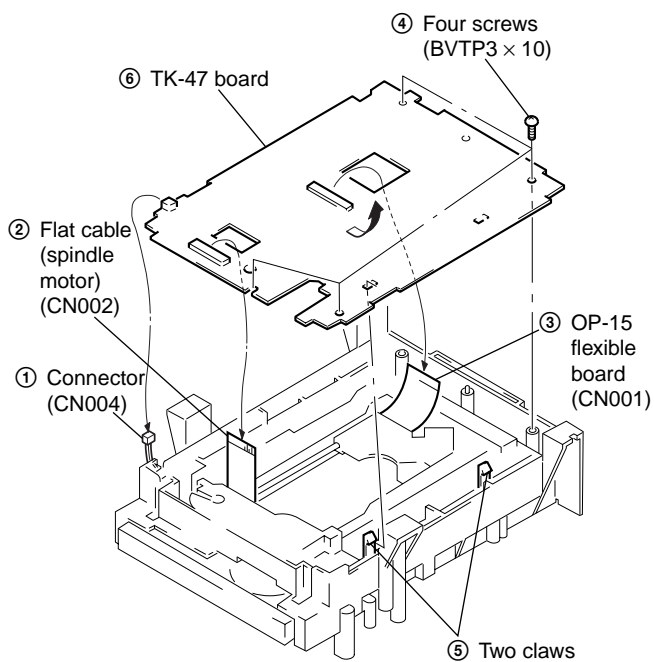
### 2-4. MB-84 BOARD REMOVAL



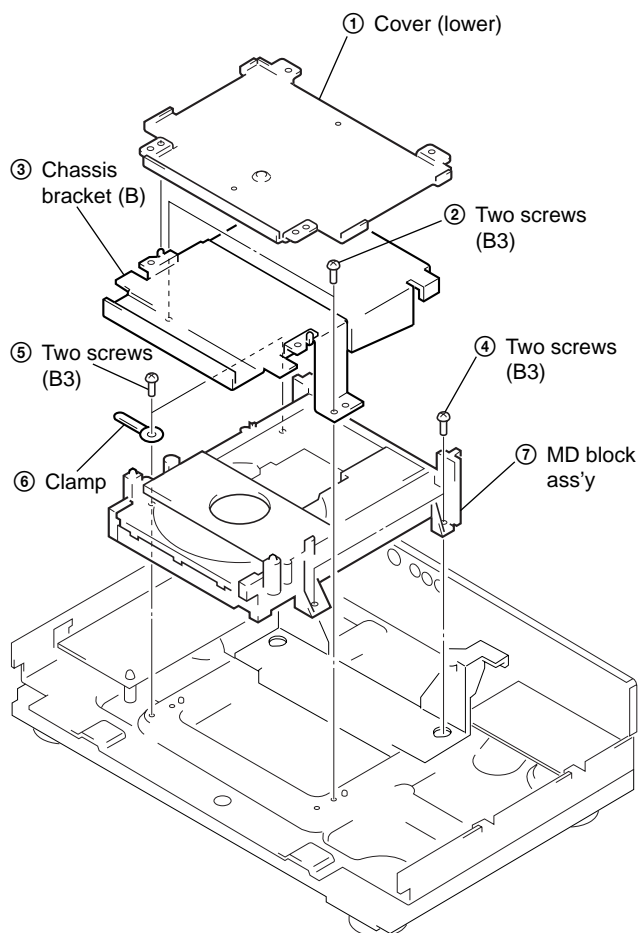
## 2-5. AU-218 BOARD REMOVAL



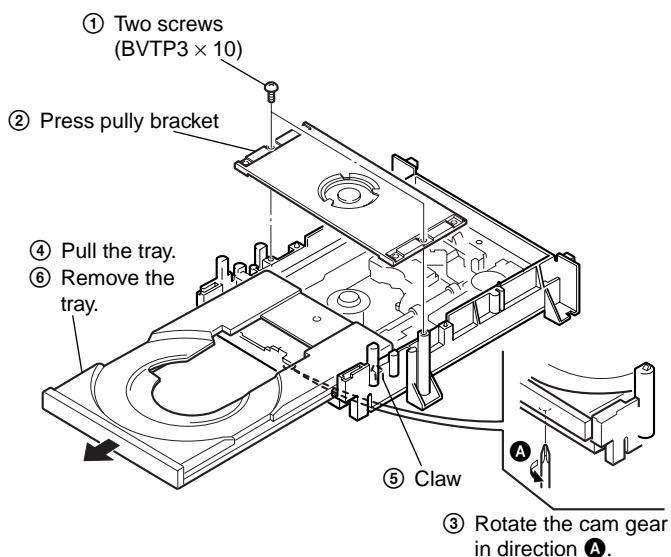
## 2-7. TK-47 BOARD REMOVAL



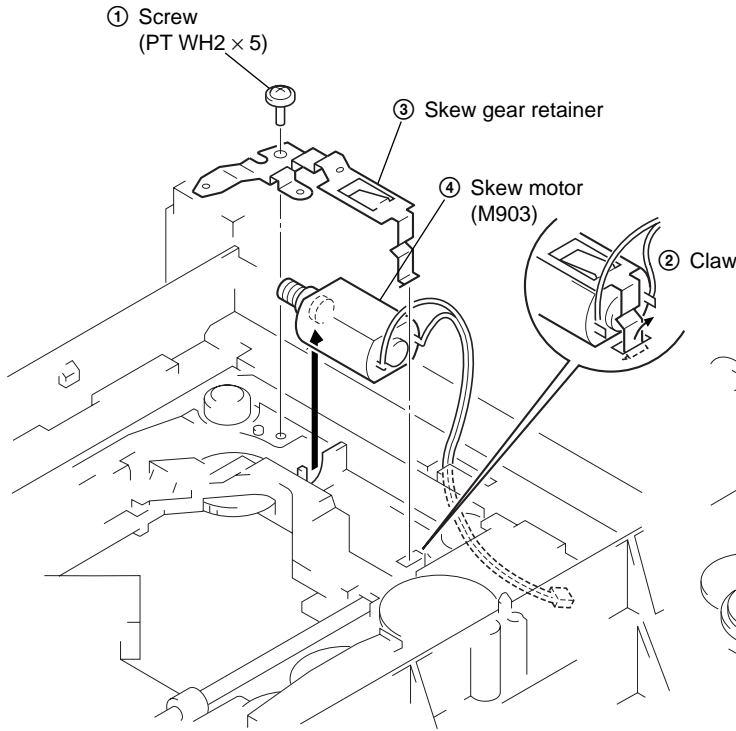
## 2-6. MD BLOCK ASS'Y REMOVAL



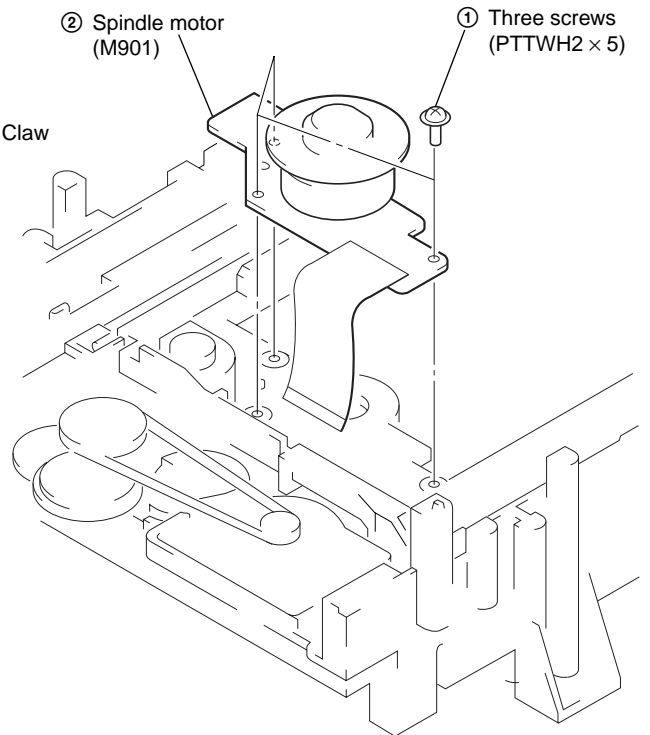
## 2-8. TRAY REMOVAL



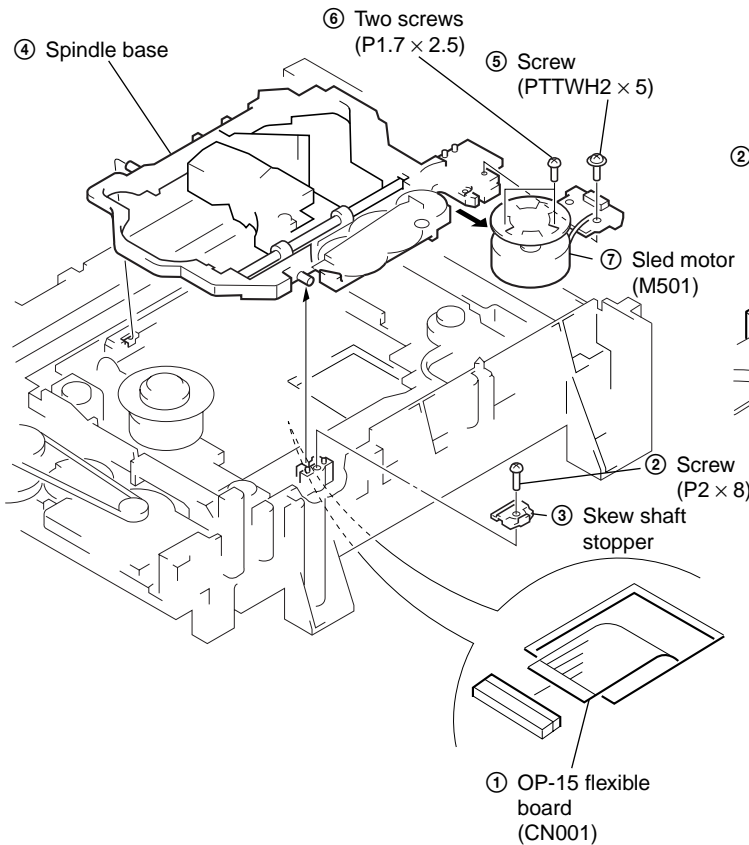
### 2-9. SKEW MOTOR (M903) REMOVAL



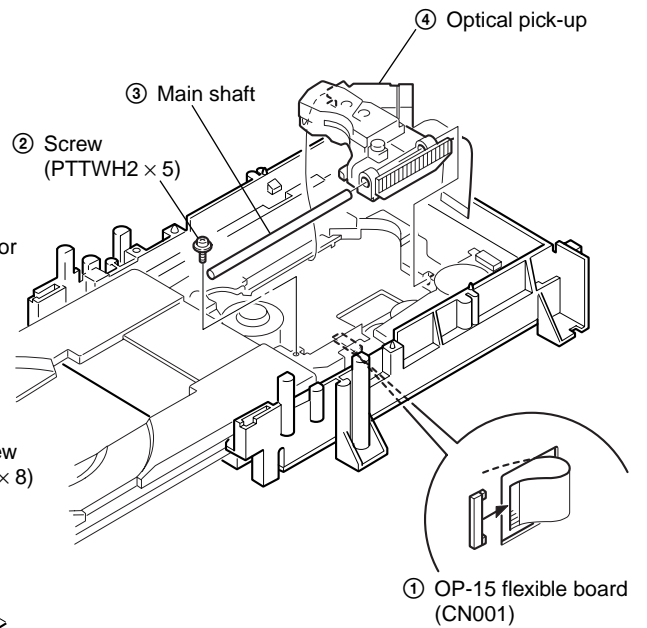
### 2-11. SPINDLE MOTOR (M901) REMOVAL



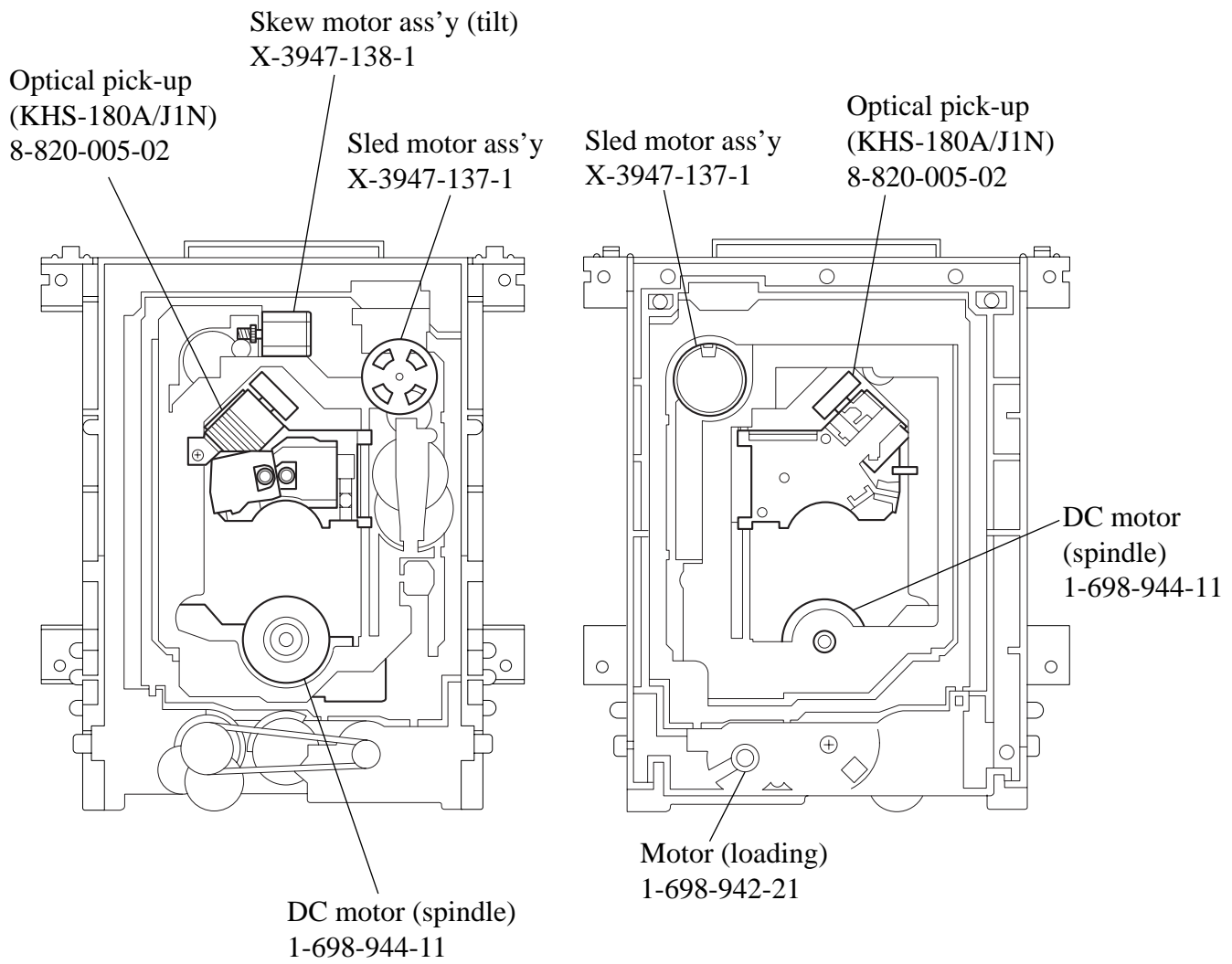
### 2-10. SLED MOTOR (M501) REMOVAL



### 2-12. OPTICAL PICK-UP REMOVAL

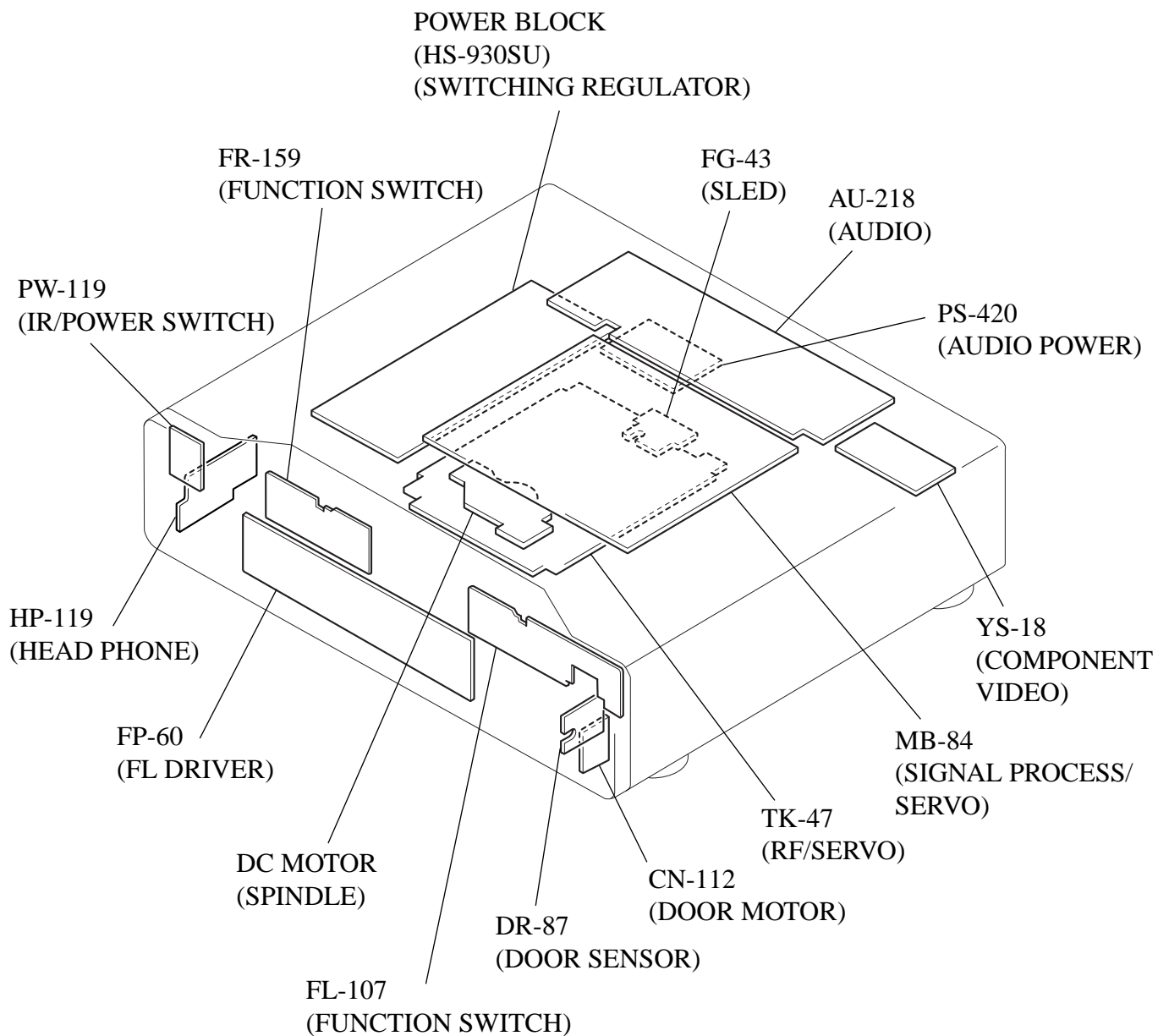


## 2-13. INTERNAL VIEWS



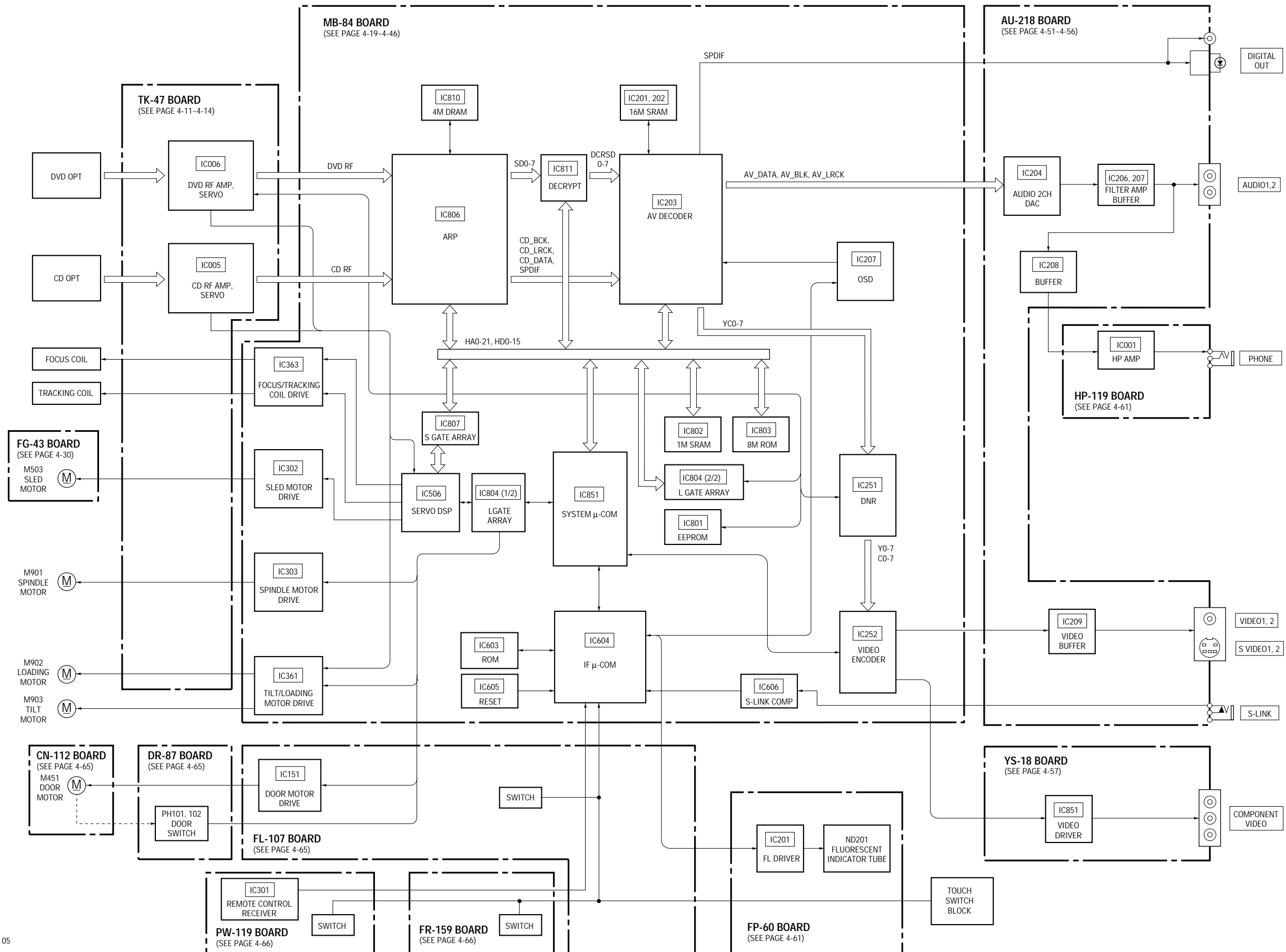


**2-14. CIRCUIT BOARDS LOCATION**

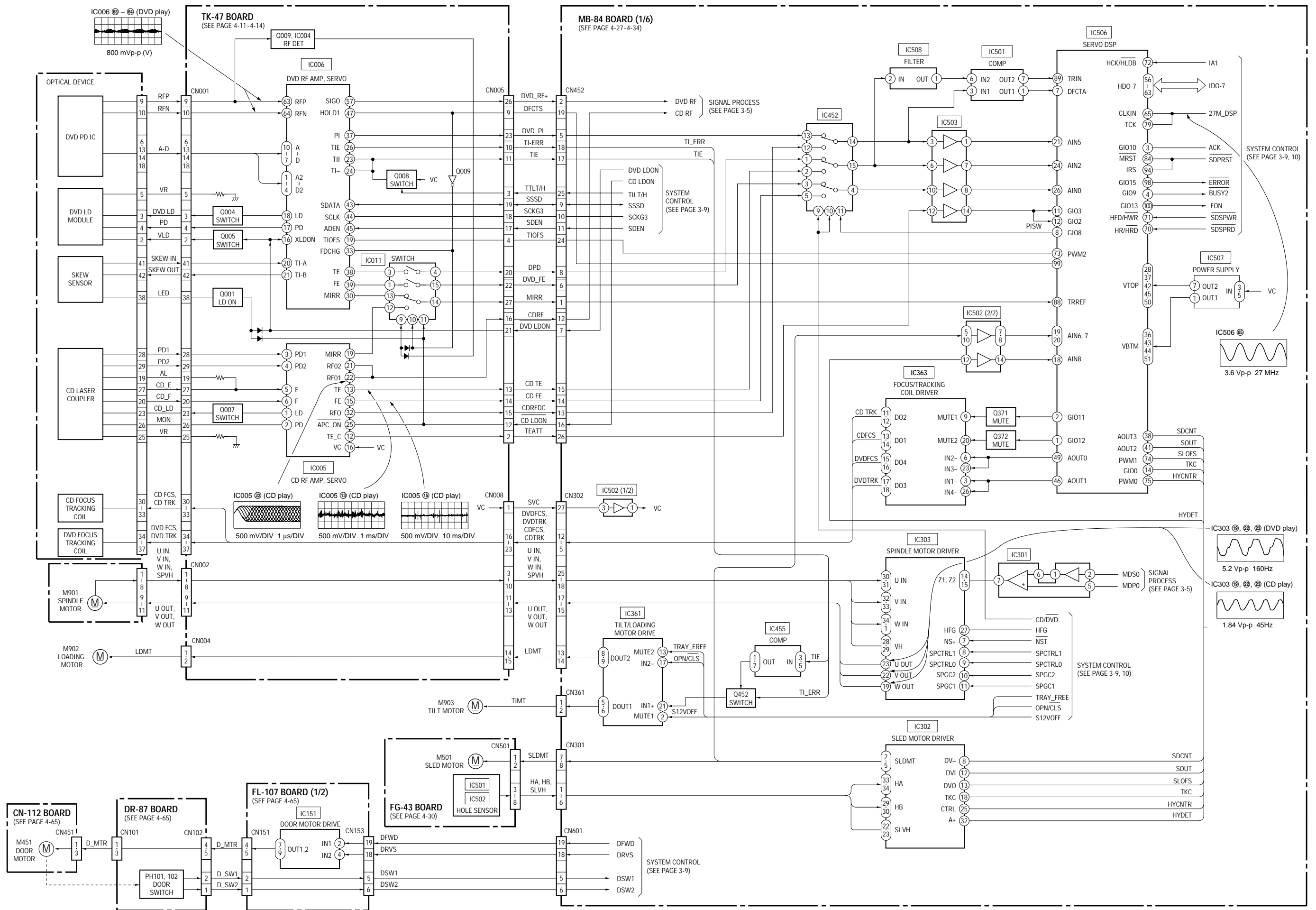


### SECTION 3 BLOCK DIAGRAMS

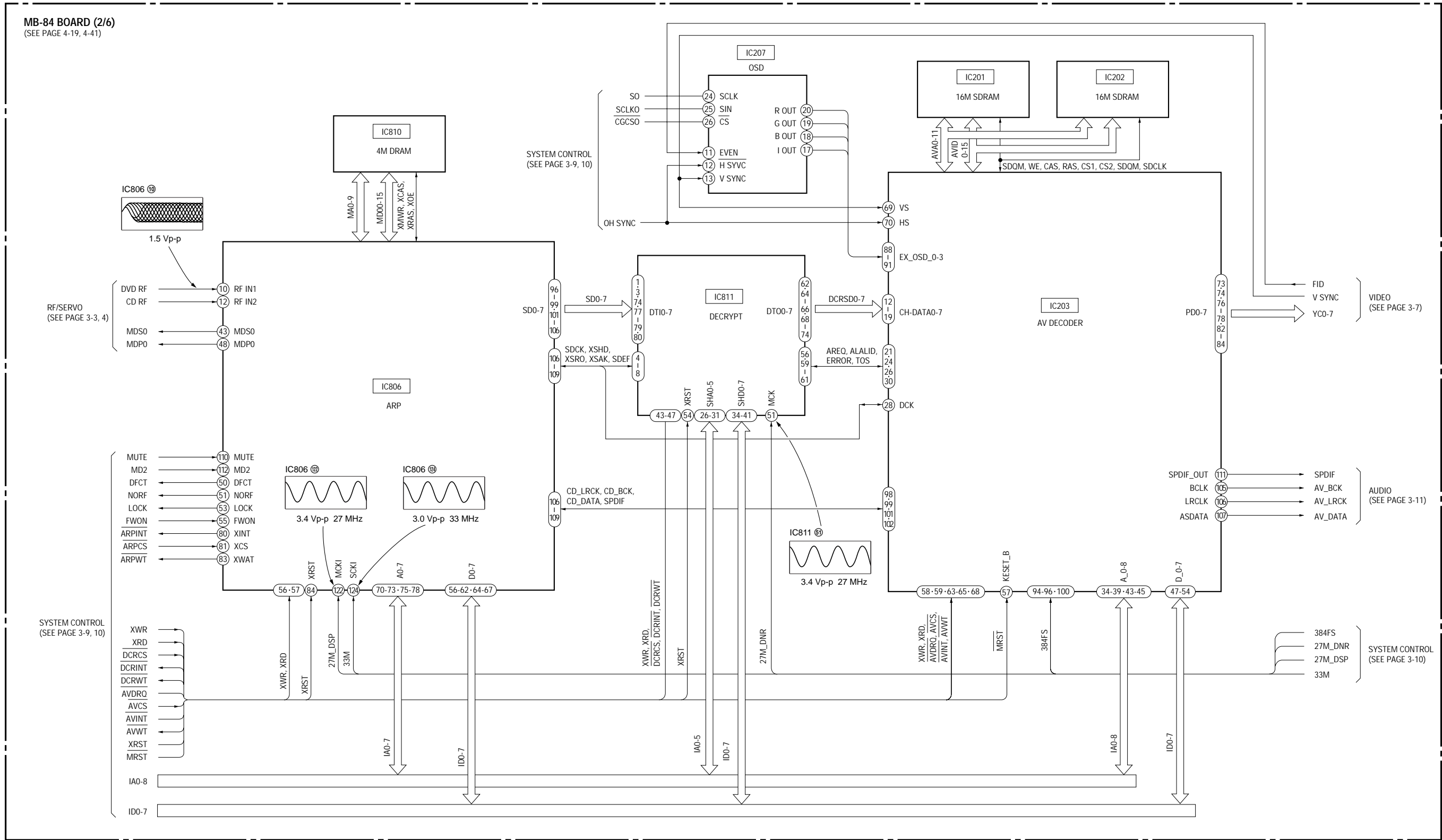
#### 3-1. OVERALL BLOCK DIAGRAM



3-2. RF/SERVO BLOCK DIAGRAM

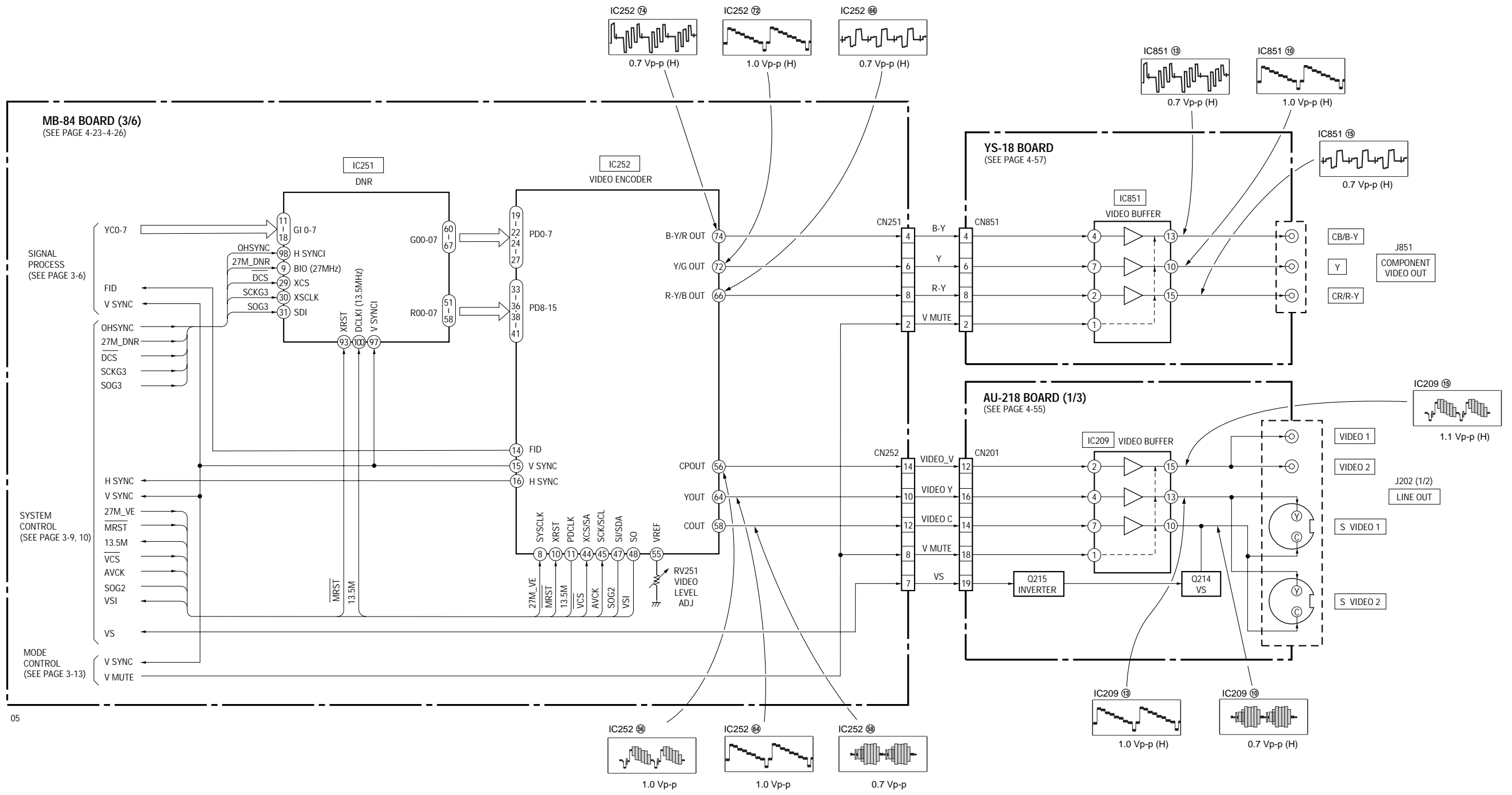


3-3. SIGNAL PROCESS BLOCK DIAGRAM



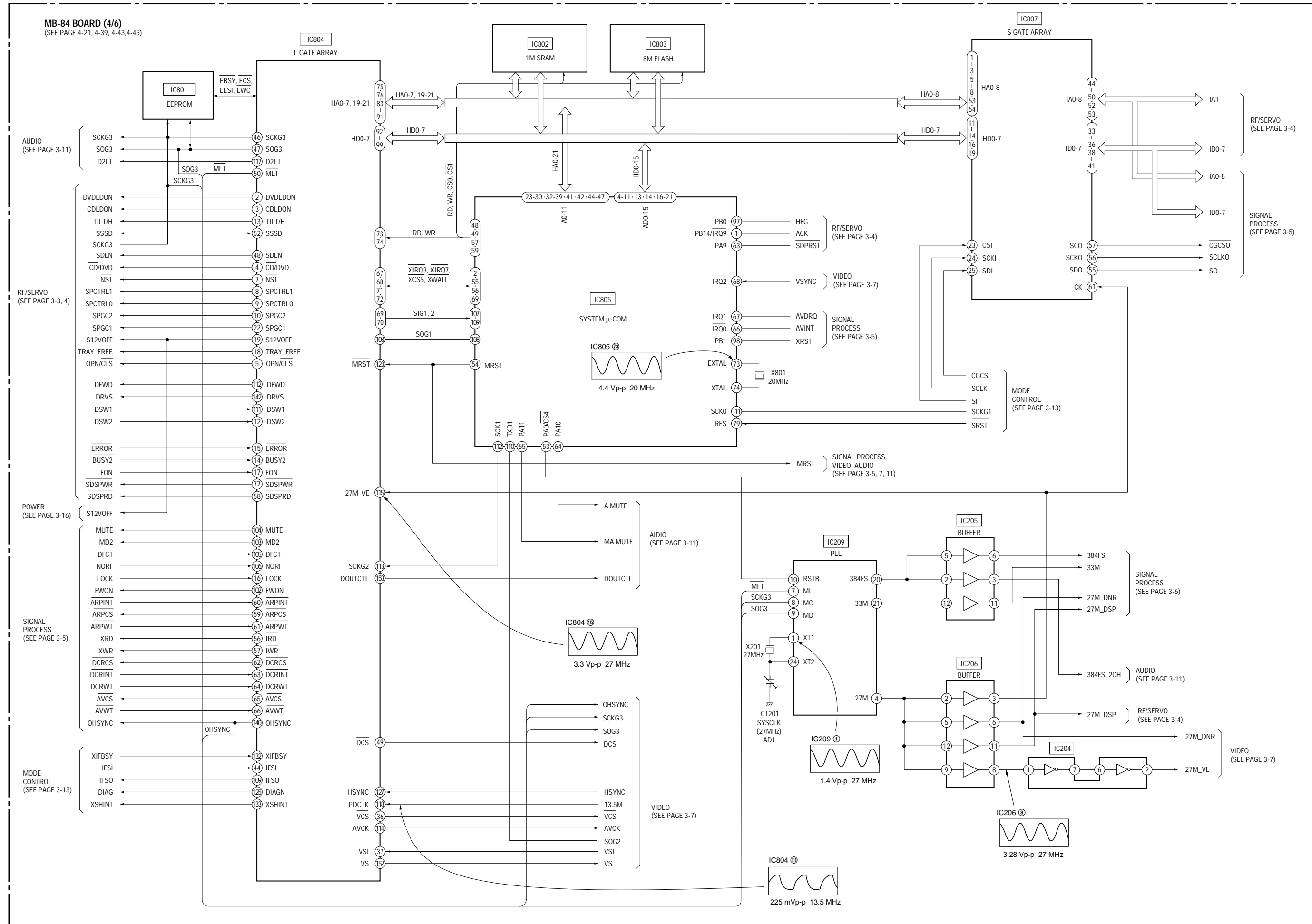
05

3-4. VIDEO BLOCK DIAGRAM

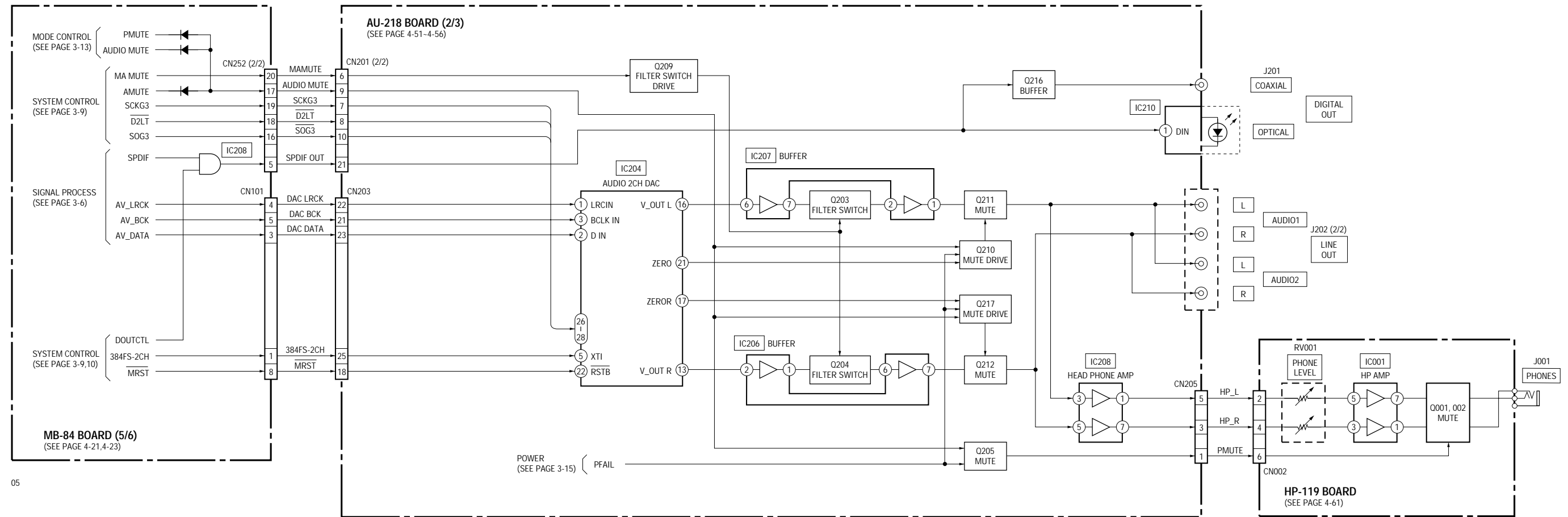


05

3-5. SYSTEM CONTROL BLOCK DIAGRAM

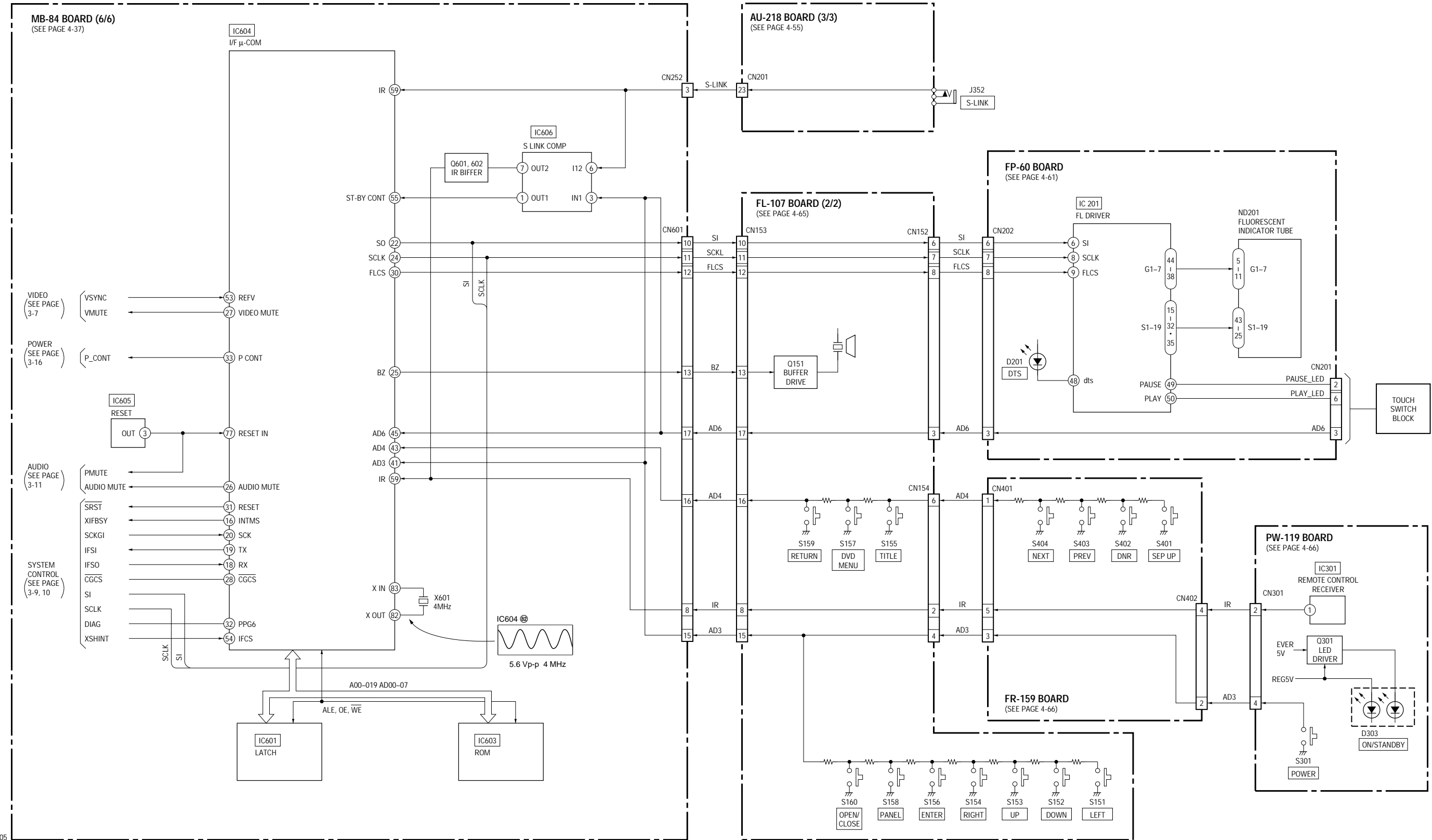


3-6. AUDIO BLOCK DIAGRAM



05

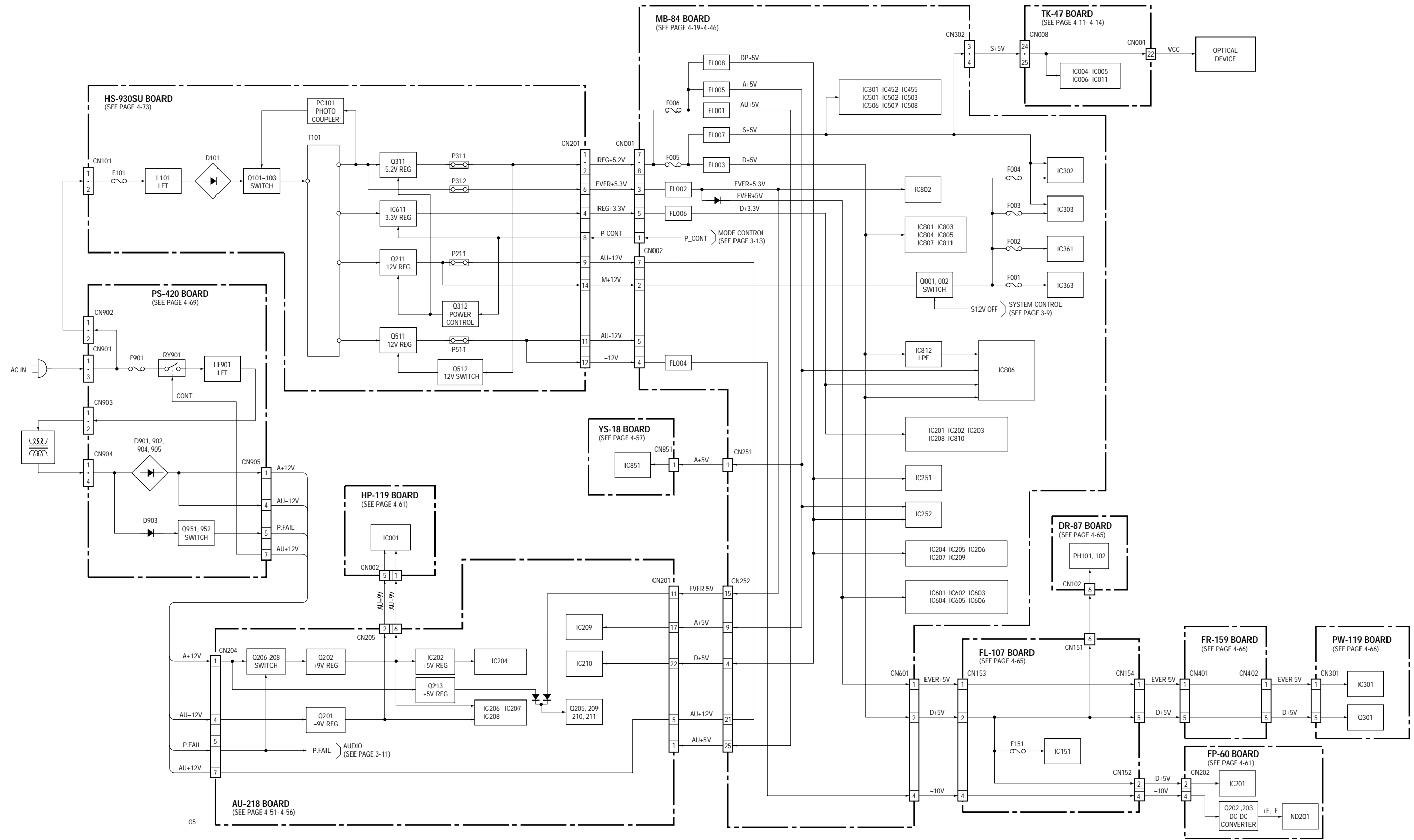
3-7. MODE CONTROL BLOCK DIAGRAM



05



3-8. POWER BLOCK DIAGRAM








05

## SECTION 4 PRINTED WIRING BOARDS AND SCHEMATIC DIAGRAMS








**THIS NOTE IS COMMON FOR PRINTED WIRING BOARDS AND SCHEMATIC DIAGRAMS.  
(In addition to this, the necessary note is printed in each block.)**




**For printed wiring boards:**

-  : indicates a lead wire mounted on the component side.
  -  : indicates a lead wire mounted on the printed side.
  -  : Through hole.
  -  : Parts mounted on the conductor side.
  -  : Pattern from the side which enables seeing.
- (The other layers' patterns are not indicated.)

**Caution:**  
 Pattern face side: Parts on the pattern face side seen from the pattern face are indicated.  
 (Side B)  
 Parts face side: Parts on the parts face side seen from the parts face are indicated.  
 (Side A)

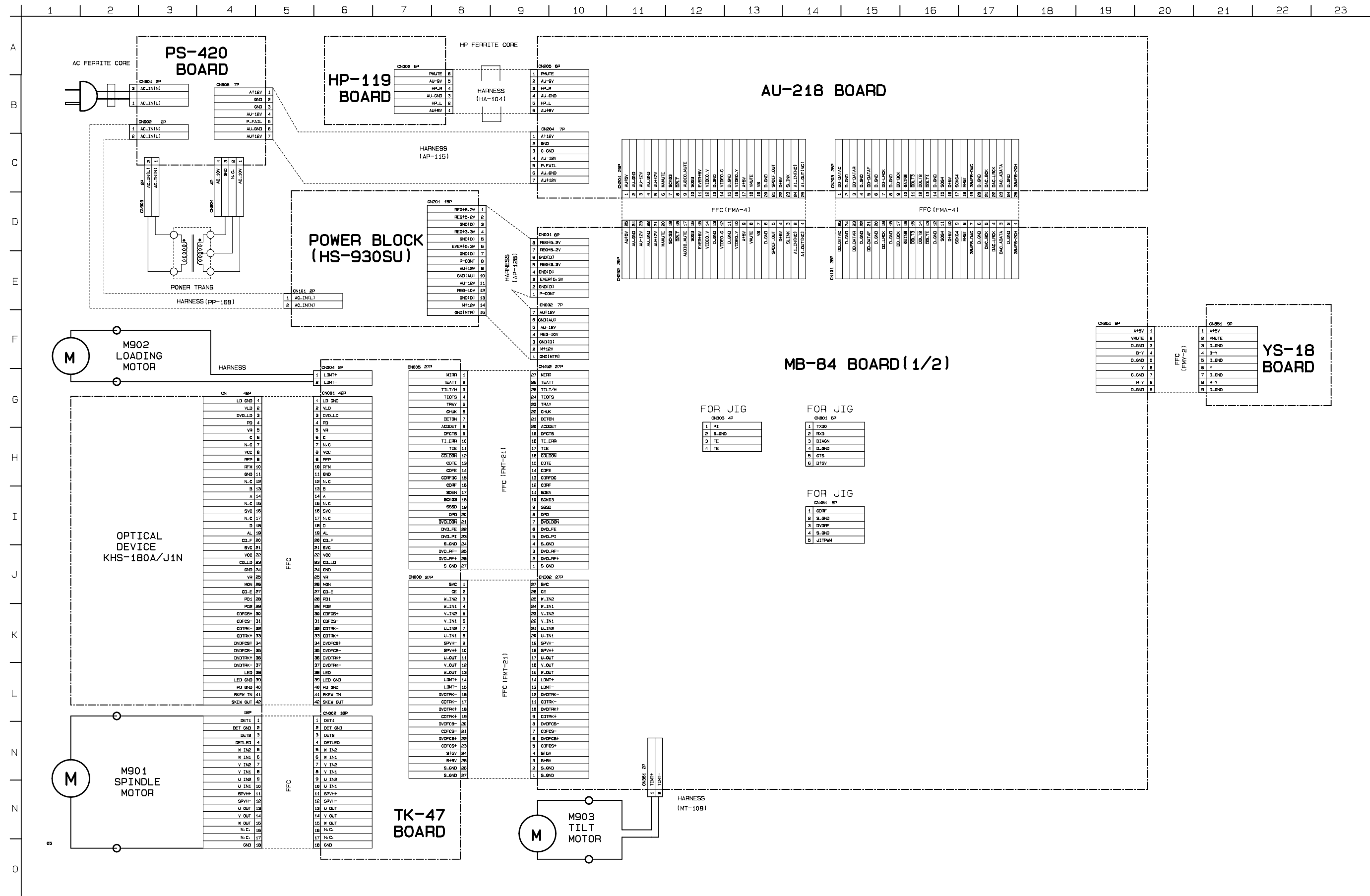
**For schematic Diagram:**

- Caution when replacing chip parts.  
 New parts must be attached after removal of chip.  
 Be careful not to heat the minus side of tantalum capacitor, because it is damaged by the heat.
- All resistors are in ohms,  $\frac{1}{4}$  W (Chip resistors :  $\frac{1}{10}$  W) unless otherwise specified.  
 k $\Omega$  : 1000 $\Omega$ , MW : 1000k $\Omega$ .
- All capacitors are in  $\mu$ F unless otherwise noted. pF :  $\mu$  $\mu$ F  
 50V or less are not indicated except for electrolytics and tantalums.
- All variable and adjustable resistors have characteristic curve B, unless otherwise noted.
-  : nonflammable resistor.
-  : fusible resistor.
-  : panel designation.
-  : internal component.
-  : adjustment for repair.
-  : B+ Line.
-  : B- Line.
- Circled numbers refer to waveforms.
- Voltages are dc between measurement point.
- Readings are taken with a color-bar signals on DVD reference disc and when playing CD reference disc.
- Readings are taken with a digital multimeter (DC 10MW).
- Voltage variations may be noted due to normal production tolerances.

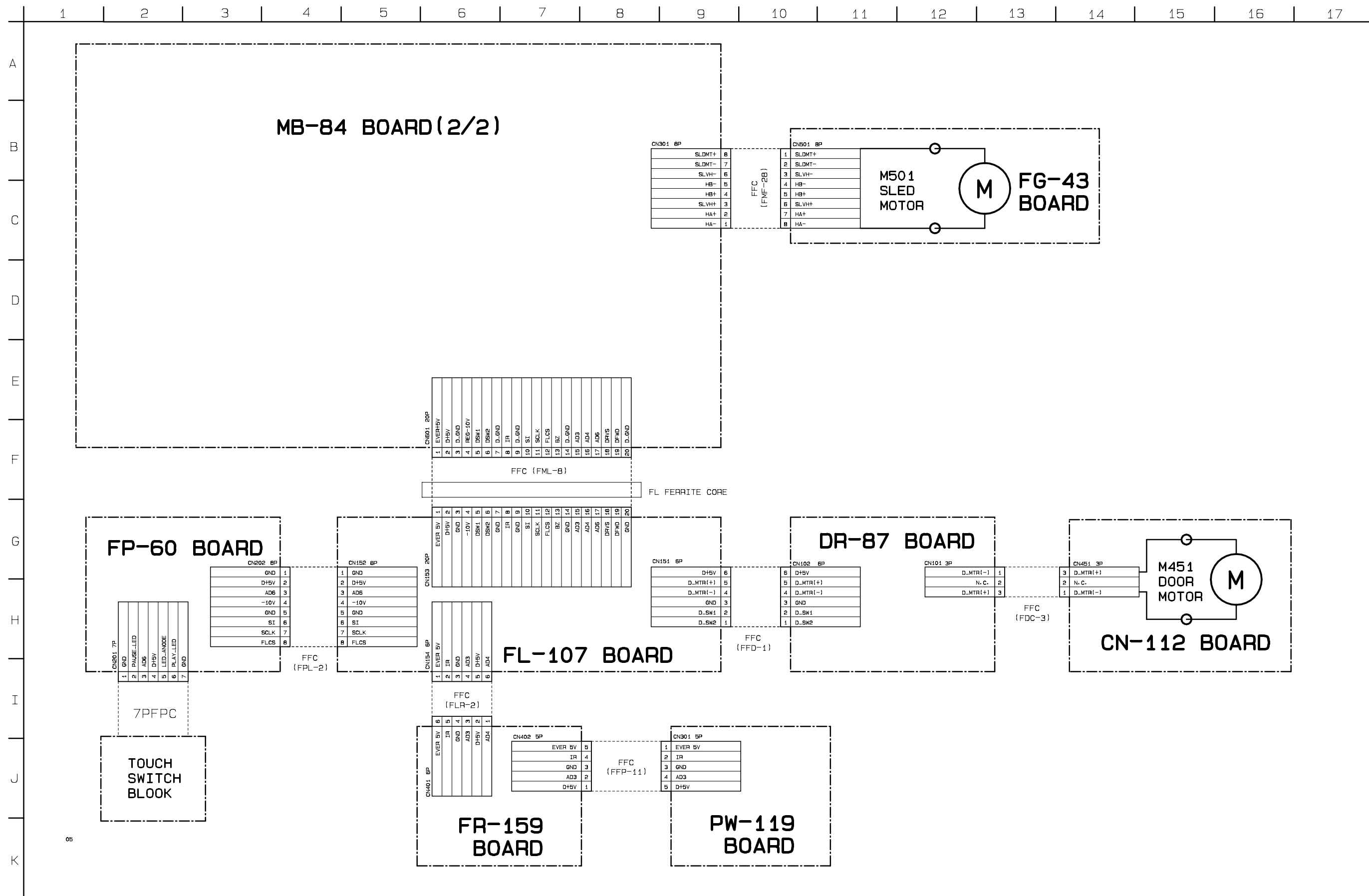
<p><b>Note:</b>                  The components identified by mark  or dotted line with mark  are critical for safety.                  Replace only with part number specified.</p>	<p><b>Note:</b>                  Les composants identifiés par une marque  sont critiques pour la sécurité.                  Ne les remplacer que par une pièce portant le numéro spécifié.</p>
--	--

When indicating parts by reference number, please include the board name.

4-1. FRAME SCHEMATIC DIAGRAM (1/2)



FRAME SCHEMATIC DIAGRAM (2/2)



05

4-2. PRINTED WIRING BOARDS AND SCHEMATIC DIAGRAMS

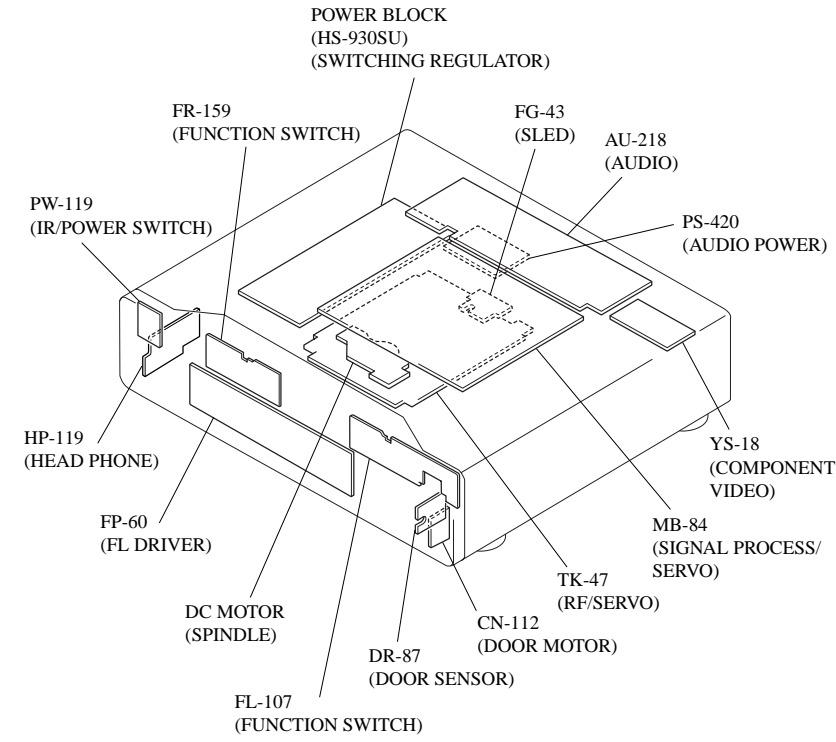
TK-47 (RF, SERVO) PRINTED WIRING BOARD

- Ref. No.: TK-47 board; 3,000 series -

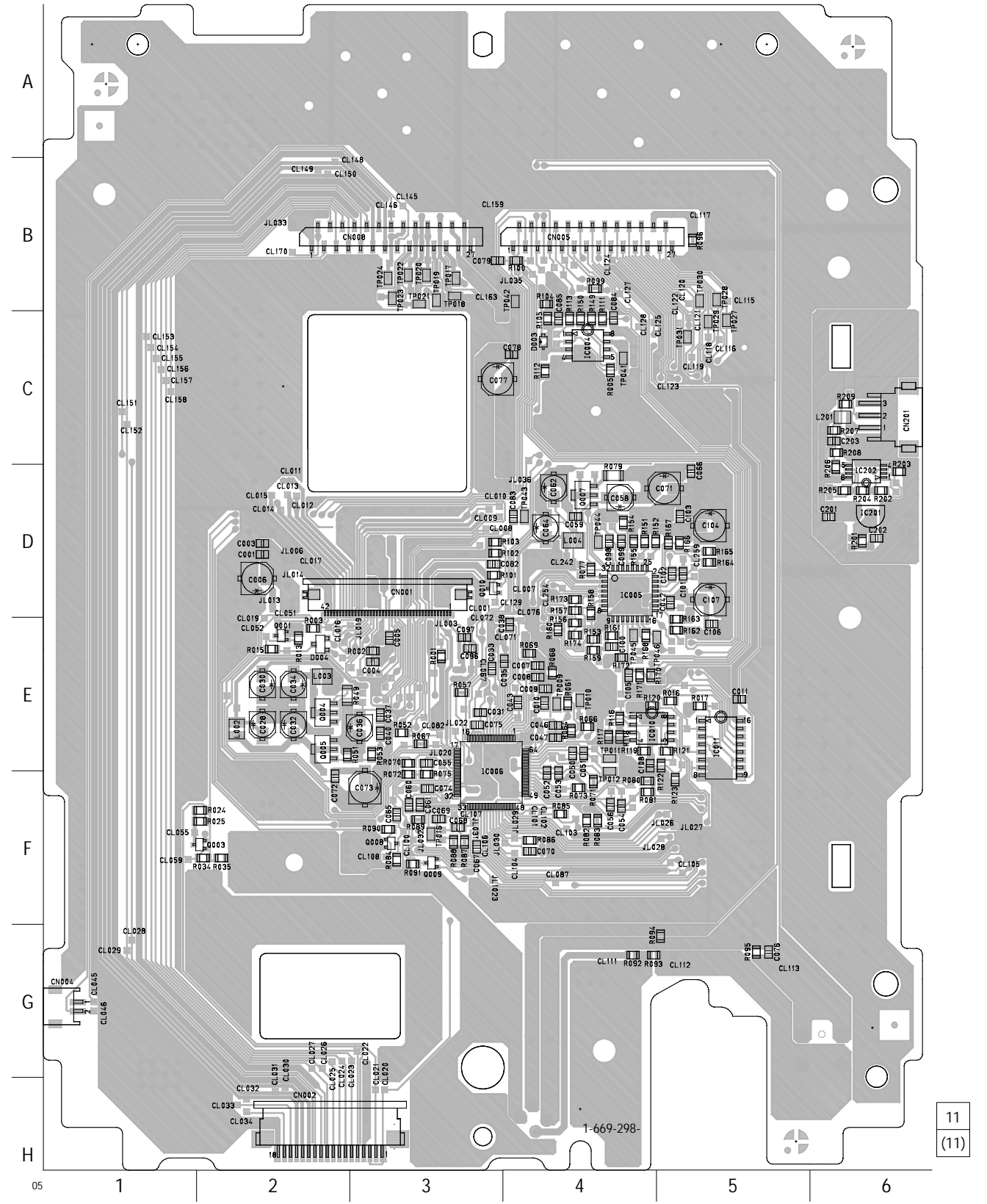
There are few cases that the part isn't mounted in this model is printed on this diagram.

TK-47 BOARD (SIDE A)

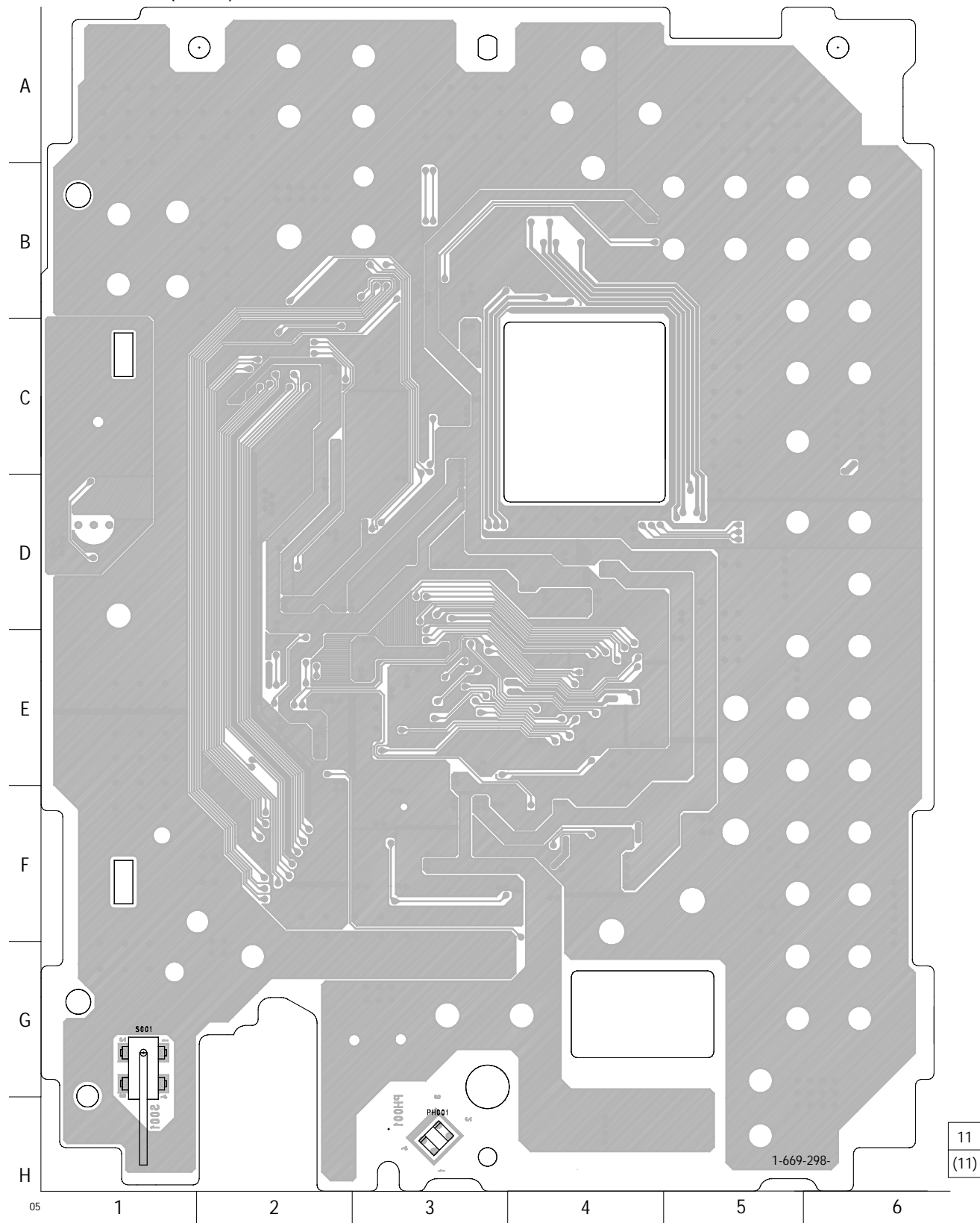
CN001	D-3
CN002	H-2
CN004	G-1
CN005	B-4
CN008	B-3
D003	C-4
D004	E-2
IC004	C-4
IC005	D-4
IC006	F-3
IC011	E-5
Q001	E-2
Q004	E-2
Q005	E-2
Q007	D-4
Q008	F-3
Q009	F-3
Q010	D-3



TK-47 BOARD(SIDE A)

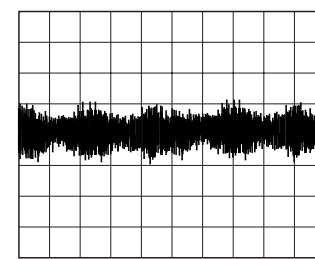


TK-47 BOARD(SIDE B)



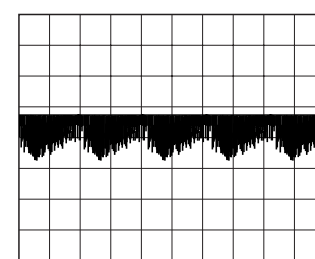
• Waveforms

1 IC006 ⑤1 - ⑤2 (DVD play)



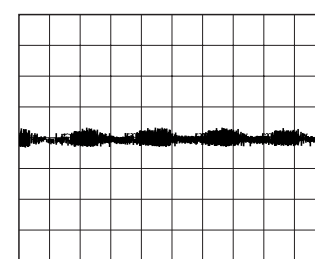
270 mVp-p (V)

2 IC006 ⑥1 - ⑥2 (DVD play)



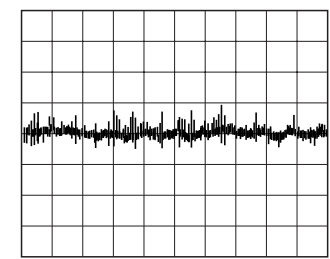
1.2 Vp-p (V)

3 IC006 ⑥3 - ⑥4 (DVD play)



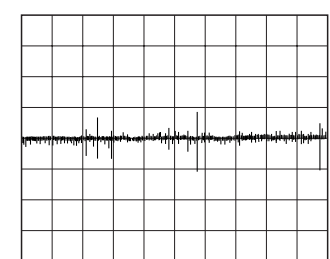
800 mVp-p (V)

4 IC005 ⑬ (CD play)



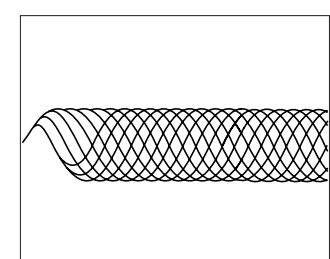
500 mV/DIV 1 ms/DIV

5 IC005 ⑮ (CD play)



500 mV/DIV 10 ms/DIV

6 IC005 ⑳ (CD play)



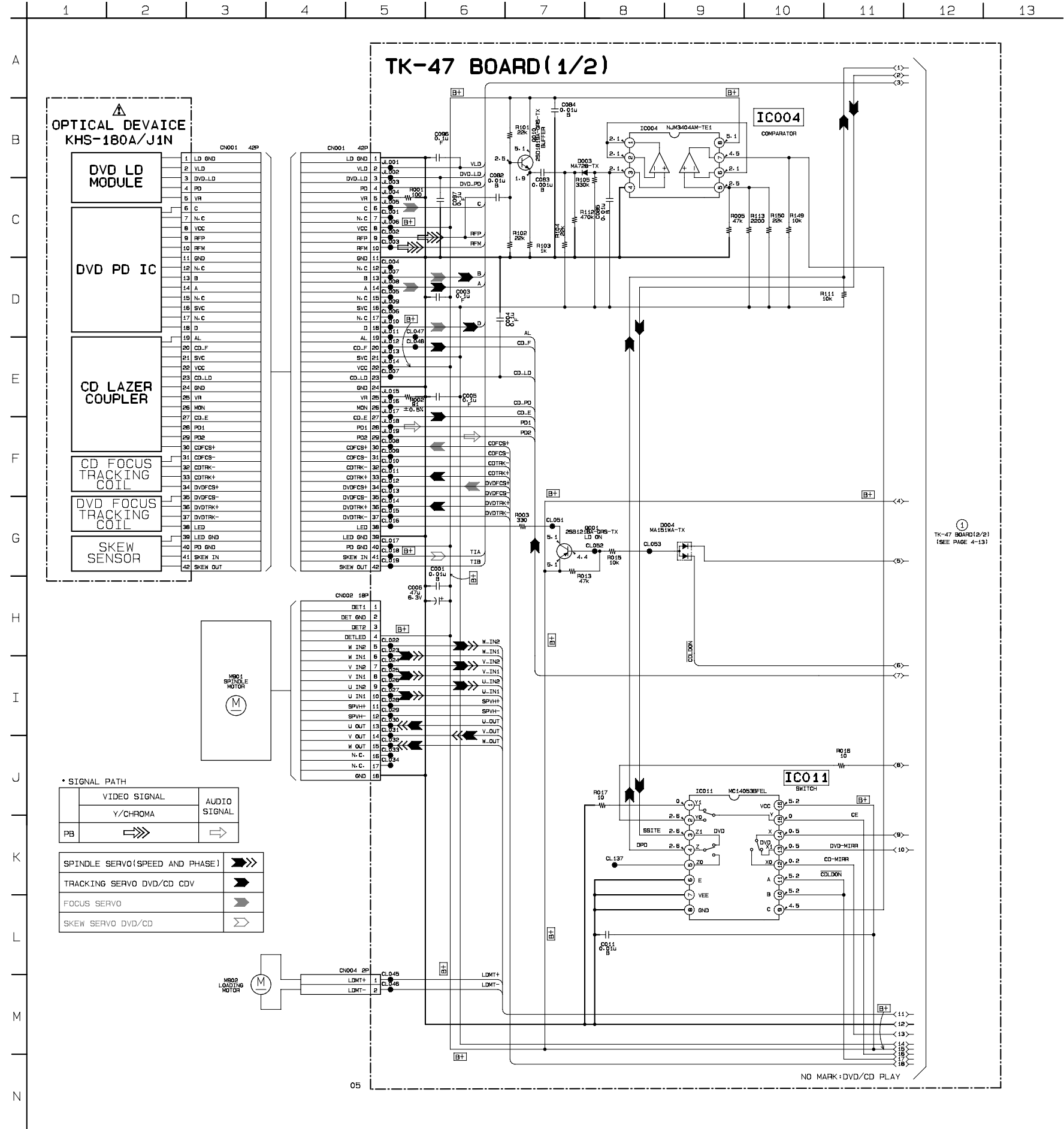
500 mV/DIV 1 μs/DIV

**Note:**  
The components identified by mark  $\triangle$  or dotted line with mark  $\triangle$  are critical for safety.  
Replace only with part number specified.

**Note:**  
Les composants identifiés par une marque  $\triangle$  sont critiques pour la sécurité.  
Ne les remplacer que par une pièce portant le numéro spécifié.

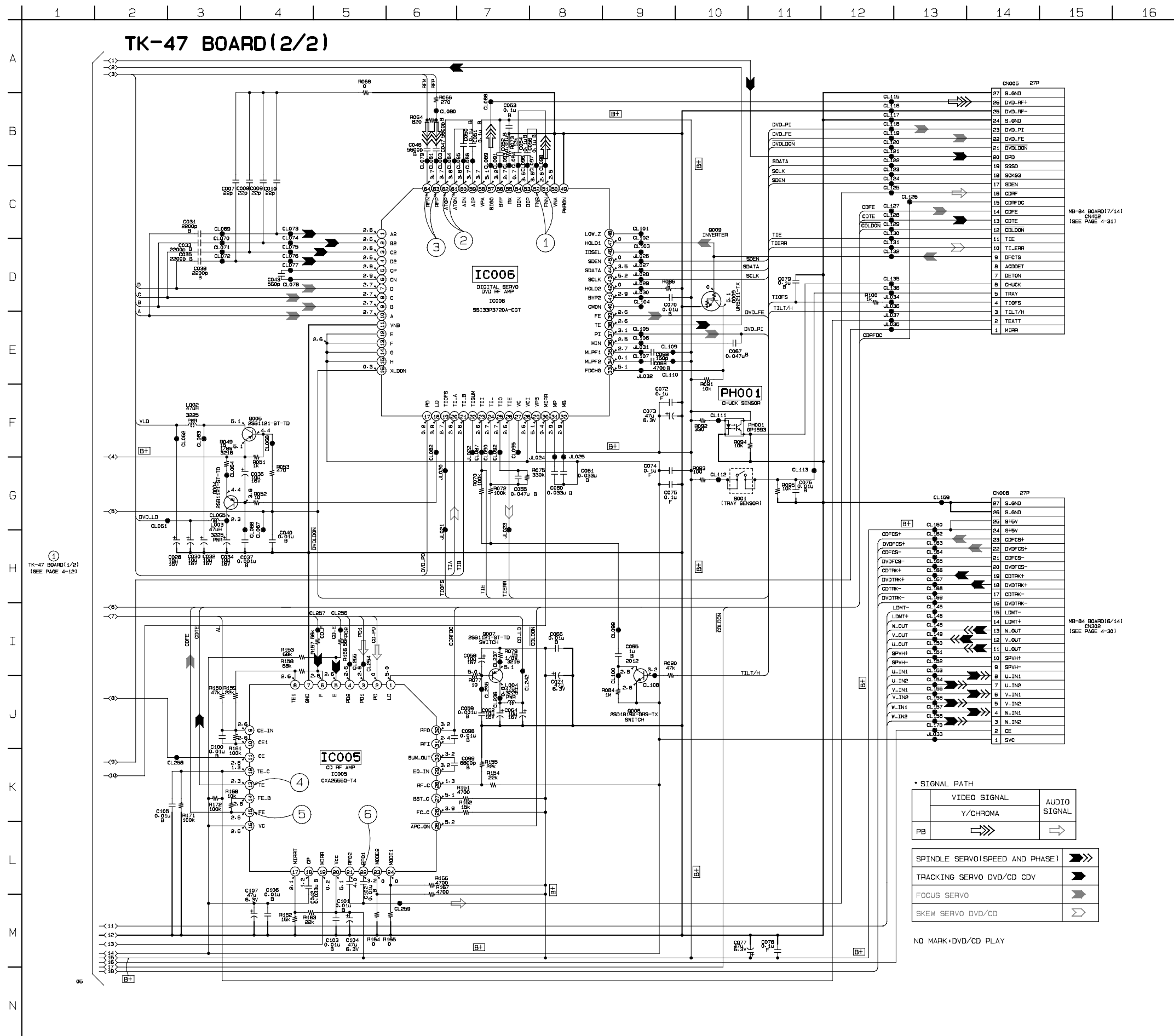
TK-47 (RF, SERVO 1) SCHEMATIC DIAGRAM

- Ref. No.: TK-47 board; 3,000 series -



TK-47 (RF, SERVO 2) SCHEMATIC DIAGRAM

- Ref. No.: TK-47 board; 3,000 series -

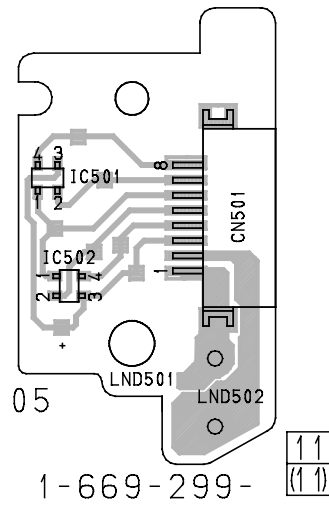




**MB-84 (SIGNAL PROCESS), FG-43 (SLED) PRINTED WIRING BOARDS**  
 - Ref. No.: MB-84 board; 2,000 series, FG-43 board; 1,000 series -

There are few cases that the part isn't mounted in this model is printed on this diagram.

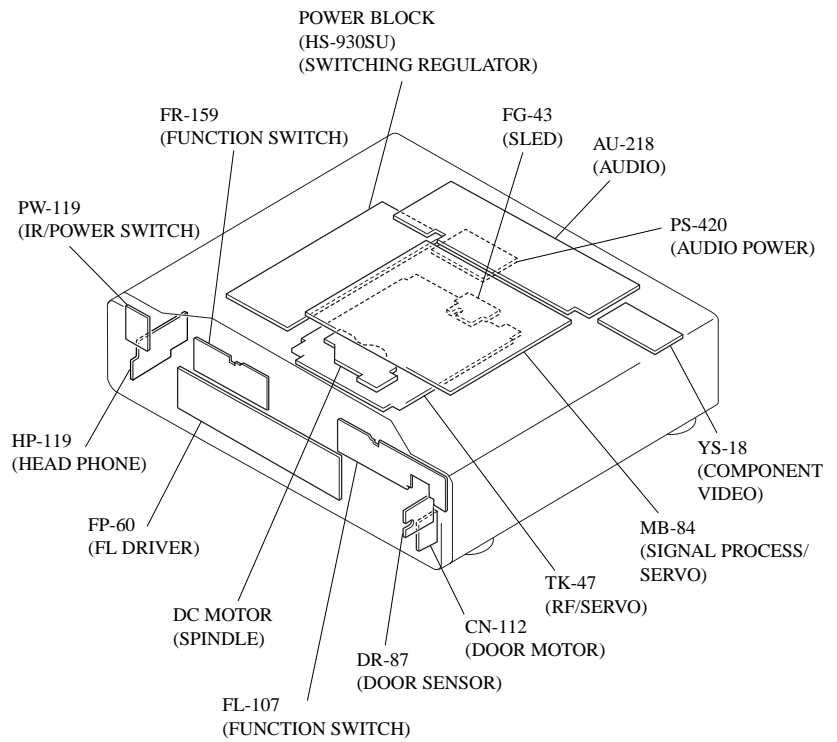
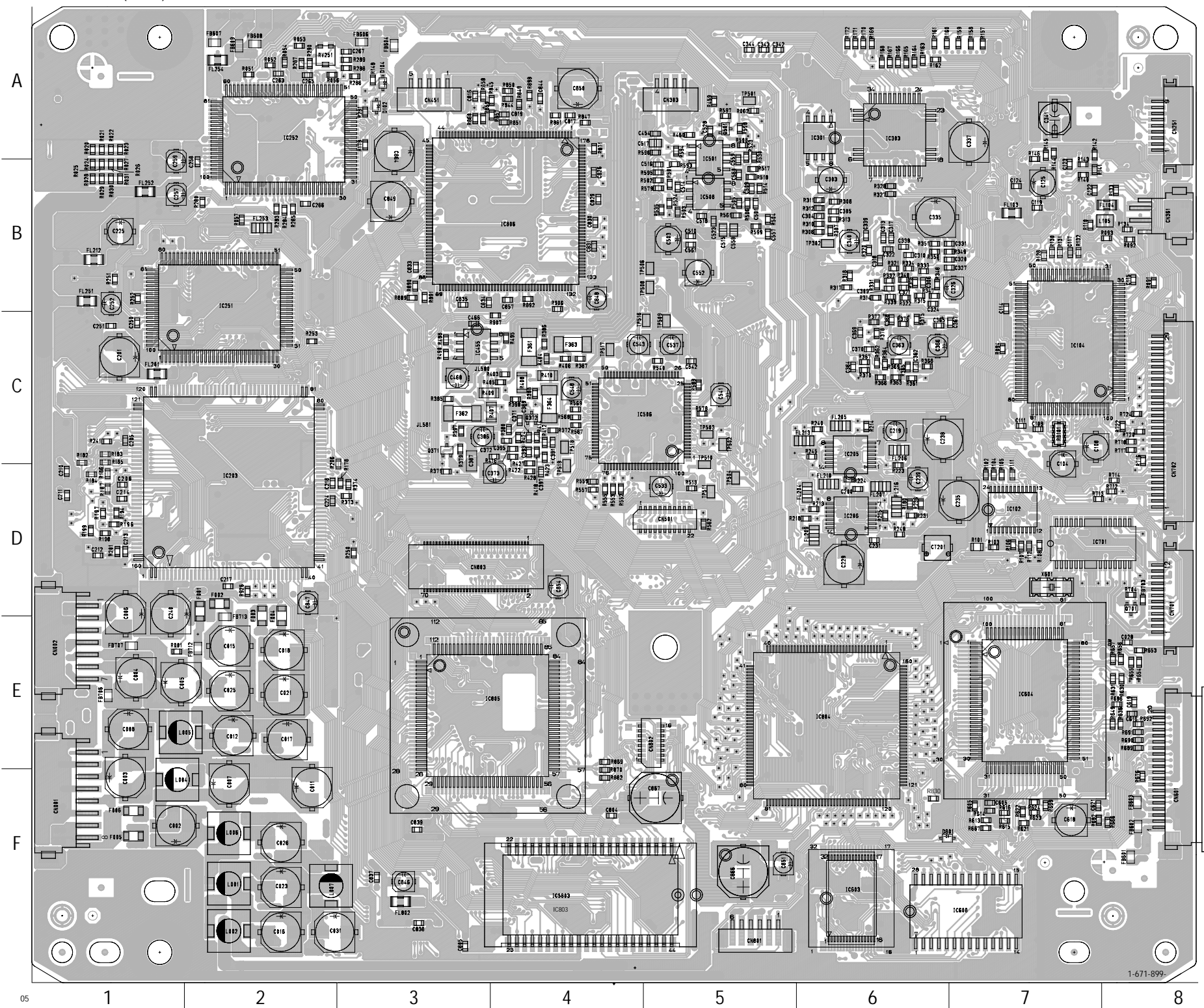
**FG-43 BOARD**



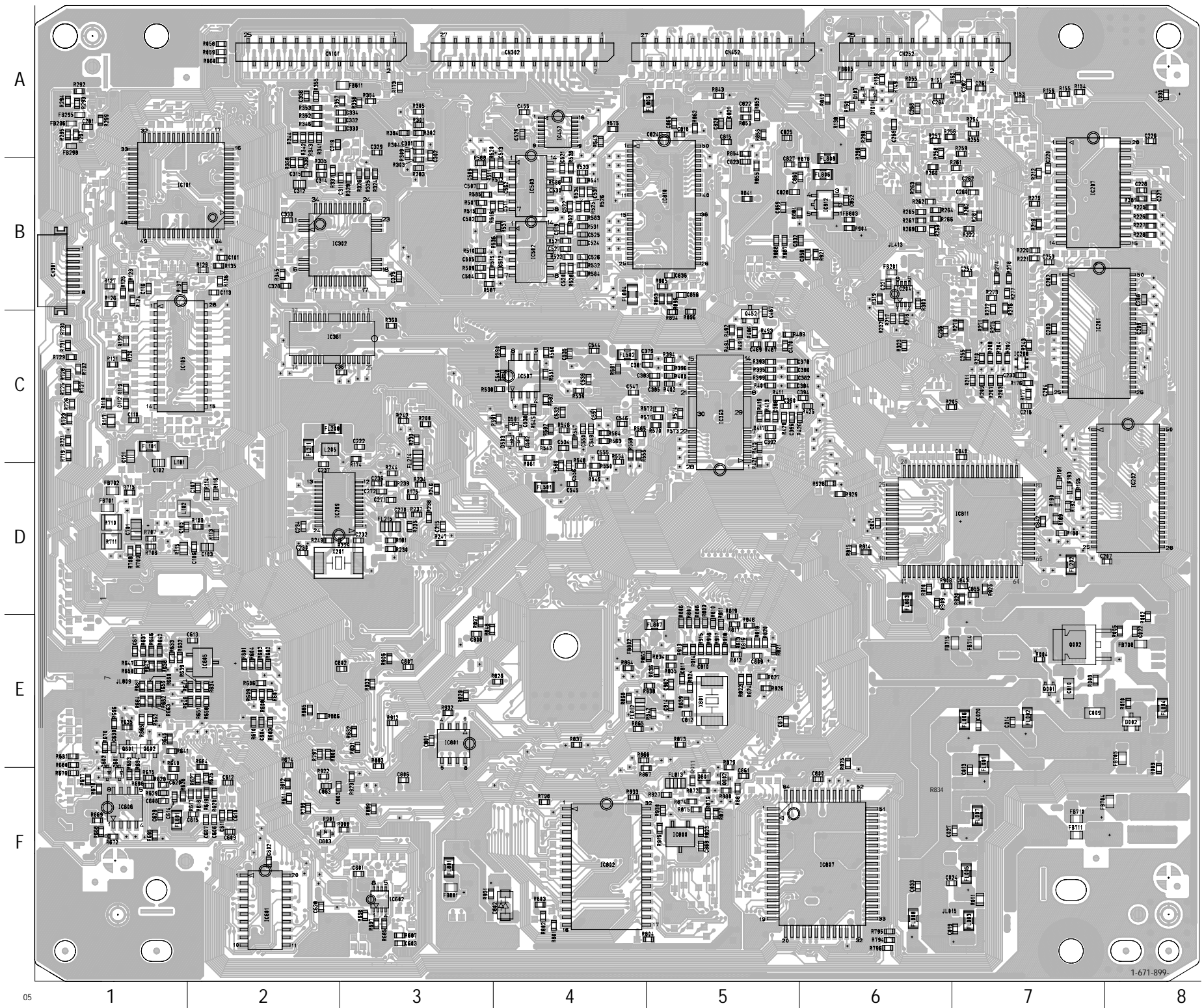
**MB-84 BOARD (SIDE A)**

- CN001 F-1
- CN002 E-1
- CN251 A-8
- CN303 A-5
- CN361 B-8
- CN451 A-3
- CN601 E-8
- CN801 F-5
  
- D102 A-3
- D801 F-6
  
- IC203 D-2
- IC205 C-6
- IC206 D-6
- IC251 B-2
- IC252 A-2
- IC301 A-6
- IC303 A-6
- IC455 C-3
- IC501 A-5
- IC506 C-4
- IC508 B-5
- IC603 F-6
- IC604 E-7
- IC803 F-4
- IC804 E-6
- IC805 E-3
- IC806 B-4
  
- Q371 C-3
- Q372 C-4
- Q501 A-5

**MB-84 BOARD (SIDE A)**



MB-84 BOARD(SIDE B)

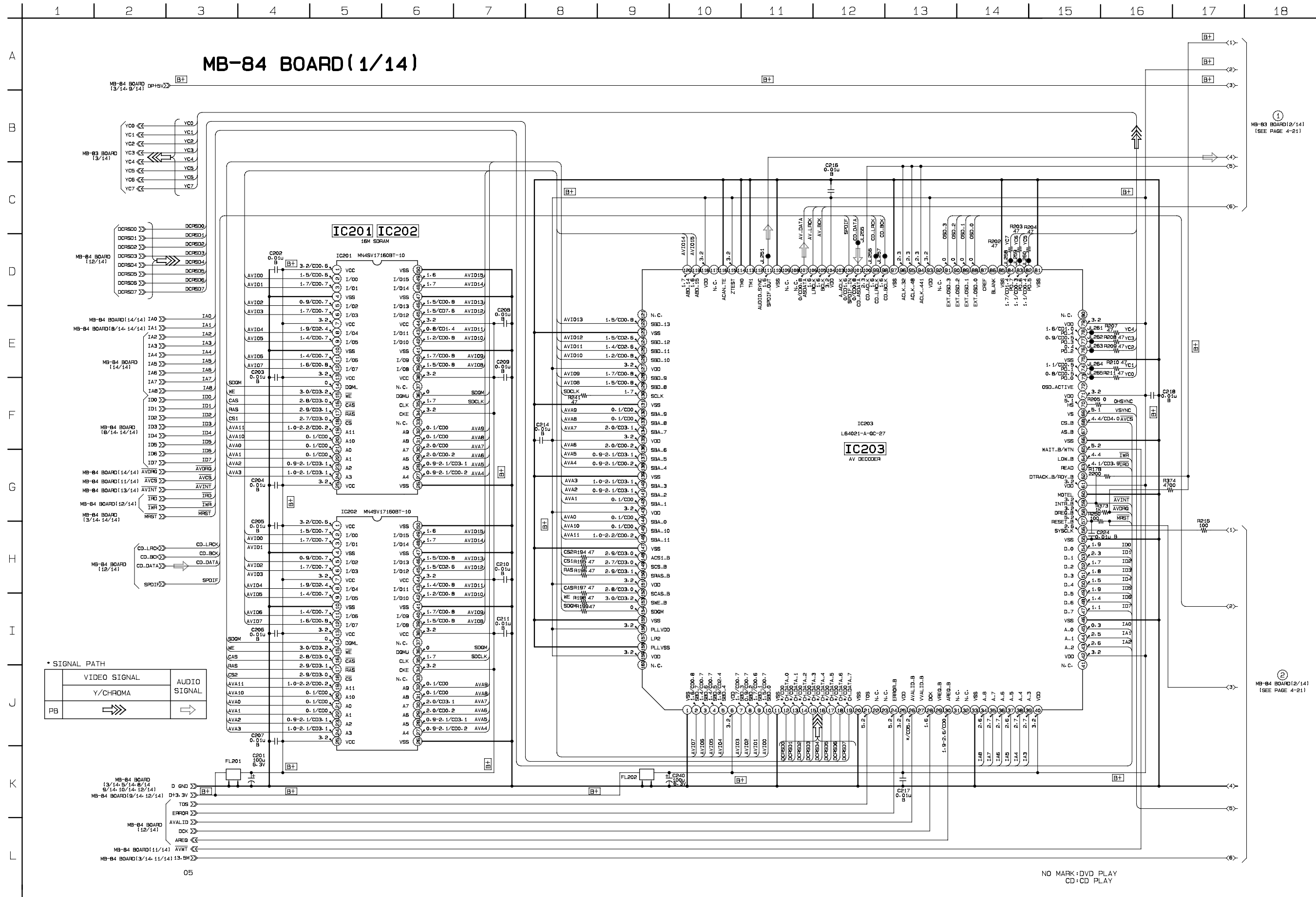


MB-84 BOARD (SIDE B)

- CN101 A-2
- CN252 A-6
- CN301 B-1
- CN302 A-4
- CN452 A-5
  
- D002 E-8
- D101 D-6
- D103 D-6
- D502 C-4
- D503 C-4
- D601 E-1
- D602 E-1
- D802 F-4
- D803 F-2
  
- IC201 C-7
- IC202 D-8
- IC204 B-6
- IC207 B-7
- IC208 C-7
- IC209 D-2
- IC302 B-2
- IC361 C-2
- IC363 C-5
- IC452 A-4
- IC502 B-4
- IC503 B-4
- IC507 C-4
- IC601 F-2
- IC602 F-3
- IC605 E-2
- IC606 F-1
- IC801 E-3
- IC802 F-4
- IC807 F-6
- IC810 B-5
- IC811 D-7
- IC812 B-6
  
- Q001 E-7
- Q002 E-7
- Q452 C-5
- Q601 E-1
- Q602 E-1

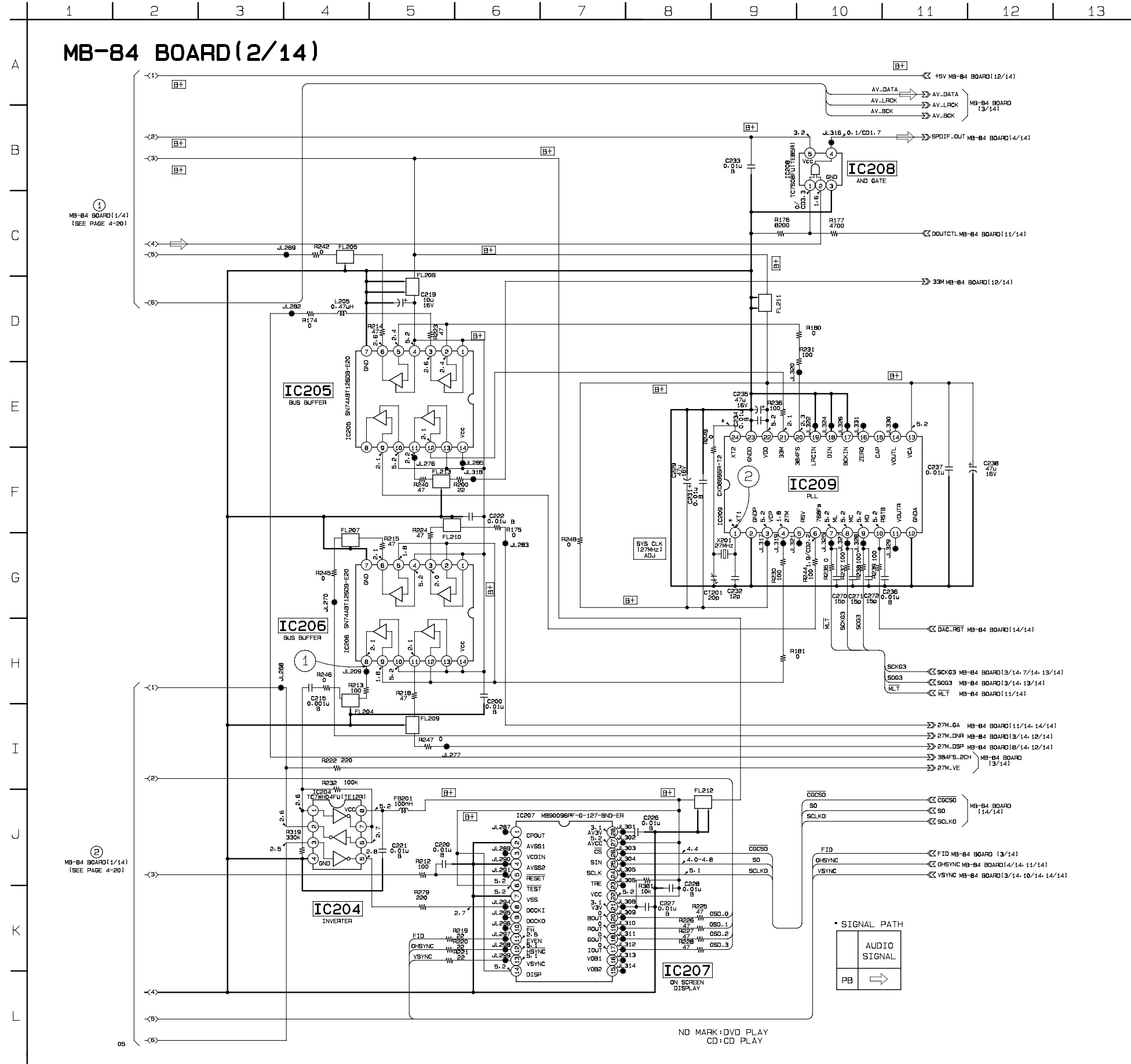
MB-84 (AV DECODER) SCHEMATIC DIAGRAM • See page 4-15 to 4-18 for printed wiring board.

– Ref. No.: MB-84 board; 2,000 series –



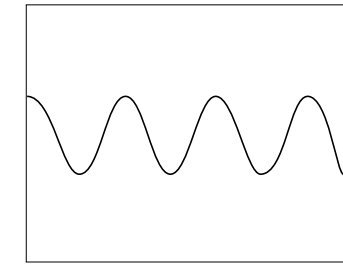
**MB-84 (CLOCK GENERATOR) SCHEMATIC DIAGRAM • See page 4-15 to 4-18 for printed wiring board.**

- Ref. No.: MB-84 board; 2,000 series -



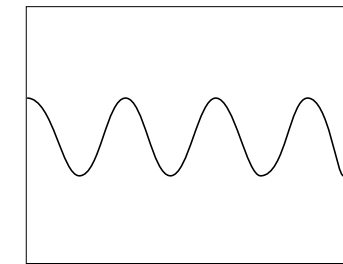
• Waveforms

① IC206 ⑧



3.28 Vp-p 27 MHz

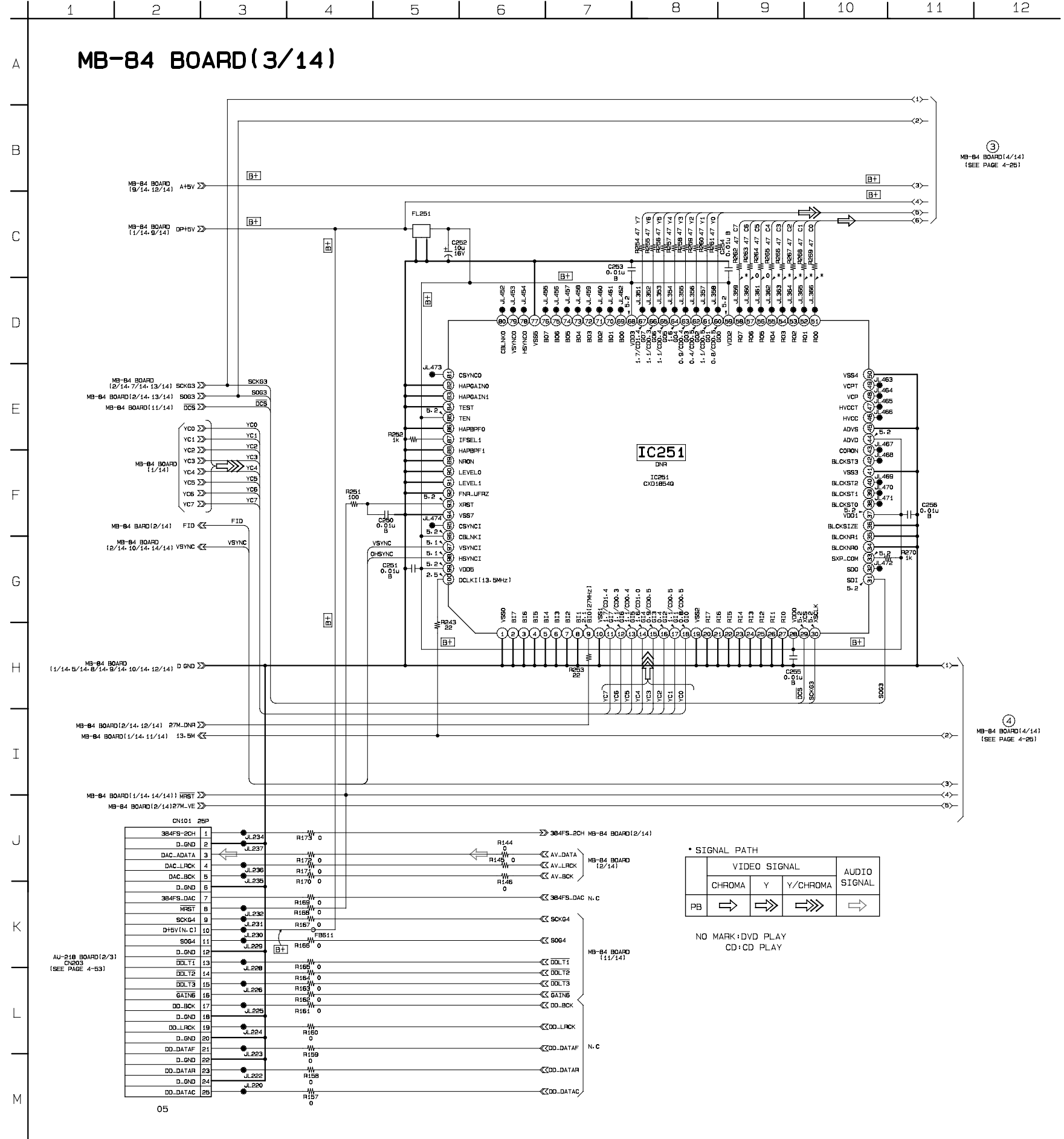
② IC209 ①



1.4 Vp-p 27 MHz

**MB-84 (DNR) SCHEMATIC DIAGRAM** • See page 4-15 to 4-18 for printed wiring board.

- Ref. No.: MB-84 board; 2,000 series -



③ MB-84 BOARD(4/14)  
(SEE PAGE 4-25)

④ MB-84 BOARD(4/14)  
(SEE PAGE 4-25)

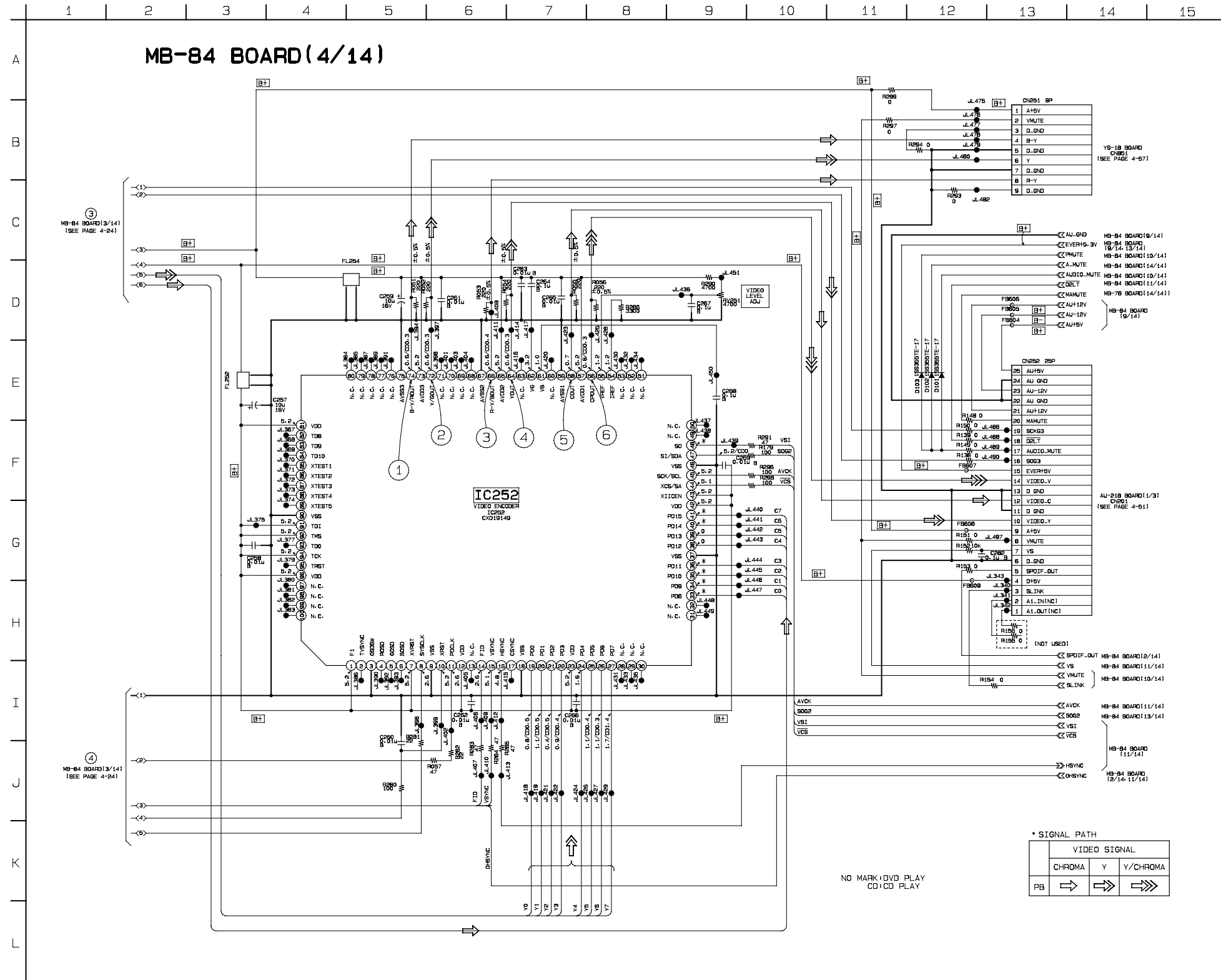
\* SIGNAL PATH

	VIDEO SIGNAL			AUDIO SIGNAL
	CHROMA	Y	Y/CHROMA	
PB	⇐	⇐	⇐	⇐

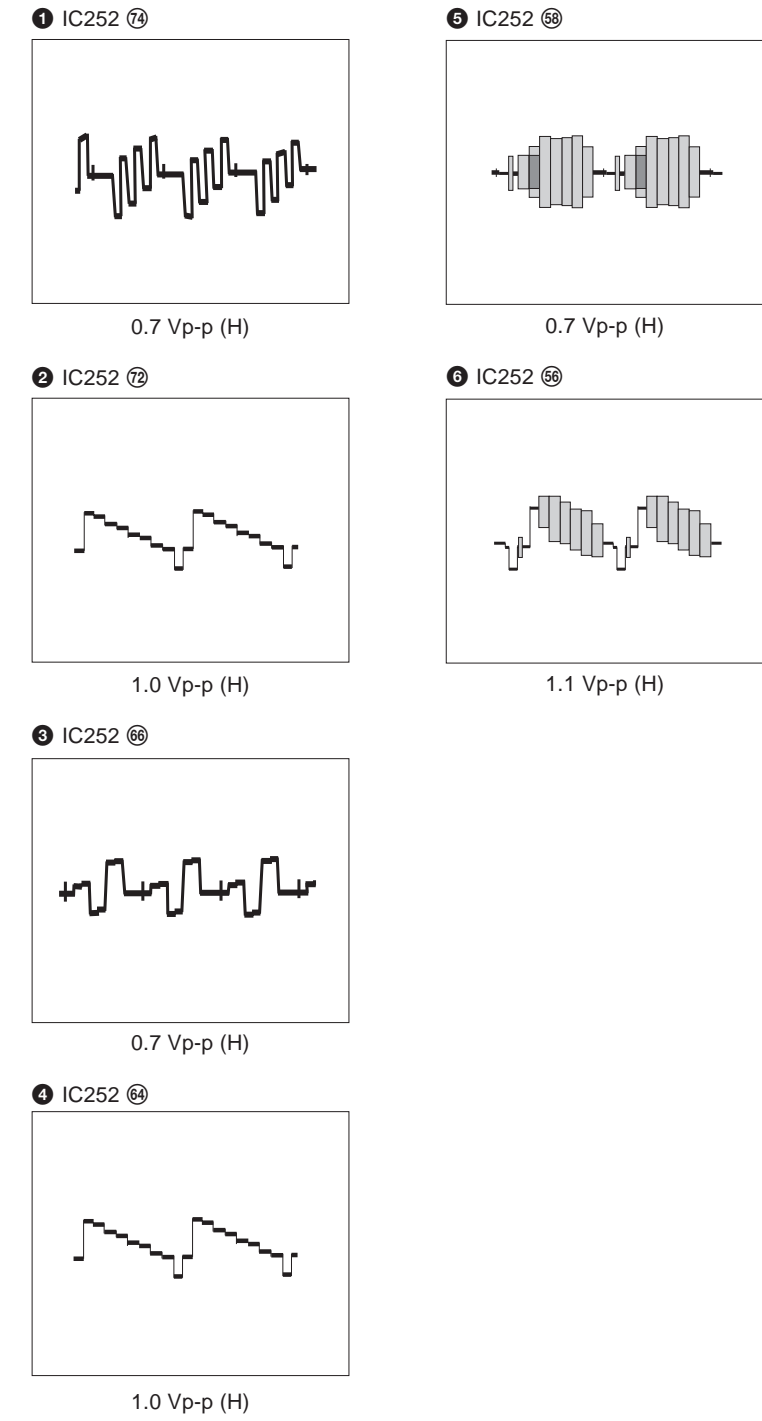
NO MARK: DVD PLAY  
CD: CD PLAY

**MB-84 (VIDEO ENCODER) SCHEMATIC DIAGRAM** • See page 4-15 to 4-18 for printed wiring board.

– Ref. No.: MB-84 board; 2,000 series –



• Waveforms

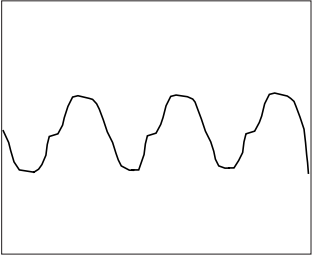


**MB-84 (DRIVE 1) SCHEMATIC DIAGRAM** • See page 4-15 to 4-18 for printed wiring board.

- Ref. No.: MB-84 board; 2,000 series -

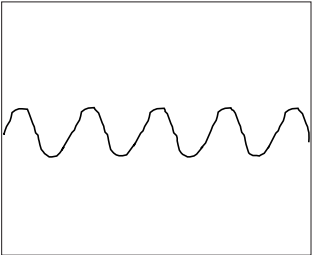
• Waveforms

① IC303 (19, 22, 23) (DVD play)

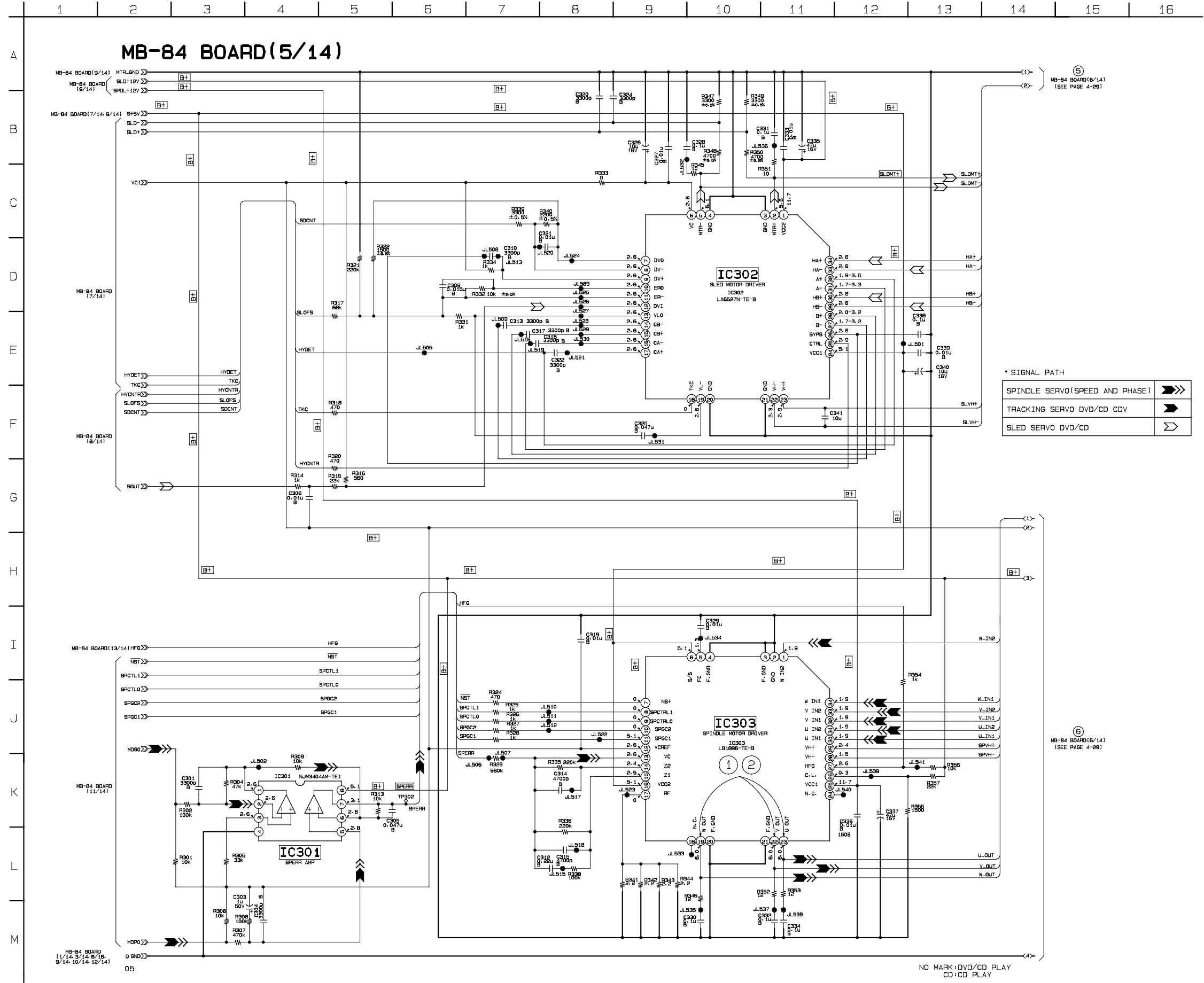


5.2 Vp-p 160 Hz

② IC303 (19, 22, 23) (CD play)

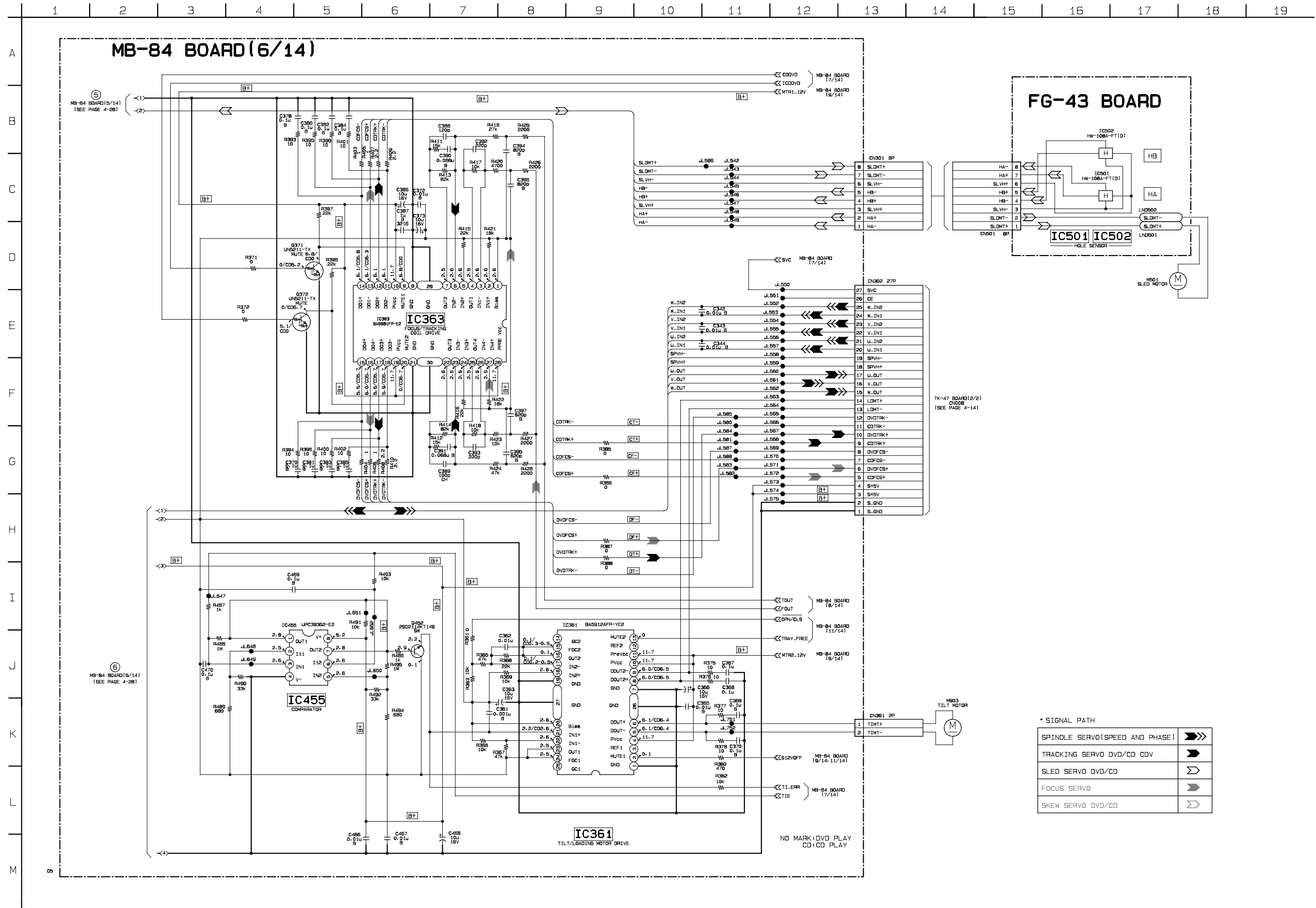


1.84 Vp-p 45 Hz



**MB-84 (DRIVE 2), FG-43 (SLED) SCHEMATIC DIAGRAMS • See page 4-15 to 4-18 for printed wiring boards.**

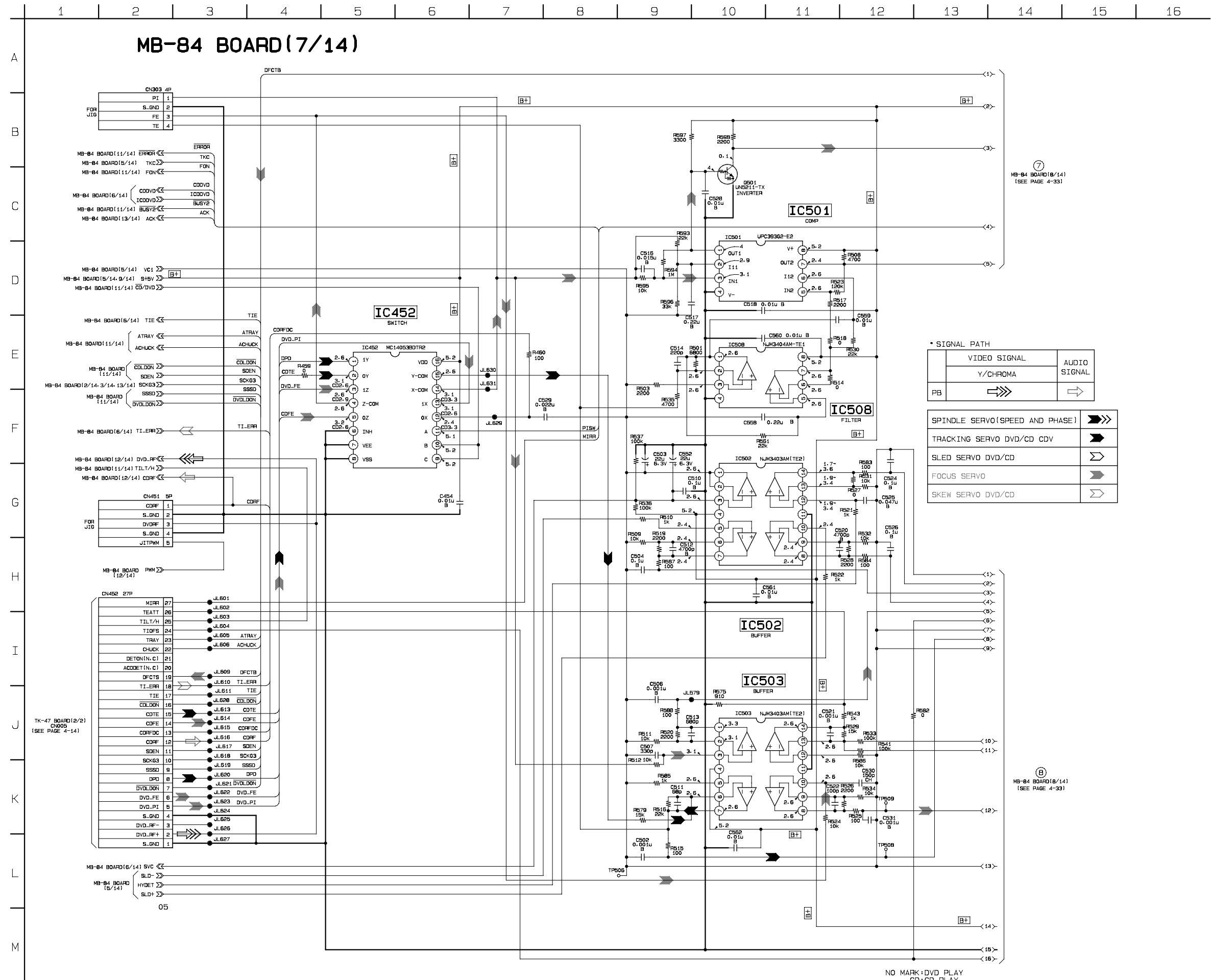
– Ref. No.: MB-84 board; 2,000 series, FG-43 board; 1,000 series –





MB-84 (DSP 1) SCHEMATIC DIAGRAM • See page 4-15 to 4-18 for printed wiring board.

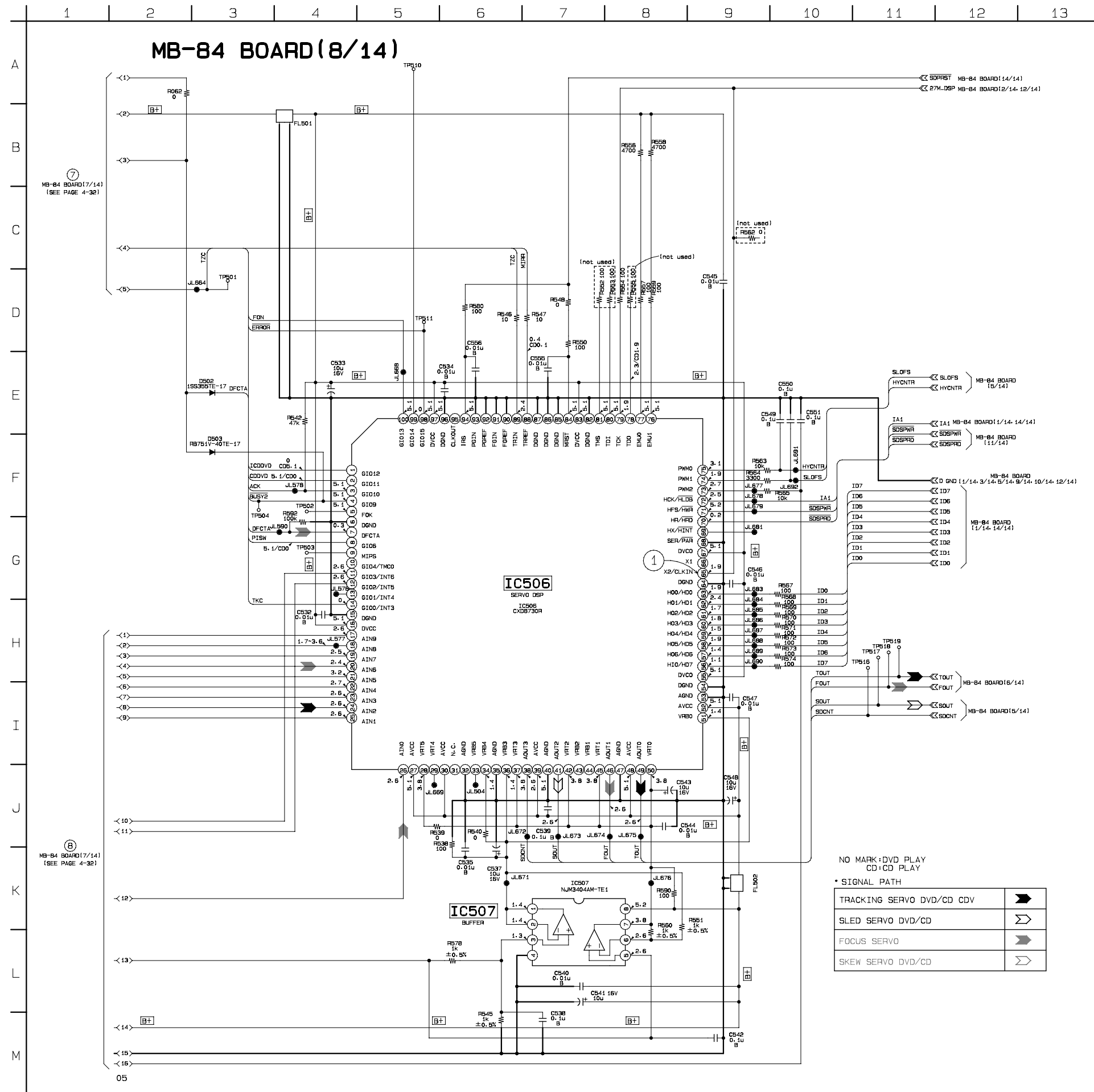
- Ref. No.: MB-84 board; 2,000 series -



NO MARK: DVD PLAY  
CD: CD PLAY

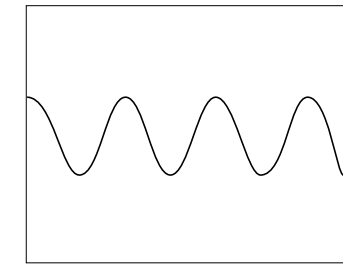
**MB-84 (DSP 2) SCHEMATIC DIAGRAM** • See page 4-15 to 4-18 for printed wiring board.

– Ref. No.: MB-84 board; 2,000 series –



• Waveform

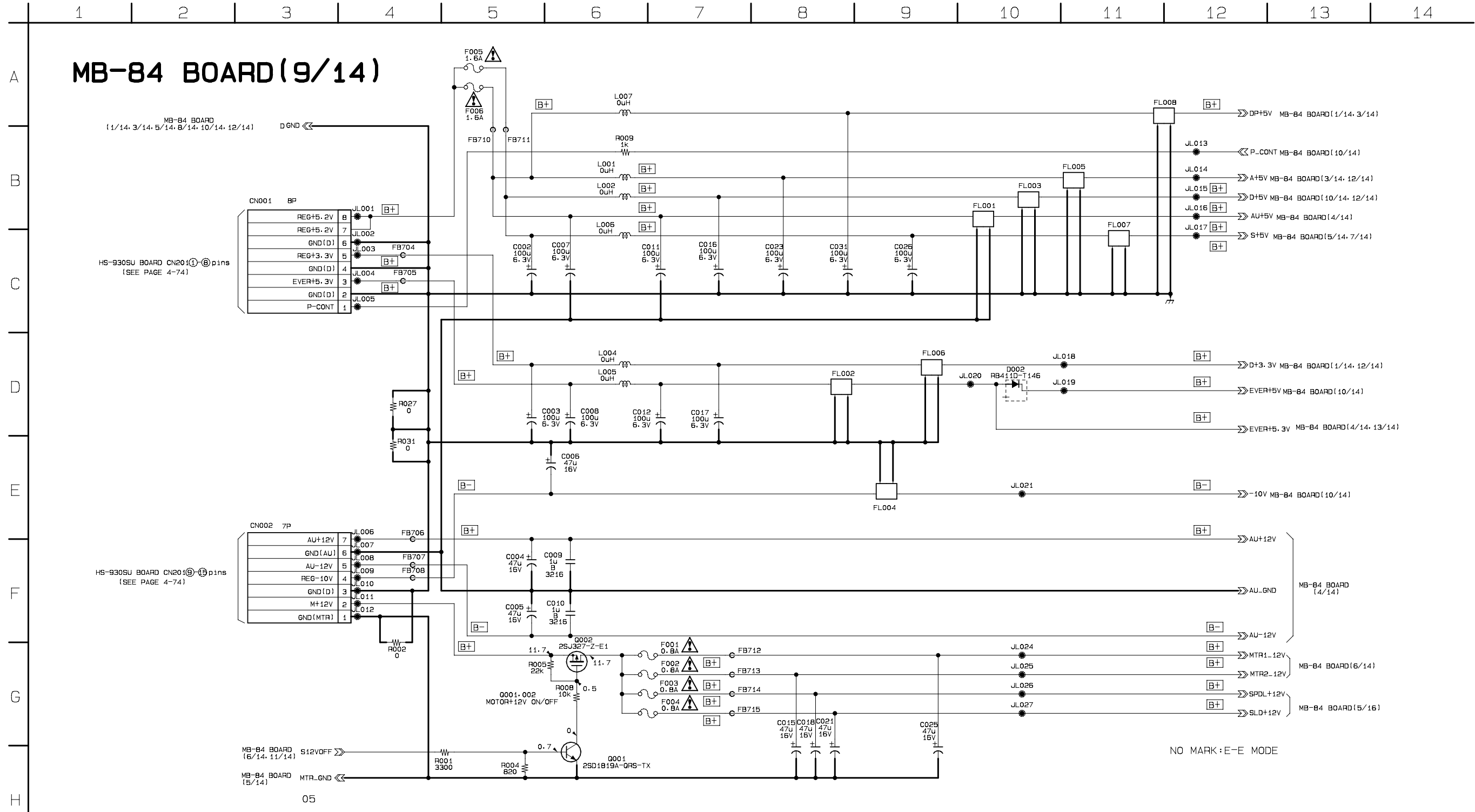
① IC506 ⑤



3.6 Vp-p 27 MHz

**MB-84 (BIAS) SCHEMATIC DIAGRAM** • See page 4-15 to 4-18 for printed wiring board.

- Ref. No.: MB-84 boards; 2,000 series -

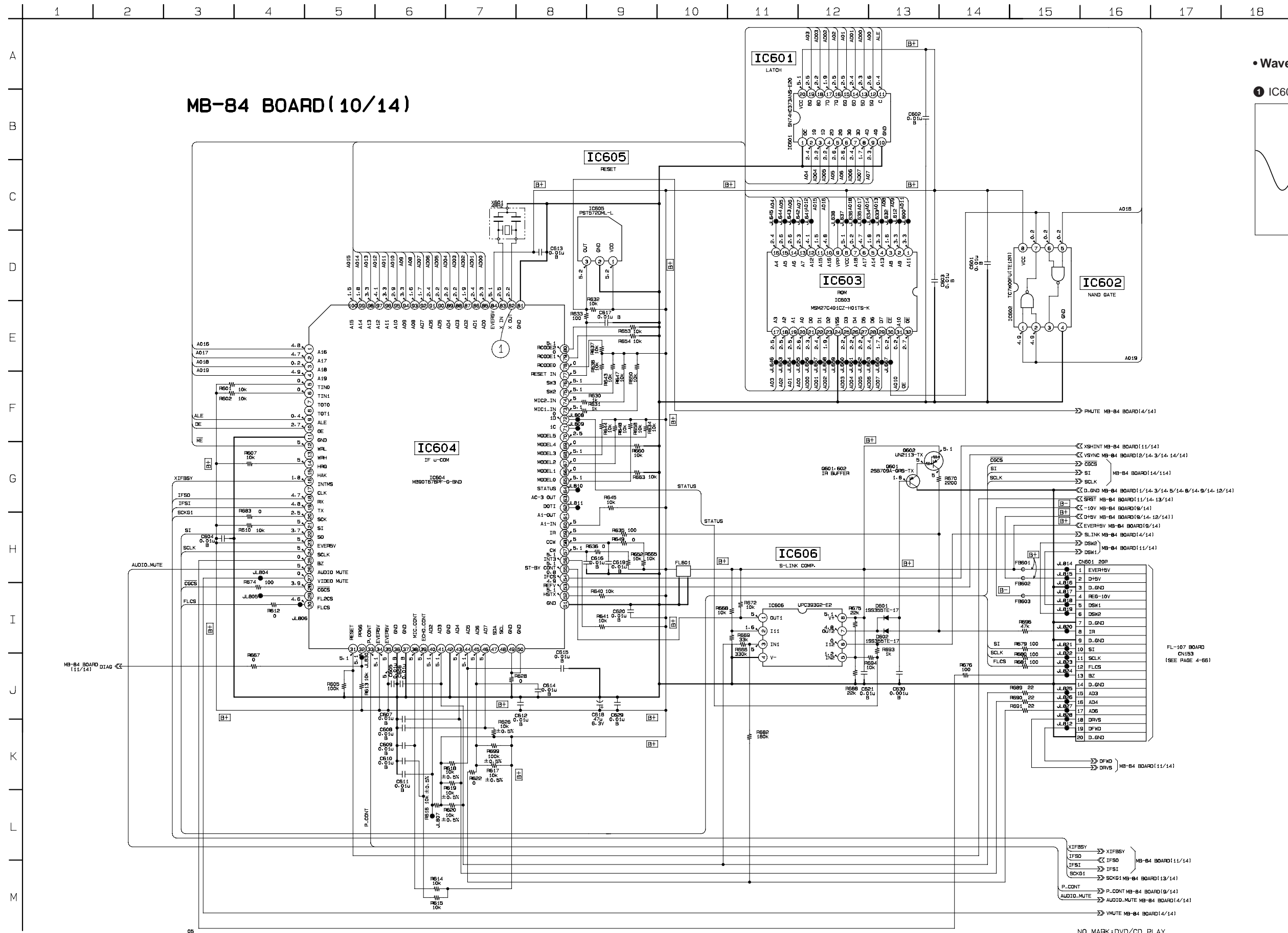


**Note:**  
The components identified by mark  $\triangle$  or dotted line with mark  $\triangle$  are critical for safety. Replace only with part number specified.

**Note:**  
Les composants identifiés par une marque  $\triangle$  sont critiques pour la sécurité. Ne les remplacer que par une pièce portant le numéro spécifié.

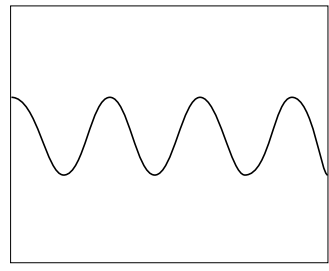
MB-84 (IF  $\mu$ -COM) SCHEMATIC DIAGRAM • See page 4-15 to 4-18 for printed wiring board.

- Ref. No.: MB-84 board; 2,000 series -



• Waveform

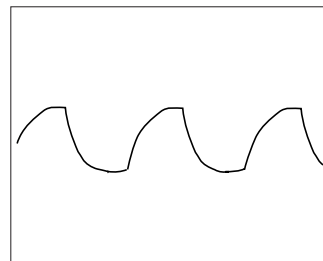
① IC604



5.6 Vp-p 4 MHz

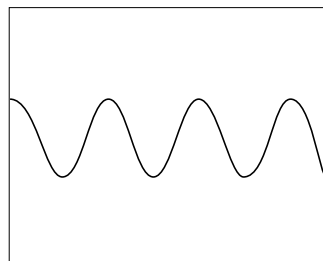
• Waveforms

1 IC804 (11)



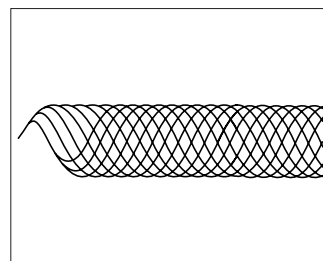
225 mVp-p 13.5 MHz

2 IC804 (12)



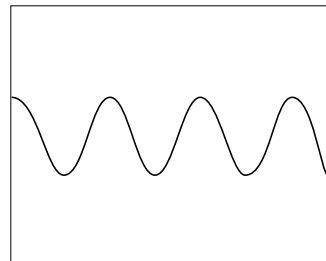
3.3 Vp-p 27 MHz

3 IC806 (10)



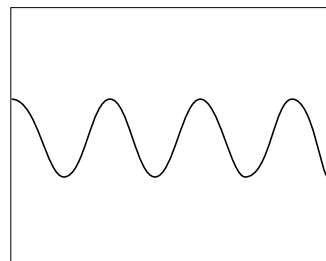
1.5 Vp-p

4 IC806 (12)



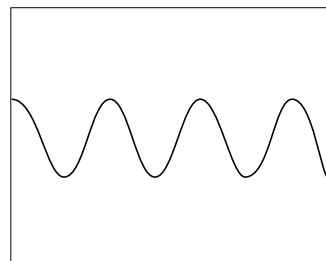
3.0 Vp-p 33 MHz

5 IC806 (12)



3.4 Vp-p 27 MHz

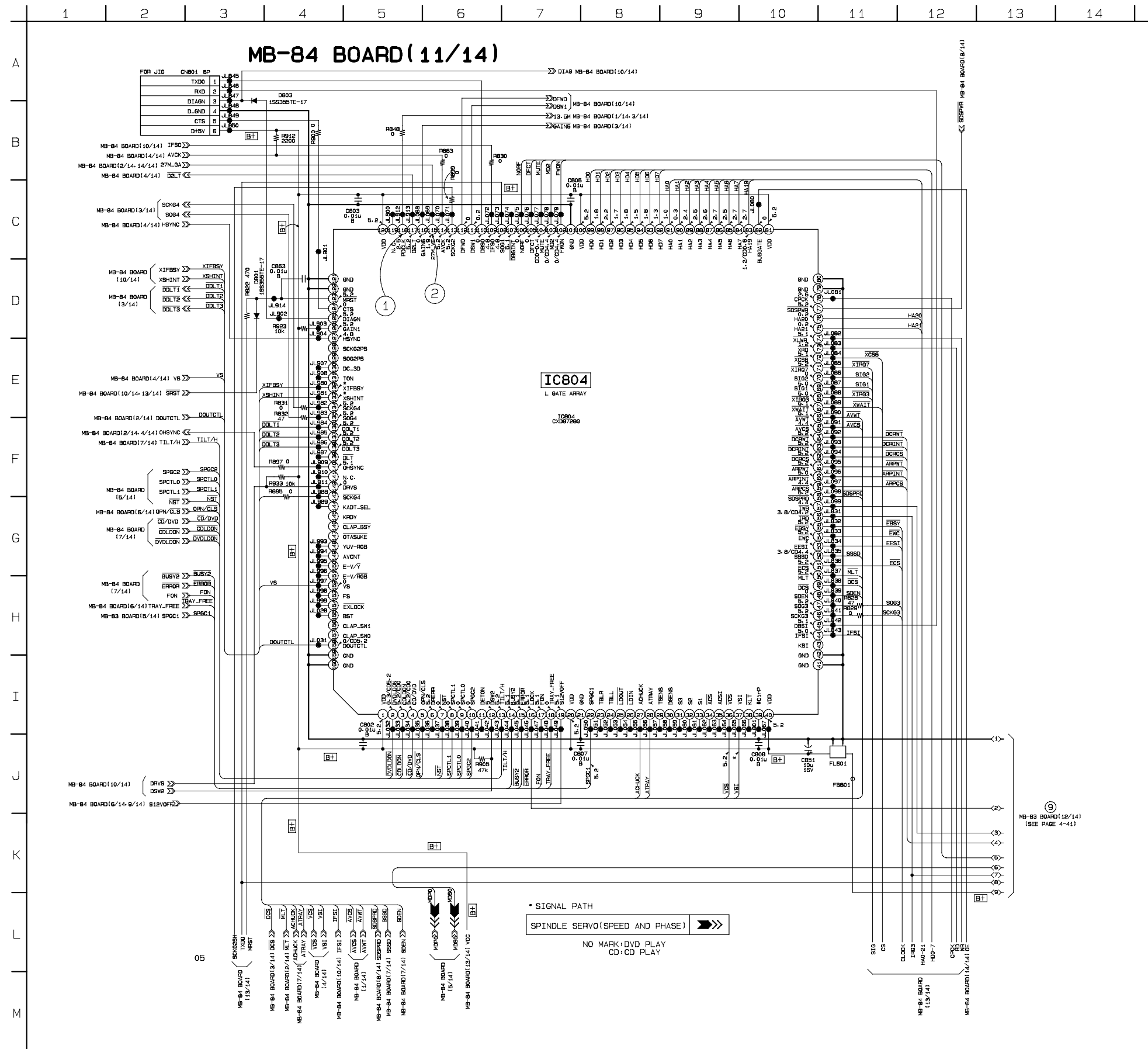
6 IC811 (51)



3.4 Vp-p 27 MHz

MB-84 (L GATE ARRAY) SCHEMATIC DIAGRAM • See page 4-15 to 4-18 for printed wiring board.

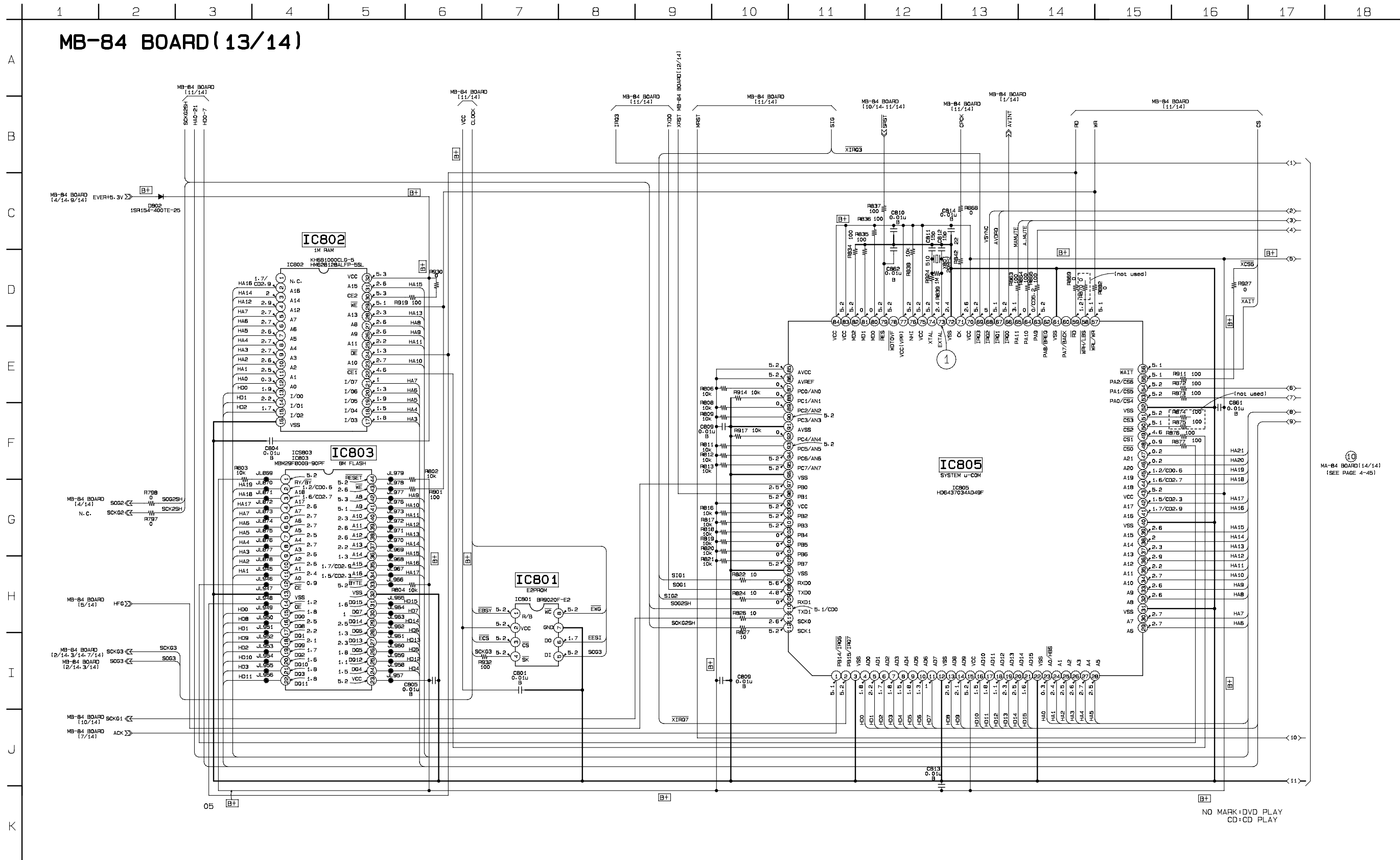
- Ref. No.: MB-84 board; 2,000 series -





**MB-84 (SYSTEM μ-COM) SCHEMATIC DIAGRAM** • See page 4-15 to 4-18 for printed wiring board.

- Ref. No.: MB-84 board; 2,000 series -

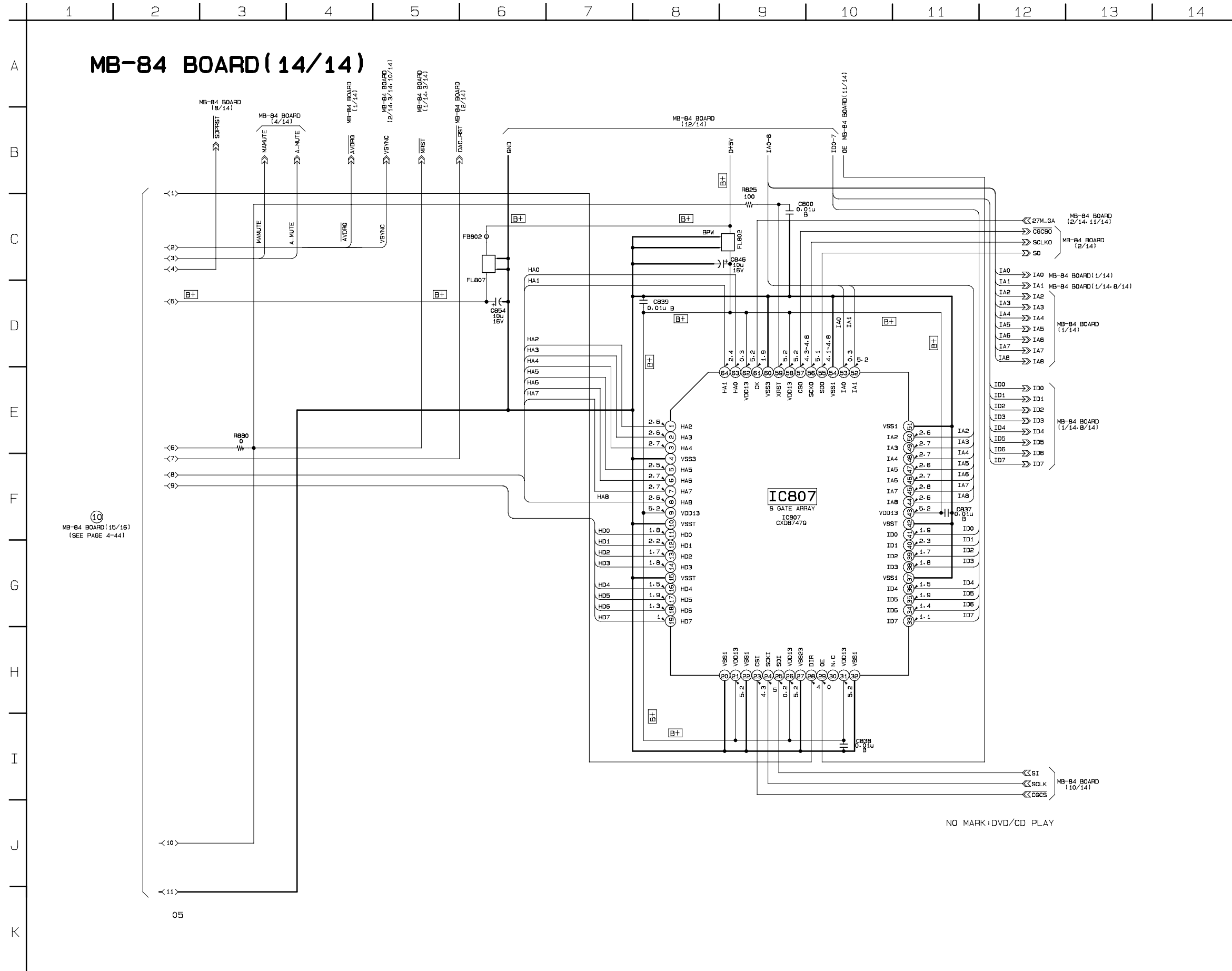


MA-84 BOARD (14/14)  
(SEE PAGE 4-45)

NO MARK DVD PLAY  
CD/CD PLAY

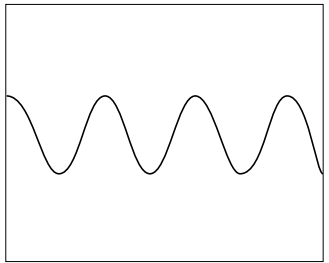
MB-84 (S GATE ARRAY) SCHEMATIC DIAGRAM • See page 4-15 to 4-18 for printed wiring board.

- Ref. No.: MB-84 board; 2,000 series -



• Waveform

① IC805 ㉓



4.4 Vp-p 20 MHz

⑩ MB-84 BOARD (15/16)  
(SEE PAGE 4-44)

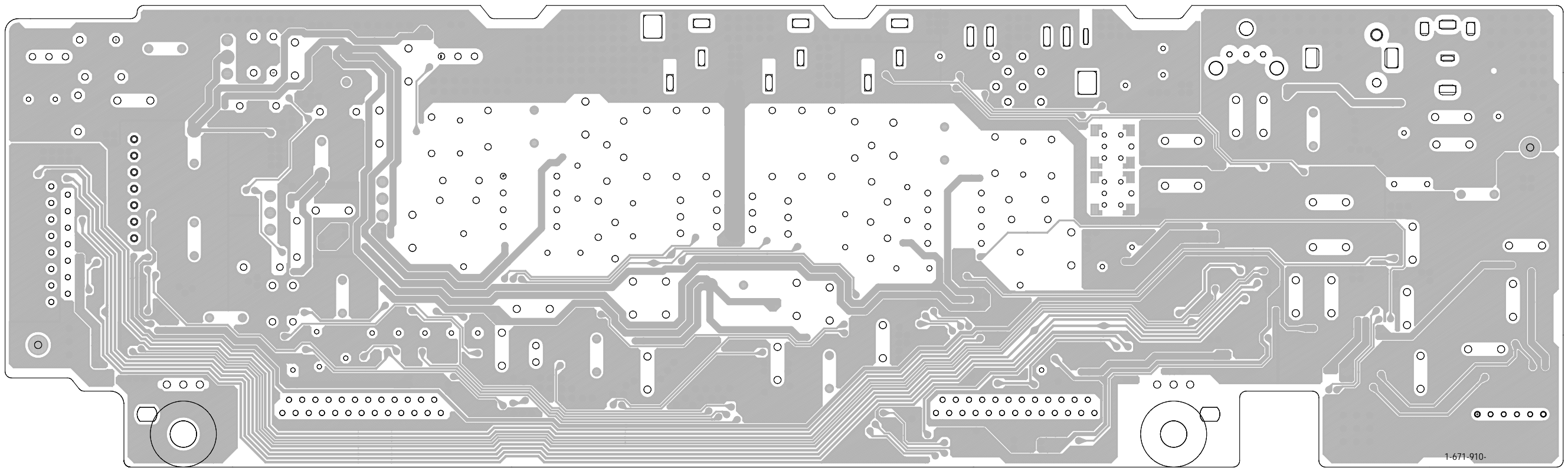
NO MARK: DVD/CD PLAY



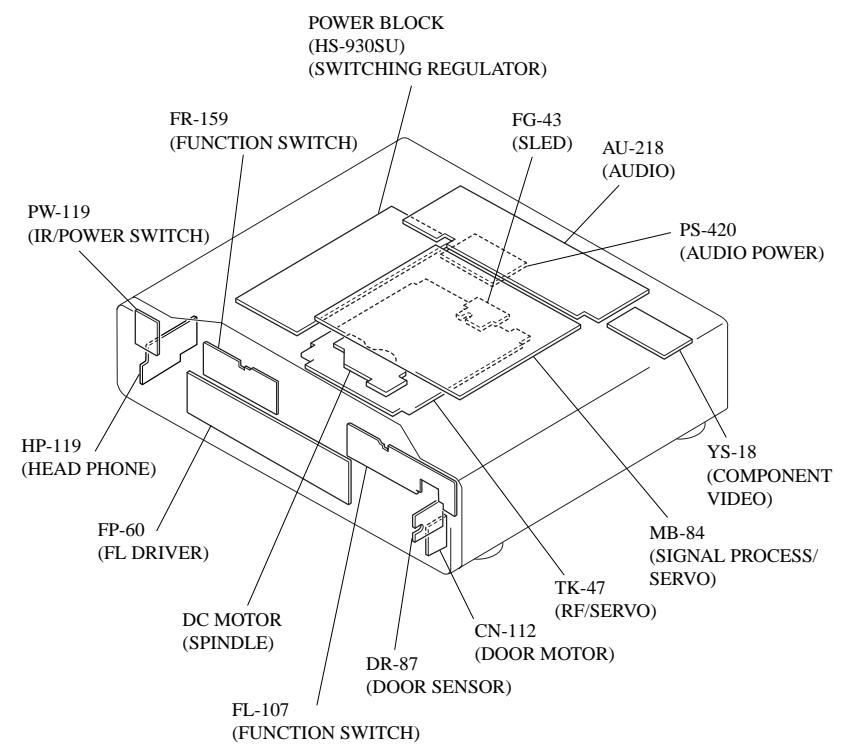
**AU-218 (AUDIO) PRINTED WIRING BOARD**  
– Ref. No.: AU-218 board; 3,000 series –

There are few cases that the part isn't mounted in this model is printed on this diagram.

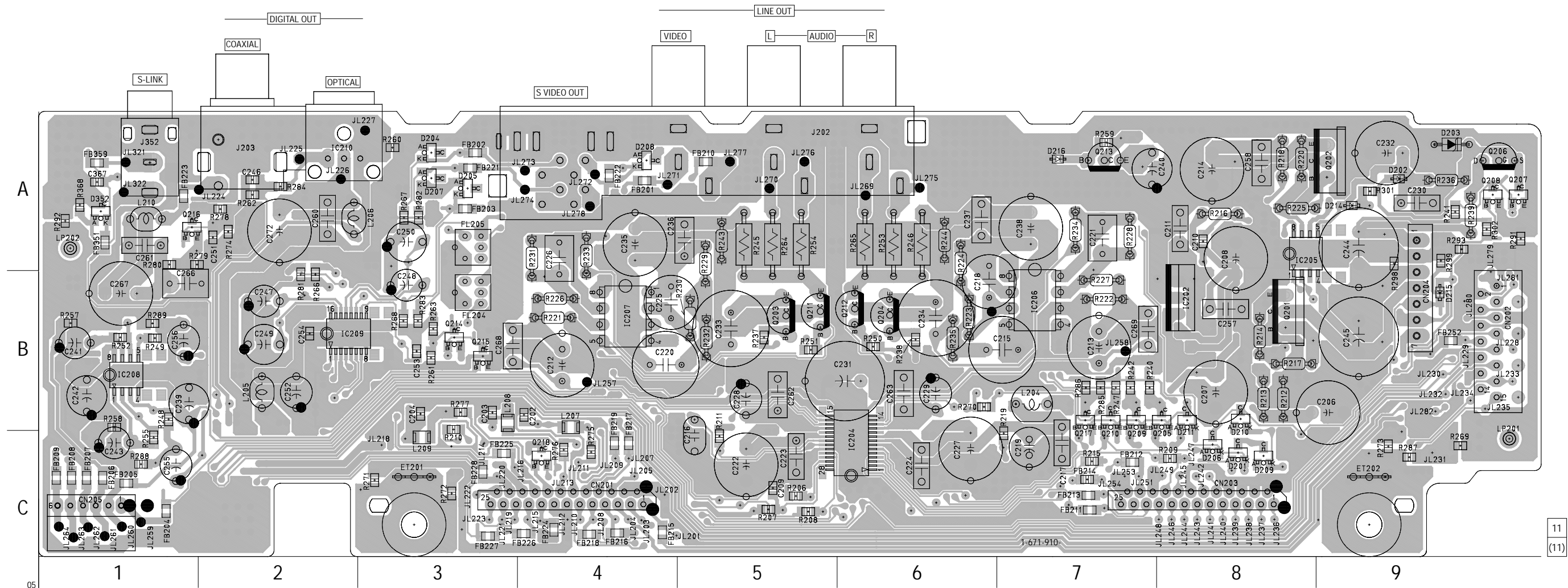
**AU-218 BOARD(SIDE A)**



05



AU-218 BOARD(SIDE B)

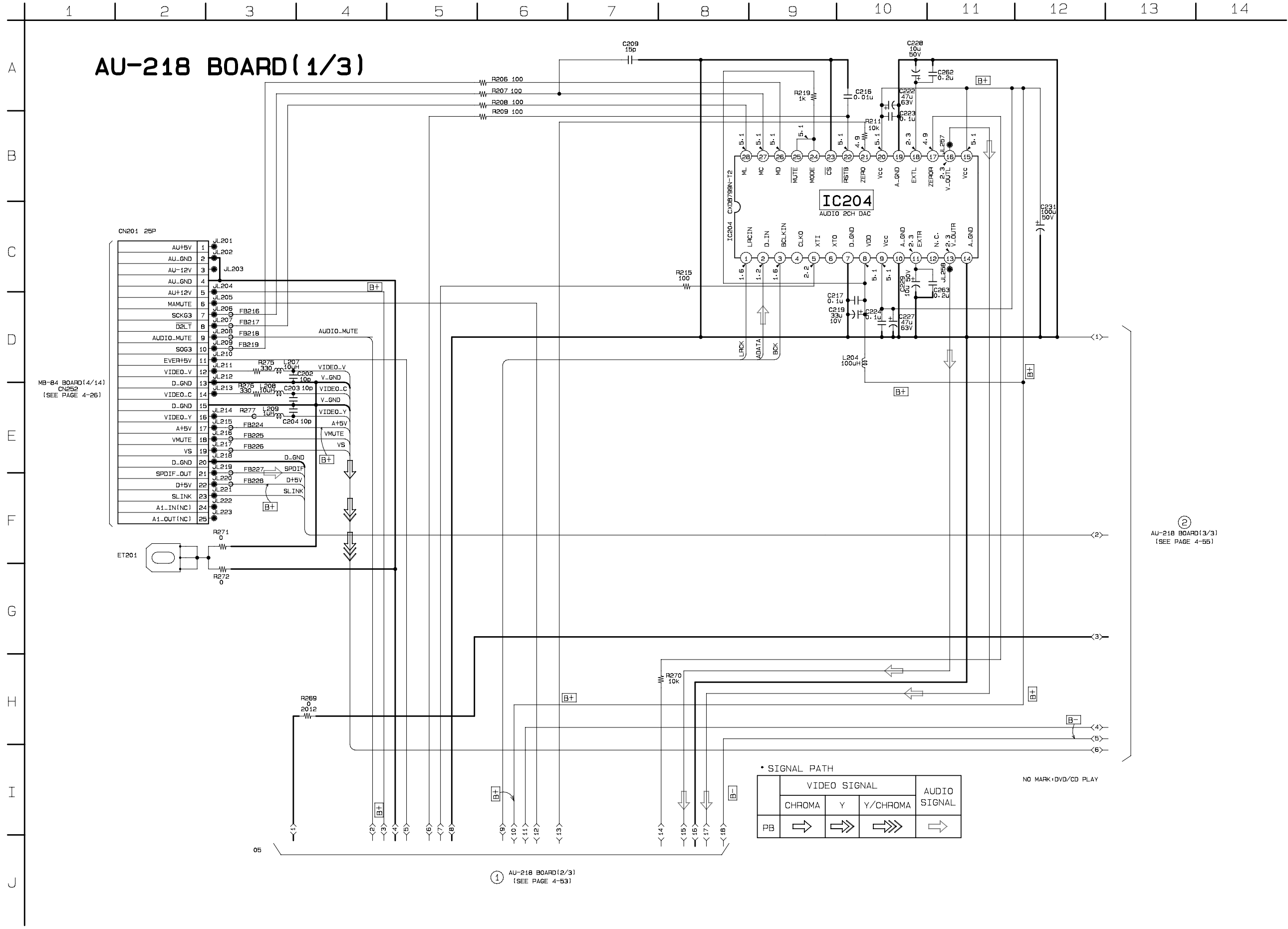


AU-218 BOARD (SIDE B)

CN201	C-4	IC206	B-7
CN203	C-8	IC207	B-4
CN204	B-9	IC208	B-1
CN205	C-1	IC209	B-2
		IC210	A-2
D201	C-8	Q201	B-8
D202	A-9	Q202	A-9
D203	A-9	Q203	B-5
D204	A-3	Q204	B-6
D205	A-3	Q205	B-8
D206	C-8	Q206	A-10
D207	A-3	Q207	A-10
D208	A-4	Q208	A-10
D209	C-8	Q209	B-7
D210	B-8	Q210	B-7
D211	B-8	Q211	B-5
D214	A-9	Q212	B-6
D215	B-9	Q213	A-7
D216	A-7	Q214	B-3
D352	A-1	Q215	B-3
		Q216	A-1
IC202	B-8	Q217	B-7
IC204	C-6		
IC205	A-8		

AU-218 (AUDIO 1) SCHEMATIC DIAGRAM • See page 4-47 to 4-50 for printed wiring board.

- Ref. No.: AU-218 board; 3,000 series -

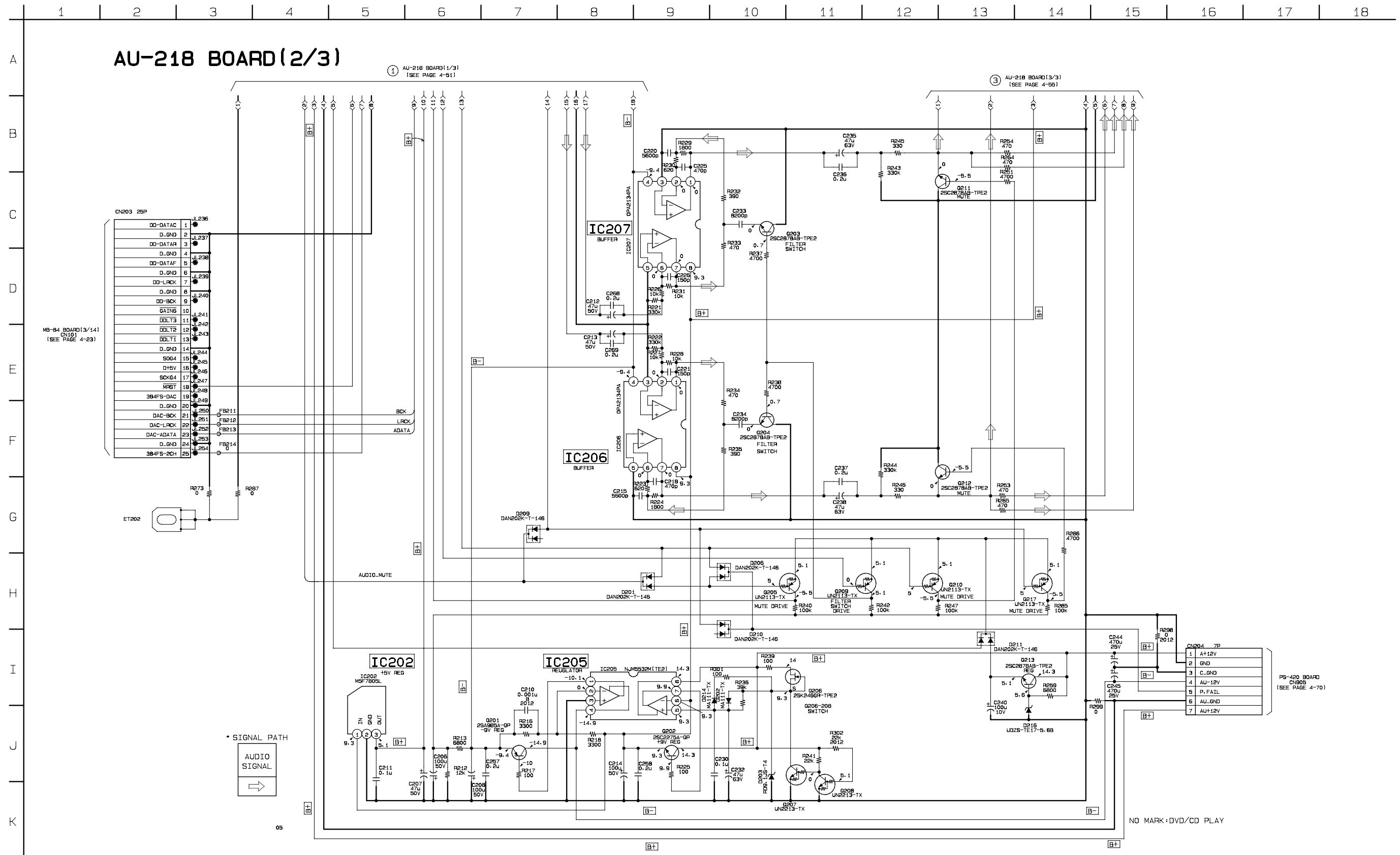


② AU-218 BOARD(3/3)  
(SEE PAGE 4-55)

① AU-218 BOARD(2/3)  
(SEE PAGE 4-53)

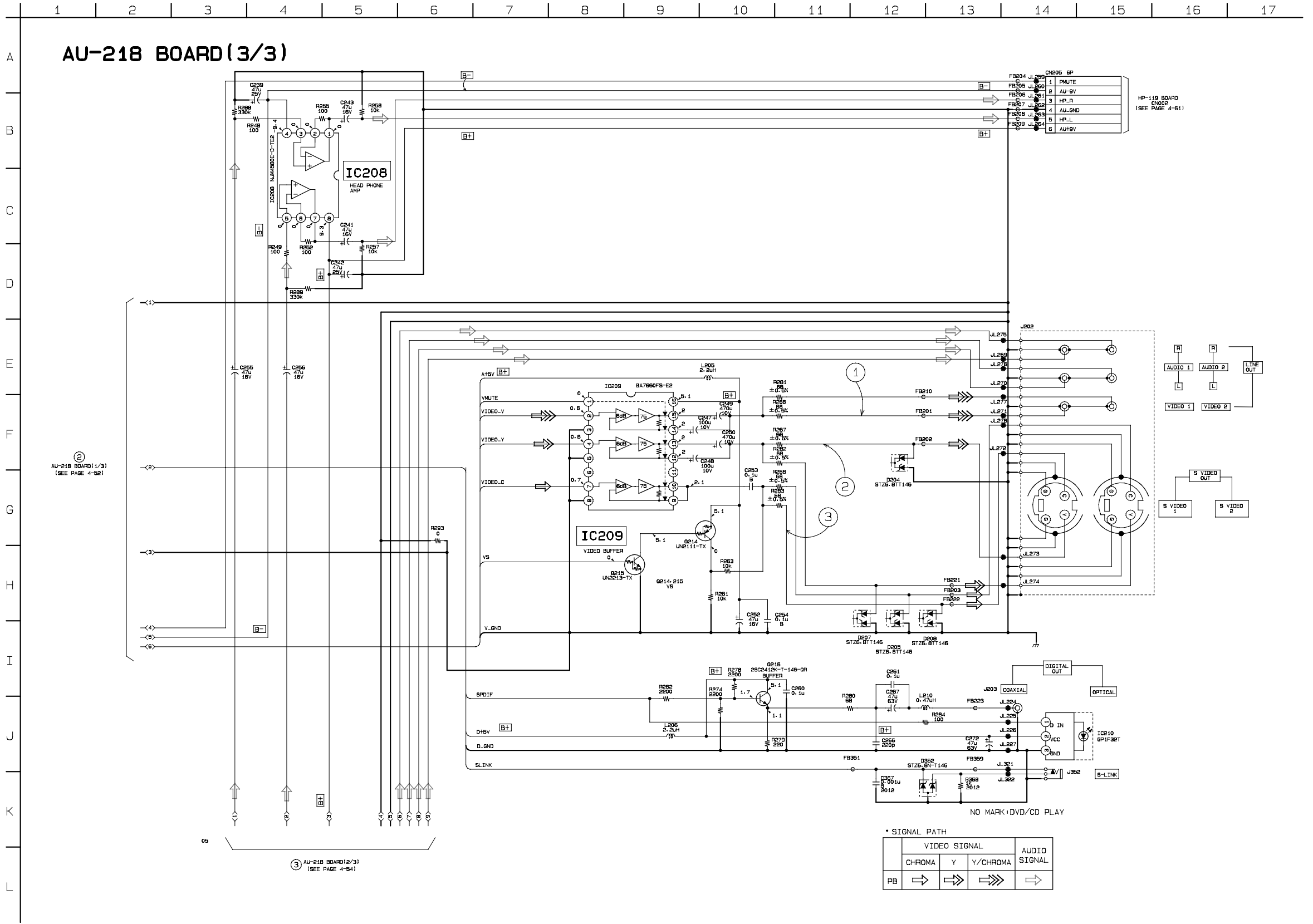
AU-218 (AUDIO 2) SCHEMATIC DIAGRAM • See page 4-47 to 4-50 for printed wiring board.

- Ref. No.: AU-218 board; 3,000 series -



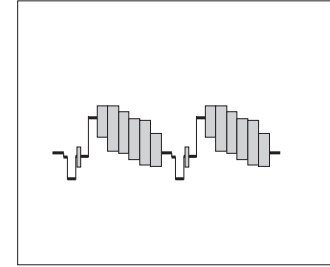
**AU-218 (VIDEO BUFFER) SCHEMATIC DIAGRAM** • See page 4-47 to 4-50 for printed wiring board.

– Ref. No.: AU-218 board; 3,000 series –



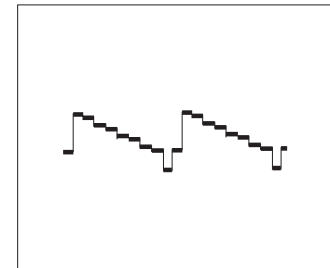
• Waveforms

1 IC209 15



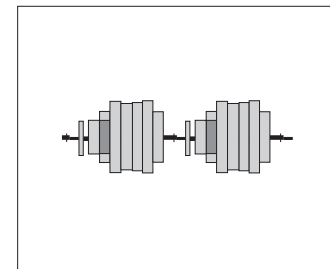
1.1 Vp-p (H)

2 IC209 13



1.0 Vp-p (H)

3 IC209 10



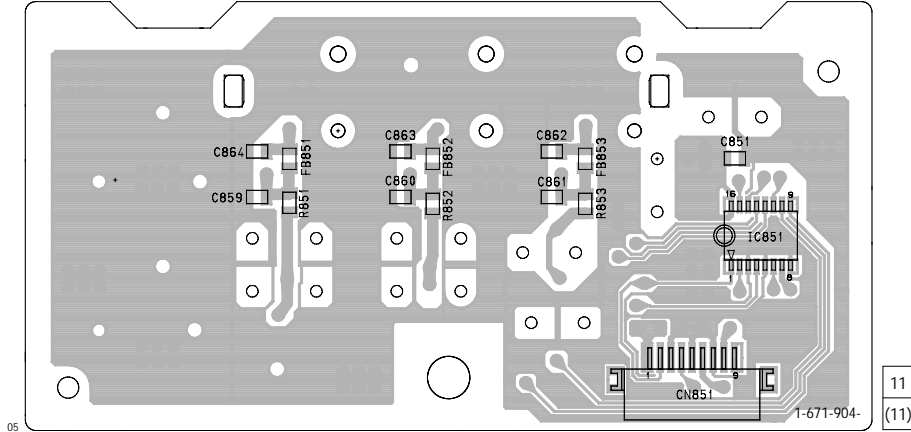
0.7 Vp-p (H)

**YS-18 (COMPONENT VIDEO) PRINTED WIRING BOARD AND SCHEMATIC DIAGRAM**

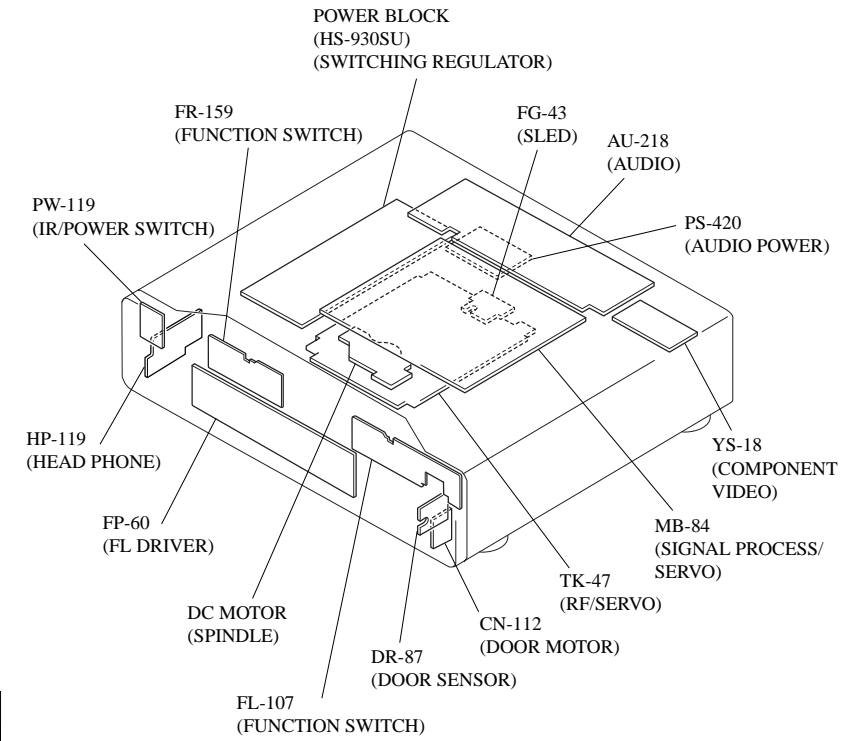
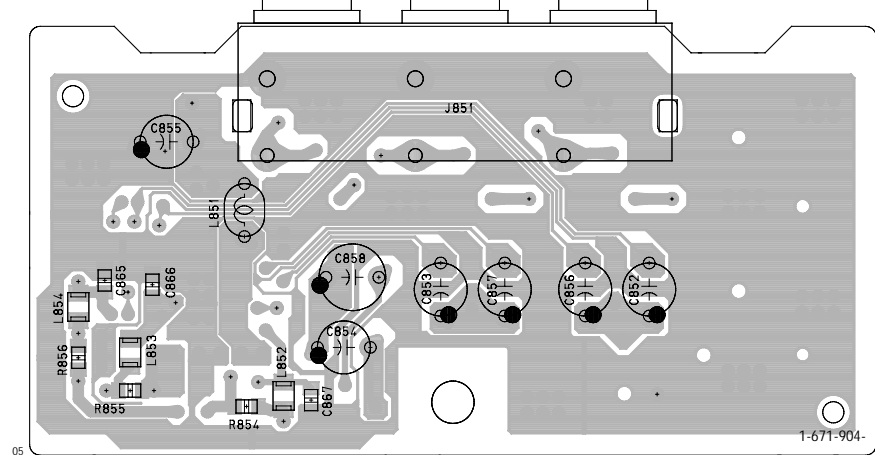
- Ref. No.: YS-18 board; 1,000 series -

There are few cases that the part isn't mounted in this model is printed on this diagram.

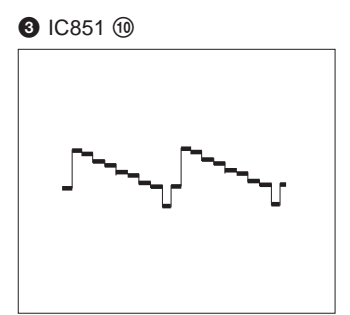
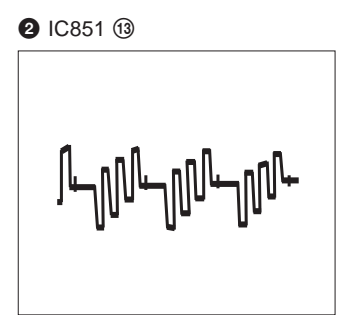
**YS-18 BOARD(SIDE A)**



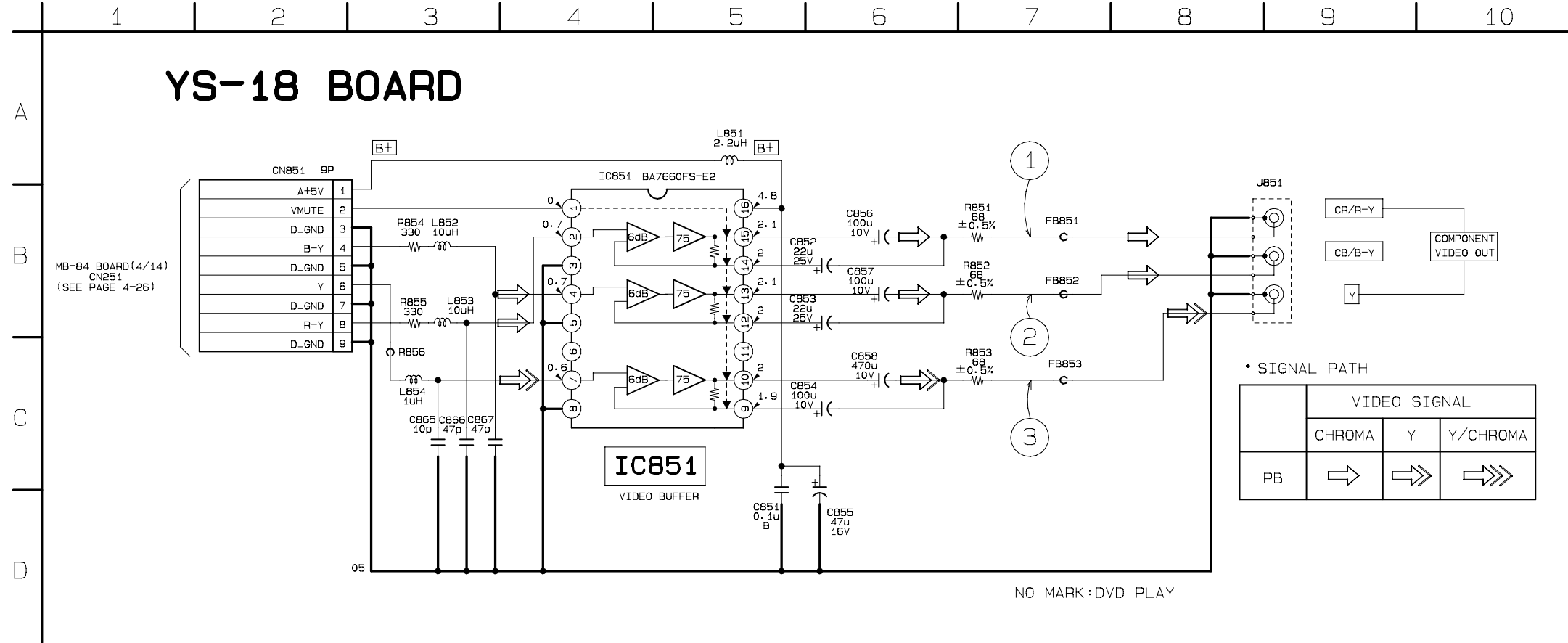
**YS-18 BOARD(SIDE B)**



**• Waveforms**



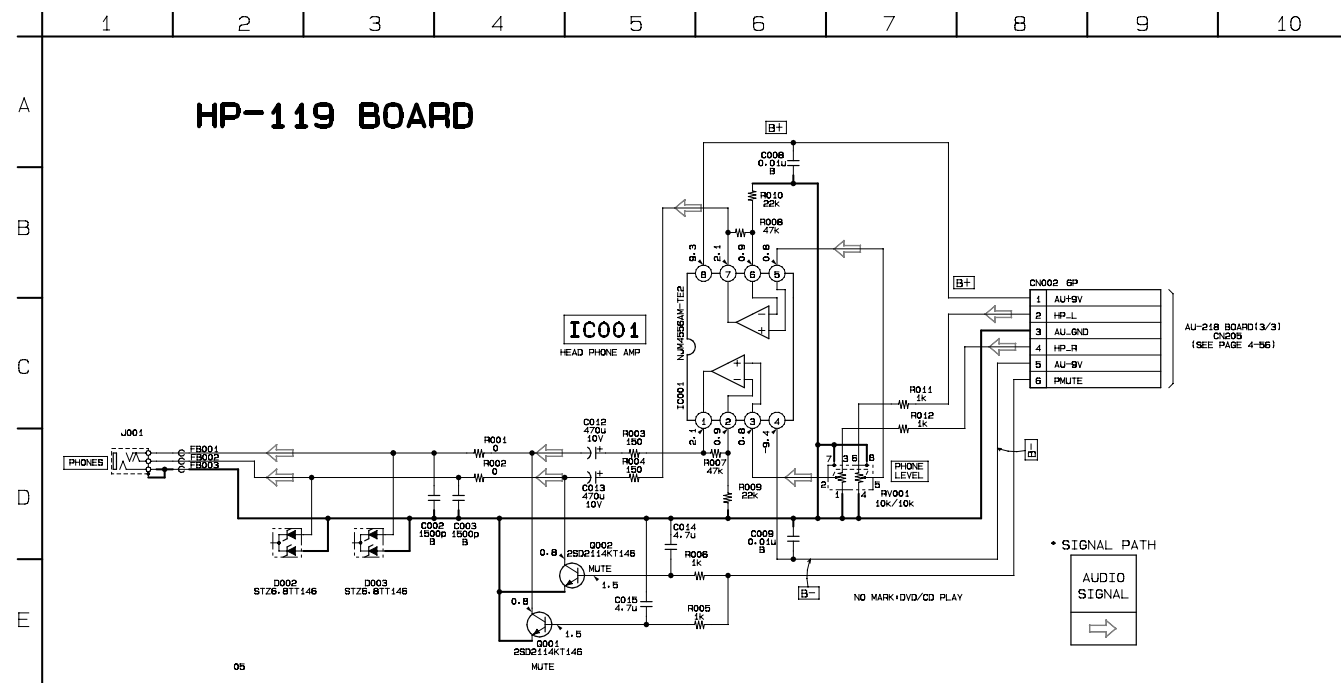
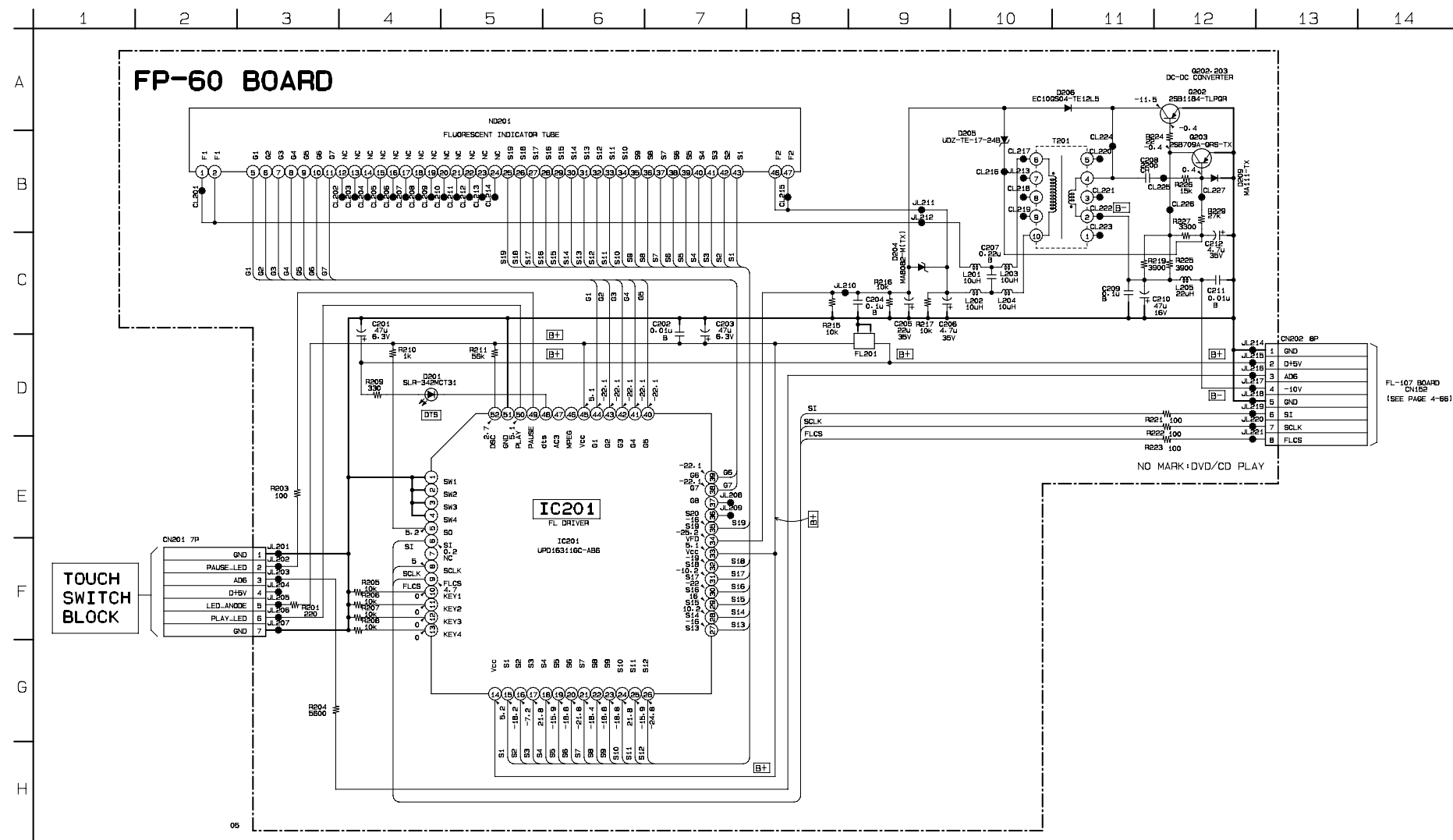
**YS-18 BOARD**





FP-60 (FL DRIVER), HP-119 (HEAD PHONE) SCHEMATIC DIAGRAMS

- Ref. No.: FP-60 board, HP-119 board; 1,000 series -



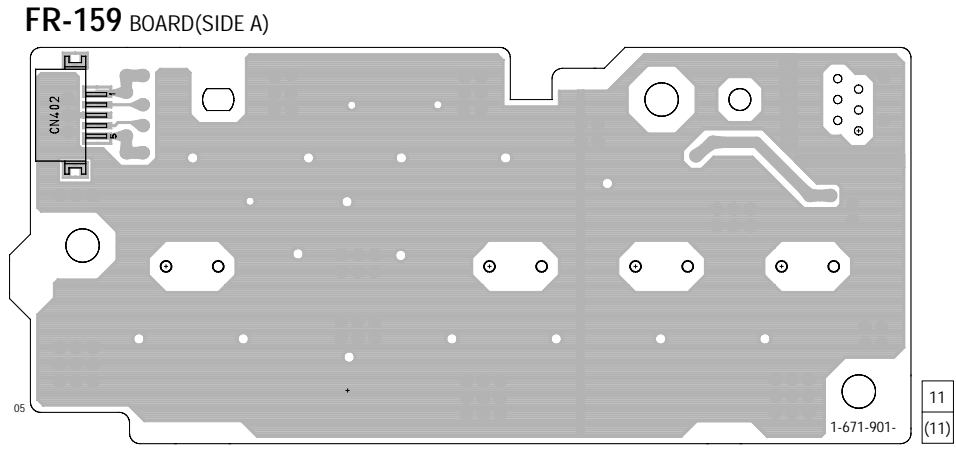


**DVP-S7700**

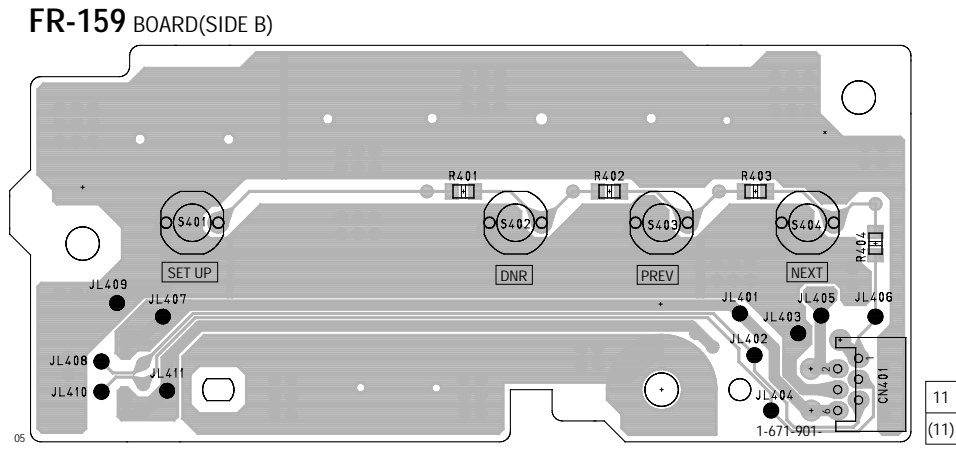
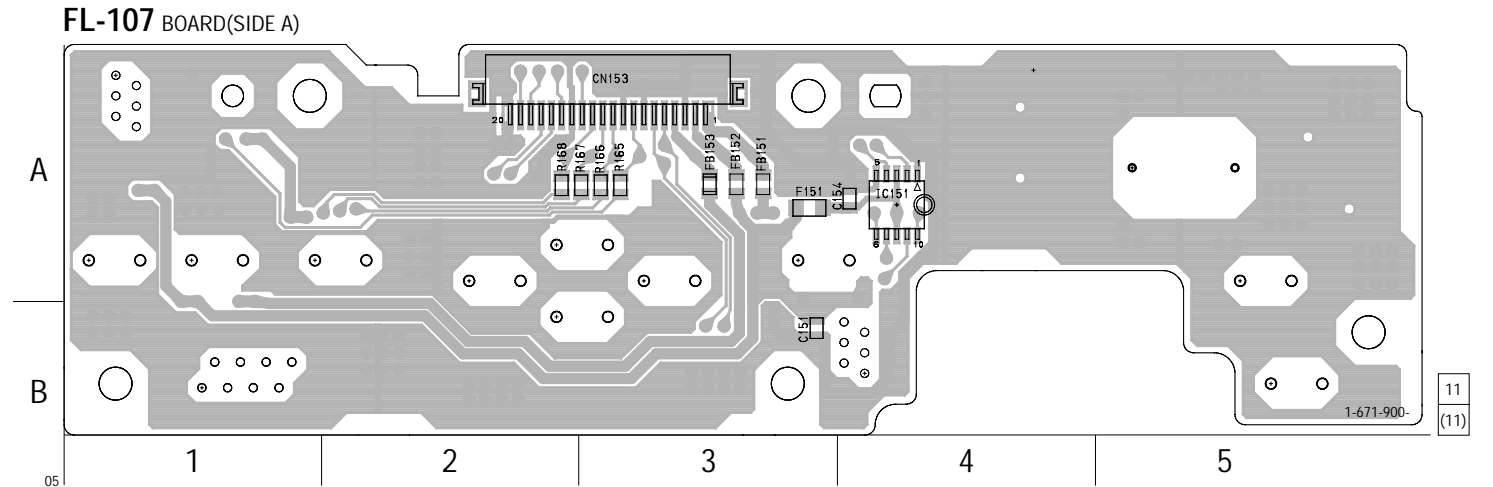
**CN-112 (DOOR MOTOR), DR-87 (DOOR SENSOR), FL-107 (FUNCTION SWITCH), FR-159 (FUNCTION SWITCH), PW-119 (IR/POWER SWITCH) PRINTED WIRING BOARDS**

- Ref. No.: CN-112 board, DR-87 board, FL-107 board, FR-159 board, PW-119 board; 1,000 series -

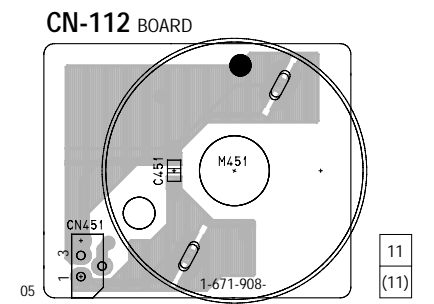
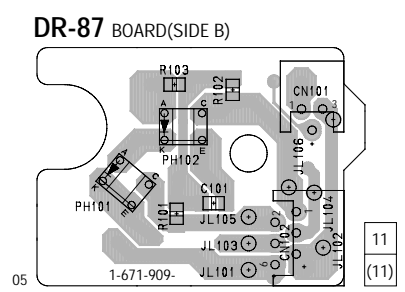
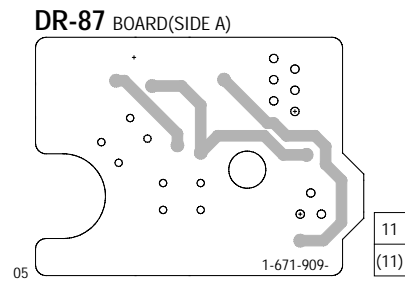
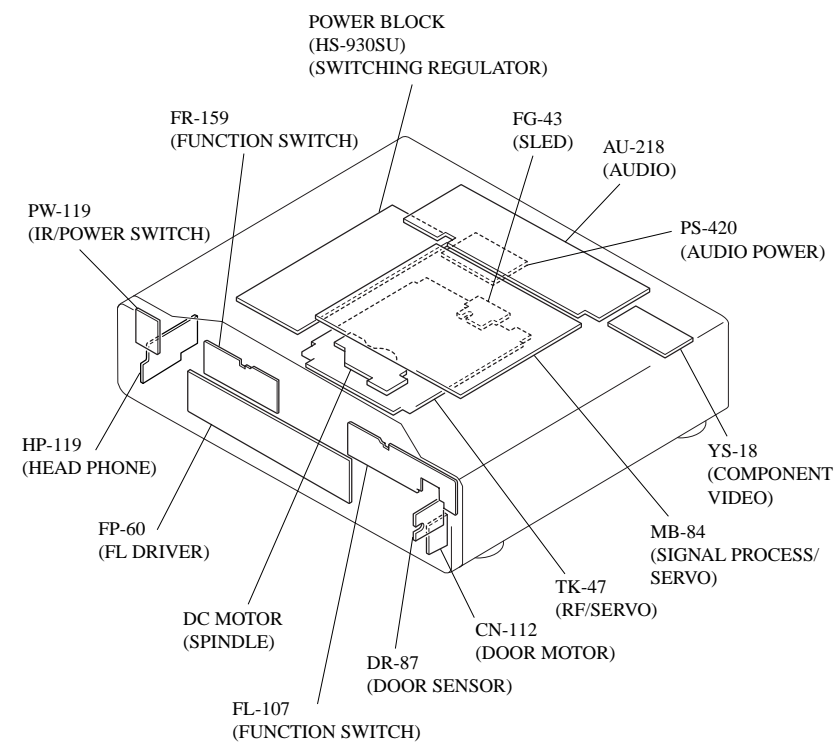
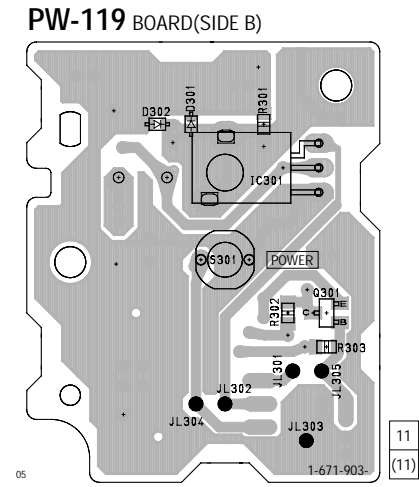
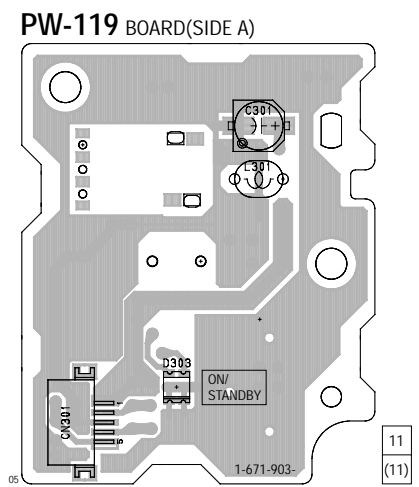
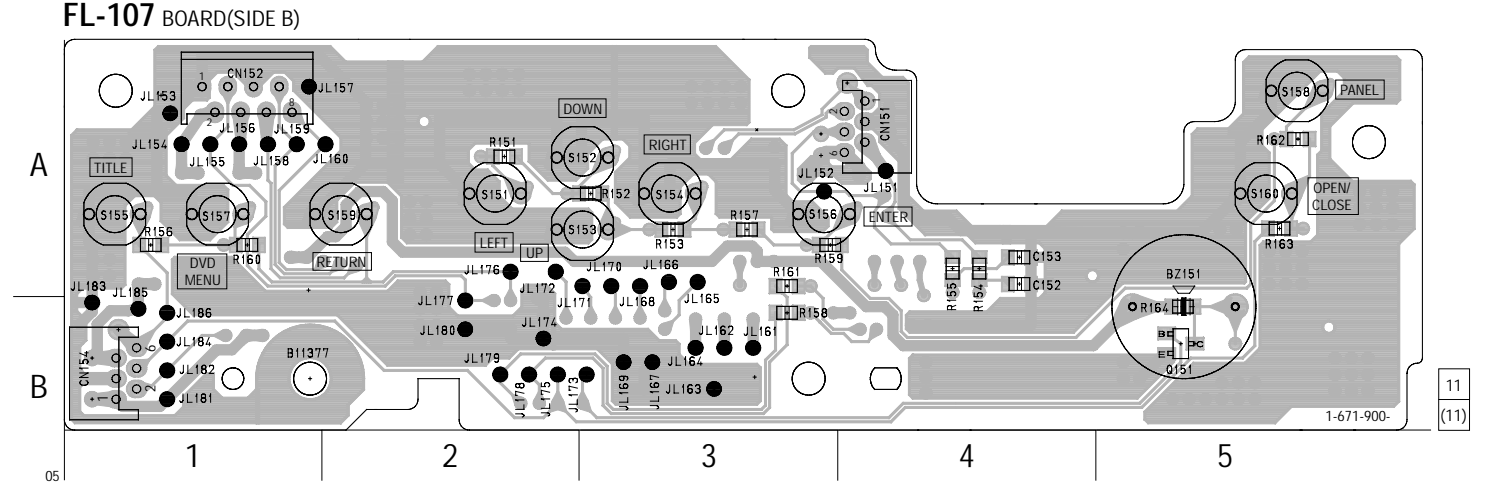
There are few cases that the part isn't mounted in this model is printed on this diagram.



- FL-107 BOARD (SIDE A)
- CN153 A-3
  - IC151 A-4



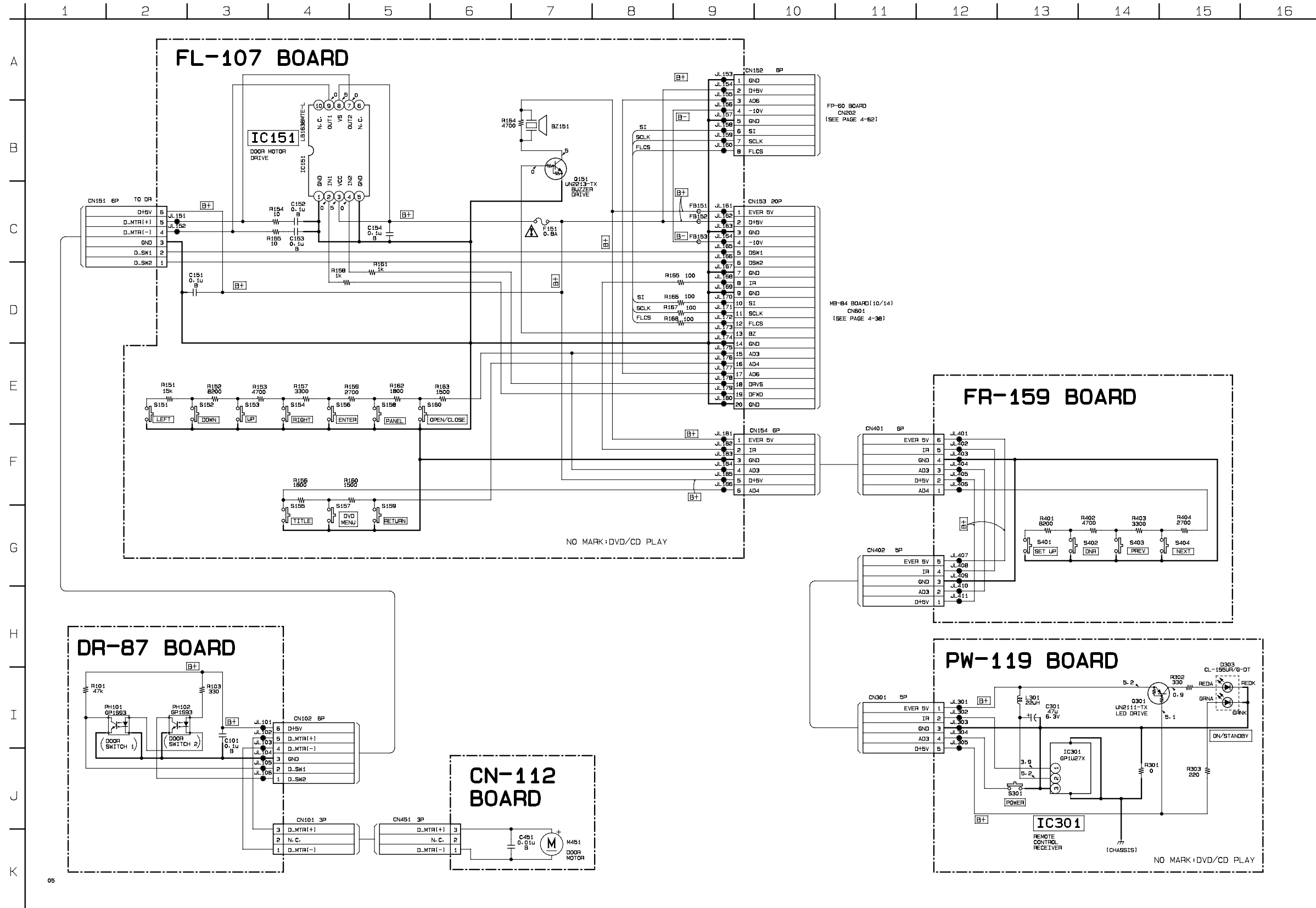
- FL-107 BOARD (SIDE B)
- CN151 A-4
  - CN152 A-1
  - CN154 B-1
  - Q151 B-5



**FUNCTION SWITCH, DOOR MOTOR  
CN-112, DR-87, FL-107, FR-159, PW-119**

CN-112 (DOOR MOTOR), DR-87 (DOOR SENSOR), FL-107 (FUNCTION SWITCH), FR-159 (FUNCTION SWITCH), PW-119 (IR/POWER SWITCH) SCHEMATIC DIAGRAMS

- Ref. No.: CN-112 board, DR-87 board, FL-107 board, FR-159 board, PW-119 board; 1,000 series -



**Note:**  
The components identified by mark  $\Delta$  or dotted line with mark  $\Delta$  are critical for safety. Replace only with part number specified.

**Note:**  
Les composants identifiés par une marque  $\Delta$  sont critiques pour la sécurité. Ne les remplacer que par une pièce portant le numéro spécifié.

FUNCTION SWITCH, DOOR MOTOR  
CN-112, DR-87, FL-107, FR-159, PW-119

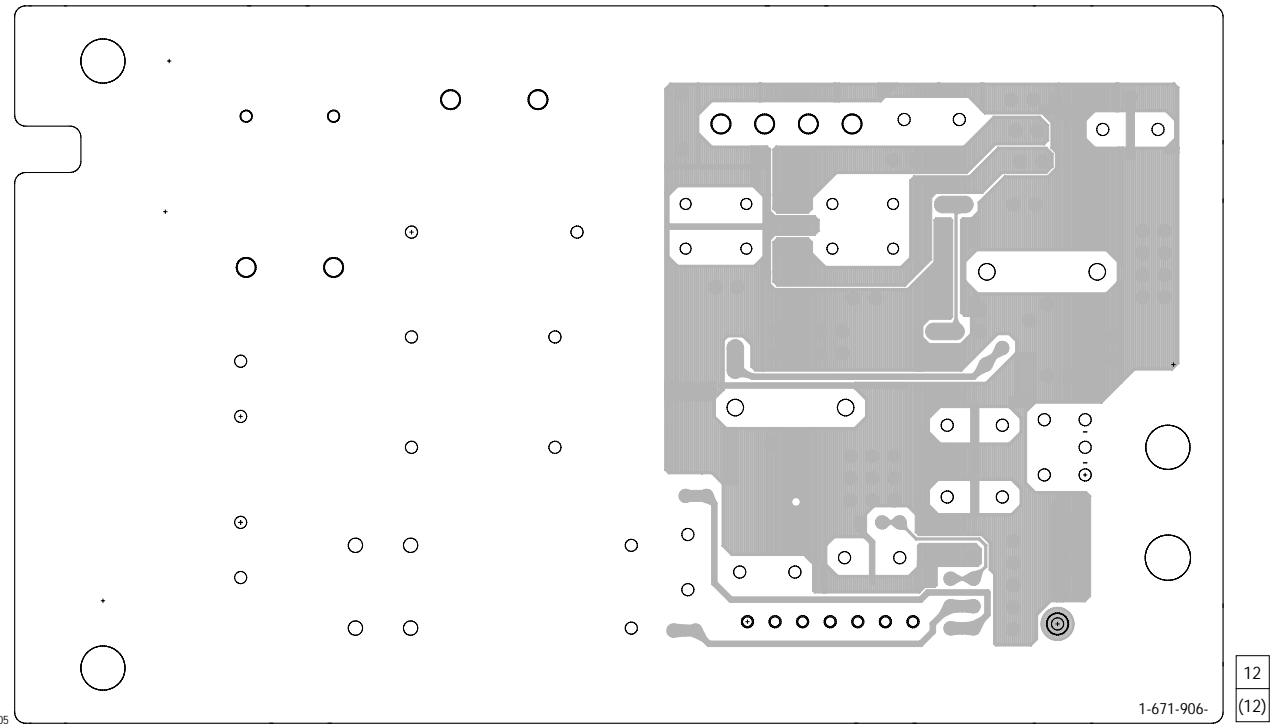
DVP-S7700

PS-420 (AUDIO POWER) PRINTED WIRING BOARD

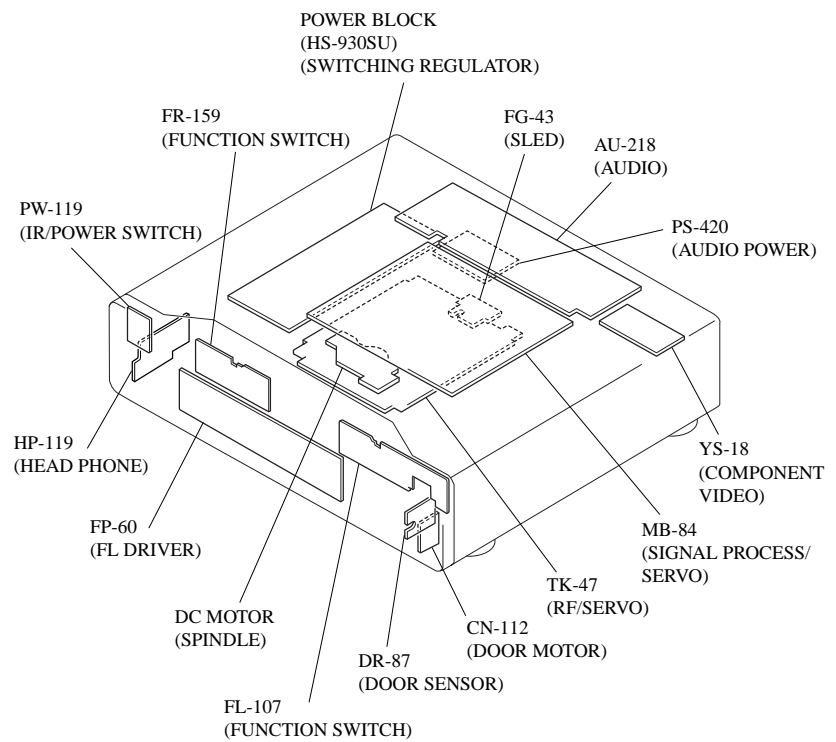
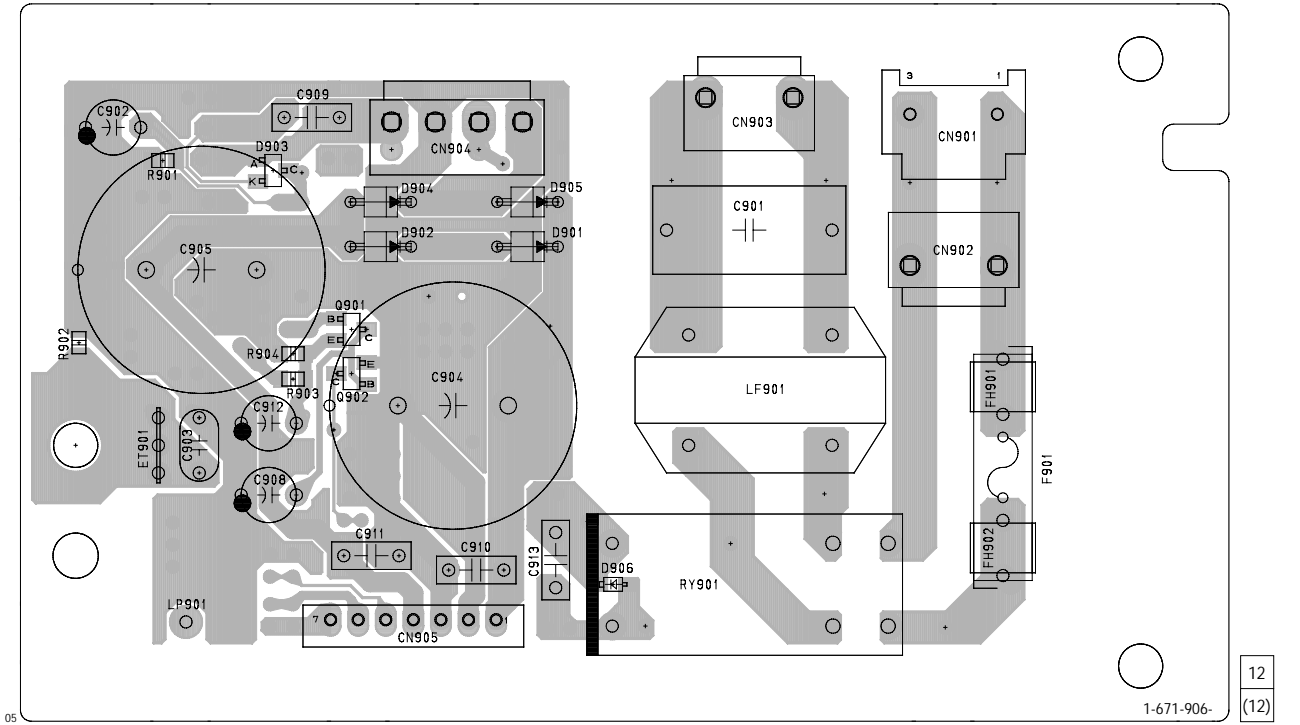
- Ref. No.: PS-420 board; 1,000 series -

There are few cases that the part isn't mounted in this model is printed on this diagram.

PS-420 BOARD(SIDE A)

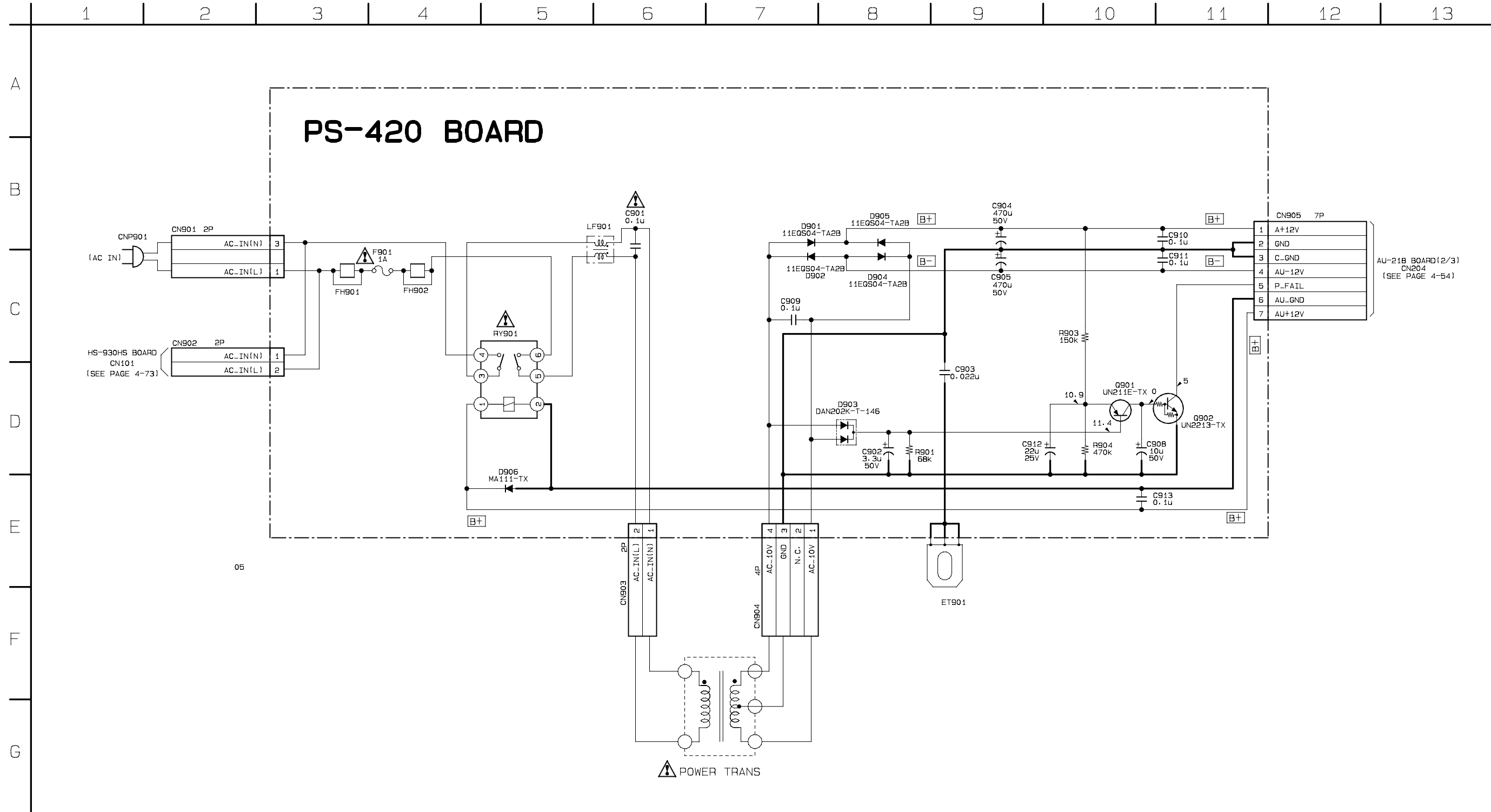


PS-420 BOARD(SIDE B)



**PS-420 (AUDIO POWER) SCHEMATIC DIAGRAM**

- Ref. No.: PS-420 board; 1,000 series -



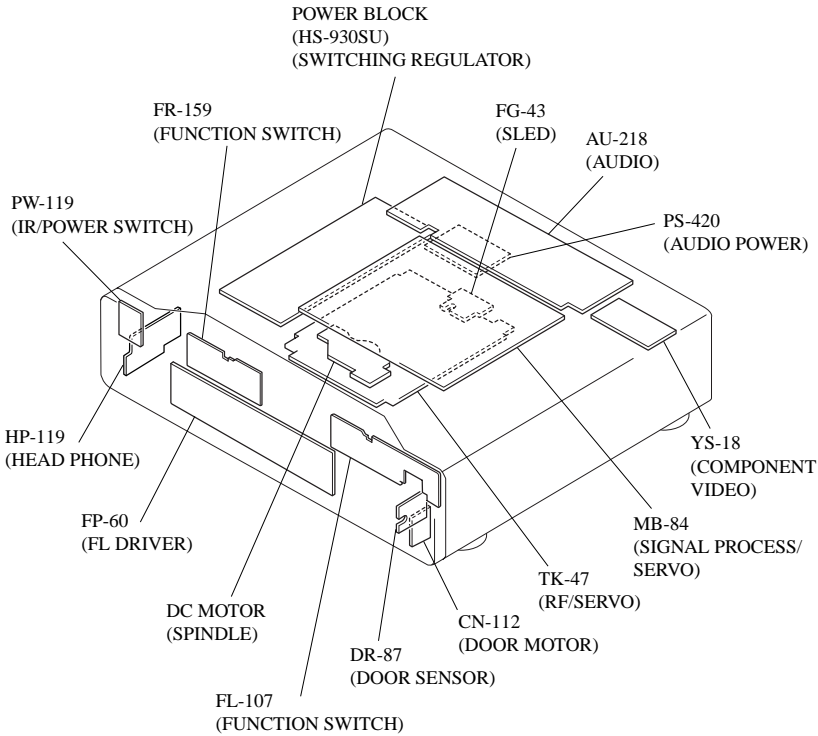
AU-218 BOARD(2/3)  
CN204  
(SEE PAGE 4-54)

<p><b>Note:</b> The components identified by mark <math>\triangle</math> or dotted line with mark <math>\triangle</math> are critical for safety. Replace only with part number specified.</p>	<p><b>Note:</b> Les composants identifiés par une marque <math>\triangle</math> sont critiques pour la sécurité. Ne les remplacer que par une pièce portant le numéro spécifié.</p>
--	---

**POWER BLOCK (HS-930SU) (SWITCHING REGULATOR) PRINTED WIRING BOARD**

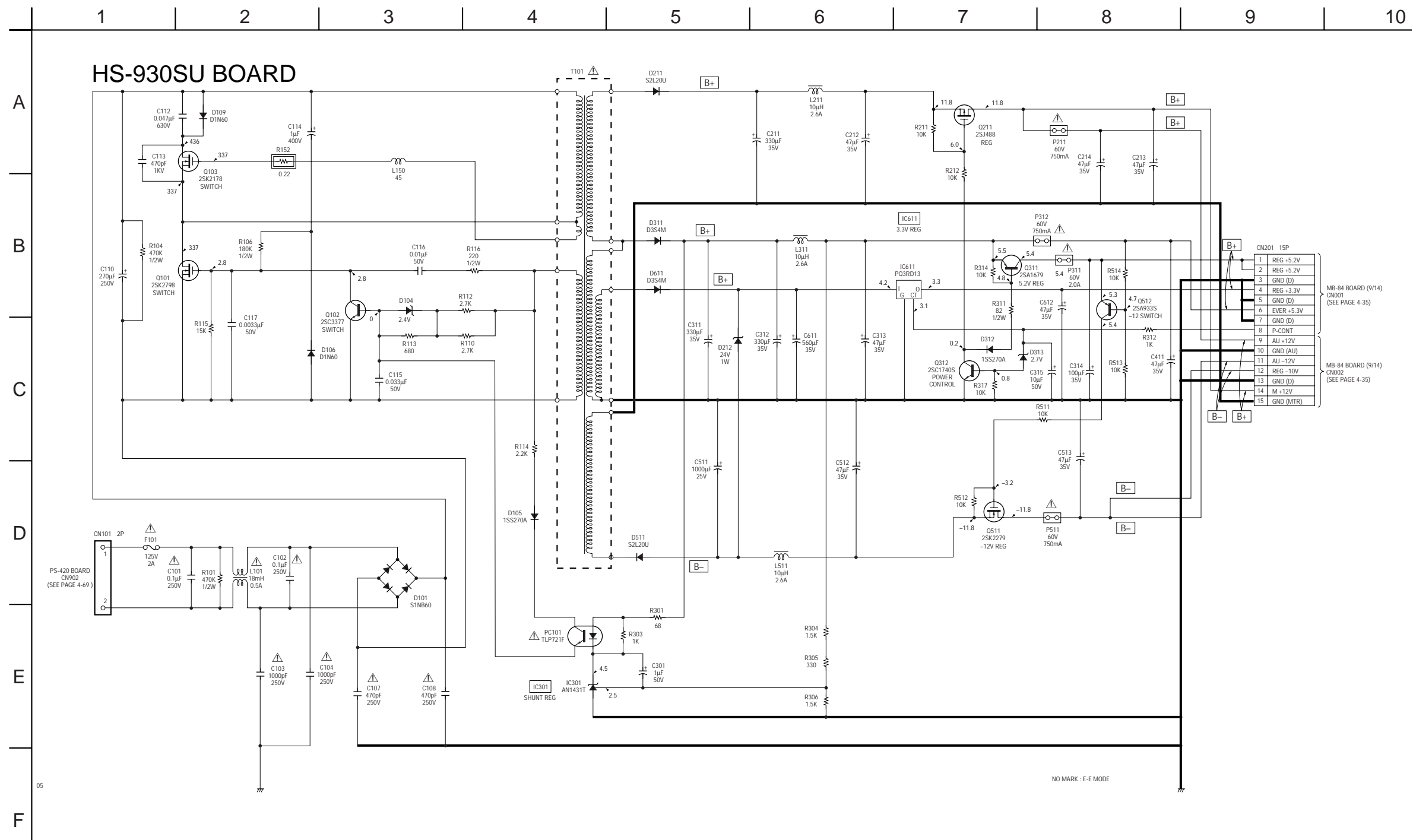
– Ref. No.: HS-930SU board; 4,000 series –

There are few cases that the part isn't mounted in this model is printed on this diagram.



**POWER BLOCK (HS-930SU) (SWITCHING REGULATOR) SCHEMATIC DIAGRAM**

– Ref. No.: HS-930SU board; 4,000 series –



**Note:**  
The components identified by mark  $\triangle$  or dotted line with mark  $\triangle$  are critical for safety. Replace only with part number specified.

**Note:**  
Les composants identifiés par une marque  $\triangle$  sont critiques pour la sécurité. Ne les remplacer que par une pièce portant le numéro spécifié.

## SECTION 5

### IC PIN FUNCTION DESCRIPTION

**5-1. INTERFACE CONTROL PIN FUNCTION (IC604 on MB-84 Board (10/14))**

Pin No.	Pin Name	I/O	Function	Pin No.	Pin Name	I/O	Function
1-4	A16-19	I/O	Set Address	40, 41	AD2, 3	I	Input of AD
5, 6	TIN0, 1	-	Not used	42	GND	-	GND
7, 8	TOT0, 1	-	Not used	43-46	AD4-7	I	Input of AD
9	ALE	O	Output of address latch inable signal	47	SDA	-	Not used
10	OE	O	Output of output inable signal	48	SCL	-	Not used
11	GND	-	GND	49-51	GND	-	GND
12	WRL	O	Output of write inable signal	52	HSTX	-	Not used
13	WRH	-	Not used	53	REF V	I	Input of V SYNC
14	HRQ	-	Not used	54	IFCS	I	Input of SH interrupt signal
15	HAK	-	Not used	55	ST-BY CONT	I	Input of ST-BY control signal
16	INTMS	I	Input of ready signal	56	INT3	-	Not used
17	CLK	-	Not used	57	CW	-	Not used
18	RX	I	Input of serialbus0	58	CCW	-	Not used
19	TX	O	Output of serialbus0	59	IR	I	Input of SJRCS
20	SCK	I/O	Serialbus0	60	A1 IN	-	Not used
21	SI	-	Not used	61	A1 OUT	-	Not used
22	SO	O	Output of serialbus1	62	DOT1	-	Not used
23	EVER 5V	-	Digital power supply	63	AC-3 OUT	-	Not used
24	SCLK	I/O	Serialbus1	64	STATUS	-	Not used
25	BZ	O	Output of buzzer	65-70	MODEL0-5	I/O	Model select1-6
26	AUDIO MUTE	O	Output of audio mute signal	71	1C	-	Not used
27	VIDEO MUTE	O	Output of video mute signal	72	ID	I/O	S-LINK status
28	CGGS	O	Output of charactor generator chipselect	73, 74	MIC IN 1, 2	-	Not used
29	FL2CS	-	Not used	75, 76	SW2, 3	-	Not used
30	FLCS	O	Output of FLCS	77	RESET IN	I	EXT RESET request
31	RESET	O	RESET	78-80	RCODE0	I/O	REGION set1-3
32	PPG6	I	Input DIAG	81	GND	-	GND
33	P:CONT	O	Output of POWER CONT signal	82	X OUT	O	Output of X'tal(4MHz)
34, 35	EVER 5V	-	Analog power supply	83	X IN	I	Input of X'tal(4MHz)
36, 37	GND	-	GND	84	EVER 5V	-	Analog power supply
38	MIC CONT	-	Not used	85-92	AD0-7	I/O	Address and data set
39	ECHO CONT	-	Not used	93-100	A8-15	I/O	Set address

5-2. SYSTEM CONTROL PIN FUNCTION (IC805 on MB-84 Board (13/14))

Pin No.	Pin Name	I/O	Function
1	PB14/IRQ6	I	Input of interrupt from IC506
2	PB15/IRQ7	I	Input of interrupt from IC804
3	VSS	-	Digital ground
4-11	AD0-7	I/O	Data bus AD0-7
12	VSS	-	Digital ground
13, 14	AD8, 9	I/O	Data bus AD8,9
15	VCC	-	Digital power supply
16-21	AD10-15	I/O	Data bus AD10-15
22	VSS	-	Digital ground
23-30	A0-7	O	Address bus A0-7
31	VSS	-	Digital ground
32-39	A8-15	O	Address bus A8-15
40	VSS	-	Digital ground
41, 42	A16, 17	O	Address bus A16,17
43	VCC	-	Digital power supply
44-47	A18-21	O	Address bus A18-21
48	CS0	O	Chip select signal for external ROM(IC803)
49	CS1	O	Chip select signal for external ROM(IC802)
50	CS2	-	Not used
51	CS3	-	Not used
52	VSS	-	Digital ground
53	PA0/CS4	O	Reset signal for IC101,209
54	PA1/CS5	O	Output of reset signal
55	PA2/CS6	O	Output of chip select signal to IC804
56	WAIT	I	Input of wait signal
57	WRL/WR	O	Output of write signal
58	WRH/LBS	-	Not used
59	RD	O	Output of read signal
60	PA7/BACK	O	Output of reset signal to IC508
61	VSS	-	Digital ground
62	PA8/BREQ	O	Output of reset signal to IC101
63	PA9	O	Output of reset signal to IC506
64	PA10	O	Output of A mute signal
65	PA11	O	Output of MA mute signal

Pin No.	Pin Name	I/O	Function
66	IRQ0	I	Input of interrupt from IC203
67	IRQ1	I	Input of DMA request from IC203
68	IRQ2	I	Input of V SYNC(FID) interrupt signal
69	IRQ3	I	Input of interrupt from IC804
70	VCC	-	Digital power supply
71	CK	O	Output of internal clock
72	VSS	-	Digital ground
73	EXTAL	-	20MHz crystal connection pin
74	XTAL	-	20MHz crystal connection pin
75	VCC	-	Digital power supply
76	NMI	I/O	Hyper terminal pin
77	VCC (Vpp)	-	Digital power supply
78	WDTOVF	-	Not used
79	RES	I	Input of reset signal
80	MD0	I	Input of mode select0 (fixed to 1)
81	MD1	I	Input of mode select1 (fixed to 0)
82	MD2	I	Input of mode select2 (fixed to 0)
83, 84	VCC	-	Digital power supply
85	AVCC	-	Analog power supply
86	AVREF	-	Reference power supply
87	PC0/AN0	I/O	Set of mode 1
88	PC1/AN1	I/O	Set of mode 2
89	PC2/AN2	I/O	Set of mode 3
90	PC3/AN3	I/O	Set of mode 4
91	AVSS	-	Analog ground
92	PC4/AN4	I/O	Set of mode 5
93	PC5/AN5	I/O	Set of mode 6
94	PC6/AN6	-	Not used
95	PC7/AN7	-	Not used
96	VSS	-	Digital ground
97	PB0	-	HFG
98	PB1	O	Output of reset signal for IC806
99	VCC	-	Digital power supply
100	PB2	-	Not used



Pin No.	Pin Name	I/O	Function
101	PB3	-	Not used
102	PB4	-	Not used
103	PB5	-	Not used
104	PB6	-	Not used
105	PB7	-	Not used
106	VSS	-	Digital ground
107	RxD0	I	Input of serial data
108	TxD0	O	Output of serial data
109	RxD1	I	Input of serial data
110	TxD1	O	Output of serial data
111	SCK0	O	Output of serial clock
112	SCK1	O	Output of serial clock

## SECTION 6 TEST MODE

### 6-1. Starting up Test Mode

With the DVP-S7700 turned off, press [TITLE], [CLEAR], and [POWER] keys on the Remocon in this order, and the Test mode will start up and the Test Mode Menu as shown in Figure 1 will appear on the video display.

```
Test Mode Menu
0. Syscon Diagnosis
1. Drive Auto Adjustment
2. Drive Manual Operation
3. Mecha Aging
4. Emergency History
5. Other Checks
Exit: POWER key
```

**Figure 1**

In the Test mode, use all keys on the Remocon or operation panel when performing necessary operation. In any menu except during test with the Syscon Diagnosis menu, press the [POWER] key to exit from the Test mode, and return to the power off status.

Pressing [0] key on the Remocon during display of this initial menu activates the Diagnosis mode and the screen as shown in Figure 2 appears.

```
Syscon Diagnosis
IF con Ver.
SYScon Ver.
Model No. DPX11????
** Press Remocon Key **
SIRCS:FF KEY:FF
```

→IFcon version (checksum)  
→Syscon version (checksum)  
(checksum of Syscon is initially 0000)  
→Model code

**Figure 2**

### 6-2. Selection of Check Item

A check item can be selected when Model No. is displayed. Press numeric keys to check the selected item, or any key other than numeric keys to check all items.

#### 6-2-1. Selected Item Check

As the menu is not displayed, select the number from the list, and enter 2-digit main item No. and 2-digit sub item No. using numeric keys on the Remocon. When the first one digit is entered, the item selection screen is displayed. Then, enter remaining three digits and press [ENTER] key.

When an item is selected, the detail check is executed where in the case of RAM check, all addresses are checked twice by changing the data.

<Example> Select 2-2 ROM Check.

As item No. is <2-2>, enter "0202".

```
Syscon Diagnosis
IF con Ver. 0.620 (9315)
SYScon Ver. 0.400 (0000)
Select Diag No. ; 0 -
** Press Remocon Key **
SIRCS:FF KEY:FF
```

→Enter item No.[0]

**Figure 3**

```
Syscon Diagnosis
IF con Ver. 0.620 (9315)
SYScon Ver. 0.400 (0000)
Select Sub No. ; 02 -
** Press Remocon Key **
SIRCS:FF KEY:FF
```

→Enter item No.[02]

**Figure 4**

```
Syscon Diagnosis
IF con Ver. 0.620 (9315)
SYScon Ver. 0.400 (0000)
Select Sub No. ; 02 - 0
** Press Remocon Key **
SIRCS:FF KEY:FF
```

→Enter item No.[02-0]

**Figure 5**

```
Syscon Diagnosis
IF con Ver. 0.620 (9315)
SYScon Ver. 0.400 (0000)
Press Enter ; 02 - 02
** Press Remocon Key **
SIRCS:FF KEY:FF
```

→Enter item No.[02-02]

**Figure 6**

Up to here, the [CLEAR] key can be used. Pressing [CLEAR] key clears the selected number, and selection can be retried from the beginning. If [ENTER] key is pressed, the diagnosis of only the selected number is executed, and the result is displayed.

If any key is pressed while the result display is blinking, the screen returns to the initial Test Mode Menu screen. Where visual check is necessary such as a still picture check, or when an error occurred, use [PREV] key for repeated checking. To go to the next step, press [NEXT] key.

If the diagnosis of selected number does not exist, the initial screen is restored when [ENTER] key is pressed.

#### 6-2-2. All Items Check

Press any key other than numeric keys when Model No. is displayed to activate the all items check mode. In the all items check mode, RAM check is simplified. In concrete, only the skipped blocks such as 0-ff, 500-5ff, a00-aff, f00-fff, 1400-14ff, ... (addresses) are checked. Check is executed from the top item of the diagnosis check items list sequentially. In a checking where visual check is not necessary, check progresses to the next item automatically unless an error occurs.

In case of an error or visual check is necessary, press [PREV] key, and the item concerned is repeatedly checked. To go to the next item, press [NEXT] key.

## 6-3. Error Display

In case of an error, the error code and information are displayed as shown in Figure 7.

Syscon Diagnosis	
IF con Ver. 0.620 (9315)	
SYScon Ver. 0.400 (62ED)	
RAM Check	→Check item name
Error Code: 05	→Error code
Address : 01001D87	→Address where error occurred
Write Data: 20	→Written data (2 – 8 digits)
Read Data: FF	→Read data (2 – 8 digits)
SIRCS:FF KEY:FF	

Figure 7

When the Error Code is other than “05” (write/read data mismatch error), the Address and Data become “0”.

“Diag OK” or “Diag Error End” message blinks, when the check is all finished or stopped. Press a key here, and the screen returns to the initial Test Mode Menu screen.

## 6-4. General Description of Checking Method

This section describes briefly a checking method of each diagnosis item, following the order of menu.

The number in ( ) in each item indicates a diagnosis item number.

### (2) Memory

#### (2-2) Syscon ROM (IC803) Check

Checksum calculation

Error: Not detected

At addresses from 0x00000 to 0xfffff of Syscon ROM (IC803), checksum is calculated by adding 8-bit data, and the result is displayed with 4-digit number in hexadecimal notation. As the error is not detected, compare the displayed result with original ROM checksum.

#### (2-3) Syscon RAM (IC802) Check (DMA used)

Syscon ROM (IC803) → Syscon RAM (IC802) matching check

Error 05: Write/read data mismatch error

External RAM (IC802) of IC805 (Syscon) is saved in the stack by 256 bytes each, and ROM data are transferred to the DMA. Then, the data are compared with ROM (IC803) data every byte. In detail check, the bit inverted data are further written, and rechecked. During checking, all interruptions are stopped. Also, variables use only the stacks including save area and bit inverted buffer. As a processing is executed in the closed circuits within this function, the data transfer to stack area also uses the DMA. In the detail check, all areas of external RAM (IC802) are checked twice by inverting the data, but in the simple check, one block is checked, then the subsequent 4 blocks are skipped, and also a check of inverted data is not executed.

If write/read mismatch error occurred, checking can be repeated.

### (3) Destination Setting

#### (3-2) Destination setting Check

I/O port read

Error: Not detected

The destination setting port (I/O) is read, and displayed with hex. number.

Error is not detected.

#### (4) Gate Array (62000CFh: Peripheral Access Control)

##### (4-2) Register

Write data → Read data matching check

Error 05: Write/read data mismatch error

Register at adrs=62000CFh (Peripheral Access Control)

Whether written data and read data are matched is checked.

If write/read mismatch error occurred, checking can be repeated.

##### (4-3) Reset Line

Write → Hard reset → Read

Error 02: Reset error

0xff is written to the register (Peripheral Access Control) at adrs=62000CFh, and whether it is initialized to “0x00” by the reset pulse is checked.

### (5) Drive

#### (5-2) EEPROM (serial) (IC801)

Data write → Read matching check

Error 05: Write/read data mismatch error

11: Serial transfer error

12: EEPROM not ready

16-bit data is written to the address 0 of EEPROM (IC801), and it is read to check for matching. Before checking, the content of address 0 is read for saving, but if it cannot be read, the error is displayed and operation is terminated, and data writing is not executed.

In this diagnosis, 16-bit data is checked. 16 kinds of patterns are written by shifting 1 bit each from 0x0001 toward the left.

If write/read mismatch error occurred, checking can be repeated. Even if an error occurs after write/read check started, the saved data are written when this diagnosis is quitted, but whether data are written correctly is not guaranteed.

#### (5-3) SSI (Serial)

Serial register write → Register read matching check

Error 05: Write/read data mismatch error

33: SSI serial transfer error

0x00 – 0xff data are written to the FCCR register for SSI, then they are read to check for matching.

If write/read mismatch error occurred, checking can be repeated.

#### (5-4) Servo DSP (IC506) Download

DSP (IC506) code area ROM/RAM discrimination  
RAM: Program download → Revision data read  
ROM: Revision data read

Error 04: Data read error  
13: DSP (IC506) data not ready

For the Mask ROM, no download can be executed. Download is possible for the RAM only. ROM/RAM is discriminated by the DBUSY signal of DSP (IC506) pin ④ after hardware reset. The diagnosis provides exclusive download flag.

For this flag, download not executed : 0  
download already executed : 1  
download error : 2

ROM/RAM is discriminated by the status of DBUSY signal after hardware reset. If RAM, the servo control code is downloaded.

If no error is found, the version No. is read from address:200, and displayed.

If ROM, the version No. is read from address:200 immediately. Compare displayed data with existing data.

If RAM, "DSP Download Rev.=xxxx" is displayed.

If ROM, "DSP Mask ROM Rev.=xxxx" is displayed.

#### (5-5) Servo DSP Register

(Program download) → Data write → Read matching check

Error 04: Data read error  
05: Write/read data mismatch error  
13: DSP (IC506) data not ready  
14: DSP (IC506) download error

The download flag is checked, and if 0, the program is downloaded. However, in the case of ROM, it is not downloaded.

Unless download error occurs, the content of address 200h of DSP (IC506) is read for saving, then checking starts. In this check, 16 kinds of patterns are written to the address 200h by shifting 1 bit each from 0x0001 toward the left, then they are read.

If write/read mismatch error occurred, checking can be repeated.

#### (5-6) Servo DSP (IC506) Reset Line

Register write → Hard reset → Register read

Error 02: Reset error  
13: DSP (IC506) data not ready  
14: DSP (IC506) download error

In the case of RAM, this diagnosis checks that the register cannot be read after hardware reset. Unless download error occurs, the content of address 200h of DSP (IC506) is read, and after hardware reset, the data is read again for comparison.

The check results in OK, if the register cannot be read, or data are not matched even if it can be read. The reset error occurs if read data are same as that before hardware reset.

In the case of ROM, whether the version No. is initialized by the reset is checked. First, the version No. is read, then its complement is written.

After hardware reset, the data is read again and if it matches the written data, the reset error occurs.

#### (6) Data Source

##### (6-2) Register in ARP (IC806)

Register write → Register read matching check

Error 05: Write/read data mismatch error

Data from "0x00" up to "0xff" are written to 12 registers where all bits can be written and read, then read to check for matching. If write/read mismatch error occurred, checking can be repeated.

##### (6-3) Reset Line in ARP (IC806)

Register write → Hard reset → Register read

Error 02: Reset error  
05: Write/read data mismatch error

After "0xfe" is written to the INTEN3 register, whether it is initialized to "0x00" by the reset pulse signal is checked.

To make sure, the written data is read to check for matching before reset is executed.

##### (6-4) DRAM (IC810) in ARP

ROM data → ARP (IC806) → DRAM (IC810) → ARP (IC806)  
read matching check

Error 03: Data write error (ARP (IC806) is not enabled for data writing)  
04: Data read error (ARP (IC806) is not enabled for data reading)  
05: Write/read data mismatch error

ROM (IC803) patterns are copied to all areas to be checked. Each time 256 bytes are copied, the addresses of copy source (ROM) are returned by 254 bytes. In detail check, all areas are checked to verify all bits in DRAM (IC810), then the inverted data are further checked in the same manner. The bus width of ARP (IC806) is 16 bits. This check program displays addresses in 16 bits.

Overwriting by the shadow can be detected, as the data are written to all areas, then read. In the detail check, all areas of RAM (IC802) are checked twice by inverting the data, while in the simple check one block is checked, then subsequent 4 blocks are skipped, and also inverted data are not checked.

If write/read mismatch error occurred, checking can be repeated.

##### (6-5) Interrupt Line in ARP (IC806)

Data transfer request → Data transfer stop interruption from ARP (IC806)

Error 21: ARP (IC806) interruption is not detected

AC-3 audio data stored in ROM (IC803) are transferred to the ARP (IC806), then the designated sector data output stop interruption from ARP (IC806) is detected.

To discriminate the Decrypt (IC811) interruption which is also sent in the same line, the Decrypt (IC811) interruption is all masked.

#### (6-6) Register in Decrypt IC (IC811)

Register write → Register read matching check

Error 05: Write/read data mismatch error

0x00 – 0xfc data (lower 2 bits are masked) are written to the interrupt register, then read to check for matching.

If write/read mismatch error occurred, checking can be repeated.

#### (6-7) Reset of Decrypt IC (IC811)

Register write → Hard reset → Register read

Error 02: Reset error

05: Write/read data mismatch error

After “0xfc” is written to the interrupt register, whether it is initialized to “0x00” by the reset pulse signal is checked.

To make sure, the written data is read to check for matching before reset is executed.

#### (6-8) Interrupt Line in Decrypt IC (IC811)

ROM (IC803) → ARP (IC806) → Decrypt (IC811)

Error 22: Decrypt (IC811) interruption is not detected

AC-3 audio data stored in ROM (IC803) are transferred to the Decrypt via ARP (IC806), then the reserved data interruption from Decrypt (IC811) is detected.

To discriminate the ARP (IC806) interruption which is also sent in the same line, the ARP (IC806) interruption is allmasked.

#### (6-9) Reserved Data Head Byte Reading

ROM (IC803) → ARP (IC806) → Decrypt (IC811) reserved data head byte read matching check

Error 05: Write/read data mismatch error

22: Decrypt (IC811) interruption is not detected

AC-3 audio data stored in ROM (IC803) are transferred to the Decrypt via ARP (IC806), then the reserved data head bytes are read from Decrypt (IC811) register.

As this audio data consists of 5 sectors, 0, 1, 2, 3, 4 data are written at the head of reserved data of respective sectors.

Whether these data are matched is checked through every sector interruption.

If write/read mismatch error occurred, checking can be repeated.

#### (7) AV Decoder (IC203)

##### (7-2) Register in AV Decoder (IC203)

Register write → Register read matching check

Error 05: Write/read data mismatch error

“0x00” – “0xff” data are written to 51 registers where all bits can be written/read, then they are read to check for matching.

If write/read mismatch error occurred, checking can be repeated.

##### (7-3) Reset Line in AV Decoder (IC203)

Register write → Hard reset → Register read matching check

Error 02: Reset error

05: Write/read data mismatch error

After “0xff” is written to the Capture/Compare Control Register 0, whether it is initialized to “0x00” by the reset pulse signal is checked.

To make sure, the written data is read to check for matching before reset is executed.

##### (7-4) DREQ Signal Line in AV Decoder (IC203)

AV Decoder (IC203) DMA check

Error 03: Data write error

04: Data read error

05: Write/read data mismatch error

06: DMA transfer DREQ error

07: DMA transfer address error

The connection of DREQ signal line to the AV Decoder (IC203) is checked through DMA transfer.

If no error is found in DMA transfer, the transferred data are compared with the DRAM (IC810) data read from the register.

##### (7-5) DRAM in AV Decoder (IC203)

ROM data → AV Decoder (IC203) → DRAM (IC810) → AV Decoder (IC203) read matching check

Error 03: Data write error

04: Data read error

05: Write/read data mismatch error

06: DMA transfer DREQ error

07: DMA transfer address error

ROM (IC803) patterns are copied to all areas to be checked. Because of large DRAM (IC810) capacity, each time 256 bytes are copied, the addresses of copy source (ROM) are returned by 255 bytes. In detail check, to verify all bits in DRAM (IC810), the bit patterns are checked again after inversion. DMA is used when writing/reading the data. Though the bus width of AV Decoder (IC203) is 64 bits, the display is given in 8 bits. Namely, actual address is 1/8 of displayed data, and lower 3 bits indicate the byte position.

Overwriting by the shadow can be detected, as the data are written to all areas, then read. In the detail check, all areas of RAM are checked twice by inverting the data, while in the simple check one block is checked, then subsequent 4 blocks are skipped, and also inverted data are not checked.

If write/read mismatch error occurred, checking can be repeated.

#### (7-6) Connection from ARP (IC806) to AV Decoder (IC203)

ROM data → ARP (IC806) → Decrypt (IC811) → AV Decoder (IC203)

- Error 04: Data read error
- 05: Write/read data mismatch error
- 06: DMA transfer DREQ error
- 07: DMA transfer address error
- 10: Chip-to-chip data transfer error

AC-3 audio data stored in ROM (IC803) are written to the ARP (IC806), then whether they are transferred to the AV Decoder (IC203) is checked. If transfer error is not detected, the address of AV Decoder (IC203) to which data are transferred is displayed on the terminal.

A part of data transferred to the AV Decoder (IC203) is read into Syscon RAM (IC802) through DMA, and compared with ROM (IC803) data.

#### (7-7) Interrupt Line in AV Decoder (IC203)

DRAM data of AV Decoder (IC203) → (DMA COPY) DRAM in AV Decoder (IC203) another area

Error 31: AV Decoder (IC203) interruption is not detected

Data transfer stop interruption which is generated through DMA copy of DRAM data in AV Decoder (IC203) to another area is detected.

#### (8) Video Consumption Concerned

##### (8-2) Video Encoder (Serial) (IC252)

Color bar output (color bar enable command) from Video Encoder (IC252)

Error 11: Serial transfer error

Using the Vsync interruption, serial communication to the Video Encoder (IC252) starts, and the color bar enable command is transferred to the Video Encoder (IC252).

The Vsync interruption and internal serial 1 interruption are used. If no error is found, the message is displayed to prompt for key entry.

Check the color bar output.

##### (8-3) Video Encoder (IC252) Read

ID read → Existing data matching check

Error 40: Video Encoder (IC252) ID error

The Video Encoder (IC252) device ID is read.

Error if the read value is not "1914 (hex)".

##### (8-4) Video Encoder (IC252) Vsync

CPU measures the Video Encoder (IC252) Vsync interrupt cycle.

Error 41: Vsync interruption is not detected

42: Vsync interrupt cycle error

The number of interruption for 200 msec is counted, and if it is 11 to 13 times, this check is OK. It should be 12 times exactly, but ±1 errors are allowable.

##### (8-5) Still Picture Output (SDRAM (IC201, 202) direct write)

Pattern data → AV Decoder (IC203) → Video Out

Error 31: AV Decoder (IC203) interruption (DMA transfer) is not detected

The pattern is directly written to the SDRAM (IC201, 202) of AV Decoder (IC203), then its picture display is checked.

First, the brightness signal data are written by the amount of one screen while changing every pixel.

For the color difference signals, both Cr and Cb are set to 80h for monochromatic pictures, and the display is turned on.

Then, color difference signal data are written while changing the data every column.

As both brightness signal data and color difference signal data take regular patterns, the processing speed is increased through DMA transfer of the repeated sections.

Further, in detail check the color difference signal data written to the out of display area are copied through DAM transfer to change display colors successively.

If no error is found, the message is displayed to prompt for key entry.

Check the pattern output.

##### (8-6) Still Picture Output (via ARP (IC806))

ROM picture data → ARP (IC806) → AV Decoder (IC203) → Video Out

Error 10: Chip-to-chip data transfer error

ROM (IC803) data are transferred to the AV Decoder (IC203) via ARP (IC806), and the displayed picture is checked.

If no error is found, the message is displayed to prompt for key entry.

The output picture is same as the start-up picture.

##### (8-7) DNR (Serial) (IC251)

ROM picture data → ARP (IC806) → AV Decoder (IC203) → DNR (IC251) → Video Out (outline)

Error 10: Chip-to-chip data transfer error

Using special diagnostic command, the output still picture is transferred to the DNR (IC251) for checking.

If no error is found, the message is displayed to prompt for key entry.

This checking is made only for the players with DNR (IC251).

The output picture used is same as that in (8-6) Still Picture Output.

The colors will vary extremely, if DNR (IC251) is effective.

For the players without DNR (IC251), the error code 0 is returned.

#### (8-8) S Terminal DC Check

Color bar output by NTSC Encoder in Video Encoder (IC252)

Error 11: Serial transfer error

The color bars are output in the same manner as in (8-2).  
After VS signal is turned on/off repeatedly two times, the color bar output is turned off.

#### (8-14) Component Output Check

Color bar output by NTSC Encoder in Video Encoder (IC252)

Error 11: Serial transfer error

With AV-CONT: "H", Component output "ON", video signals are output.  
The color bars are output from the player, same as in (8-2).

#### (9) Audio Concerned

##### (9-2) Sampling Frequency 44.1kHz

16.9344MHz oscillation

Error 37: PLL DAC (IC209) serial transfer interruption is not detected

Sampling frequency 44.1kHz is set to the PLL DAC (IC209).  
If no error is found, the message is displayed to prompt for key entry.  
Observe the output waveform of IC209 (CXD8696R) SCK02 pin.

##### (9-3) Sampling Frequency 48kHz

18.4320MHz oscillation

Error 37: PLL DAC (IC209) serial transfer interruption is not detected

Sampling frequency 48kHz is set to the PLL DAC (IC209).  
If no error is found, the message is displayed to prompt for key entry.  
Observe the output waveform of IC209 (CXD8696R) SCK02 pin.

##### (9-4) Sampling Frequency 96kHz

36.8640MHz oscillation

Error 37: PLL DAC (IC209) serial transfer interruption is not detected

Sampling frequency 96kHz is set to the PLL DAC (IC209).  
If no error is found, the message is displayed to prompt for key entry.  
Observe the output waveform of IC209 (CXD8696R) SCK02 pin.

#### (9-5) Audio Digital Output

ROM audio data → ARP (IC806) → AV Decoder (IC203) → Digital audio I/F output

Error 10: ARP (IC806) → AV Decoder (IC203) data transfer error  
37: PLL DAC (IC209) serial transfer interruption is not detected

AC-3-audio bit stream data stored in ROM (IC803) are transferred to the AV Decoder (IC203) via ARP (IC806), and output to the digital audio interface.

If no error is found, the message is displayed to prompt for key entry.  
Analog outputs are muted.

#### (9-6) Audio Digital Mute

ROM audio data → ARP (IC806) → AV Decoder (IC203) → Digital Audio I/F output

Error 10: ARP (IC806) → AV Decoder (IC203) data transfer error  
37: PLL DAC (IC209) serial transfer interruption is not detected

AC-3-audio bit stream data stored in ROM (IC803) are transferred to the AV Decoder (IC203) via ARP (IC806), and output to the Digital Audio Interface. In such a case, the mute signal is turned on/off alternately while the data are output 4 times.

1st time	: Mute off	Audible
2nd time	: Mute on	Not audible
3rd time	: Mute off	Audible
4th time	: Mute on	Not audible

If no error is found, the message is displayed to prompt for key entry.

#### (9-7) MPEG Audio Analog Output

ROM audio data → ARP (IC806) → AV Decoder (IC203) → 2ch DAC (IC215) → Analog audio output

Error 10: ARP (IC806) → AV Decoder (IC203) data transfer error  
35: 2ch DAC (IC215) serial transfer interruption is not detected  
37: PLL DAC (IC209) serial transfer interruption is not detected

MPEG-audio bit stream data stored in ROM (IC803) are transferred to the AV Decoder (IC203) via ARP (IC806), and analog audio data are output from 2ch DAC (IC215).

If no error is found, the message is displayed to prompt for key entry.

### (9-8) Dual DAC (Serial)

ROM audio data → ARP (IC806) → AV Decoder (IC203) → 2ch DAC (IC215) → Analog audio output (Attenuation)

Error 10: ARP (IC806) → AV Decoder (IC203) data transfer error  
35: 2ch DAC (IC215) serial transfer interruption is not detected  
37: PLL DAC (IC209) serial transfer interruption is not detected

MPEG-audio bit stream data stored in ROM (IC803) are transferred to the AV Decoder (IC203) via ARP (IC806), and they are attenuated by 12dB (-12dB) in the 2ch DAC (IC215), then analog audio data are output.

If no error is found, the message is displayed to prompt for key entry.

### (9-9) Audio Mute Line

ROM audio data → ARP (IC806) → AV Decoder (IC203) → Analog audio output (Mute)

Error 10: ARP (IC806) → AV Decoder (IC203) data transfer error  
35: 2ch DAC (IC215) serial transfer interruption is not detected  
37: PLL DAC (IC209) serial transfer interruption is not detected

MPEG-audio bit stream data stored in ROM (IC803) are transferred to the AV Decoder (IC203) via ARP (IC806), and analog audio data are output from 2ch DAC (IC215).

In such a case, first the mute by I/O of SH (IC805), then the mute by setting AV Decoder (IC203), and by setting DAC are turned on respectively to output low frequency tones.

Finally, the mute is turned off to output high frequency tones.

Checking is finished when high frequency tones are heard.

Low tones will be heard before this checking finished, if the mute is not effective.

To make sure which mute is not effective, the check should be repeated while paying attention to the message.

If no error is found, the message is displayed to prompt for key entry.

### ○ Error Codes in Diagnostic Test

01: Mode not supported is selected  
02: Reset error  
03: Data write error  
04: Data read error  
05: Write/read data mismatch error  
06: DMA transfer DREQ error  
07: DMA transfer address error

10: Chip-to-chip data transfer error  
11: Serial transfer error  
12: EEPROM (IC801) is not ready  
13: DSP (IC506) data is not ready  
14: DSP (IC506) download error

21: ARP (IC806) interruption is not detected  
22: Decrypt (IC811) interruption is not detected

31: AV Decoder (IC203) interruption is not detected  
32: Servo DSP interruption is not detected  
33: SSI interruption is not detected  
34: DNR (IC251) interruption is not detected  
35: 2ch DAC (IC215) interruption is not detected  
36: EEPROM (IC801) interruption is not detected  
37: PLL DAC (IC209) interruption is not detected

40: Video Encoder (IC252) ID error  
41: Vsync interruption is not detected  
42: Vsync interrupt cycle error

53: Video Encoder (IC252) interruption is not detected

90: Judged as error by inspector  
91: Check of this item is quitted by key entry  
92: Check of all items is quitted by key entry  
93: Interruption by time over  
99: Other errors



## 6-5. Drive Auto Adjustment

The drive can be automatically adjusted, except disc change and tangential skew adjustment. For a disc, use the disc for adjustment.

In case of abnormality, press the [STOP] key to stop adjustment. If the drive does not stop, prevent secondary failure by taking proper action such as disconnection of the power cable. This adjustment should be made after repair is finished and no trouble is present in the drive.

A trouble, if present, causes NG and the adjustment to be aborted. As the secondary failure could occur, perform automatic adjustment after the drive is completely repaired.

With the initial menu displayed, press [1] on standard commander, and the screen as shown in Figure 8 will appear.

```

Drive Auto Adjustment
SA.00000  SI.00  EMG.OO

Select No.                ←Blinking
0:  All          3:  CD
2:  DVD SL      4:  DVD-DL

STOP:  Press STOP Key
    
```

**Figure 8**

If "All" is selected, the screen shown in Figure 9 is displayed.

```

Drive Auto Adjustment
SA.00000  SI.00  EMG.OO

0:  Adjustment ALL
   0:  All          2:  CD
   2:  DVD SL      3:  DVD-DL

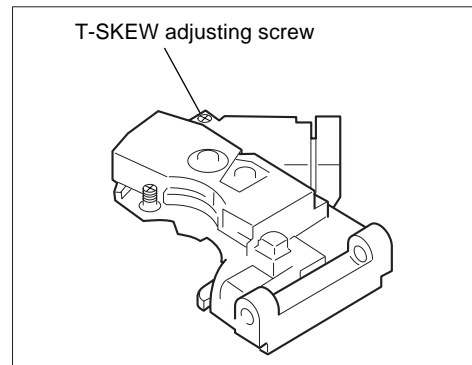
START:  Press ENTER Key  ←Blinking
STOP:   Press STOP Key
    
```

**Figure 9**

The tray opens after the [ENTER] key is pressed and the initialization is finished. Then, place the DVD\_SL disc for adjustment. Press the [ENTER] key to start adjustment. During adjustment, the tangential skew adjustment screen is displayed. Make this adjustment only when the pickup was replaced.

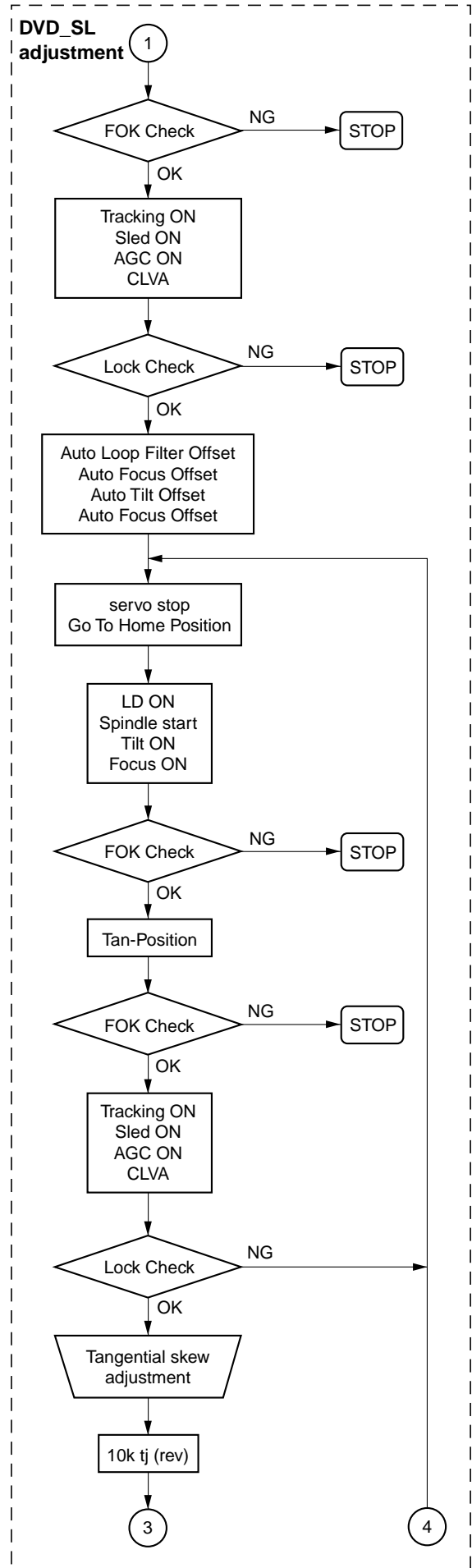
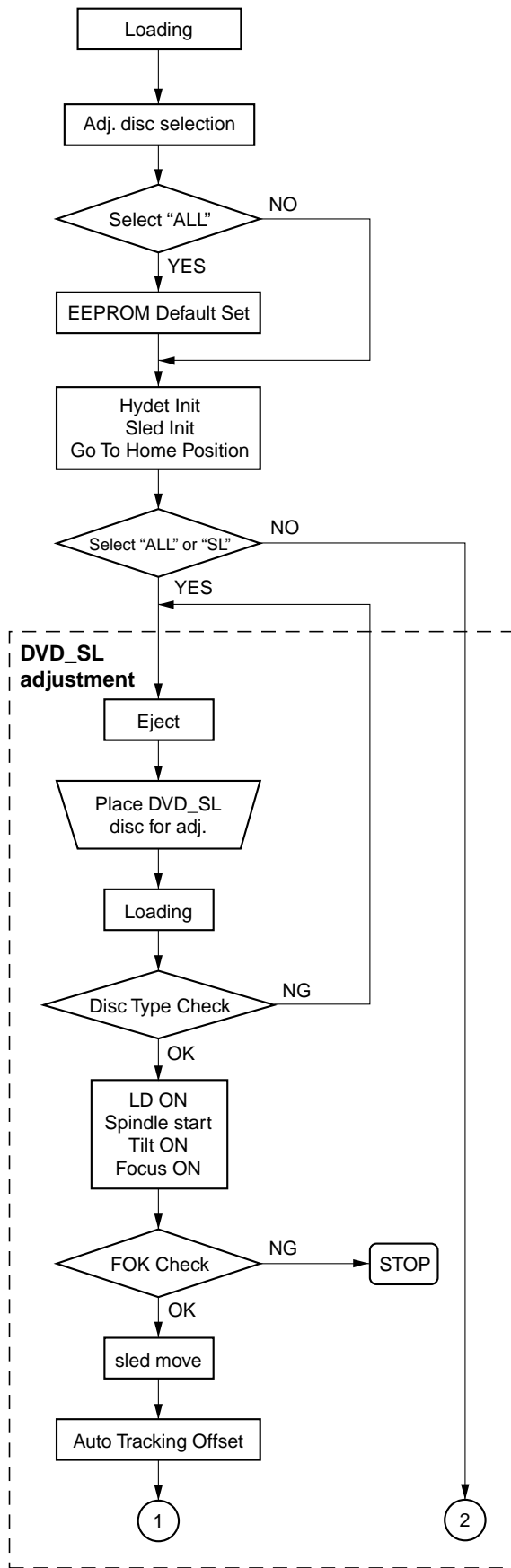
As for adjustment, rotate the T-SKEW adjusting screw on the pickup so that the displayed jitter becomes minimum (CCW makes jitter smaller). Avoid extreme rotation or interference of screwdriver with the disc. After adjustment, a message to apply a screw locking agent will be displayed if jitter value is within the specification. Then, apply a drip of locking agent to the recess of screw. Hence, change discs following the given messages on OSD, and the adjustment is finished if there is no problem.

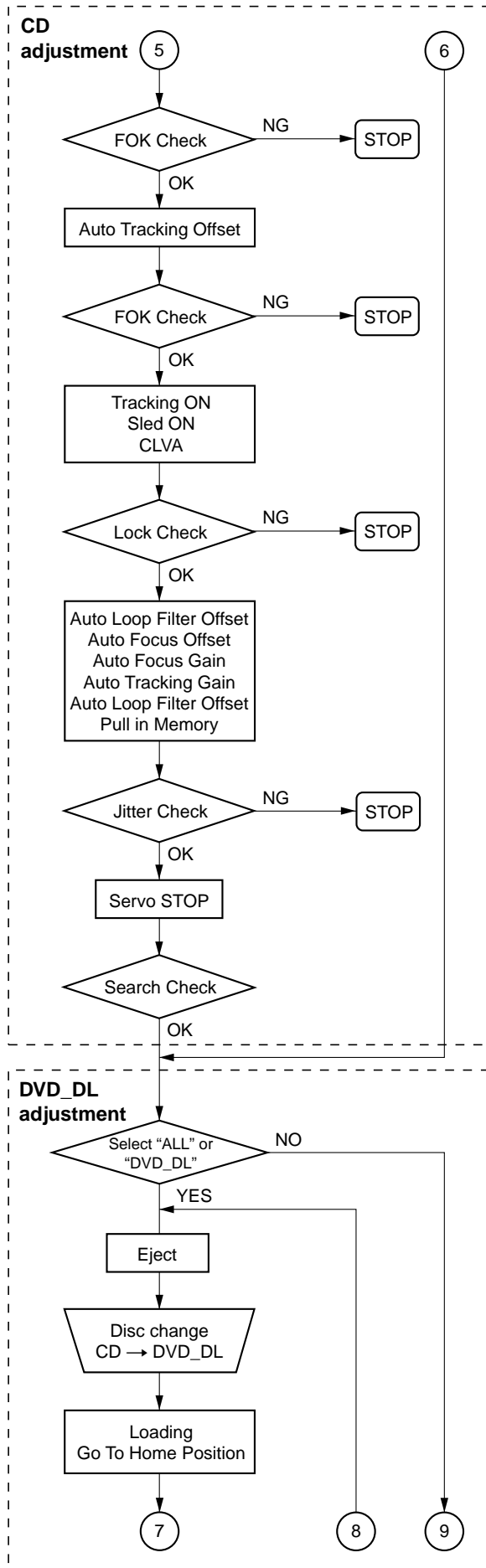
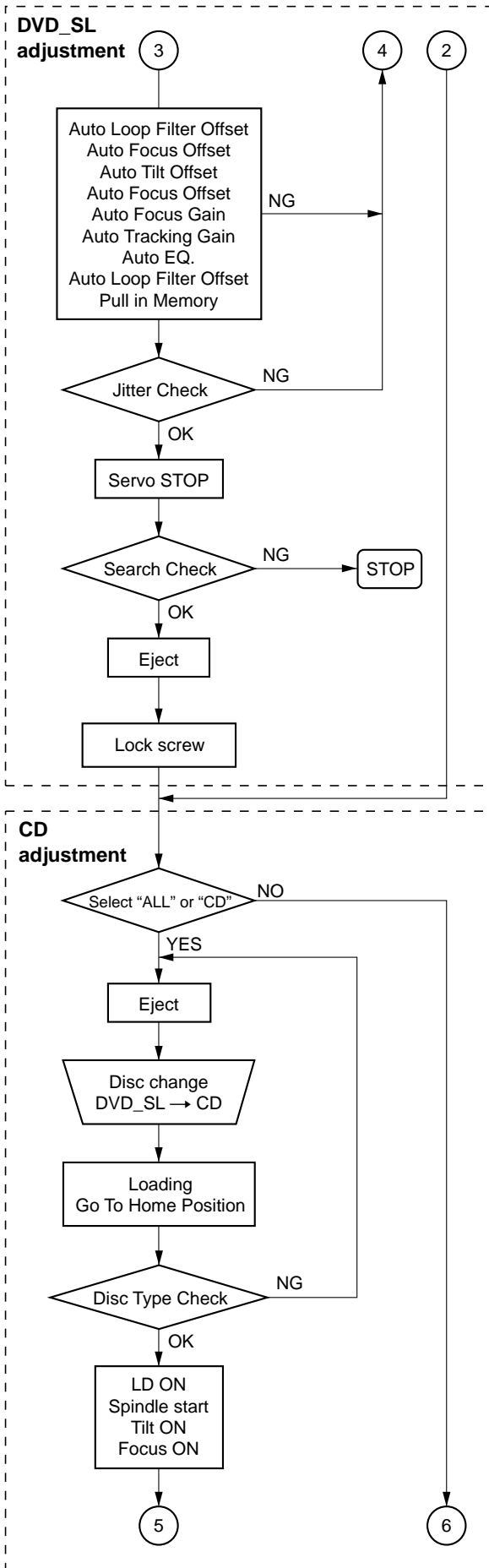
Note that if "All" is selected, the data of previous adjustment are erased and initial values are set.

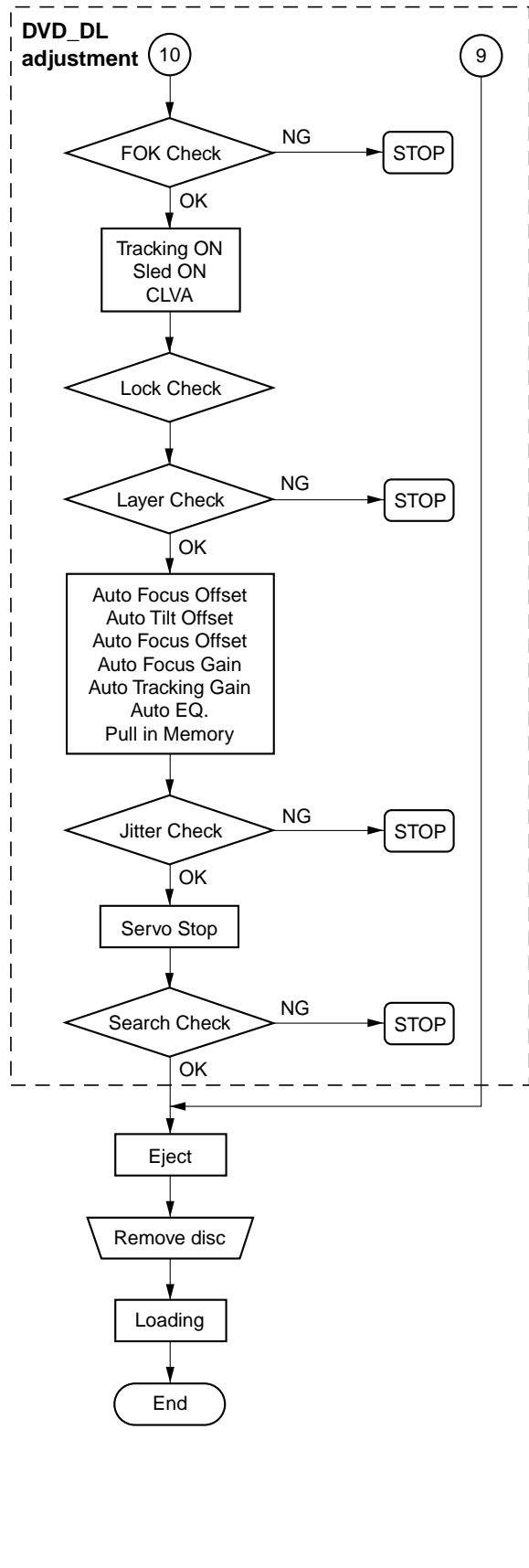
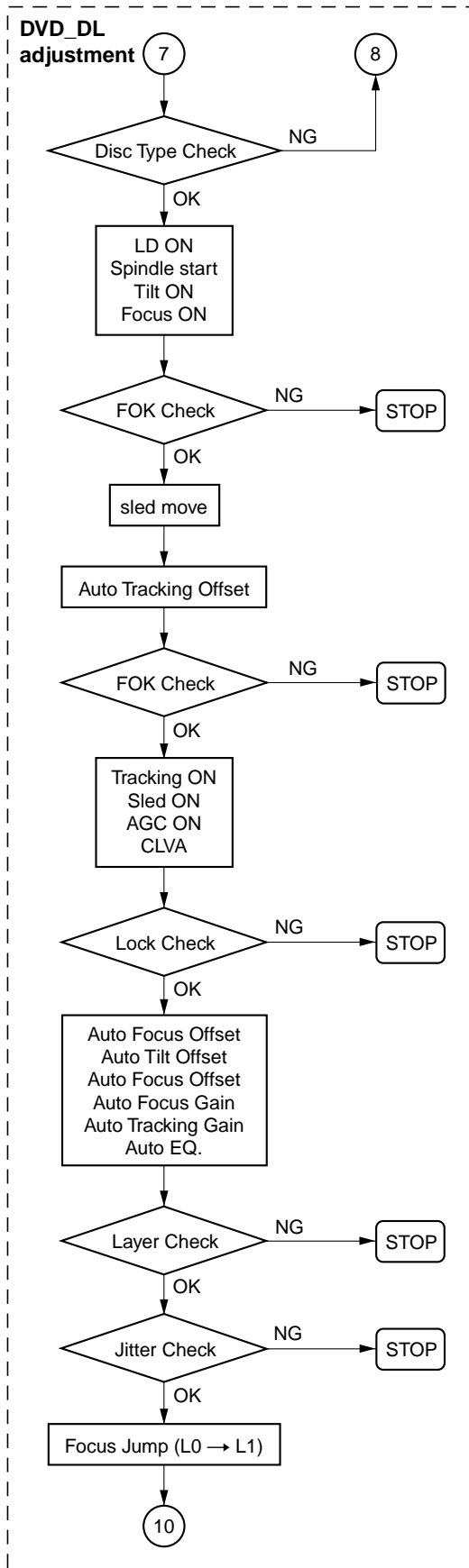


**Figure 10**

# Drive Automatic Adjustment Flowchart







## 6-6. Drive Manual Operation

In performing manual operation, observe the following points:  
Select correct disc type on the Disc Type screen.

First, select "0. Disc Type" and execute "7. Hydet init" and "8. Sled init". (See Figure 12)

In case of abnormality, press [STOP] immediately to stop operation and turn off the power.

Do not execute Auto Adjust while executing FG Pause.

Also, as these commands are not protected, take care not to press wrong key.

When PLL is locked, the sector address (or time code) is displayed on the right side of SA.

### 6-6-1. Drive Manual Operation Menu Screen

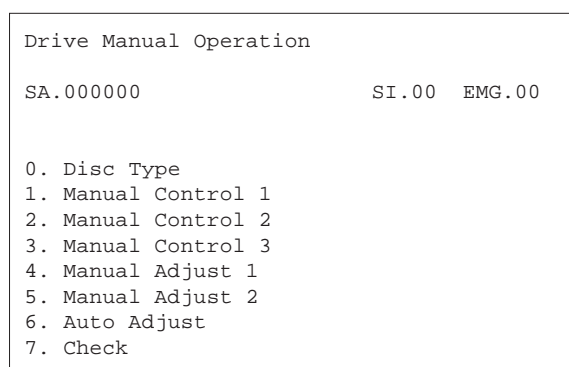


Figure 11

This screen provides a menu for manual operation, and you can go directly to each screen from here. To return to this screen from each screen, press the RETURN key.

If [SET UP] button is pressed, the screen returns to the Test Mode menu.

For switching between respective screens, use the [CLEAR] key.

### 6-6-2. Disc Type

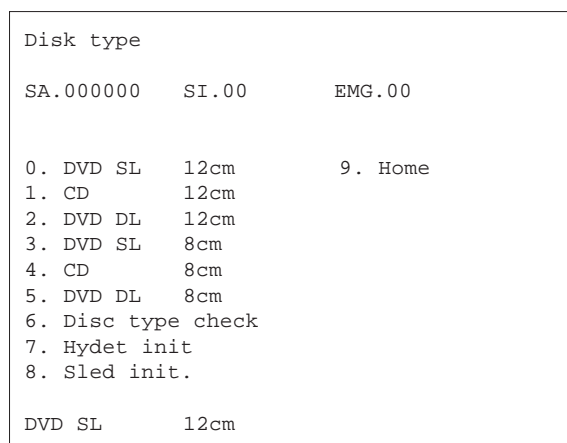


Figure 12

On this screen, select the type of disc used.

"6. Disc type check" judges the disc loaded. Confirm that judgment result meets the loaded disc type.

Judgment may fail if adjustment is not made yet immediately after EEPROM (IC801) Default Set. The CD which is not cut up to the CD detection sensor position is judged as DVD. The optical system will be damaged if other disc is loaded after selecting DVD DL.

Be sure to set the disc type.

### 6-6-3. Manual Control 1

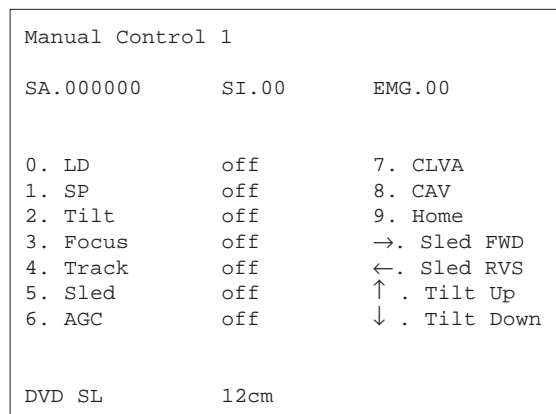


Figure 13

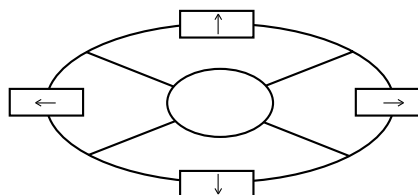
On this screen, turn on/off servo operation items necessary for playing.

Normally, turn on the items from 0 sequentially, and normal trace is executed at CLVA. In the tracking status, the sector address (or time code (at CD)) is displayed.

If not displayed, the spindle is not locked, which means a failure.

In case of spindle system failure or no RF, the spindle system may run, overriding the control.

In this case, do not press the CLVA.



0. LD : Turn on/off the laser diode.

1. SP : Turn on/off the spindle.

At SP ON, the spindle runs in constant velocity mode.

2. TILT : Turn on/off the tilt servo.

3. Focus : Focus searching is executed and focus is turned on.

Operation is terminated if focus is not turned on after focus search is retried about 3 times.

4. Track : Turn on/off the tracking servo.

5. Sled : Turn on/off the sled servo.

6. AGC : Turns on/off the focus error auto gain control by PULL IN level.

7. CLVA : Spindle normal servo.

8. CAV : Spindle in constant velocity mode

9. Home : Return to home position.

→. Sled FWD : Move the sled system outside.

Perform this with the tracking turned off.

←. Sled RVS : Move the sled system inside.

Perform this with the tracking turned off.

↑. Tilt Up : Move the tilt system up.

↓. Tilt Down : Move the tilt system down.

### 6-6-4. Manual Control 2

Manual Control 2		
SA.000000	SI.00	EMG.00
0. Pause	off	4. Eject
1. FCS.Srch	off	5. Load
3. Tilt_H	off	
DVD SL	12cm	

Figure 14

Eject/Load are not used usually, because they can be done with the [EJECT] button.

- 0. Pause : Pause is made by executing track jump once per revolution.
- 1. FCS.Srch : The focus drive system is checked by applying same voltage to the focus drive as that in focus search.
- 3. Tilt H : Increase tilt gain.
- 4. Eject : Eject
- 5. Load : Loading

### 6-6-5. Manual Control 3

Manual Control 3		
SA.000000	SI.00	EMG.00
0. FWD	32TJ	6. FT0→1
1. RVS	32TJ	7. FJ1→0
2. FWD	500TJ	8. LJ0→1
3. RVS	500TJ	9. LJ1→0
4. FWD	10KTJ	→. FWD 1TJ
5. RVS	10KTJ	←. RVS 1TJ
DVD SL	12cm	

Figure 15

On this screen, track jump, etc. are executed.

Confirm the sector information (SI) to check the DVD\_DL layer jump direction. Even SI means layer 0, or odd SI means layer 1. When 1TJ or 32TJ is executed, the tracking is turned on, but the sled becomes just like initialization.

Also, after executing each jump except 1TJ (and FJ1, 2), the CLVA mode is set.

The optical system will be damaged if make a jump in wrong direction FJ0, FJ1, LJ0 and LJ1.

- 0. FWD 32TJ : Jump 32 track forward (N track jump).
- 1. RVS 32TJ : Jump 32 track reversely (N track jump).
- 2. FWD 500TJ : Jump 500 tracks forward (fine search).
- 3. RVS 500TJ : Jump 500 tracks reversely (fine search).
- 4. FWD 10KTJ : Jump 10k tracks forward (direct search).
- 5. RVS 10KTJ : Jump 10k tracks reversely (direct search).
- 6. FJ0→1 : After layer jump L0→L1, tracking loop does not turn on.
- 7. FJ1→0 : After layer jump L1→L0, tracking loop does not turn on.
- 8. LJ0→1 : After layer jump L0→L1, tracking loop turns on.
- 9. LJ1→0 : After layer jump L1→L0, tracking loop turns on.

- . FWD 1TJ : Jump one track forward.
- ←. RVS 1TJ : Jump one track reversely.

### 6-6-6. Manual Adjust 1

Manual Adjust 1		
SA.000000	SI.CD	EMG.00
0. TRK. Off set		xx
1. TRK. Off set 2 (DVD)		
2. TRK. Gain 2 (CD)		
3. Focus Gain		
4. TRK. Gain		
CD	12cm	

Figure 16

On this screen, manual adjustment can be made where jitter measurement is not executed.

- 0. TRK. Offset<sup>1</sup> : Adjust tracking offset.
- 1. TRK. Offset 2 (DVD) : Adjust DVD tracking offset (TO SSI). Adjusting range is (A1 – AF) with A1 – A7: +25 to +175 mV, A8 – AF: 0 to –175mV.
- 2. TRK. Gain 2 (CD) : Adjust simple AGC of CD. Adjusting range is (88 – C8) with lower 4 bits fixed.
- 3. Focus Gain : Adjust focus gain.
- 4. TRK. Gain<sup>2</sup> : Adjust tracking gain.

<sup>1</sup>TRK. Offset : In the tracking offset adjustment for DVD, based on the peak and bottom data measured by DSP (IC506), the SSL33P3720A cancels the offset roughly, then the DSP (IC506) adjusts it finely. Here, finely adjusted value is set. As adjustment is made by DSP (IC506) only. DC component of tracking traverse does not change. For the CD, only this set value changes.

<sup>2</sup>TRK. Gain : In the tracking gain adjustment for CD, based on the peak and bottom data measured by DSP (IC506), the CXA2556 on the sets simple AGC to 5 steps of –3.2, –1.6, 0, +1.6, +3.2 dB (Auto Tracking Offset), then the DSP (IC506) makes setting (Auto Tracking Gain). Here, DSP (IC506) setting can be made. In the case of DVD, only DSP (IC506) setting is executed.

### 6-6-7. Manual Adjust 2

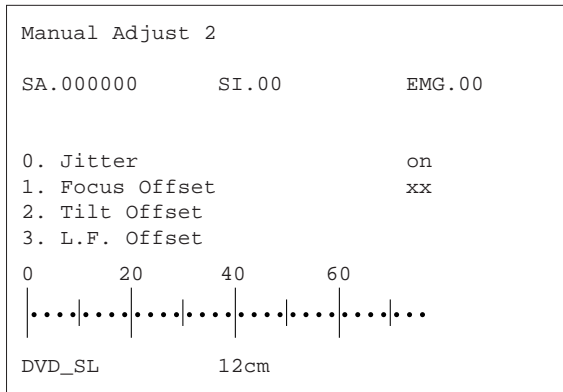


Figure 17

On this screen, manual adjustment can be made where jitter measurement is executed.

- 0. Jitter : Turn on/off jitter measurement. Jitter will not be measured unless the drive runs at CLV.
- 1. Focus Offset : Adjust focus offset.
- 2. Tilt Offset : Adjust tilt offset.
- 3. L.F. Offset : Adjust electrical offset in ARP (IC806).

### 6-6-8. Auto Adjust

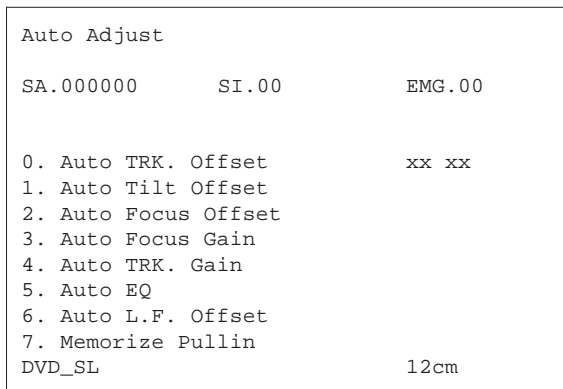


Figure 18

On this screen, each item can be automatically adjusted individually.

Note, however, that there are some restriction.

- 0. Auto TRK Offset : Adjust tracking offset automatically. Adjusted result is reflected on the EEPROM (IC801). Turn off tracking with the Focus turned on. Do not execute this at outside track because pickup moves outside. In the case of CD, tracking simple AGC is also adjusted here.
- 1. Auto Tilt Offset : Adjust tilt offset automatically. Adjusted result is reflected on the EEPROM (IC801). Execute this with CLVA turned on. If NG, retry this after focus offset and tangential skew are adjusted.
- 2. Auto Focus Offset: Adjust focus offset automatically. Adjusted result is reflected on the EEPROM (IC801). Execute this with CLVA turned on. If NG, retry this after tilt offset and tangential skew are adjusted.

- 3. Auto Focus Gain : Adjust focus gain automatically. Adjusted result is reflected on the EEPROM (IC801). Execute this with CLVA turned on if possible. If NG, the system will be defective, and repair it.
- 4. Auto TRK gain : Adjust tracking gain automatically. Adjusted result is reflected on the EEPROM (IC801). Execute this with CLVA turned on if possible. If NG, the system will be defective, and repair it.
- 5. Auto EQ : Adjust RF equalizer properly. Adjusted result is not reflected on the EEPROM (IC801). Execute this with CLVA turned on.
- 6. Auto L.F. Offset : Adjusts electrical offset in ARP (IC806). The adjusted value is applied to the EEPROM (IC801). During adjustment, lock the CLV.
- 7. Memorize Pullin : Sets the pull-in level to the EEPROM (IC801).

### 6-6-9. Check

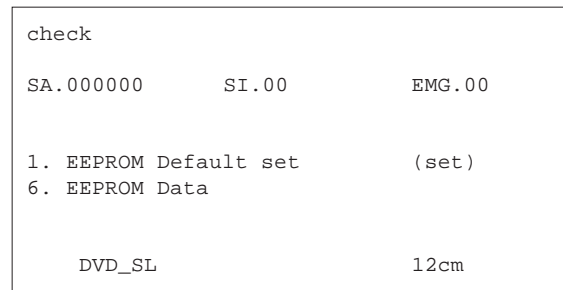


Figure 19

On this screen, various checking can be made. Note, however, that some items such as EEPROM (IC801) Default set are not recoverable.

- 1. EEPROM Default set : Use this to set EEPROM (IC801) set values to default values. Before executing this, it is recommended to record current values.
- 6. EEPROM data : Display EEPROM (IC801) set values list. Display is made with HEX numbers "00" – "FF".

### 6-6-10. EEPROM Data Screen Display

EEPROM data					
ID	No.	00	CD	DVD	
			SL	L0	L1
Focus Offset		80	80	80	80
Focus Gain		30	18	30	30
TRK Offset		80	80	80	80
TRK. CONT.		??	??	??	??
TRK Gain		30	30	30	30
Tilt Offset		80	80	80	80
Pullin Level		9e	9f	ab	ab
EQ. Boost		??	??	??	??
L.F.O		??	??	??	??
SD. ?? HY. ??					

**Figure 20**

This screen displays various set values including adjusted results stored in the EEPROM (IC801).

- ID No. : Nothing is displayed (00 is displayed)
- Focus Offset : 00 – FF 80 center (DVD\_SL)
- Focus Gain : 00 – 7F 20 center (DVD\_SL)
- TRK. Offset : 00 – FF 80 center (DVD\_SL)
- TRK. CONT. : Refer to Manual adjust 1 Tracking offset 2 and Tracking gain.
- TRK. Gain : 00 – 7F 20 center (DVD\_SL)
- Tilt Offset : 00 – FF 80 center (DVD\_SL)
- Pullin Level : 80 – FF D0 center (DVD\_SL)
- EQ. Boost : Fixed according to the disc type.
- L.F.O : Only lower 5 bits are effective.
- SD. : About 50 – E0
- HY. : About 60 – A0

### 6-7. Other Operation

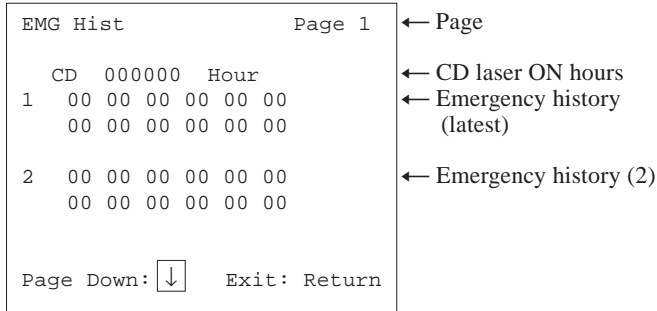
For manual operation of the drive, the following operations are available, besides the operations given on the menu screen. (Common to front panel and remote commander)

Eject/Loading	OPEN/CLOSE button	Stop+Ejection, and Loading
Clear	CLEAR button	Movement throughout the menu
Stop	STOP button	Servo stop
Retrun	RETURN button	Return to drive manual operation
Set up	SET UP button	STOP, then return to test mode menu
Cursol key	→↑ keys	Increase manually adjusted value
Cursol key	←↓ keys	Decrease manually adjusted value
Power	POWER button	Power OFF

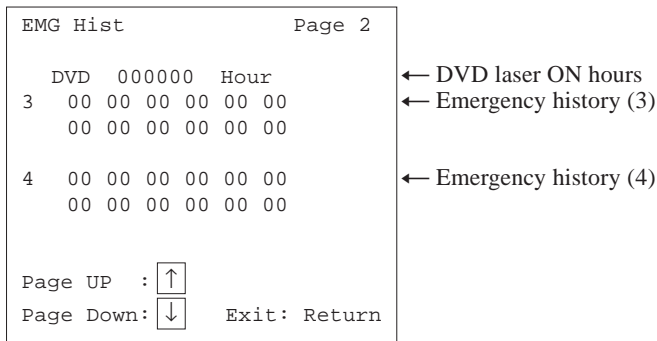


## 6-8. Emergency History

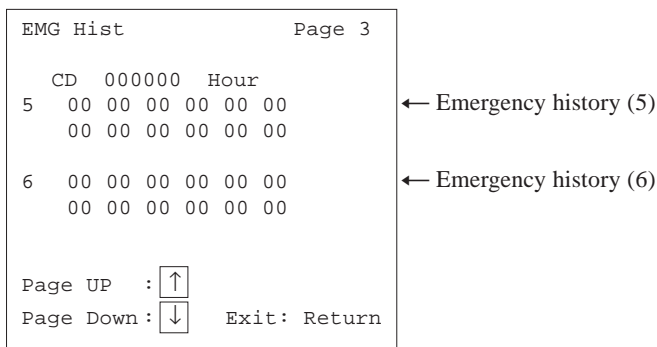
With the initial menu displayed, press [4] key on the remote commander (RMT-D107A), and the information on emergency history of Drvcon and Syscon will be displayed. This information is given over four pages, which can be changed over with [↑] and [↓] keys. To return to the initial menu, press [RETURN] key.



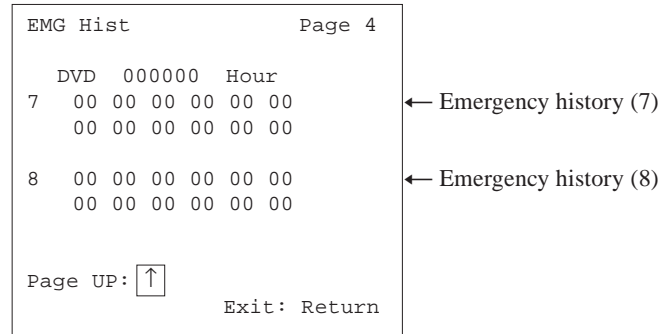
**Figure 21**



**Figure 22**



**Figure 23**



**Figure 24**

The following hidden commands are available. Data clear can be confirmed from the fact that the screen display changes.

⊙ Clearing laser ON hours

Press [DISPLAY] and [CLEAR] keys on the remote commander (RMT-D107A) in this order.

⊙ Clearing emergency history

Press [TITLE] and [CLEAR] keys on the remote commander (RMT-D107A) in this order.

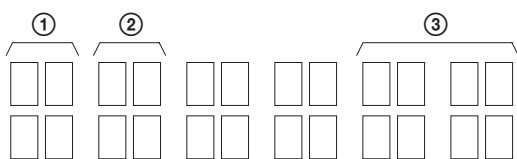
After repair is finished, always clear emergency history data.

⊙ Clearing Syscon preset

Press [DVD MENU] and [CLEAR] keys on the remote commander (RMT-D107A) in this order.

For EMG code, Mech mode, and Disc information of history display, see “Emergency code list”, “Mech mode list”, and “Disc type list”.

## How to see Emergency History



### ① EMG CODE

### ② MECHA MODE

### ③ DISC TYPE (Mecha Mode: 6□)

#### ① EMG CODE (Emergency code list)

##### Digital Pass

- 01: EEPROM (IC801) Write NG
- 02: EEPROM (IC801) Read NG
- 03: EEPROM (IC801) Busy Time Out
- 04: Emergency History Pointer NG
- 06: IFCON SYSCON Communication NG
- 07: IFCON V-sync NG

##### Electrical Adjustment

- 10: EEPROM (IC801) Check NG
- 16: DSP (IC506) Check NG

##### Mecha

- 20: Home Position Time Out
- 21: Sled Driver NG
- 26: Tray NG
- 27: Roulette NG (Not used)

##### Tilt/Adaptation

- 30: Hy Det Level NG
- 31: Sled Offset Cancel NG
- 32: Focus Gain NG
- 33: Tracking Offset NG
- 34: Tracking Gain NG
- 35: Jitter NG

##### Focus

- 40: Focus Servo Lock NG
- 41: Focus Jump NG

##### Spindle

- 60: Miss Chuck
- 61: Spindle Lock Time Out
- 62: Spindle Reckless
- 63: CLV Lock NG
- 64: CLV Lock Time Out
- 65: CAV Speed NG
- 66: Spindle Speed × 1 NG

##### Seek System

- 70: Req Address NG
- 71: Req Time Code NG
- 72: Req Track No. NG
- 73: Seek NG

##### Data Relation

- 80: Address Continuity NG
- 81: Address Read NG
- 82: TOC Read Time Out
- 83 – 87: Physical Information Read Error
- 88: Layer No. NG
- 89: CD Text Data Read Error

##### Etc

- 90: Recovery NG
- 96: Auto Sequence Time Out
- 97: Auto Sequence Fail

##### Syscon

- A0: Stop request from drive controller was received
- A1: At the mode change command, the mode could not be changed within specified time and the drive stopped.
- A2: Retry due to supply error failed and the drive stopped.
- A3: Disc directory configuration and information file are illegal and the drive stopped.
- A4: The drive stopped as a DVD-R disc was used.
- A5: Coded data could not be decoded and the drive stopped.
- A6: At slow R, the destination of reverse search is illegal and the drive stopped.
- A7: Supply error and stopped.
- B0: SYSCON error was due to supply system.
- B1: SYSCON error was due to VIDEO hung up
- B2: DMX error
- B3: At slow R, data supply time out
- B4: At slow R, wrong Navi Pack sector address
- B5: At slow R, VIDEO hung up
- B6: At slow R, Gttgt end time out
- B7: At FF/FR, data supply time out
- B8: At FF/FR, VIDEO hung up

##### IFcon

- C0: IFCON ROM destination is wrong
- C1: IFCON UART1 communication port NG

##### Power system

- D0: The power turned off because of power off request from drive controller.
- D1: The mode change to Stop mode failed and the power turned off.

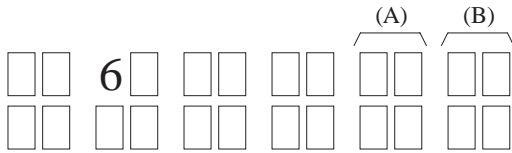
##### Drvcon

- E0: DRVCON system error
- E1: DRVCON system error

#### ② MECHA MODE (Mecha mode list)

- 00: Power ON Ready
- 10: Stop
- 20: Trace (data supply mode)
- 30: Pause
- 40: Drvcon Initialize
- 50: Mecha Initialize
- 6□: Spin Up
- 61: Adaptation (Tracking Offset)
- 62: Adaptation (Jitter/Gain)
- 63: TOC/Control Data Read
- 60: Etc
- 70: Spin Down
- 80: Seek
- 90: Error Recovery

③ Disc Type (Mecha Mode: 6□)



- (A) Last result of disc type judgment.  
 (B) Initial result of disc type judgment.

Disc type list

- FF: Unknown
- 00: No Disc
- 01: CD 12 cm
- 11: CD 8 cm
- 02: Single DVD 12 cm
- 12: Single DVD 8 cm
- 03: Dual DVD 12 cm
- 13: Dual DVD 8 cm
- 04: CDR 12 cm
- 14: CDR 8 cm
- 05: DVDR 12 cm
- 15: DVDR 8 cm

## 6-9. Error Code

The self-diagnosis function works to prevent the player from malfunctioning, a five-digit service number (combination of a letter and figures) flashes on the screen and front panel display.

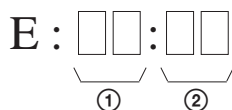
1. Each user needs to manage the error. .... "C" code

- C : 13 : □□
- The disc is dirty.  
→ Clean the disc with a cleaning cloth.
- C : 31 : □□
- The disc is not inserted correctly.  
→ Open the disc tray and insert the disc correctly.

MECHA MODE is shown in □□ position.

Code	Description
00	Power ON Ready
10	Stop
20	Trace (data supply mode)
30	Pause
40	Drvcon Initialize
50	Mecha Initialize
6□	Spin Up
61	Adaptation (Tracking Offset)
62	Adaptation (Jitter/Gain)
63	TOC/Control Data Read
60	Etc
70	Spin Down
80	Seek
90	Error Recovery

2. Each user needs to contact with the service section ..... “E” code



- ① EMG CODE
- ② DISC TYPE

① EMG CODE

Code	Description
01	EEPROM (IC801) Write NG
02	EEPROM (IC801) Read NG
03	EEPROM (IC801) Busy Time Out
04	Emergency History Pointer NG
06	IFCON SYSCON Communication NG
07	IFCON V-sync NG
10	EEPROM (IC801) Check NG
16	DSP (IC506) Check NG
20	Home Position Time Out
21	Sled Driver NG
26	Tray NG
27	Roulette NG (Not used)
30	Hy Det Level NG
31	Sled Offset Cancel NG
32	Focus Gain NG
33	Tracking Offset NG
34	Tracking Gain NG
35	Jitter NG
40	Focus Servo Lock NG
41	Focus Jump NG
60	Miss Chuck
61	Spindle Lock Time Out
62	Spindle Reckless
63	CLV Lock NG
64	CLV Lock Time Out
65	CAV Speed NG
66	Spindle Speed × 1 NG
70	Req Address NG
71	Req Time Code NG
72	Req Track No. NG
73	Seek NG
80	Address Continuity NG
81	Address Read NG
82	TOC Read Time Out
83 – 87	Physical Information Read Error
88	Layer No. NG
89	CD Text Data Read Error
90	Recovery NG
96	Auto Sequence Time Out
97	Auto Sequence Fail
A0	Stop request from drive controller was received

Code	Description
A1	At the mode change command, the mode could not be changed within specified time and the drive stopped.
A2	Retry due to supply error failed and the drive stopped.
A3	Disc directory configuration and information file are illegal and the drive stopped.
A4	The drive stopped as a DVD-R disc was used.
A5	Coded data could not be decoded and the drive stopped.
A6	At slow R, the destination of reverse search is illegal and the drive stopped.
A7	Information file reading failed and the drive stopped.
B0	SYSCON error was due to supply system.
B1	SYSCON error was due to VIDEO hung up
B2	DMX error
B3	At slow R, data supply time out
B4	At slow R, wrong Navi Pack sector address
B5	At slow R, VIDEO hung up
B6	At slow R, Gttgt end time out
B7	At FF/FR, data supply time out
B8	At FF/FR, VIDEO hung up
C0	IFCON ROM destination is wrong
C1	IFCON UART1 communication port NG
D0	The power turned off because of power off request from drive controller.
D1	The mode change to Stop mode failed and the power turned off.
E0	DRVCON system error
E1	DRVCON system error

② DISC TYPE

Code	Description
FF	Unknown
00	No Disc
01	CD 12 cm
11	CD 8 cm
02	Single DVD 12 cm
12	Single DVD 8 cm
03	Dual DVD 12 cm
13	Dual DVD 8 cm
04	CDR 12 cm
14	CDR 8 cm
05	DVDR 12 cm
15	DVDR 8 cm

## SECTION 7 ELECTRICAL ADJUSTMENT

In making adjustment, refer to 7-4. Adjustment Related Parts Arrangement.

**Note:** During diagnostic check, the characters and color bars can be seen only with the NTSC monitor. Therefore, for diagnostic check, use the monitor that supports both NTSC and PAL modes

This section describes procedures and instructions necessary for adjusting electrical circuits in this set.

### Instruments required:

- 1) Color monitor TV
- 2) Oscilloscope 1 or 2 phenomena, band width over 100 MHz, with delay mode
- 3) Frequency counter (over 8 digits)
- 4) Digital voltmeter
- 5) Remote commander (RTM-D107A)
- 6) DVD reference disc  
HLX-501 (J-6090-071-A) (dual layer)  
HLX-503 (J-6090-069-A) (single layer)
- 7) Extension cable (J-6090-079-A)  
MB-84 (CN601) ↔ FL-107 (CN153)

## 7-1. Power Supply Check

### 1. HS-930SU Board

Mode	E-E
Instrument	Digital voltmeter
+5.2 V Check	
Test point	CN201 ① pin
Specification	$5.2 \pm 0.2$ Vdc
+3.3 V Check	
Test point	CN201 ④ pin
Specification	$3.3 \pm 0.2$ Vdc
EVER+5 V Check	
Test point	CN201 ⑥ pin
Specification	$5.4 \pm 0.2$ Vdc
P_CONT Check	
Test point	CN201 ⑧ pin
Specification	4V – 5 Vdc
AU +12 V Check	
Test point	CN201 ⑨ pin
Specification	$12 \begin{smallmatrix} +1.0 \\ -2.0 \end{smallmatrix}$ Vdc
AU –12 V Check	
Test point	CN201 ⑪ pin
Specification	$-12 \begin{smallmatrix} +2.0 \\ -1.0 \end{smallmatrix}$ Vdc
–12 V Check	
Test point	CN201 ⑫ pin
Specification	$-12 \begin{smallmatrix} +2.0 \\ -1.0 \end{smallmatrix}$ Vdc
MTR +12 V Check	
Test point	CN201 ⑭ pin
Specification	$12 \begin{smallmatrix} +1.0 \\ -2.0 \end{smallmatrix}$ Vdc

### Checking method:

- 1) Confirm that each voltage satisfies the specification.

## 7-2. Adjustment of System Control

### 1. System Clock 27 MHz Adjustment (MB-84 board)

#### <Purpose>

27 MHz is the reference clock for the MPEG system, and if it is not adjusted correctly, checking of 22 MHz and 33 MHz lock in the following steps will result in NG.

Mode	E-E
Test point	IC206 ⑧ pin
Instrument	Oscilloscope, Frequency counter
Adjusting element	CT201
Specification	27000000 ± 100 Hz

#### Adjusting method:

- 1) Confirm that the waveform at TP018 is normal.
- 2) Adjust CT201 to attain 27000000 ± 100 Hz.



Figure 7-1

## 7-3. Adjustment of Video System

### 1. Video Level Adjustment (MB-84 board)

#### <Purpose>

This adjustment is made to satisfy the NTSC standard, and if not adjusted correctly, the brightness will be too large or small.

Mode	Video Encoder (IC252) check in test mode menu "0" Syscon Diagnosis
Signal	Color bars
Test point	LINE OUT (VIDEO) connector (75 Ω terminated)
Instrument	Oscilloscope
Adjusting element	RV251
Specification	1 ± 0.02 Vp-p

#### Adjusting method:

- 1) In the test mode initial menu "0" Syscon Diagnosis, set so that Video Encoder (IC252) color bars are generated.
- 2) Adjust the RV251 to attain 1 ± 0.02 Vp-p.



Figure 7-2

### 2. S-terminal Output Check (MB-84 board)

#### <Purpose>

Check S-terminal video output. If it is incorrect, pictures will not be displayed correctly in spite of connection to the TV with a S-terminal cable.

Mode	Video Encoder (IC252) check in test mode menu "0" Syscon Diagnosis
Signal	Color bars
Test point	S VIDEO OUT (S-Y) connector (75 Ω terminated)
Instrument	Oscilloscope
Specification	1 ± 0.05 Vp-p

#### Checking method:

- 1) In the test mode initial menu "0" Syscon Diagnosis, set so that Video Encoder (IC252) color bars are generated.
- 2) Confirm that the S-Y level is 1 ± 0.05 Vp-p.

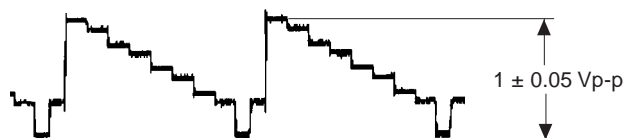


Figure 7-3

### 3. Checking Component Video Output B-Y (MB-84 board)

#### <Purpose>

This checks component video output B-Y. If it is incorrect, correct colors will not be displayed when connected to, for instance, projector.

Mode	Video Encoder (IC252) check in test mode menu "0" Syscon Diagnosis
Signal	Color bars
Test point	COMPONENT VIDEO OUT (B-Y) connector (75 Ω terminated)
Instrument	Oscilloscope
Specification	700 ± 30 mVp-p

#### Checking method:

- 1) Confirm that the B-Y level is 700 ± 30 mVp-p.

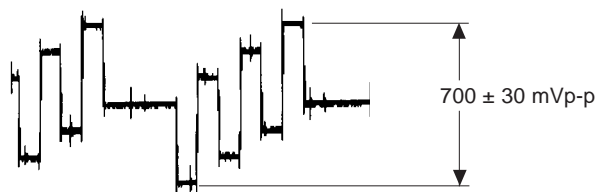


Figure 7-4

#### 4. Checking Component Video Output R-Y (MB-84 board)

##### <Purpose>

This checks component video output R-Y. If it is incorrect, correct colors will not be displayed when connected to, for instance, projector.

Mode	Video Encoder (IC252) check in test mode menu "0" Syscon Diagnosis
Signal	Color bars
Test point	COMPONENT VIDEO OUT (R-Y) connector (75 Ω terminated)
Instrument	Oscilloscope
Specification	700 ± 30 mVp-p

##### Checking method:

- 1) Confirm that the R-Y level is 700 ± 30 mVp-p.

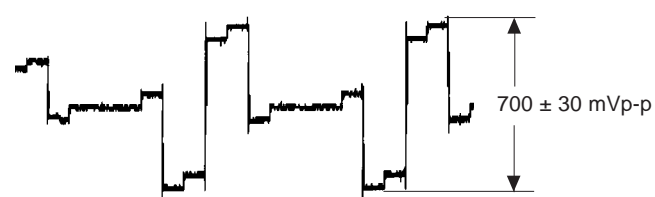


Figure 7-5

#### 5. Checking Component Video Output Y (MB-84 board)

##### <Purpose>

This checks component video output Y. If it is incorrect, correct brightness will not be attained when connected to, for instance, projector.

Mode	Video Encoder (IC252) check in test mode menu "0" Syscon Diagnosis
Signal	Color bars
Test point	COMPONENT VIDEO OUT (Y) connector (75 Ω terminated)
Instrument	Oscilloscope
Specification	1 ± 0.05 Vp-p

##### Checking method:

- 1) Confirm that the Y level is 1 ± 0.05 Vp-p.

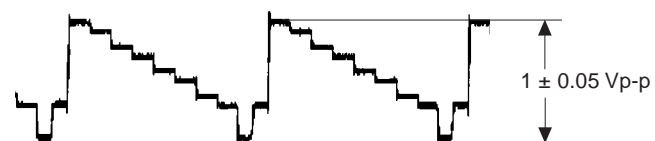


Figure 7-6

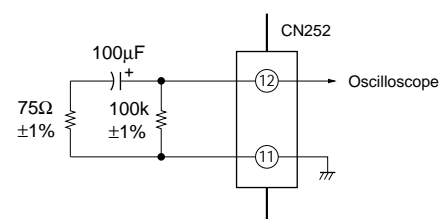
#### 6. Checking S Video Output S-C (MB-84 board)

##### <Purpose>

This checks whether the S-C satisfies the NTSC Standard. If it is not correct, the colors will be too dark or light.

Mode	Video Encoder (IC252) check in test mode menu "0" Syscon Diagnosis
Signal	Color bars
Test point	CN252 ⑫ pin
Instrument	Oscilloscope
Specification	286 ± 20 mVp-p

##### Connection:



##### Checking method:

- 1) Confirm that the S-C burst is 286 ± 20 mVp-p.



Figure 7-7

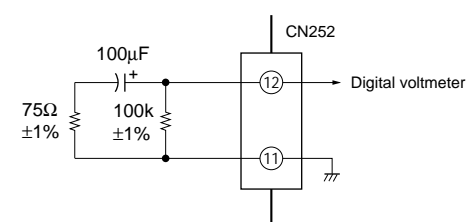
#### 7. Checking S Video Output DC Level (MB-84 board)

##### <Purpose>

This checks signals for S1 and S2 compatible TV. If they are not correct, the TV will not switch automatically to letter box, etc.

Mode	Video Encoder (IC252) check in test mode menu "0" Syscon Diagnosis
Signal	Color bars
Test point	CN252 ⑫ pin
Instrument	Digital voltmeter
Specification	S-terminal 0 V: 0 Vdc S-terminal 5 V: 5.0 <sup>+0</sup> <sub>-1.5</sub> Vdc

##### Connection:

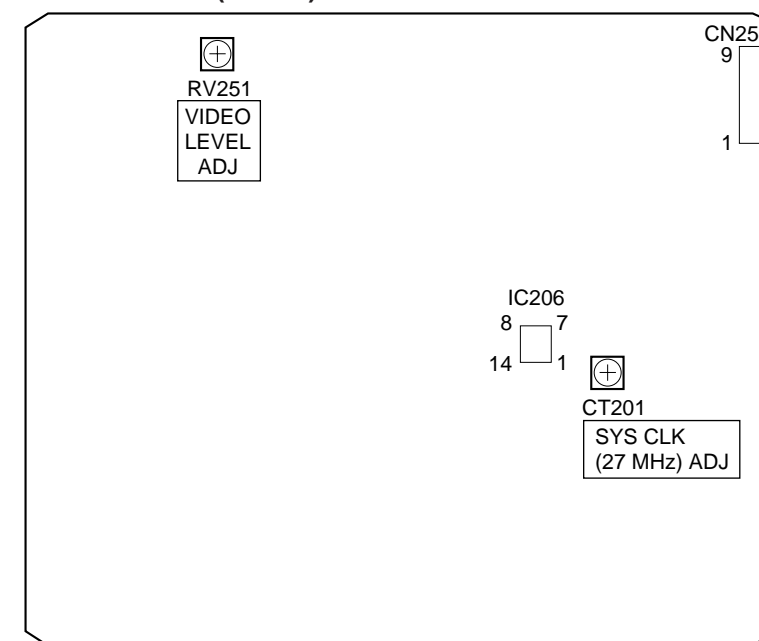


##### Checking method:

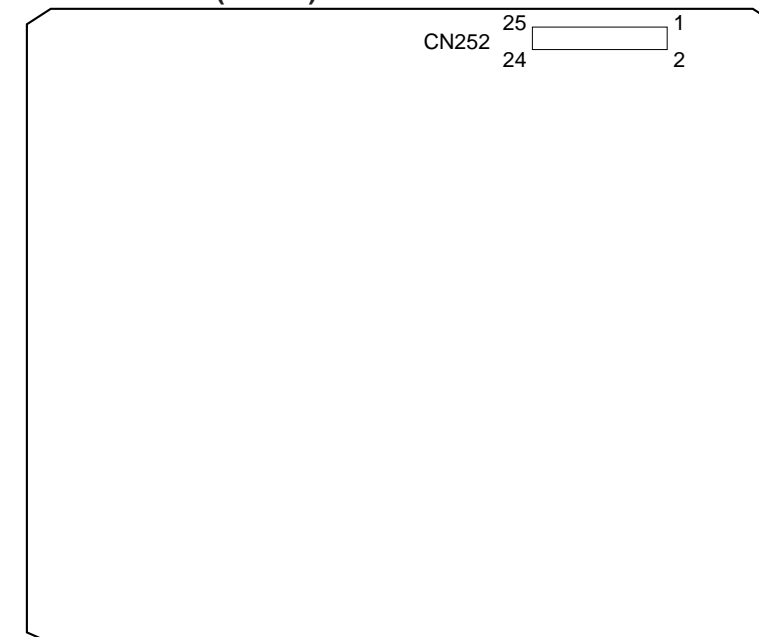
- 1) In the test mode initial menu "0" Syscon Diagnosis, select S-terminal 0 V.  
Confirm that the voltage at CN252 ⑫ pin is 0 Vdc.
- 2) Press any key to select S-terminal 5 V.  
Confirm that the voltage at CN252 ⑫ pin is 5.0<sup>+0</sup><sub>-1.5</sub> Vdc.

#### 7-4. Adjustment Related Parts Arrangement

##### MB-84 BOARD (Side A)



##### MB-84 BOARD (Side B)



##### HS-930SU BOARD (Side A)



## SECTION 8 REPAIR PARTS LIST

### 8-1. EXPLODED VIEWS

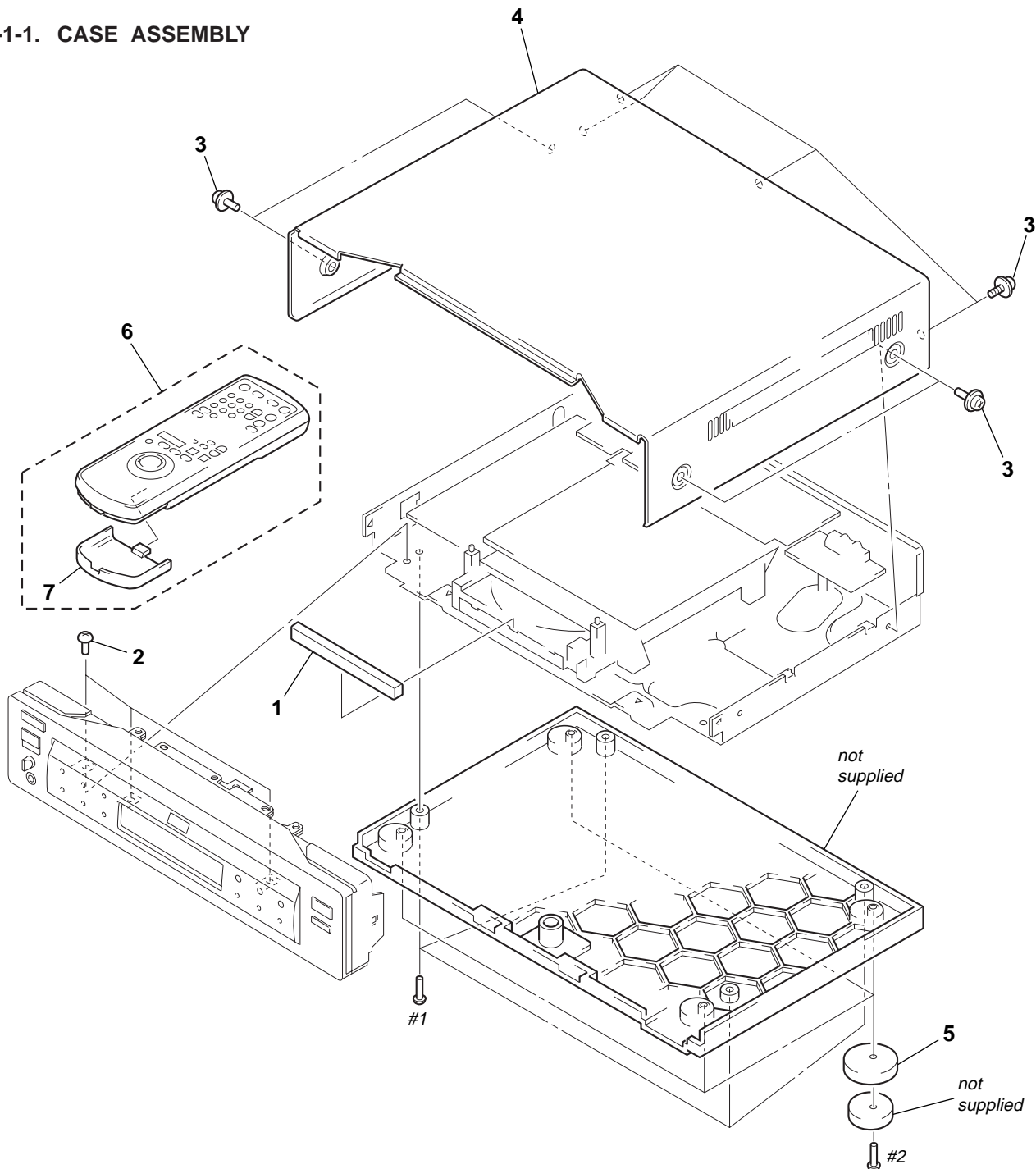
**NOTE:**

- -XX and -X mean standardized parts, so they may have some difference from the original one.
- Items marked "\*" are not stocked since they are seldom required for routine service. Some delay should be anticipated when ordering these items.
- Color Indication of Appearance Parts  
Example:  
KNOB, BALANCE (WHITE) . . . (RED)  
                                  ↑                                  ↑  
                                  Parts Color          Cabinet's Color
- The mechanical parts with no reference number in the exploded views are not supplied.
- Hardware (# mark) list and accessories and packing materials are given in the last of the electrical parts list.

The components identified by mark  $\Delta$  or dotted line with mark  $\Delta$  are critical for safety. Replace only with part number specified.

Les composants identifiés par une marque  $\Delta$  sont critiques pour la sécurité. Ne les remplacer que par une pièce portant le numéro spécifié.

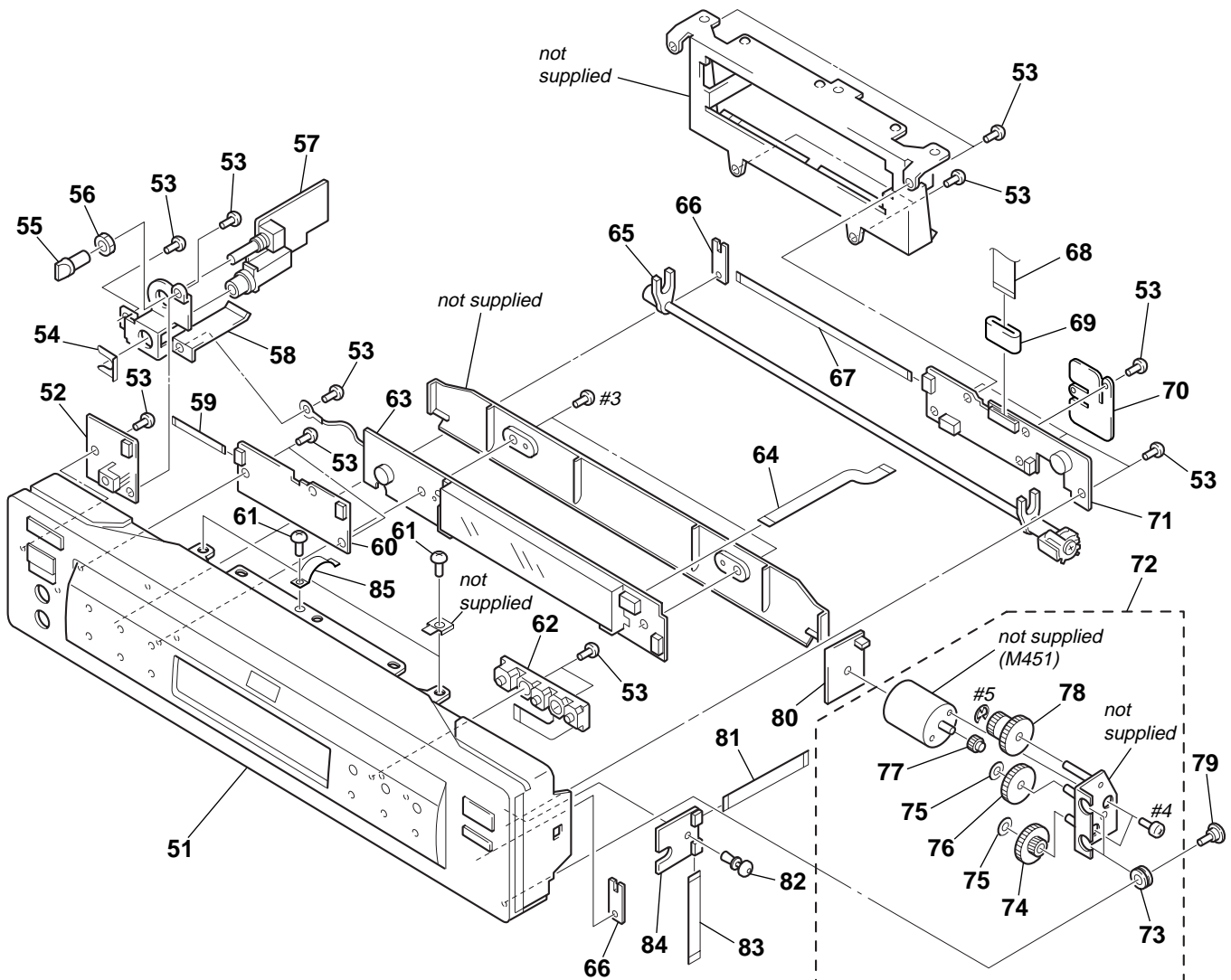
#### 8-1-1. CASE ASSEMBLY



Ref. No.	Part No.	Description	Remark	Ref. No.	Part No.	Description	Remark
1	3-052-655-01	COVER, TRAY		5	4-970-487-01	FOOT (F50180S)	
2	3-970-608-11	SUMITITE (B3), +BV		6	1-418-075-21	COMMANDER, STANDARD (RMT-D107A/B)	
3	3-710-901-41	SCREW, TAPPING		7	3-709-044-01	LID, BATTERY CASE (for RMT-D107A/B)	
4	3-052-658-01	CASE, UPPER					

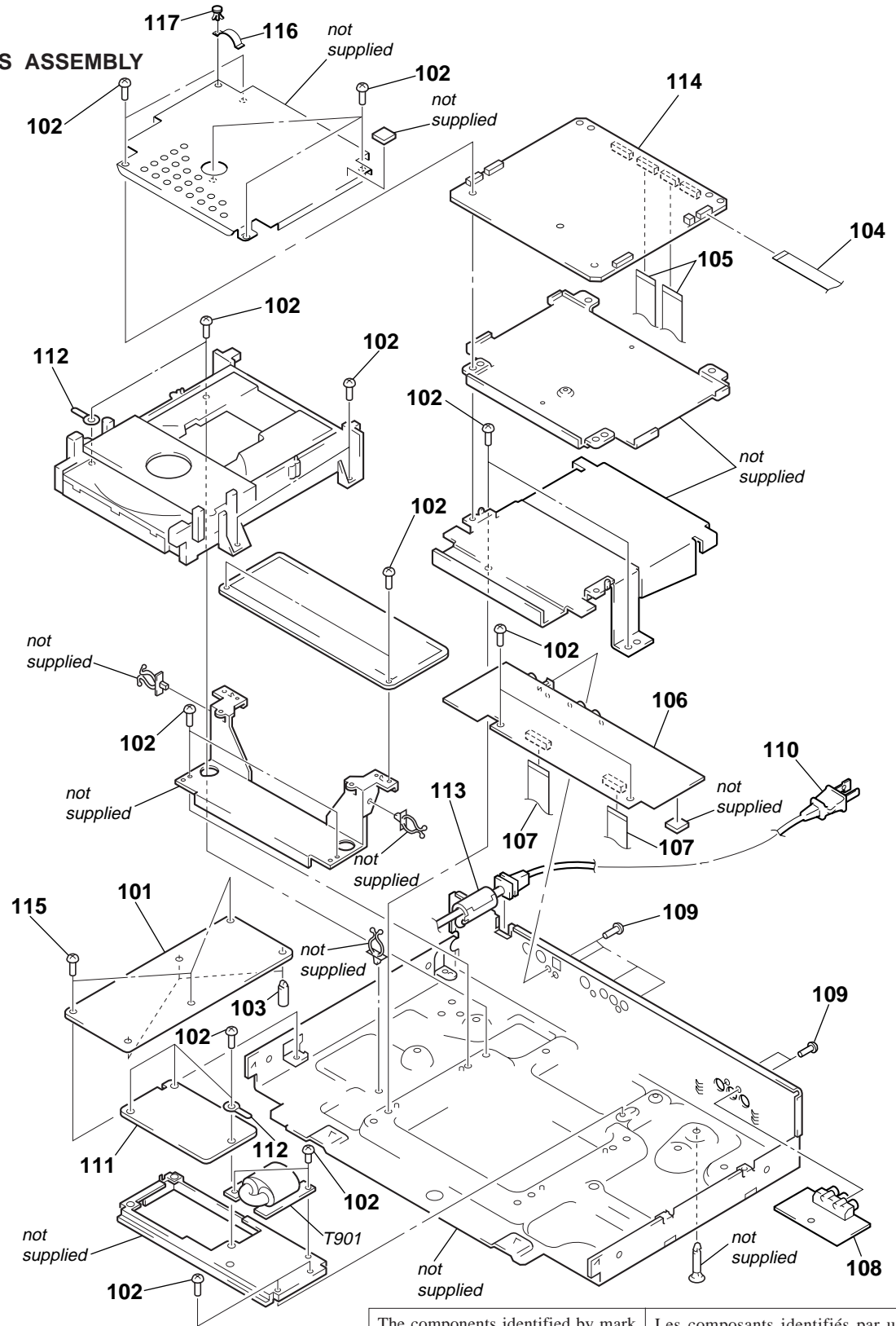


## 8-1-2. FRONT PANEL ASSEMBLY



Ref. No.	Part No.	Description	Remark	Ref. No.	Part No.	Description	Remark
51	A-6062-101-A	SUB BLOCK ASSY, FRONT PANEL		* 69	1-500-544-11	BEAD, FERRITE	
* 52	A-6065-166-A	PW-119 BOARD, COMPLETE		70	3-989-677-01	HOLDER	
53	4-951-620-01	SCREW (2.6X8), +BVTP		* 71	A-6065-164-A	FL-107 BOARD, COMPLETE	
* 54	3-684-436-01	PLATE, MOUNT		72	A-6062-008-A	DRIVING BLOCK ASSY, DOOR	
55	3-974-959-11	KNOB, VOLUME		73	3-570-118-00	CUSHION, MOTOR	
56	2-118-268-01	NUT (M9), HEXAGON		74	3-975-014-01	GEAR (B)	
* 57	A-6065-163-A	HP-119 BOARD, COMPLETE		75	3-377-720-01	WASHER, POLYETHYLENE	
58	3-052-659-01	BRACKET, HP		76	3-975-015-01	GEAR (C)	
59	1-790-144-11	CABLE, FLEXIBLE FLAT (FFP-11) (5P)		77	4-968-863-01	GEAR (A)	
* 60	A-6065-162-A	FR-159 BOARD, COMPLETE		78	3-975-016-01	GEAR (D)	
61	3-970-608-11	SUMITITE (B3), +BV		79	3-975-023-01	SCREW, CUSHION STOPPER	
62	1-475-109-11	SWITCH BLOCK, TOUCH		* 80	A-6065-167-A	CN-112 BOARD, COMPLETE	
* 63	A-6065-165-A	FP-60 BOARD, COMPLETE		81	1-782-197-11	CABLE, FLEXIBLE FLAT (FFD-1) (6P)	
64	1-671-924-11	FPL-1 FLEXIBLE BOARD		* 82	3-954-681-01	RIVET, NYLON	
65	A-6062-009-A	SHAFT ASSY, LINK		83	1-782-198-11	CABLE, FLEXIBLE FLAT (FDC-3) (3P)	
* 66	3-974-956-01	RETAINER, LINK SHAFT		* 84	A-6065-168-A	DR-87 BOARD, COMPLETE	
67	1-790-143-11	CABLE, FLEXIBLE FLAT (FLR-2) (6P)		85	3-051-301-01	SPRING, SHIELD	
68	1-790-140-11	CABLE, FLEXIBLE FLAT (FML-8) (20P)					

### 8-1-3. CHASSIS ASSEMBLY

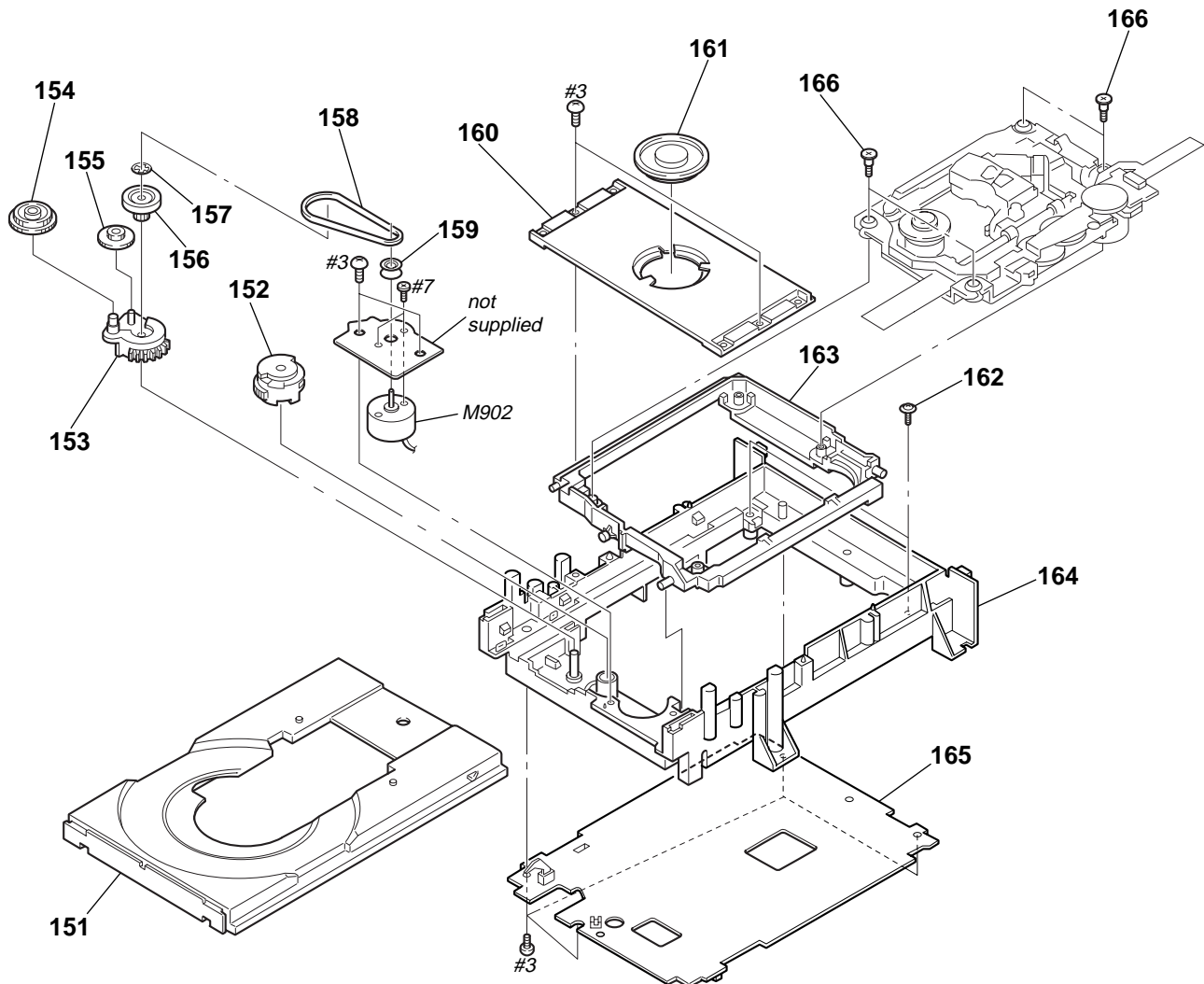


The components identified by mark Δ or dotted line with mark Δ are critical for safety. Replace only with part number specified.

Les composants identifiés par une marque Δ sont critiques pour la sécurité. Ne les remplacer que par une pièce portant le numéro spécifié.

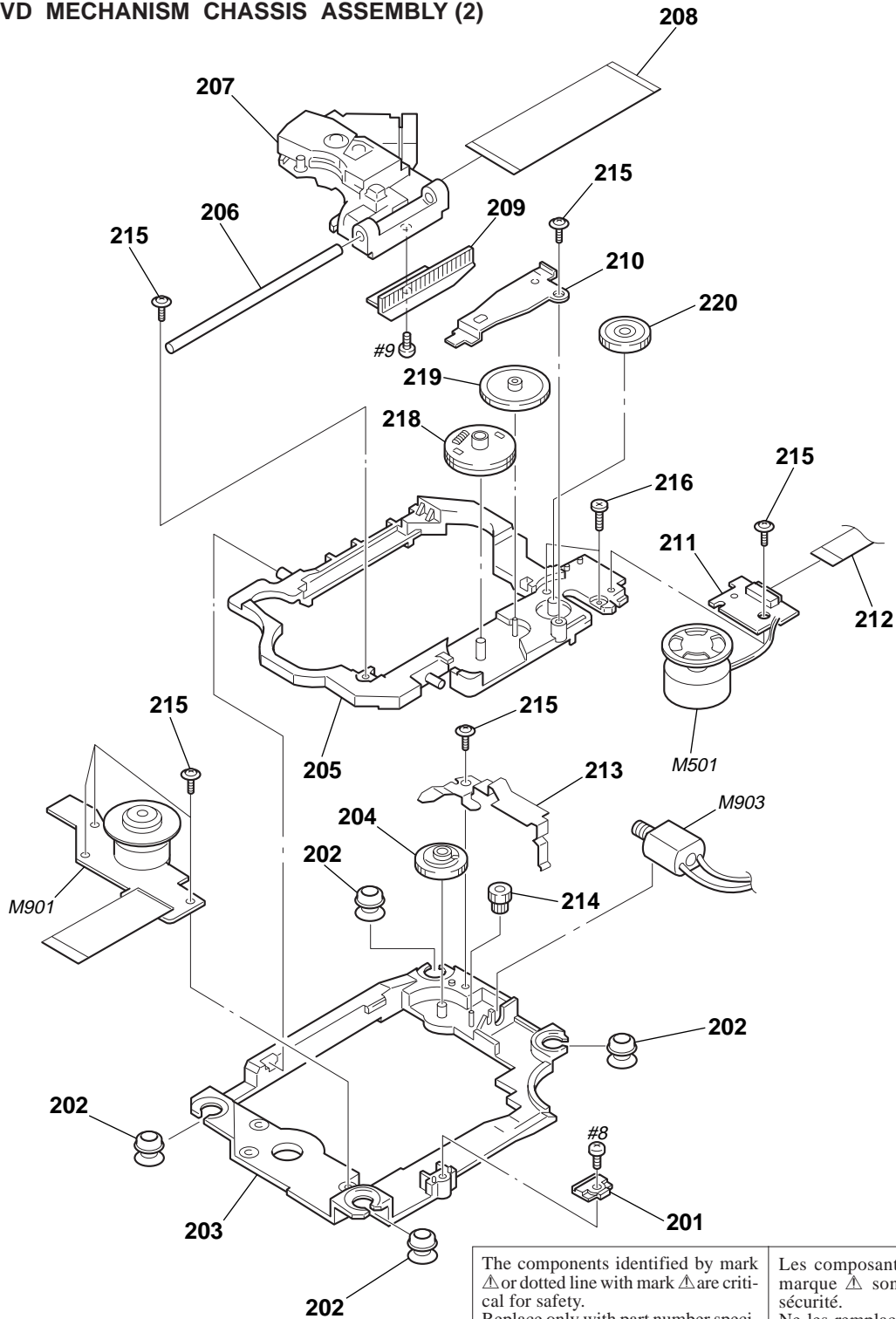
Ref. No.	Part No.	Description	Remark	Ref. No.	Part No.	Description	Remark
* 101	1-468-287-12	POWER BLOCK (HS-930SU)		Δ 110	1-790-154-11	CORD, POWER	
102	3-970-608-11	SUMITITE (B3), +BV		* 111	A-6065-173-A	PS-420 BOARD, COMPLETE	
* 103	3-691-950-01	SPACER, P. C. BOARD		* 112	3-703-150-11	CLAMP	
104	1-783-349-11	CABLE, FLEXIBLE FLAT (FMY-2) (9P)		113	1-500-386-11	FILTER, CLAMP (FERRITE CORE)	
105	1-783-339-11	CABLE, FLEXIBLE FLAT (FMT-21) (27P)		* 114	A-6065-169-A	MB-84 BOARD, COMPLETE	
* 106	A-6065-171-A	AU-218 BOARD, COMPLETE		115	3-050-569-01	SUMITITE (B3), +WHD	
107	1-783-343-11	CABLE, FLEXIBLE FLAT (FMA-4) (25P)		116	3-051-301-01	SPRING, SHIELD	
* 108	A-6065-172-A	YS-18 BOARD, COMPLETE		117	3-531-576-01	RIVET	
109	3-704-515-41	SCREW (BV/RING)		Δ T901	1-431-174-11	TRANSFORMER, POWER	

## 8-1-4. DVD MECHANISM CHASSIS ASSEMBLY (1)



Ref. No.	Part No.	Description	Remark	Ref. No.	Part No.	Description	Remark
151	3-973-099-01	TRAY (B)		160	3-975-089-01	BRACKET, PRESS PULLEY	
152	3-975-073-02	GEAR, CAM		* 161	3-975-074-01	PULLEY, PRESS	
153	3-975-087-01	GEAR, DRIVE		162	3-975-077-01	SCREW, BU STOPPER	
154	3-975-086-01	GEAR, TRAY DRIVING		* 163	3-975-088-01	HOLDER, BASE UNIT	
155	3-975-072-01	GEAR, LOADING (MIDWAY)		* 164	X-3948-398-1	HOLDER ASSY, MD	
156	3-975-071-01	PULLEY, LOADING		* 165	A-6065-077-A	TK-47 BOARD, COMPLETE	
157	3-669-596-00	WASHER (2.3), STOPPER		166	4-981-923-01	SCREW (M), STEP	
158	3-975-070-01	BELT		M902	1-698-942-21	MOTOR (LOADING)	
159	3-975-085-01	PULLEY, MOTOR					

8-1-5. DVD MECHANISM CHASSIS ASSEMBLY (2)



<p>The components identified by mark ▲ or dotted line with mark ▲ are critical for safety. Replace only with part number specified.</p>	<p>Les composants identifiés par une marque ▲ sont critiques pour la sécurité. Ne les remplacer que par une pièce portant le numéro spécifié.</p>
---	---

Ref. No.	Part No.	Description	Remark	Ref. No.	Part No.	Description	Remark
* 201	3-975-066-01	STOPPER, SKEW SHAFT		212	1-783-341-11	CABLE, FLAT (FMF-28) (8P)	
* 202	3-975-061-01	INSULATOR		* 213	3-975-059-01	RETAINER, SKEW GEAR	
* 203	3-975-056-01	BASE, SPINDLE		214	3-975-057-01	GEAR, SKEW	
204	3-975-058-01	CAM, SKEW		215	4-974-711-01	SCREW (2X5) (P TYIGHT), (+) PTTWH	
* 205	3-975-063-01	BASE, SLIDE		216	4-974-725-01	SCREW (M1.7X2.5), P	
* 206	3-975-065-01	SHAFT, MAIN		218	A-4683-008-A	GEAR ASSY, LIMITTER	
▲ 207	8-820-005-02	OPTICAL PICK-UP KHS-180A/J1N		219	4-974-720-01	GEAR (S-B)	
208	1-665-390-11	OP-15 FLEXIBLE BOARD		220	3-053-092-01	GEAR (S-A) (2)	
209	3-975-067-01	GEAR, RACK		M501	X-3947-137-1	MOTOR ASSY, SLED	
* 210	3-975-064-01	RETAINER, SLED GEAR		M901	1-698-944-11	MOTOR, DC (SPINDLE)	
* 211	A-6065-078-A	FG-43 BOARD, COMPLETE		M903	X-3947-138-1	MOTOR ASSY, SKEW (TILT)	

**8-2. ELECTRICAL PARTS LIST**

**NOTE:**

- Due to standardization, replacements in the parts list may be different from the parts specified in the diagrams or the components used on the set.
- -XX and -X mean standardized parts, so they may have some difference from the original one.
- **RESISTORS**  
All resistors are in ohms.  
METAL: Metal-film resistor.  
METAL OXIDE: Metal oxide-film resistor.  
F: nonflammable

- Items marked “\*” are not stocked since they are seldom required for routine service. Some delay should be anticipated when ordering these items.
- **SEMICONDUCTORS**  
In each case, u:  $\mu$ , for example:  
uA. . . :  $\mu$ A. . .    uPA. . . :  $\mu$ PA. . .  
uPB. . . :  $\mu$ PB. . .    uPC. . . :  $\mu$ PC. . .  
uPD. . . :  $\mu$ PD. . .
- **CAPACITORS**  
uF:  $\mu$ F
- **COILS**  
uH:  $\mu$ H

The components identified by mark  $\Delta$  or dotted line with mark  $\Delta$  are critical for safety. Replace only with part number specified.

Les composants identifiés par une marque  $\Delta$  sont critiques pour la sécurité. Ne les remplacer que par une pièce portant le numéro spécifié.

When indicating parts by reference number, please include the board.

Ref. No.	Part No.	Description	Remark	Ref. No.	Part No.	Description	Remark
*	A-6065-171-A	AU-218 BOARD, COMPLETE ***** (Ref.No.3,000 Series)		C242	1-124-910-11	ELECT 47uF 20%	50V
		< CAPACITOR >		C243	1-104-664-11	ELECT 47uF 20%	16V
C202	1-163-227-11	CERAMIC CHIP 10PF 0.5PF	50V	C244	1-124-701-51	ELECT 470uF 20%	25V
C203	1-163-227-11	CERAMIC CHIP 10PF 0.5PF	50V	C245	1-124-701-51	ELECT 470uF 20%	25V
C204	1-163-227-11	CERAMIC CHIP 10PF 0.5PF	50V	C247	1-104-665-11	ELECT 100uF 20%	10V
C206	1-126-052-11	ELECT 100uF 20%	50V	C248	1-104-665-11	ELECT 100uF 20%	10V
C207	1-128-200-11	ELECT 47uF 20%	50V	C249	1-126-925-11	ELECT 470uF 20%	10V
C208	1-126-052-11	ELECT 100uF 20%	50V	C250	1-126-925-11	ELECT 470uF 20%	10V
C209	1-163-231-11	CERAMIC CHIP 15PF 5%	50V	C252	1-104-664-11	ELECT 47uF 20%	16V
C210	1-163-009-11	CERAMIC CHIP 0.001uF 10%	50V	C253	1-164-004-11	CERAMIC CHIP 0.1uF 10%	25V
C211	1-136-850-11	FILM 0.1uF 5%	63V	C254	1-164-004-11	CERAMIC CHIP 0.1uF 10%	25V
C212	1-128-552-11	ELECT 47uF 20%	50V	C255	1-104-664-11	ELECT 47uF 20%	16V
C213	1-128-552-11	ELECT 47uF 20%	50V	C256	1-104-664-11	ELECT 47uF 20%	16V
C214	1-126-052-11	ELECT 100uF 20%	50V	C257	1-136-851-11	FILM 0.2uF 5%	63V
C215	1-127-805-21	FILM 5600PF 5%	50V	C258	1-136-851-11	FILM 0.2uF 5%	63V
C216	1-130-483-00	MYLAR 0.01uF 5%	50V	C260	1-136-850-11	FILM 0.1uF 5%	63V
C217	1-136-850-11	FILM 0.1uF 5%	63V	C261	1-136-850-11	FILM 0.1uF 5%	63V
C218	1-125-853-21	FILM 470PF 5%	50V	C266	1-163-259-91	CERAMIC CHIP 220PF 5%	50V
C219	1-109-894-11	ELECT 33uF 20%	10V	C267	1-128-200-11	ELECT 47uF 20%	63V
C220	1-127-805-21	FILM 5600PF 5%	50V	C268	1-136-851-11	FILM 0.2uF 5%	63V
C221	1-136-809-11	FILM 150PF 5%	100V	C269	1-136-851-11	FILM 0.2uF 5%	63V
C222	1-128-200-11	ELECT 47uF 20%	63V	C272	1-128-200-11	ELECT 47uF 20%	63V
C223	1-136-850-11	FILM 0.1uF 5%	63V	C367	1-163-009-11	CERAMIC CHIP 0.001uF 10%	50V
C224	1-136-850-11	FILM 0.1uF 5%	63V			< CONNECTOR >	
C225	1-125-853-21	FILM 470PF 5%	50V	CN201	1-770-653-11	CONNECTOR, FFC/FPC 25P	
C226	1-136-809-11	FILM 150PF 5%	100V	CN203	1-770-653-11	CONNECTOR, FFC/FPC 25P	
C227	1-128-200-11	ELECT 47uF 20%	63V	* CN204	1-564-510-11	PLUG, CONNECTOR 7P	
C228	1-124-721-11	ELECT 10uF 20%	50V	CN205	1-573-733-21	PIN, CONNECTOR 6P	
C229	1-124-721-11	ELECT 10uF 20%	50V			< DIODE >	
C230	1-136-850-11	FILM 0.1uF 5%	63V	D201	8-719-914-43	DIODE DAN202K-T-146	
C231	1-128-201-11	ELECT 100uF 20%	50V	D202	8-719-404-49	DIODE MA111	
C232	1-128-200-11	ELECT 47uF 20%	63V	D203	8-719-115-87	DIODE RD9.1JS-T4AB2	
C233	1-127-806-21	FILM 8200PF 5%	50V	D204	8-719-016-73	DIODE STZ6.8TT146	
C234	1-127-806-21	FILM 8200PF 5%	50V	D205	8-719-016-73	DIODE STZ6.8TT146	
C235	1-128-200-11	ELECT 47uF 20%	63V	D206	8-719-914-43	DIODE DAN202K-T-146	
C236	1-136-851-11	FILM 0.2uF 5%	63V	D207	8-719-016-73	DIODE STZ6.8TT146	
C237	1-136-851-11	FILM 0.2uF 5%	63V	D208	8-719-016-73	DIODE STZ6.8TT146	
C238	1-128-200-11	ELECT 47uF 20%	63V	D209	8-719-914-43	DIODE DAN202K-T-146	
C239	1-124-910-11	ELECT 47uF 20%	50V	D210	8-719-914-43	DIODE DAN202K-T-146	
C240	1-124-673-11	ELECT 100uF 20%	10V	D211	8-719-914-43	DIODE DAN202K-T-146	
C241	1-104-664-11	ELECT 47uF 20%	16V				

Ref. No.	Part No.	Description	Remark	Ref. No.	Part No.	Description	Remark
D214	8-719-404-49	DIODE MA111		L209	1-412-939-11	INDUCTOR 1uH	
D216	8-719-069-55	DIODE UDZS-TE17-5.6B		L210	1-414-926-21	INDUCTOR 0.47uH	
D352	8-719-067-40	DIODE STZ6.8N-T146				< TRANSISTOR >	
		< EARTH TERMINAL >					
* ET201	1-537-738-21	TERMINAL, EARTH		Q201	8-729-141-10	TRANSISTOR 2SA985A	
* ET202	1-537-738-21	TERMINAL, EARTH		Q202	8-729-141-58	TRANSISTOR 2SC2275A-QP	
		< FERRITE BEAD >		Q203	8-729-231-55	TRANSISTOR 2SC2878-AB	
				Q204	8-729-231-55	TRANSISTOR 2SC2878-AB	
FB201	1-414-553-11	FERRITE 0UH		Q205	8-729-424-18	TRANSISTOR UN2113	
FB202	1-414-553-11	FERRITE 0UH		Q206	8-729-224-62	TRANSISTOR 2SK246-GR	
FB203	1-414-553-11	FERRITE 0UH		Q207	8-729-421-19	TRANSISTOR UN2213	
FB204	1-414-135-11	FERRITE 0UH		Q208	8-729-421-19	TRANSISTOR UN2213	
FB205	1-414-135-11	FERRITE 0UH		Q209	8-729-424-18	TRANSISTOR UN2113	
				Q210	8-729-424-18	TRANSISTOR UN2113	
FB206	1-414-135-11	FERRITE 0UH		Q211	8-729-231-55	TRANSISTOR 2SC2878-AB	
FB207	1-414-135-11	FERRITE 0UH		Q212	8-729-231-55	TRANSISTOR 2SC2878-AB	
FB208	1-414-135-11	FERRITE 0UH		Q213	8-729-231-55	TRANSISTOR 2SC2878-AB	
FB209	1-414-135-11	FERRITE 0UH		Q214	8-729-424-08	TRANSISTOR UN2111	
FB210	1-414-553-11	FERRITE 0UH		Q215	8-729-421-19	TRANSISTOR UN2213	
				Q216	8-729-120-28	TRANSISTOR 2SC1623-L5L6	
FB211	1-414-553-11	FERRITE 0UH		Q217	8-729-424-18	TRANSISTOR UN2113	
FB212	1-414-553-11	FERRITE 0UH				< RESISTOR >	
FB213	1-414-553-11	FERRITE 0UH		R206	1-216-025-91	RES,CHIP 100 5% 1/10W	
FB214	1-216-295-91	SHORT 0		R207	1-216-025-91	RES,CHIP 100 5% 1/10W	
FB216	1-414-553-11	FERRITE 0UH		R208	1-216-025-91	RES,CHIP 100 5% 1/10W	
FB217	1-414-553-11	FERRITE 0UH		R209	1-216-025-91	RES,CHIP 100 5% 1/10W	
FB218	1-414-553-11	FERRITE 0UH		R211	1-216-073-00	METAL CHIP 10K 5% 1/10W	
FB219	1-414-553-11	FERRITE 0UH		R212	1-259-454-11	CARBON 12K 5% 1/6W	
FB221	1-414-553-11	FERRITE 0UH		R213	1-259-448-11	CARBON 6.8K 5% 1/6W	
FB222	1-414-553-11	FERRITE 0UH		R215	1-216-025-91	RES,CHIP 100 5% 1/10W	
FB223	1-414-553-11	FERRITE 0UH		R216	1-259-440-11	CARBON 3.3K 5% 1/6W	
FB224	1-414-553-11	FERRITE 0UH		R217	1-259-404-11	CARBON 100 5% 1/6W	
FB225	1-414-553-11	FERRITE 0UH		R218	1-259-440-11	CARBON 3.3K 5% 1/6W	
FB226	1-414-553-11	FERRITE 0UH		R219	1-216-049-91	RES,CHIP 1K 5% 1/10W	
FB227	1-414-553-11	FERRITE 0UH		R221	1-259-488-11	CARBON 330K 5% 1/6W	
FB228	1-414-553-11	FERRITE 0UH		R222	1-259-488-11	CARBON 330K 5% 1/6W	
FB351	1-414-553-11	FERRITE 0UH		R223	1-259-423-11	CARBON 620 5% 1/6W	
FB359	1-414-553-11	FERRITE 0UH		R224	1-259-434-11	CARBON 1.8K 5% 1/6W	
		< IC >		R225	1-259-404-11	CARBON 100 5% 1/6W	
				R226	1-259-452-11	CARBON 10K 5% 1/6W	
IC202	8-759-231-53	IC M5F7805		R227	1-259-452-11	CARBON 10K 5% 1/6W	
IC204	8-759-572-26	IC CXD8799N-T2		R228	1-259-452-11	CARBON 10K 5% 1/6W	
IC205	8-759-274-73	IC NJM5532M					
IC206	8-759-573-62	IC OPA2134PA		R229	1-259-434-11	CARBON 1.8K 5% 1/6W	
IC207	8-759-573-62	IC OPA2134PA		R230	1-259-423-11	CARBON 620 5% 1/6W	
				R231	1-259-452-11	CARBON 10K 5% 1/6W	
IC208	8-759-711-85	IC NJM4580E-D		R232	1-259-418-11	CARBON 390 5% 1/6W	
IC209	8-759-522-11	IC BA7660FS-E2		R233	1-259-420-11	CARBON 470 5% 1/6W	
IC210	8-749-921-12	IC GP1F32T (DIGITAL OUT OPTICAL)					
		< JACK >		R234	1-259-420-11	CARBON 470 5% 1/6W	
				R235	1-259-418-11	CARBON 390 5% 1/6W	
J202	1-694-409-31	TERMINAL BOARD (LINE OUT/S VIDEO OUT)		R236	1-259-466-11	CARBON 39K 5% 1/6W	
J203	1-779-382-21	JACK, PIN 1P (DIGITAL OUT COAXIAL)		R237	1-216-065-91	RES,CHIP 4.7K 5% 1/10W	
J352	1-764-188-21	JACK (SMALL TYPE) (DIA. 3.5) (S LINK)		R238	1-216-065-91	RES,CHIP 4.7K 5% 1/10W	
		< COIL >					
				R239	1-259-404-11	CARBON 100 5% 1/6W	
L204	1-408-615-31	INDUCTOR 100uH		R240	1-216-097-91	RES,CHIP 100K 5% 1/10W	
L205	1-414-930-21	INDUCTOR 2.2uH		R241	1-216-081-00	METAL CHIP 22K 5% 1/10W	
L206	1-414-930-21	INDUCTOR 2.2uH		R242	1-216-097-91	RES,CHIP 100K 5% 1/10W	
L207	1-412-951-11	INDUCTOR 10uH		R243	1-259-488-11	CARBON 330K 5% 1/6W	
L208	1-412-951-11	INDUCTOR 10uH					
				R244	1-259-488-11	CARBON 330K 5% 1/6W	
				R245	1-247-706-11	CARBON 330 5% 1/4W F	

**AU-218****CN-112****DR-87****FG-43****FL-107**

Ref. No.	Part No.	Description			Remark
R246	1-247-706-11	CARBON	330	5%	1/4W F
R247	1-216-097-91	RES,CHIP	100K	5%	1/10W
R248	1-216-025-91	RES,CHIP	100	5%	1/10W
R249	1-216-025-91	RES,CHIP	100	5%	1/10W
R251	1-216-065-91	RES,CHIP	4.7K	5%	1/10W
R252	1-216-025-91	RES,CHIP	100	5%	1/10W
R253	1-249-544-11	CARBON	470	5%	1/4W F
R254	1-249-544-11	CARBON	470	5%	1/4W F
R255	1-216-025-91	RES,CHIP	100	5%	1/10W
R257	1-216-073-00	METAL CHIP	10K	5%	1/10W
R258	1-216-073-00	METAL CHIP	10K	5%	1/10W
R259	1-216-069-00	METAL CHIP	6.8K	5%	1/10W
R261	1-216-073-00	METAL CHIP	10K	5%	1/10W
R262	1-216-057-00	METAL CHIP	2.2K	5%	1/10W
R263	1-216-073-00	METAL CHIP	10K	5%	1/10W
R264	1-249-544-11	CARBON	470	5%	1/4W F
R265	1-249-544-11	CARBON	470	5%	1/4W F
R266	1-208-754-11	METAL CHIP	68	0.5%	1/10W
R267	1-208-754-11	METAL CHIP	68	0.5%	1/10W
R268	1-208-754-11	METAL CHIP	68	0.5%	1/10W
R269	1-216-295-91	SHORT	0		
R270	1-216-073-00	METAL CHIP	10K	5%	1/10W
R271	1-216-295-91	SHORT	0		
R272	1-216-295-91	SHORT	0		
R273	1-216-295-91	SHORT	0		
R274	1-216-057-00	METAL CHIP	2.2K	5%	1/10W
R275	1-216-037-00	METAL CHIP	330	5%	1/10W
R276	1-216-037-00	METAL CHIP	330	5%	1/10W
R277	1-414-135-11	FERRITE	0uH		
R278	1-216-057-00	METAL CHIP	2.2K	5%	1/10W
R279	1-216-033-00	METAL CHIP	220	5%	1/10W
R280	1-216-021-00	METAL CHIP	68	5%	1/10W
R281	1-208-754-11	METAL CHIP	68	0.5%	1/10W
R282	1-208-754-11	METAL CHIP	68	0.5%	1/10W
R283	1-208-754-11	METAL CHIP	68	0.5%	1/10W
R284	1-216-025-91	RES,CHIP	100	5%	1/10W
R285	1-216-097-91	RES,CHIP	100K	5%	1/10W
R286	1-216-065-91	RES,CHIP	4.7K	5%	1/10W
R287	1-216-295-91	SHORT	0		
R288	1-216-109-00	METAL CHIP	330K	5%	1/10W
R289	1-216-109-00	METAL CHIP	330K	5%	1/10W
R298	1-216-295-91	SHORT	0		
R299	1-216-295-91	SHORT	0		
R301	1-216-025-91	RES,CHIP	100	5%	1/10W
R302	1-216-081-00	METAL CHIP	22K	5%	1/10W
R368	1-216-049-91	RES,CHIP	1K	5%	1/10W

*	A-6065-167-A	CN-112 BOARD, COMPLETE				
		*****				
						(Ref.No.1,000 Series)
		<CAPACITOR >				
C451	1-163-021-91	CERAMIC CHIP	0.01uF	10%	50V	
		< CONNECTOR >				
CN451	1-770-634-11	CONNECTOR, FFC/FPC 3P				

Ref. No.	Part No.	Description				Remark
*	A-6065-168-A	DR-87 BOARD, COMPLETE				
		*****				
						(Ref.No.1,000 Series)
		< CAPACITOR >				
C101	1-164-004-11	CERAMIC CHIP	0.1uF	10%	25V	
		< CONNECTOR >				
CN101	1-779-347-11	CONNECTOR, FFC/FPC 3P				
CN102	1-779-526-11	CONNECTOR, FFC/FPC 6P				
		< PHOTO INTERRUPTER >				
PH101	8-749-011-97	PHOTO INTERUPTER GP1S93				(DOOR SWITCH 1)
PH102	8-749-011-97	PHOTO INTERUPTER GP1S93				(DOOR SWITCH 2)
		< RESISTOR >				
R101	1-216-089-91	RES,CHIP	47K	5%	1/10W	
R103	1-216-037-00	METAL CHIP	330	5%	1/10W	
*	A-6065-078-A	FG-43 BOARD, COMPLETE				
		*****				
						(Ref.No.1,000 Series)
		< CONNECTOR >				
CN501	1-784-684-11	CONNECTOR, FFC/FPC 8P				
		< IC >				
IC501	8-719-052-42	IC ELEMENT, HOLE HW-108A-FT (D)				
IC502	8-719-052-42	IC ELEMENT, HOLE HW-108A-FT (D)				
*	A-6065-164-A	FL-107 BOARD, COMPLETE				
		*****				
						(Ref.No.1,000 Series)
		< BUZZER >				
BZ151	1-529-080-11	BUZZER, PIEZOELECTRIC				
		< CAPACITOR >				
C151	1-164-004-11	CERAMIC CHIP	0.1uF	10%	25V	
C152	1-164-004-11	CERAMIC CHIP	0.1uF	10%	25V	
C153	1-164-004-11	CERAMIC CHIP	0.1uF	10%	25V	
C154	1-164-004-11	CERAMIC CHIP	0.1uF	10%	25V	
		< CONNECTOR >				
CN151	1-779-526-11	CONNECTOR, FFC/FPC 6P				
CN153	1-770-703-11	CONNECTOR, FFC/FPC 20P				
CN154	1-779-526-11	CONNECTOR, FFC/FPC 6P				
		< FUSE >				
△F151	1-533-771-21	FUSE (SMD) (0.8A)				
		< FERRITE BEAD >				
FB151	1-414-553-11	FERRITE	0UH			
FB152	1-414-553-11	FERRITE	0UH			
* FB153	1-500-449-21	FERRITE	0UH			

The components identified by mark  $\Delta$  or dotted line with mark  $\Delta$  are critical for safety. Replace only with part number specified.

Les composants identifiés par une marque  $\Delta$  sont critiques pour la sécurité. Ne les remplacer que par une pièce portant le numéro spécifié.

Ref. No.	Part No.	Description	Remark	Ref. No.	Part No.	Description	Remark
		< IC >				< CONNECTOR >	
IC151	8-759-823-87	IC LB1638M		CN201	1-779-345-11	CONNECTOR, FFC/FPC 7P	
		< TRANSISTOR >		CN202	1-770-889-11	SOCKET, CONNECTOR 8P	
Q151	8-729-421-19	TRANSISTOR UN2213				< DIODE >	
		< RESISTOR >		D201	8-719-056-07	DIODE SLR-342MCT31 (DTS)	
R151	1-216-077-00	METAL CHIP	15K 5% 1/10W	D204	8-719-420-14	DIODE MA8082-M	
R152	1-216-071-00	METAL CHIP	8.2K 5% 1/10W	D205	8-719-977-69	DIODE DTZ24B	
R153	1-216-065-91	RES,CHIP	4.7K 5% 1/10W	D206	8-719-210-39	DIODE EC10QS-04	
R154	1-216-001-00	METAL CHIP	10 5% 1/10W	D209	8-719-404-49	DIODE MA111	
R155	1-216-001-00	METAL CHIP	10 5% 1/10W			< FILTER >	
R156	1-216-055-00	METAL CHIP	1.8K 5% 1/10W	FL201	1-233-893-21	FILTER, CHIP EMI	
R157	1-216-061-00	METAL CHIP	3.3K 5% 1/10W			< IC >	
R158	1-216-049-91	RES,CHIP	1K 5% 1/10W	IC201	8-759-438-82	IC uPD16311GC-AB6	
R159	1-216-059-00	METAL CHIP	2.7K 5% 1/10W			< COIL >	
R160	1-216-053-00	METAL CHIP	1.5K 5% 1/10W	L201	1-412-058-11	INDUCTOR CHIP 10uH	
R161	1-216-049-91	RES,CHIP	1K 5% 1/10W	L202	1-412-058-11	INDUCTOR CHIP 10uH	
R162	1-216-055-00	METAL CHIP	1.8K 5% 1/10W	L203	1-412-058-11	INDUCTOR CHIP 10uH	
R163	1-216-053-00	METAL CHIP	1.5K 5% 1/10W	L204	1-412-058-11	INDUCTOR CHIP 10uH	
R164	1-216-065-91	RES,CHIP	4.7K 5% 1/10W	L205	1-414-936-21	INDUCTOR 22uH	
R165	1-216-025-91	RES,CHIP	100 5% 1/10W			< FLUORECENT INDICATOR >	
R166	1-216-025-91	RES,CHIP	100 5% 1/10W	ND201	1-517-715-11	INDICATOR TUBE, FLUORESCENT	
R167	1-216-025-91	RES,CHIP	100 5% 1/10W			< TRANSISTOR >	
R168	1-216-025-91	RES,CHIP	100 5% 1/10W	Q202	8-729-105-29	TRANSISTOR 2SA1385	
		< SWITCH >		Q203	8-729-216-22	TRANSISTOR 2SA1162	
S151	1-771-349-21	SWITCH, KEYBOARD (LEFT)				< RESISTOR >	
S152	1-771-349-21	SWITCH, KEYBOARD (DOWN)		R201	1-216-033-00	METAL CHIP 220 5% 1/10W	
S153	1-771-349-21	SWITCH, KEYBOARD (UP)		R203	1-216-025-91	RES,CHIP 100 5% 1/10W	
S154	1-771-349-21	SWITCH, KEYBOARD (RIGHT)		R204	1-216-067-00	METAL CHIP 5.6K 5% 1/10W	
S155	1-771-349-21	SWITCH, KEYBOARD (TITLE)		R205	1-216-073-00	METAL CHIP 10K 5% 1/10W	
S156	1-771-349-21	SWITCH, KEYBOARD (ENTER)		R206	1-216-073-00	METAL CHIP 10K 5% 1/10W	
S157	1-771-349-21	SWITCH, KEYBOARD (DVD MENU)		R207	1-216-073-00	METAL CHIP 10K 5% 1/10W	
S158	1-771-349-21	SWITCH, KEYBOARD (PANEL)		R208	1-216-073-00	METAL CHIP 10K 5% 1/10W	
S159	1-771-349-21	SWITCH, KEYBOARD (RETURN)		R209	1-216-037-00	METAL CHIP 330 5% 1/10W	
S160	1-771-349-21	SWITCH, KEYBOARD (OPEN/CLOSE)		R210	1-216-049-91	RES,CHIP 1K 5% 1/10W	
* A-6065-165-A	FP-60 BOARD, COMPLETE	*****	(Ref.No.1,000 Series)	R211	1-216-091-00	METAL CHIP 56K 5% 1/10W	
3-884-241-01	SHEET (C), ADHESIVE			R215	1-216-073-00	METAL CHIP 10K 5% 1/10W	
	< CAPACITOR >			R216	1-216-073-00	METAL CHIP 10K 5% 1/10W	
C201	1-126-205-11	ELECT CHIP	47uF 20% 6.3V	R217	1-216-073-00	METAL CHIP 10K 5% 1/10W	
C202	1-163-021-91	CERAMIC CHIP	0.01uF 10% 50V	R219	1-216-063-91	RES,CHIP 3.9K 5% 1/10W	
C203	1-126-205-11	ELECT CHIP	47uF 20% 6.3V	R221	1-216-025-91	RES,CHIP 100 5% 1/10W	
C204	1-164-004-11	CERAMIC CHIP	0.1uF 10% 25V	R222	1-216-025-91	RES,CHIP 100 5% 1/10W	
C205	1-126-400-11	ELECT	22uF 20% 35V	R223	1-216-025-91	RES,CHIP 100 5% 1/10W	
C206	1-126-603-11	ELECT CHIP	4.7uF 20% 35V	R224	1-216-009-00	METAL CHIP 22 5% 1/10W	
C207	1-164-489-11	CERAMIC CHIP	0.22uF 10% 16V	R225	1-216-063-91	RES,CHIP 3.9K 5% 1/10W	
C208	1-163-259-91	CERAMIC CHIP	220PF 5% 50V	R226	1-216-077-00	METAL CHIP 15K 5% 1/10W	
C209	1-164-004-11	CERAMIC CHIP	0.1uF 10% 25V	R227	1-216-061-00	METAL CHIP 3.3K 5% 1/10W	
C210	1-126-204-11	ELECT CHIP	47uF 20% 16V	R229	1-216-083-00	METAL CHIP 27K 5% 1/10W	
C211	1-163-021-91	CERAMIC CHIP	0.01uF 10% 50V			< TRANSFORMER >	
C212	1-126-603-11	ELECT CHIP	4.7uF 20% 35V	T201	1-431-778-11	TRANSFORMER, DC-DC CONVERTER	



<b>FR-159</b>	<b>HP-119</b>	<b>MB-84</b>
---------------	---------------	--------------

Ref. No.	Part No.	Description	Remark
*	A-6065-162-A	FR-159 BOARD, COMPLETE ***** (Ref.No.1,000 Series)	
		< CONNECTOR >	
CN401	1-779-526-11	CONNECTOR, FFC/FPC 6P	
CN402	1-770-688-11	CONNECTOR, FFC/FPC 5P	
		< RESISTOR >	
R401	1-216-071-00	METAL CHIP 8.2K 5% 1/10W	
R402	1-216-065-91	RES,CHIP 4.7K 5% 1/10W	
R403	1-216-061-00	METAL CHIP 3.3K 5% 1/10W	
R404	1-216-059-00	METAL CHIP 2.7K 5% 1/10W	
		< SWITCH >	
S401	1-771-349-21	SWITCH, KEYBOARD (SET UP)	
S402	1-771-349-21	SWITCH, KEYBOARD (DNR)	
S403	1-771-349-21	SWITCH, KEYBOARD (PREV)	
S404	1-771-349-21	SWITCH, KEYBOARD (NEXT)	
<hr/>			
*	A-6065-163-A	HP-119 BOARD, COMPLETE ***** (Ref.No.1,000 Series)	
		< CAPACITOR >	
C002	1-163-011-11	CERAMIC CHIP 0.0015uF 10% 50V	
C003	1-163-011-11	CERAMIC CHIP 0.0015uF 10% 50V	
C008	1-163-021-91	CERAMIC CHIP 0.01uF 10% 50V	
C009	1-163-021-91	CERAMIC CHIP 0.01uF 10% 50V	
C012	1-126-925-11	ELECT 470uF 20% 10V	
C013	1-126-925-11	ELECT 470uF 20% 10V	
C014	1-164-506-11	CERAMIC CHIP 4.7uF 16V	
C015	1-164-506-11	CERAMIC CHIP 4.7uF 16V	
		< CONNECTOR >	
CN002	1-573-733-11	PIN, CONNECTOR 6P	
		< DIODE >	
D002	8-719-016-73	DIODE STZ6.8TT146	
D003	8-719-016-73	DIODE STZ6.8TT146	
		< FERRITE BEAD >	
FB001	1-414-135-11	FERRITE 0UH	
FB002	1-414-135-11	FERRITE 0UH	
FB003	1-414-135-11	FERRITE 0UH	
		< IC >	
IC001	8-759-369-74	IC NJM4556AM-TE2	
		< JACK >	
J001	1-785-505-21	JACK, LARGE TYPE (PHONES)	
		< TRANSISTOR >	
Q001	8-729-023-22	TRANSISTOR 2SD2114KT146	
Q002	8-729-023-22	TRANSISTOR 2SD2114KT146	
		< RESISTOR >	
R001	1-216-295-91	SHORT 0	
R002	1-216-295-91	SHORT 0	

Ref. No.	Part No.	Description	Remark
R003	1-216-029-00	METAL CHIP 150 5% 1/10W	
R004	1-216-029-00	METAL CHIP 150 5% 1/10W	
R005	1-216-049-91	RES,CHIP 1K 5% 1/10W	
R006	1-216-049-91	RES,CHIP 1K 5% 1/10W	
R007	1-216-089-91	RES,CHIP 47K 5% 1/10W	
R008	1-216-089-91	RES,CHIP 47K 5% 1/10W	
R009	1-216-081-00	METAL CHIP 22K 5% 1/10W	
R010	1-216-081-00	METAL CHIP 22K 5% 1/10W	
R011	1-216-049-91	RES,CHIP 1K 5% 1/10W	
R012	1-216-049-91	RES,CHIP 1K 5% 1/10W	
		< VARIABLE RESISTOR >	
RV001	1-225-746-11	RES, VAR (PHONE LEVEL)	
<hr/>			
*	A-6065-169-A	MB-84 BOARD, COMPLETE ***** (Ref.No.2,000 Series)	
*	3-709-100-01	COVER, IC SOCKET	
		< CAPACITOR >	
C002	1-126-206-11	ELECT CHIP 100uF 20% 6.3V	
C003	1-126-206-11	ELECT CHIP 100uF 20% 6.3V	
C004	1-126-204-11	ELECT CHIP 47uF 20% 16V	
C005	1-126-204-11	ELECT CHIP 47uF 20% 16V	
C006	1-126-204-11	ELECT CHIP 47uF 20% 16V	
C007	1-126-206-11	ELECT CHIP 100uF 20% 6.3V	
C008	1-126-206-11	ELECT CHIP 100uF 20% 6.3V	
C009	1-107-682-11	CERAMIC CHIP 1uF 10% 16V	
C010	1-107-682-11	CERAMIC CHIP 1uF 10% 16V	
C011	1-126-206-11	ELECT CHIP 100uF 20% 6.3V	
C012	1-126-206-11	ELECT CHIP 100uF 20% 6.3V	
C015	1-126-204-11	ELECT CHIP 47uF 20% 16V	
C016	1-126-206-11	ELECT CHIP 100uF 20% 6.3V	
C017	1-126-206-11	ELECT CHIP 100uF 20% 6.3V	
C018	1-126-204-11	ELECT CHIP 47uF 20% 16V	
C021	1-126-204-11	ELECT CHIP 47uF 20% 16V	
C023	1-126-206-11	ELECT CHIP 100uF 20% 6.3V	
C025	1-126-204-11	ELECT CHIP 47uF 20% 16V	
C026	1-126-206-11	ELECT CHIP 100uF 20% 6.3V	
C031	1-126-206-11	ELECT CHIP 100uF 20% 6.3V	
C200	1-162-970-11	CERAMIC CHIP 0.01uF 10% 25V	
C201	1-126-206-11	ELECT CHIP 100uF 20% 6.3V	
C202	1-162-970-11	CERAMIC CHIP 0.01uF 10% 25V	
C203	1-162-970-11	CERAMIC CHIP 0.01uF 10% 25V	
C204	1-162-970-11	CERAMIC CHIP 0.01uF 10% 25V	
C205	1-162-970-11	CERAMIC CHIP 0.01uF 10% 25V	
C206	1-162-970-11	CERAMIC CHIP 0.01uF 10% 25V	
C207	1-162-970-11	CERAMIC CHIP 0.01uF 10% 25V	
C208	1-162-970-11	CERAMIC CHIP 0.01uF 10% 25V	
C209	1-162-970-11	CERAMIC CHIP 0.01uF 10% 25V	
C210	1-162-970-11	CERAMIC CHIP 0.01uF 10% 25V	
C211	1-162-970-11	CERAMIC CHIP 0.01uF 10% 25V	
C214	1-162-970-11	CERAMIC CHIP 0.01uF 10% 25V	
C215	1-162-964-11	CERAMIC CHIP 0.001uF 10% 50V	
C216	1-162-970-11	CERAMIC CHIP 0.01uF 10% 25V	
C217	1-162-970-11	CERAMIC CHIP 0.01uF 10% 25V	
C218	1-162-970-11	CERAMIC CHIP 0.01uF 10% 25V	
C219	1-128-004-11	ELECT CHIP 10uF 20% 16V	
C220	1-162-970-11	CERAMIC CHIP 0.01uF 10% 25V	

Ref. No.	Part No.	Description			Remark	Ref. No.	Part No.	Description			Remark
C221	1-162-970-11	CERAMIC CHIP	0.01uF	10%	25V	C327	1-162-970-11	CERAMIC CHIP	0.01uF	10%	25V
C222	1-162-970-11	CERAMIC CHIP	0.01uF	10%	25V	C328	1-107-826-11	CERAMIC CHIP	0.1uF	10%	16V
C224	1-162-970-11	CERAMIC CHIP	0.01uF	10%	25V	C329	1-162-970-11	CERAMIC CHIP	0.01uF	10%	25V
C226	1-162-970-11	CERAMIC CHIP	0.01uF	10%	25V	C330	1-107-826-11	CERAMIC CHIP	0.1uF	10%	16V
C227	1-162-970-11	CERAMIC CHIP	0.01uF	10%	25V	C331	1-107-826-11	CERAMIC CHIP	0.1uF	10%	16V
C228	1-162-970-11	CERAMIC CHIP	0.01uF	10%	25V	C332	1-107-826-11	CERAMIC CHIP	0.1uF	10%	16V
C229	1-126-204-11	ELECT CHIP	47uF	20%	16V	C333	1-162-970-11	CERAMIC CHIP	0.01uF	10%	25V
C231	1-162-970-11	CERAMIC CHIP	0.01uF	10%	25V	C334	1-107-826-11	CERAMIC CHIP	0.1uF	10%	16V
C232	1-162-916-11	CERAMIC CHIP	12PF	5%	50V	C335	1-126-204-11	ELECT CHIP	47uF	20%	16V
C233	1-162-970-11	CERAMIC CHIP	0.01uF	10%	25V	C336	1-162-970-11	CERAMIC CHIP	0.01uF	10%	25V
C234	1-162-970-11	CERAMIC CHIP	0.01uF	10%	25V	C337	1-126-204-11	ELECT CHIP	47uF	20%	16V
C235	1-126-204-11	ELECT CHIP	47uF	20%	16V	C338	1-107-826-11	CERAMIC CHIP	0.1uF	10%	16V
C236	1-162-970-11	CERAMIC CHIP	0.01uF	10%	25V	C339	1-162-970-11	CERAMIC CHIP	0.01uF	10%	25V
C237	1-162-970-11	CERAMIC CHIP	0.01uF	10%	25V	C340	1-128-004-11	ELECT CHIP	10uF	20%	16V
C238	1-126-204-11	ELECT CHIP	47uF	20%	16V	C341	1-128-357-11	ELECT CHIP	10uF	20%	16V
C240	1-126-206-11	ELECT CHIP	100uF	20%	6.3V	C342	1-162-970-11	CERAMIC CHIP	0.01uF	10%	25V
C250	1-162-970-11	CERAMIC CHIP	0.01uF	10%	25V	C343	1-162-970-11	CERAMIC CHIP	0.01uF	10%	25V
C251	1-162-970-11	CERAMIC CHIP	0.01uF	10%	25V	C344	1-162-970-11	CERAMIC CHIP	0.01uF	10%	25V
C252	1-128-004-11	ELECT CHIP	10uF	20%	16V	C361	1-162-964-11	CERAMIC CHIP	0.001uF	10%	50V
C253	1-162-970-11	CERAMIC CHIP	0.01uF	10%	25V	C362	1-162-970-11	CERAMIC CHIP	0.01uF	10%	25V
C254	1-162-970-11	CERAMIC CHIP	0.01uF	10%	25V	C363	1-128-004-11	ELECT CHIP	10uF	20%	16V
C255	1-162-970-11	CERAMIC CHIP	0.01uF	10%	25V	C365	1-162-970-11	CERAMIC CHIP	0.01uF	10%	25V
C256	1-162-970-11	CERAMIC CHIP	0.01uF	10%	25V	C366	1-128-004-11	ELECT CHIP	10uF	20%	16V
C257	1-128-004-11	ELECT CHIP	10uF	20%	16V	C367	1-107-826-11	CERAMIC CHIP	0.1uF	10%	16V
C258	1-162-970-11	CERAMIC CHIP	0.01uF	10%	25V	C368	1-107-826-11	CERAMIC CHIP	0.1uF	10%	16V
C259	1-128-004-11	ELECT CHIP	10uF	20%	16V	C369	1-107-826-11	CERAMIC CHIP	0.1uF	10%	16V
C260	1-162-970-11	CERAMIC CHIP	0.01uF	10%	25V	C370	1-107-826-11	CERAMIC CHIP	0.1uF	10%	16V
C261	1-162-970-11	CERAMIC CHIP	0.01uF	10%	25V	C372	1-162-970-11	CERAMIC CHIP	0.01uF	10%	25V
C262	1-162-970-11	CERAMIC CHIP	0.01uF	10%	25V	C373	1-128-004-11	ELECT CHIP	10uF	20%	16V
C263	1-162-970-11	CERAMIC CHIP	0.01uF	10%	25V	C378	1-107-826-11	CERAMIC CHIP	0.1uF	10%	16V
C264	1-107-826-11	CERAMIC CHIP	0.1uF	10%	16V	C379	1-107-826-11	CERAMIC CHIP	0.1uF	10%	16V
C265	1-162-970-11	CERAMIC CHIP	0.01uF	10%	25V	C380	1-107-826-11	CERAMIC CHIP	0.1uF	10%	16V
C266	1-162-970-11	CERAMIC CHIP	0.01uF	10%	25V	C381	1-107-826-11	CERAMIC CHIP	0.1uF	10%	16V
C267	1-107-826-11	CERAMIC CHIP	0.1uF	10%	16V	C382	1-107-826-11	CERAMIC CHIP	0.1uF	10%	16V
C268	1-107-826-11	CERAMIC CHIP	0.1uF	10%	16V	C383	1-107-826-11	CERAMIC CHIP	0.1uF	10%	16V
C269	1-162-970-11	CERAMIC CHIP	0.01uF	10%	25V	C384	1-107-826-11	CERAMIC CHIP	0.1uF	10%	16V
C270	1-162-917-11	CERAMIC CHIP	15PF	5%	50V	C385	1-107-826-11	CERAMIC CHIP	0.1uF	10%	16V
C271	1-162-917-11	CERAMIC CHIP	15PF	5%	50V	C386	1-128-004-11	ELECT CHIP	10uF	20%	16V
C272	1-162-917-11	CERAMIC CHIP	15PF	5%	50V	C387	1-107-682-11	CERAMIC CHIP	1uF	10%	16V
C282	1-107-826-11	CERAMIC CHIP	0.1uF	10%	16V	C388	1-162-928-11	CERAMIC CHIP	120PF	5%	50V
C301	1-162-967-11	CERAMIC CHIP	0.0033uF	10%	50V	C389	1-162-927-11	CERAMIC CHIP	100PF	5%	50V
C303	1-126-193-11	ELECT	1uF	20%	50V	C390	1-110-563-11	CERAMIC CHIP	0.068uF	10%	16V
C304	1-162-967-11	CERAMIC CHIP	0.0033uF	10%	50V	C391	1-110-563-11	CERAMIC CHIP	0.068uF	10%	16V
C305	1-165-176-11	CERAMIC CHIP	0.047uF	10%	16V	C392	1-162-957-11	CERAMIC CHIP	220PF	5%	50V
C306	1-162-970-11	CERAMIC CHIP	0.01uF	10%	25V	C393	1-162-957-11	CERAMIC CHIP	220PF	5%	50V
C309	1-164-245-11	CERAMIC CHIP	0.015uF	10%	25V	C394	1-164-473-11	CERAMIC CHIP	820PF	10%	50V
C310	1-162-967-11	CERAMIC CHIP	0.0033uF	10%	50V	C395	1-164-473-11	CERAMIC CHIP	820PF	10%	50V
C312	1-164-489-11	CERAMIC CHIP	0.22uF	10%	16V	C396	1-164-473-11	CERAMIC CHIP	820PF	10%	50V
C313	1-162-967-11	CERAMIC CHIP	0.0033uF	10%	50V	C397	1-164-473-11	CERAMIC CHIP	820PF	10%	50V
C314	1-162-968-11	CERAMIC CHIP	0.0047uF	10%	50V	C454	1-162-970-11	CERAMIC CHIP	0.01uF	10%	25V
C315	1-162-968-11	CERAMIC CHIP	0.0047uF	10%	50V	C466	1-162-970-11	CERAMIC CHIP	0.01uF	10%	25V
C317	1-162-967-11	CERAMIC CHIP	0.0033uF	10%	50V	C467	1-162-970-11	CERAMIC CHIP	0.01uF	10%	25V
C318	1-162-967-11	CERAMIC CHIP	0.0033uF	10%	50V	C468	1-128-004-11	ELECT CHIP	10uF	20%	16V
C319	1-162-970-11	CERAMIC CHIP	0.01uF	10%	25V	C469	1-162-970-11	CERAMIC CHIP	0.01uF	10%	25V
C320	1-162-967-11	CERAMIC CHIP	0.0033uF	10%	50V	C470	1-107-826-11	CERAMIC CHIP	0.1uF	10%	16V
C321	1-162-970-11	CERAMIC CHIP	0.01uF	10%	25V	C502	1-162-964-11	CERAMIC CHIP	0.001uF	10%	50V
C322	1-162-967-11	CERAMIC CHIP	0.0033uF	10%	50V	C503	1-124-778-00	ELECT CHIP	22uF	20%	6.3V
C324	1-162-967-11	CERAMIC CHIP	0.0033uF	10%	50V	C504	1-107-826-11	CERAMIC CHIP	0.1uF	10%	16V
C325	1-165-176-11	CERAMIC CHIP	0.047uF	10%	16V	C506	1-162-964-11	CERAMIC CHIP	0.001uF	10%	50V
C326	1-128-004-11	ELECT CHIP	10uF	20%	16V	C507	1-162-959-11	CERAMIC CHIP	330PF	5%	50V

**MB-84**

Ref. No.	Part No.	Description	Remark			Ref. No.	Part No.	Description	Remark		
C510	1-107-826-11	CERAMIC CHIP	0.1uF	10%	16V	C617	1-162-970-11	CERAMIC CHIP	0.01uF	10%	25V
C511	1-162-925-11	CERAMIC CHIP	68PF	5%	50V	C618	1-126-205-11	ELECT CHIP	47uF	20%	6.3V
C512	1-162-968-11	CERAMIC CHIP	0.0047uF	10%	50V	C620	1-162-970-11	CERAMIC CHIP	0.01uF	10%	25V
C513	1-115-412-11	CERAMIC CHIP	680PF	5%	25V	C621	1-162-970-11	CERAMIC CHIP	0.01uF	10%	25V
C514	1-162-957-11	CERAMIC CHIP	220PF	5%	50V	C629	1-162-970-11	CERAMIC CHIP	0.01uF	10%	25V
C516	1-164-245-11	CERAMIC CHIP	0.015uF	10%	25V	C630	1-162-964-11	CERAMIC CHIP	0.001uF	10%	50V
C517	1-164-489-11	CERAMIC CHIP	0.22uF	10%	16V	C800	1-162-970-11	CERAMIC CHIP	0.01uF	10%	25V
C518	1-162-970-11	CERAMIC CHIP	0.01uF	10%	25V	C801	1-162-970-11	CERAMIC CHIP	0.01uF	10%	25V
C520	1-162-968-11	CERAMIC CHIP	0.0047uF	10%	50V	C802	1-162-970-11	CERAMIC CHIP	0.01uF	10%	25V
C521	1-162-964-11	CERAMIC CHIP	0.001uF	10%	50V	C803	1-162-970-11	CERAMIC CHIP	0.01uF	10%	25V
C522	1-162-927-11	CERAMIC CHIP	100PF	5%	50V	C804	1-162-970-11	CERAMIC CHIP	0.01uF	10%	25V
C524	1-107-826-11	CERAMIC CHIP	0.1uF	10%	16V	C805	1-162-970-11	CERAMIC CHIP	0.01uF	10%	25V
C525	1-165-176-11	CERAMIC CHIP	0.047uF	10%	16V	C806	1-162-970-11	CERAMIC CHIP	0.01uF	10%	25V
C526	1-107-826-11	CERAMIC CHIP	0.1uF	10%	16V	C807	1-162-970-11	CERAMIC CHIP	0.01uF	10%	25V
C528	1-162-970-11	CERAMIC CHIP	0.01uF	10%	25V	C808	1-162-970-11	CERAMIC CHIP	0.01uF	10%	25V
C529	1-164-227-11	CERAMIC CHIP	0.022uF	10%	25V	C809	1-162-970-11	CERAMIC CHIP	0.01uF	10%	25V
C530	1-164-217-11	CERAMIC CHIP	150PF	5%	50V	C810	1-162-970-11	CERAMIC CHIP	0.01uF	10%	25V
C531	1-162-964-11	CERAMIC CHIP	0.001uF	10%	50V	C811	1-162-917-11	CERAMIC CHIP	15PF	5%	50V
C532	1-162-970-11	CERAMIC CHIP	0.01uF	10%	25V	C812	1-162-917-11	CERAMIC CHIP	15PF	5%	50V
C533	1-128-004-11	ELECT CHIP	10uF	20%	16V	C813	1-162-970-11	CERAMIC CHIP	0.01uF	10%	25V
C534	1-162-970-11	CERAMIC CHIP	0.01uF	10%	25V	C814	1-162-970-11	CERAMIC CHIP	0.01uF	10%	25V
C535	1-162-970-11	CERAMIC CHIP	0.01uF	10%	25V	C815	1-162-970-11	CERAMIC CHIP	0.01uF	10%	25V
C537	1-128-004-11	ELECT CHIP	10uF	20%	16V	C816	1-110-563-11	CERAMIC CHIP	0.068uF	10%	16V
C538	1-107-826-11	CERAMIC CHIP	0.1uF	10%	16V	C817	1-107-826-11	CERAMIC CHIP	0.1uF	10%	16V
C539	1-107-826-11	CERAMIC CHIP	0.1uF	10%	16V	C818	1-107-826-11	CERAMIC CHIP	0.1uF	10%	16V
C540	1-162-970-11	CERAMIC CHIP	0.01uF	10%	25V	C819	1-107-826-11	CERAMIC CHIP	0.1uF	10%	16V
C541	1-128-004-11	ELECT CHIP	10uF	20%	16V	C820	1-107-826-11	CERAMIC CHIP	0.1uF	10%	16V
C542	1-107-826-11	CERAMIC CHIP	0.1uF	10%	16V	C821	1-107-826-11	CERAMIC CHIP	0.1uF	10%	16V
C543	1-128-004-11	ELECT CHIP	10uF	20%	16V	C822	1-107-826-11	CERAMIC CHIP	0.1uF	10%	16V
C544	1-162-970-11	CERAMIC CHIP	0.01uF	10%	25V	C823	1-162-927-11	CERAMIC CHIP	100PF	5%	50V
C545	1-162-970-11	CERAMIC CHIP	0.01uF	10%	25V	C824	1-162-970-11	CERAMIC CHIP	0.01uF	10%	25V
C546	1-162-970-11	CERAMIC CHIP	0.01uF	10%	25V	C825	1-162-970-11	CERAMIC CHIP	0.01uF	10%	25V
C547	1-162-970-11	CERAMIC CHIP	0.01uF	10%	25V	C826	1-162-970-11	CERAMIC CHIP	0.01uF	10%	25V
C548	1-128-004-11	ELECT CHIP	10uF	20%	16V	C827	1-162-970-11	CERAMIC CHIP	0.01uF	10%	25V
C549	1-107-826-11	CERAMIC CHIP	0.1uF	10%	16V	C828	1-162-970-11	CERAMIC CHIP	0.01uF	10%	25V
C550	1-107-826-11	CERAMIC CHIP	0.1uF	10%	16V	C829	1-162-970-11	CERAMIC CHIP	0.01uF	10%	25V
C551	1-107-826-11	CERAMIC CHIP	0.1uF	10%	16V	C830	1-162-970-11	CERAMIC CHIP	0.01uF	10%	25V
C552	1-124-778-00	ELECT CHIP	22uF	20%	6.3V	C831	1-162-970-11	CERAMIC CHIP	0.01uF	10%	25V
C555	1-162-970-11	CERAMIC CHIP	0.01uF	10%	25V	C832	1-162-970-11	CERAMIC CHIP	0.01uF	10%	25V
C556	1-162-970-11	CERAMIC CHIP	0.01uF	10%	25V	C833	1-162-970-11	CERAMIC CHIP	0.01uF	10%	25V
C558	1-164-489-11	CERAMIC CHIP	0.22uF	10%	16V	C834	1-162-970-11	CERAMIC CHIP	0.01uF	10%	25V
C559	1-162-970-11	CERAMIC CHIP	0.01uF	10%	25V	C835	1-162-970-11	CERAMIC CHIP	0.01uF	10%	25V
C560	1-162-970-11	CERAMIC CHIP	0.01uF	10%	25V	C836	1-162-970-11	CERAMIC CHIP	0.01uF	10%	25V
C561	1-162-970-11	CERAMIC CHIP	0.01uF	10%	25V	C837	1-162-970-11	CERAMIC CHIP	0.01uF	10%	25V
C562	1-162-970-11	CERAMIC CHIP	0.01uF	10%	25V	C838	1-162-970-11	CERAMIC CHIP	0.01uF	10%	25V
C601	1-162-970-11	CERAMIC CHIP	0.01uF	10%	25V	C839	1-162-970-11	CERAMIC CHIP	0.01uF	10%	25V
C602	1-162-970-11	CERAMIC CHIP	0.01uF	10%	25V	C840	1-162-970-11	CERAMIC CHIP	0.01uF	10%	25V
C603	1-162-970-11	CERAMIC CHIP	0.01uF	10%	25V	C841	1-162-970-11	CERAMIC CHIP	0.01uF	10%	25V
C604	1-162-970-11	CERAMIC CHIP	0.01uF	10%	25V	C842	1-162-970-11	CERAMIC CHIP	0.01uF	10%	25V
C605	1-162-970-11	CERAMIC CHIP	0.01uF	10%	25V	C843	1-162-970-11	CERAMIC CHIP	0.01uF	10%	25V
C606	1-162-970-11	CERAMIC CHIP	0.01uF	10%	25V	C844	1-164-677-11	CERAMIC CHIP	0.033uF	10%	16V
C607	1-162-970-11	CERAMIC CHIP	0.01uF	10%	25V	C846	1-128-004-11	ELECT CHIP	10uF	20%	16V
C608	1-162-970-11	CERAMIC CHIP	0.01uF	10%	25V	C847	1-128-004-11	ELECT CHIP	10uF	20%	16V
C609	1-162-970-11	CERAMIC CHIP	0.01uF	10%	25V	C848	1-128-004-11	ELECT CHIP	10uF	20%	16V
C610	1-162-970-11	CERAMIC CHIP	0.01uF	10%	25V	C849	1-126-206-11	ELECT CHIP	100uF	20%	6.3V
C611	1-162-970-11	CERAMIC CHIP	0.01uF	10%	25V	C850	1-126-206-11	ELECT CHIP	100uF	20%	6.3V
C612	1-162-970-11	CERAMIC CHIP	0.01uF	10%	25V	C851	1-128-004-11	ELECT CHIP	10uF	20%	16V
C613	1-162-970-11	CERAMIC CHIP	0.01uF	10%	25V	C852	1-162-970-11	CERAMIC CHIP	0.01uF	10%	25V
C614	1-162-970-11	CERAMIC CHIP	0.01uF	10%	25V	C854	1-128-004-11	ELECT CHIP	10uF	20%	16V
C615	1-162-970-11	CERAMIC CHIP	0.01uF	10%	25V	C855	1-162-970-11	CERAMIC CHIP	0.01uF	10%	25V

Ref. No.	Part No.	Description	Remark	Ref. No.	Part No.	Description	Remark
C856	1-162-970-11	CERAMIC CHIP 0.01uF 10% 25V		FB605	1-414-553-11	FERRITE OUH	
C857	1-162-970-11	CERAMIC CHIP 0.01uF 10% 25V		FB606	1-414-553-11	FERRITE OUH	
C858	1-162-970-11	CERAMIC CHIP 0.01uF 10% 25V		FB607	1-414-553-11	FERRITE OUH	
C859	1-162-970-11	CERAMIC CHIP 0.01uF 10% 25V		FB608	1-414-553-11	FERRITE OUH	
C860	1-162-970-11	CERAMIC CHIP 0.01uF 10% 25V		FB609	1-414-553-11	FERRITE OUH	
C861	1-162-970-11	CERAMIC CHIP 0.01uF 10% 25V		FB611	1-414-553-11	FERRITE OUH	
C862	1-162-970-11	CERAMIC CHIP 0.01uF 10% 25V		* FB704	1-500-449-21	FERRITE OUH	
C863	1-162-970-11	CERAMIC CHIP 0.01uF 10% 25V		* FB705	1-500-449-21	FERRITE OUH	
C864	1-126-206-11	ELECT CHIP 100uF 20% 6.3V		* FB706	1-500-449-21	FERRITE OUH	
C865	1-162-970-11	CERAMIC CHIP 0.01uF 10% 25V		* FB707	1-500-449-21	FERRITE OUH	
< CONNECTOR >				* FB708	1-500-449-21	FERRITE OUH	
CN001	1-778-768-21	PIN, CONNECTOR (PC BOARD) 8P		* FB710	1-500-449-21	FERRITE OUH	
CN002	1-784-687-41	PIN, CONNECTOR (PC BOARD) 7P		* FB711	1-500-449-21	FERRITE OUH	
CN101	1-774-769-11	CONNECTOR, FFC/FPC 25P		* FB712	1-500-449-21	FERRITE OUH	
CN251	1-770-692-11	CONNECTOR, FFC/FPC 9P		* FB713	1-500-449-21	FERRITE OUH	
CN252	1-774-769-11	CONNECTOR, FFC/FPC 25P		* FB714	1-500-449-21	FERRITE OUH	
CN301	1-784-684-11	CONNECTOR, FFC/FPC 8P		* FB715	1-500-449-21	FERRITE OUH	
CN302	1-784-326-11	CONNECTOR, FFC/FPC 27P		* FB801	1-500-449-21	FERRITE OUH	
CN303	1-573-290-21	PIN, CONNECTOR (1.5MM) (SMD) 4P		* FB802	1-500-449-21	FERRITE OUH	
CN361	1-784-688-21	PIN, CONNECTOR (PC BOARD) 2P		FB803	1-500-283-11	INDUCTOR CHIP OUH	
CN451	1-573-768-21	PIN, CONNECTOR (1.5MM) (SMD) 5P		< FILTER >			
CN452	1-784-326-11	CONNECTOR, FFC/FPC 27P		FL001	1-233-893-21	FILTER, CHIP EMI	
* CN601	1-580-802-21	SOCKET, CONNECTOR 20P		FL002	1-233-893-21	FILTER, CHIP EMI	
CN801	1-573-806-21	PIN, CONNECTOR (1.5MM) (SMD) 6P		FL003	1-233-893-21	FILTER, CHIP EMI	
< TRIMMER >				FL004	1-233-893-21	FILTER, CHIP EMI	
CT201	1-141-423-61	CAP, ADJ 20PF (SYS CLK (27MHz) ADJ)		FL005	1-233-893-21	FILTER, CHIP EMI	
< DIODE >				FL006	1-233-893-21	FILTER, CHIP EMI	
D002	8-719-975-40	DIODE RB411D		FL007	1-233-893-21	FILTER, CHIP EMI	
D101	8-719-988-62	DIODE 1SS355		FL008	1-233-893-21	FILTER, CHIP EMI	
D102	8-719-988-62	DIODE 1SS355		FL201	1-233-893-21	FILTER, CHIP EMI	
D103	8-719-988-62	DIODE 1SS355		FL202	1-233-893-21	FILTER, CHIP EMI	
D502	8-719-988-62	DIODE 1SS355		FL204	1-239-400-11	FILTER, CHIP EMI	
D503	8-719-060-48	DIODE RB751V-40TE-17		FL205	1-239-400-11	FILTER, CHIP EMI	
D601	8-719-988-62	DIODE 1SS355		FL207	1-239-400-11	FILTER, CHIP EMI	
D602	8-719-988-62	DIODE 1SS355		FL208	1-233-893-21	FILTER, CHIP EMI	
D801	8-719-988-62	DIODE 1SS355		FL209	1-239-400-11	FILTER, CHIP EMI	
D802	8-719-048-98	DIODE RB160L-40TE25		FL210	1-239-400-11	FILTER, CHIP EMI	
D803	8-719-988-62	DIODE 1SS355		FL211	1-233-893-21	FILTER, CHIP EMI	
< FUSE >				FL212	1-233-893-21	FILTER, CHIP EMI	
△ F001	1-533-771-21	FUSE (SMD) (0.8A)		FL213	1-239-400-11	FILTER, CHIP EMI	
△ F002	1-533-771-21	FUSE (SMD) (0.8A)		FL251	1-233-893-21	FILTER, CHIP EMI	
△ F003	1-533-771-21	FUSE (SMD) (0.8A)		FL252	1-233-893-21	FILTER, CHIP EMI	
△ F004	1-533-771-21	FUSE (SMD) (0.8A)		FL254	1-233-893-21	FILTER, CHIP EMI	
△ F005	1-533-710-11	FUSE (SMD) (1.6A)		FL501	1-233-893-21	FILTER, CHIP EMI	
△ F006	1-533-710-11	FUSE (SMD) (1.6A)		FL502	1-233-893-21	FILTER, CHIP EMI	
< FERRITE BEAD >				FL601	1-233-893-21	FILTER, CHIP EMI	
FB201	1-414-580-21	INDUCTOR 100NH		FL801	1-233-893-21	FILTER, CHIP EMI	
FB601	1-414-553-11	FERRITE OUH		FL802	1-233-893-21	FILTER, CHIP EMI	
FB602	1-414-553-11	FERRITE OUH		FL803	1-233-893-21	FILTER, CHIP EMI	
* FB603	1-500-449-21	FERRITE OUH		FL804	1-233-893-21	FILTER, CHIP EMI	
FB604	1-414-553-11	FERRITE OUH		FL805	1-233-893-21	FILTER, CHIP EMI	
< IC >				FL806	1-233-893-21	FILTER, CHIP EMI	
IC201	8-759-564-80	IC MN4SV17160BT-10		FL807	1-233-893-21	FILTER, CHIP EMI	
				FL808	1-233-893-21	FILTER, CHIP EMI	

The components identified by mark △ or dotted line with △ are critical for safety. Replace only with part number specified.	Les composants identifiés par une marque △ sont critiques pour la sécurité. Ne les remplacer que par une pièce portant le numéro spécifié.
---	--

**MB-84**

Ref. No.	Part No.	Description	Remark	Ref. No.	Part No.	Description	Remark
IC202	8-759-564-80	IC MN4SV17160BT-10		Q602	8-729-424-18	TRANSISTOR UN2113	
IC203	8-759-526-72	IC L64021-A-QC-27				< RESISTOR >	
IC204	8-759-531-92	IC TC7WH04FU (TE12R)					
IC205	8-759-456-81	IC SN74ABT126DB-E20		R001	1-216-827-11	METAL CHIP 3.3K	5% 1/16W
IC206	8-759-456-81	IC SN74ABT126DB-E20		R002	1-216-296-91	SHORT 0	
IC207	8-759-522-14	IC MB90096PF-G-127-BND-ER		R004	1-216-820-11	METAL CHIP 820	5% 1/16W
IC208	8-759-058-62	IC TC7S08FU (TE85R)		R005	1-216-837-11	METAL CHIP 22K	5% 1/16W
IC209	8-759-522-10	IC CXD8696R-T2		R008	1-216-833-11	METAL CHIP 10K	5% 1/16W
IC251	8-752-384-09	IC CXD1854Q		R009	1-216-821-11	METAL CHIP 1K	5% 1/16W
IC252	8-752-379-07	IC CXD1914Q		R027	1-216-864-11	METAL CHIP 0	5% 1/16W
IC301	8-759-701-39	IC NJM3404AM		R031	1-216-864-11	METAL CHIP 0	5% 1/16W
IC302	8-759-384-55	IC LA6527N-TE-B		R051	1-218-831-11	RES,CHIP 220	0.50% 1/16W
IC303	8-759-333-63	IC LB1896-TE-B		R052	1-218-831-11	RES,CHIP 220	0.50% 1/16W
IC361	8-759-490-71	IC BA5912AFP-YE2		R053	1-218-831-11	RES,CHIP 220	0.50% 1/16W
IC363	8-759-522-13	IC BA5981FP-E2		R054	1-218-831-11	RES,CHIP 220	0.50% 1/16W
IC452	8-759-441-31	IC MC14053BDTR2		R055	1-218-831-11	RES,CHIP 220	0.50% 1/16W
IC455	8-759-100-93	IC uPC393G2		R056	1-218-831-11	RES,CHIP 220	0.50% 1/16W
IC501	8-759-100-93	IC uPC393G2		R057	1-216-805-11	METAL CHIP 47	5% 1/16W
IC502	8-759-701-36	IC NJM3403AM (TE2)		R062	1-216-864-11	METAL CHIP 0	5% 1/16W
IC503	8-759-701-36	IC NJM3403AM (TE2)		R138	1-216-864-11	METAL CHIP 0	5% 1/16W
IC506	8-759-525-61	IC CXD8730R		R139	1-216-864-11	METAL CHIP 0	5% 1/16W
IC507	8-759-701-39	IC NJM3404AM		R144	1-216-864-11	METAL CHIP 0	5% 1/16W
IC508	8-759-701-39	IC NJM3404AM		R145	1-216-864-11	METAL CHIP 0	5% 1/16W
IC601	8-759-926-66	IC SN74HC373ANS		R146	1-216-864-11	METAL CHIP 0	5% 1/16W
IC602	8-759-082-55	IC TC7W00FU (TE12R)		R148	1-216-864-11	METAL CHIP 0	5% 1/16W
IC603	8-759-570-15	IC MSM27C401CZ-H01TS-K		R149	1-216-864-11	METAL CHIP 0	5% 1/16W
IC604	8-759-426-60	IC MB90T678PF-G-BND		R150	1-216-864-11	METAL CHIP 0	5% 1/16W
IC605	8-759-434-20	IC PST572DML-L		R151	1-216-864-11	METAL CHIP 0	5% 1/16W
IC606	8-759-100-93	IC uPC393G2		R152	1-216-833-11	METAL CHIP 10K	5% 1/16W
IC801	8-759-431-99	IC BR9020F-E2		R153	1-216-864-11	METAL CHIP 0	5% 1/16W
IC802	8-759-553-30	IC KM681000CLG-5T		R154	1-216-864-11	METAL CHIP 0	5% 1/16W
IC803	8-759-546-58	IC MBM29F800BA-90PF		R155	1-216-864-11	METAL CHIP 0	5% 1/16W
IC804	8-759-525-66	IC CXD8728Q		R156	1-216-864-11	METAL CHIP 0	5% 1/16W
IC805	8-759-489-89	IC HD6437034AD49F		R157	1-216-864-11	METAL CHIP 0	5% 1/16W
IC806	8-759-522-09	IC CXD1865R		R158	1-216-864-11	METAL CHIP 0	5% 1/16W
IC807	8-759-526-79	IC CXD8747Q		R159	1-216-864-11	METAL CHIP 0	5% 1/16W
IC810	8-759-567-35	IC KM416V1200CT-L6T		R160	1-216-864-11	METAL CHIP 0	5% 1/16W
IC811	8-752-390-59	IC CXD1904Q		R161	1-216-864-11	METAL CHIP 0	5% 1/16W
IC812	8-759-486-55	IC NJM2370U33-TE2		R162	1-216-864-11	METAL CHIP 0	5% 1/16W
		< IC SOCKET >		R163	1-216-864-11	METAL CHIP 0	5% 1/16W
* ICS803	1-251-496-21	SOCKET, IC		R164	1-216-864-11	METAL CHIP 0	5% 1/16W
		< COIL >		R165	1-216-864-11	METAL CHIP 0	5% 1/16W
L001	1-409-529-41	INDUCTOR 0uH		R166	1-216-864-11	METAL CHIP 0	5% 1/16W
L002	1-409-529-41	INDUCTOR 0uH		R167	1-216-864-11	METAL CHIP 0	5% 1/16W
L004	1-409-529-41	INDUCTOR 0uH		R168	1-216-864-11	METAL CHIP 0	5% 1/16W
L005	1-409-529-41	INDUCTOR 0uH		R169	1-216-864-11	METAL CHIP 0	5% 1/16W
L006	1-409-529-41	INDUCTOR 0uH		R170	1-216-864-11	METAL CHIP 0	5% 1/16W
L007	1-409-529-41	INDUCTOR 0uH		R171	1-216-864-11	METAL CHIP 0	5% 1/16W
L205	1-412-935-11	INDUCTOR 0.47uH		R172	1-216-864-11	METAL CHIP 0	5% 1/16W
		< TRANSISTOR >		R173	1-216-864-11	METAL CHIP 0	5% 1/16W
Q001	8-729-230-63	TRANSISTOR 2SC4116-YG		R174	1-216-864-11	METAL CHIP 0	5% 1/16W
Q002	8-729-044-78	TRANSISTOR 2SJ327-Z-E1		R175	1-216-864-11	METAL CHIP 0	5% 1/16W
Q371	8-729-015-76	TRANSISTOR UN5211-TX		R176	1-216-832-11	METAL CHIP 8.2K	5% 1/16W
Q372	8-729-015-76	TRANSISTOR UN5211-TX		R177	1-216-829-11	METAL CHIP 4.7K	5% 1/16W
Q452	8-729-023-22	TRANSISTOR 2SD2114KT146		R178	1-216-825-11	METAL CHIP 2.2K	5% 1/16W
Q501	8-729-015-76	TRANSISTOR UN5211-TX		R179	1-216-809-11	METAL CHIP 100	5% 1/16W
Q601	8-729-216-22	TRANSISTOR 2SA1162		R180	1-216-864-11	METAL CHIP 0	5% 1/16W
				R181	1-216-864-11	METAL CHIP 0	5% 1/16W
				R194	1-216-805-11	METAL CHIP 47	5% 1/16W
				R195	1-216-805-11	METAL CHIP 47	5% 1/16W

<u>Ref. No.</u>	<u>Part No.</u>	<u>Description</u>			<u>Remark</u>	<u>Ref. No.</u>	<u>Part No.</u>	<u>Description</u>			<u>Remark</u>
R196	1-216-805-11	METAL CHIP	47	5%	1/16W	R262	1-216-805-11	METAL CHIP	47	5%	1/16W
R197	1-216-805-11	METAL CHIP	47	5%	1/16W	R263	1-216-805-11	METAL CHIP	47	5%	1/16W
R198	1-216-805-11	METAL CHIP	47	5%	1/16W	R264	1-216-805-11	METAL CHIP	47	5%	1/16W
R199	1-216-805-11	METAL CHIP	47	5%	1/16W	R265	1-216-805-11	METAL CHIP	47	5%	1/16W
R200	1-216-801-11	METAL CHIP	22	5%	1/16W	R266	1-216-805-11	METAL CHIP	47	5%	1/16W
R202	1-216-805-11	METAL CHIP	47	5%	1/16W	R267	1-216-805-11	METAL CHIP	47	5%	1/16W
R203	1-216-805-11	METAL CHIP	47	5%	1/16W	R268	1-216-805-11	METAL CHIP	47	5%	1/16W
R204	1-216-805-11	METAL CHIP	47	5%	1/16W	R269	1-216-805-11	METAL CHIP	47	5%	1/16W
R205	1-216-864-11	METAL CHIP	0	5%	1/16W	R270	1-216-821-11	METAL CHIP	1K	5%	1/16W
R207	1-216-805-11	METAL CHIP	47	5%	1/16W	R279	1-216-813-11	METAL CHIP	220	5%	1/16W
R208	1-216-805-11	METAL CHIP	47	5%	1/16W	R280	1-216-809-11	METAL CHIP	100	5%	1/16W
R209	1-216-805-11	METAL CHIP	47	5%	1/16W	R281	1-216-801-11	METAL CHIP	22	5%	1/16W
R210	1-216-805-11	METAL CHIP	47	5%	1/16W	R282	1-216-801-11	METAL CHIP	22	5%	1/16W
R211	1-216-805-11	METAL CHIP	47	5%	1/16W	R283	1-216-805-11	METAL CHIP	47	5%	1/16W
R212	1-216-809-11	METAL CHIP	100	5%	1/16W	R284	1-216-805-11	METAL CHIP	47	5%	1/16W
R213	1-216-809-11	METAL CHIP	100	5%	1/16W	R285	1-216-805-11	METAL CHIP	47	5%	1/16W
R214	1-216-805-11	METAL CHIP	47	5%	1/16W	R286	1-216-827-11	METAL CHIP	3.3K	5%	1/16W
R215	1-216-805-11	METAL CHIP	47	5%	1/16W	R290	1-216-829-11	METAL CHIP	4.7K	5%	1/16W
R216	1-216-809-11	METAL CHIP	100	5%	1/16W	R291	1-216-805-11	METAL CHIP	47	5%	1/16W
R218	1-216-805-11	METAL CHIP	47	5%	1/16W	R293	1-216-864-11	METAL CHIP	0	5%	1/16W
R219	1-216-801-11	METAL CHIP	22	5%	1/16W	R294	1-216-864-11	METAL CHIP	0	5%	1/16W
R220	1-216-801-11	METAL CHIP	22	5%	1/16W	R296	1-216-809-11	METAL CHIP	100	5%	1/16W
R221	1-216-801-11	METAL CHIP	22	5%	1/16W	R297	1-216-864-11	METAL CHIP	0	5%	1/16W
R222	1-216-813-11	METAL CHIP	220	5%	1/16W	R298	1-216-809-11	METAL CHIP	100	5%	1/16W
R223	1-216-805-11	METAL CHIP	47	5%	1/16W	R299	1-216-864-11	METAL CHIP	0	5%	1/16W
R224	1-216-805-11	METAL CHIP	47	5%	1/16W	R301	1-216-833-11	METAL CHIP	10K	5%	1/16W
R225	1-216-805-11	METAL CHIP	47	5%	1/16W	R302	1-216-845-11	METAL CHIP	100K	5%	1/16W
R226	1-216-805-11	METAL CHIP	47	5%	1/16W	R304	1-216-841-11	METAL CHIP	47K	5%	1/16W
R227	1-216-805-11	METAL CHIP	47	5%	1/16W	R305	1-216-839-11	METAL CHIP	33K	5%	1/16W
R228	1-216-805-11	METAL CHIP	47	5%	1/16W	R306	1-216-833-11	METAL CHIP	10K	5%	1/16W
R230	1-216-809-11	METAL CHIP	100	5%	1/16W	R307	1-216-853-11	METAL CHIP	470K	5%	1/16W
R231	1-216-809-11	METAL CHIP	100	5%	1/16W	R308	1-216-845-11	METAL CHIP	100K	5%	1/16W
R232	1-216-845-11	METAL CHIP	100K	5%	1/16W	R309	1-216-833-11	METAL CHIP	10K	5%	1/16W
R235	1-216-864-11	METAL CHIP	0	5%	1/16W	R313	1-216-833-11	METAL CHIP	10K	5%	1/16W
R236	1-216-809-11	METAL CHIP	100	5%	1/16W	R314	1-216-821-11	METAL CHIP	1K	5%	1/16W
R237	1-216-809-11	METAL CHIP	100	5%	1/16W	R315	1-216-837-11	METAL CHIP	22K	5%	1/16W
R238	1-216-809-11	METAL CHIP	100	5%	1/16W	R316	1-216-818-11	METAL CHIP	560	5%	1/16W
R239	1-216-809-11	METAL CHIP	100	5%	1/16W	R317	1-216-843-11	METAL CHIP	68K	5%	1/16W
R240	1-216-805-11	METAL CHIP	47	5%	1/16W	R318	1-216-817-11	METAL CHIP	470	5%	1/16W
R241	1-216-805-11	METAL CHIP	47	5%	1/16W	R319	1-216-851-11	METAL CHIP	330K	5%	1/16W
R242	1-216-864-11	METAL CHIP	0	5%	1/16W	R320	1-216-817-11	METAL CHIP	470	5%	1/16W
R243	1-216-801-11	METAL CHIP	22	5%	1/16W	R321	1-216-849-11	METAL CHIP	220K	5%	1/16W
R244	1-216-809-11	METAL CHIP	100	5%	1/16W	R322	1-218-851-11	RES,CHIP	1.5K	0.50%	1/16W
R245	1-216-864-11	METAL CHIP	0	5%	1/16W	R324	1-216-817-11	METAL CHIP	470	5%	1/16W
R246	1-216-864-11	METAL CHIP	0	5%	1/16W	R325	1-216-821-11	METAL CHIP	1K	5%	1/16W
R247	1-216-864-11	METAL CHIP	0	5%	1/16W	R326	1-216-821-11	METAL CHIP	1K	5%	1/16W
R248	1-216-864-11	METAL CHIP	0	5%	1/16W	R327	1-216-821-11	METAL CHIP	1K	5%	1/16W
R249	1-216-864-11	METAL CHIP	0	5%	1/16W	R328	1-216-821-11	METAL CHIP	1K	5%	1/16W
R250	1-216-809-11	METAL CHIP	100	5%	1/16W	R329	1-216-855-11	METAL CHIP	680K	5%	1/16W
R251	1-216-809-11	METAL CHIP	100	5%	1/16W	R331	1-216-821-11	METAL CHIP	1K	5%	1/16W
R252	1-216-821-11	METAL CHIP	1K	5%	1/16W	R332	1-218-871-11	RES,CHIP	10K	0.50%	1/16W
R253	1-216-801-11	METAL CHIP	22	5%	1/16W	R333	1-216-864-11	METAL CHIP	0	5%	1/16W
R254	1-216-805-11	METAL CHIP	47	5%	1/16W	R334	1-216-821-11	METAL CHIP	1K	5%	1/16W
R255	1-216-805-11	METAL CHIP	47	5%	1/16W	R335	1-216-849-11	METAL CHIP	220K	5%	1/16W
R256	1-216-805-11	METAL CHIP	47	5%	1/16W	R336	1-216-849-11	METAL CHIP	220K	5%	1/16W
R257	1-216-805-11	METAL CHIP	47	5%	1/16W	R338	1-216-845-11	METAL CHIP	100K	5%	1/16W
R258	1-216-805-11	METAL CHIP	47	5%	1/16W	R339	1-218-859-11	RES,CHIP	3.3K	0.50%	1/16W
R259	1-216-805-11	METAL CHIP	47	5%	1/16W	R340	1-218-855-11	RES,CHIP	2.2K	0.50%	1/16W
R260	1-216-805-11	METAL CHIP	47	5%	1/16W	R341	1-216-789-11	METAL CHIP	2.2	5%	1/16W
R261	1-216-805-11	METAL CHIP	47	5%	1/16W	R342	1-216-789-11	METAL CHIP	2.2	5%	1/16W

**MB-84**

Ref. No.	Part No.	Description			Remark	Ref. No.	Part No.	Description			Remark
R343	1-216-789-11	METAL CHIP	2.2	5%	1/16W	R416	1-216-837-11	METAL CHIP	22K	5%	1/16W
R344	1-216-789-11	METAL CHIP	2.2	5%	1/16W	R417	1-216-833-11	METAL CHIP	10K	5%	1/16W
R345	1-216-797-11	METAL CHIP	10	5%	1/16W	R418	1-216-833-11	METAL CHIP	10K	5%	1/16W
R346	1-216-798-11	RES,CHIP	12	5%	1/16W	R419	1-216-838-11	METAL CHIP	27K	5%	1/16W
R347	1-218-859-11	RES,CHIP	3.3K	0.50%	1/16W	R420	1-216-829-11	METAL CHIP	4.7K	5%	1/16W
R348	1-218-863-11	RES,CHIP	4.7K	0.50%	1/16W	R421	1-216-836-11	METAL CHIP	18K	5%	1/16W
R349	1-218-859-11	RES,CHIP	3.3K	0.50%	1/16W	R422	1-216-836-11	METAL CHIP	18K	5%	1/16W
R350	1-218-863-11	RES,CHIP	4.7K	0.50%	1/16W	R423	1-216-833-11	METAL CHIP	10K	5%	1/16W
R351	1-216-797-11	METAL CHIP	10	5%	1/16W	R424	1-216-841-11	METAL CHIP	47K	5%	1/16W
R352	1-216-798-11	RES,CHIP	12	5%	1/16W	R425	1-216-825-11	METAL CHIP	2.2K	5%	1/16W
R353	1-216-798-11	RES,CHIP	12	5%	1/16W	R426	1-216-825-11	METAL CHIP	2.2K	5%	1/16W
R354	1-216-821-11	METAL CHIP	1K	5%	1/16W	R427	1-216-825-11	METAL CHIP	2.2K	5%	1/16W
R355	1-216-823-11	METAL CHIP	1.5K	5%	1/16W	R428	1-216-825-11	METAL CHIP	2.2K	5%	1/16W
R356	1-216-833-11	METAL CHIP	10K	5%	1/16W	R459	1-216-864-11	METAL CHIP	0	5%	1/16W
R357	1-216-837-11	METAL CHIP	22K	5%	1/16W	R460	1-216-809-11	METAL CHIP	100	5%	1/16W
R360	1-216-817-11	METAL CHIP	470	5%	1/16W	R486	1-216-821-11	METAL CHIP	1K	5%	1/16W
R361	1-216-864-11	METAL CHIP	0	5%	1/16W	R487	1-216-821-11	METAL CHIP	1K	5%	1/16W
R362	1-216-833-11	METAL CHIP	10K	5%	1/16W	R488	1-216-857-11	METAL CHIP	1M	5%	1/16W
R363	1-216-833-11	METAL CHIP	10K	5%	1/16W	R489	1-216-819-11	METAL CHIP	680	5%	1/16W
R365	1-216-841-11	METAL CHIP	47K	5%	1/16W	R490	1-216-839-11	METAL CHIP	33K	5%	1/16W
R366	1-216-833-11	METAL CHIP	10K	5%	1/16W	R491	1-216-833-11	METAL CHIP	10K	5%	1/16W
R367	1-216-841-11	METAL CHIP	47K	5%	1/16W	R492	1-216-839-11	METAL CHIP	33K	5%	1/16W
R368	1-216-837-11	METAL CHIP	22K	5%	1/16W	R493	1-216-833-11	METAL CHIP	10K	5%	1/16W
R369	1-216-833-11	METAL CHIP	10K	5%	1/16W	R494	1-216-819-11	METAL CHIP	680	5%	1/16W
R371	1-216-864-11	METAL CHIP	0	5%	1/16W	R495	1-216-857-11	METAL CHIP	1M	5%	1/16W
R372	1-216-864-11	METAL CHIP	0	5%	1/16W	R501	1-216-831-11	METAL CHIP	6.8K	5%	1/16W
R373	1-216-821-11	METAL CHIP	1K	5%	1/16W	R503	1-216-825-11	METAL CHIP	2.2K	5%	1/16W
R374	1-216-829-11	METAL CHIP	4.7K	5%	1/16W	R508	1-216-829-11	METAL CHIP	4.7K	5%	1/16W
R375	1-216-797-11	METAL CHIP	10	5%	1/16W	R509	1-216-833-11	METAL CHIP	10K	5%	1/16W
R376	1-216-797-11	METAL CHIP	10	5%	1/16W	R510	1-216-821-11	METAL CHIP	1K	5%	1/16W
R377	1-216-797-11	METAL CHIP	10	5%	1/16W	R511	1-216-833-11	METAL CHIP	10K	5%	1/16W
R378	1-216-797-11	METAL CHIP	10	5%	1/16W	R512	1-216-833-11	METAL CHIP	10K	5%	1/16W
R381	1-216-833-11	METAL CHIP	10K	5%	1/16W	R514	1-216-864-11	METAL CHIP	0	5%	1/16W
R385	1-216-864-11	METAL CHIP	0	5%	1/16W	R515	1-216-809-11	METAL CHIP	100	5%	1/16W
R386	1-216-864-11	METAL CHIP	0	5%	1/16W	R516	1-216-837-11	METAL CHIP	22K	5%	1/16W
R387	1-216-864-11	METAL CHIP	0	5%	1/16W	R517	1-216-825-11	METAL CHIP	2.2K	5%	1/16W
R388	1-216-864-11	METAL CHIP	0	5%	1/16W	R518	1-216-864-11	METAL CHIP	0	5%	1/16W
R393	1-216-797-11	METAL CHIP	10	5%	1/16W	R519	1-216-825-11	METAL CHIP	2.2K	5%	1/16W
R394	1-216-797-11	METAL CHIP	10	5%	1/16W	R520	1-216-825-11	METAL CHIP	2.2K	5%	1/16W
R395	1-216-797-11	METAL CHIP	10	5%	1/16W	R521	1-216-821-11	METAL CHIP	1K	5%	1/16W
R396	1-216-797-11	METAL CHIP	10	5%	1/16W	R522	1-216-821-11	METAL CHIP	1K	5%	1/16W
R397	1-216-837-11	METAL CHIP	22K	5%	1/16W	R523	1-216-846-11	METAL CHIP	120K	5%	1/16W
R398	1-216-837-11	METAL CHIP	22K	5%	1/16W	R524	1-216-833-11	METAL CHIP	10K	5%	1/16W
R399	1-216-797-11	METAL CHIP	10	5%	1/16W	R525	1-216-809-11	METAL CHIP	100	5%	1/16W
R400	1-216-797-11	METAL CHIP	10	5%	1/16W	R526	1-216-825-11	METAL CHIP	2.2K	5%	1/16W
R401	1-216-797-11	METAL CHIP	10	5%	1/16W	R527	1-216-864-11	METAL CHIP	0	5%	1/16W
R402	1-216-797-11	METAL CHIP	10	5%	1/16W	R528	1-216-825-11	METAL CHIP	2.2K	5%	1/16W
R403	1-218-446-11	METAL CHIP	1	5%	1/16W	R529	1-216-835-11	METAL CHIP	15K	5%	1/16W
R404	1-218-446-11	METAL CHIP	1	5%	1/16W	R530	1-216-837-11	METAL CHIP	22K	5%	1/16W
R405	1-218-446-11	METAL CHIP	1	5%	1/16W	R531	1-216-833-11	METAL CHIP	10K	5%	1/16W
R406	1-218-446-11	METAL CHIP	1	5%	1/16W	R532	1-216-833-11	METAL CHIP	10K	5%	1/16W
R407	1-216-134-00	METAL CHIP	2.2	5%	1/8W	R533	1-216-845-11	METAL CHIP	100K	5%	1/16W
R408	1-216-134-00	METAL CHIP	2.2	5%	1/8W	R534	1-216-833-11	METAL CHIP	10K	5%	1/16W
R409	1-216-134-00	METAL CHIP	2.2	5%	1/8W	R535	1-216-829-11	METAL CHIP	4.7K	5%	1/16W
R410	1-216-134-00	METAL CHIP	2.2	5%	1/8W	R536	1-216-845-11	METAL CHIP	100K	5%	1/16W
R411	1-216-835-11	METAL CHIP	15K	5%	1/16W	R537	1-216-845-11	METAL CHIP	100K	5%	1/16W
R412	1-216-835-11	METAL CHIP	15K	5%	1/16W	R538	1-216-809-11	METAL CHIP	100	5%	1/16W
R413	1-216-844-11	METAL CHIP	82K	5%	1/16W	R539	1-216-864-11	METAL CHIP	0	5%	1/16W
R414	1-216-844-11	METAL CHIP	82K	5%	1/16W	R540	1-216-864-11	METAL CHIP	0	5%	1/16W
R415	1-216-837-11	METAL CHIP	22K	5%	1/16W	R541	1-216-845-11	METAL CHIP	100K	5%	1/16W

Ref. No.	Part No.	Description			Remark	Ref. No.	Part No.	Description			Remark
R542	1-216-841-11	METAL CHIP	47K	5%	1/16W	R618	1-218-871-11	RES,CHIP	10K	0.50%	1/16W
R543	1-216-821-11	METAL CHIP	1K	5%	1/16W	R619	1-218-871-11	RES,CHIP	10K	0.50%	1/16W
R545	1-218-847-11	RES,CHIP	1K	0.50%	1/16W	R620	1-218-871-11	RES,CHIP	10K	0.50%	1/16W
R546	1-216-797-11	METAL CHIP	10	5%	1/16W	R622	1-216-864-11	METAL CHIP	0	5%	1/16W
R547	1-216-797-11	METAL CHIP	10	5%	1/16W	R626	1-218-871-11	RES,CHIP	10K	0.50%	1/16W
R548	1-216-864-11	METAL CHIP	0	5%	1/16W	R628	1-216-864-11	METAL CHIP	0	5%	1/16W
R550	1-216-809-11	METAL CHIP	100	5%	1/16W	R630	1-216-821-11	METAL CHIP	1K	5%	1/16W
R551	1-218-847-11	RES,CHIP	1K	0.50%	1/16W	R631	1-216-821-11	METAL CHIP	1K	5%	1/16W
R552	1-216-809-11	METAL CHIP	100	5%	1/16W	R632	1-216-833-11	METAL CHIP	10K	5%	1/16W
R553	1-216-809-11	METAL CHIP	100	5%	1/16W	R633	1-216-809-11	METAL CHIP	100	5%	1/16W
R554	1-216-809-11	METAL CHIP	100	5%	1/16W	R634	1-216-833-11	METAL CHIP	10K	5%	1/16W
R555	1-216-809-11	METAL CHIP	100	5%	1/16W	R635	1-216-809-11	METAL CHIP	100	5%	1/16W
R556	1-216-829-11	METAL CHIP	4.7K	5%	1/16W	R636	1-216-864-11	METAL CHIP	0	5%	1/16W
R557	1-216-809-11	METAL CHIP	100	5%	1/16W	R637	1-216-833-11	METAL CHIP	10K	5%	1/16W
R558	1-216-829-11	METAL CHIP	4.7K	5%	1/16W	R638	1-216-833-11	METAL CHIP	10K	5%	1/16W
R559	1-216-809-11	METAL CHIP	100	5%	1/16W	R640	1-216-833-11	METAL CHIP	10K	5%	1/16W
R560	1-218-847-11	RES,CHIP	1K	0.50%	1/16W	R641	1-216-833-11	METAL CHIP	10K	5%	1/16W
R561	1-216-837-11	METAL CHIP	22K	5%	1/16W	R643	1-216-833-11	METAL CHIP	10K	5%	1/16W
R562	1-216-864-11	METAL CHIP	0	5%	1/16W	R644	1-216-833-11	METAL CHIP	10K	5%	1/16W
R563	1-216-833-11	METAL CHIP	10K	5%	1/16W	R645	1-216-833-11	METAL CHIP	10K	5%	1/16W
R564	1-216-827-11	METAL CHIP	3.3K	5%	1/16W	R647	1-216-833-11	METAL CHIP	10K	5%	1/16W
R565	1-216-833-11	METAL CHIP	10K	5%	1/16W	R648	1-216-833-11	METAL CHIP	10K	5%	1/16W
R567	1-216-809-11	METAL CHIP	100	5%	1/16W	R649	1-216-864-11	METAL CHIP	0	5%	1/16W
R568	1-216-809-11	METAL CHIP	100	5%	1/16W	R650	1-216-833-11	METAL CHIP	10K	5%	1/16W
R569	1-216-809-11	METAL CHIP	100	5%	1/16W	R652	1-216-833-11	METAL CHIP	10K	5%	1/16W
R570	1-216-809-11	METAL CHIP	100	5%	1/16W	R653	1-216-833-11	METAL CHIP	10K	5%	1/16W
R571	1-216-809-11	METAL CHIP	100	5%	1/16W	R654	1-216-833-11	METAL CHIP	10K	5%	1/16W
R572	1-216-809-11	METAL CHIP	100	5%	1/16W	R658	1-216-833-11	METAL CHIP	10K	5%	1/16W
R573	1-216-809-11	METAL CHIP	100	5%	1/16W	R660	1-216-833-11	METAL CHIP	10K	5%	1/16W
R574	1-216-809-11	METAL CHIP	100	5%	1/16W	R663	1-216-833-11	METAL CHIP	10K	5%	1/16W
R575	1-218-457-11	RES,CHIP	910	5%	1/16W	R665	1-216-833-11	METAL CHIP	10K	5%	1/16W
R578	1-218-847-11	RES,CHIP	1K	0.50%	1/16W	R666	1-216-851-11	METAL CHIP	330K	5%	1/16W
R579	1-216-835-11	METAL CHIP	15K	5%	1/16W	R667	1-216-864-11	METAL CHIP	0	5%	1/16W
R580	1-216-809-11	METAL CHIP	100	5%	1/16W	R668	1-216-833-11	METAL CHIP	10K	5%	1/16W
R582	1-216-864-11	METAL CHIP	0	5%	1/16W	R669	1-216-839-11	METAL CHIP	33K	5%	1/16W
R583	1-216-809-11	METAL CHIP	100	5%	1/16W	R670	1-216-825-11	METAL CHIP	2.2K	5%	1/16W
R584	1-216-809-11	METAL CHIP	100	5%	1/16W	R672	1-216-833-11	METAL CHIP	10K	5%	1/16W
R585	1-216-821-11	METAL CHIP	1K	5%	1/16W	R674	1-216-809-11	METAL CHIP	100	5%	1/16W
R586	1-216-833-11	METAL CHIP	10K	5%	1/16W	R675	1-216-837-11	METAL CHIP	22K	5%	1/16W
R587	1-216-809-11	METAL CHIP	100	5%	1/16W	R676	1-216-809-11	METAL CHIP	100	5%	1/16W
R588	1-216-809-11	METAL CHIP	100	5%	1/16W	R679	1-216-809-11	METAL CHIP	100	5%	1/16W
R590	1-216-809-11	METAL CHIP	100	5%	1/16W	R680	1-216-809-11	METAL CHIP	100	5%	1/16W
R592	1-216-845-11	METAL CHIP	100K	5%	1/16W	R681	1-216-809-11	METAL CHIP	100	5%	1/16W
R593	1-216-837-11	METAL CHIP	22K	5%	1/16W	R682	1-216-848-11	METAL CHIP	180K	5%	1/16W
R594	1-216-857-11	METAL CHIP	1M	5%	1/16W	R683	1-216-864-11	METAL CHIP	0	5%	1/16W
R595	1-216-833-11	METAL CHIP	10K	5%	1/16W	R688	1-216-837-11	METAL CHIP	22K	5%	1/16W
R596	1-216-839-11	METAL CHIP	33K	5%	1/16W	R689	1-216-801-11	METAL CHIP	22	5%	1/16W
R597	1-216-827-11	METAL CHIP	3.3K	5%	1/16W	R690	1-216-801-11	METAL CHIP	22	5%	1/16W
R598	1-216-825-11	METAL CHIP	2.2K	5%	1/16W	R691	1-216-801-11	METAL CHIP	22	5%	1/16W
R601	1-216-833-11	METAL CHIP	10K	5%	1/16W	R693	1-216-821-11	METAL CHIP	1K	5%	1/16W
R602	1-216-833-11	METAL CHIP	10K	5%	1/16W	R694	1-216-833-11	METAL CHIP	10K	5%	1/16W
R605	1-216-845-11	METAL CHIP	100K	5%	1/16W	R696	1-216-841-11	METAL CHIP	47K	5%	1/16W
R607	1-216-833-11	METAL CHIP	10K	5%	1/16W	R698	1-216-864-11	METAL CHIP	0	5%	1/16W
R610	1-216-833-11	METAL CHIP	10K	5%	1/16W	R699	1-218-895-11	RES,CHIP	100K	0.50%	1/16W
R612	1-216-864-11	METAL CHIP	0	5%	1/16W	R797	1-216-864-11	METAL CHIP	0	5%	1/16W
R613	1-216-833-11	METAL CHIP	10K	5%	1/16W	R798	1-216-864-11	METAL CHIP	0	5%	1/16W
R614	1-216-833-11	METAL CHIP	10K	5%	1/16W	R801	1-216-809-11	METAL CHIP	100	5%	1/16W
R615	1-216-833-11	METAL CHIP	10K	5%	1/16W	R802	1-216-833-11	METAL CHIP	10K	5%	1/16W
R616	1-218-871-11	RES,CHIP	10K	0.50%	1/16W	R803	1-216-833-11	METAL CHIP	10K	5%	1/16W
R617	1-218-871-11	RES,CHIP	10K	0.50%	1/16W	R804	1-216-833-11	METAL CHIP	10K	5%	1/16W



Ref. No.	Part No.	Description	Remark
R805	1-216-833-11	METAL CHIP 10K	5% 1/16W
R806	1-216-833-11	METAL CHIP 10K	5% 1/16W
R808	1-216-833-11	METAL CHIP 10K	5% 1/16W
R809	1-216-833-11	METAL CHIP 10K	5% 1/16W
R811	1-216-833-11	METAL CHIP 10K	5% 1/16W
R812	1-216-833-11	METAL CHIP 10K	5% 1/16W
R813	1-216-833-11	METAL CHIP 10K	5% 1/16W
R815	1-216-864-11	METAL CHIP 0	5% 1/16W
R816	1-216-833-11	METAL CHIP 10K	5% 1/16W
R817	1-216-833-11	METAL CHIP 10K	5% 1/16W
R818	1-216-833-11	METAL CHIP 10K	5% 1/16W
R819	1-216-833-11	METAL CHIP 10K	5% 1/16W
R820	1-216-833-11	METAL CHIP 10K	5% 1/16W
R821	1-216-833-11	METAL CHIP 10K	5% 1/16W
R822	1-216-797-11	METAL CHIP 10	5% 1/16W
R824	1-216-797-11	METAL CHIP 10	5% 1/16W
R825	1-216-809-11	METAL CHIP 100	5% 1/16W
R826	1-216-797-11	METAL CHIP 10	5% 1/16W
R827	1-216-797-11	METAL CHIP 10	5% 1/16W
R828	1-216-805-11	METAL CHIP 47	5% 1/16W
R829	1-216-864-11	METAL CHIP 0	5% 1/16W
R830	1-216-864-11	METAL CHIP 0	5% 1/16W
R831	1-216-864-11	METAL CHIP 0	5% 1/16W
R832	1-216-805-11	METAL CHIP 47	5% 1/16W
R834	1-216-809-11	METAL CHIP 100	5% 1/16W
R835	1-216-809-11	METAL CHIP 100	5% 1/16W
R836	1-216-809-11	METAL CHIP 100	5% 1/16W
R837	1-216-809-11	METAL CHIP 100	5% 1/16W
R838	1-216-833-11	METAL CHIP 10K	5% 1/16W
R839	1-216-857-11	METAL CHIP 1M	5% 1/16W
R840	1-216-864-11	METAL CHIP 0	5% 1/16W
R842	1-216-801-11	METAL CHIP 22	5% 1/16W
R843	1-218-881-11	RES,CHIP 27K	0.50% 1/16W
R844	1-218-847-11	RES,CHIP 1K	0.50% 1/16W
R845	1-218-885-11	RES,CHIP 39K	0.50% 1/16W
R847	1-216-833-11	METAL CHIP 10K	5% 1/16W
R848	1-216-864-11	METAL CHIP 0	5% 1/16W
R849	1-218-831-11	RES,CHIP 220	0.50% 1/16W
R850	1-218-853-11	RES,CHIP 1.8K	0.50% 1/16W
R851	1-218-855-11	RES,CHIP 2.2K	0.50% 1/16W
R852	1-218-871-11	RES,CHIP 10K	0.50% 1/16W
R853	1-218-871-11	RES,CHIP 10K	0.50% 1/16W
R854	1-216-809-11	METAL CHIP 100	5% 1/16W
R855	1-216-833-11	METAL CHIP 10K	5% 1/16W
R856	1-216-837-11	METAL CHIP 22K	5% 1/16W
R857	1-216-825-11	METAL CHIP 2.2K	5% 1/16W
R858	1-216-838-11	METAL CHIP 27K	5% 1/16W
R859	1-216-825-11	METAL CHIP 2.2K	5% 1/16W
R860	1-216-821-11	METAL CHIP 1K	5% 1/16W
R861	1-216-833-11	METAL CHIP 10K	5% 1/16W
R862	1-216-833-11	METAL CHIP 10K	5% 1/16W
R863	1-216-809-11	METAL CHIP 100	5% 1/16W
R864	1-216-809-11	METAL CHIP 100	5% 1/16W
R865	1-216-809-11	METAL CHIP 100	5% 1/16W
R868	1-216-864-11	METAL CHIP 0	5% 1/16W
R869	1-216-864-11	METAL CHIP 0	5% 1/16W
R870	1-216-864-11	METAL CHIP 0	5% 1/16W
R871	1-216-833-11	METAL CHIP 10K	5% 1/16W
R872	1-216-809-11	METAL CHIP 100	5% 1/16W
R873	1-216-809-11	METAL CHIP 100	5% 1/16W

Ref. No.	Part No.	Description	Remark
R874	1-216-809-11	METAL CHIP 100	5% 1/16W
R875	1-216-809-11	METAL CHIP 100	5% 1/16W
R876	1-216-809-11	METAL CHIP 100	5% 1/16W
R877	1-216-809-11	METAL CHIP 100	5% 1/16W
R878	1-216-833-11	METAL CHIP 10K	5% 1/16W
R880	1-216-864-11	METAL CHIP 0	5% 1/16W
R882	1-216-864-11	METAL CHIP 0	5% 1/16W
R883	1-216-864-11	METAL CHIP 0	5% 1/16W
R884	1-216-833-11	METAL CHIP 10K	5% 1/16W
R885	1-216-864-11	METAL CHIP 0	5% 1/16W
R889	1-216-833-11	METAL CHIP 10K	5% 1/16W
R890	1-216-833-11	METAL CHIP 10K	5% 1/16W
R891	1-216-833-11	METAL CHIP 10K	5% 1/16W
R892	1-216-833-11	METAL CHIP 10K	5% 1/16W
R897	1-216-864-11	METAL CHIP 0	5% 1/16W
R898	1-216-864-11	METAL CHIP 0	5% 1/16W
R899	1-216-864-11	METAL CHIP 0	5% 1/16W
R900	1-216-864-11	METAL CHIP 0	5% 1/16W
R905	1-216-841-11	METAL CHIP 47K	5% 1/16W
R907	1-216-864-11	METAL CHIP 0	5% 1/16W
R908	1-216-833-11	METAL CHIP 10K	5% 1/16W
R911	1-216-809-11	METAL CHIP 100	5% 1/16W
R912	1-216-825-11	METAL CHIP 2.2K	5% 1/16W
R914	1-216-833-11	METAL CHIP 10K	5% 1/16W
R917	1-216-833-11	METAL CHIP 10K	5% 1/16W
R919	1-216-809-11	METAL CHIP 100	5% 1/16W
R920	1-216-809-11	METAL CHIP 100	5% 1/16W
R921	1-216-809-11	METAL CHIP 100	5% 1/16W
R922	1-216-817-11	METAL CHIP 470	5% 1/16W
R923	1-216-833-11	METAL CHIP 10K	5% 1/16W
R924	1-218-289-11	RES,CHIP 510	5% 1/16W
R926	1-216-864-11	METAL CHIP 0	5% 1/16W
R927	1-216-864-11	METAL CHIP 0	5% 1/16W
R929	1-216-864-11	METAL CHIP 0	5% 1/16W
R930	1-216-864-11	METAL CHIP 0	5% 1/16W
R932	1-216-809-11	METAL CHIP 100	5% 1/16W
R933	1-216-833-11	METAL CHIP 10K	5% 1/16W
< VARIABLE RESISTOR >			
RV251	1-238-663-11	RES, ADJ, CARBON 4.7K (VIDEO LEVEL ADJ)	
< VIBRATOR >			
X201	1-767-990-11	VIBRATOR, CRYSTAL (27MHz)	
X601	1-767-359-11	VIBRATOR, CERAMIC (4MHz)	
X801	1-767-861-21	VIBRATOR, CRYSTAL (20MHz)	
*****			
*	1-468-287-12	POWER BLOCK (HS-930SU)	(Ref.No.4,000 Series)
< CAPACITOR >			
C110	9-880-434-01	ELECT 270uF	250V
C114	1-107-967-11	ELECT 1uF	400V
C211	1-111-087-11	ELECT 330uF	35V
C212	1-126-947-11	ELECT 47uF	35V
C213	1-126-947-11	ELECT 47uF	35V
C214	1-126-947-11	ELECT 47uF	35V
C301	1-126-960-11	ELECT 1uF	50V
C311	1-111-087-11	ELECT 330uF	35V

Ref. No.	Part No.	Description	Remark	Ref. No.	Part No.	Description	Remark
C313	1-126-947-11	ELECT	47uF	35V	*	A-6065-173-A	PS-420 BOARD, COMPLETE
C314	1-126-948-11	ELECT	100uF	35V			*****
C315	1-126-954-11	ELECT	10uF	50V			(Ref.No.1,000 Series)
C411	1-126-947-11	ELECT	47uF	35V			
C511	1-126-942-11	ELECT	1000uF	25V			< CAPACITOR >
C512	1-126-947-11	ELECT	47uF	35V	△C901	1-104-705-11	FILM 0.1uF 20% 250V
C513	1-126-947-11	ELECT	47uF	35V	C902	1-126-962-11	ELECT 3.3uF 20% 50V
C611	1-111-090-11	ELECT	560uF	35V	C903	1-130-487-00	MYLAR 0.022uF 5% 50V
C612	1-126-947-11	ELECT	47uF	35V	C904	1-127-744-51	ELECT 470uF 20% 50V
					C905	1-127-744-51	ELECT 470uF 20% 50V
		< DIODE >			C908	1-126-964-11	ELECT 10uF 20% 50V
D101	8-719-064-12	DIODE	S1NB60		C909	1-136-850-11	FILM 0.1uF 5% 63V
D104	8-719-109-57	DIODE	RD2.4ESB2		C910	1-136-850-11	FILM 0.1uF 5% 63V
D105	9-980-073-01	DIODE	1CC270A		C911	1-136-850-11	FILM 0.1uF 5% 63V
D106	9-880-435-01	DIODE	D1N60		C912	1-128-551-11	ELECT 22uF 20% 25V
D109	9-880-435-01	DIODE	D1N60		C913	1-136-850-11	FILM 0.1uF 5% 63V
D211	8-719-510-17	DIODE	S2L20A				< CONNECTOR >
D212	8-719-100-90	DIODE	RD24EB2		* CN901	1-580-230-11	PIN, CONNECTOR (PC BOARD) 2P
D311	8-719-500-50	DIODE	D3S4M		* CN902	1-564-321-21	PIN, CONNECTOR 2P
D312	9-980-073-01	DIODE	1CC270A		CN903	1-564-321-00	PIN, CONNECTOR 2P
D313	8-719-109-60	DIODE	RD2.7ESB2		* CN904	1-564-241-11	PIN, CONNECTOR (B4P-VH) 4P
D511	8-719-510-17	DIODE	S2L20A		* CN905	1-564-510-11	PLUG, CONNECTOR 7P
D611	8-719-500-50	DIODE	D3S4M				< DIODE >
		< FUSE >			D901	8-719-210-21	DIODE 11EQS04
△F101	1-533-296-11	FUSE	(2A/125V)		D902	8-719-210-21	DIODE 11EQS04
		< IC >			D903	8-719-914-43	DIODE DAN202K-T-146
IC301	8-759-420-19	IC	AN1431T		D904	8-719-210-21	DIODE 11EQS04
IC611	9-880-436-01	IC	PQ3RD13		D905	8-719-210-21	DIODE 11EQS04
		< PROTECTOR >			D906	8-719-404-49	DIODE MA111
△P211	1-533-589-11	PROTECTOR	(750mA/125V)				< EARTH TERMINAL >
△P311	1-533-593-11	PROTECTOR	(2A/125V)		* ET901	1-537-738-21	TERMINAL, EARTH
△P312	1-533-589-11	PROTECTOR	(750mA/125V)				< FUSE >
△P511	1-533-589-11	PROTECTOR	(750mA/125V)		△F901	1-532-452-99	FUSE, GLASS CYLINDRICAL (DIA.5) (1A/125V)
		< PHOTO COUPLER >					< FUSE HOLDER >
△PC101	8-749-010-59	PHOTO COUPLER	TLP721F		FH901	1-533-223-11	HOLDER, FUSE
		< TRANSISTOR >			FH902	1-533-223-11	HOLDER, FUSE
Q101	9-880-437-01	TRANSISTOR	2SK2798				< LINE FILTER >
Q102	8-729-024-00	TRANSISTOR	2SC3377		* LF901	1-416-446-11	FILTER, LINE
Q103	9-880-437-01	TRANSISTOR	2SK2798				< TRANSISTOR >
Q211	9-880-439-01	TRANSISTOR	2SJ488		Q901	8-729-424-46	TRANSISTOR UN211E
Q311	8-729-921-42	TRANSISTOR	2SA1679		Q902	8-729-421-19	TRANSISTOR UN2213
Q312	8-729-920-69	TRANSISTOR	2SC1740				< RESISTOR >
Q511	9-880-440-01	TRANSISTOR	2SK2279		R901	1-216-093-00	METAL CHIP 68K 5% 1/10W
Q512	8-729-920-67	TRANSISTOR	2SA933S		R903	1-216-101-00	METAL CHIP 150K 5% 1/10W
		< RESISITOR >			R904	1-216-113-00	METAL CHIP 470K 5% 1/10W
R152	1-219-121-21	FUSIBLE	0.22	1/4W			

The components identified by mark △ or dotted line with mark △ are critical for safety. Replace only with part number specified.

Les composants identifiés par une marque △ sont critiques pour la sécurité. Ne les remplacer que par une pièce portant le numéro spécifié.

<b>PS-420</b>	<b>PW-119</b>	<b>TK-47</b>
---------------	---------------	--------------

Ref. No.	Part No.	Description	Remark
		< RELAY >	
△RY901	1-755-031-11	RELAY	
<hr/>			
*	A-6065-166-A	PW-119 BOARD, COMPLETE ***** (Ref.No.1,000 Series)	
		< CAPACITOR >	
C301	1-126-205-11	ELECT CHIP 47uF 20% 6.3V	
		< CONNECTOR >	
CN301	1-770-688-11	CONNECTOR, FFC/FPC 5P	
		< DIODE >	
D303	8-719-027-84	DIODE CL-155UR/G-DT (ON/STANDBY)	
		< IC >	
IC301	8-749-011-22	IC GP1U27X	
		< COIL >	
L301	1-414-936-21	INDUCTOR 22uH	
		< TRANSISTOR >	
Q301	8-729-424-08	TRANSISTOR UN2111	
		< RESISTOR >	
R301	1-216-295-91	SHORT 0	
R302	1-216-037-00	METAL CHIP 330 5% 1/10W	
R303	1-216-033-00	METAL CHIP 220 5% 1/10W	
		< SWITCH >	
S301	1-771-349-21	SWITCH, KEYBOARD (POWER)	
<hr/>			
*	A-6065-077-A	TK-47 BOARD, COMPLETE ***** (Ref.No.3,000 Sereis)	
		< CAPACITOR >	
C001	1-163-021-91	CERAMIC CHIP 0.01uF 10% 50V	
C003	1-163-038-91	CERAMIC CHIP 0.1uF 25V	
C004	1-163-038-91	CERAMIC CHIP 0.1uF 25V	
C005	1-163-038-91	CERAMIC CHIP 0.1uF 25V	
C006	1-126-205-11	ELECT CHIP 47uF 20% 6.3V	
C007	1-163-235-11	CERAMIC CHIP 22PF 5% 50V	
C008	1-163-235-11	CERAMIC CHIP 22PF 5% 50V	
C009	1-163-235-11	CERAMIC CHIP 22PF 5% 50V	
C010	1-163-235-11	CERAMIC CHIP 22PF 5% 50V	
C011	1-163-021-91	CERAMIC CHIP 0.01uF 10% 50V	
C028	1-124-779-00	ELECT CHIP 10uF 20% 16V	
C030	1-124-779-00	ELECT CHIP 10uF 20% 16V	
C031	1-164-161-11	CERAMIC CHIP 0.0022uF 10% 100V	
C032	1-124-779-00	ELECT CHIP 10uF 20% 16V	
C033	1-164-161-11	CERAMIC CHIP 0.0022uF 10% 100V	
C034	1-124-779-00	ELECT CHIP 10uF 20% 16V	

Ref. No.	Part No.	Description	Remark
C035	1-164-161-11	CERAMIC CHIP 0.0022uF 10% 100V	
C036	1-124-779-00	ELECT CHIP 10uF 20% 16V	
C037	1-163-009-11	CERAMIC CHIP 0.001uF 10% 50V	
C038	1-164-161-11	CERAMIC CHIP 0.0022uF 10% 100V	
C040	1-163-021-91	CERAMIC CHIP 0.01uF 10% 50V	
C042	1-163-989-11	CERAMIC CHIP 0.033uF 10% 25V	
C043	1-163-135-00	CERAMIC CHIP 560PF 5% 50V	
C046	1-163-018-00	CERAMIC CHIP 0.0056uF 5% 50V	
C047	1-163-018-00	CERAMIC CHIP 0.0056uF 5% 50V	
C050	1-107-725-11	CERAMIC CHIP 0.1uF 10% 16V	
C051	1-107-725-11	CERAMIC CHIP 0.1uF 10% 16V	
C052	1-163-021-91	CERAMIC CHIP 0.01uF 10% 50V	
C053	1-107-725-11	CERAMIC CHIP 0.1uF 10% 16V	
C054	1-107-725-11	CERAMIC CHIP 0.1uF 10% 16V	
C055	1-163-809-11	CERAMIC CHIP 0.047uF 10% 25V	
C056	1-107-725-11	CERAMIC CHIP 0.1uF 10% 16V	
C058	1-124-779-00	ELECT CHIP 10uF 20% 16V	
C059	1-163-009-11	CERAMIC CHIP 0.001uF 10% 50V	
C060	1-163-989-11	CERAMIC CHIP 0.033uF 10% 25V	
C061	1-163-989-11	CERAMIC CHIP 0.033uF 10% 25V	
C062	1-124-779-00	ELECT CHIP 10uF 20% 16V	
C064	1-124-779-00	ELECT CHIP 10uF 20% 16V	
C065	1-109-982-11	CERAMIC CHIP 1uF 10% 10V	
C066	1-163-021-91	CERAMIC CHIP 0.01uF 10% 50V	
C067	1-163-809-11	CERAMIC CHIP 0.047uF 10% 25V	
C068	1-163-121-00	CERAMIC CHIP 150PF 5% 50V	
C069	1-163-005-11	CERAMIC CHIP 470PF 10% 50V	
C070	1-163-021-91	CERAMIC CHIP 0.01uF 10% 50V	
C071	1-126-205-11	ELECT CHIP 47uF 20% 6.3V	
C072	1-163-038-91	CERAMIC CHIP 0.1uF 25V	
C073	1-126-205-11	ELECT CHIP 47uF 20% 6.3V	
C074	1-163-038-91	CERAMIC CHIP 0.1uF 25V	
C075	1-163-038-91	CERAMIC CHIP 0.1uF 25V	
C076	1-163-021-91	CERAMIC CHIP 0.01uF 10% 50V	
C077	1-126-205-11	ELECT CHIP 47uF 20% 6.3V	
C078	1-163-038-91	CERAMIC CHIP 0.1uF 25V	
C079	1-107-725-11	CERAMIC CHIP 0.1uF 10% 16V	
C082	1-163-021-91	CERAMIC CHIP 0.01uF 10% 50V	
C083	1-163-009-11	CERAMIC CHIP 0.001uF 10% 50V	
C084	1-163-021-91	CERAMIC CHIP 0.01uF 10% 50V	
C085	1-163-021-91	CERAMIC CHIP 0.01uF 10% 50V	
C096	1-163-038-91	CERAMIC CHIP 0.1uF 25V	
C097	1-163-038-91	CERAMIC CHIP 0.1uF 25V	
C098	1-163-021-91	CERAMIC CHIP 0.01uF 10% 50V	
C099	1-163-019-00	CERAMIC CHIP 0.0068uF 10% 50V	
C100	1-163-021-91	CERAMIC CHIP 0.01uF 10% 50V	
C101	1-163-021-91	CERAMIC CHIP 0.01uF 10% 50V	
C102	1-163-021-91	CERAMIC CHIP 0.01uF 10% 50V	
C103	1-163-021-91	CERAMIC CHIP 0.01uF 10% 50V	
C104	1-126-205-11	ELECT CHIP 47uF 20% 6.3V	
C105	1-163-021-91	CERAMIC CHIP 0.01uF 10% 50V	
C106	1-163-021-91	CERAMIC CHIP 0.01uF 10% 50V	
C107	1-126-205-11	ELECT CHIP 47uF 20% 6.3V	
		< CONNECTOR >	
CN001	1-779-342-21	CONNECTOR, FFC/FPC 42P	
* CN002	1-695-154-11	SOCKET, CONNECTOR 18P	
CN004	1-580-055-21	PIN, CONNECTOR 2P	

The components identified by mark △ or dotted line with mark △ are critical for safety. Replace only with part number specified.	Les composants identifiés par une marque △ sont critiques pour la sécurité. Ne les remplacer que par une pièce portant le numéro spécifié.
--	--

Ref. No.	Part No.	Description	Remark	Ref. No.	Part No.	Description	Remark
CN005	1-784-326-11	CONNECTOR, FFC/FPC 27P		R095	1-216-073-00	METAL CHIP 10K	5% 1/10W
CN008	1-784-326-11	CONNECTOR, FFC/FPC 27P		R100	1-216-049-91	RES,CHIP 1K	5% 1/10W
< DIODE >							
D003	8-719-421-27	DIODE MA728		R101	1-216-081-00	METAL CHIP 22K	5% 1/10W
D004	8-719-104-34	DIODE 1S2836		R102	1-216-081-00	METAL CHIP 22K	5% 1/10W
< IC >							
IC004	8-759-701-39	IC NJM3404AM		R103	1-216-049-91	RES,CHIP 1K	5% 1/10W
IC005	8-752-079-86	IC CXA2555Q-T4		R104	1-216-081-00	METAL CHIP 22K	5% 1/10W
IC006	8-759-487-01	IC SSI3P3720A-CGT		R105	1-216-109-00	METAL CHIP 330K	5% 1/10W
IC011	8-759-009-07	IC MC14053BFEL					
< COIL >							
L002	1-412-031-11	INDUCTOR CHIP 47uH		R111	1-216-073-00	METAL CHIP 10K	5% 1/10W
L003	1-412-031-11	INDUCTOR CHIP 47uH		R112	1-216-113-00	METAL CHIP 470K	5% 1/10W
L004	1-412-031-11	INDUCTOR CHIP 47uH		R113	1-216-057-00	METAL CHIP 2.2K	5% 1/10W
< PHOTO INTERRUPTER >							
PH001	8-749-011-97	PHOTO INTERUPTER GP1S93 (CHUCK SENSOR)		R149	1-216-073-00	METAL CHIP 10K	5% 1/10W
< TRANSISTOR >							
Q001	8-729-420-24	TRANSISTOR 2SB1218A-QRS		R150	1-216-081-00	METAL CHIP 22K	5% 1/10W
Q004	8-729-805-25	TRANSISTOR 2SB1121					
Q005	8-729-805-25	TRANSISTOR 2SB1121		R151	1-216-065-91	RES,CHIP 4.7K	5% 1/10W
Q007	8-729-805-25	TRANSISTOR 2SB1121		R152	1-216-077-00	METAL CHIP 15K	5% 1/10W
Q008	8-729-230-63	TRANSISTOR 2SC4116-YG		R153	1-216-093-00	METAL CHIP 68K	5% 1/10W
Q009	8-729-015-76	TRANSISTOR UN5211-TX		R154	1-216-081-00	METAL CHIP 22K	5% 1/10W
Q010	8-729-230-63	TRANSISTOR 2SC4116-YG		R155	1-216-081-00	METAL CHIP 22K	5% 1/10W
< RESISTOR >							
R001	1-216-025-91	RES,CHIP 100	5% 1/10W	R156	1-216-091-00	METAL CHIP 56K	5% 1/10W
R002	1-208-757-11	RES,CHIP 91	0.50% 1/10W	R157	1-216-091-00	METAL CHIP 56K	5% 1/10W
R003	1-216-037-00	METAL CHIP 330	5% 1/10W	R158	1-216-093-00	METAL CHIP 68K	5% 1/10W
R005	1-216-089-91	RES,CHIP 47K	5% 1/10W	R159	1-216-081-00	METAL CHIP 22K	5% 1/10W
R013	1-216-089-91	RES,CHIP 47K	5% 1/10W	R160	1-216-089-91	RES,CHIP 47K	5% 1/10W
				< SWITCH >			
R015	1-216-073-00	METAL CHIP 10K	5% 1/10W	S001	1-771-046-11	SWITCH, PUSH LEVER (TRAY SENSOR)	
R016	1-216-001-91	METAL CHIP 10	5% 1/10W				
R017	1-216-001-91	METAL CHIP 10	5% 1/10W				
R049	1-216-154-00	RES,CHIP 15	5% 1/8W				
R051	1-216-049-91	RES,CHIP 1K	5% 1/10W				
				< CAPACITOR >			
R052	1-216-001-00	METAL CHIP 10	5% 1/10W	C851	1-164-004-11	CERAMIC CHIP 0.1uF	10% 25V
R053	1-216-041-00	METAL CHIP 470	5% 1/10W	C852	1-128-551-11	ELECT 22uF	20% 25V
R064	1-216-047-91	RES,CHIP 820	5% 1/10W	C853	1-128-551-11	ELECT 22uF	20% 25V
R066	1-216-035-00	METAL CHIP 270	5% 1/10W	C854	1-104-665-11	ELECT 100uF	20% 10V
R068	1-216-295-91	SHORT 0		C855	1-104-664-11	ELECT 47uF	20% 16V
R070	1-216-097-91	RES,CHIP 100K	5% 1/10W	C856	1-104-665-11	ELECT 100uF	20% 10V
R072	1-216-097-91	RES,CHIP 100K	5% 1/10W	C857	1-104-665-11	ELECT 100uF	20% 10V
R073	1-216-075-00	METAL CHIP 12K	5% 1/10W	C858	1-126-925-11	ELECT 470uF	20% 10V
R075	1-216-109-00	METAL CHIP 330K	5% 1/10W	C865	1-163-227-91	CERAMIC CHIP 10PF	5% 50V
R077	1-216-001-00	METAL CHIP 10	5% 1/10W	C866	1-163-243-11	CERAMIC CHIP 47PF	5% 50V
R079	1-216-154-00	RES,CHIP 15	5% 1/8W	C867	1-163-243-11	CERAMIC CHIP 47PF	5% 50V
R084	1-216-121-91	RES,CHIP 1M	5% 1/10W	< CONNECTOR >			
R086	1-216-295-91	SHORT 0		CN851	1-784-683-11	CONNECTOR, FFC/FPC 9P	
R090	1-216-089-91	RES,CHIP 47K	5% 1/10W	< FERRITE BEAD >			
R091	1-216-073-00	METAL CHIP 10K	5% 1/10W	FB851	1-414-553-11	FERRITE 0UH	
R092	1-216-037-00	METAL CHIP 330	5% 1/10W	FB852	1-414-553-11	FERRITE 0UH	
R093	1-216-025-91	RES,CHIP 100	5% 1/10W				
R094	1-216-073-00	METAL CHIP 10K	5% 1/10W				

Ref. No.	Part No.	Description	Remark
FB853	1-414-553-11	FERRITE OUH	
		< IC >	
IC851	8-759-522-11	IC BA7660FS-E2	
		< JACK >	
J851	1-784-675-11	JACK, PIN 3P (COMPONENT VIDEO OUT)	
		< COIL >	
L851	1-414-930-21	INDUCTOR 2.2uH	
L852	1-412-951-11	INDUCTOR 10uH	
L853	1-412-951-11	INDUCTOR 10uH	
L854	1-412-959-21	INDUCTOR 1uH	
		< RESISTOR >	
R851	1-208-754-11	METAL CHIP 68 0.5% 1/10W	
R852	1-208-754-11	METAL CHIP 68 0.5% 1/10W	
R853	1-208-754-11	METAL CHIP 68 0.5% 1/10W	
R854	1-216-037-00	METAL CHIP 330 5% 1/10W	
R855	1-216-037-00	METAL CHIP 330 5% 1/10W	
R856	1-414-135-11	FERRITE 0uH	
<b>MISCELLANEOUS</b> *****			
59	1-790-144-11	CABLE, FLEXIBLE FLAT (FFP-11) (5P)	
62	1-475-109-11	SWITCH BLOCK, TOUCH	
64	1-671-924-11	FPL-1 FLEXIBLE BOARD	
67	1-790-143-11	CABLE, FLEXIBLE FLAT (FLR-2) (6P)	
68	1-790-140-11	CABLE, FLEXIBLE FLAT (FML-8) (20P)	
* 69	1-500-544-11	BEAD, FERRITE	
81	1-782-197-11	CABLE, FLEXIBLE FLAT (FFD-1) (6P)	
83	1-782-198-11	CABLE, FLEXIBLE FLAT (FDC-3) (3P)	
104	1-783-349-11	CABLE, FLEXIBLE FLAT (FMY-2) (9P)	
105	1-783-339-11	CABLE, FLEXIBLE FLAT (FMT-21) (27P)	
107	1-783-343-11	CABLE, FLEXIBLE FLAT (FMA-4) (25P)	
△ 110	1-790-154-11	CORD, POWER	
113	1-500-386-11	FILTER, CLAMP (FERRITE CORE)	
△ 207	8-820-005-02	OPTICAL PICK-UP KHS-180A/J1N	
208	1-665-390-11	OP-15 FLEXIBLE BOARD	
212	1-783-341-11	CABLE, FLEXIBLE FLAT (FMF-28) (8P)	
M501	X-3947-137-1	MOTOR ASSY, SLED	
M901	1-698-944-11	MOTOR, DC (SPINDLE)	
M902	1-698-942-21	MOTOR (LOADING)	
M903	X-3947-138-1	MOTOR ASSY, SKEW (TILT)	
△ T901	1-431-174-11	TRANSFORMER, POWER	

Ref. No.	Part No.	Description	Remark
		***** HARDWARE LIST *****	
#1	7-685-882-09	SCREW +BVTT 4X10 (S)	
#2	7-685-665-79	SCREW +BVTP 4X25 TYPE2 IT-3	
#3	7-685-647-79	SCREW +BVTP 3X10 TYPE2 IT-3	
#4	7-682-645-01	SCREW +PS 3X4	
#5	7-624-106-04	STOP RING 3.0, TYPE -E	
#7	7-627-852-08	SCREW, PRECISION +P 1.7X2.5	
#8	7-685-105-19	TPG +P 2X8, TYPE 2, NON-SLIT	
#9	7-627-852-18	SCREW, PRECISION +P 1.7X4 TYPE3	
<b>ACCESSORIES &amp; PACKING MATERIALS</b> *****			
1-418-075-21		COMMANDER, STANDARD (RMT-D107A/B)	
1-775-454-21		CORD, CONNECTION (STEREO AV S LINK CABLE 1.5m)	
1-776-078-31		CORD, CONNECTION (S-VIDEO CABLE 1.5m)	
1-782-149-11		CORD, CONNECTION (VIDEO CABLE 1.5m)	
1-782-150-11		CORD, CONNECTION (AUDIO (STEREO) CABLE 1.5m)	
3-864-941-11		MANUAL, INSTRUCTION (ENGLISH, FRENCH)	
3-709-044-01		LID, BATTERY CASE (for RMT-D107A/B)	

The components identified by mark △ or dotted line with mark △ are critical for safety. Replace only with part number specified.	Les composants identifiés par une marque △ sont critiques pour la sécurité. Ne les remplacer que par une pièce portant le numéro spécifié.
--	--

