

# AV RECEIVER RX-V1200/RX-V1200RDS/ HTR-5490/RX-V2200

## SERVICE MANUAL

RX-V1200/RX-V1200RDS/  
HTR-5490/RX-V2200

### IMPORTANT NOTICE

This manual has been provided for the use of authorized YAMAHA Retailers and their service personnel. It has been assumed that basic service procedures inherent to the industry, and more specifically YAMAHA Products, are already known and understood by the users, and have therefore not been restated.

**WARNING:** Failure to follow appropriate service and safety procedures when servicing this product may result in personal injury, destruction of expensive components, and failure of the product to perform as specified. For these reasons, we advise all YAMAHA product owners that any service required should be performed by an authorized YAMAHA Retailer or the appointed service representative.

**IMPORTANT:** The presentation or sale of this manual to any individual or firm does not constitute authorization, certification or recognition of any applicable technical capabilities, or establish a principle-agent relationship of any form.

The data provided is believed to be accurate and applicable to the unit(s) indicated on the cover. The research, engineering, and service departments of YAMAHA are continually striving to improve YAMAHA products. Modifications are, therefore, inevitable and specifications are subject to change without notice or obligation to retrofit. Should any discrepancy appear to exist, please contact the distributor's Service Division.

**WARNING:** Static discharges can destroy expensive components. Discharge any static electricity your body may have accumulated by grounding yourself to the ground buss in the unit (heavy gauge black wires connect to this buss).

**IMPORTANT:** Turn the unit OFF during disassembly and part replacement. Recheck all work before you apply power to the unit.

## ■ CONTENTS

TO SERVICE PERSONNEL .....	1	AMP ADJUSTMENT .....	36
IMPEDANCE SELECTOR .....	1	DISPLAY DATA .....	37~38
FRONT PANELS .....	2~3	IC DATA .....	39~45
REAR PANELS .....	3~7	BLOCK DIAGRAM .....	46~49
REMOTE CONTROL TRANSMITTER .....	8	PRINTED CIRCUIT BOARD .....	50~89
SPECIFICATIONS .....	9~10	PIN CONNECTION DIAGRAM .....	90~91
INTERNAL VIEW .....	11	SCHEMATIC DIAGRAM .....	92~99
DISASSEMBLY PROCEDURES .....	12~14	PARTS LIST .....	100~126
SELF DIAGNOSIS FUNCTION (DIAG) .....	15~36	REMOTE CONTROL TRANSMITTER .....	127~130



このサービスマニュアルは、エコマーク認定の再生紙を使用しています。  
This Service Manual uses recycled paper.



## ■ TO SERVICE PERSONNEL

### 1. Critical Components Information

Components having special characteristics are marked ⚠ and must be replaced with parts having specifications equal to those originally installed.

### 2. Leakage Current Measurement (For 120V Models Only)

When service has been completed, it is imperative to verify that all exposed conductive surfaces are properly insulated from supply circuits.

- Meter impedance should be equivalent to 1500 ohm shunted by 0.15μF.
- Leakage current must not exceed 0.5mA.
- Be sure to test for leakage with the AC plug in both polarities.



#### “CAUTION”

“F201, F202: FOR CONTINUED PROTECTION AGAINST RISK OF FIRE, REPLACE ONLY WITH SAME TYPE 8A, 125V FUSE.”

#### CAUTION

F201, F202: REPLACE WITH SAME TYPE 8A, 125V FUSE.

#### ATTENTION

F201, F202: UTILISER UN FUSIBLE DE RECHANGE DE MEME TYPE DE 8A, 125V.

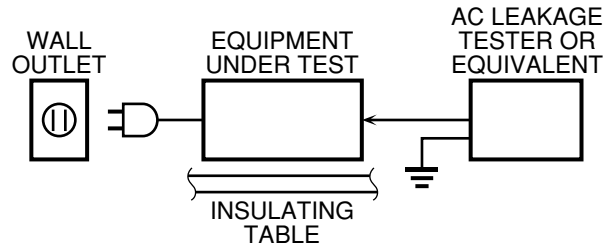

## WARNING: CHEMICAL CONTENT NOTICE!

The solder used in the production of this product contains LEAD. In addition, other electrical/electronic and/or plastic (where applicable) components may also contain traces of chemicals found by the California Health and Welfare Agency (and possibly other entities) to cause cancer and/or birth defects or other reproductive harm.

DO NOT PLACE SOLDER, ELECTRICAL/ELECTRONIC OR PLASTIC COMPONENTS IN YOUR MOUTH FOR ANY REASON WHATSOEVER!

Avoid prolonged, unprotected contact between solder and your skin! When soldering, do not inhale solder fumes or expose eyes to solder/flux vapor!

If you come in contact with solder or components located inside the enclosure of this product, wash your hands before handling food.

## ■ IMPEDANCE SELECTOR

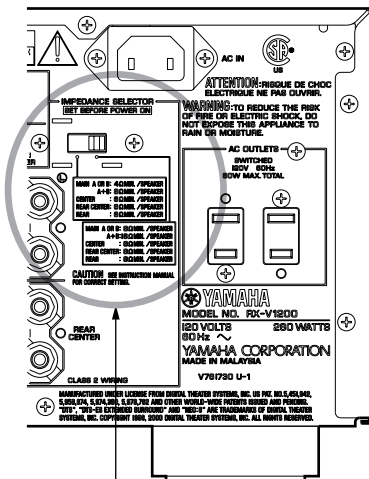

IMPEDANCE SELECTOR

#### WARNING:

Do not change the IMPEDANCE SELECTOR switch setting while the power to this unit is on, otherwise this unit may be damaged.

### • DIMENSIONS

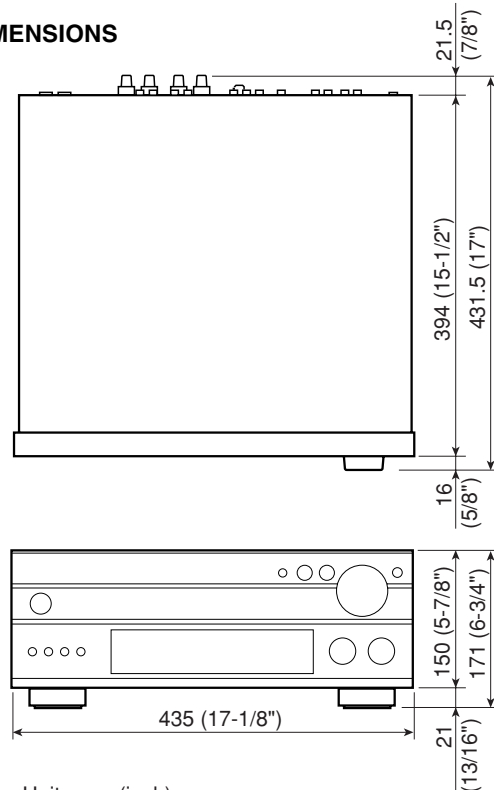

Unit : mm (inch)

# FRONT PANELS

## RX-V1200 (U, C, A, R, T, K models)

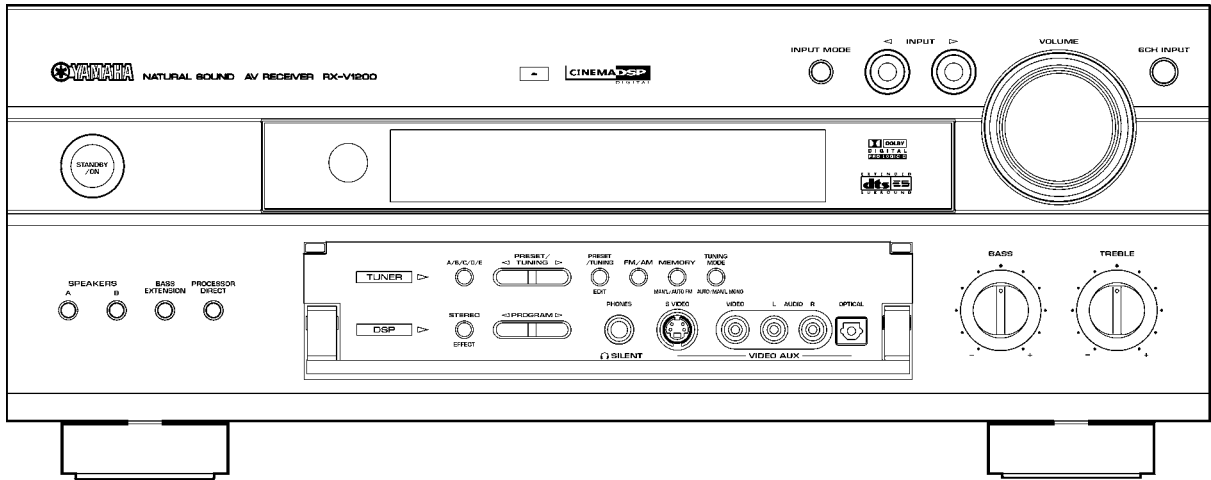

## RX-V1200RDS (B, G models)

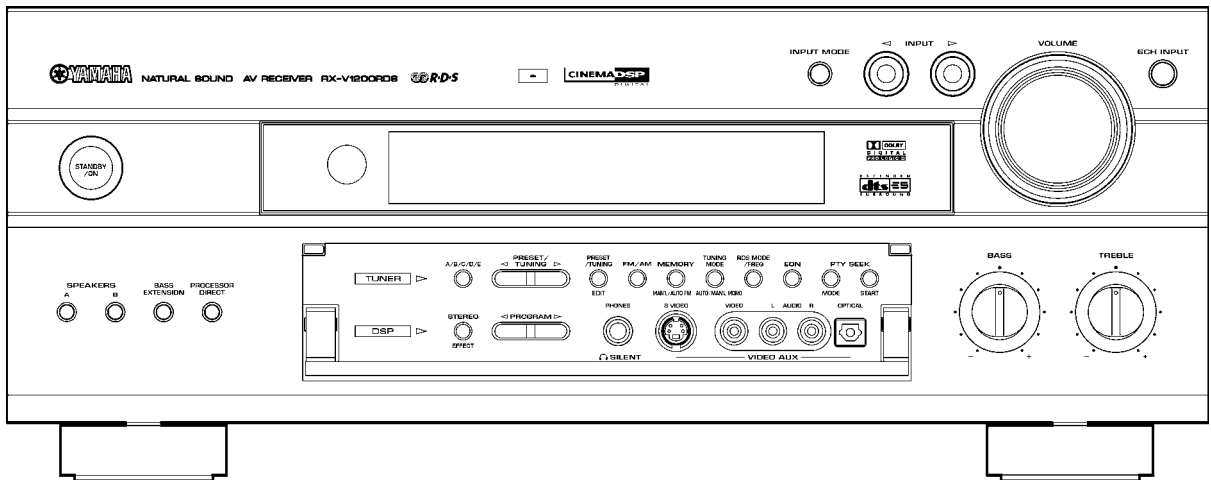

## HTR-5490 (U, C, A, T models)

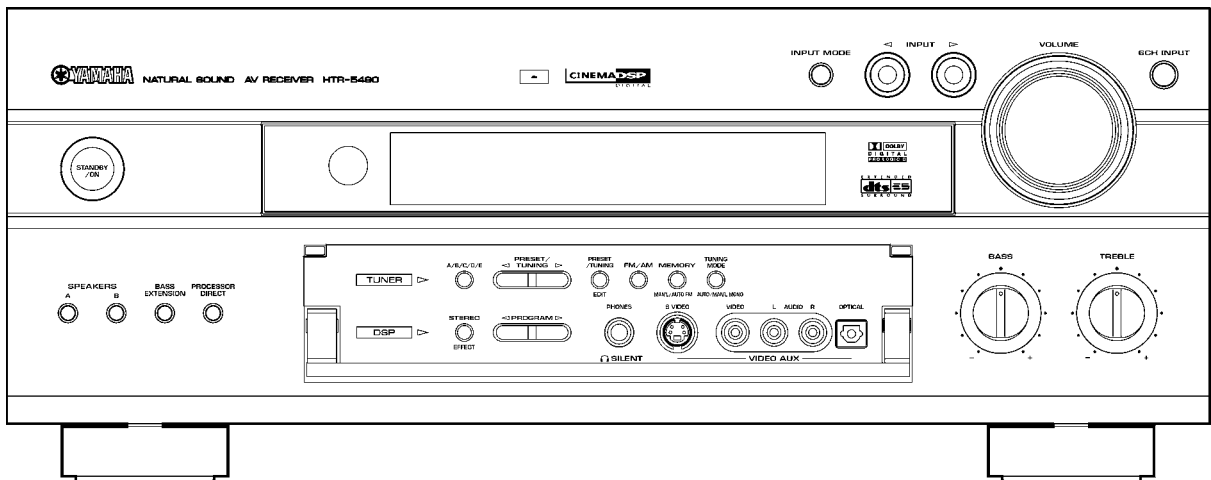

RX-V2200 (U, C, A, R, T models)

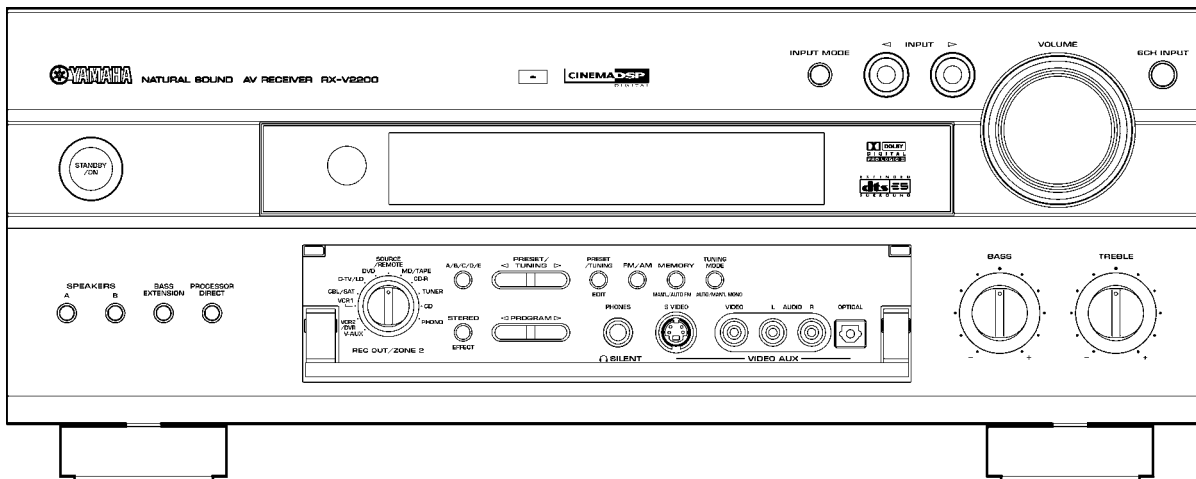

REAR PANELS

RX-V1200 (U model)

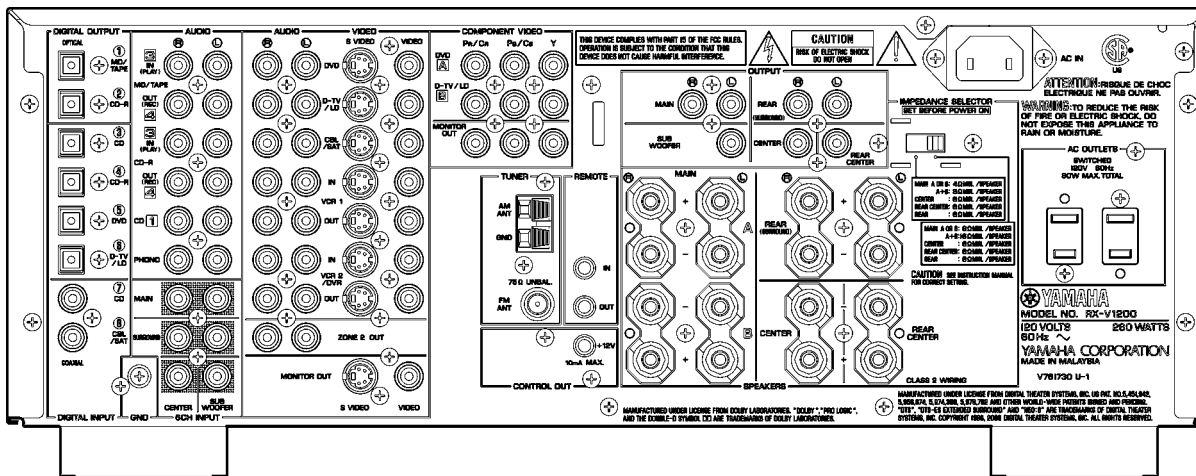

RX-V1200 (C model)

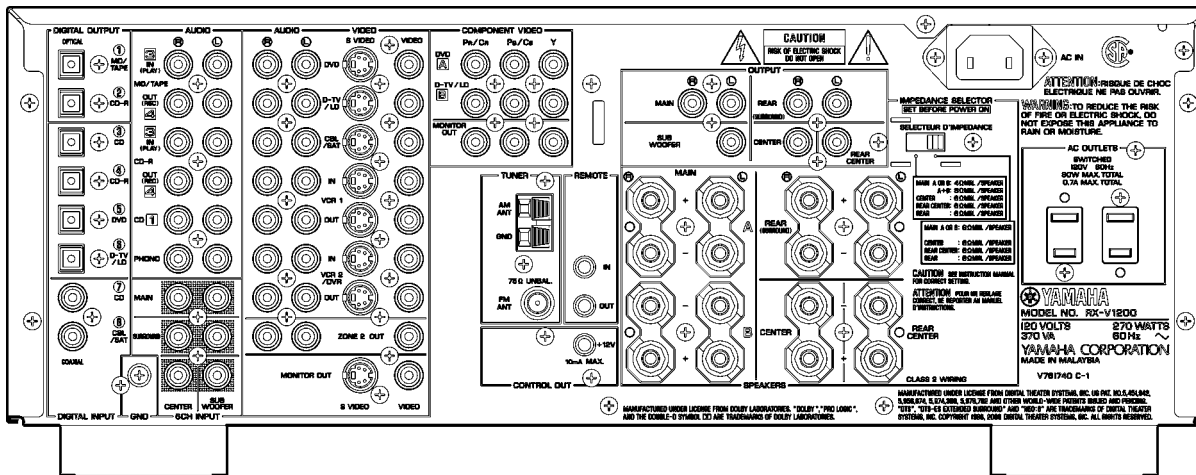

RX-V1200 (A model)

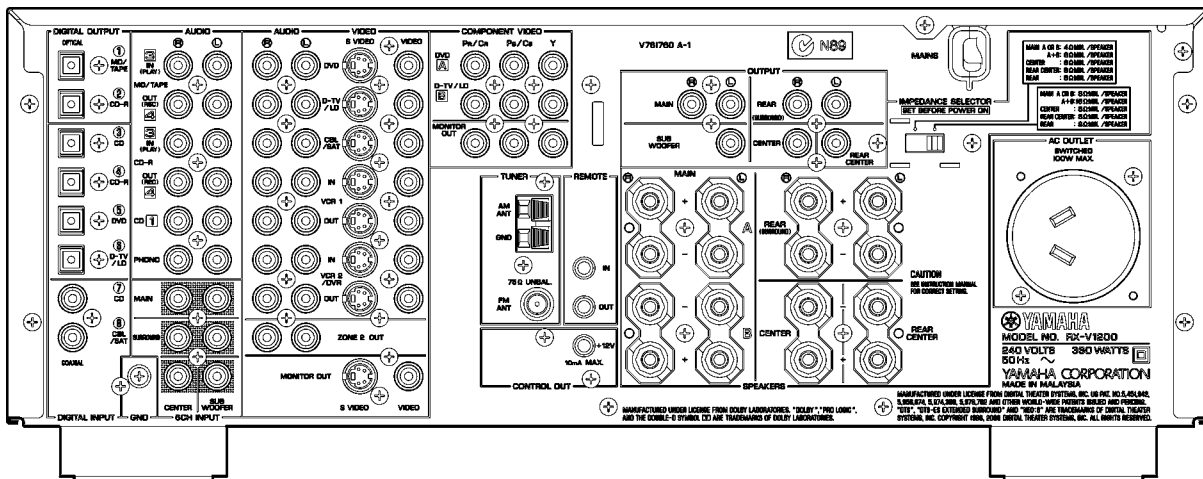

RX-V1200/RX-V1200RDS/HTR-5490/RX-V2200

RX-V1200 (R, T, K models)

AC OUTLETS: R, T models only

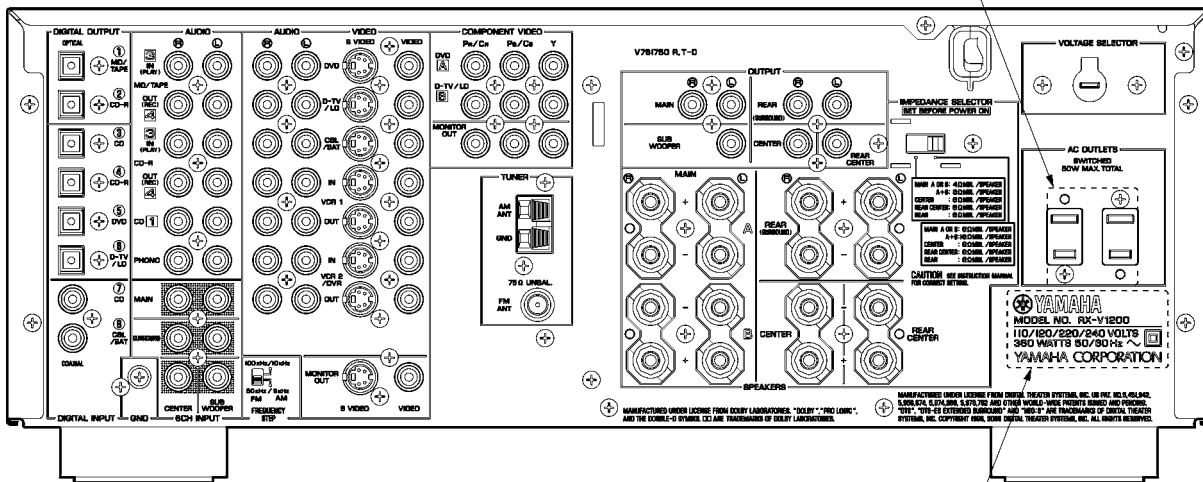

R model

RX-V1200RDS (B model)

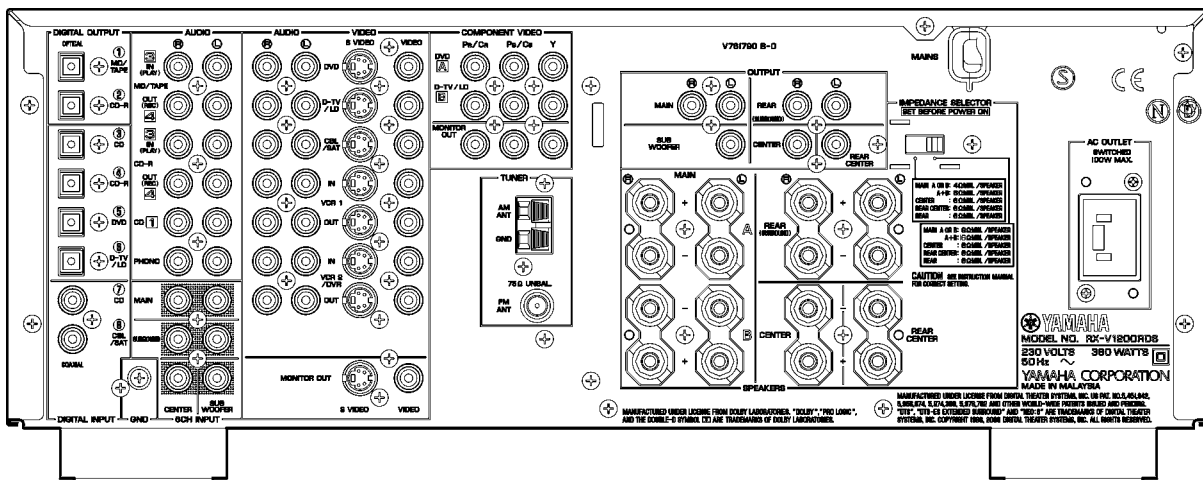

RX-V1200RDS (G model)

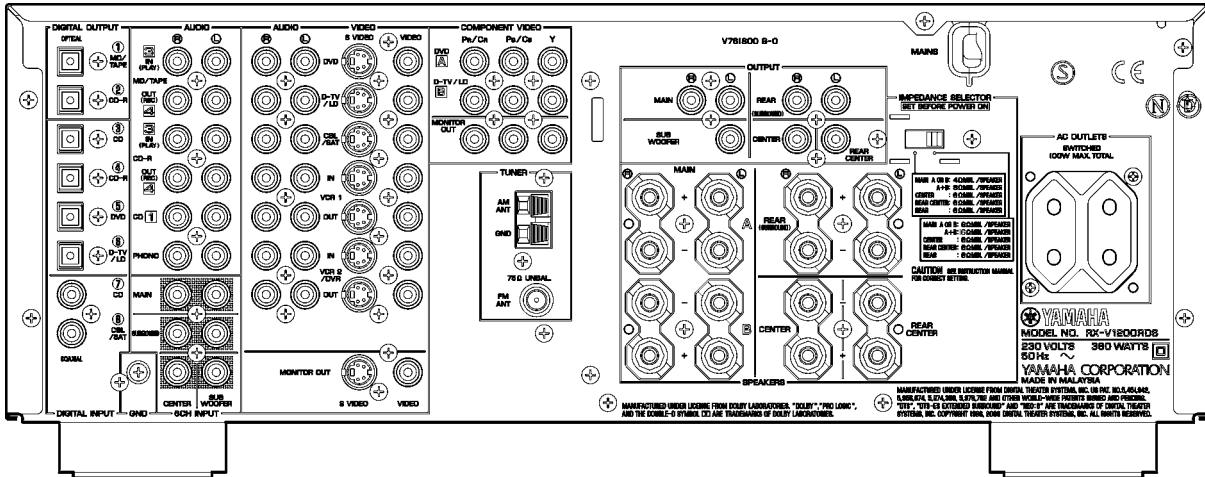

HTR-5490 (U model)

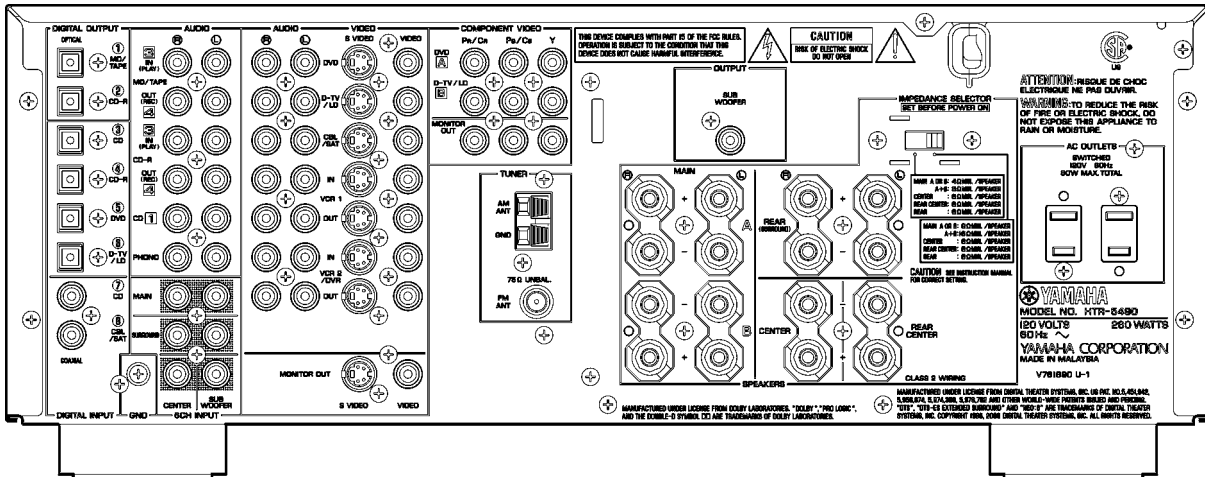

HTR-5490 (C model)

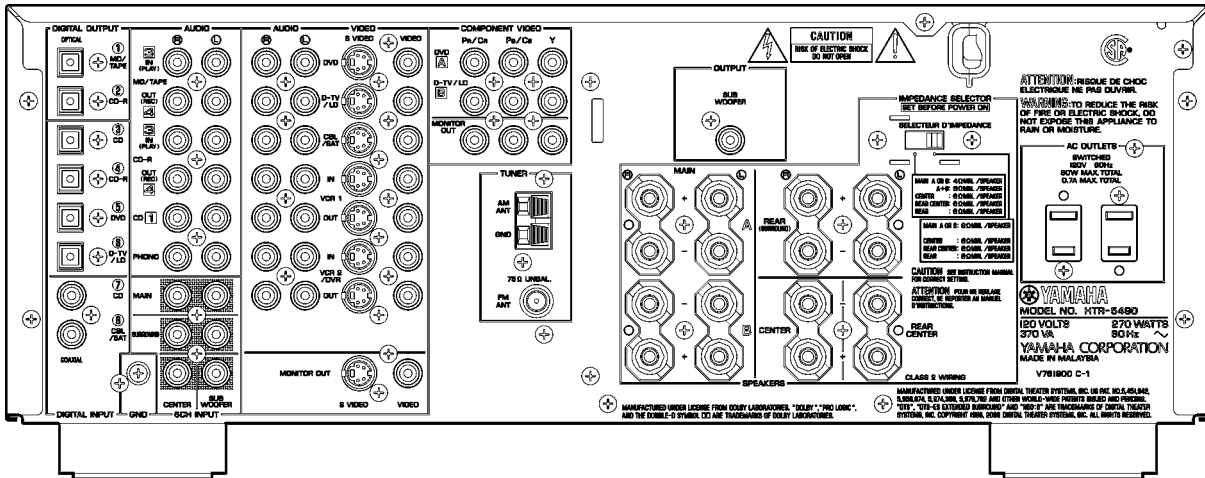

HTR-5490 (A model)

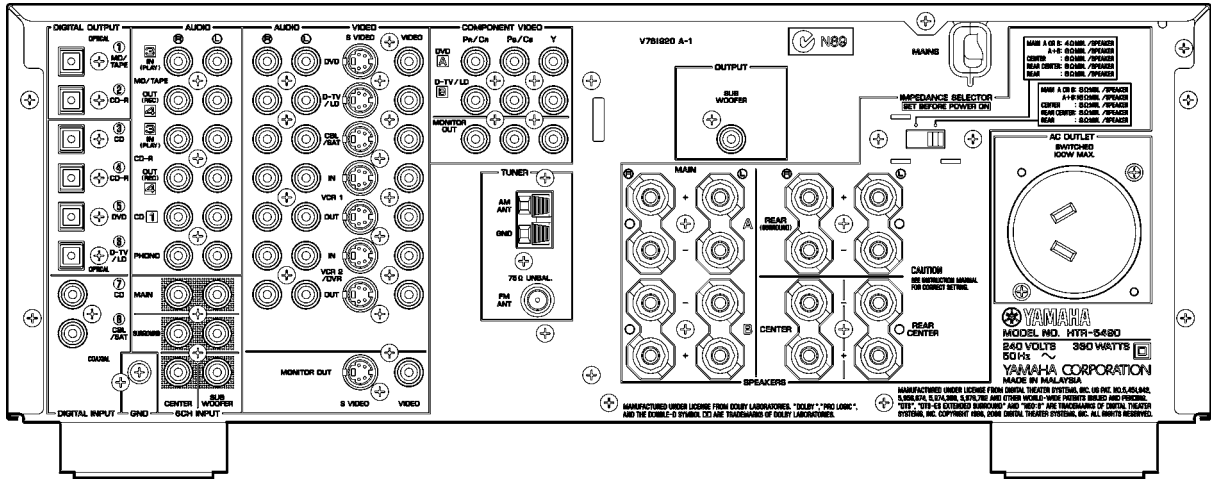

HTR-5490 (T model)

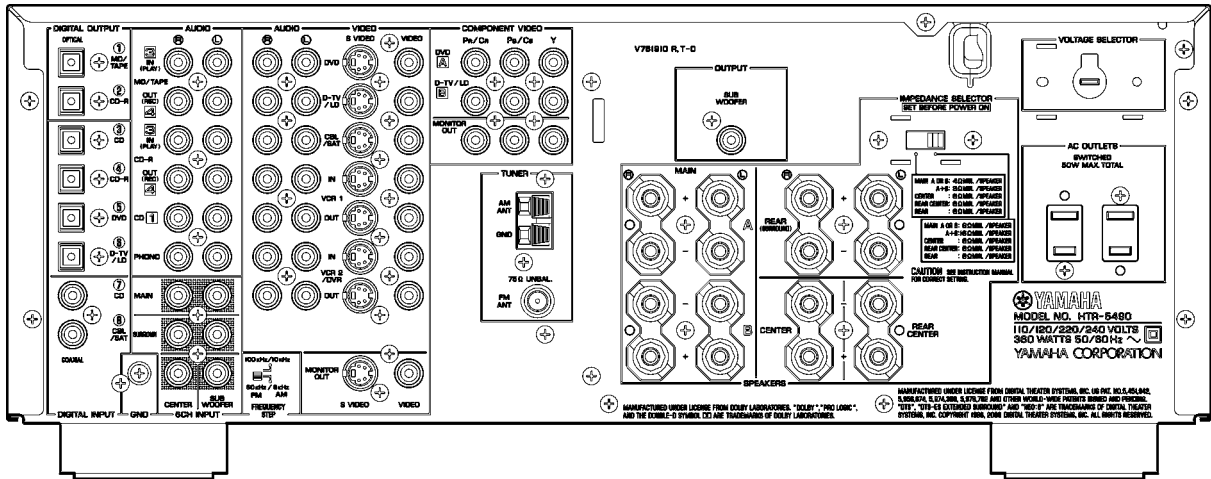

RX-V2200 (U model)

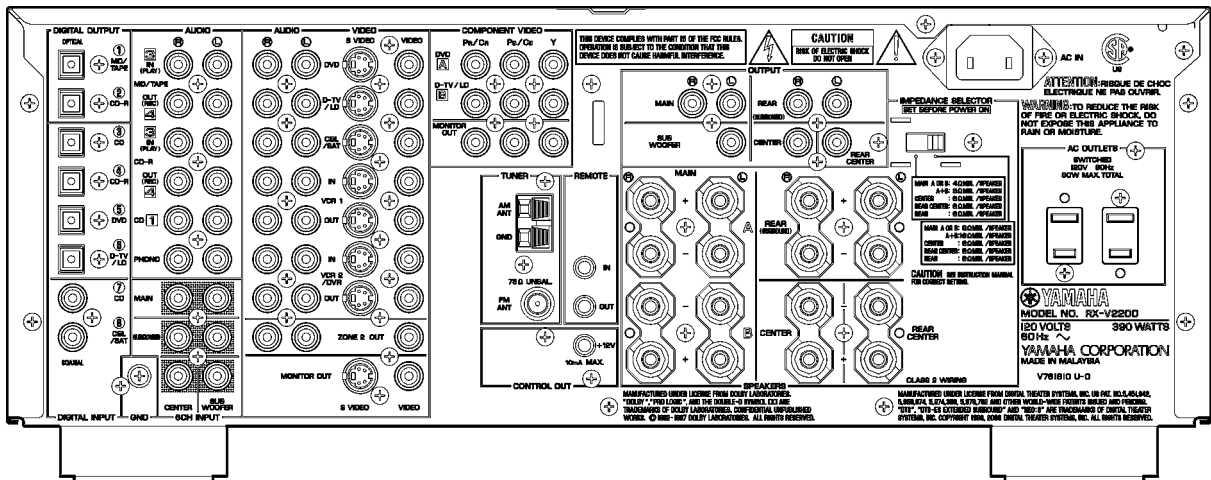

RX-V1200/RX-V1200RDS/HTR-5490/RX-V2200





# REMOTE CONTROL TRANSMITTER

**RX-V1200/HTR-5490**  
(U, C, A, R, T, K models)

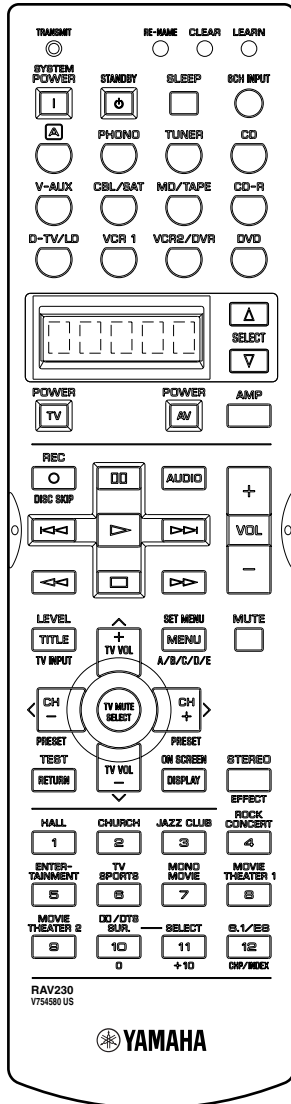

**RX-V1200RDS**  
(B, G models)

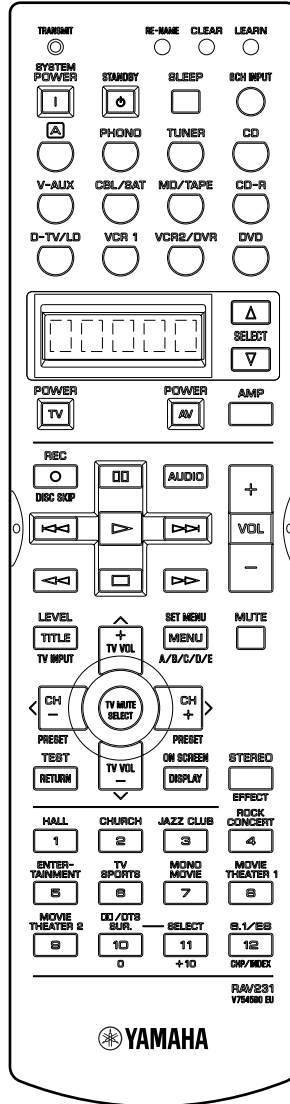

**RX-V2200**

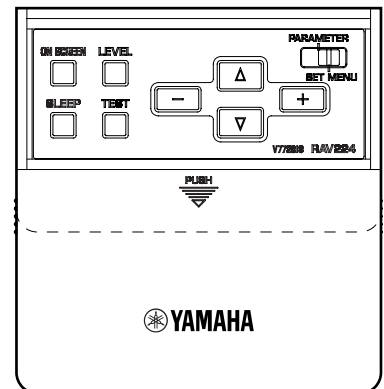
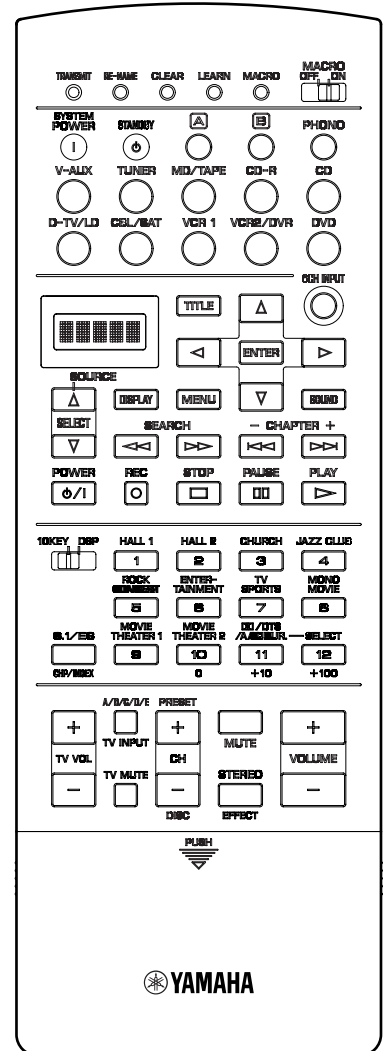

RX-V1200/RX-V1200RDS/  
 HTR-5490/RX-V2200



[R, T models] AC 220V, 50Hz ..... 1.5 W  
 [K model] AC 220V, 60Hz ..... 1.5 W

**Maximum Power Consumption**  
**RX-V1200/RX-V2200 [R model]**  
 5ch Drive, 10% THD ..... 585 W

**AC Outlets**  
 2 switched outlets  
 [U, C models] ..... 80W max., total  
 [G model] RX-V1200RDS only ..... 100W max., total  
 [R, T models] ..... 50W max., total  
 1 switched outlet  
 [A, B models] B: RX-V1200RDS only ..... 100W max.

**Dimensions (W x H x D)**  
 ..... 435 x 171 x 431.5 mm (17-1/8" x 6-3/4" x 17")

**Weight**  
 ..... 15.0 kg (33 lbs. 1 oz.)

**Finish**  
 RX-V1200 ..... Gold color (R, T, K) models  
 Black color (U, C, R, A) models  
 RX-V1200RDS ..... Gold color (G) model  
 Black color (B, G) models  
 Titan color (B, G) models  
 HTR-5490 ..... Gold color (T) model  
 Black color (U, C, A) models  
 RX-V2200 ..... Gold color (R, T) models  
 Black color (U, C, R, A) models

**Accessories**

Remote control transmitter, Manganese batteries, Indoor FM antenna, AM loop antenna, Antenna adaptor [B model], Power cord ass'y [V1200/V2200 U, C models]

\* Specifications are subject to change without notice due to product improvements.

**U** ..... **U.S.A. model**                      **C** ..... **Canadian model**  
**A** ..... **Australian model**                **B** ..... **British model**  
**G** ..... **European model**                 **R** ..... **General model**  
**T** ..... **Chinese model**                    **K** ..... **Korean model**



Manufactured under license from Dolby Laboratories. "Dolby", "Pro Logic" and the double-D symbol are trademarks of Dolby Laboratories.



"DTS" and "DTS Digital Surround" are registered trademarks of Digital Theater Systems, Inc.

**• Set Menu Table**

No.	SET MENU	PRESET VALUE	SETTING RANGES
1.	SPEAKER SET		
1A	CENTER SPEAKER	LARGE	LARGE, SMALL, NONE
1B	MAIN SPEAKER	LARGE	LARGE, SMALL
1C	REAR L/R SPEAKER	LARGE	LARGE, SMALL, NONE
1D	REAR CENTER SPEAKER	LARGE	LARGE, SMALL, NONE
1E	LFE/BASS OUT	BOTH	SUBWOOFER, MAIN, BOTH
1F	MAIN LEVEL	NORMAL	NORMAL, -10dB
2.	LOW FREQ. TEST	TEST TONE : OFF OUTPUT : MAIN L/R FREQ. : 88Hz	OFF, ON MAIN L/R, L, C, R, RS, RC, LS, SWFR 35Hz/ ... /88Hz/ ... /WIDE
3.	L/R BALANCE	CENTER	L, ... , CENTER, ... , R (40 steps)
4.	HP TONE CONTROL	HP BASS : 0dB HP TREBLE : 0dB	-6dB — +3dB (1dB step) -6dB — +3dB (1dB step)
5.	CENTER GRAPHIC EQ.	100Hz : 0dB 300Hz : 0dB 1kHz : 0dB 3kHz : 0dB 10kHz : 0dB	-6dB — +6dB (1dB step) -6dB — +6dB (1dB step) -6dB — +6dB (1dB step) -6dB — +6dB (1dB step) -6dB — +6dB (1dB step)
6.	INPUT RENAME	DVD (Currently selected input)	
7.	I/O ASSIGNING		
7A	COMPONENT VIDEO INPUT 1	[A] : DVD	DVD, D-TV/LD, CABLE, SAT, VCR1, VCR2/DVR, V-AUX
	COMPONENT VIDEO INPUT 2	[B] : D-TV/LD	DVD, D-TV/LD, CABLE, SAT, VCR1, VCR2/DVR, V-AUX
7B	OPTICAL OUT 1	(1) : MD/TAPE	DVD, MD/TAPE, D-TV/LD, CABLE, SAT, VCR1, VCR2/DVR, V-AUX, PHONO, CD, CD-R
	OPTICAL OUT 2	(2) : CD-R	DVD, MD/TAPE, D-TV/LD, CABLE, SAT, VCR1, VCR2/DVR, V-AUX, PHONO, CD, CD-R
7C	OPTICAL IN 1	(3) : CD	CD, CD-R, MD/TAPE, DVD, D-TV/LD, CABLE, SAT, VCR1, VCR2/DVR, PHONO
	OPTICAL IN 2	(4) : CD-R	CD, CD-R, MD/TAPE, DVD, D-TV/LD, CABLE, SAT, VCR1, VCR2/DVR, PHONO
	OPTICAL IN 3	(5) : DVD	CD, CD-R, MD/TAPE, DVD, D-TV/LD, CABLE, SAT, VCR1, VCR2/DVR, PHONO
	OPTICAL IN 4	(6) : D-TV/LD	CD, CD-R, MD/TAPE, DVD, D-TV/LD, CABLE, SAT, VCR1, VCR2/DVR, PHONO
7D	COAXIAL IN 1	(7) : CD	CD, CD-R, MD/TAPE, DVD, D-TV/LD, CABLE, SAT, VCR1, VCR2/DVR, V-AUX, PHONO
	COAXIAL IN 2	(8) : CBL/SAT	CD, CD-R, MD/TAPE, DVD, D-TV/LD, CABLE, SAT, VCR1, VCR2/DVR, V-AUX, PHONO
8.	INPUT MODE	AUTO	AUTO/LAST
9.	PARAMETER INITIALIZE	PARAMETER INITIALIZE	The number key of the remote controller is pushed and initialized.
10.	LFE LEVEL	SPEAKER : 0dB HEADPHONE : 0dB	-2dB — 0dB (1dB step) -2dB — 0dB (1dB step)
11.	DYNAMIC RANGE	SP DYNAMIC RANGE : MAX HP DYNAMIC RANGE : MAX	MAX, STD, MIN MAX, STD, MIN
12.	SPEAKER DELAY TIME	CENTER : 0ms REAR CENTER : 3ms	0ms — 5ms (1ms step) 0ms — 30ms (1ms step)
13.	DISPLAY SET	BLUE BACK : AUTO OSD SHIFT : 0 DIMMER : 0	AUTO/OFF -5 — +5 (1 step) -4 — 0 (1 step)
14.	MEMORY GUARD	OFF	ON/OFF
15.	DUAL MONO	MAIN	MAIN, SUB, ALL

RX-V1200/RX-V1200RDS/HTR-5490/RX-V2200

• The variable range of the parameter (Min/Max/Step)

Parameter name	Pro Logic	Pro Logic II Movie	Pro Logic II Music	Neo:6	2ch	DD/dts/AAC	6.1/ES	Unit
(P.) INIT. DLY	-	-	-	-	1/99/1	1/99/1	1/99/1	ms
(P.) ROOM SIZE	-	-	-	-	0.1/2.0/0.1	0.1/2.0/0.1	0.1/2.0/0.1	-
(P.) LIVENESS	-	-	-	-	0/10/1	0/10/1	0/10/1	-
S. DELAY	10/25/1	10/25/1	0/15/1	0/30/1	0/49/1	0/49/1	0/49/1	ms
S. INIT. DLY	-	-	-	-	-	1/49/1	1/49/1	ms
S. ROOM. SIZE	-	-	-	-	0.1/2.0/0.1	0.1/2.0/0.1	0.1/2.0/0.1	-
S. LIVENESS	-	-	-	-	0/10/1	0/10/1	0/10/1	-
RC. INT.DLY	-	-	-	-	-	-	1/49/1	ms
RC. ROOM, SIZE	-	-	-	-	-	-	0.1/2.0/0.1	-
RC. LIVENESS	-	-	-	-	-	-	0/10/1	-
REV. TIME	-	-	-	-	1.0/5.0/0.1	1.0/5.0/0.1	1.0/5.0/0.1	s
REV. DELAY	-	-	-	-	0/250/1	0/250/1	0/250/1	ms
REV. LEVEL	-	-	-	-	0/100/1	0/100/1	0/100/1	%
Panorama	-	OFF	OFF/ON	-	-	-	-	-
Dimension	-	0 (STD)	-3/+3/1	-	-	-	-	-
C Width	-	0	0/7/1	-	-	-	-	-

6ch Stereo Parameter		Unit
CT. LEVEL	0/100/1	%
RL. LEVEL	0/100/1	%
RC. LEVEL	0/100/1	%
RR. LEVEL	0/100/1	%

■ INTERNAL VIEW

- ① POWER (1) P.C.B.
- ② POWER (7) P.C.B.
- ③ MAIN (6) P.C.B.
- ④ MAIN (4) P.C.B.
- ⑤ MAIN (5) P.C.B.
- ⑥ POWER (10) P.C.B.
- ⑦ TUNER
- ⑧ VIDEO (4) P.C.B.
- ⑨ VIDEO (2) P.C.B.
- ⑩ VIDEO (1) P.C.B.
- ⑪ VIDEO (6) P.C.B.
- ⑫ VIDEO (8) P.C.B.
- ⑬ VIDEO (7) P.C.B.
- ⑭ VIDEO (5) P.C.B.
- ⑮ DSP P.C.B.
- ⑯ FUNCTION P.C.B.
- ⑰ POWER (4) P.C.B.
- ⑱ MAIN (1) P.C.B.
- ⑲ OPERATION (5) P.C.B.
- ⑳ OPERATION (4) P.C.B.
- ㉑ MAIN (2) P.C.B.
- ㉒ OPERATION (2) P.C.B.
- ㉓ POWER (8) P.C.B.
- ㉔ OPERATION (6) P.C.B.  
(RX-V2200 only)
- ㉕ OPERATION (1) P.C.B.
- ㉖ OPERATION (3) P.C.B.
- ㉗ POWER (3) P.C.B.
- ㉘ OPERATION (7) P.C.B.
- ㉙ POWER (5) P.C.B.
- ㉚ POWER (2) P.C.B.
- ㉛ MAIN (7) P.C.B.
- ㉜ MAIN (3) P.C.B.

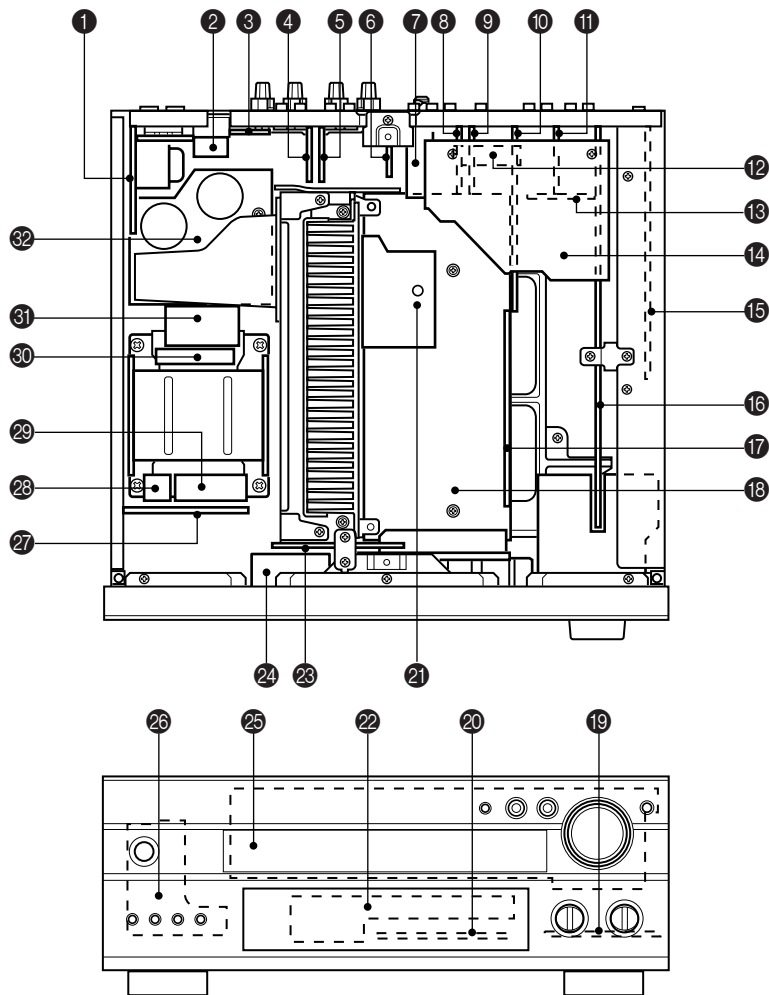

RX-V1200/RX-V1200RDS/HTR-5490/RX-V2200

## DISASSEMBLY PROCEDURES

(Remove parts in the order as numbered.)  
Disconnect the power cord from the AC outlet.

### 1. Removal of Top Cover

- Remove 2 screws (1), 4 screws (2) and 5 screws (3). (Fig. 1)
- Slide the Top Cover rearward to remove it. (Fig. 1)

### 2. Removal of Front Panel

- Remove the BASS and TREBLE knobs (4). (Fig. 1)
- Remove 9 screws (5) and then remove the Front Panel forward. (Fig. 1)

### 3. Removal of Sub Chassis

- Remove 4 push rivets (6) and then remove the Side Plates. (Fig. 2)
- Remove 2 screws (7) and 2 screws (8), and then remove the Sub Chassis forward. (Fig. 2)

### 4. Removal of DSP P.C.B.

- Remove 2 screws (9) and then remove the Supports. (Fig. 2)
- Remove 4 screws (10) and then remove the Brackets. (Fig. 2)
- Remove 1 screw (11). (Fig. 2)
- Remove 9 screw (12). (Fig. 3)
- Remove the DSP P.C.B. upward. (Fig. 2)

### 5. Removal of VIDEO (5) P.C.B.

- Remove 2 screws (13). (Fig. 2)
- Remove the VIDEO (5) P.C.B. which is connected directly to the lower P.C.B. with connectors. (Fig. 2)

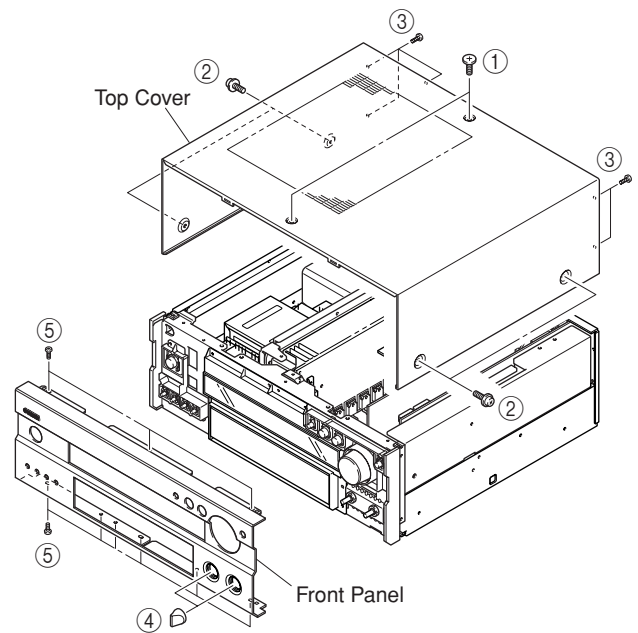

Fig. 1

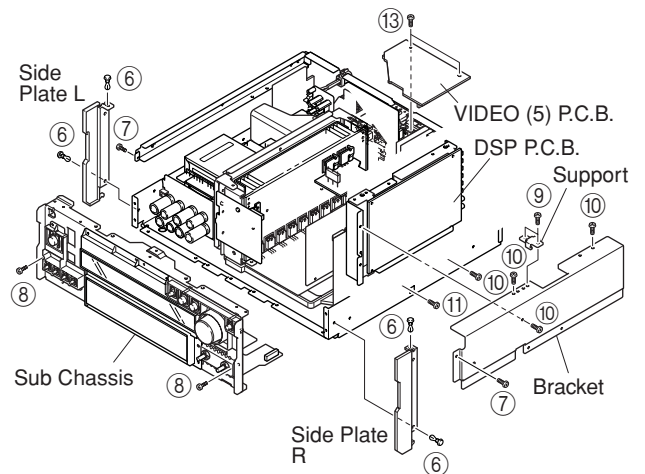

Fig. 2

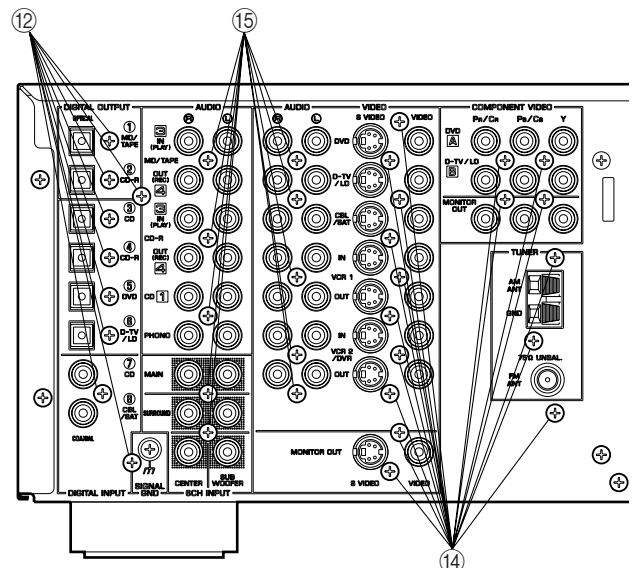

Fig. 3

## 6. Removal of VIDEO (1), VIDEO (2), VIDEO (4) and VIDEO (8) P.C.B.s and Tuner

- Remove 17 screws (14). (Fig. 3)
- Remove VIDEO (1), VIDEO (2), VIDEO (4) and VIDEO (8) P.C.B.s and the Tuner. (Fig. 4)

### When checking the P.C.B.:

- Put the rubber sheet and a cloth over the equipment. Then place the P.C.B. upside down on the cloth and check it. (Fig. 4)
- Connect VIDEO (5) and FUNCTION P.C.B.s by using the extension cable (AAX30610) for the P.C.B. check. (Fig. 6)
- Reconnect all cables (connectors) that have been disconnected.
- The P.C.B. removed from the rear panel does not work because its grounding is loose. Be sure to connect the ground of each P.C.B. to the chassis or GND with a jumper wire or the like.

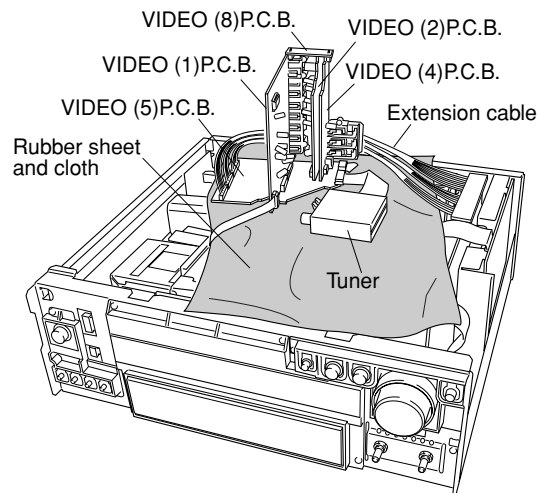

Fig. 4

## 7. Removal of VIDEO (6), VIDEO (7), and FUNCTION P.C.B.s

- Remove CB212, CB975, CB510, CB509, CB505 and CB503. (Fig. 5)
- Remove 9 screws (15). (Fig. 3)
- Remove VIDEO (6), VIDEO (7), and FUNCTION P.C.B.s. (Fig. 6)

### When checking the P.C.B.:

- Put a cloth beside the equipment. Then place the P.C.B. on the cloth and check it. (Fig. 4)
- Connect VIDEO (5) and FUNCTION P.C.B.s by using the extension cable (AAX30610) for the P.C.B. check. (Fig. 6)
- Reconnect all cables that have been disconnected.
- The P.C.B. removed from the rear panel does not work because its grounding is open. Be sure to connect the ground of each P.C.B. to the chassis or GND with a jumper wire or the like.

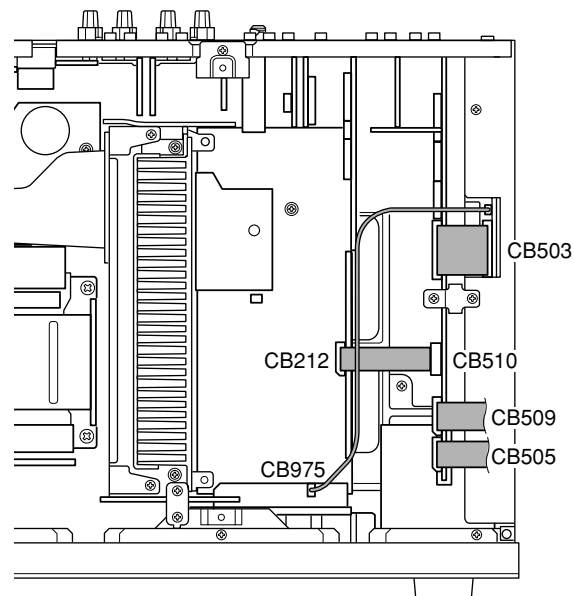

Fig. 5

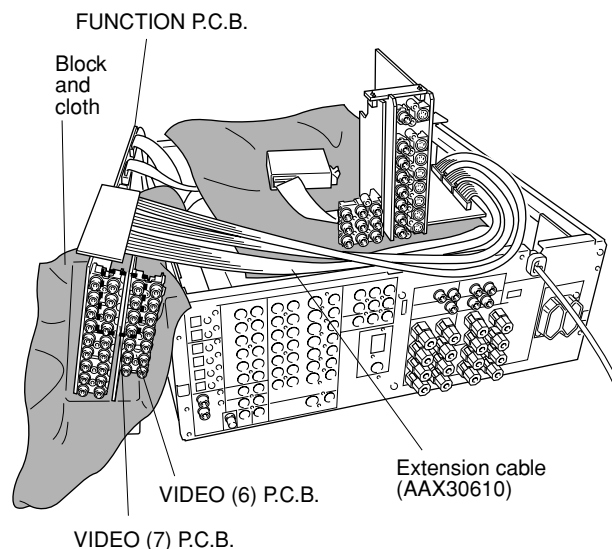
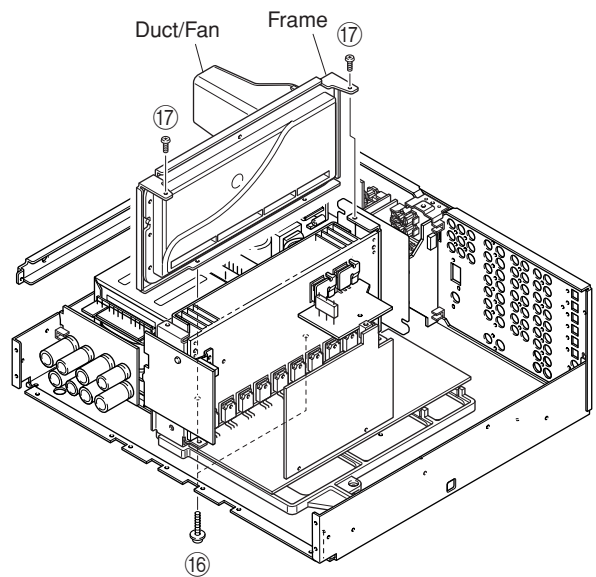

Fig. 6

**8. Removal of Duct/Fan Section (If applicable)**

- a. Remove 2 screws (16) and 2 screws (17). (Fig. 7)
- b. Remove the duct/fan together with the frame by lifting them up.



**Fig. 7**

**9. Removal of MAIN (1), MAIN (2), POWER (4) and POWER (8) P.C.B.'s.**

- a. Remove 2 screws (18), 3 screws (19) and 1 screw (20). (Fig. 8)
- b. Remove MAIN (1), MAIN (2), POWER (4) and POWER (8) P.C.B.s. (Fig. 8)

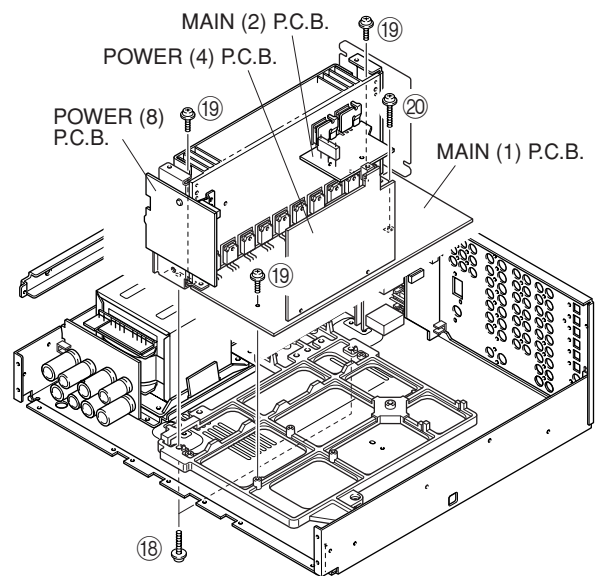

**Fig. 8**

## ■ SELF DIAGNOSIS FUNCTION (DIAG)

There are 18 DIAG menu items, each of which has sub-menu items. Listed in the table below are menu items and sub-menu items. (Some diagnostic functions do not apply to all models or to all markets.)

No	DIAG menu	sub-menu
1	YSS938 1. ANALOG BYPASS	1. ANALOG BYPASS
		2. YSS 0dB
		3. YSS FULL BIT
2	YSS-CS 2. YSS-CS 0dB	1. YSS-CS 0dB
		2. YSS-CS FULL BIT
3	CS-YSS 3. CS-YSS 0dB	1. CS-YSS 0dB
		2. CS-YSS FULL BIT
4	CS49329 4. CS 0dB	1. CS49329 0dB
		2. CS49329 FULL BIT
5	HP ROUTE 5. HP 0dB	1. HP 0dB
		2. HP FULL BIT
6	RAM THROUGH 6. RAM 0dB	1. RAM 0dB
		2. MAIN ATT
7	DOLBY PRO LOGIC 7. PRO LOGIC I	1. PRO LOGIC I
		2. PRO LOGIC II
		3. NEO: 6
8	SPEAKER SET 8. MAIN: SML 0dB	1. MAIN: SMALL 0dB
		2. MAIN: LARGE -10dB
		3. CENTER: NONE
		4. LFE/BASS: MAIN
		5. FRONT MIX: 5ch
		6. REAR C: MUTE
		7. REAR L/R: MUTE
9	EFFECT OFF/ DISPLAY CHECK 9. VFD CHECK	1. VFD CHECK (Initial display)
		2. VFD DISP OFF (All segments OFF)
		3. VFD DISP ALL (All segments ON 100%)
		4. VFD DIMMER (All segments ON 50%)
		5. CHECKED PATTERN (ON in lattice)
10	MANUAL TEST 10 TEST ALL	1. TEST ALL
		2. TEST MAIN L
		3. TEST CENTER
		4. TEST MAIN R
		5. TEST REAR R
		6. TEST REAR CENTER
		7. TEST REAR L
		8. TEST LFE
11	RS-232C 11 TxRxData:XX	1. TX DATA
		2. HARD FLOW
12	FACTORY PRESET 12 PRESET INHI	1. PRESET INHIBIT (memory initialization inhibited)
		2. PRESET RESERVED (memory initialized)
13	AD DATA CHECK /FAN TEST DC:007 PS:025	1. DC/PS (protection)
		2. THM/FAN OUT
		3. REC-OUT
		4. IMP SW/POWER LIMIT
		5. K0/K1 (panel key)
		6. FAN DRIVE TEST: HIGH (Fan test only applies to models with a fan.)
		7. FAN DRIVE TEST: MID (Fan test only applies to models with a fan.)
		8. FAN DRIVE TEST: LOW (Fan test only applies to models with a fan.)



No	DIAG menu	sub-menu
14	IF STATUS IS1: 440308C000	1. IS 1
		2. IS 2
		3. IS 3
		4. CS 1
		5. CS 2
		6. CS 3
		7. CS 4
		8. CS 5
		9. BY1
		10. BY2
		11. BY3
		12. BY4
		13. BC1
		14. BC2
		15. BC3
		16. BC4
		17. BC5
		18. YS1
		19. YS2
		20. YS3
		21. CS
		22. MTT
15	DSP RAM CHECK VSS Bus: NoEr	1. YSS938 BUS CHECK
		2. PLD/SRAM BUS CHECK
16	CS DL CODE RDV: X	1. ROM DATA VERSION
		2. TOC AREA 0
		3. TOC AREA 1
		4. TOC AREA 2
		5. TOC AREA 3
		6. TOC AREA 4
		7. TOC AREA 5
		8. SUM CHECK AREA 0
		9. SUM CHECK AREA 1
		10. SUM CHECK AREA 2
		11. SUM CHECK AREA 3
		12. SUM CHECK AREA 4
		13. SUM CHECK AREA 5
17	SOFT SW 17. SW : PCB	1. SW MODE
		2. MODEL SETTING
		3. TUNER DESTINATION
		4. TUNER EXIST
		5. RDS EXIST
		6. ZONE 2 EXIST
		7. VIDEO FORMAT
18	ROM VERSION/CHECK SUM/ PORT VER. XXXXXXXX	1. VERSION
		2. SUM ALL/PROGRAM
		3. SUM 232C/MAKER
		4. PORT
		5. AAC PORT

**• Starting DIAG**

Press the “STANDBY/ON key while pressing those two keys indicated in the figure on the right.

**• Starting DIAG in the protection cancel mode**

If the protection function works and causes hindrance to trouble diagnosis, cancel the protection function as described below, and it will be possible to enter the DIAG mode. (The protection functions other than the excess current detect function will be cancelled.)

Press the “STANDBY/ON key while pressing those two keys indicated in the figure on the right. At this time, keep pressing those two keys for 3 seconds or longer.

In this mode, the “SLEEP” segment of the FL display of the main unit flashes to indicate that the mode is DIAG mode with the protection functions cancelled.

**CAUTION!**

Using this product with the protection function disabled may cause damage to itself. Use special care for this point when using this mode.

**• Canceling DIAG**

[1] Before canceling DIAG, execute setting for PRESET of DIAG menu No.12 (Memory initialization inhibited or Memory initialized).

\* In order to keep the user memory stored, be sure to select PRESET INHI (Memory initialization inhibited).

[2] Turn off the power by pressing the “STANDBY/ON” key of the main unit or the “STANDBY” key of the remote controller.

**• Display provided when DIAG started**

When the monitor is connected, DIAGNOSTIC MENU appears on its screen as shown in the figure. (It remains on display until DIAG is cancelled.)

DIAGNOSTIC MENU	
1. DSP THR	10. MAN LTEST
2. YSS-CS	11. RS232C
3. CS-YSS	12. PRESET
4. CS49329	13. AD/FAN
5. HP ROUTE	14. STATUS
6. RAM THR	15. DSP RAM
7. PRO LOGIC	16. CS DL COD
8. SP SET	17. SOFT SW
9. VFD CHECK	18. VER/SUM/P

The FL display of the main unit displays the protection function history data and the version (1 alphabet) and the DIAG menu (sub-menu (ANALOG BYPASS) of DIAG menu No.1 YSS938) a few seconds later.

**When there is no history of protection function:**

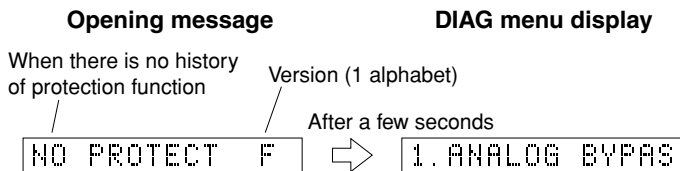

**When there is a history of protection function:**

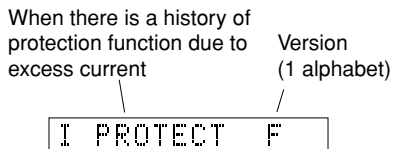

**Cause:** An excessive current flowed through the power amplifier.

**Supplementary information:** As current of the power transistor is detected, the abnormal channel can be identified by checking the current detect transistor.

Turning on the power without correcting the abnormality will cause the protection function to work immediately and the power supply will instantly be shut off.

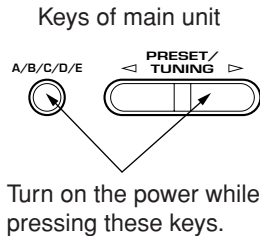

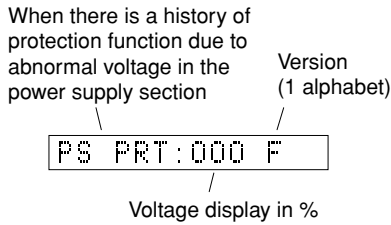

**Cause:** The voltage in the power supply section is abnormal.  
**Supplementary information:** The abnormal voltage is displayed in % based on 5V as 100%.

Turning on the power without correcting the abnormality will cause the protection function to work 1 second later and the power supply will be shut off.

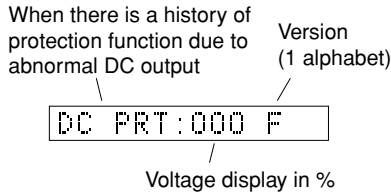

**Cause:** DC output of the power amplifier is abnormal.  
**Supplementary information:** The abnormal voltage is displayed in % based on 5V as 100%.

Turning on the power without correcting the abnormality will cause the protection function to work 3 seconds later and the power supply will be shut off.

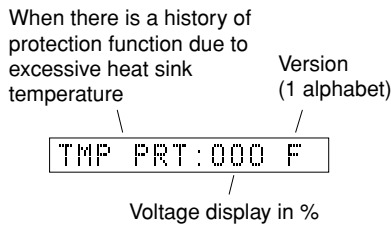

**Cause:** The temperature of the heat sink is excessive.  
**Supplementary information:** The abnormal voltage is displayed in % based on 5V as 500%.

Turning on the power without correcting the abnormality will cause the protection function to work 1 second later and the power supply will be shut off.

- \* Additional causes of protection can be due to loose connections, associated components, CPU, etc.
- \* For the protection voltage value, refer to DIAG menu No.10 described later.

**• History of protection function**

When the protection function has worked, its history is stored in memory with a backup. Even if no abnormality is noted while servicing the unit, an abnormality which has occurred previously can be defined as long as the backup data has been stored.

The history of the protection function is cleared when DIAG is cancelled by selecting PRESET RESERVED (Memory initialized) of DIAG menu No.10 or when the backup data is erased.

**• Display during menu operation**

During the DIAG operation, the menu list described in the section of the startup screen appears on the superimposed screen and the function at work is indicated on the FL indicator. The contents displayed during the function operation are described in the later section on details of functions.

**• Operation procedure of DIAG menu and SUB-MENU**

There are 18 MENU items, each of which has some SUB-MENU items.

**DIAG menu selection**

Main unit: Select the menu using ▷ (Forward) and ◁ (Reverse) keys of PRESET/TUNING located in the sealing panel.

Remote control unit: Select the menu using ∨ (Forward) and ∧ (Reverse) keys.

**SUB-MENU selection**

Main unit: Select the sub-menu using ▷ (Forward) and ◁ (Reverse) keys of PROGRAM located in the sealing panel.

Remote control unit: Select the sub-menu using > (Forward) and < (Reverse) keys.

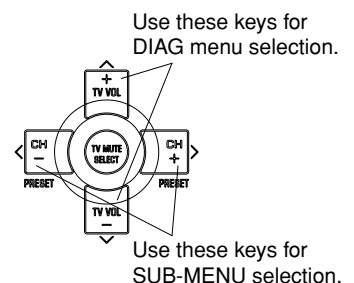
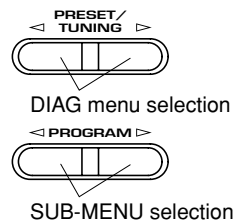

## • Functions in DIAG mode

In addition to the DIAG menu items, functions as listed below are available.

- Input selection, 6CH input
- Center/Rear/Rear Center/Sub-woofer level adjustment
- Muting
- Speaker relay A/B
- Power on/off
- Master volume

\* Functions related to the tuner and the set menu are not available.

\* It is possible to confirm Menu No.14 IF STATUS while keeping the signal process (operation status) of each DIAG menu by using the input mode key of the main unit.

## • Initial settings used to start DIAG

The following initial settings are used when starting DIAG.

When DIAG is canceled, these settings are restored to those before starting DIAG.

- Master volume: -40dB
- Input: DVD (6CH INPUT OFF)
- Effect level: 0dB
- Audio mute: OFF
- Speaker relay A/B: ON
- Speaker setting: LARGE / BASS OUT = BOTH
- DIAG menu: YSS938 (1. ANALOG BYPASS)

• **Details of DIAG menu**

With full-bit output specified in some modes, it is possible to execute 0dBFS output without head margin in each channel.

**1. YSS938**

This function is for YSS938 only. Main DSP of YSS938 is selected for MAIN L/R output.

Using the sub-menu, it is possible to select the analog bypass, 0dB output level or full-bit output.

**ANALOG BYPASS**

1. ANALOG BYPASS

- The signal is output through the signal path as shown below.
- The signal for L/R is output as it is without passing through the DSP section.

Reference data (PRE OUT)  
 INPUT: DVD ANALOG  
 SWFR: 50Hz, Others: 1kHz

Condition	MAIN L/R	CENTER	REAR C	SWFR	RL/RR
Both ch, -20 dBV, volume -10 dB	-5.5 dBV	-5.5 dBV	-5.5 dBV	-2.5 dBV	-5.5 dBV

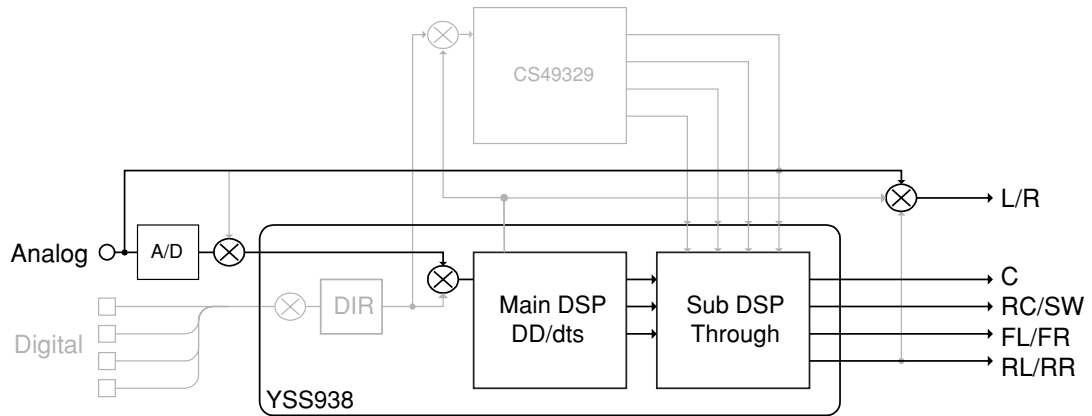

**YSS 0dB**

1. YSS 0dB

- The signal is output including the head margin.

Head margin:

Main L/R: 0dBFS, Center: -6dBFS, Rear Center: -3dBFS, FL/FR: -6dBFS, RL/RR: -12dBFS, SWFR: Add L/R signal at -20dBFS.

Reference data (PRE OUT)

INPUT: DVD ANALOG

SWFR: 50Hz, Others: 1kHz

Condition	MAIN L/R	CENTER	REAR C	SWFR	RL/RR
Both ch, -20 dBV, volume -10 dB	-5.5 dBV	-5.5 dBV	-5.5 dBV	-2.5 dBV	-5.5 dBV

**YSS FULL BIT**

1. YSS FULL BIT

- The signal is output in digital full bit without including the head margin.

Reference data (PRE OUT)

INPUT: DVD ANALOG

SWFR: 50Hz, Others: 1kHz

Condition	MAIN L/R	CENTER	REAR C	SWFR	RL/RR
Both ch, -20 dBV, volume -10 dB	-5.5 dBV	+0.5 dBV	-3.0 dBV	-2.5 dBV	+6.5 dBV

DSP THROUGH ~  
YSS (Analog)

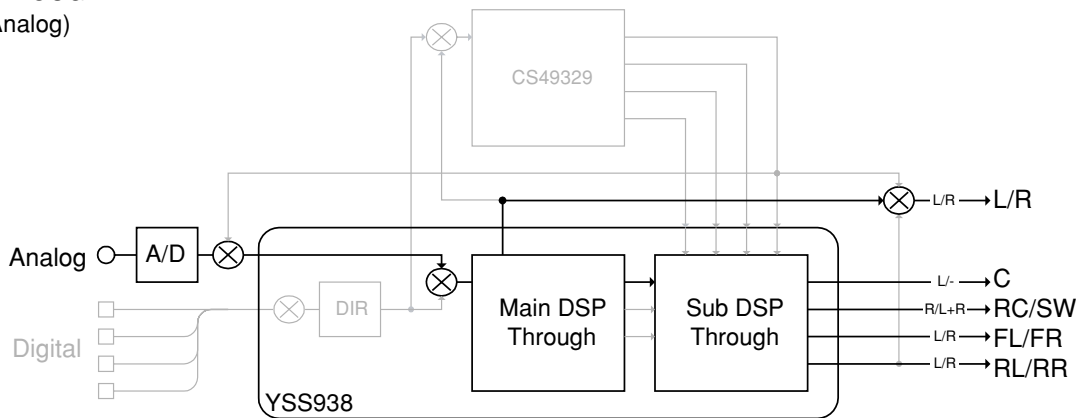

DSP THROUGH ~  
YSS (DD/dts (ES off))

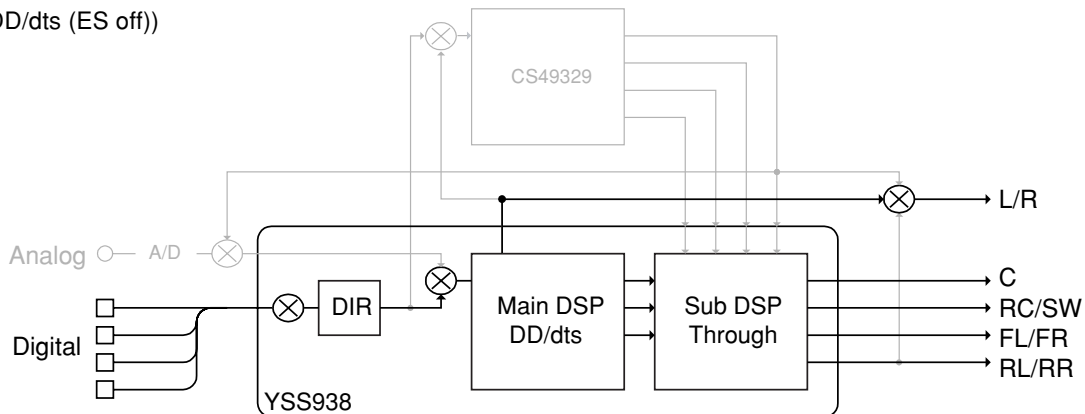

RX-V1200/RX-V1200RDS/HTR-5490/RX-V2200

## 2. YSS-CS

8 channels are made usable by CS49329. The signal enters YSS938 through the Sub DSP passage and then undergoes through-output.

CS49329 is selected for the Main L/R output. Using the sub-menu, it is possible to select full bit output at 0dB output level.

### YSS-CS 0dB

2. YSS-CS 0dB

- The signal is output including the head margin.  
Head margin:

Main L/R: -18dBFS, Center: -6dBFS, Rear Center: -3dBFS, FL/FR: -6dBFS, RL/RR: -18dBFS, SWFR: Add L/R signal at -20dBFS.

Reference data (PRE OUT)  
INPUT: DVD ANALOG  
SWFR: 50Hz, Others: 1kHz

Condition	MAIN L/R	CENTER	REAR C	SWFR	RL/RR
Both ch, -20 dBV, volume -10 dB	-5.5 dBV	-5.5 dBV	-5.5 dBV	-2.5 dBV	-5.5 dBV

### YSS-CS FULL BIT

2. YSS-CS F BIT

- The signal is output in digital full bit without including the head margin.

Reference data (PRE OUT)  
INPUT: DVD ANALOG  
SWFR: 50Hz, Others: 1kHz

Condition	MAIN L/R	CENTER	REAR C	SWFR	RL/RR
Both ch, -20 dBV, volume -10 dB	-5.5 dBV	+0.5 dBV	-3.0 dBV	-2.5 dBV	+6.5 dBV

DSP THROUGH ~  
YSS-CS (Analog)

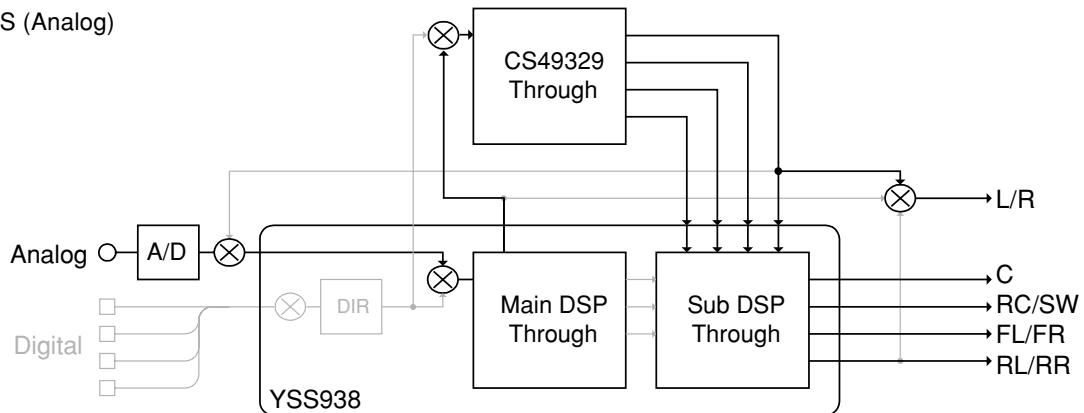

DSP THROUGH ~  
YSS-CS (DD/dts (ES off))

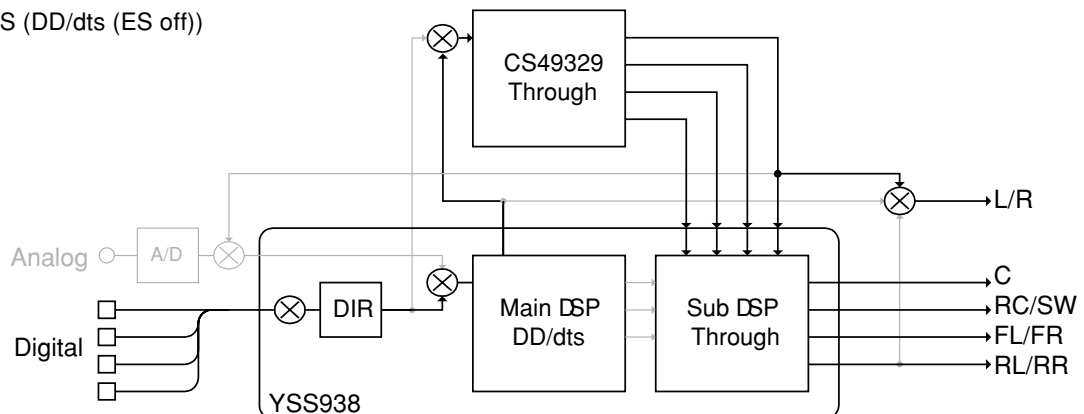

### 3. CS-YSS

8 channels are made usable by CS49329. The signal enters YSS938 through the Sub DSP passage and then undergoes through-output.

YSS938 Main DSP is selected for the Main L/R output. Using the sub-menu, it is possible to select full bit output at 0dB output level.

#### CS-YSS 0dB

3. CS-YSS 0dB

- The signal is output including the head margin.

Head margin:

Main L/R: -18dBFS, Center: -6dBFS, Rear Center: -3dBFS, FL/FR: -6dBFS, RL/RR: -18dBFS, SWFR: Add L/R signal at -20dBFS.

Reference data (PRE OUT)

INPUT: DVD ANALOG

SWFR: 50Hz, Others: 1kHz

Condition	MAIN L/R	CENTER	REAR C	SWFR	RL/RR
Both ch, -20 dBV, volume -10 dB	-5.5 dBV	-5.5 dBV	-5.5 dBV	-2.5 dBV	-5.5 dBV

#### CS-YSS FULL BIT

3. CS-YSS F BIT

- The signal is output in digital full bit without including the head margin.

Reference data (PRE OUT)

INPUT: DVD ANALOG

SWFR: 50Hz, Others: 1kHz

Condition	MAIN L/R	CENTER	REAR C	SWFR	RL/RR
Both ch, -20 dBV, volume -10 dB	-5.5 dBV	+0.5 dBV	-3.0 dBV	-2.5 dBV	+6.5 dBV

DSP THROUGH ~  
CS-YSS (Analog)  
(Use of CS-YSS is not available due to restriction of the passage.)

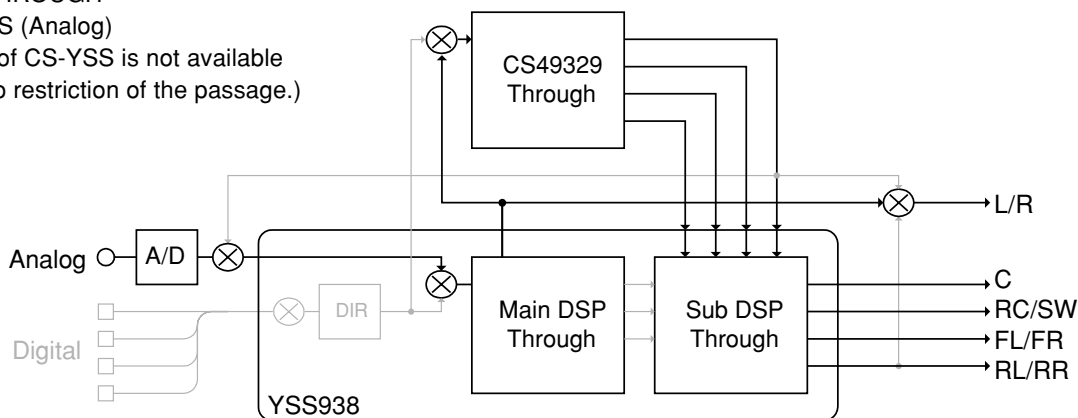

DSP THROUGH ~  
CS-YSS (AAC/dts (ES off))

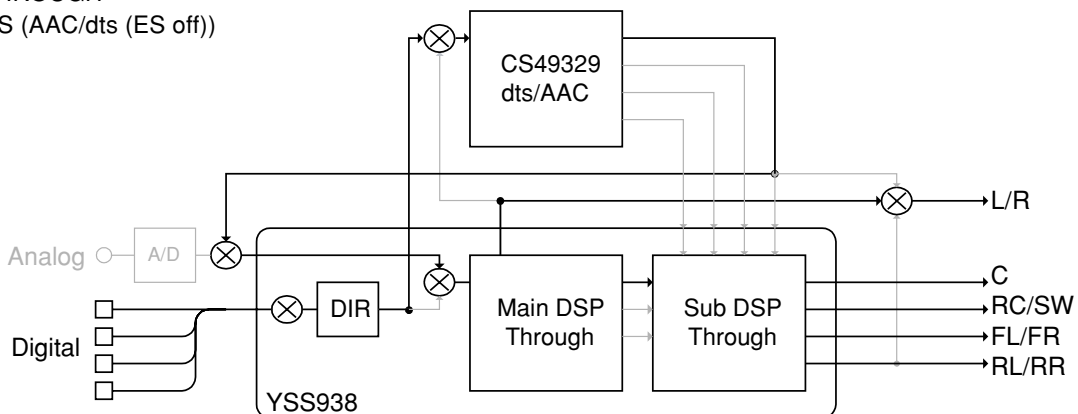



**4. CS49329**

8 channels are made usable by CS49329. The signal enters YSS938 through the Sub DSP passage and then undergoes through-output.

CS49329 is selected for the Main L/R output. Using the sub-menu, it is possible to select full bit output at 0dB output level.

\* As a 3dB margin of CS is always effective for RC when decoding dts ES, even when the output in full bit is specified, the RC output remains up to 0dBFS when 0dBFS is input to LS/RS.

**CS49329 0dB**

4. CS 0dB

- The signal is output including the head margin.  
Head margin:

Main L/R: -18dBFS, Center: -6dBFS, Rear Center: -3dBFS, FL/FR: -6dBFS, RL/RR: -18dBFS, SWFR: Add L/R signal at -20dBFS.

Reference data (PRE OUT)

INPUT: DVD ANALOG

SWFR: 50Hz, Others: 1kHz

Condition	MAIN L/R	CENTER	REAR C	SWFR	RL/RR
Both ch, -20 dBV, volume -10 dB	-5.5 dBV	-5.5 dBV	-5.5 dBV	-2.5 dBV	-5.5 dBV

**CS49329 FULL BIT**

4. CS FULL BIT

- The signal is output in digital full bit without including the head margin.

Reference data (PRE OUT)

INPUT: DVD ANALOG

SWFR: 50Hz, Others: 1kHz

Condition	MAIN L/R	CENTER	REAR C	SWFR	RL/RR
Both ch, -20 dBV, volume -10 dB	-5.5 dBV	+0.5 dBV	-3.0 dBV	-2.5 dBV	+6.5 dBV

DSP THROUGH ~

CS (Analog)

(Use of CS only is not available due to restriction of the passage.)

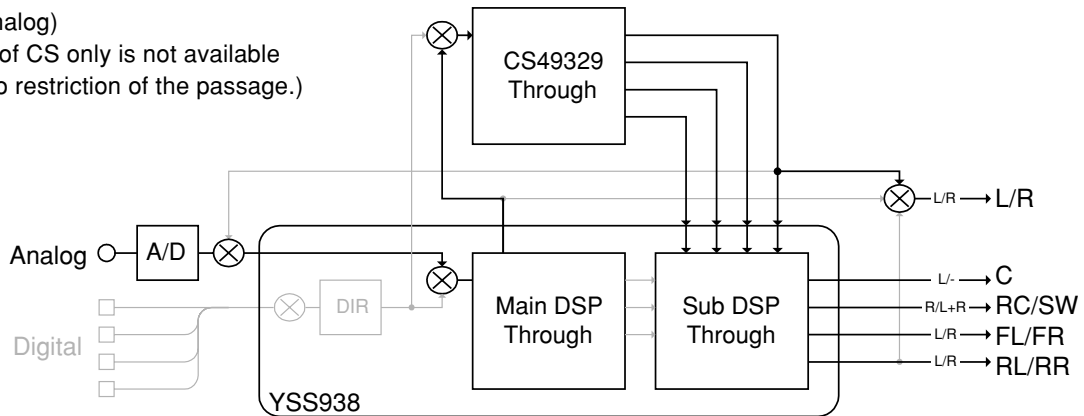

DSP THROUGH ~

CS (PCM)

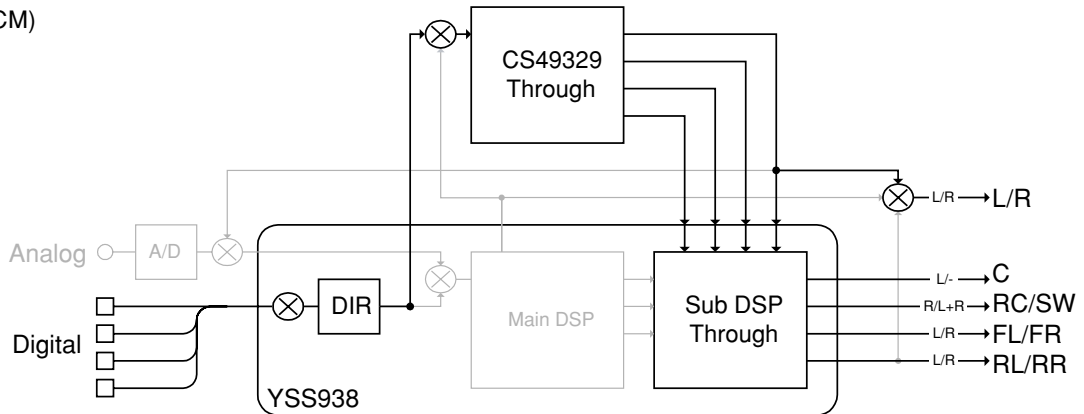

DSP THROUGH ~  
CS (AAC/dts (ES auto))

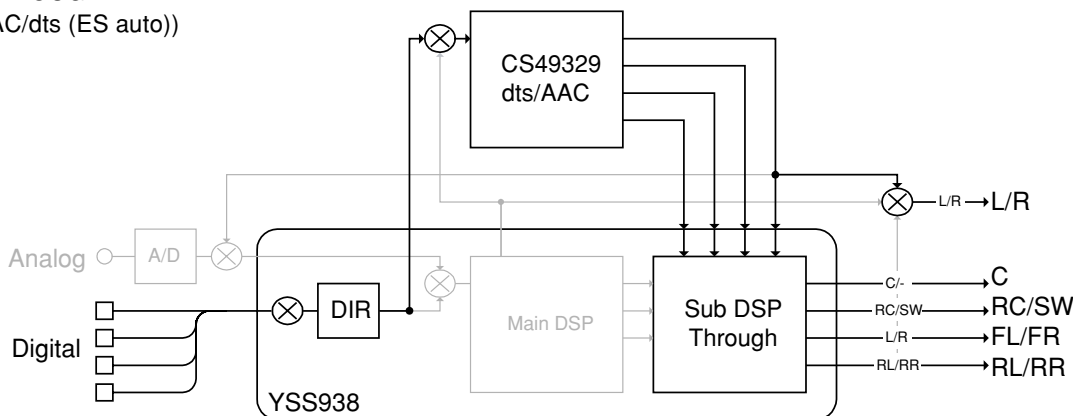

### 5. HP ROUTE

This function is for YSS938 only. Sub DSP SDOB3 of YSS938 is selected for MAIN L/R output. Using the sub-menu, it is possible to select the full-bit output at 0dB output level.

#### HP 0dB

5. HP 0dB

- The signal is output including the head margin.  
Head margin:  
Main L/R: -18dBFS, Center: -6dBFS, Rear Center: -3dBFS, FL/FR: -6dBFS, RL/RR: -18dBFS, SWFR: Add L/R signal at -20dBFS.

Reference data (PRE OUT)  
INPUT: DVD ANALOG  
SWFR: 50Hz, Others: 1kHz

Condition	MAIN L/R	CENTER	REAR C	SWFR	RL/RR
Both ch, -20 dBV, volume -10 dB	-5.5 dBV	-∞	-∞	-∞	-∞

#### HP FULL BIT

5. HP FULL BIT

- The signal is output in digital full bit without including the head margin.

Reference data (PRE OUT)  
INPUT: DVD ANALOG  
SWFR: 50Hz, Others: 1kHz

Condition	MAIN L/R	CENTER	REAR C	SWFR	RL/RR
Both ch, -20 dBV, volume -20 dB	+2.5 dBV	-∞	-∞	-∞	-∞

DSP THROUGH ~  
HP ROUTE (Auto)

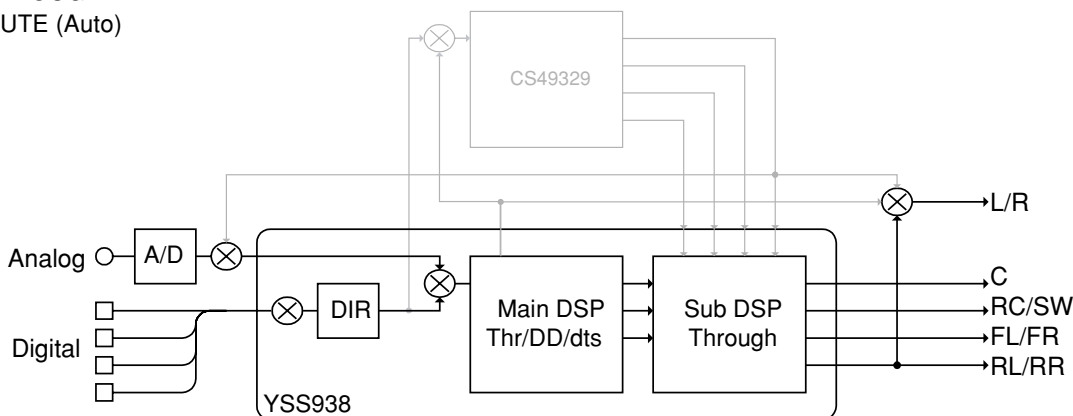

### 6. RAM THROUGH

This function is for YSS938 only. Main L/R signal is output through Main DSP of YSS938. CT/RC, RL/RR and FL/FR signals are output through Sub DSP - DRAM.

Using the sub-menu, it is possible to select the full-bit output at 0dB output level.

#### RAM 0dB

6. RAM 0dB

Reference data (PRE OUT)  
 INPUT: DVD ANALOG  
 SWFR: 50Hz, Others: 1kHz

Condition	MAIN L/R	CENTER	REAR C	SWFR	RL/RR
Both ch, -20 dBV, volume -10 dB	-5.5 dBV	-5.5 dBV	-5.5 dBV	-2.5 dBV	-5.5 dBV

#### MAIN ATT

6. MAIN ATT

- MAIN -9dB

Reference data (PRE OUT)  
 INPUT: DVD ANALOG  
 SWFR: 50Hz, Others: 1kHz

Condition	MAIN L/R	CENTER	REAR C	SWFR	RL/RR
Both ch, -20 dBV, volume -10 dB	-14.5 dBV	-5.5 dBV	-5.5 dBV	-2.5 dBV	-5.5 dBV

RAM THROUGH ~  
 (Auto)

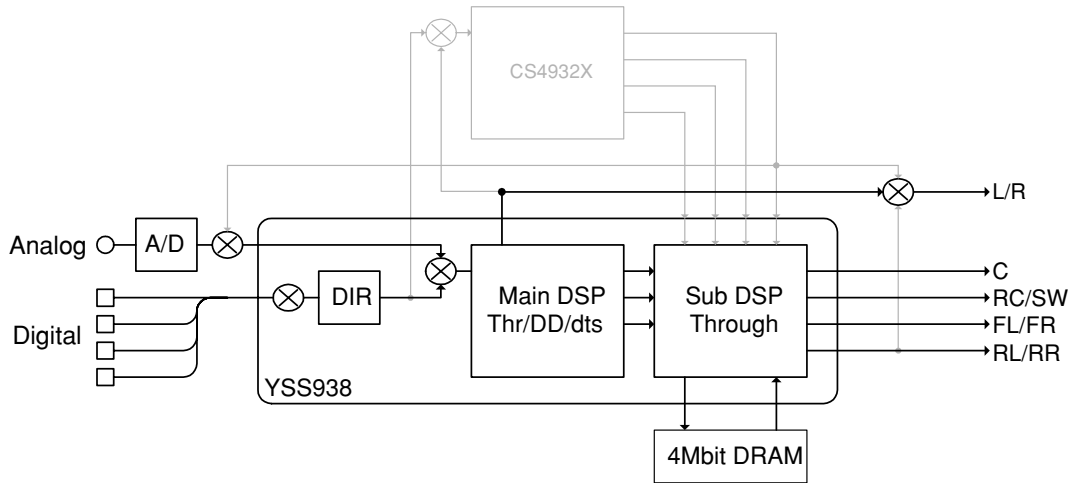

## 7. DOLBY PRO LOGIC [YSS938]

### PRO LOGIC I

#### 7. PRO LOGIC I

Reference data (PRE OUT)  
 INPUT: DVD ANALOG  
 SWFR: 50Hz, Others: 1kHz

Condition	MAIN L/R	CENTER	REAR C	SWFR	RL/RR
Each ch, -20 dBV, volume -10 dB	-5.5 dBV	-∞	-∞	-∞	-∞
Both ch, -20 dBV, volume -10 dB	-∞	-2.5 dBV	-∞	-∞	-∞
Both ch, -20 dBV (reverse phase), volume -10 dB	-∞	-∞	-∞	-∞	-5.5 dBV

### PRO LOGIC II

#### 7. PRO LOGIC II

Reference data (PRE OUT)  
 INPUT: DVD ANALOG  
 SWFR: 50Hz, Others: 1kHz

Condition	MAIN L/R	CENTER	REAR C	SWFR	RL/RR
Each ch, -20 dBV, volume -10 dB	-5.5 dBV	-∞	-∞	-∞	-∞
Both ch, -20 dBV, volume -10 dB	-∞	-2.5 dBV	-∞	-∞	-∞
Both ch, -20 dBV (reverse phase), volume -10 dB	-∞	-∞	-∞	-∞	-5.5 dBV

The L/C/R/RL/RR signals undergo the Pro-Logic processing and C/RL/RR signals are output through Sub DSP-DRAM. Main DSP is selected for MAIN L/R output.

Using the sub-menu, it is possible to select PRO LOGIC I, II (Movie). The Auto Input Balance function is always off. When dts/AAC input is used, the signal is decoded by CS49329 and the L/R signal undergoes the Pro-Logic processing. When the Dolby Digital Multi input is used, the function is the same as in the Dolby Digital Normal mode. The LFE signal is not output when decoding in the PRO LOGIC I, II mode.

Dolby Pro Logic (Auto)

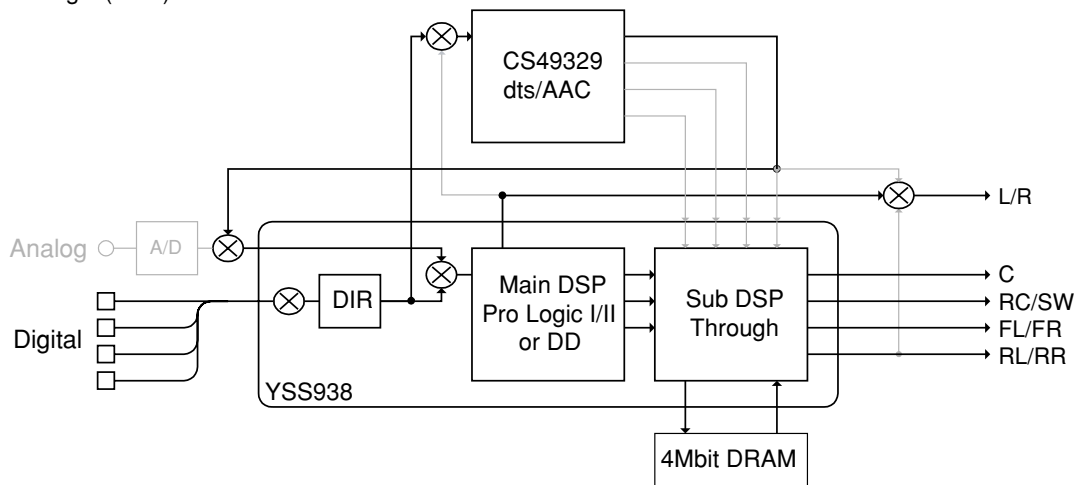

Neo:6

7. Neo:6

Reference data (PRE OUT)  
 INPUT: DVD ANALOG  
 SWFR: 50Hz, Others: 1kHz

Condition	MAIN L/R	CENTER	REAR C	SWFR	RL/RR
Each ch, -20 dBV, volume -10 dB	-5.5 dBV	-∞	-∞	-∞	-∞
Both ch, -20 dBV, volume -10 dB	-∞	-2.5 dBV	-∞	-∞	-∞
Both ch, -20 dBV (reverse phase), volume -10 dB	-∞	-∞	-∞	-∞	-5.5 dBV

L/C/R/RL/RC/RR signals are NEO:6 processed by CS49329 and C/RL/RC/RR signals are output through Sub DSP-DRAM. CS49329 is selected for the MAIN L/R output. The NEO:6 mode is fixed to Cinema 6ch.  
 When DD/dts input is used, the signal is decoded by YSS-938 and then L/R signal is NEO:6 processed by CS49329.  
 When AAC input is used, the signal is muted. When NEO:6 decoding is used, the LFE signal is not output.

NEO:6 (Auto)

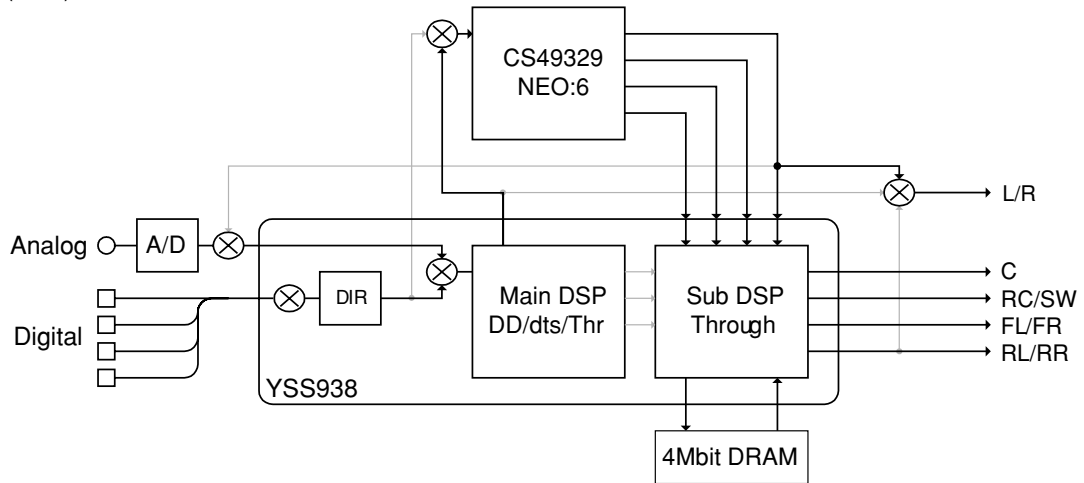

### 8. SPEAKERS SET

The input signal is automatically identified in the order of dts → DOLBY DIGITAL → AAC → PCM → Analog.

There are seven sub-menu items as follows. The signals output from the DSP block are the same as 1. YSS938: YSS 0dB.

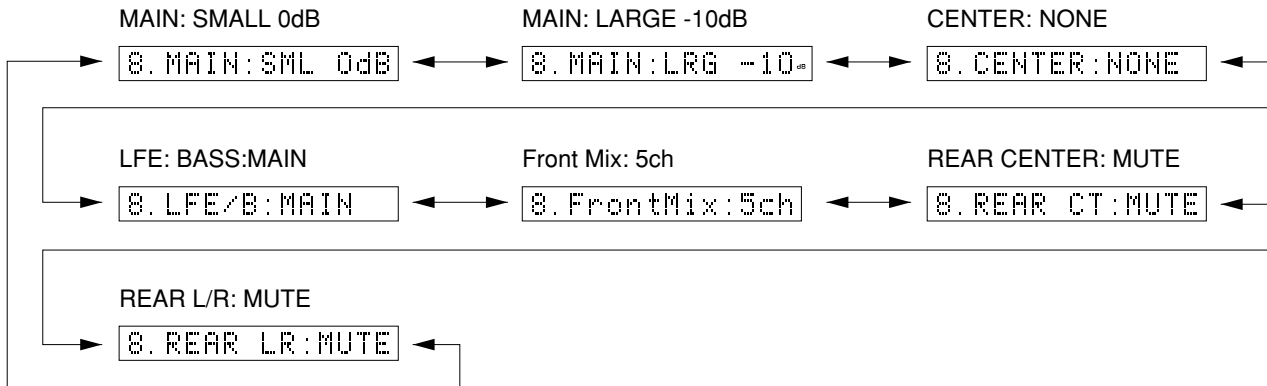

The analog switch settings for each sub-menu are as shown in the table below.

Sub-menu	CENTER SP	REAR SP	MAIN SP	MAIN LEVEL	LFE/BASS
1 MAIN: SMALL 0dB	LARGE	LARGE	SMALL	0dB	SWFR
2 MAIN: LARGE -10dB	LARGE	LARGE	LARGE	-10dB	BOTH
3 CENTER: NONE	NONE	LARGE	LARGE	0dB	BOTH
4 LFE/BASS: MAIN	SMALL	SMALL	LARGE	0dB	MAIN
5 FRONT MIX: 5CH	LARGE	LARGE	LARGE	0dB	BOTH
6 REAR CENTER: MUTE	LARGE	LARGE	LARGE	0dB	BOTH
7 REAR L/R: MUTE	LARGE	LARGE	LARGE	0dB	BOTH

**LARGE:** This mode is used with a speaker with high bass reproduction performance (a large unit). Full bandwidth signals are output.

**SMALL:** This mode is used with a speaker with low bass reproduction performance (a small unit). The signals of 90Hz or less are mixed into the channel specified by LFE/BASS.

**NONE:** This mode is used with no center speaker. The center content is reduced by 3dB and distributed to MAIN L/R.

Reference data (PRE OUT)  
 INPUT: DVD ANALOG (Both ch)  
 VOLUME: -10 dB

Sub-menu	Condition	MAIN L/R	CENTER	REAR C	SWFR	RL/RR
1 MAIN: SMALL 0dB	1kHz/90Hz, -20 dBV	-5.5/-8.5 dBV	-5.5 dBV	-5.5 dBV	-2.5 dBV	-5.5 dBV
2 MAIN: LARGE -10dB	1kHz, -20 dBV	-15.5 dBV	-5.5 dBV	-5.5 dBV	-2.5 dBV	-5.5 dBV
3 CENTER: NONE	1kHz, -20 dBV	-9.0 dBV	-∞	-5.5 dBV	-2.5 dBV	-5.5 dBV
4 LFE/BASS: MAIN	50Hz, -20 dBV	-4.0 dBV	-8.5 dBV (90Hz)	-5.5 dBV	-∞	-8.5 dBV (90Hz)
5 FRONT MIX: 5CH	1kHz, -20 dBV	-11.5 dBV	-5.5 dBV	-5.5 dBV	-2.5 dBV	-5.5 dBV
6 REAR CENTER: MUTE	1kHz, -20 dBV	-5.5 dBV	-5.5 dBV	-∞	-2.5 dBV	-5.5 dBV
7 REAR L/R: MUTE	1kHz, -20 dBV	-5.5 dBV	-5.5 dBV	-5.5 dBV	-2.5 dBV	-∞

### 9. DISPLAY CHECK

This program is used to check the FL display section. The display condition varies as shown below according to the sub-menu operation. The signals are processed using EFFECT OFF (The L/R signal is output using ANALOG MAIN BYPASS.)

The video signal internal/external synchronization switching is controlled by the microprocessor. When the initial message is displayed and all the FL segments light up, it is switched to the internal synchronization but other than that it is forced to the external synchronization setting.

Also, except for the initial display, 128 pictographs for checking the OSD driver are used for the video signal output display.

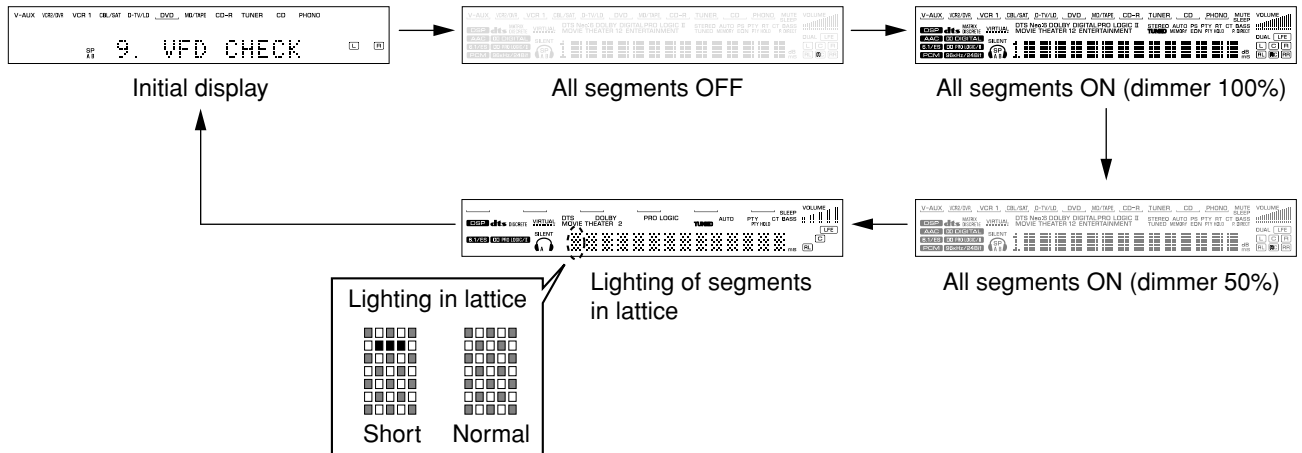

Segment conditions of the FL driver and the FL tube are checked by turning ON and OFF all segments. Next, the operation of the FL driver is checked by using the dimmer control. Then a short between segments next to each other is checked by turning ON and OFF all segments alternately (in lattice). (In the above example, the segments in the second row from the top are shorted.)

### 10. MANUAL TEST

The noise generator with a built-in DSP outputs the test noise through the channels specified by the sub-menu. The noise frequency for LFE is 35 to 250 Hz. Other than that, the center frequency is 800Hz.

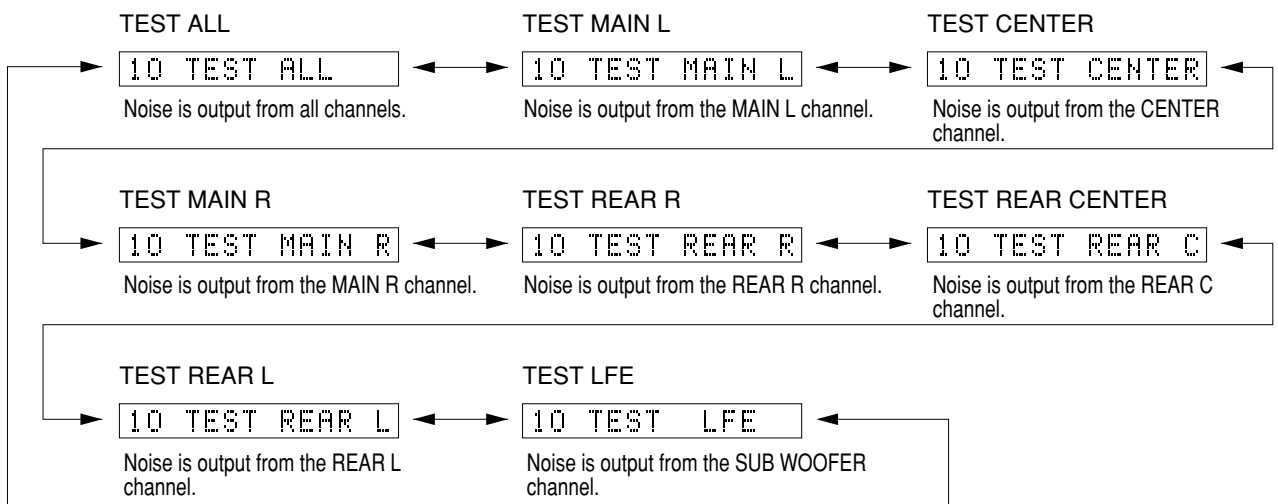

**11. RS-232C**

This menu is unused.

**12. FACTORY PRESET**

This menu is used to reserve and inhibit initialization of the back-up RAM. The signals are processed using EFFECT OFF. (The L/R signal is output using ANALOG MAIN BYPASS.)

12 PRESET INHI



12 PRESET RSRV

**PRESET INHIBIT** (Initialization inhibited)

RAM initialization is not executed. Select this sub-menu to protect the values set by the user.

**PRESET RESERVED** (Initialization reserved)

Initialization of the back-up RAM is reserved. (Actually, initialization is executed the next time that the power is turned on.) Select this sub-menu to reset to the original factory settings or to reset the RAM.

**CAUTION:** Before setting to the PRESET RESERVED, write down the existing preset memory content of the Tuner in a table as shown below. (This is because setting to the PRESET RESERVED will cause the user memory content to be erased.)

Preset group	P1	P2	P3	P4	P5	P6	P7	P8
A								
B								
C								
D								
E								

**• PRESET STATIONS**

STATION		FM FACTORY PRESET DATA (MHz)	
PAGE	NO.	U, C	R, T, K, A, B, G
A/C/E	1	87.5	87.5
	2	90.1	90.1
	3	95.1	95.1
	4	98.1	98.1
	5	107.9	108.0
	6	88.1	88.1
	7	106.1	106.1
	8	107.9	108.0

STATION		AM FACTORY PRESET DATA (kHz)	
PAGE	NO.	U, C, R, T, K	A, B, G
B/D	1	630	630
	2	1080	1080
	3	1440	1440
	4	530	531
	5	1710	1611
	6	900	900
	7	1350	1350
	8	1400	1404

**13. AD DATA CHECK/FAN TEST**

This menu is used to display the A/D conversion value of the main CPU which detects panel keys of the main unit and protection functions in % using the sub-menu. (Reference voltage 5V as 100%) During signal processing, the condition before execution is maintained.

When K0/K1 menu is selected, keys become non-operable due to detection of the values of all keys. However, it is possible to advance to the next sub-menu by turning the VOLUME of the main unit. When using this function, note that turning the VOLUME more than 1 click would cause the volume value to change.

\* The figures in the diagram are given as reference only.

**DC/PS** (protection detection)

DC:007 PS:025

DC: DC detect protection value (Normal value: 1 to 13)

PS: Power supply voltage protection value (Normal value: 21 to 31)

\* If DC or PS is out of the normal value range, the protection function works to turn off the power.



**THM/FAN OUT** (temperature detection/fan drive level)

THM:086 Fan\_/\_/\_

THM: 500% display of the voltage based on the temperature detected value. Reference voltage : 5V

(Normal value: U, C models ..... 51 to 169  
Others models ..... 41 to 151)

Fan: Current fan drive level on the left and the past fan drive history on the right.

**REC-OUT** (Select position)

REC-OUT:186

This applies to the model equipped with the REC OUT selector.

[Table 1]

Display	REC OUT Select
0+2	CD-R
15+2	CBL/SAT
30+2	PHONO
44+2	V-AUX
60+2	MD/TAPE
76+2	D-TV/LD
92+2	PHONO
122+2	TUNER
137+2	VCR1
153+2	CD
170+2	VCR2/DVR
186+2	SOURCE
202+2	DVD

**IMP SW/POWER LIMIT** (Impedance/power limiter detection)

IMP:8 PL:009

IMP: 8 or 4 ohm impedance switch setting

PL: Power limiter detection value

**K0/K1** (Panel key of main unit) [Remote control code: -]

K0:100 K1:100

A/D of the key fails to function properly when the standard value is deviated by  $\pm 4\%$ . In this case, check the constant of partial pressure resistor, solder condition, etc. Refer to table 2.

[Table 2]

Display	K0	K1
00+2	PRESET/TUNING ▷	-
10+2	◁ PRESET/TUNING	INPUT ▷
20+2	PRESET/TUNING	◁ INPUT
30+2	FM/AM	INPUT MODE
40+2	MEMORY	SPEAKERS A
50+2	TUNING MODE	SPEAKERS B
60+2	RDS MODE	EFFECT
70+2	RDS EON	PROGRAM ▷
80+2	PTY MODE	◁ PROGRAM
90+2	PTY START	A/B/C/D/E
100	KEY OFF	KEY OFF

**FAN DRIVE TEST** (For models so equipped)

FAN TEST:HIGH

HIGH

**FAN DRIVE TEST** (For models so equipped)

FAN TEST:MID

MID

**FAN DRIVE TEST** (For models so equipped)

FAN TEST:LOW

LOW

### 14. IF STATUS (Input function status)

Using the sub-menu, the status data is displayed one after another in the hexadecimal notation. During signal processing, the status before execution of this menu is maintained.

\* Numeric values in the figure example are for reference.

**IS1-3** (Internal status) • Indicates the status information of the microprocessor.

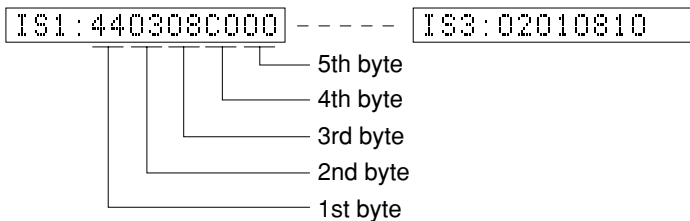

<1st byte> Digital input/output setting value  
Upper 4 bits: REC OUT selected/lower 4 bits: INPUT selected

Numeric value	Selection	Numeric value	Selection
0	NONE	4	OPT D (DVD)
1	OPT A (V-AUX)	6	OPT F (D-TV/LD)
2	OPT B (CD)	8	COAX A (CD)
3	OPT C (CD-R)	9	COAX B (CBL/SAT)

<2nd byte> Fs information of reproduction signal

Display	00	01	02	03	04	05	06	0A	0B	0C	0D
Fs (kHz)	Analog	32	44.1	48	64	88.2	96	Unknown NRM	Unknown DBL	Unknown QUAD	Not defined

<3rd byte> Audio code mode information of reproduction signal

Display	00	01	02	03	04	05	06	07	08	09	0A	0B	0C	0D
Audio Code	MULTI MONO	1+1	1/0	2/0	3/0	2/1	3/1	2/2	3/2	2/3	3/3	OVER 6.1	MULTI PCE	Unknown

<4th byte> Format information of reproduction signal

\*1: Analog processing used for digital reproduction is not possible because of a commercial bit or 4-ch audio reason.

Display	Signal format
00	Analog (Unlock)
01	Incorrect digital (*1)
10	PCM Audio
20	Digital Data
21	IEC1937 Data
22	None PCM
23	Unknown
50	dts
51	Red dts
54	dts-ES MATRIX
58	dts-ES DISCRETE
5C	dts-ES (Both flag)
60	AAC
C0	Dolby Digital
C1	D.D. Karaoke
C4	D.D.6.1 (D.D.EX)

<5th byte> Signal processing status information

\*2: With digital signals other than 32kHz, 44.1kHz and 48kHz, through processing method is used for reproducible signals.

bit7	MUTE request	bit3	–
bit6	Red dts flashing	bit2	Through & bypass (*2)
bit5	6.1ch. field being processed	bit1	–
bit4	FULL MUTE (ON: 1)	bit0	dts analog mute

**CS1-5:** Indicates channel status information of the input signal (IEC60958).

CS1:0299000200 - - - - - CS5:00000000

**BY1-4:** Indicates information of the bit stream included in the DOLBY DIGITAL signal.

BY1:1E40E1301B - - - - - BY4:01FFFFFF

**BC1-4:** Indicates information of the bit stream included in the dts signal.

BC1:000070FFFF - - - - - BC5:C4

**YS1-3:** Indicates device status information of YSS938 (IC514). \* The numeric value in the figure is an example for reference.

YS1:FEO2004F97

YS2:0101418000

YS3:1A41803D

Byte No.	Function
1	YSS MUTE Reg
2	YSS MODE Reg
3	YSS IPORT BIT 7-0
4	YSS IPORT BIT 14-8
5	YSS OPORT

Byte No.	Function
1	IEC 1937 Preamble Pc
2	Data Stream Reg
3	Status Reg
4	YSS ZERO Reg
5	MIREG

Byte No.	Function
1	DIR Status
2	DIR fs
3	DIR fs count
4	YSS ZEROBF

**CS:** CS49329 Unsolicited Messages (AUTODETECT\_RESPONSE)

CS :000001

**MTT:** Mute Trigger

MTT:0020000007

Byte No.	Function
1	Mute condition
2	Factor of the last mute
3	Error count of YSS938-FSCNT
4	Mute count by YSS938-FSCNT
5	Error factor of down load of CS49329

### 15. DSP RAM CHECK

This menu is used to self-diagnose whether or not the bus connection for the YSS938 and the external RAM is made properly.

During signal processing, the status before execution of this menu is maintained.

The address bus and the data bus are checked and the connection condition is displayed.

When no error is detected, "NoEr" appears on display.

**YSS938 Bus Check**

YSS Bus:NoEr

Display	Description
WAIT	Bus is being checked.
NoEr	No error detected.
DATA	Data bus shorted or open.
RSCS	/RAS or /CAS shorted, or open.
ADDR	Address bus shorted or open.

**PLD/SRAM BUS CHECK**

CS Bus:NoEr

Display	Description
WAIT	Bus is being checked.
NoEr	No error detected.
DATA	Data bus shorted or open. (XX: 00-07)
ADDR	Address bus shorted or open. (XX: 00-0E)

**16. CS DL CODE**

This menu is used to display the data version, TOC information and sum calculated value of the flash ROM for CS49329.

**ROM DATA VERSION:** Displays the data version of the Flash ROM for CS49329.

RDV:X

**TOC AREA 0-5:** Displays the TOC information.

TAO:0502629A ----- TAS:FFFFFFFF

**SUM CHECK AREA 0-5:** Displays the sum calculated value.

SAO:984E984E ----- SAS:FFFFFFFF

**17. SOFT SW**

This menu is used to switch the function settings on P.C.B. through the software so as to activate the product.

The protection function follows the P.C.B. settings. When connected to AC or in the maker preset state, the unit is initialized to the P.C. B. setting. Display of each function after initialization varies depending on settings on P.C.B. The operation mode can be changed by selecting the sub-menu and then using the EFFECT key. With SOF selected for the SW mode, the settings become effective.

**SW MODE:** PCB or SOFT can be selected.

17. SW :PCB

**MODEL SETTING:** V1200, V2200, V3200 or AX3200 can be selected.

17. MODEL:V1200

**TUNER DESTINATION:** J, UC, ATKG or R can be selected.

17. DEST :UC

**TUNER EXIST:** NOT or EXIST can be selected.

17. TUNER:EXIST

**RDS EXIST:** NOT or EXIST can be selected.

17. RDS :NOT

**ZONE 2 EXIST:** NOT or EXIST can be selected.

17. ZONE2:NOT

**VIDEO FORMAT:** NTSC or PAL can be selected.

17. VIDEO:NTSC

### 18. MICROPROCESSOR INFORMATION

The version, checksum and the port specified by the microprocessor are displayed. The signal is processed using EFFECT OFF. The checksum is obtained by adding the data at every 16 bits for each program area and expressing the result as a 4-figure hexadecimal data.

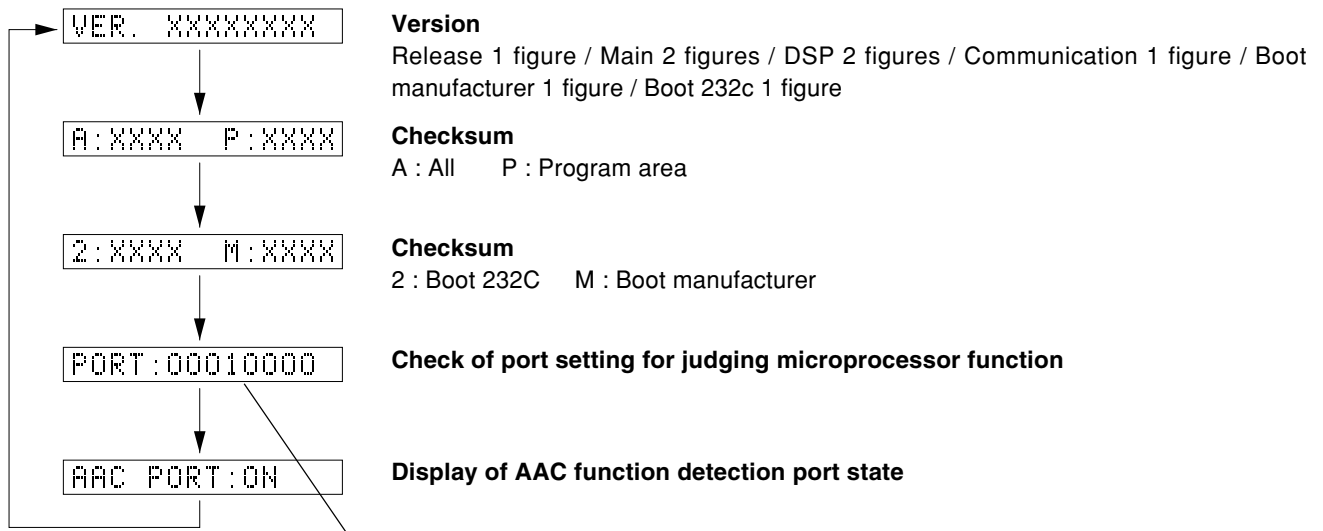

“PORT:0 0 0 0 0 0 0”  
bit 7 6 5 4 3 2 1 0

- Model type 0 (\*1)
- Model type 1 (\*1)
- Tuner mode 0 (\*2)
- Tuner mode 1 (\*2)
- Tuner with (1) / without (0)
- RDS with (1) / without (0)
- ZONE2 with (1) / without (0)
- VIDEO format: PAL (1) / NTSC (0)

\*1 (Model type)

Type 0	Type 1	Model type
0	0	V1200
1	0	V2200
0	1	V3200
1	1	AX3200

\*2 (Tuner mode)

Tuner mode 0	Tuner mode 1	Tuner frequency
0	0	AM: 531-1611kHz/9kHz FM: 76.0-90.0MHz/100kHz
0	1	AM: 531-1611kHz/9kHz FM: 87.5-108.0MHz/50kHz
1	0	AM: 530-1710kHz/10kHz FM: 87.5-107.9MHz/200kHz
1	1	R destination, Port6: LOW AM: 530-1710kHz/10kHz FM: 87.5-108.0MHz/100kHz HIGH AM: 531-1611kHz/9kHz FM: 87.5-108.0MHz/50kHz

### AMP ADJUSTMENT

#### Confirmation of Idling Current of Main (1) P. C. B.

- Right after power is turned on, confirm that the voltage across the terminals of R64 (Main Lch), R65 (Main Rch), R61 (Center), R59 (Rear Lch), R60 (Rear Rch), R126 (Rear Cch) are between 0.1mV and 10.0mV.
- If it exceeds 10.0mV, open (cutoff) R39 (Main Lch), R40 (Main Rch), R37 (Center), R34 (Rear Lch), R35 (Rear Rch), R117 (Rear Cch) and reconfirm the voltage.
- Confirm that the voltage is 0.20mV ~ 15.0mV after 60 minutes.

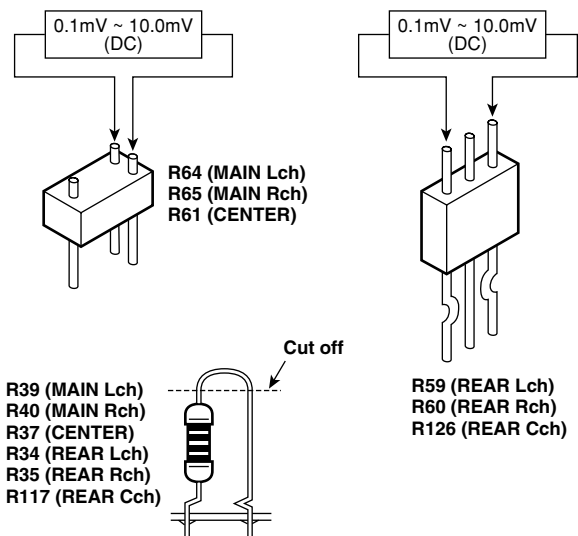

## ■ DISPLAY DATA

### ● V901 : 16-BT-91GK (V7683200)

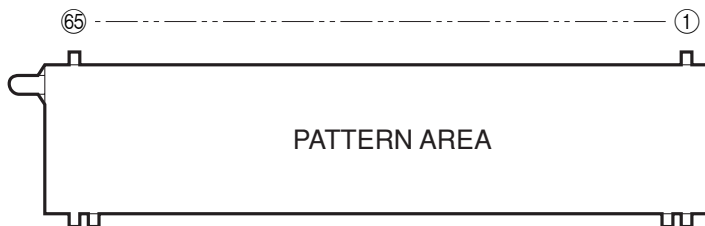

### ● PIN CONNECTION

Pin No.	65	64	63	62	61	60	59	58	57	56	55	54	53	52	51	50	49	48	47	46	45	44	43	42	41	40	39	38	37	36	35	34	33
Connection	F2	F2	NP	NP	P37	P36	P35	P34	P33	P32	P31	P30	P29	P28	P27	P26	P25	P24	P23	P22	P21	P20	P19	P18	P17	P16	P15	P14	P13	P12	P11	P10	P9

Pin No.	32	31	30	29	28	27	26	25	24	23	22	21	20	19	18	17	16	15	14	13	12	11	10	9	8	7	6	5	4	3	2	1
Connection	P8	P7	P6	P5	P4	P3	P2	P1	NC	NC	NC	NC	16G	15G	14G	13G	12G	11G	10G	9G	8G	7G	6G	5G	4G	3G	2G	1G	NP	NP	F1	F1

Note : 1) F1, F2 ..... Filament    2) NP ..... No pin    3) NC ..... No connection (NC pin should be electrically open on the PC board.)  
 4) DL ..... Datum Line    5) 1G ~ 16G ..... Grid    6) Field of vision is a minimum of 29° from the lower side.

### ● GRID ASSIGNMENT

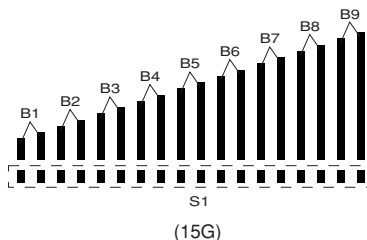
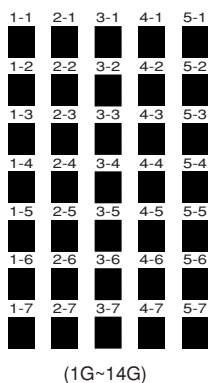
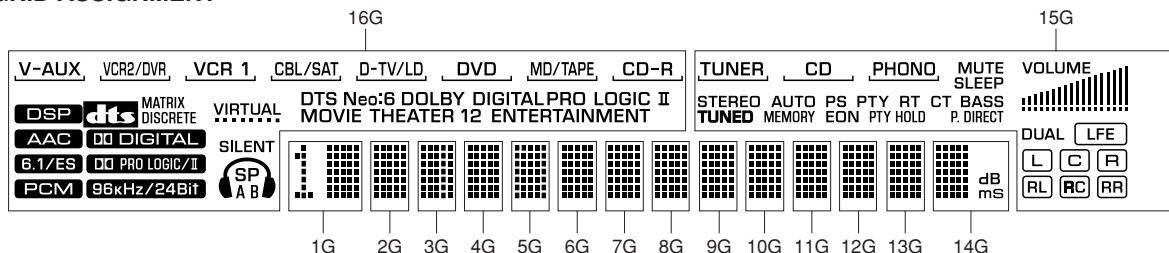

## ● ANODE CONNECTION

	16G	15G	14G	13G~2G	1G
P1	S2	S2	1-1	1-1	1-1
P2	<u>V-AUX</u>	<u>TUNER</u>	2-1	2-1	2-1
P3	<u>VCR2/DVR</u>	<u>CD</u>	3-1	3-1	3-1
P4	<u>VCR 1</u>	<u>PHONO</u>	4-1	4-1	4-1
P5	<u>CBL/SAT</u>	STEREO	5-1	5-1	5-1
P6	<u>D-TV/LD</u>	<b>TUNED</b>	1-2	1-2	1-2
P7	<u>DVD</u>	MEMORY	2-2	2-2	2-2
P8	<u>MD/TAPE</u>	AUTO	3-2	3-2	3-2
P9	<u>CD-R</u>	PS	4-2	4-2	4-2
P10	DTS	PTY	5-2	5-2	5-2
P11	Neo:6	RT	1-3	1-3	1-3
P12	DOLBY	CT	2-3	2-3	2-3
P13	DIGITAL	EON	3-3	3-3	3-3
P14	PRO LOGIC	PTY HOLD	4-3	4-3	4-3
P15	II	MUTE	5-3	5-3	5-3
P16	MOVIE THEATER	BASS	1-4	1-4	1-4
P17	1	P. DIRECT	2-4	2-4	2-4
P18	2	VOLUME	3-4	3-4	3-4
P19	ENTERTAINMENT	S1	4-4	4-4	4-4
P20	<b>DSP</b>	B1	5-4	5-4	5-4
P21	<b>AAC</b>	B2	1-5	1-5	1-5
P22	<b>6.1/ES</b>	B3	2-5	2-5	2-5
P23	<b>PCM</b>	B4	3-5	3-5	3-5
P24	<b>dtc</b>	B5	4-5	4-5	4-5
P25	MATRIX	B6	5-5	5-5	5-5
P26	DISCRETE	B7	1-6	1-6	1-6
P27	<b>DD DIGITAL</b>	B8	2-6	2-6	2-6
P28	<b>DD PRO LOGIC/II</b>	B9	3-6	3-6	3-6
P29	<b>96kHz/24Bit</b>	DUAL	4-6	4-6	4-6
P30	VIRTUAL .....	<b>LFE</b>	5-6	5-6	5-6
P31	SILENT	<b>L</b>	1-7	1-7	1-7
P32		<b>C</b>	2-7	2-7	2-7
P33	SP	<b>R</b>	3-7	3-7	3-7
P34	A	<b>RL</b>	4-7	4-7	4-7
P35	B	<b>RC</b>	5-7	5-7	5-7
P36	–	<b>RR</b>	dB	–	T1
P37	–	SLEEP	mS	–	–

IC DATA

IC514 : YSS938-F  
DSP

YSS938-F

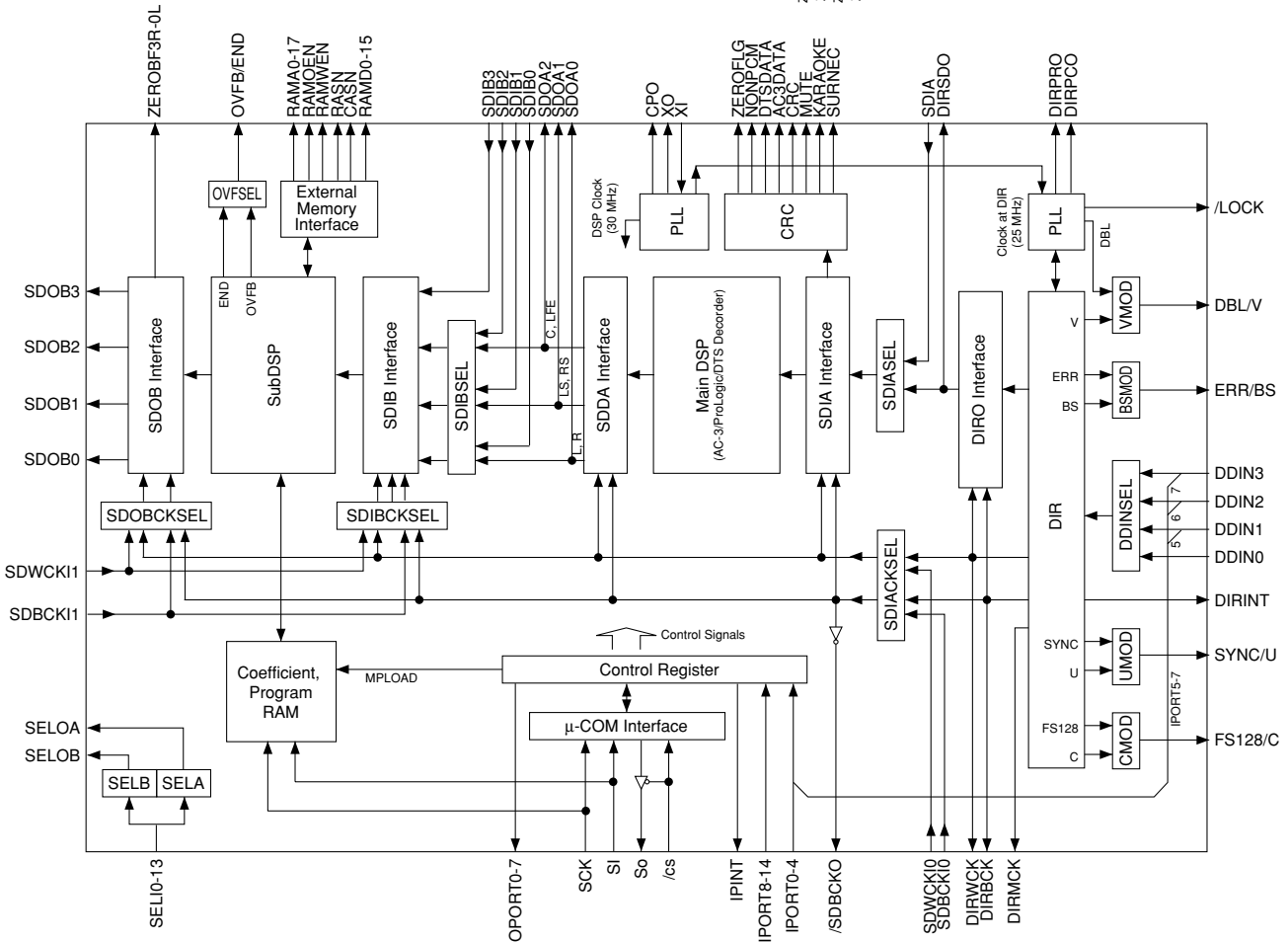
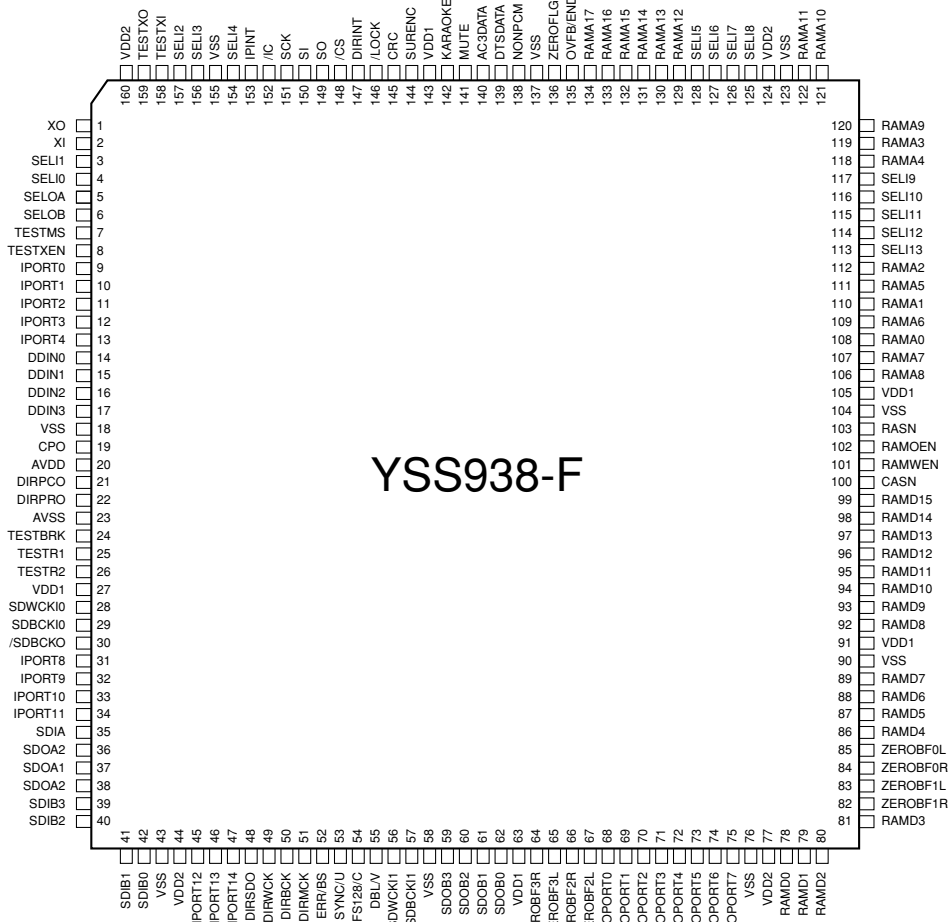



## IC514 : YSS938-F

## Pin Description

No.	Name	I/O	Function
1	XO	O	Crystal oscillator connecting terminal
2	XI	I	Crystal oscillator connecting terminal (24.576MHz )
3	SEL1	I+	Built-in selector input 1 (AXD)
4	SEL0	I+	Built-in selector input 0 (GND)
5	SELOA	O+	Built-in selector output A (ISEL)
6	SELOB	O+	Built-in selector output B (RSEL)
7	TESTMS	I+	Test terminal (unconnected)
8	TESTXEN	I+	Test terminal (unconnected)
9	IPORT0	I+	General purpose input terminal (CXDTA)
10	IPORT1	I+	General purpose input terminal (CXDTB)
11	IPORT2	I+	General purpose input terminal
12	IPORT3	I+	General purpose input terminal
13	IPORT4	I+	General purpose input terminal
14	DDIN0	Is	DIR: Digital audio interface data input terminal 0 (ISEL)
15	DDIN1	Is	DIR: Digital audio interface data input terminal 1/General purpose input terminal (Pull down)
16	DDIN2	Is	DIR: Digital audio interface data input terminal 2/General purpose input terminal (Pull down)
17	DDIN3	Is	DIR: Digital audio interface data input terminal 3/General purpose input terminal (Pull down)
18	VSS		Ground terminal
19	CPO	A	PLL filter connecting terminal
20	AVDD		+3.3V power terminal (for DIR)
21	DIRPCO	A	DIR: PLL filter connecting terminal
22	DIRPRO	A	DIR: PLL filter connecting terminal
23	AVSS		Ground terminal (for DIR)
24	TESTBRK	I+	Test terminal (unconnected)
25	TESTR1	I+	PLL initialization signal input terminal for DSP (/ICD)
26	TESTR2	I+	Test terminal (unconnected)
27	VDD1		+3.3V power terminal (for terminal section)
28	SDWCKI0	I+	Word clock input terminal for SDIA, SDOA, SDIB, SDOB interface (Unconnected)
29	SDBCKI0	I+	Bit clock input terminal for SDIA, SDOA, SDIB, SDOB interface (Unconnected)
30	/SDBCK0	O	DIRBCK or SDBCKI0 invert clock output terminal (Unconnected)
31	IPORT8	I+	IPINT general purpose input terminal
32	IPORT9	I+	IPINT general purpose input terminal
33	IPORT10	I+	IPINT general purpose input terminal (NONPCM)
34	IPORT11	I+	IPINT general purpose input terminal (NONPCM)
35	SDIA	I	AC-3/DTS bit stream (or PCM) data input terminal to Main DSP (SDIA)
36	SDOA2	O	PCM output terminal from Main DSP (C/LFE output) (Unconnected)
37	SDOA1	O	PCM output terminal from Main DSP (LS/RS output) (Unconnected)
38	SDOA0	O	PCM output terminal from Main DSP (L/R output)
39	SDIB3	I+	PCM input terminal 3 to Sub DSP
40	SDIB2	I+	PCM input terminal 2 to Sub DSP
41	SDIB1	I+	PCM input terminal 1 to Sub DSP
42	SDIB0	I+	PCM input terminal 0 to Sub DSP
43	VSS		Ground terminal
44	VDD2		+2.5V power terminal (for internal circuit)
45	IPORT12	I+	IPINT general purpose input terminal (MUTE)
46	IPORT13	I+	IPINT general purpose input terminal (DIRINT)
47	IPORT14	I+	IPINT general purpose input terminal (Unconnected)
48	DIRSDO	O	AC-3/DTS bit stream (or PCM) data output terminal from DIR
49	DIRWCK	O	DIR: Serial data word clock (fs) output terminal (WCK)
50	DIRBCK	O	DIR: Serial data bit clock (64fs) output terminal (BCK)
51	DIRMCK	O	DIR: Serial data master clock (256fs or 128fs) output terminal (MCK)
52	ERR/BS	O	DIR: Data error detect output/block start output terminal (Unconnected)
53	SYNC/U	O	DIR: Serial data synchronous timing output/user data output terminal (Unconnected)
54	FS128/C	O	DIR: Serial data master clock 128fs output/channel status output terminal (Unconnected)
55	DBL/V	O	DIR: Double rate clock output/validity flag output terminal (DBL)

No.	Name	I/O	Function
56	SDWCK11	I+	Word clock input terminal for SDIB, SDOB interface (Unconnected)
57	SDBCK11	I+	Bit clock input terminal for SDIB, SDOB interface (Unconnected)
58	VSS		Ground terminal
59	SDOB3	O	PCM output terminal from Sub DSP
60	SDOB2	O	PCM output terminal from Sub DSP
61	SDOB1	O	PCM output terminal from Sub DSP
62	SDOB0	O	PCM output terminal from Sub DSP
63	VDD1		+3.3V power terminal (for terminal section)
64	ZEROBF3R	O+	SDOB3 Rch zero flag output terminal (ZF3R)
65	ZEROBF3L	O+	SDOB3 Lch zero flag output terminal (ZF3L)
66	ZEROBF2R	O+	SDOB2 Rch zero flag output terminal (ZF2R)
67	ZEROBF2L	O+	SDOB2 Lch zero flag output terminal (ZF2L)
68	OPORT0	O	General purpose output terminal (/RINH1)
69	OPORT1	O	General purpose output terminal (/RINH2)
70	OPORT2	O	General purpose output terminal (/ICCDC)
71	OPORT3	O	General purpose output terminal (DFS)
72	OPORT4	O	General purpose output terminal (ZSEL0)
73	OPORT5	O	General purpose output terminal (ZSEL1)
74	OPORT6	O	General purpose output terminal (/ICCS)
75	OPORT7	O	General purpose output terminal
76	VSS		Ground terminal
77	VDD2		+2.5V power terminal (for internal circuit)
78	RAMD0	I+/O	Sub DSP: External memory data terminal 0
79	RAMD1	I+/O	Sub DSP: External memory data terminal 1
80	RAMD2	I+/O	Sub DSP: External memory data terminal 2
81	RAMD3	I+/O	Sub DSP: External memory data terminal 3
82	ZEROBF1R	O+	SDOB1 Rch zero flag output terminal (ZF1R)
83	ZEROBF1L	O+	SDOB1 Lch zero flag output terminal (ZF1L)
84	ZEROBF0R	O+	SDOB0 Rch zero flag output terminal (ZF0R)
85	ZEROBF0L	O+	SDOB0 Lch zero flag output terminal (ZF0L)
86	RAMD4	I+/O	Sub DSP: External memory data terminal 4
87	RAMD5	I+/O	Sub DSP: External memory data terminal 5
88	RAMD6	I+/O	Sub DSP: External memory data terminal 6
89	RAMD7	I+/O	Sub DSP: External memory data terminal 7
90	VSS		Ground terminal
91	VDD1		+3.3V power terminal (for terminal section)
92	RAMD8	I+/O	Sub DSP: External memory data terminal 8
93	RAMD9	I+/O	Sub DSP: External memory data terminal 9
94	RAMD10	I+/O	Sub DSP: External memory data terminal 10
95	RAMD11	I+/O	Sub DSP: External memory data terminal 11
96	RAMD12	I+/O	Sub DSP: External memory data terminal 12
97	RAMD13	I+/O	Sub DSP: External memory data terminal 13
98	RAMD14	I+/O	Sub DSP: External memory data terminal 14
99	RAMD15	I+/O	Sub DSP: External memory data terminal 15
100	CASN	O	Sub DSP: Column address strobe output terminal for external DRAM
101	RAMWEN	O	Sub DSP: Write enable terminal for external memory
102	RAMOEN	O	Sub DSP: Output enable terminal for external memory
103	RASN	O	Sub DSP: Low address strobe output terminal for external DRAM
104	VSS		Ground terminal
105	VDD1		+3.3V power terminal (for terminal section)
106	RAMA8	O	Sub DSP: External memory address terminal 8
107	RAMA7	O	Sub DSP: External memory address terminal 7
108	RAMA0	O	Sub DSP: External memory address terminal 0
109	RAMA6	O	Sub DSP: External memory address terminal 6
110	RAMA1	O	Sub DSP: External memory address terminal 1

No.	Name	I/O	Function
111	RAMA5	O	Sub DSP: External memory address terminal 5
112	RAMA2	O	Sub DSP: External memory address terminal 2
113	SELI13	I+	Built-in selector input 13 (Unconnected)
114	SELI12	I+	Built-in selector input 12
115	SELI11	I+	Built-in selector input 11 (Unconnected)
116	SELI10	I+	Built-in selector input 10 (Unconnected)
117	SELI9	I+	Built-in selector input 9
118	RAMA4	O	Sub DSP: External memory address terminal 4
119	RAMA3	O	Sub DSP: External memory address terminal 3
120	RAMA9	O	Sub DSP: External memory address terminal 9 (Unconnected)
121	RAMA10	O	Sub DSP: External memory address terminal 10 (Unconnected)
122	RAMA11	O	Sub DSP: External memory address terminal 11 (Unconnected)
123	VSS		Ground terminal
124	VDD2		+2.5V power terminal (for internal circuit)
125	SELI8	I+	Built-in selector input 8 (CXA)
126	SELI7	I+	Built-in selector input 7 (GND)
127	SELI6	I+	Built-in selector input 6 (OPTF)
128	SELI5	I+	Built-in selector input 5 (Unconnected)
129	RAMA12	O	Sub DSP: External memory address terminal 12 (Unconnected)
130	RAMA13	O	Sub DSP: External memory address terminal 13 (Unconnected)
131	RAMA14	O	Sub DSP: External memory address terminal 14 (Unconnected)
132	RAMA15	O	Sub DSP: External memory address terminal 15 (Unconnected)
133	RAMA16	O	Sub DSP: External memory address terminal 16 (Unconnected)
134	RAMA17	O	Sub DSP: External memory address terminal 17 (Unconnected)
135	OVFB/END	O	Sub DSP: Overflow/program end detect terminal (Unconnected)
136	ZEROFLG	O	Main DSP: Zero flag output terminal (Unconnected)
137	VSS		Ground terminal
138	NONPCM	O	Main DSP: Non-PCM data detect terminal
139	DTSDATA	O	Main DSP: DTS data detect terminal (Unconnected)
140	AC3DATA	O	Main DSP: AC3 data detect terminal (Unconnected)
141	MUTE	O	Main DSP: Auto mute detect terminal
142	KARAOKE	O	Main DSP: AC3 KARAOKE data detect terminal (Unconnected)
143	VDD1	+3.3V	power terminal (for terminal section)
144	SURENC	O	Main DSP: AC-3 2/0 mode Dolby surround encode input detect terminal (Unconnected)
145	CRC	O	Main DSP: AC3 CRC error detect terminal (Unconnected)
146	/LOCK	O	DIR: PLL lock detect terminal (Unconnected)
147	DIRINT	O	DIR: Interrupt output terminal
148	/CS	Is	Microprocessor interface chip select input terminal (CSY)
149	SO	Ot	Microprocessor interface data output terminal
150	SI	Is	Microprocessor interface data input terminal (SDM)
151	SCK	Is	Microprocessor interface clock input terminal (SCKY)
152	/IC	Is	Initial clear input terminal (/ICD)
153	IPINT	O+	Interrupt output terminal by IPORT 8-14
154	SELI4	I+	Built-in selector input 4 (OPTD)
155	VSS		Ground terminal
156	SELI3	I+	Built-in selector input 3 (OPTC)
157	SELI2	I+	Built-in selector input 2 (OPTB)
158	TESTXI	I	Test terminal (should be always connected to VSS)
159	TESTXO	O	Test terminal (Unconnected)
160	VDD2	+2.5V	power terminal (for internal circuit)

Is: Schmidt trigger input terminal  
I+: Input terminal with pull-up resistor  
O: Digital output terminal  
Ot: 3-state digital output terminal  
A: Analog terminal

IC520 : M30802SGP  
16bit μ-COM (Main CPU)

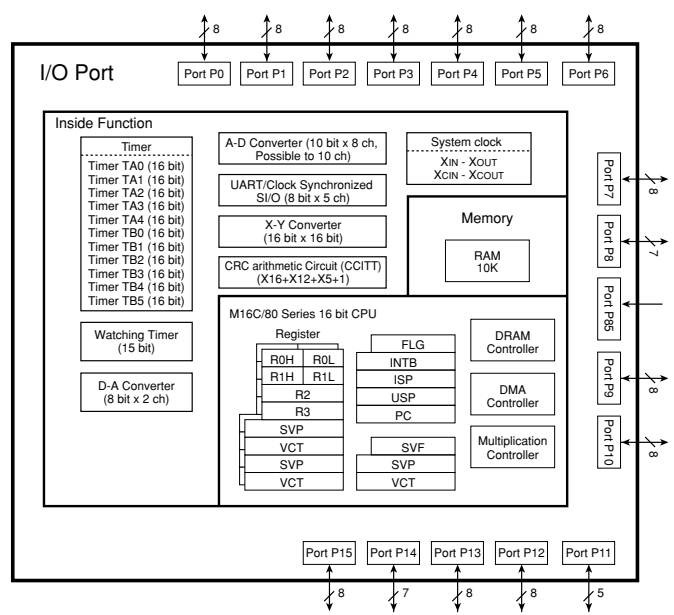
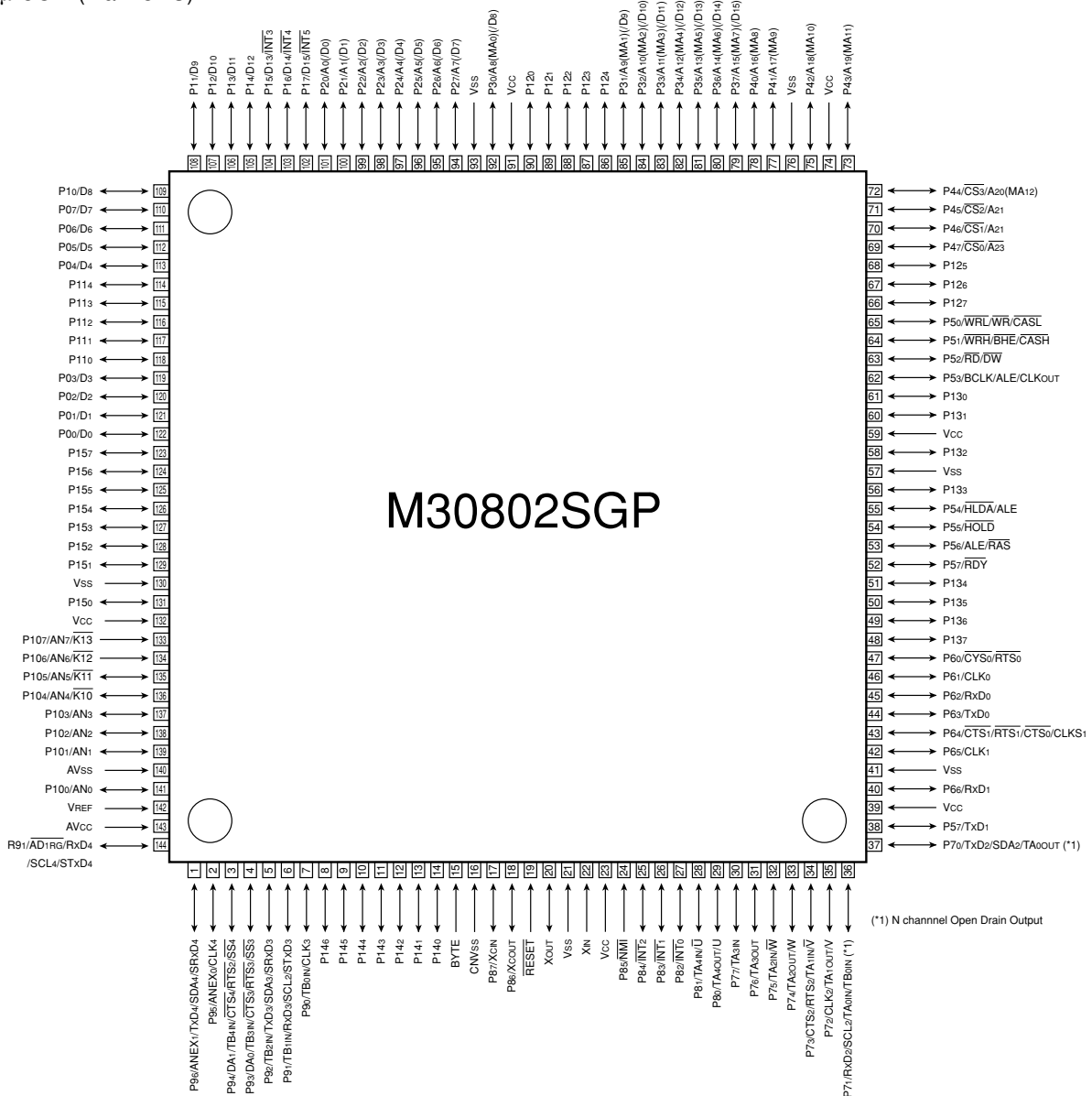

## IC520 : M30802SGP

## Pin Description

No.	Port No.	Function name	I/O	Detail of function	Power ON	Power OFF	Backup
1	P96	TXDR	SO	232C TX DATA / YDC TX DATA	O	OL	OL
2	P95	RTS	SCK	232C RTS / YDC CLOCK	I/O	OL	OL
3	P94	CTS	I	232C CTS	I	I	OL
4	P93	FAN	DA/O	FAN CONTROL	I	I	OL
5	P92	SDTN	SO	NON AUDIO TX DATA	SO	OL	OL
6	P91	RXRDS	SI	RDS RX DATA / FREQ SW (R VER)	SI	I	OL
7	P90	SCKN	SCK	NON AUDIO SERIAL CLOCK	SCK	OL	OL
8	P146		O		O	OL	OL
9	P145	CEBU	O/I (PU)	BU2092 CE / ZONE2 FUNCTION	I/O	I/OL	OL
10	P144	/FLR	O	FL IC RESET	O	OL	OL
11	P143	CEM0	I/O	FL1 CE / MODEL DETECT 0	I/O	I/OL	OL
12	P142	CEM1	I	MODEL DETECT 1	I	I	OL
13	P141	RDSE	O/I (PU)	RDS CE / RDS FUNCTION	I/O	I/OL	OL
14	P140	CES	O/I (PU)	OSD CE / NTSC / PAL FORMAT	I/O	I/OL	OL
15	BYTE	BYTE	VSS	16 BIT DATA BUS: Vss	Vss	Vss	Vss
16	CNVss	CNVss	VCC		Vcc	Vcc	Vcc
17	P87	BT232C	I (PU)	232C BOOT SIG. / 6CH INPUT KEY	I	I	OL
18	P86	BTYDC	I	YDC BOOT SIGNAL	I	I	OL
19	RESET	RESET	I	RESET	-	-	-
20	XOUT	XOUT	OPEN	CLOCK OUT	-	-	-
21	VSS	VSS	VSS	GROUND	-	-	-
22	XIN	XIN	12MHz	CLOCK IN	-	-	-
23	VCC	VCC	VCC	+5V	-	-	-
24	P85	NMI		Un-use	-	-	-
25	P84	REM1	INT (LoEdge)	REMOTE CONTROL PULSE	I	I	OL
26	P83	PSW	INT (LoEdge)	POWER SW	I	I	OL
27	P82	PDET	INT (LoEdge)	POWER DETECT	I	I	I
28	P81	VSX	Lo Edge	VERTICAL SYNC PULSE	I	I	OL
29	P80	/ICD	O	IC DSP IC	O	OL	OL
30	P77	RXDR	Double Edge	232C RX DATA	I	I	OL
31	P76	DMT	O	DIGITAL FULL MUTE	O	OL	OL
32	P75	INT938	Lo Edge	YSS938 IPINT	I	I	OL
33	P74	DMTR	O	DIGITAL FULL MUTE REAR L/R	O	OL	OL
34	P73	CEP	I/O	PLL IC CE / TUNER STEP 1	I/O	I/OL	OL
35	P72	SCKP	I/O	PLL IC CLOCK / TUNER STEP 0	I/O	I/OL	OL
36	P71	RDTP	ASI	PLL IC RX DATA	I	I	OL
37	P70	SDTP	I/ASO	PLL IC TX DATA (PU) / TUNER	I/O	OL	OL
38	P67	SDM	SO	DSP IC TX DATA	SO	OL	OL
39	VCC	VCC	VCC	+5V			
40	P66	SDD	SI	DSP IC RX DATA	SI	I	OL
41	VSS	VSS	VSS	GND			
42	P65	SCK	SCK	DSP IC CLOCK	SCK	OL	OL
43	P64	/CSY	I/O	YSS938 CE	I/O	OL	OL
44	P63	CTEV	O	EVOL TX DATA	SO	OL	OL
45	P62	CEEV	O	EVOL CE	O	OL	OL
46	P61	CKEV	SCK	EVOL CLOCK	SCK	OL	OL
47	P60	/CSCS	I/O	CS493X CS	I/O	OL	OL
48	P137	/CSPLD	O	DIGITAL EXT. CONTROL IC CE	O	OL	OL
49	P136	VRB	I	VOLUME ROTARY B	I	I	OL
50	P135	VRA	I	VOLUME ROTARY A	I	I	OL
51	P134	PRI	I	I PROTECTION	I	I	I
52	P57						HI
53	P56		OPEN				HI
54	P55		Vcc				HI
55	P54			OPEN			HI
56	P133	/BEC	O	BASS EXTENTION CONTROL	O	OL	OL
57	VSS	VSS	VSS	GND			
58	P132	/Z2MT	O	ZONE 2 MUTE	O	OL	OL
59	VCC	VCC	VCC	+5V			
60	P131	/HPMT	O	HEADPHONE MUTE	O	OL	OL
61	P130	/MATT	O	MAIN -3dB	O	OL	OL
62	P53		OPEN				HI
63	P52			OE			HI
64	P51						HI
65	P50			WE			HI
66	P127	/FMST	O	FULL MUTE SWL / SWR / SW MONO	O	OL	OL
67	P126	/FMTC	O	FULL MUTE CENTER	O	OL	OL
68	P125	/FMTR	O	FULL MUTE MAIN L / R, RL / RC / RR	O	OL	OL
69	P47			EXT. ROM ADDRESS BUS			KEEP
70	P46		OPEN	EXT. ROM ADDRESS BUS			KEEP
71	P45		OPEN	EXT. ROM ADDRESS BUS			KEEP
72	P44		OPEN	EXT. ROM ADDRESS BUS			KEEP
73	P43		OPEN	EXT. ROM ADDRESS BUS			KEEP
74	VCC	VCC	VCC	+5V			
75	P42		OPEN	EXT. ROM ADDRESS BUS			KEEP

No.	Port No.	Function name	I/O	Detail of function	Power ON	Power OFF	Backup
76	VSS	VSS	VSS	GND			
77	P41	A17		EXT. ROM ADDRESS BUS			KEEP
78	P40	A16		EXT. ROM ADDRESS BUS			KEEP
79	P37	A15		EXT. ROM ADDRESS BUS			KEEP
80	P36	A14		EXT. ROM ADDRESS BUS			KEEP
81	P35	A13		EXT. ROM ADDRESS BUS			KEEP
82	P34	A12		EXT. ROM ADDRESS BUS			KEEP
83	P33	A11		EXT. ROM ADDRESS BUS			KEEP
84	P32	A10		EXT. ROM ADDRESS BUS			KEEP
85	P31	A9		EXT. ROM ADDRESS BUS			KEEP
86	P124	SCKA	SCK	AUDIO IC CLOCK	O	OL	OL
87	P123	SDTA	SO	AUDIO IC TX DATA	O	OL	OL
88	P122	CEL	O	SANYO IC CE	O	OL	OL
89	P121	RIMA	O	POWER LIMITER A	O	OL	OL
90	P120	RIMB	O	POWER LIMITER B	O	OL	OL
91	VCC	VCC	VCC	+5V			
92	P30	A8		EXT. ROM ADDRESS BUS			KEEP
93	VSS	VSS	VSS	GND			
94	P27	A7		EXT. ROM ADDRESS BUS			KEEP
95	P26	A6		EXT. ROM ADDRESS BUS			KEEP
96	P25	A5		EXT. ROM ADDRESS BUS			KEEP
97	P24	A4		EXT. ROM ADDRESS BUS			KEEP
98	P23	A3		EXT. ROM ADDRESS BUS			KEEP
99	P22	A2		EXT. ROM ADDRESS BUS			KEEP
100	P21	A1		EXT. ROM ADDRESS BUS			KEEP
101	P20	A0		EXT. ROM ADDRESS BUS			KEEP
102	P17	D15		EXT. ROM DATA BUS			KEEP
103	P16	D14		EXT. ROM DATA BUS			KEEP
104	P15	D13		EXT. ROM DATA BUS			KEEP
105	P14	D12		EXT. ROM DATA BUS			KEEP
106	P13	D11		EXT. ROM DATA BUS			KEEP
107	P12	D10		EXT. ROM DATA BUS			KEEP
108	P11	D9		EXT. ROM DATA BUS			KEEP
109	P10	D8		EXT. ROM DATA BUS			KEEP
110	P07	D7		EXT. ROM DATA BUS			KEEP
111	P06	D6		EXT. ROM DATA BUS			KEEP
112	P05	D5		EXT. ROM DATA BUS			KEEP
113	P04	D4		EXT. ROM DATA BUS			KEEP
114	P114	/MLV	O	MAIN LEVEL	O	OL	OL
115	P113	PRY	O	POWER RELAY	O	OL	OL
116	P112	SPE	O	SP RELAY EFFECT	O	OL	OL
117	P111	SPB	O	SP RELAY B	O	OL	OL
118	P110	SPA	O	SP RELAY A	O	OL	OL
119	P03	D3		EXT. ROM DATA BUS			KEEP
120	P02	D2		EXT. ROM DATA BUS			KEEP
121	P01	D1		EXT. ROM DATA BUS			KEEP
122	P00	D0		EXT. ROM DATA BUS			KEEP
123	P157	DCTRIG	O	DC TRIGGER CONTROL	O	OL	OL
124	P156	CSINT	I(IPU)/O	CS-DSP INT / ABOOT	I/O	OL	OL
125	P155	BSW	I(IPU)	BASS EXT SW	I	I	OL
126	P154	PSW	I(IPU)	PR. DIRECT SW	I	I	OL
127	P153	/HP	I(IPU)	HEADPHONE DETECT	I	I	OL
128	P152	TMT	O	TUNER MUTE	O	OL	OL
129	P151	/TUNED	I(IPU)	TUNING METER	I	I	OL
130	VSS	VSS	VSS	GND			
131	P150	/ST	I(IPU)	TUNER STEREO	I	I	OL
132	VCC	VCC	VCC	+5V			
133	P107	RMV	AD	Un-use (DETECT PL TYPE)	I	I	I
134	P106	REC	AD	REC OUT SELECTOR	I	I	I
135	P105	PREMT	AD	POWER LIMITER DETECT	I	I	I
136	P104	ADKEY1	AD	KEY SW LINE 1	I	I	I
137	P103	ADKEY0	AD	KEY SW LINE 0	I	I	I
138	P102	THM	AD	TEMPERATURE DETECTION	I	I	I
139	P101	PRD	AD	DC PROTECTION	I	I	I
140	AVSS	AVSS	VSS	AD GND	VSS	VSS	VSS
141	P100	PRV	AD	PS PROTECTION	I	I	I
142	VREF	VREF	VCC	AD REFERENCE	VCC	VCC	VCC
143	AVCC	AVCC	VCC	AD V	VCC	VCC	VCC
144	P97	RXDR	SI	232C / YDC RX DATA	I	I	OL

1 ■ BLOCK DIAGRAM (1/2)

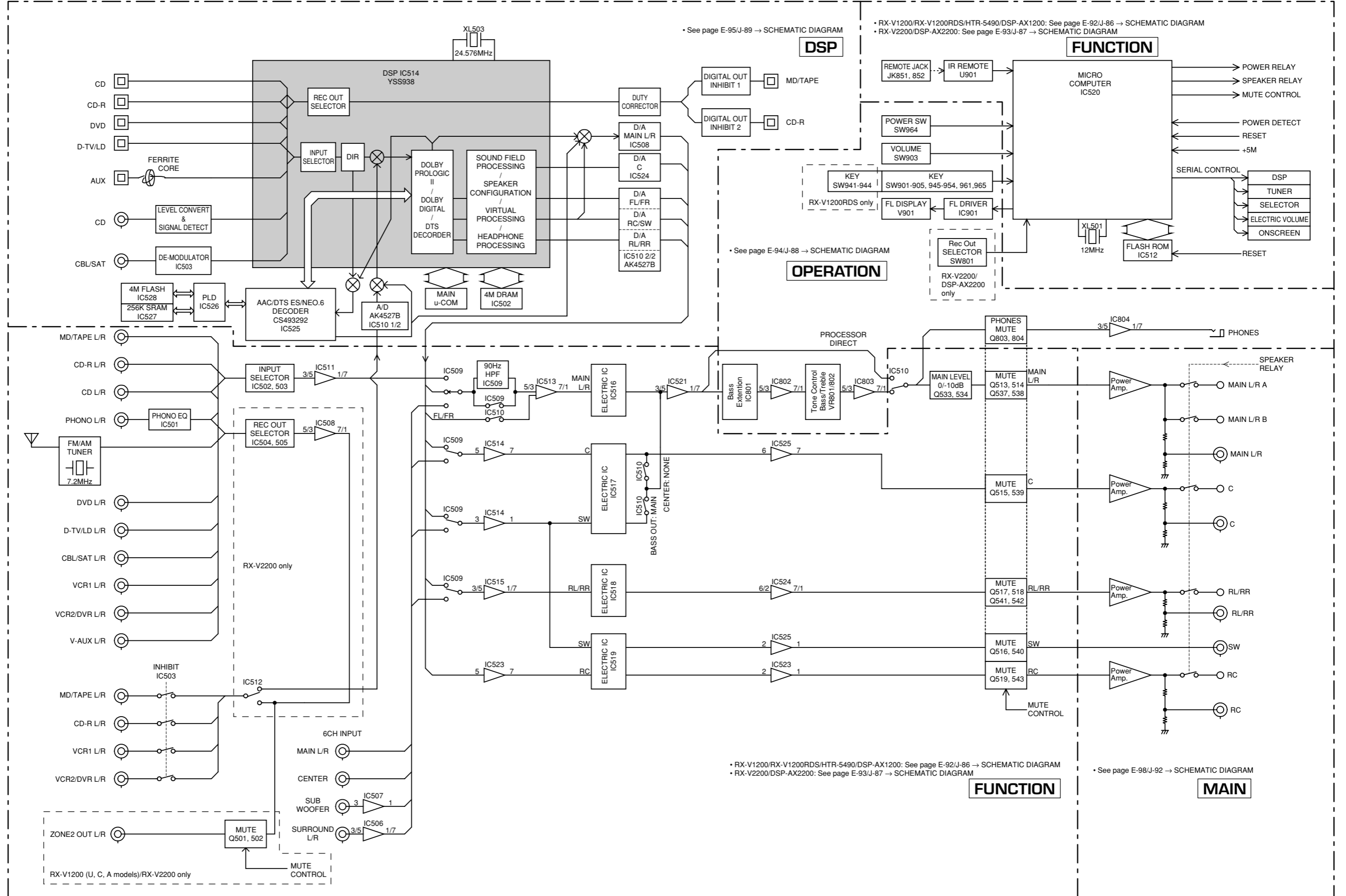

**■ BLOCK DIAGRAM (2/2)**

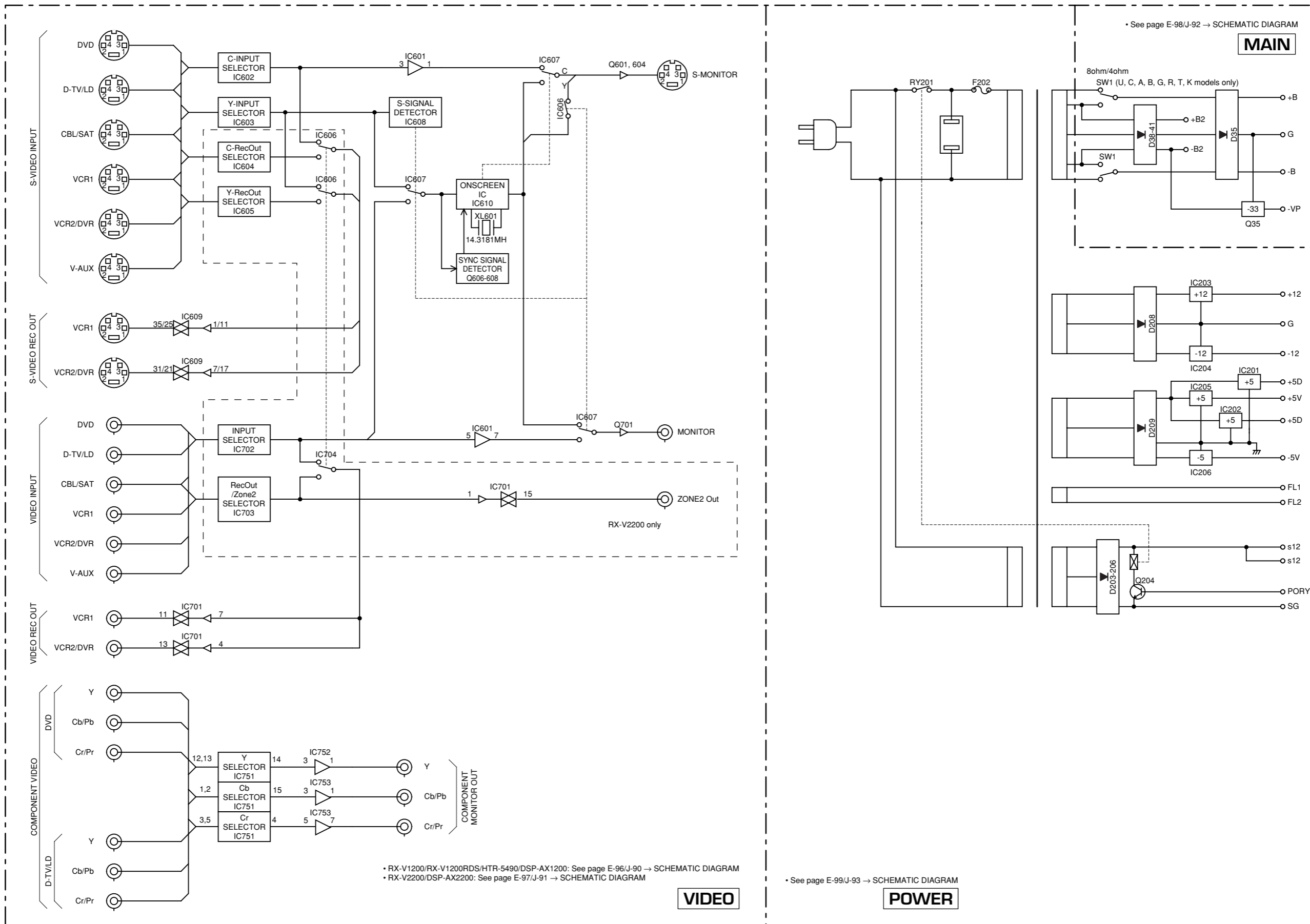



PRINTED CIRCUIT BOARD (Foil side)

FUNCTION P. C. B. (Lead Type Device)

Circuit No.	RX-V1200/RX-V1200RDS/HTR-5490/DSP-AX1200					RX-V2200/DSP-AX2200			
	J	U, C	R, T, K	A	BG	J	U, C	R, T	A
C508, 509, 517, 518, 521, 522, 625, 626	X	X	X	X	X	O	O	O	O
C533	X	O	X	O	X	O	O	O	O
C603, 604	X	X	X	O	O	X	X	X	O
C679, 692	X	X	O	O	O	X	X	X	X
D517, 518	X	O	X	O	X	O	O	O	O
IC504, 505, 508	X	X	X	X	X	O	O	O	O
J503, 504	X	O	X	O	X	X	X	X	X

X: NOT USED  
O: USED / APPLICABLE

Semiconductor Location

Ref. No.	Location	Ref. No.	Location	Ref. No.	Location	Ref. No.	Location	Ref. No.	Location
D501	B3	D508	C3	D518	C4	IC502	G3	IC513	E4
D503	B3	D509	C3	D519	D4	IC503	H3	IC514	E4
D504	B3	D510	C3	D521	D4	IC504	F3	IC515	E4
D505	B3	D511	C3	D523	E3	IC505	H3	IC516	D3
D506	C3	D512	C3	D525	D3	IC506	H5	IC517	D4
D507	D5	D517	C4	IC501	H4	IC507	H5	IC518	D4
						IC508	F4	IC519	D4
						IC509	F5	IC520	B4
						IC510	E5	IC521	E5
						IC511	F5	IC522	C3
						IC512	A4	IC523	D5
								IC524	D5
								IC525	D5

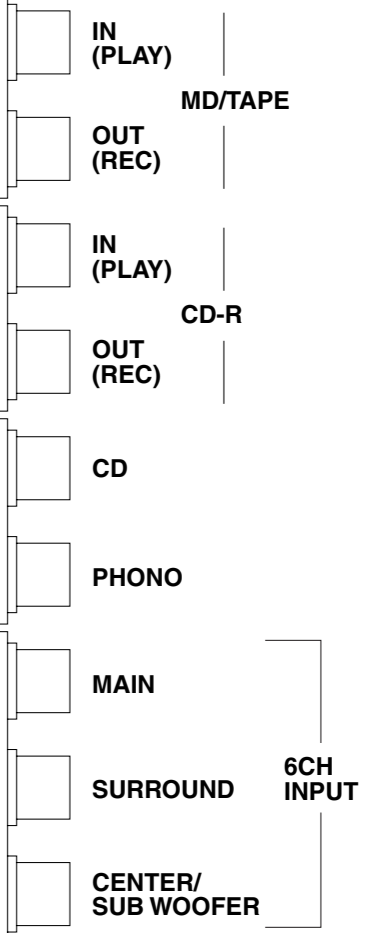
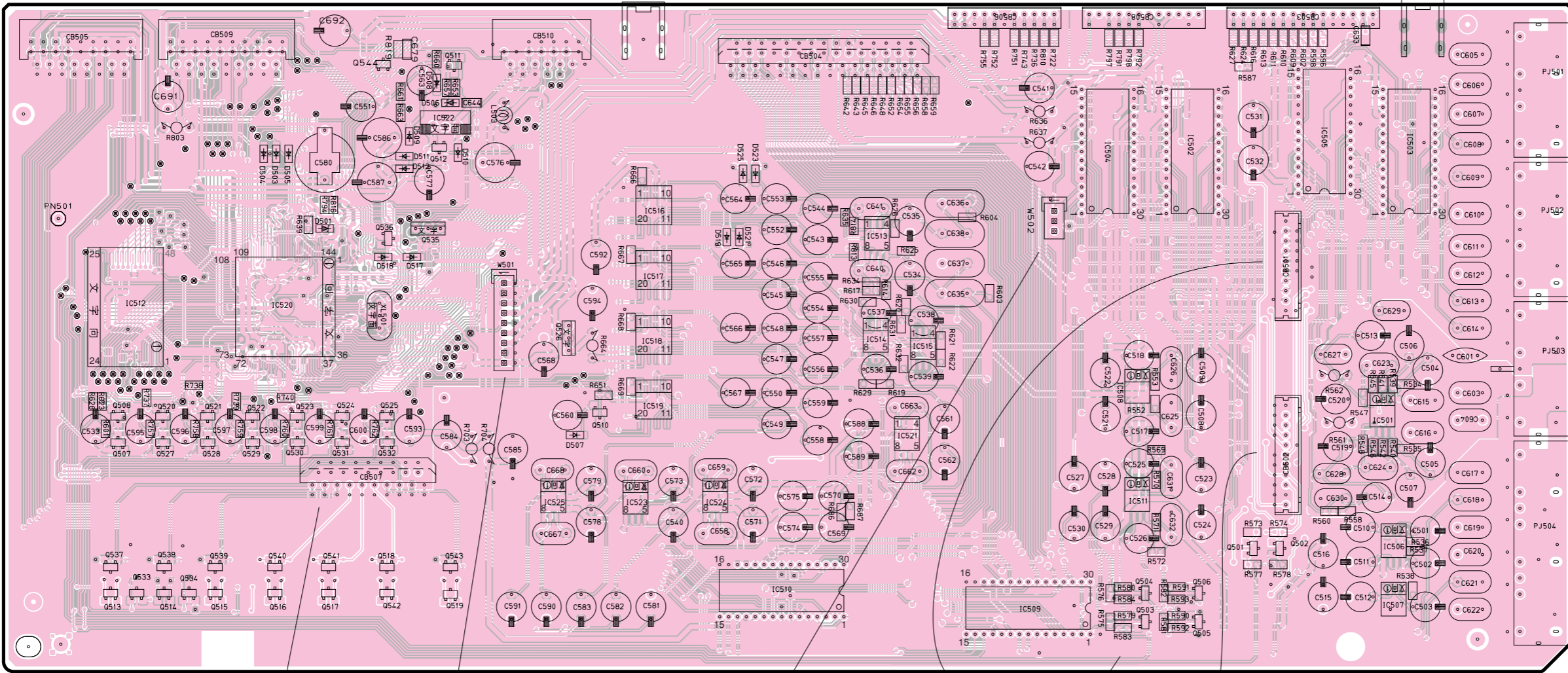
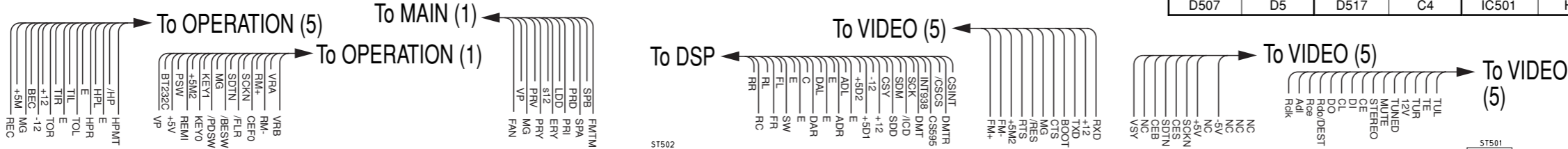

Semiconductor Location

Ref. No.	Location	Ref. No.	Location	Ref. No.	Location	Ref. No.	Location
Q501	G5	Q513	A5	Q524	B4	Q535	C4
Q502	G5	Q514	B5	Q525	C4	Q536	C4
Q503	G5	Q515	B5	Q526	D4	Q537	A5
Q504	G5	Q516	B5	Q527	B5	Q538	B5
Q505	G5	Q517	B5	Q528	B5	Q539	B5
Q506	G5	Q518	C5	Q529	B5	Q540	B5
Q507	A5	Q519	C5	Q530	B5	Q541	B5
Q508	A4	Q520	B4	Q531	B5	Q542	C5
Q510	D4	Q521	B4	Q532	C5	Q543	C5
Q511	C3	Q522	B4	Q533	A5	Q544	C3
Q512	C3	Q523	B4	Q534	B5		

Circuit No.	RX-V1200/RX-V1200RDS/HTR-5490/DSP-AX1200					RX-V2200/DSP-AX2200			
	J	U, C	R, T, K	A	BG	J	U, C	R, T	A
Q501, 502, 507, 508, 535, 536	X	O	X	O	X	X	O	O	O
Q544	X	X	O	O	O	O	O	O	O
R552, 553	X	X	X	X	X	O	O	O	O
R573, 574, 577, 578, 601, 623, 665	X	O	X	O	X	X	X	X	X
R810	X	O	X	O	X	X	X	X	X
R819	X	X	O	O	O	O	O	O	O

X: NOT USED  
O: USED / APPLICABLE

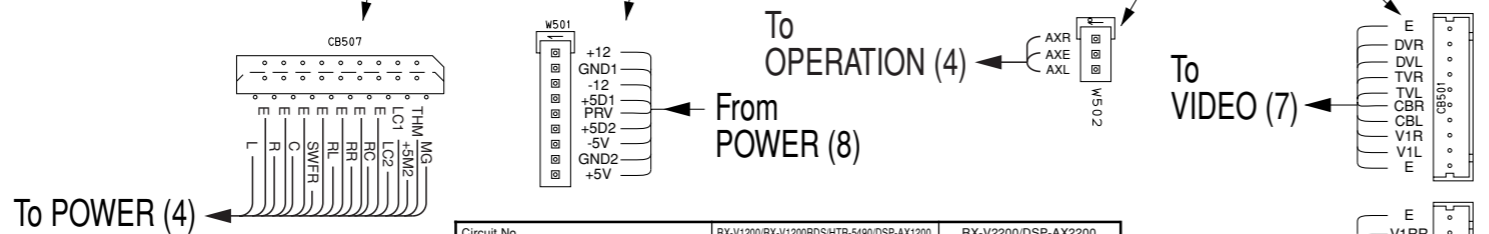

1 ■ PRINTED CIRCUIT BOARD (Foil side)

2 FUNCTION P. C. B. (Surface Mount Device)

Circuit No.	RX-V1200/RX-V1200RDS/HTR-5490/DSP-AX1200					RX-V2200/DSP-AX2200			
	J	U, C	R, T, K	A	BG	J	U, C	R, T	A
C666, 671, 676, 678	X	O	X	O	O	X	O	X	O
J501, 502	O	O	O	O	O	X	X	X	X
J503, 504	X	O	X	O	X	X	X	X	X
R543, 544	X	X	X	X	X	O	O	O	O
R563, 564	X	X	X	X	X	X	O	O	O
R565, 566	X	X	X	X	X	O	O	O	O
R567, 662	X	X	O	X	X	X	X	O	X
R594, 665, 763, 809	X	O	X	O	X	X	O	O	O
R671	O	O	O	O	O	X	X	X	X
R672	O	X	O	X	O	O	X	X	X
R805	X	X	X	X	X	X	O	O	O

X: NOT USED  
O: USED / APPLICABLE

• Semiconductor Location

Ref. No.	Location
D502	A4
D513	B4
D514	D4
D515	D4
D520	D4
D522	E4
D524	E3
D526	E3
D531	C4
D532	C4
Q509	A4
Q547	G5
Q548	G5

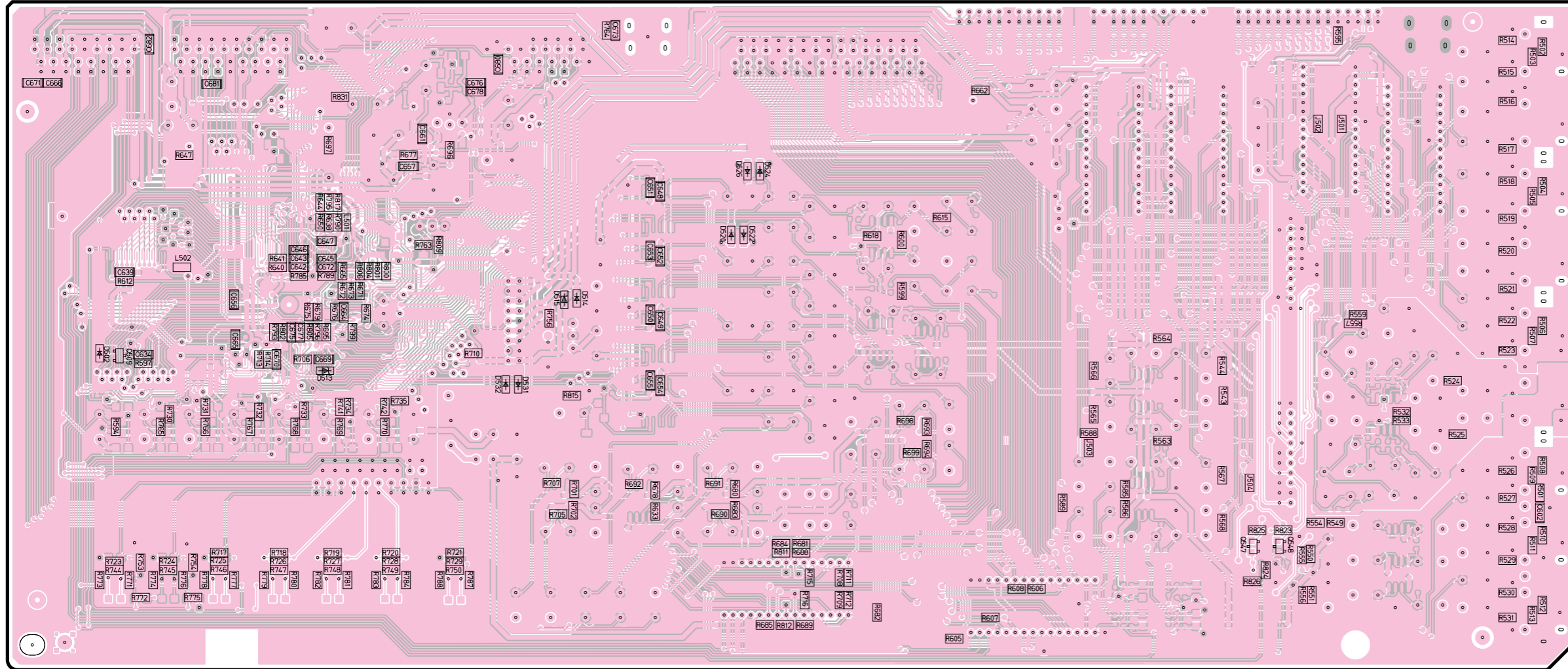

1 ■ PRINTED CIRCUIT BOARD (Foil side)

OPERATION (1) P. C. B. (Lead Type Device)

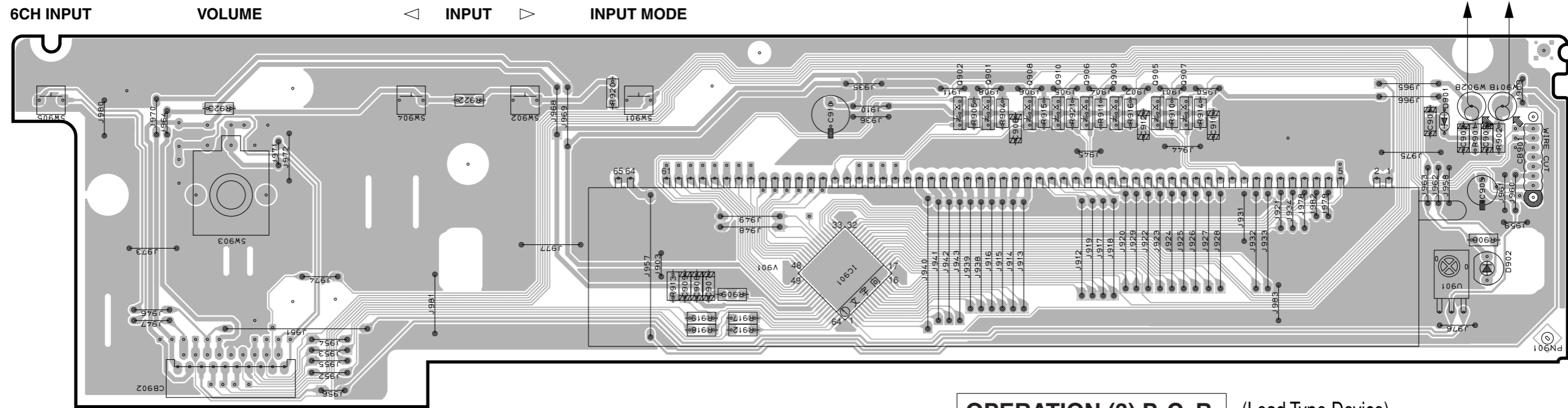

OPERATION (3) P. C. B. (Lead Type Device)

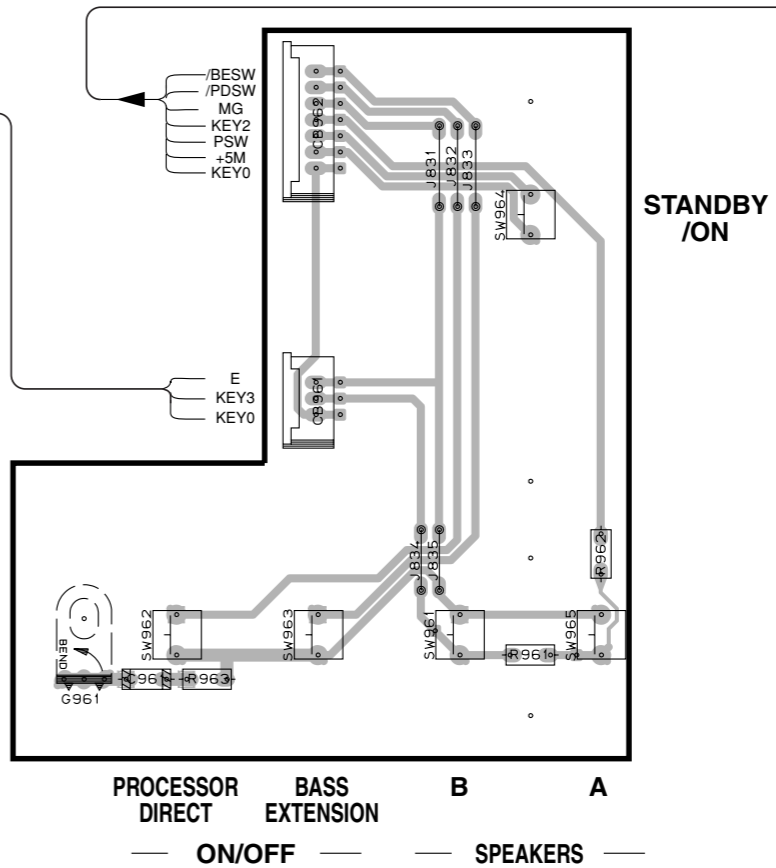

• Semiconductor Location

Ref. No.	Location
D901	I2
D902	I3
IC901	F3
Q901	F2
Q902	F2
Q905	G2
Q906	G2
Q907	G2
Q908	G2
Q909	G2
Q910	G2

OPERATION (2) P. C. B. (Lead Type Device)

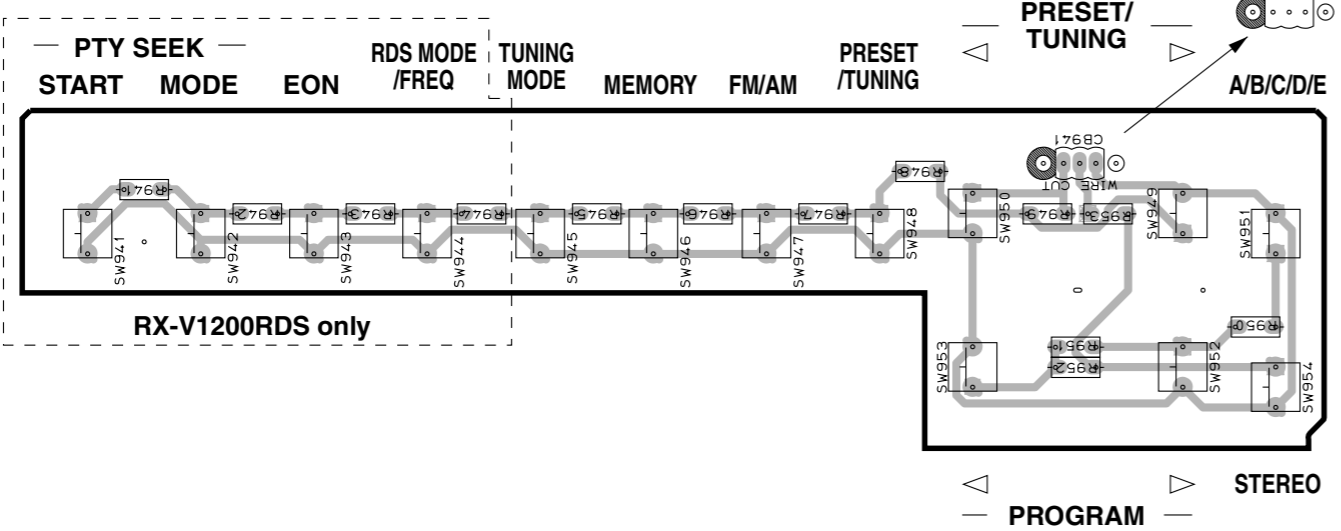

From FUNCTION

VP - BT232C  
+5V PSW  
REM +5M2  
KEY0 KEY1  
/POSW MG  
/BESW SDTN  
/FLR SKN  
CEFO RM+  
RM- VRA  
VRB

Circuit No.	RX-V1200/RX-V1200RDS/HTR-5490/DSP-AX1200				RX-V2200/DSP-AX2200			
	J, R, T, K	U, C, A	B, G	J	U, C, A, R, T	J	U, C, A, R, T	J
D902	X	O	X	X	O			
R908	X	O	X	X	O			
R941-944	X	X	O	X	X			
SW941-944	X	X	O	X	X			

X: NOT USED  
O: USED / APPLICABLE

PRINTED CIRCUIT BOARD (Foil side)

OPERATION (4) P. C. B. (Lead Type Device)

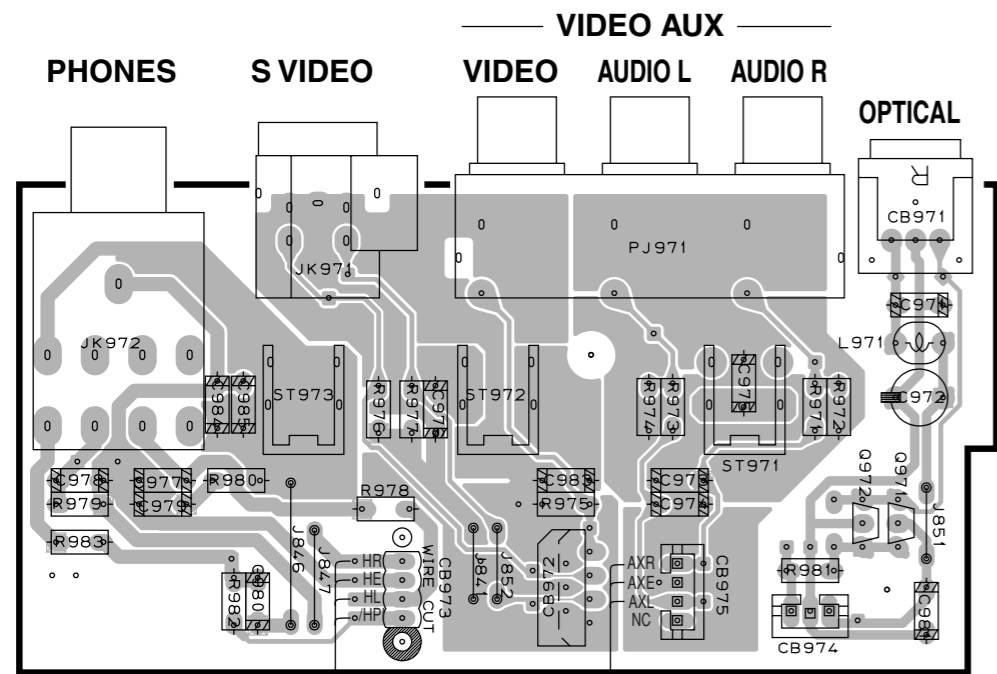

OPERATION (5) P. C. B. (Lead Type Device)

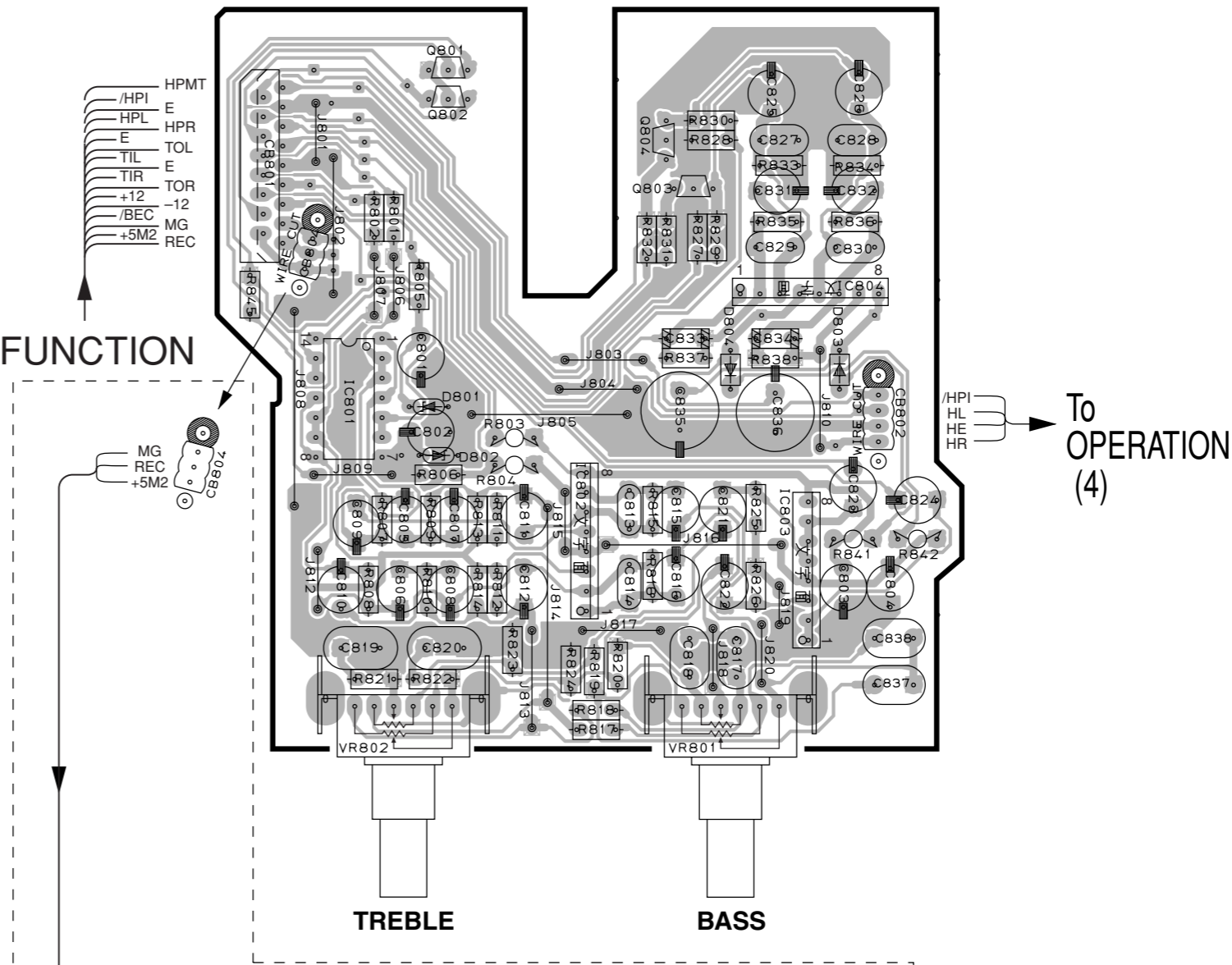

From OPERATION (5)

From FUNCTION

From DSP

From VIDEO (1)

OPERATION (7) P. C. B. (Lead Type Device)

From OPERATION (1)

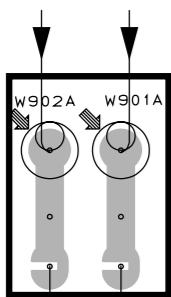

From Power Transformer

OPERATION (6) P. C. B. (Lead Type Device)

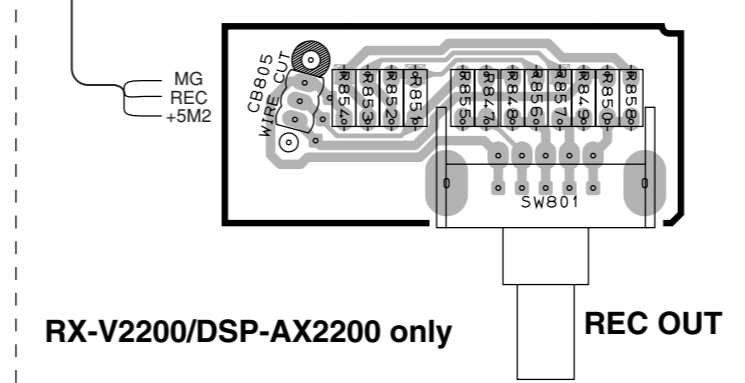

RX-V2200/DSP-AX2200 only

REC OUT

Semiconductor Location

Ref. No.	Location
D801	G3
D802	G3
D803	H3
D804	H3
IC801	F3
IC802	G4
IC803	H4
IC804	H3
Q801	G2
Q802	G2
Q803	H2
Q804	G2
Q971	D3
Q972	D3

1 ■ PRINTED CIRCUIT BOARD (Foil side)

DSP P. C. B. (Lead Type Device)

• Semiconductor Location

Ref. No.	Location
D508	C6
D509	C6
D510	C5
D511	C5
D512	C5
D513	C5
D514	C5
D515	C5
IC501	F5
IC502	F5
IC503	F4
IC508	D4
IC510	D6
IC512	D3
IC513	F4
IC514	E4
IC515	E3
IC516	F3
IC517	F3
IC524	D5
IC525	F6
IC526	F7
IC527	E6
IC528	E7

From FUNCTION

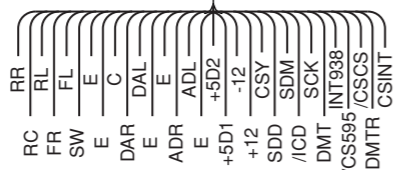

To OPERATION (4)

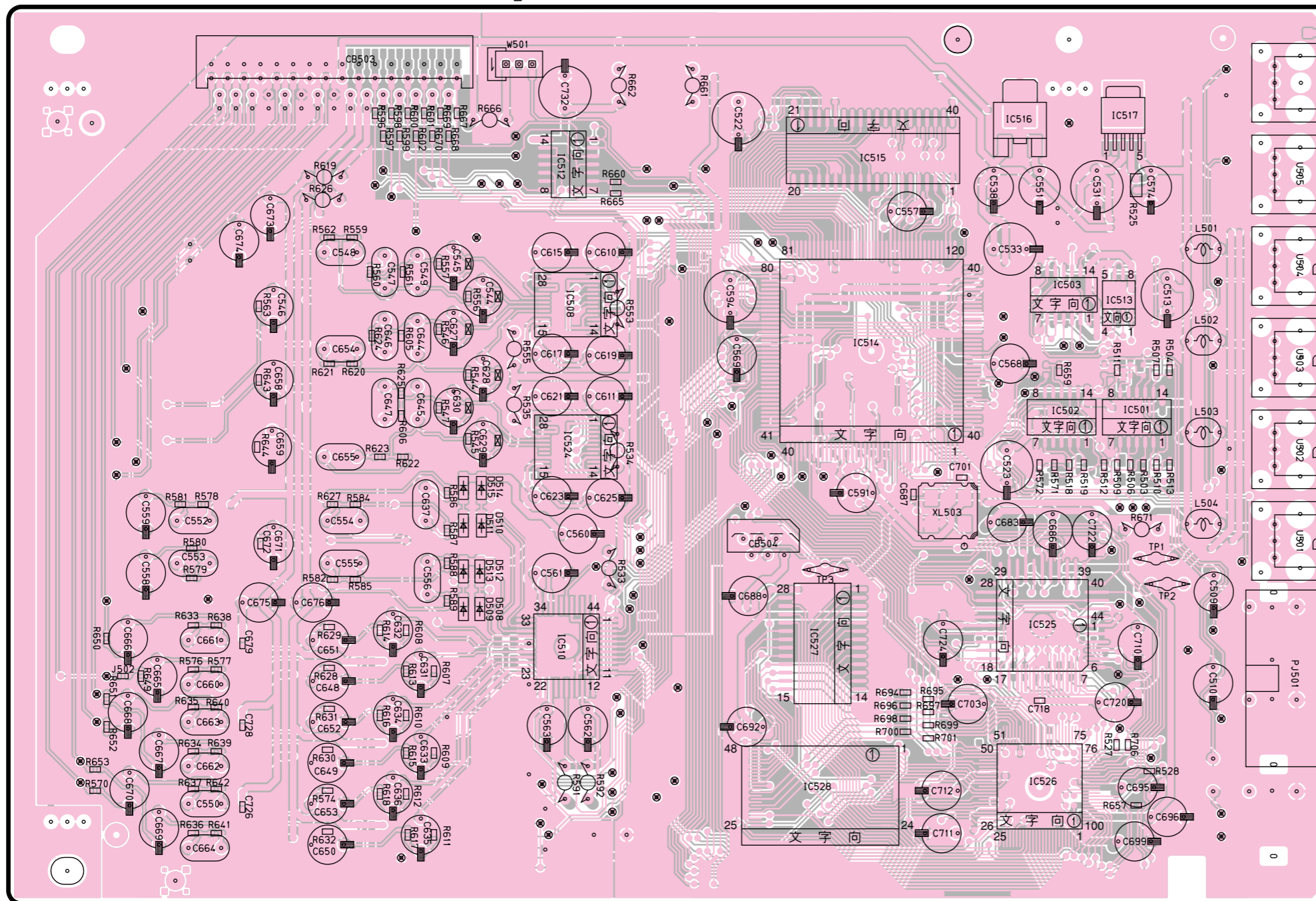

MD/  
TAPE  
DIGITAL  
OUTPUT

CD-R

CD

CD-R

DVD

DIGITAL  
INPUT

D-TV  
/LD

CD

CBL  
/SAT

Circuit No.	J	U, C, R, T, K, A, B, G
R688	X	O

X: NOT USED  
O: USED / APPLICABLE

PRINTED CIRCUIT BOARD (Foil side)

• Semiconductor Location

Ref. No.	Location
D501	G5
D502	G5
D503	G5
D504	G4
D505	G4
D506	G5
D507	G4
D516	G4
D517	F4
D518	F4
D519	D6
D520	D6
D521	D6
D522	D6
D523	D6
D524	D6
D525	D6
D526	D6
D527	D7
D528	D7
D529	D7
D530	D7
D531	B4
D532	B4
D533	C4
D534	B4
D537	D7
D538	D7
IC509	C4
IC518	C5
IC519	C5
IC520	C5
IC521	C6
IC522	C6
IC523	C7
Q501	D6
Q502	D6
Q503	D6
Q504	D6
Q505	D7
Q506	D7
Q507	B4
Q508	B5
Q509	B4
Q510	C6
Q511	C6
Q512	C6
Q513	C6
Q514	C7
Q515	C7
Q516	B5
Q517	B5

DSP P. C. B. (Surface Mount Device)

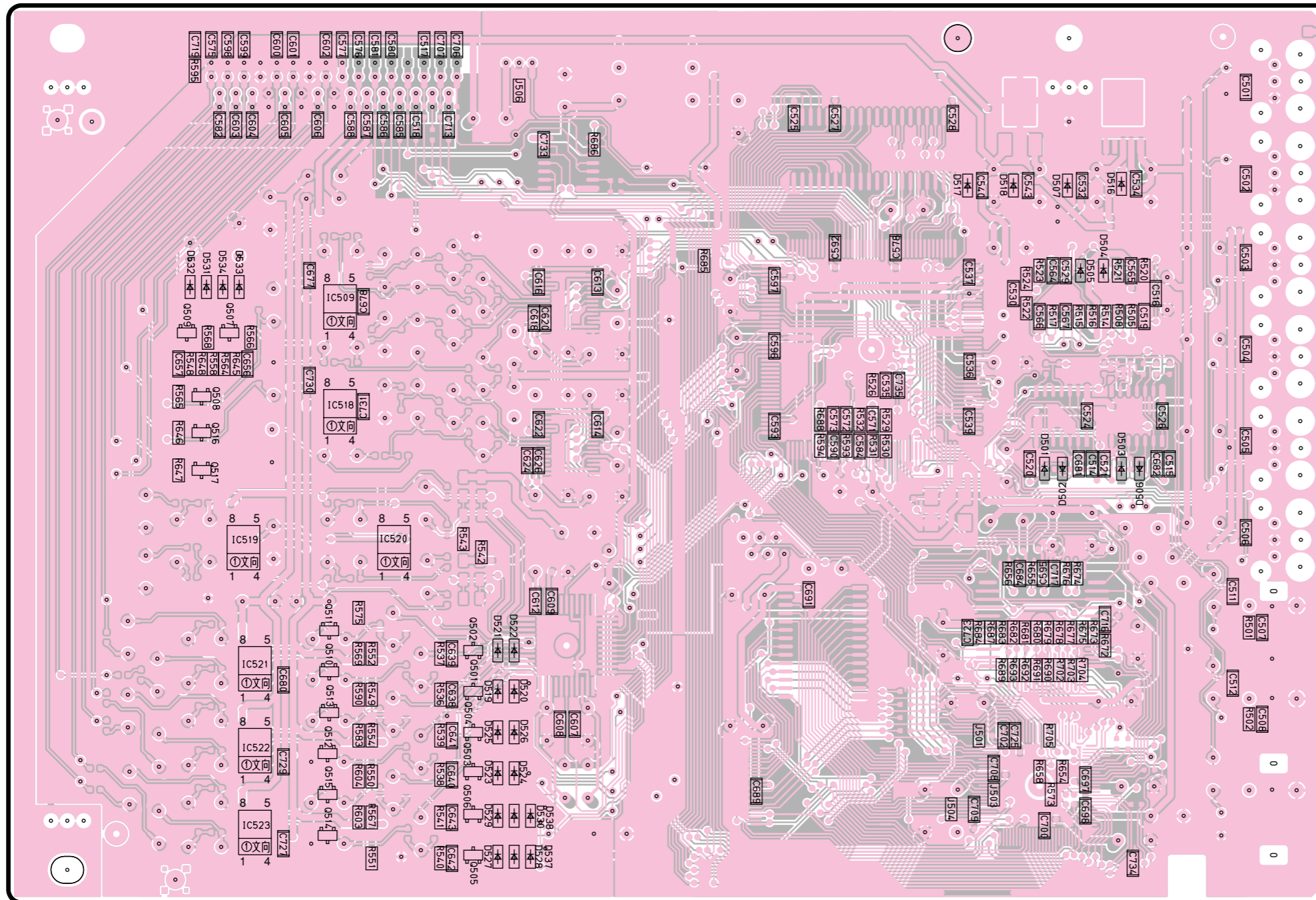

Circuit No.	J	U, C, R, T, K, A, B, G
R688	X	O

X: NOT USED  
O: USED / APPLICABLE

# RX-V1200/RX-V1200RDS/HTR-5490/DSP-AX1200 PRINTED CIRCUIT BOARD (Foil side)

Circuit No.	J	U, C	R, T, K	A	B, G
C581, 591-595, 596-599	X	X	X	X	O
IC581	X	X	X	X	O
L581	X	X	X	X	O
R561, 562, 567, 568, 577, 578, 859	X	O	X	O	X
R583	X	O	O	X	X
R584	O	X	X	O	O
R585	X	X	O	O	O
R586	O	O	X	X	X
R591, 593-598	X	X	X	X	O
R681	X	X	X	O	O
R682	O	O	O	X	X
R683	X	O	O	O	X
R684	O	X	X	X	O
SW551	X	X	O	X	X
XL581	X	X	X	X	O

X: NOT USED  
O: USED / APPLICABLE

## Semiconductor Location

Ref. No.	Location	Ref. No.	Location
D601	G4	IC608	G4
D602	G4	IC609	H6
D603	G5	IC610	B6
D604	G5	IC611	B6
D605	G5	Q601	D6
D606	F5	Q602	D6
D607	G4	Q603	B5
D608	G4	Q604	D6
D609	G4	Q605	B6
D610	G4	Q606	B5
IC601	H4	Q607	A5
IC602	C4	Q608	B5
IC603	D4	Q609	B5
IC607	B4		

### VIDEO (1) P. C. B. (Lead Type Device)

### VIDEO (1) P. C. B. (Surface Mount Device)

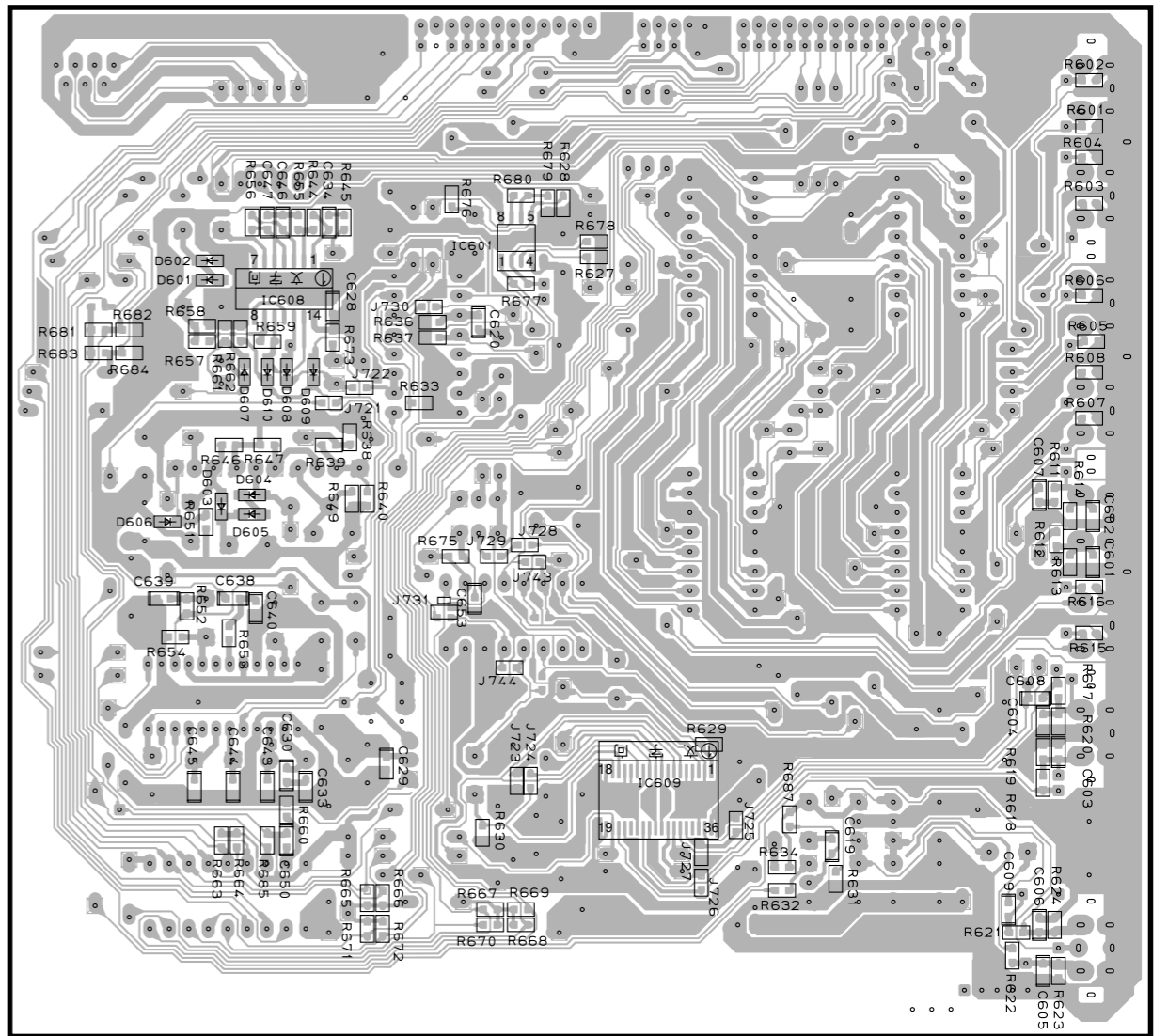
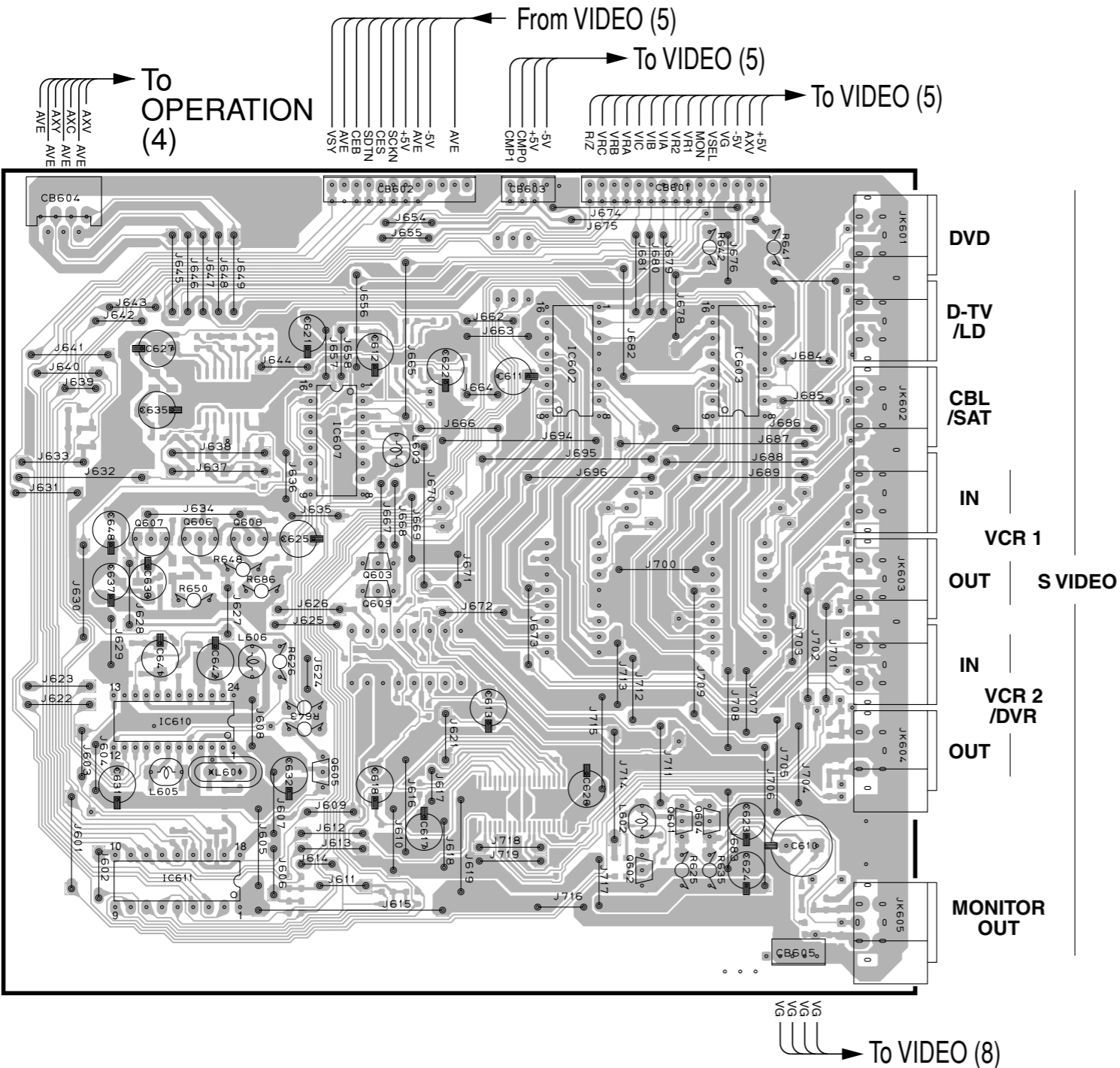

**RX-V1200/RX-V1200RDS/HTR-5490/DSP-AX1200 PRINTED CIRCUIT BOARD (Foil side)**

Circuit No.	J	U, C	R, T, K	A	B, G
C581, 591-595, 596-599	X	X	X	X	O
IC581	X	X	X	X	O
L581	X	X	X	X	O
R561, 562, 567, 568, 577, 578, 859	X	O	X	O	X
R583	X	O	O	X	X
R584	O	X	X	O	O
R585	X	X	O	O	O
R586	O	O	X	X	X
R591, 593-598	X	X	X	X	O
R681	X	X	X	O	O
R682	O	O	O	X	X
R683	X	O	O	O	X
R684	O	X	X	X	O
SW551	X	X	O	X	X
XL581	X	X	X	X	O

X: NOT USED  
O: USED / APPLICABLE

**VIDEO (2) P. C. B.** (Lead Type Device)

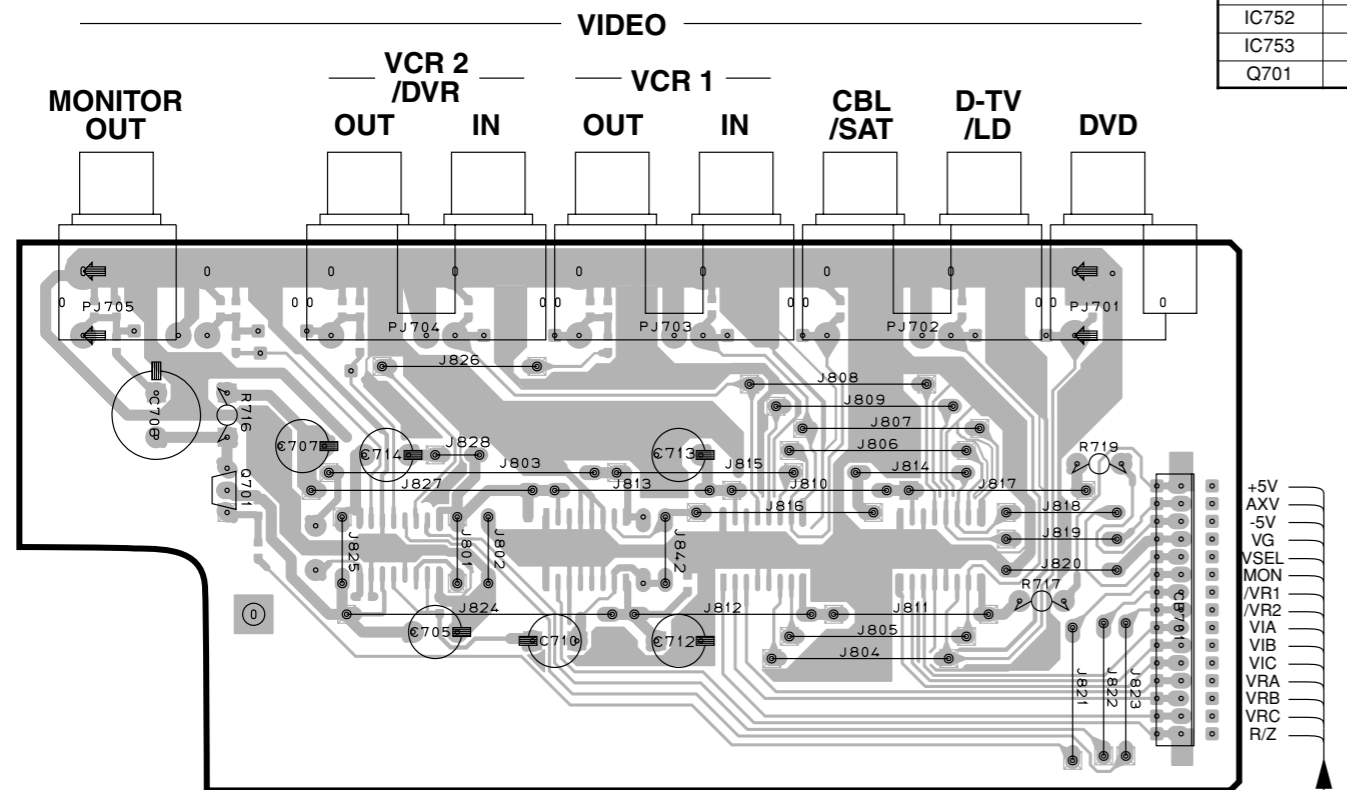

• Semiconductor Location

Ref. No.	Location
IC701	B6
IC702	D6
IC751	G6
IC752	G6
IC753	C6
Q701	A3

**VIDEO (4) P. C. B.** (Lead Type Device)

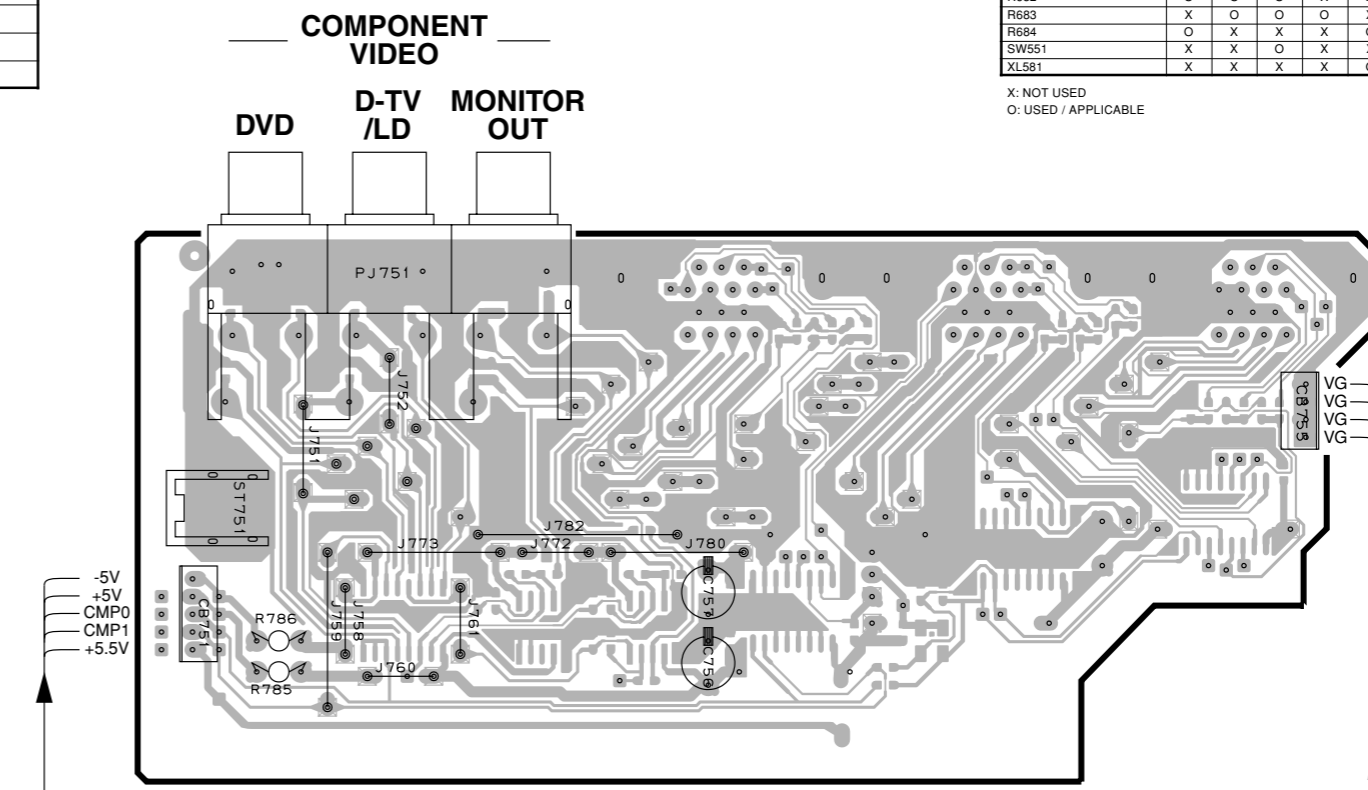

**VIDEO (2) P. C. B.** (Surface Mount Device)

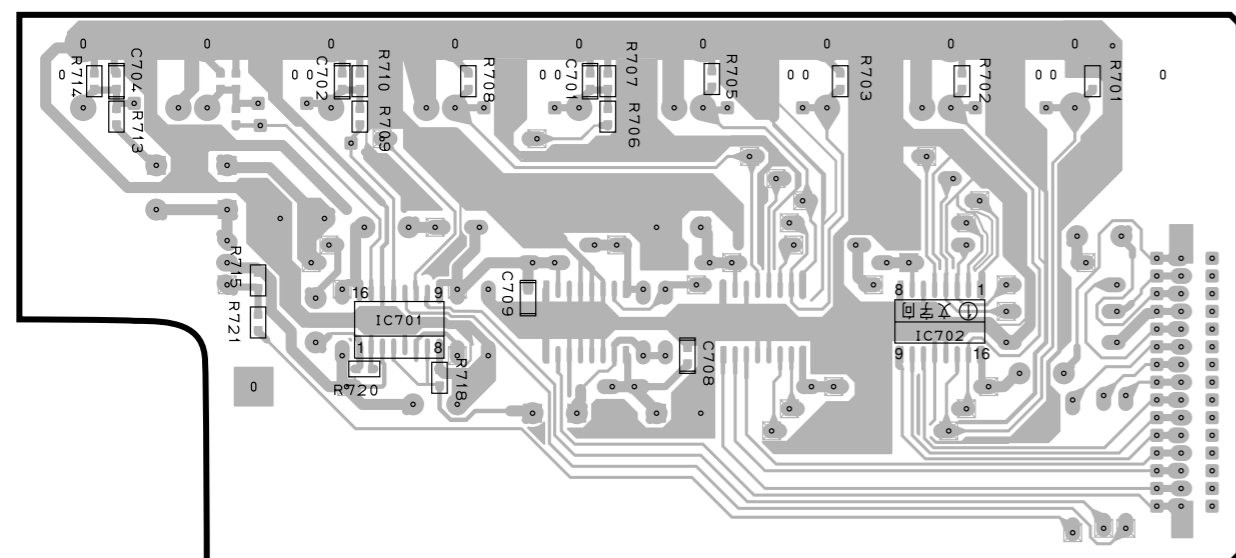

**VIDEO (4) P. C. B.** (Surface Mount Device)

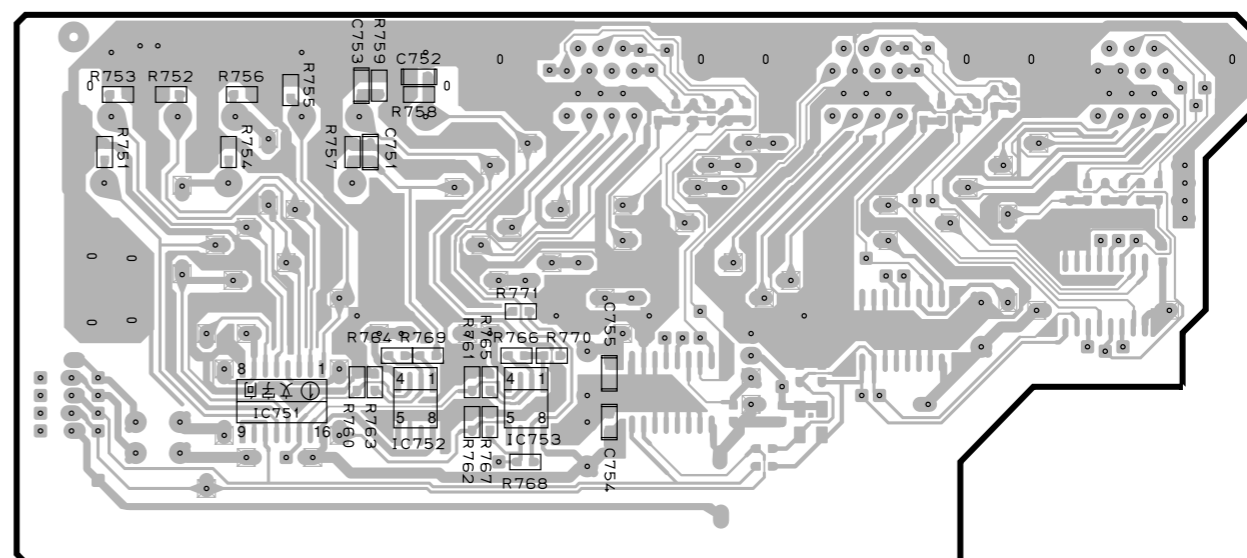



# RX-V1200/RX-V1200RDS/HTR-5490/DSP-AX1200 PRINTED CIRCUIT BOARD (Foil side)

## VIDEO (5) P. C. B. (Lead Type Device)

## VIDEO (5) P. C. B. (Surface Mount Device)

Circuit No.	J	U. C	R. T. K	A	B. G
C581, 591-595, 596-599	X	X	X	X	O
IC581	X	X	X	X	O
L581	X	X	X	X	O
R561, 562, 567, 568, 577, 578, 859	X	O	X	O	X
R583	X	O	O	X	X
R584	O	X	X	O	O
R585	X	X	O	O	O
R586	O	O	X	X	X
R591, 593-598	X	X	X	X	O
R681	X	X	X	O	O
R682	O	O	O	X	X
R683	X	O	O	O	X
R684	O	X	X	X	O
SW551	X	X	O	X	X
XL581	X	X	X	X	O

X: NOT USED  
O: USED / APPLICABLE

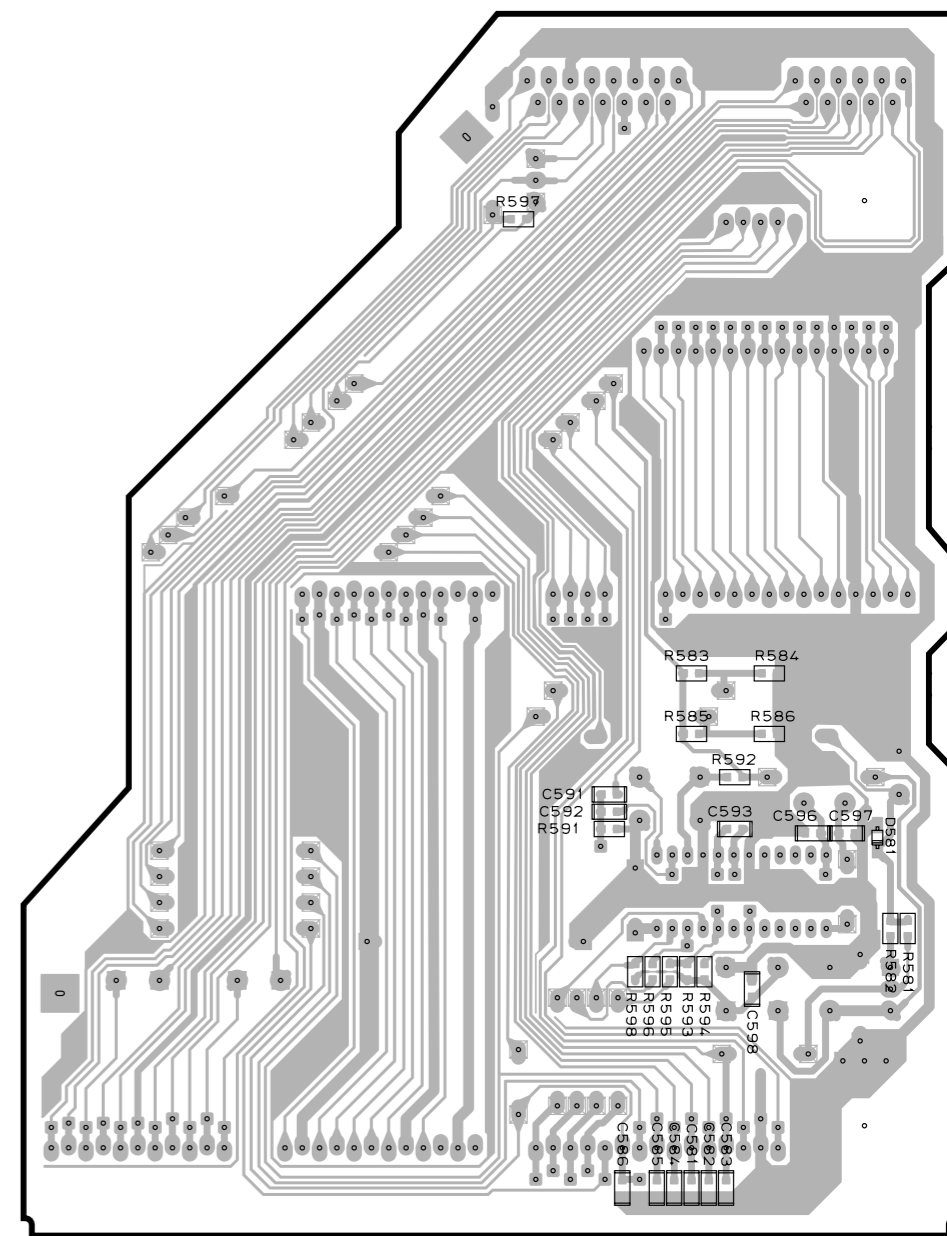
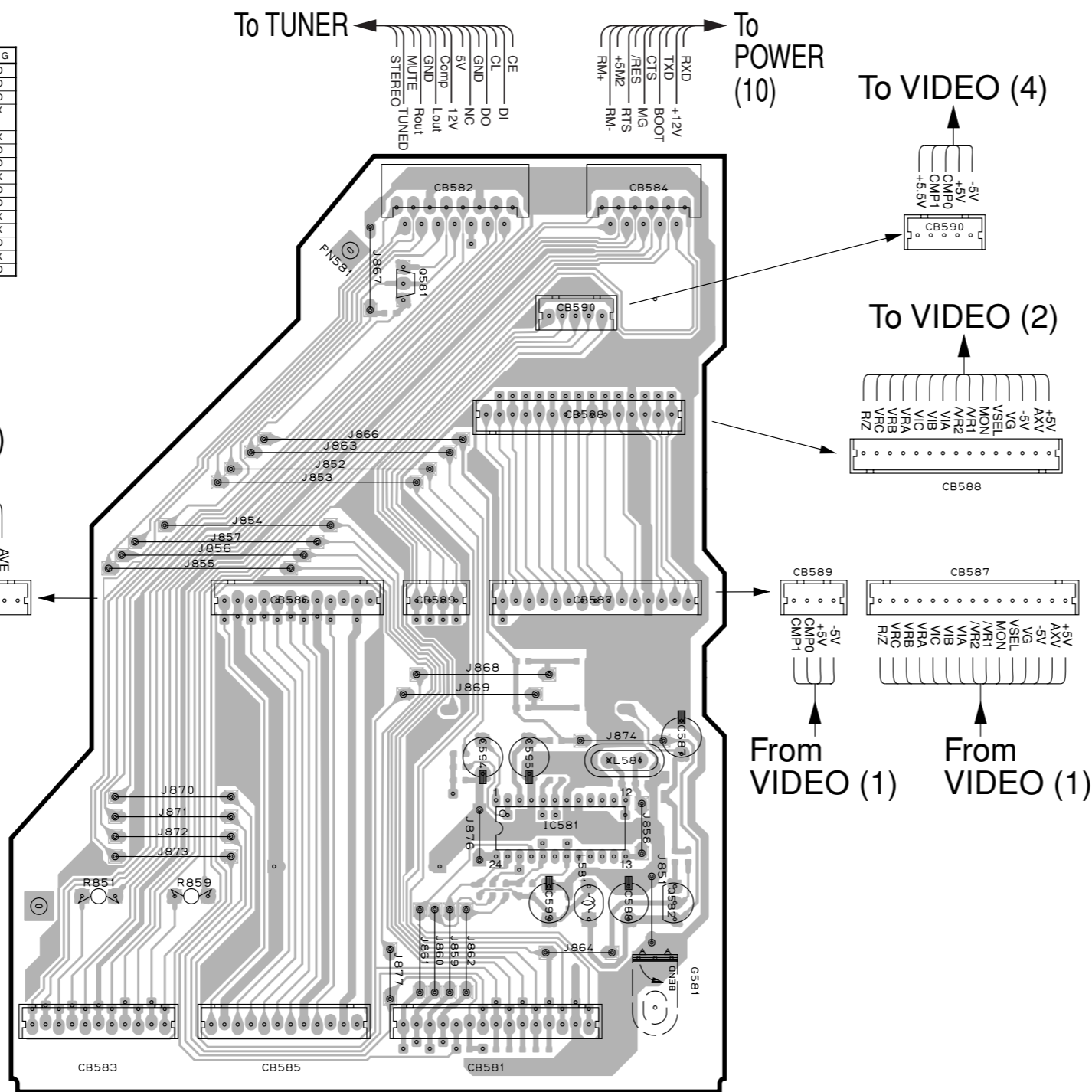

### Semiconductor Location

Ref. No.	Location
D581	J5
IC581	D5
Q581	D3
Q582	E6

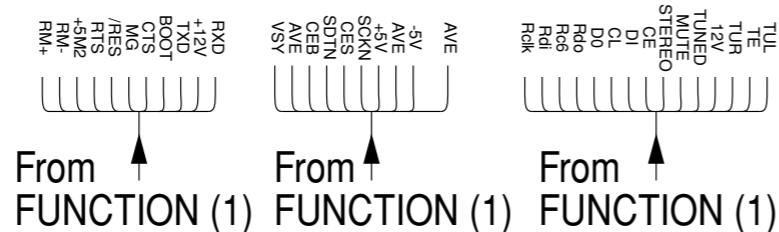

**RX-V1200/RX-V1200RDS/HTR-5490/DSP-AX1200 PRINTED CIRCUIT BOARD (Foil side)**

**VIDEO (6) P. C. B.** (Lead Type Device)

**VIDEO (6) P. C. B.** (Surface Mount Device)

**VIDEO (7) P. C. B.** (Lead Type Device)

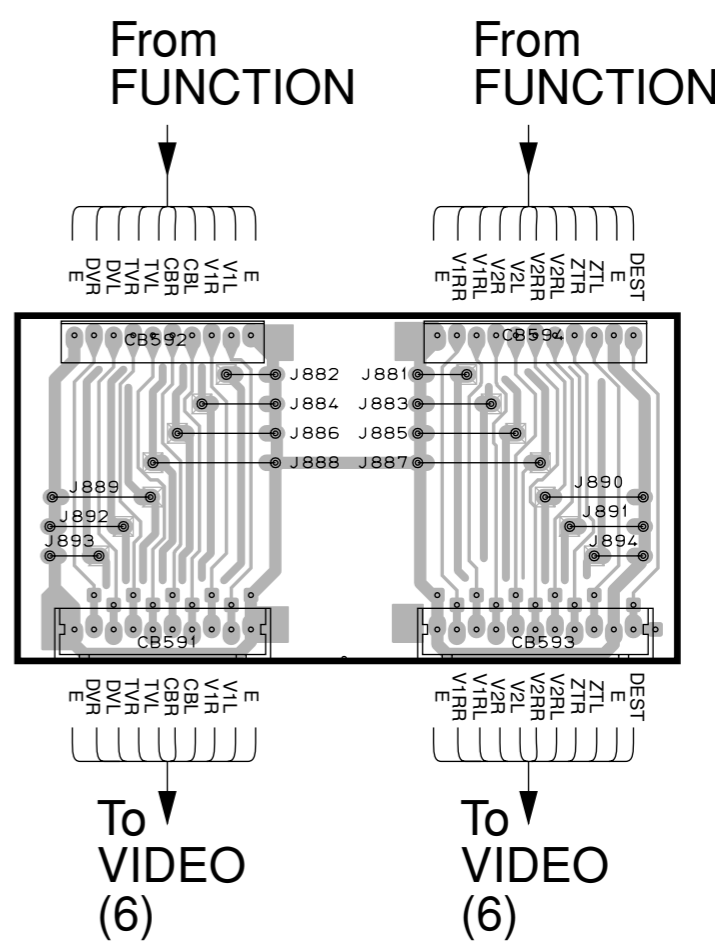
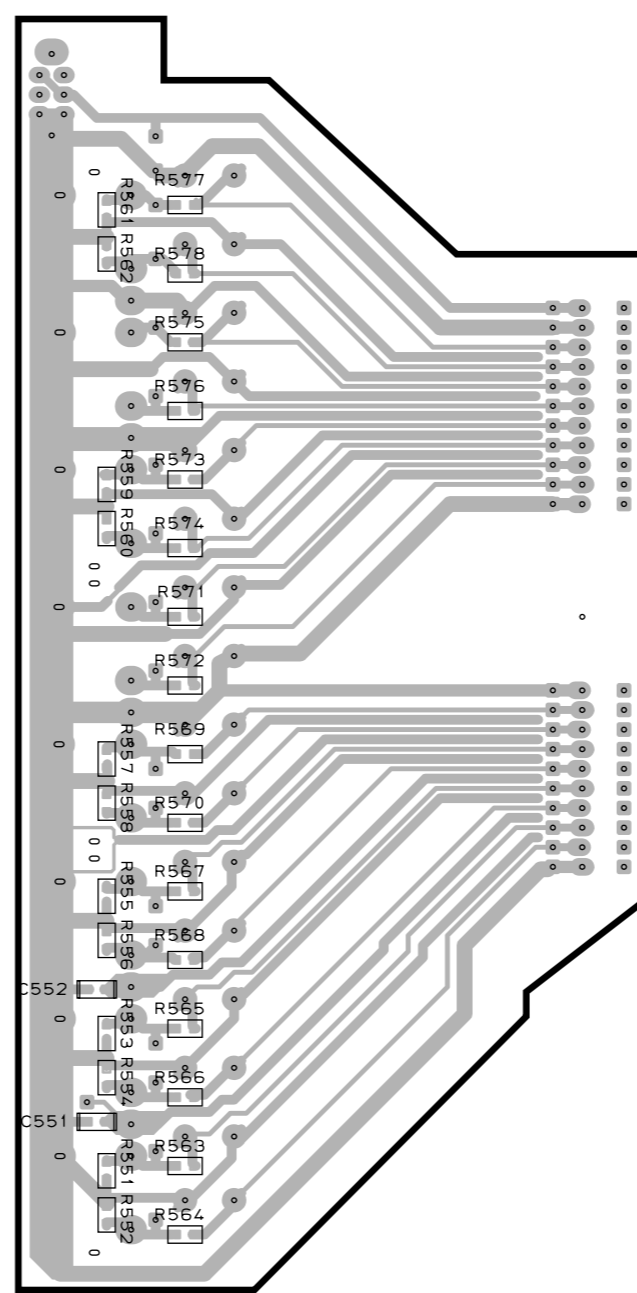
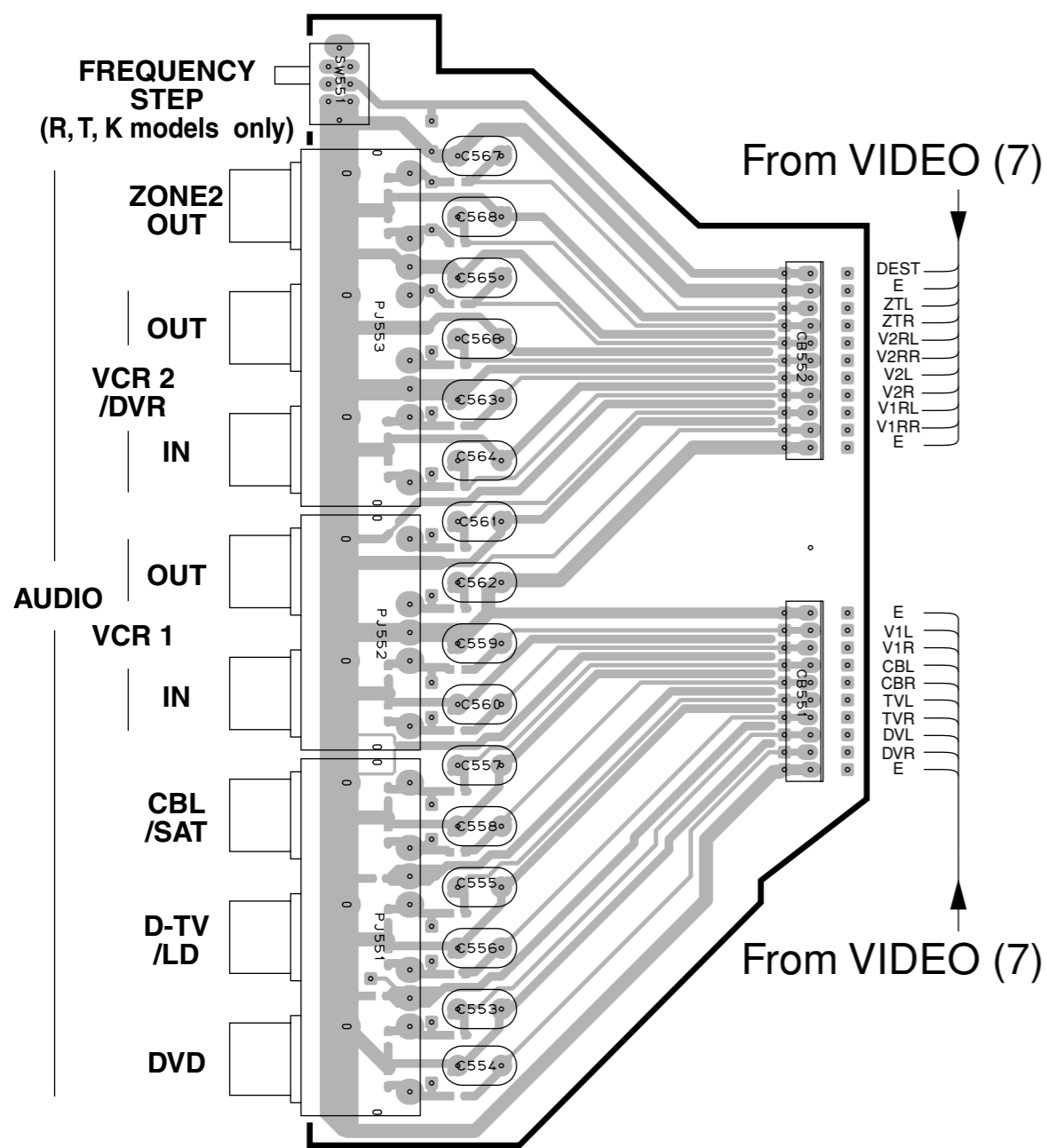

**VIDEO (8) P. C. B.** (Lead Type Device)

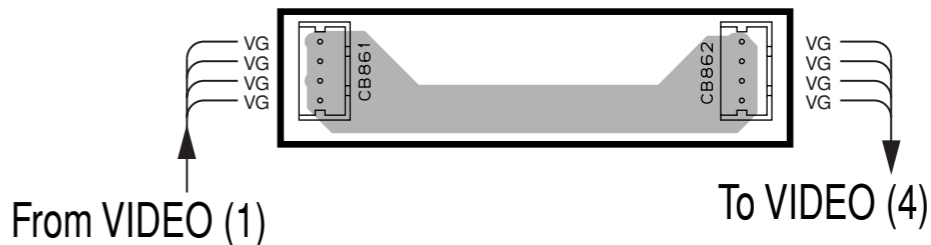

Circuit No.	J	U.C	R, T, K	A	B, G
C581, 591-595, 596-599	X	X	X	X	O
IC581	X	X	X	X	O
L581	X	X	X	X	O
R561, 562, 567, 568, R577, 578, 859	X	O	X	O	X
R583	X	O	O	X	X
R584	O	X	X	O	O
R585	X	X	O	O	O
R586	O	O	X	X	X
R591, 593-598	X	X	X	X	O
R681	X	X	X	O	O
R682	O	O	O	X	X
R683	X	O	O	O	X
R684	O	X	X	X	O
SW551	X	X	O	X	X
XL581	X	X	X	X	O

X: NOT USED  
O: USED / APPLICABLE

1 ■ **RX-V2200/DSP-AX2200 PRINTED CIRCUIT BOARD (Foil side)**

Circuit No.	J	U,C	R,T	A
IC606	X	O	O	O
J741, 742	O	X	X	X
Q609	O	X	X	X
R674, 683	X	O	O	O
R675, 684	O	X	X	X
R681	X	X	X	O
R682	O	O	O	X

X: NOT USED  
 O: USED / APPLICABLE

• **Semiconductor Location**

Ref. No.	Location	Ref. No.	Location
D601	G4	IC606	C5
D602	G4	IC607	B4
D603	G5	IC608	G4
D604	G5	IC609	H6
D605	G5	IC610	B6
D606	F5	IC611	B6
D607	G4	Q601	D6
D608	G4	Q602	D6
D609	G4	Q603	B5
D610	G4	Q604	D6
IC601	H4	Q605	B6
IC602	C4	Q606	B5
IC603	D4	Q607	A5
IC604	C5	Q608	B5
IC605	D5	Q609	B5

2  
 3  
**VIDEO (1) P. C. B. (Lead Type Device)**

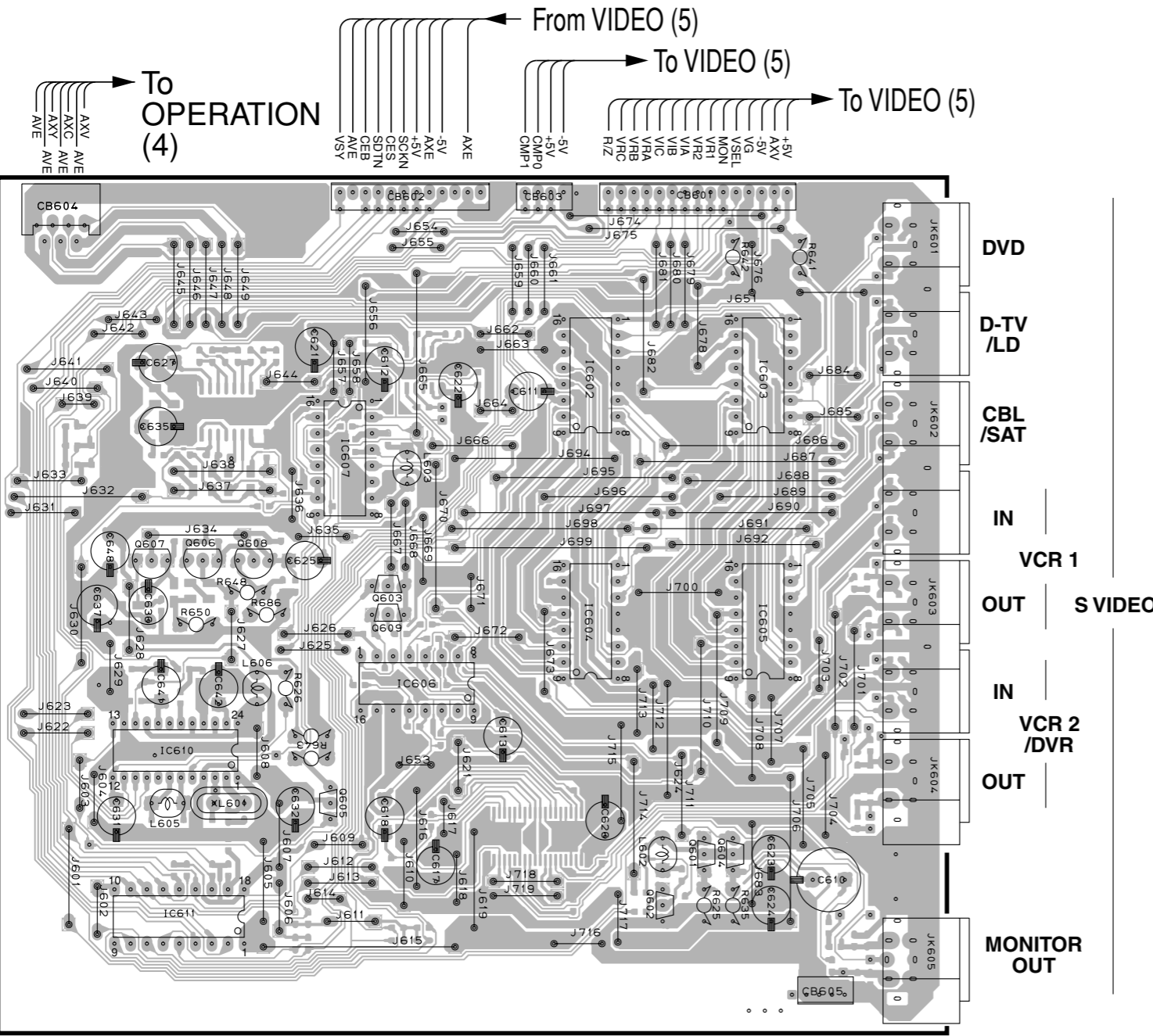

4  
**VIDEO (1) P. C. B. (Surface Mount Device)**

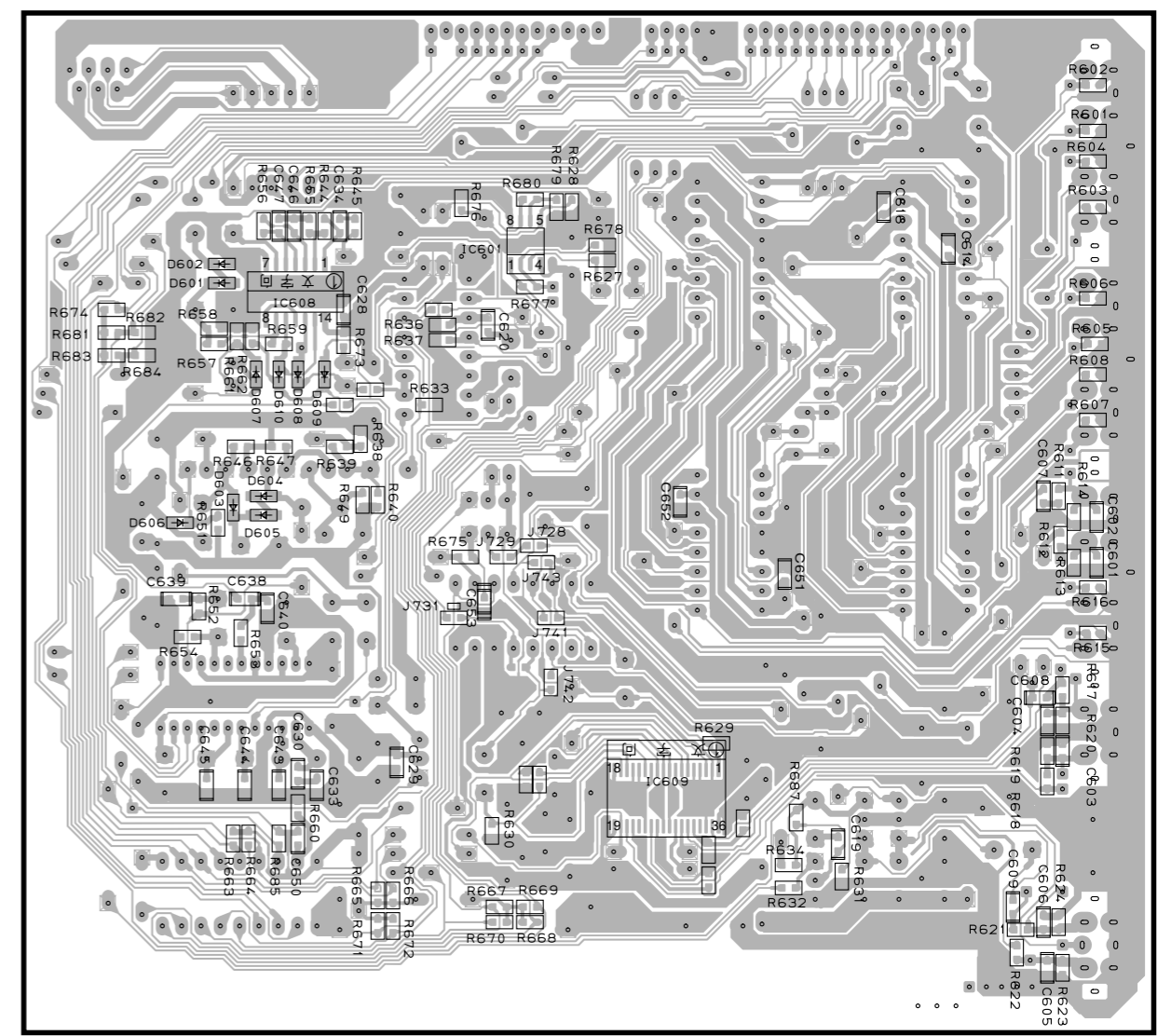

**RX-V2200/DSP-AX2200 PRINTED CIRCUIT BOARD (Foil side)**

**VIDEO (2) P. C. B.** (Lead Type Device)

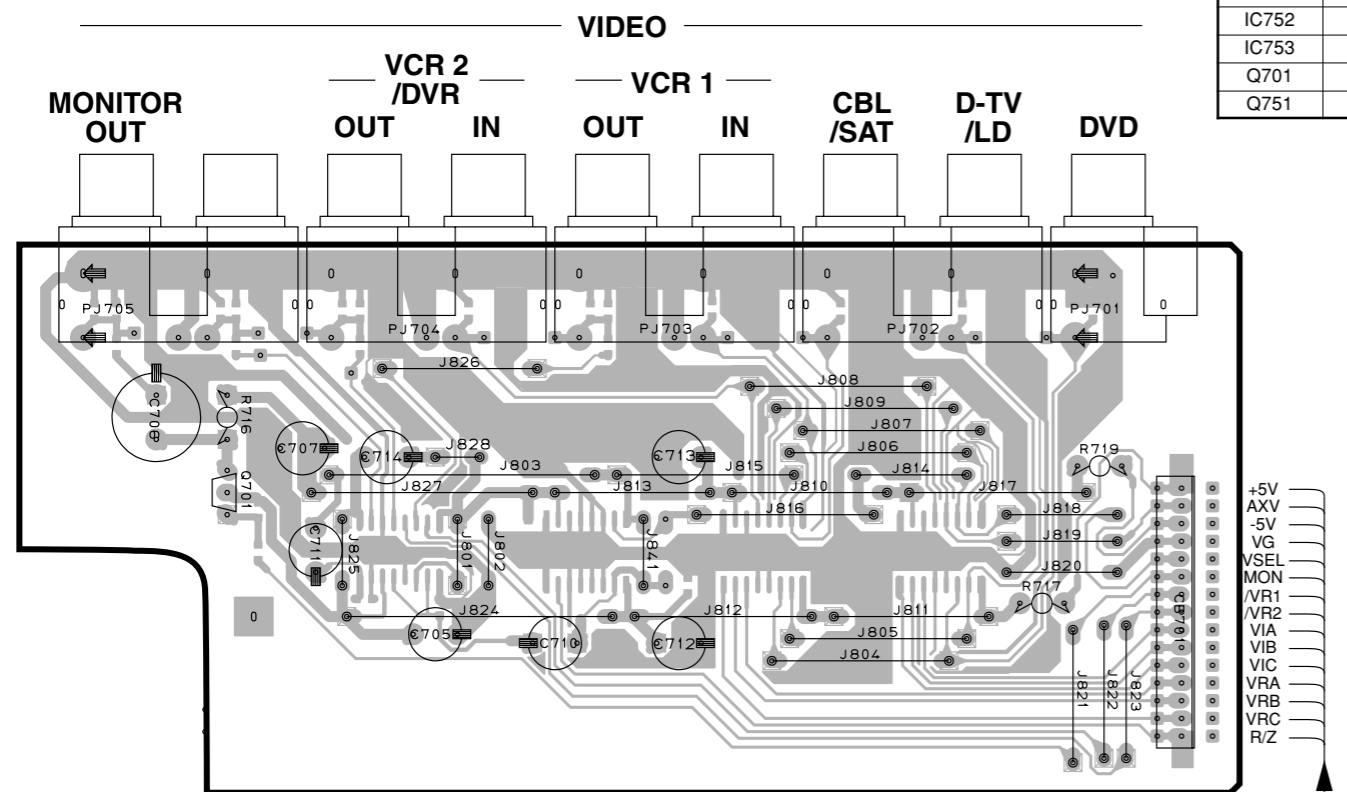

• Semiconductor Location

Ref. No.	Location
IC701	B6
IC702	D6
IC751	G6
IC752	G6
IC753	C6
Q701	A3
Q751	H4

**VIDEO (4) P. C. B.** (Lead Type Device)

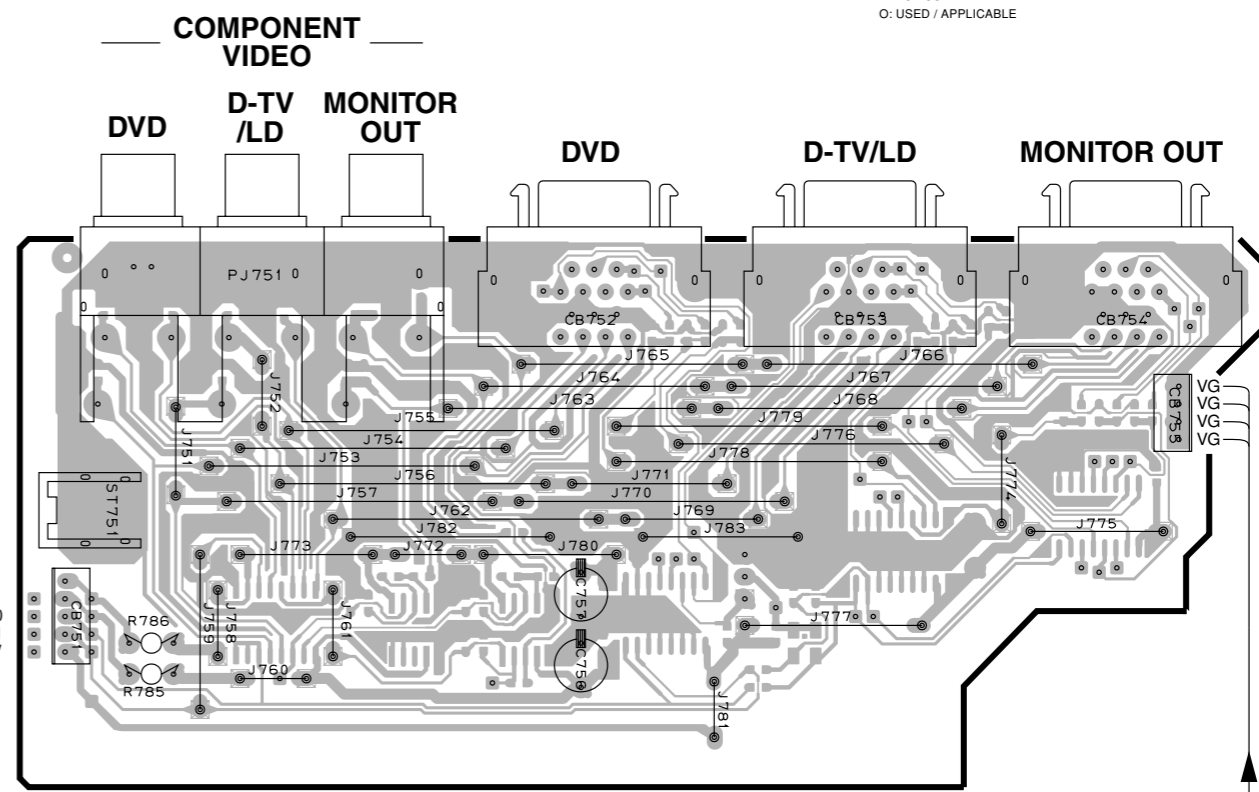

Circuit No.	J	U, C	R, T	A
C703, 711	X	O	O	O
C758-770	O	X	X	X
CB752-754	O	X	X	X
D751, 752	O	X	X	X
IC704	X	O	O	O
IC754-756	O	X	X	X
JB41	O	X	X	X
Q751	O	X	X	X
R711, 712	X	O	O	O
R772-784	O	X	X	O

X: NOT USED  
O: USED / APPLICABLE

From VIDEO (5)

From VIDEO (5)

From VIDEO (8)

**VIDEO (2) P. C. B.** (Surface Mount Device)

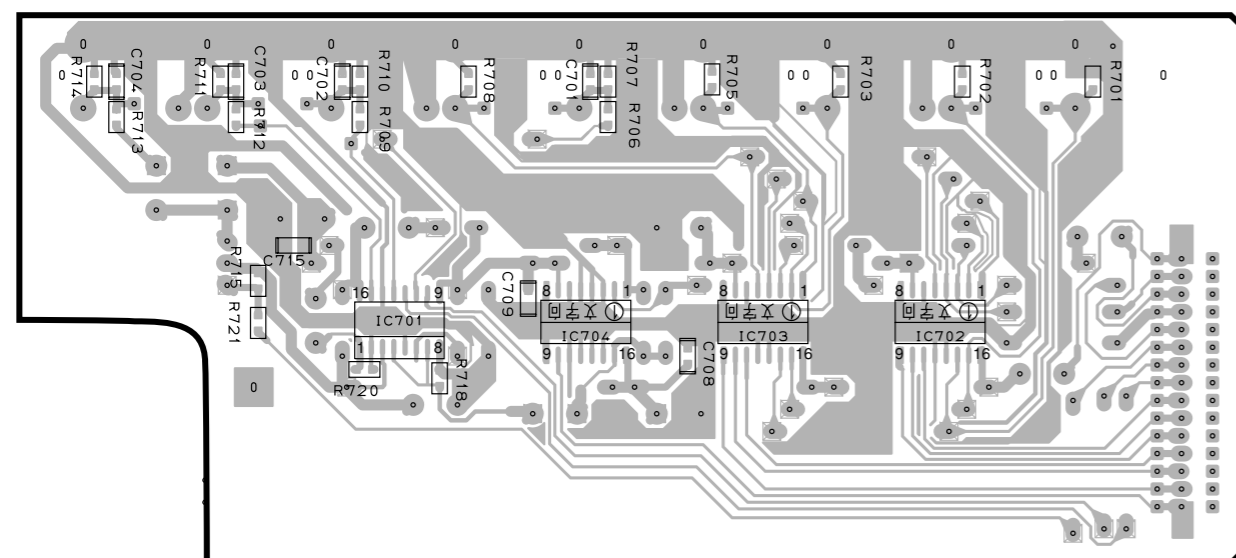

**VIDEO (4) P. C. B.** (Surface Mount Device)

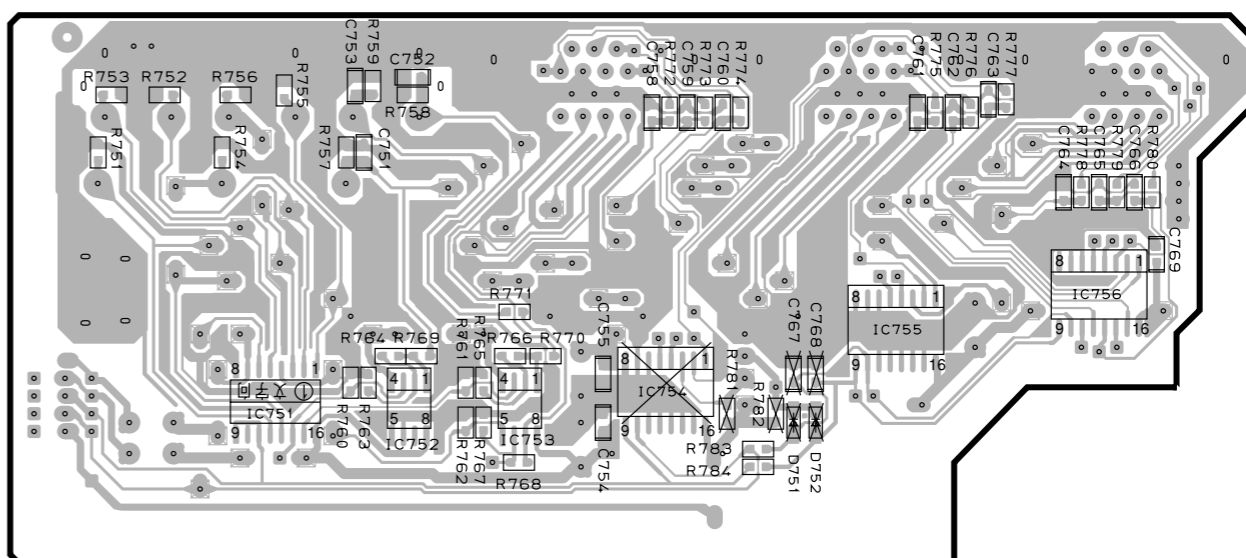

Production of the parts marked with "x" has been discontinued starting with November production of 2001.  
x マークの付いた部品は、2001年11月生産分より廃止されています。

1 ■ RX-V2200/DSP-AX2200 PRINTED CIRCUIT BOARD (Foil side)

Circuit No.	J	U, C	R, T	A
R583	X	O	O	X
R584	O	X	X	O
R585	X	X	O	O
R586	O	O	X	X
R589	X	O	O	O

X: NOT USED  
 O: USED / APPLICABLE

2 VIDEO (5) P. C. B. (Lead Type Device)

3 VIDEO (5) P. C. B. (Surface Mount Device)

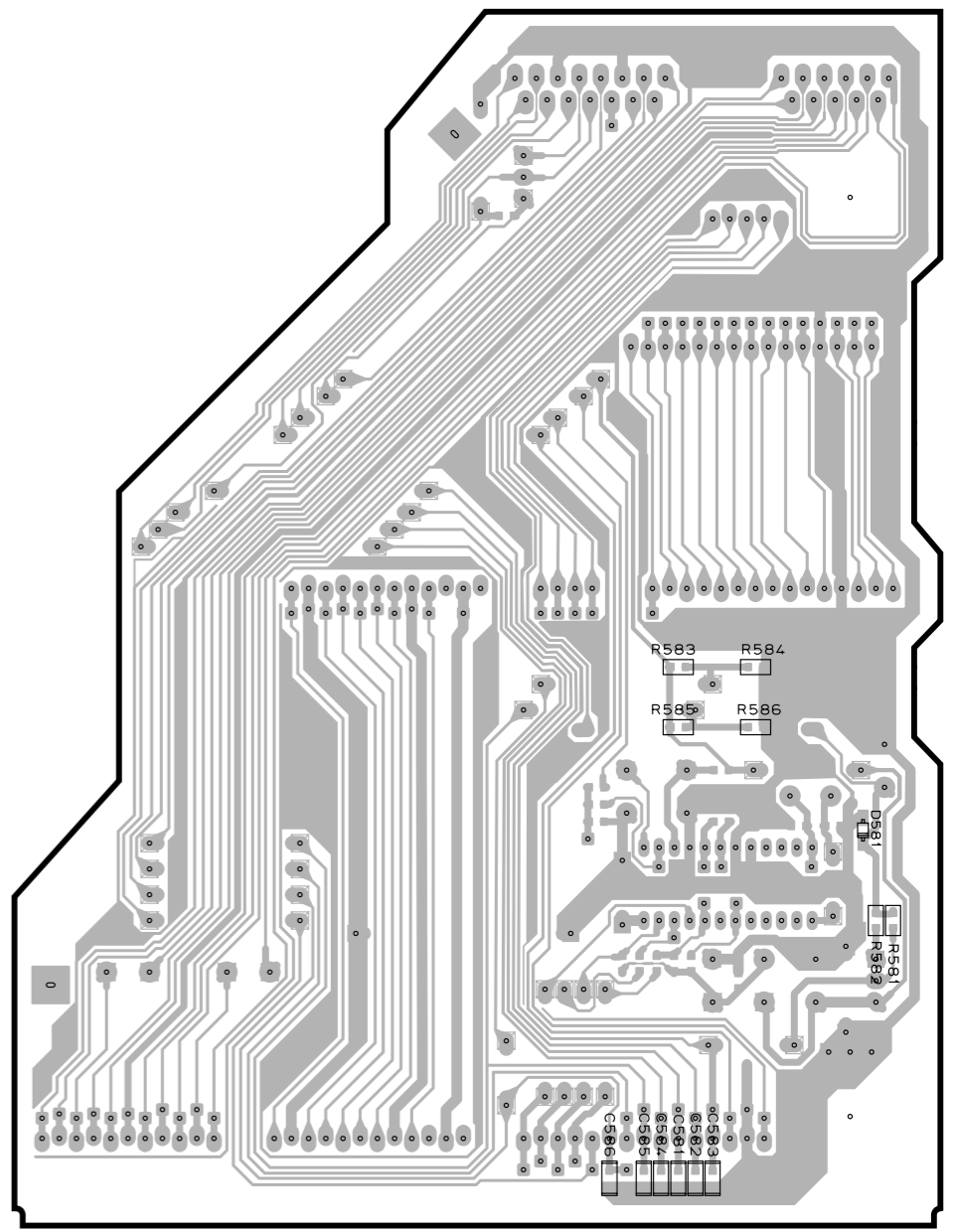
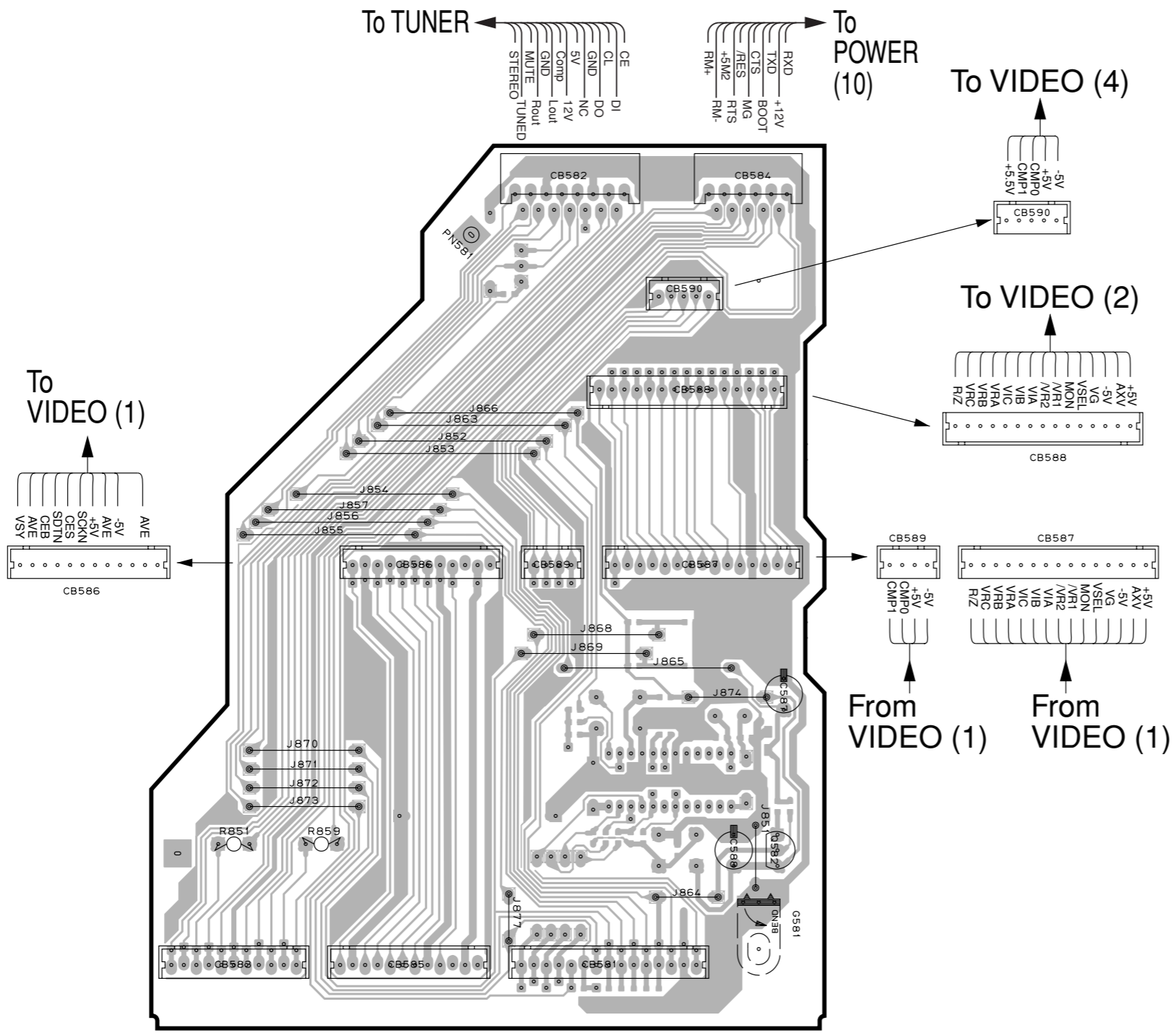

7 • Semiconductor Location

Ref. No.	Location
D581	J5
Q582	E6

**RX-V2200/DSP-AX2200 PRINTED CIRCUIT BOARD (Foil side)**

**VIDEO (6) P. C. B.** (Lead Type Device)

**VIDEO (6) P. C. B.** (Surface Mount Device)

**VIDEO (7) P. C. B.** (Lead Type Device)

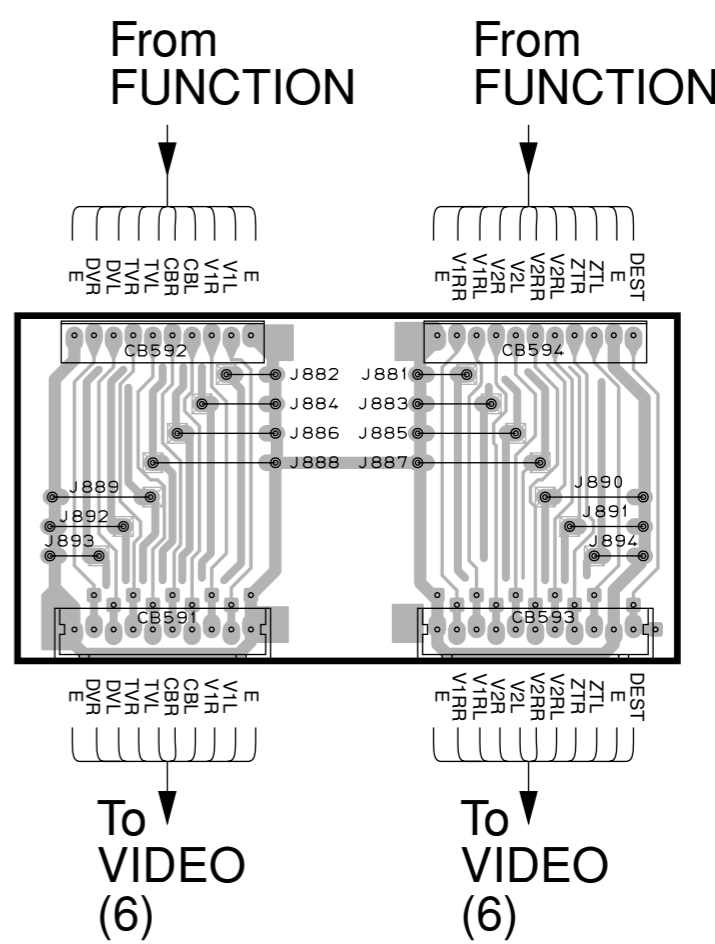
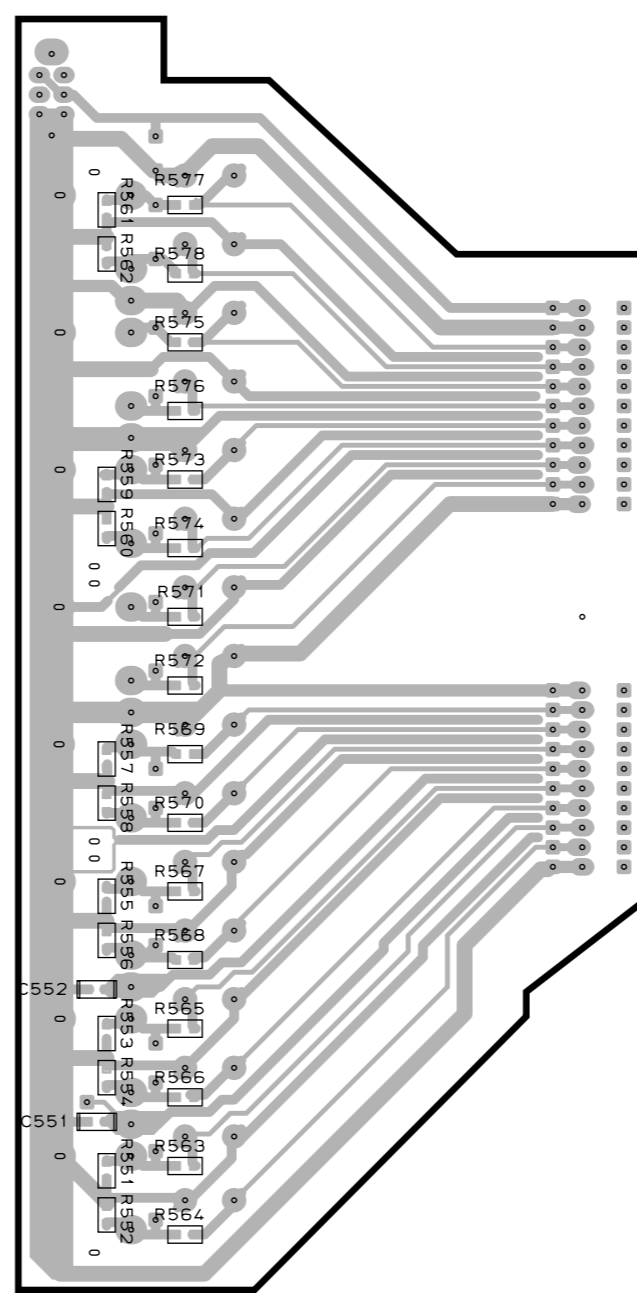
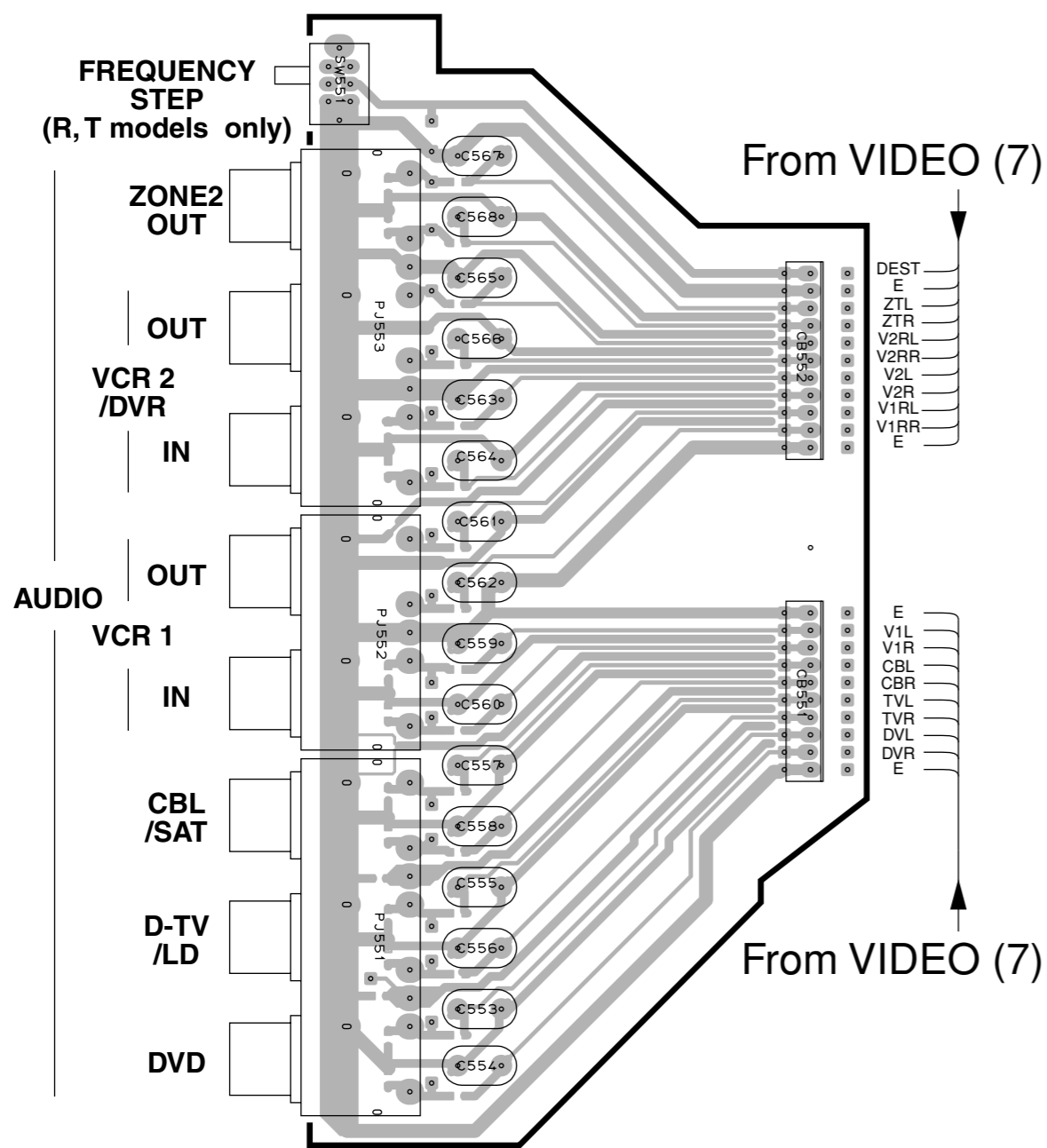

**VIDEO (8) P. C. B.** (Lead Type Device)

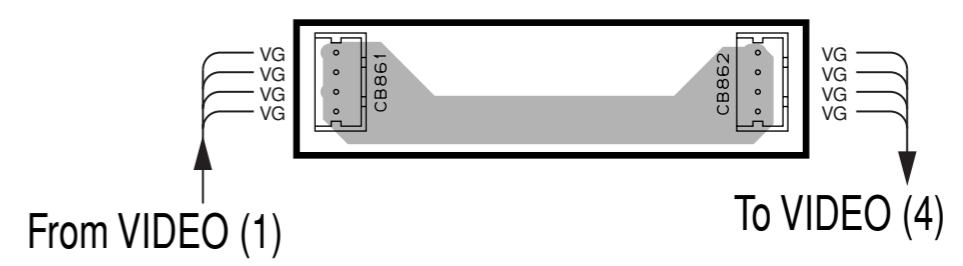

Circuit No.	J	U.C	R,T	A
C567, 568	X	O	O	O
R561, 562, 577, 578	X	O	O	O
SW551	X	X	O	X

X: NOT USED  
O: USED / APPLICABLE

1 ■ PRINTED CIRCUIT BOARD (Foil side)

• Semiconductor Location

Ref. No.	Location	Ref. No.	Location	Ref. No.	Location	Ref. No.	Location	Ref. No.	Location	Ref. No.	Location	Ref. No.	Location	Ref. No.	Location
D1	H6	D8	H3	D16	B5	Q5	E2	Q12	H3	Q19A	F2	Q25C	B2	Q33	B3
D2	G3	D9	I3	D18	B6	Q6	I5	Q13	E3	Q19C	G2	Q27A	C2	Q34	D3
D3	H3	D10	F3	D22	A4	Q7	B2	Q14	E3	Q21A	H2	Q27C	D2	Q35	A5
D4	I6	D11	B3	Q1	I5	Q8	D2	Q15	B3	Q21C	I2	Q29	B5	Q37	H5
D5	E3	D12	D3	Q2	I6	Q9	G3	Q16	A3	Q23A	E2	Q30	H3	Q40	B5
D6	A4	D13	A4	Q3	G2	Q10	F3	Q17	C3	Q23C	F2	Q31	I5	Q43	B5
D7	C3	D14	A4	Q4	H2	Q11	I3	Q18	C3	Q25A	B2	Q32	F3		

MAIN (1) P. C. B. (Lead Type Device)

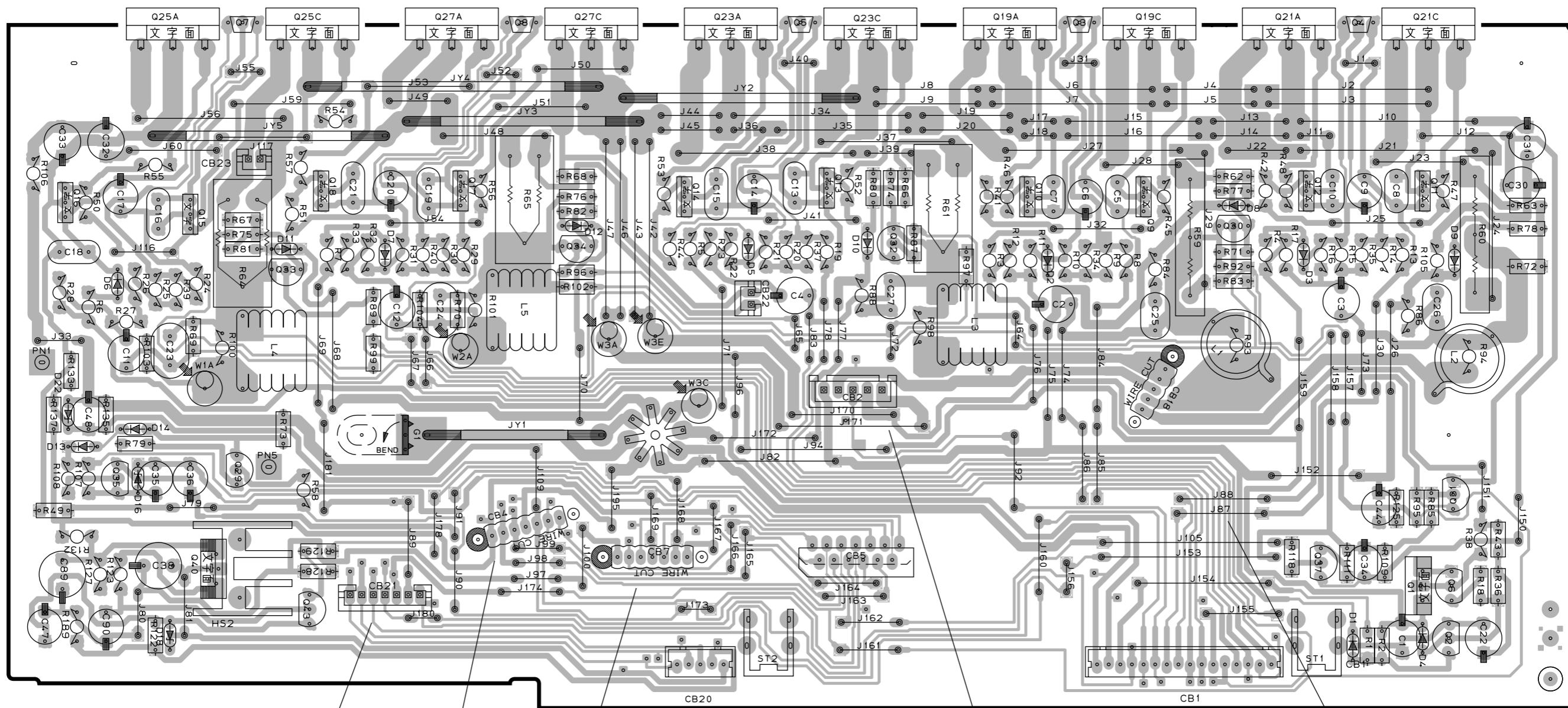

Circuit No.	RX-V1200/RX-V1200RDS/HTR-5490/DSP-AX1200	RX-V2200/DSP-AX2200
	J U C R T K A B G	J U C R T A
C38, 47, 89, 90	X X	X X
C57, 61, 64-66, 68	X X	X X
C75-82,		
D18	X X	X X
Q40, 43	X X	X X
R122, 123,	X X	X X
R127-129, 132, 189		
SW1	X O	X O
W11-14	X O	X O

X: NOT USED  
 O: USED / APPLICABLE

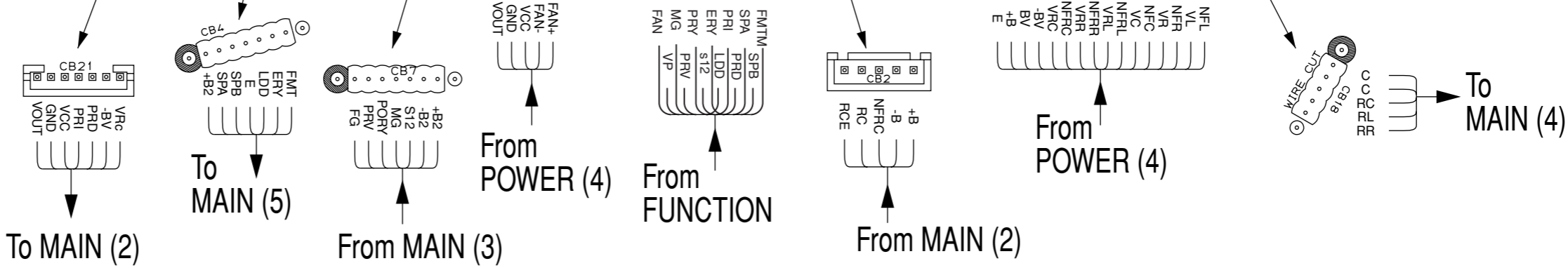

PRINTED CIRCUIT BOARD (Foil side)

MAIN (2) P. C. B. (Lead Type Device)

MAIN (3) P. C. B. (Lead Type Device)

MAIN (4) P. C. B. (Lead Type Device)

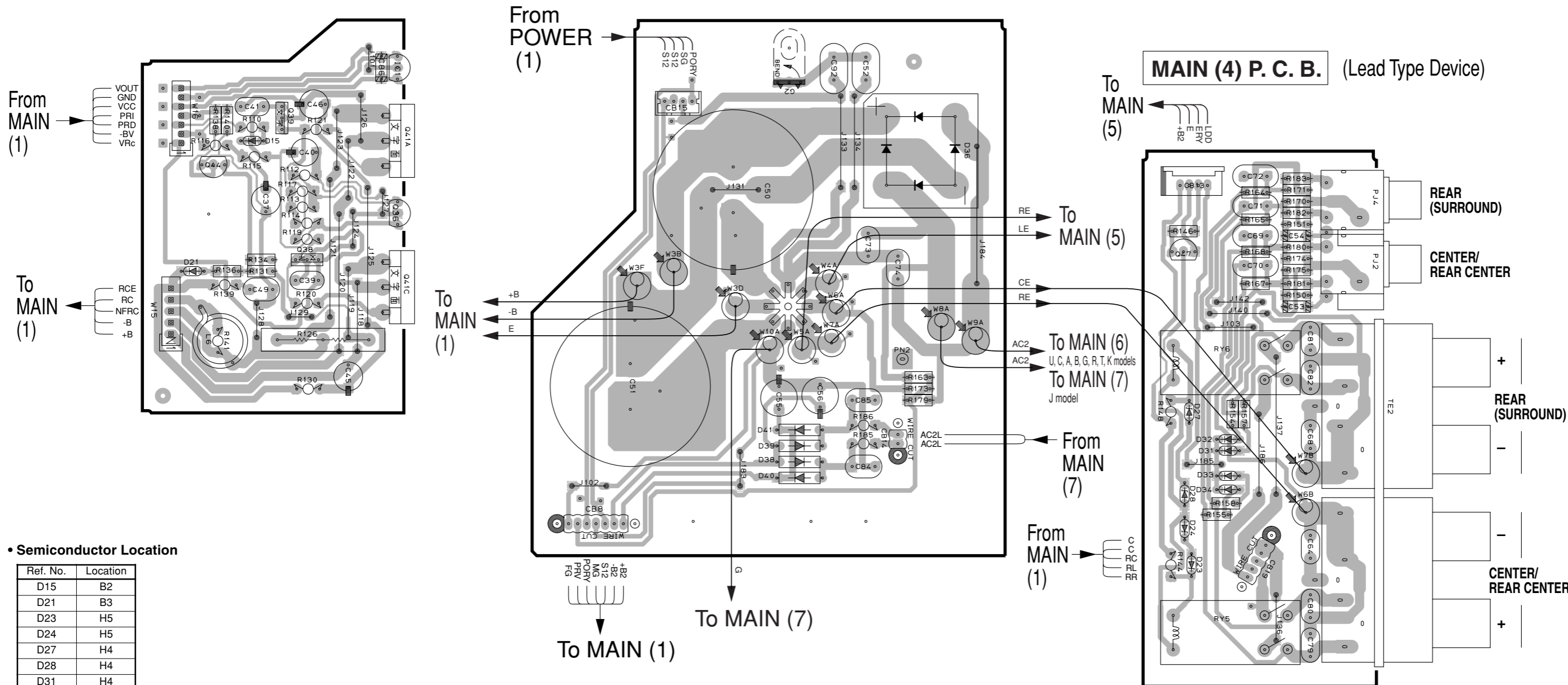

Semiconductor Location

Ref. No.	Location
D15	B2
D21	B3
D23	H5
D24	H5
D27	H4
D28	H4
D31	H4
D32	H4
D33	H4
D34	H4
D36	F2
D38	E4
D39	E4
D40	E4
D41	E4
IC1	C2
Q36	C3
Q38	C3
Q39	B2
Q40, 43	X X
R122, 123	X X
R127-129, 132, 189	X X
SW1	X O
W11-14	X O
Q44	B3
Q47	H3

Circuit No.	RX-V1200/RX-V1200RDS/HTR-5490/DSP-AX1200					RX-V2200/DSP-AX2200				
	J	U	C	R	T, K, A, B, G	J	U	C	R	T, A
C38, 47, 89, 90	X	X			O	O	O	O		
C57, 61, 64-66, 68	X	X			O	X	X	O		
C75-82										
D18	X	X			O	O	O	O		
Q40, 43	X	X			O	O	O	O		
R122, 123	X	X			O	O	O	O		
R127-129, 132, 189	X	X			O	O	O	O		
SW1	X	O			O	X	O	O		
W11-14	X	O			O	X	O	O		

X: NOT USED  
O: USED / APPLICABLE



1 ■ PRINTED CIRCUIT BOARD (Foil side)

2 **MAIN (5) P. C. B.** (Lead Type Device)

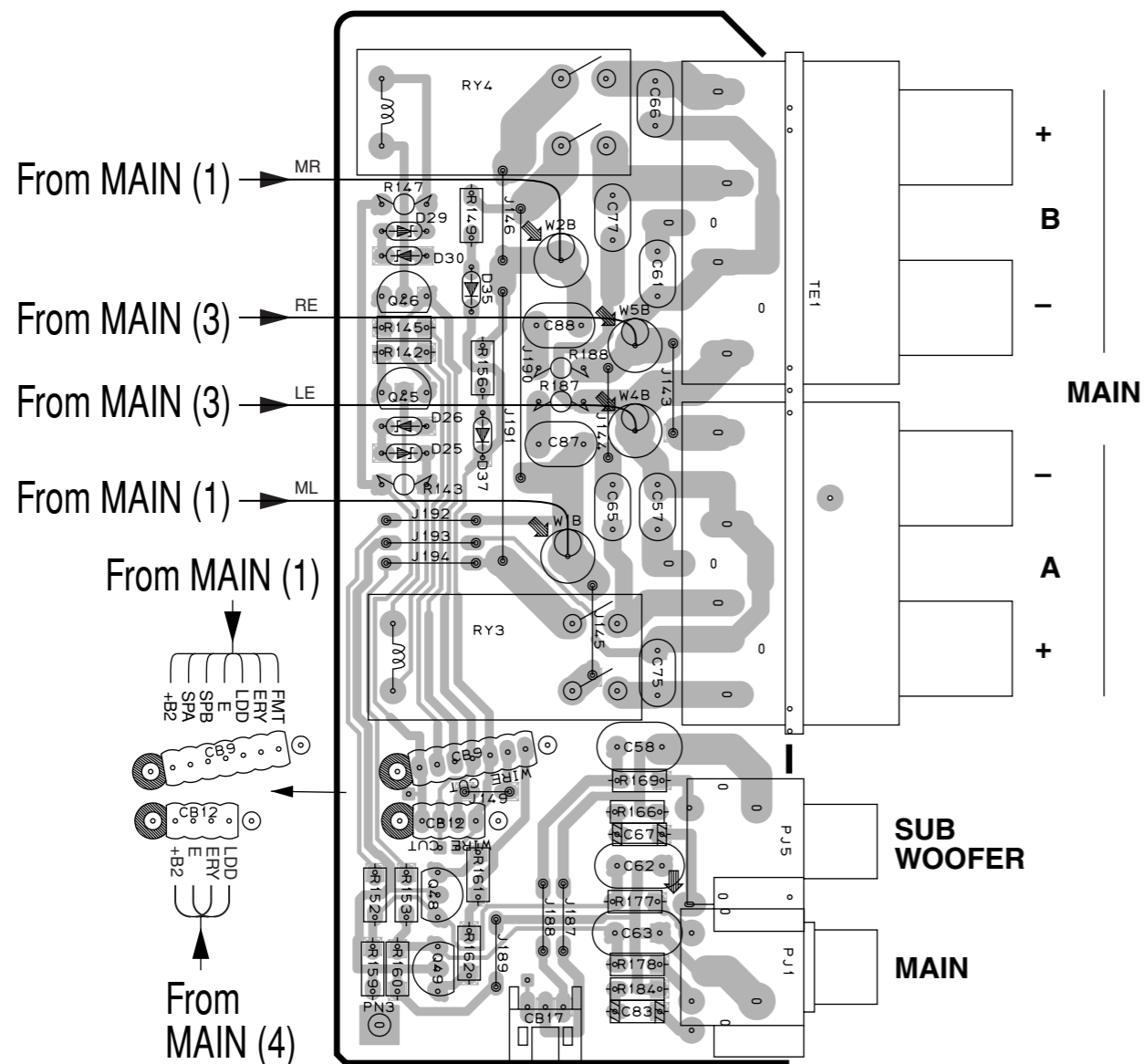

3 **MAIN (6) P. C. B.** (Lead Type Device)

U, C, A, B, G, R, T, K models

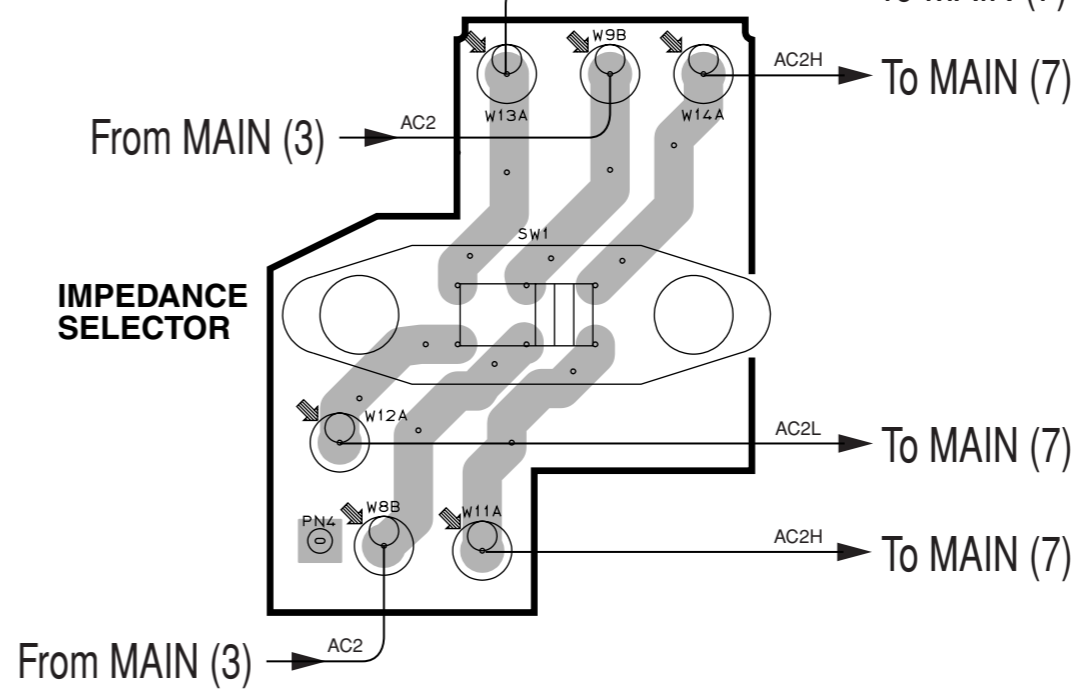

4 **MAIN (7) P. C. B.** (Lead Type Device)

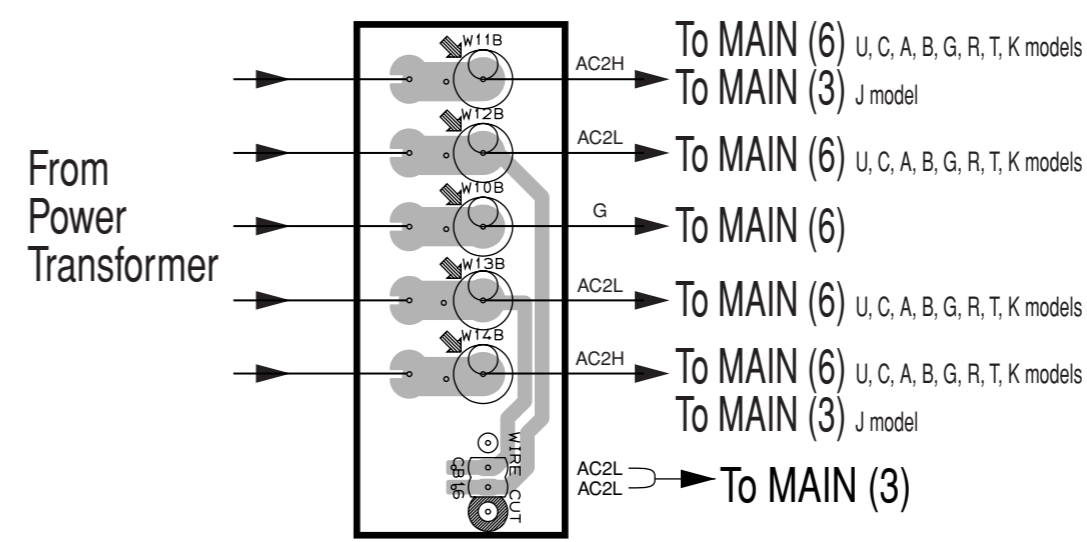

5 • Semiconductor Location

Ref. No.	Location
D25	B3
D26	B3
D29	B2
D30	B3
D35	B3
D37	B3
Q45	B3
Q46	B3
Q48	B5
Q49	B5

Circuit No.	RX-V1200/RX-V1200RDS/HTR-5490/DSP-AX1200					RX-V2200/DSP-AX2200				
	J	U	C	R	T, K, A, B, G	J	U	C	R	T, A
C38, 47, 89, 90	X	X			O	O	O	O		
C57, 61, 64-66, 68 C75-82,	X	X			O	X	X	O		
D18	X	X			O	O	O	O		
Q40, 43	X	X			O	O	O	O		
R122, 123, R127-129, 132, 189	X	X			O	O	O	O		
SW1	X	O			O	X	O	O		
W11-14	X	O			O	X	O	O		

X: NOT USED  
O: USED / APPLICABLE

PRINTED CIRCUIT BOARD (Foil side)

POWER (1) P. C. B. (Lead Type Device)

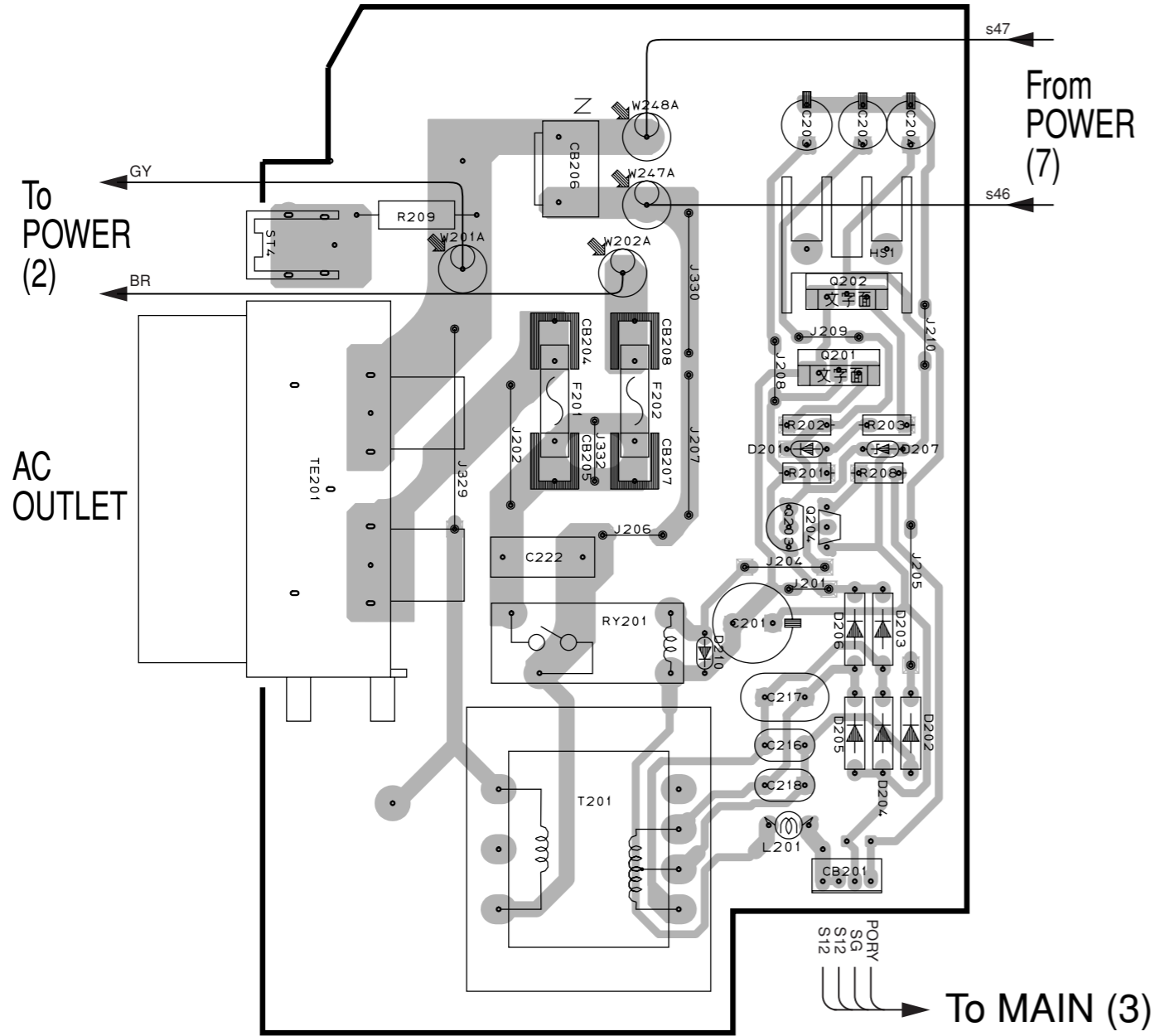

POWER (2) P. C. B. (Lead Type Device)

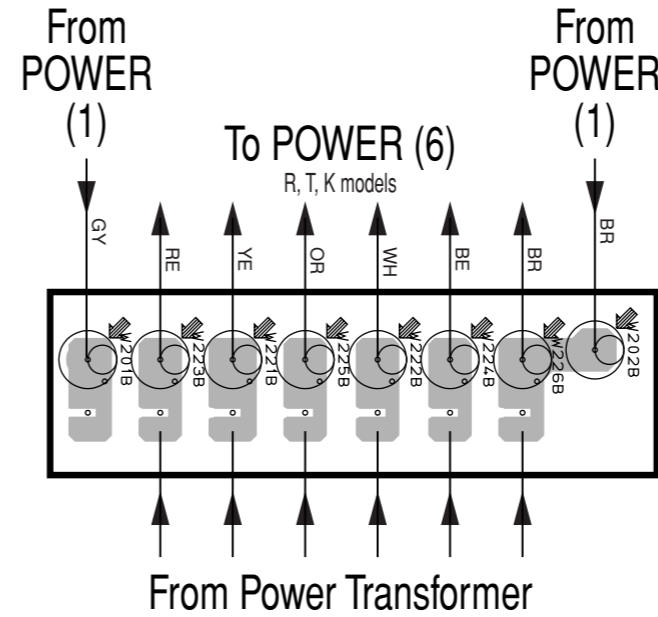

• Semiconductor Location

Ref. No.	Location
D201	D3
D202	D4
D203	D4
D204	D4
D205	D4
D206	D4
D207	D3
D208	I5
D209	J5
D210	D4
Q201	D3
Q202	D3
Q203	D4
Q204	D4

POWER (3) P. C. B. (Lead Type Device)

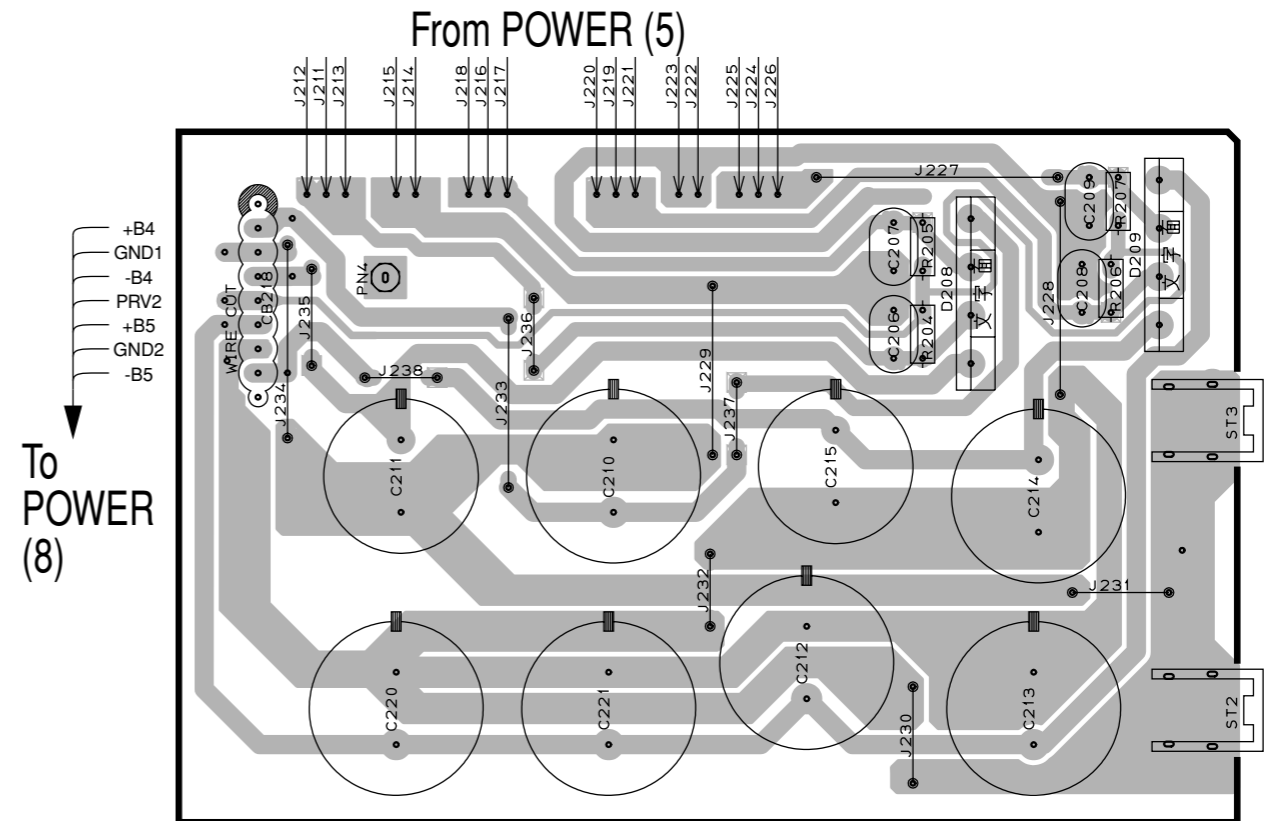

Circuit No.	RX-V1200/RX-V1200RDS/HTR-5490/DSP-AX1200										RX-V2200/DSP-AX2200																				
	J	U	C	R	T	K	A	B	G	J	U	C	R	T	A	J	U	C	R	T	A										
C202-204, 216, 218	X	X	X	X	O	X	X	X	X	X	X	X	X	O	X	X	X	X	X	X	X	X	X	X	X	X	X	X	X	X	
C217	O	O	O	X	O	O	O	O	O	O	O	O	O	O	X	O	O	O	O	X	O	O	O	O	O	O	O	O	O	X	O
CB204, 205	X	O	X	X	X	X	X	X	X	O	X	O	X	X	X	X	O	X	X	X	X	X	X	O	X	X	X	X	X	X	
CB206	O	X	X	O	O	O	O	O	O	O	X	X	X	O	O	O	X	X	O	O	O	O	O	O	X	X	X	O	O		
CB217	X	O	O	X	X	X	X	X	O	O	O	O	X	X	X	O	O	X	X	X	X	X	O	O	O	X	X				
D201, 202, 207	X	X	X	O	X	X	X	X	X	X	X	X	X	O	X	X	X	X	O	X	X	X	X	X	X	X	O	X			
F201	X	O	X	X	X	X	X	O	X	O	X	O	X	X	X	O	X	X	X	X	X	O	X	O	X	X					
J201	O	O	O	X	O	O	O	O	O	O	O	O	O	X	O	O	O	O	X	O	O	O	O	O	O	O	X				
J202	O	X	O	O	O	O	X	O	X	O	X	O	O	O	O	X	O	O	O	X	O	X	O	O	O						
Q201-203	X	X	X	O	X	X	X	X	X	X	X	X	X	O	X	X	X	X	O	X	X	X	X	X	X	O	X				
R201-203	X	X	X	O	X	X	X	X	X	X	X	X	X	O	X	X	X	X	O	X	X	X	X	X	X	O	X				
R209	X	O	O	X	X	X	X	X	X	O	O	X	X	X	O	O	X	X	X	X	X	O	O	X	X						
W221-226	X	X	X	O	X	X	X	X	X	X	X	X	X	O	X	X	X	X	O	X	X	X	X	X	X	O	X				
W247, 248	X	O	O	X	X	X	X	X	O	O	O	O	X	X	X	O	O	X	X	X	X	O	O	O	X	X					

X: NOT USED  
O: USED / APPLICABLE

1 ■ PRINTED CIRCUIT BOARD (Foil side)

Circuit No.	RX-V1200/RX-V1200RDS/HTR-5490/DSP-AX1200					RX-V2200/DSP-AX2200						
	J	U	C	R, T, K	A	B	G	J	U	C	R, T	A
C242	X	O	O	O	O	O	O	X	O	O	O	O
CB209, 210	X	X	X	O	X	X	X	X	X	X	O	X
CB216	X	X	X	O	O	O	O	O	O	O	O	O
D213	X	O	O	O	O	O	O	X	O	O	O	O
F203	X	X	X	O	X	X	X	X	X	X	O	X
Q206	X	O	O	O	O	O	O	X	O	O	O	O
R228, 229	X	O	O	O	O	O	O	X	O	O	O	O
SW202	X	X	X	O	X	X	X	X	X	X	O	X
W221-226	X	X	X	O	X	X	X	X	X	X	O	X
W247, 248	X	O	O	X	X	X	X	O	O	O	X	X

X: NOT USED  
O: USED / APPLICABLE

• Semiconductor Location

Ref. No.	Location
D211	D3
D212	C3
D213	C3
D214	D3
D215	C3
D216	C6
D217	C6
Q205	C3
Q206	C3
Q207	C6
Q208	C6
Q209	C5
Q210	C5
Q211	C4
Q212	C4
Q213	C3
Q214	D6
Q215	C6
Q216	D6
Q217	C6
Q218	D5
Q219	C5
Q220	D5
Q221	C5
Q222	D4
Q223	C4
Q224	D4
Q225	C4

2 POWER (4) P. C. B. (Lead Type Device)

POWER (5) P. C. B. (Lead Type Device)

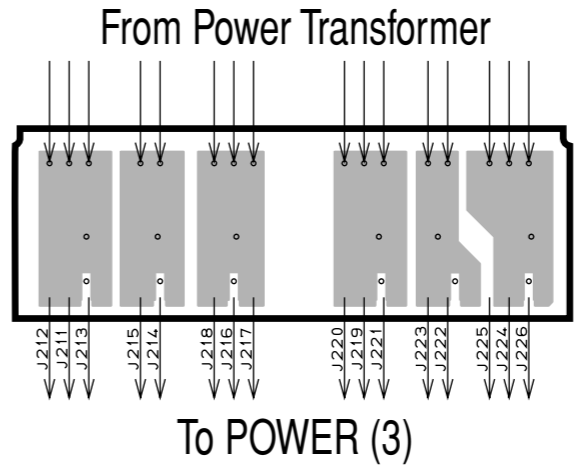
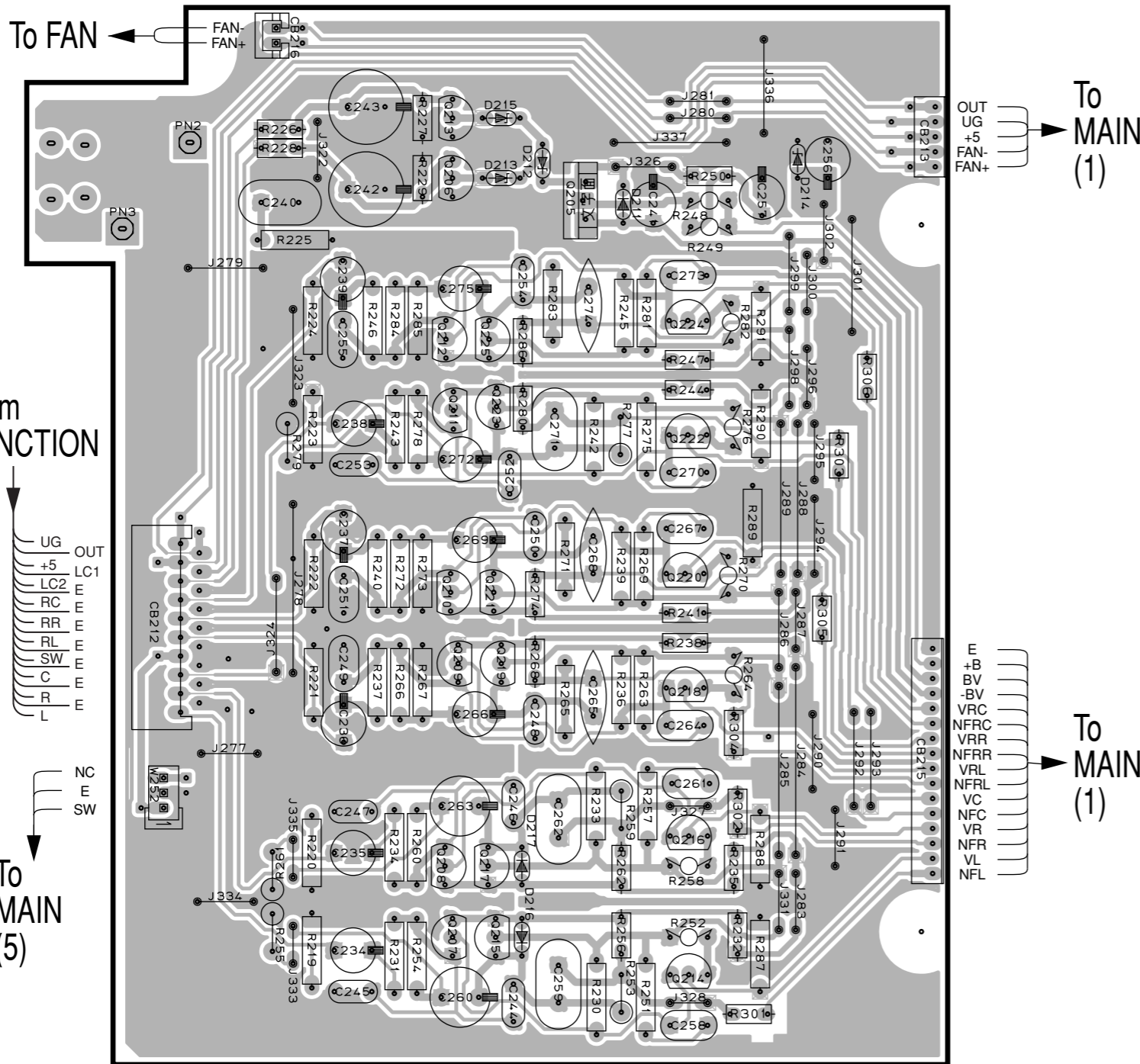

POWER (6) P. C. B. (Lead Type Device)

R, T, K models

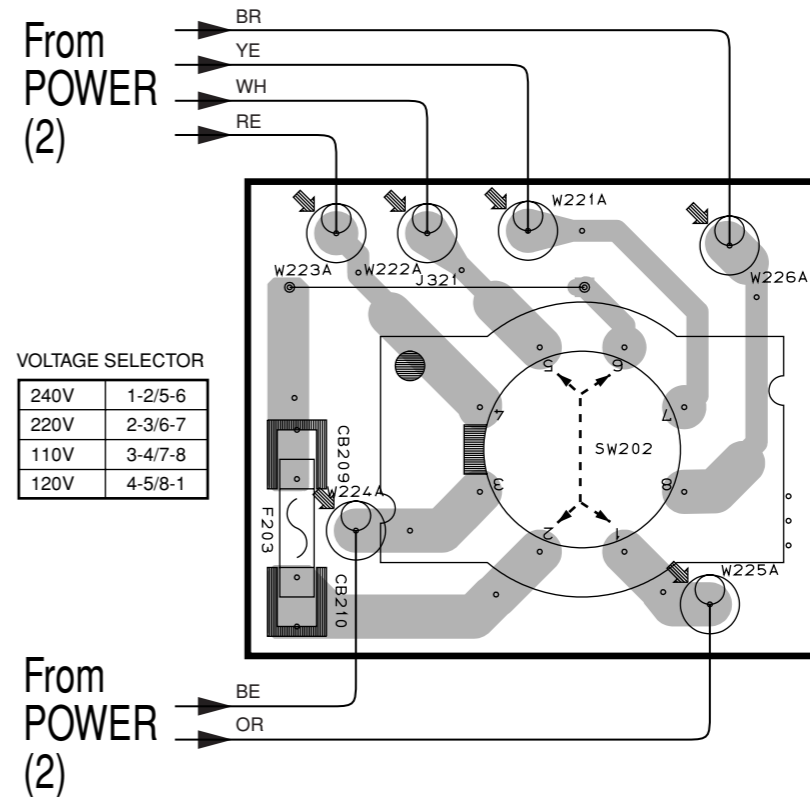

1 ■ PRINTED CIRCUIT BOARD (Foil side)

POWER (7) P. C. B. (Lead Type Device)

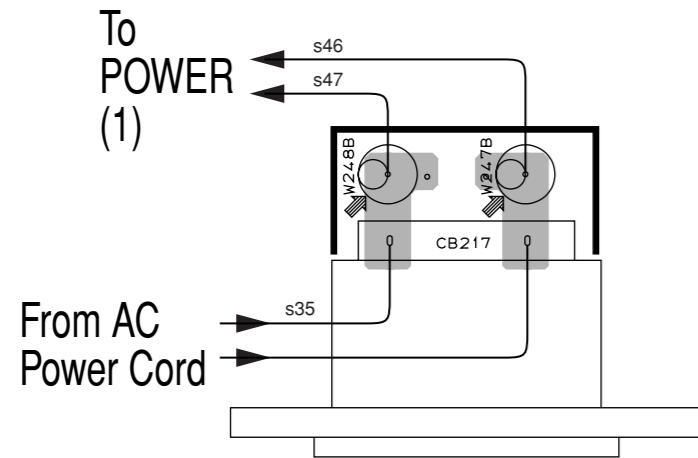

POWER (8) P. C. B. (Lead Type Device)

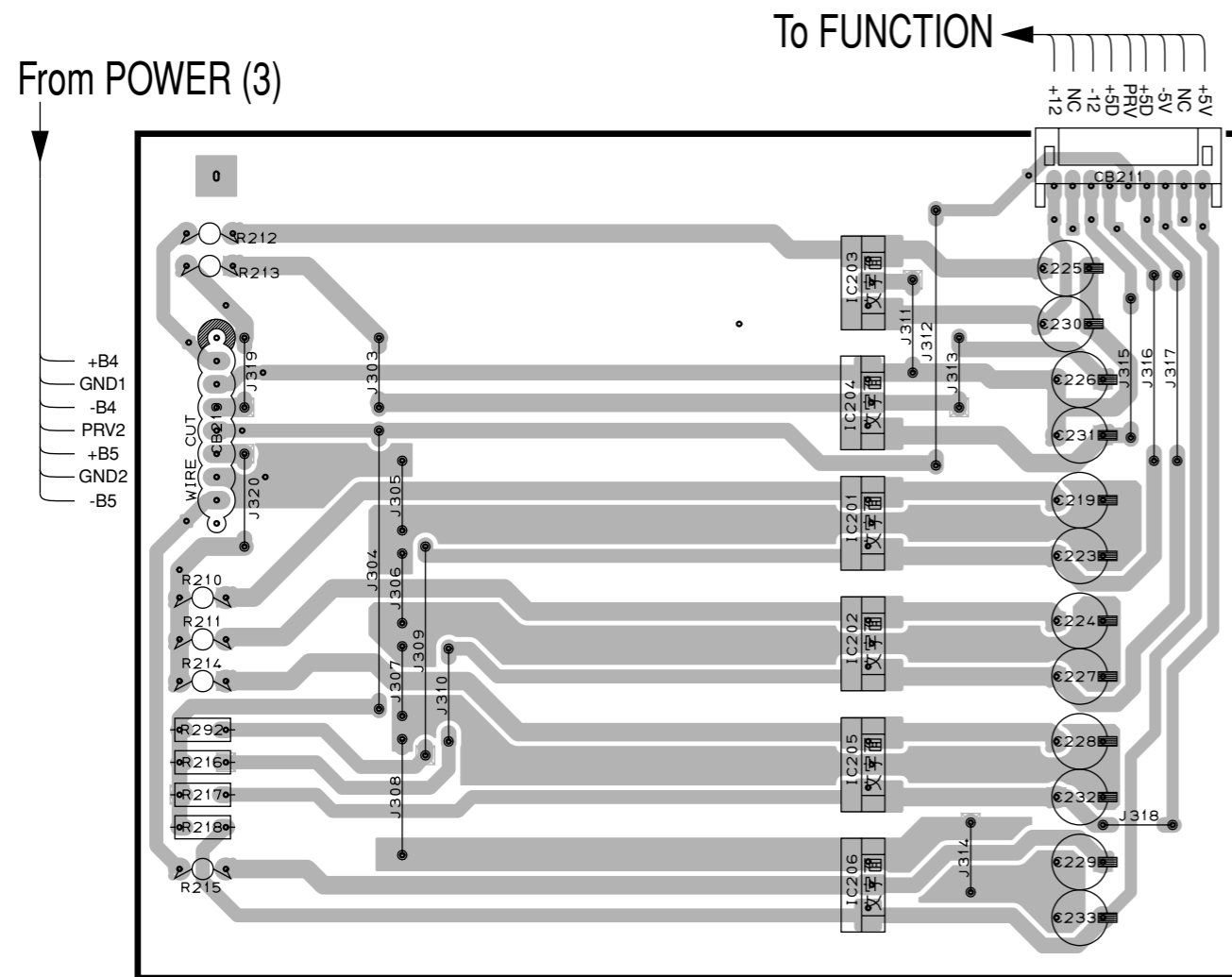

POWER (10) P. C. B. (Lead Type Device)

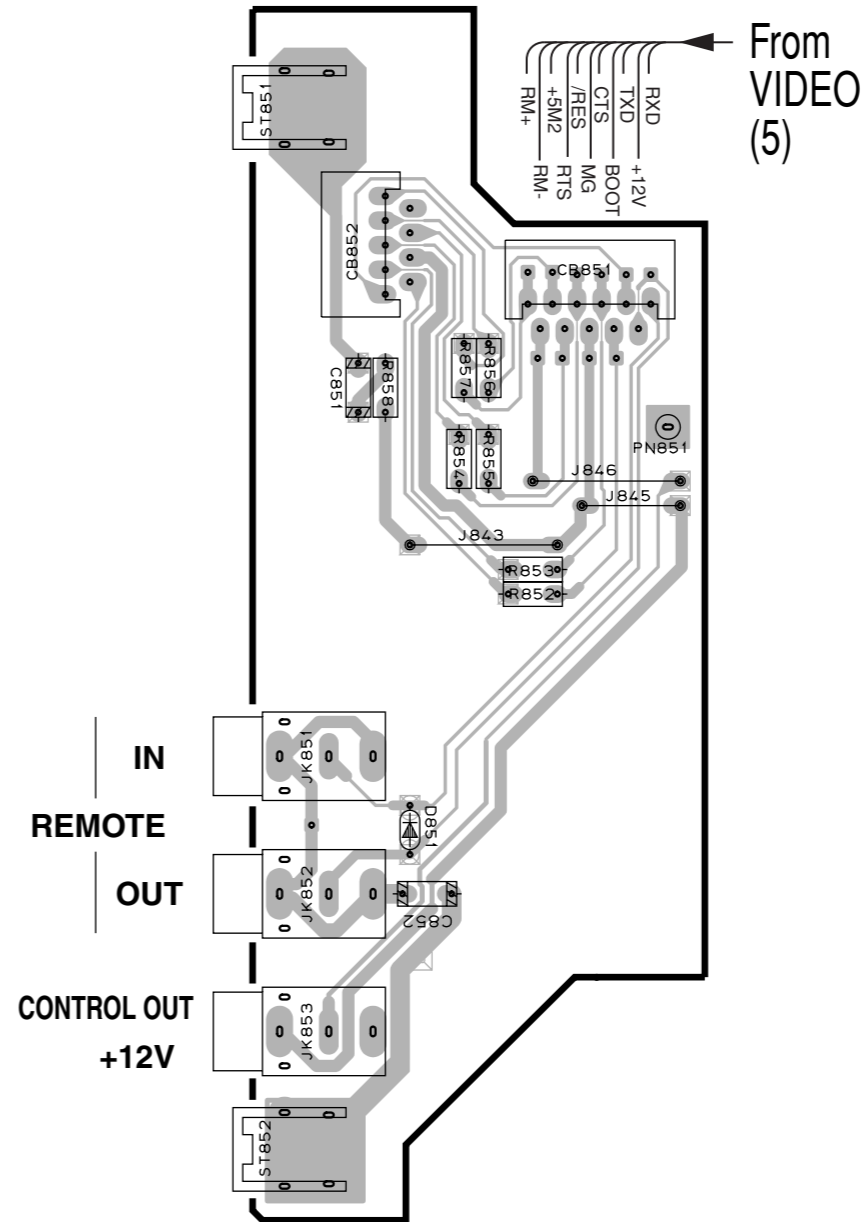

• Semiconductor Location



Ref. No.	Location
D851	G4
IC201	D6
IC202	D6
IC203	D5
IC204	D5
IC205	D6
IC206	D7

Circuit No.	RX-V1200/RX-V1200RDS/HTR-5490/DSP-AX1200					RX-V2200/DSP-AX2200					
	J	U	C	R, T, K	A	B	G	J	U	C	R, T, A
C852	X	O	O	X	O	X	X	X	O	O	O
D851	X	O	O	X	O	X	X	X	O	O	O
JK851-853	X	O	O	X	O	X	X	X	O	O	O
W221-226	X	X	X	O	X	X	X	X	X	X	O
W247, 248	X	O	O	X	X	X	X	O	O	O	X

X: NOT USED  
O: USED / APPLICABLE

# PIN CONNECTION DIAGRAM

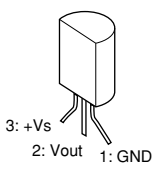
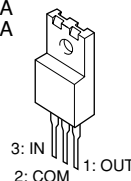
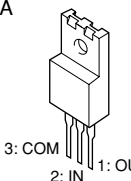
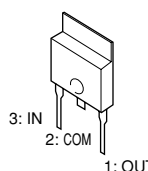
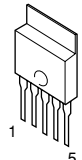
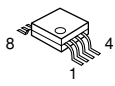
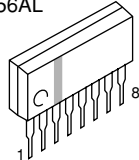
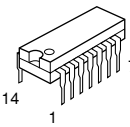
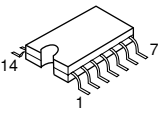
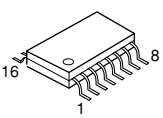
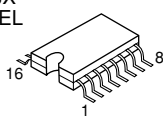
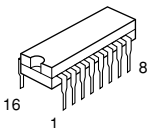
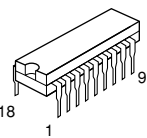
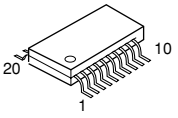
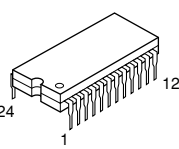
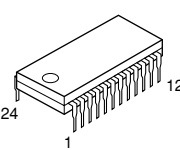
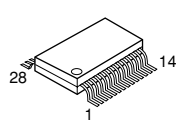
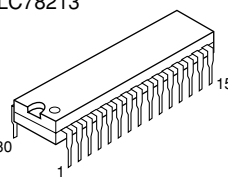
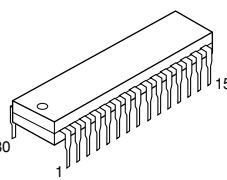
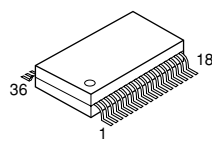
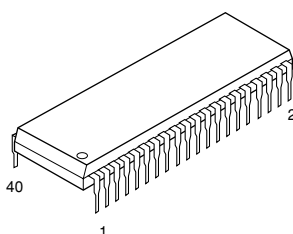
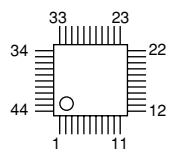
## • ICs

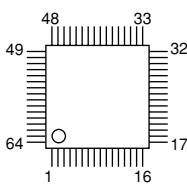
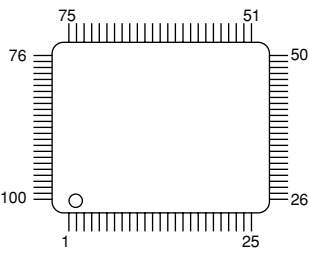
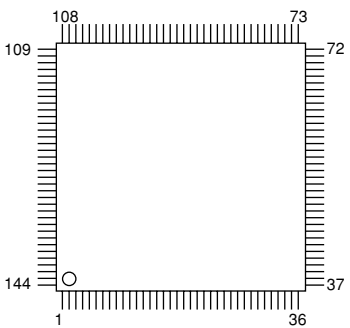
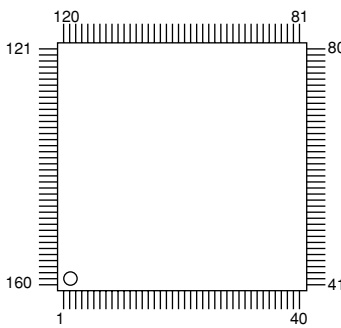
<p>LM61CIZ</p>  <p>3: +Vs 2: Vout 1: GND</p>	<p>NJM7805FA NJM78M05FA NJM78M12FA</p>  <p>3: IN 2: COM 1: OUT</p>	<p>NJM79M05FA NJM79M12FA</p>  <p>3: COM 2: IN 1: OUT</p>	<p>μPC29M33T-E1</p>  <p>3: IN 2: COM 1: OUT</p>	<p>PQ025EZ5MZP</p>  <p>1 5</p>
<p>NJM2068MD NJM2904M OPA2652U TK15420M μPC4570G2</p>  <p>8 1 4</p>		<p>NJM2068LD NJM4556AL</p>  <p>1 8</p>	<p>TC4066BP</p>  <p>14 1 7</p>	<p>TC74HCT00AF TC74HCT08AF TC74HCU04AF</p>  <p>14 1 7</p>
<p>LA7108M</p>  <p>16 1 8</p>	<p>MM74HC4051N MM74HC4051SJX MM74HC4053N MM74HC4053SJX TC74HC4051AFEL TC74HC4052AF</p>  <p>16 1 8</p>	<p>TC74HC4051AP TC74HC4053AP</p>  <p>16 1 8</p>	<p>BU2092</p>  <p>18 1 9</p>	<p>YAC520-EE2</p>  <p>20 1 10</p>
<p>LC72722</p>  <p>24 1 12</p>	<p>LC74781-9798</p>  <p>24 1 12</p>	<p>AK4393-VF-E2 CY62256LL</p>  <p>28 1 14</p>	<p>LC78211 LC78213</p>  <p>30 1 15</p>	<p>LC78212</p>  <p>30 1 15</p>
<p>LA7109</p>  <p>36 1 18</p>	<p>MSM514260C-60JS</p>  <p>40 1 20</p>		<p>AK4527BVQ</p>  <p>33 23 34 22 44 11 12</p>	<p>MBM29F400BC-70</p>  <p>25 48 1 24</p>
<p>LC75712E</p>  <p>48 33 49 32 64 17 1 16</p>	<p>XC9572XL-10TQ100C</p>  <p>75 51 76 50 100 26 1 25</p>	<p>M30802SGP</p>  <p>108 73 109 72 144 37 1 36</p>	<p>YSS938F</p>  <p>120 81 121 80 160 40 1 40</p>	



RX-V1200/RX-V1200RDS/HTR-5490/RX-V2200

RX-V1200/RX-V1200RDS/HTR-5490/RX-V2200

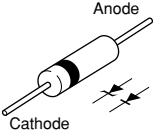
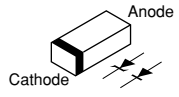
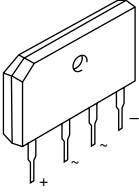
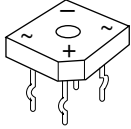
• Diodes

<p>1SR139 1SS133 1SS270A 1T2 HZS7B2TD</p>	<p>MTZJ4.7C MTZJ9.1A MTZJ11.0B MTZJ12.0A MTZJ12.0C MTZJ15.0B MTZJ20.0A MTZJ24.0C MTZJ33.0B</p>		<p>1SS355 1SS380 MA8051-M MA8056-L MA8056-M MA8062-H RB501V-40 UDZS5.6BTE-17</p>	
<p>D2SBA20</p> 	<p>S5VB20</p> 			

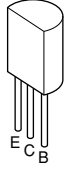
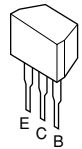
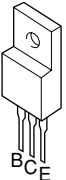
• Transistors

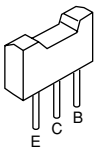
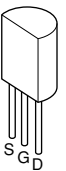
<p>2SA893A 2SA970 2SA1015 2SB949 2SC535 2SC1815 2SC1890A 2SC2240 2SC2878</p> 	<p>2SA933S 2SC1740S 2SD1915F 2SD1991A DTA144ES DTC114ES DTC144ES</p> 	<p>2SB941 2SB1565 2SD2396</p> 	<p>2SA1492 2SA1695 2SC3856 2SC4468</p> 
<p>2SA1037K 2SC3326 DTA144EKA DTC144EKA</p> 	<p>2SA1708 2SA1770 2SC4488 2SC4614</p> 	<p>2SK246</p> 	

# SCHEMATIC DIAGRAM (RX-V1200/RX-V1200RDS/HTR-5490/DSP-AX1200 FUNCTION)

RX-V1200/RX-V1200RDS/HTR-5490/DSP-AX1200/RX-V2200/DSP-AX2200

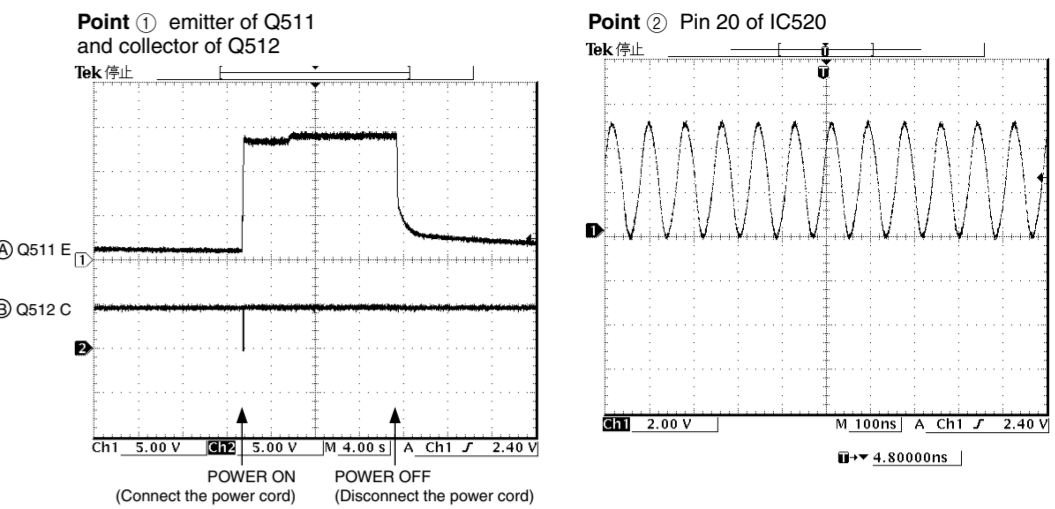
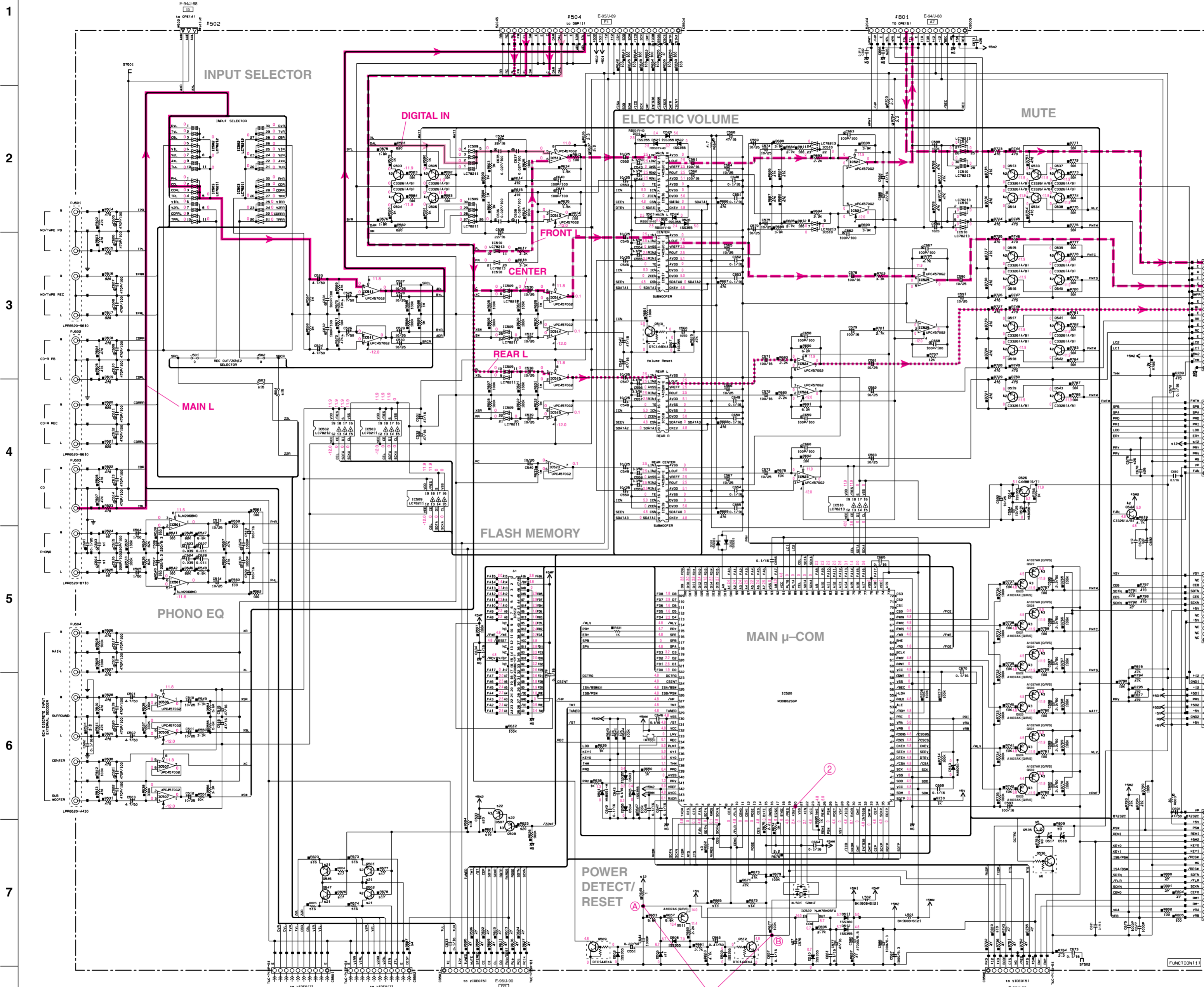

IC501: NJM2068MD	IC506, 507: 511, 513-515: μPC4570G2	IC521, IC523-IC525: μPC4570G2	Dual Op-Amp
OUT1 [1]	8 +Vcc	7 OUT2	
-IN1 [2]		6 -IN2	
+IN1 [3]		5 +IN2	
-Vcc [4]			

IC502: LC78212	IC510: LC78213
L1 [1]	R1 [1]
L2 [2]	R2 [2]
L3 [3]	R3 [3]
LOCM1 [4]	RCOM1 [4]
L4 [5]	R4 [5]
L5 [6]	R5 [6]
LOCM2 [7]	RCOM2 [7]
L6 [8]	R6 [8]
L7 [9]	R7 [9]
LOCM3 [10]	RCOM3 [10]
L8 [11]	R8 [11]
LOCM4 [12]	RCOM4 [12]
VDD [13]	LEVEL SHIFTER
VSS [14]	LATCH
VEE [15]	SHIFT REGISTER
RES [16]	CONTROL
S [17]	CE

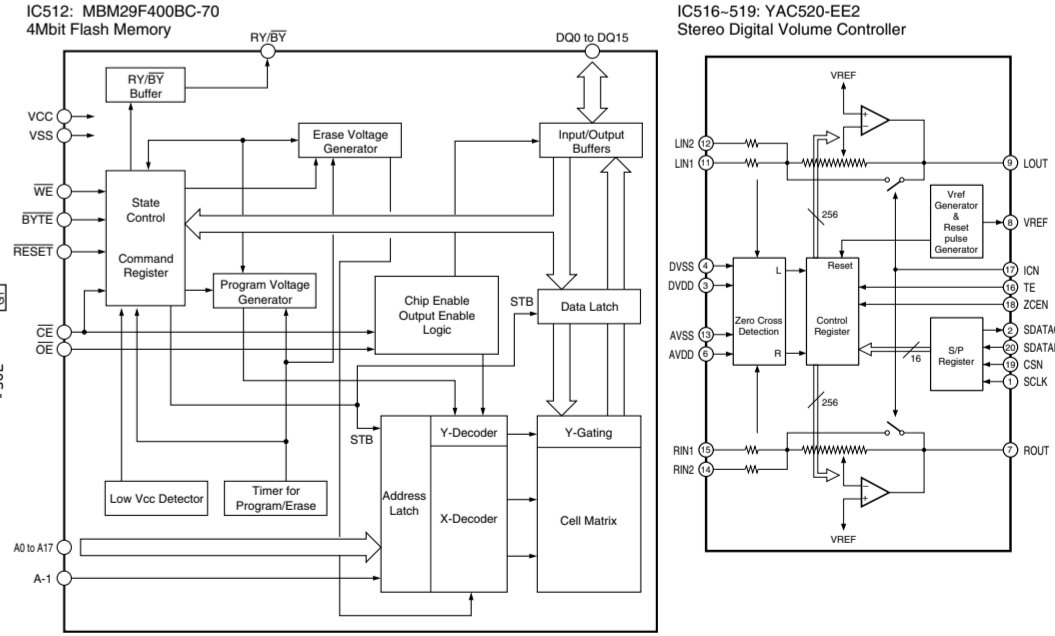
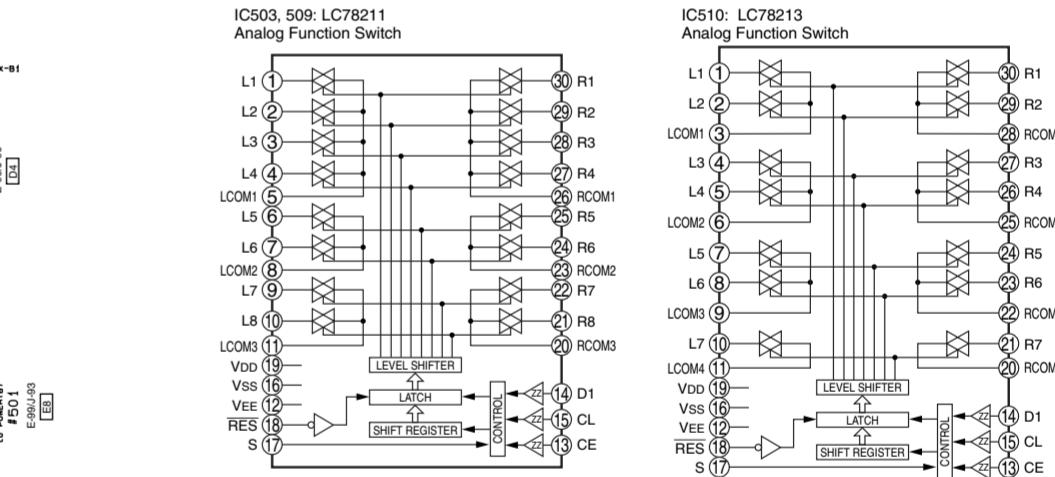

NOTICE (model 1)

Interchangeable Parts at Manufacturer's Stage

(J)..... JAPANESE  
(U)..... U.S.A  
(C)..... CANADIAN  
(B)..... GENERAL  
(A)..... AUSTRALIAN  
(E)..... BRITISH  
(D)..... EUROPEAN  
(T)..... CHINA  
(K)..... KOREA

REMARKS	PARTS NAME	REMARKS	PARTS NAME
NO MARK ELECTROLYTIC CAPACITOR	TANTALUM CAPACITOR	NO MARK CARBON FILM RESISTOR (P=5)	CARBON FILM RESISTOR (P=10)
NO MARK CERAMIC CAPACITOR	CERAMIC TUBULAR CAPACITOR	METAL OXIDE FILM RESISTOR	METAL PLATE RESISTOR
POLYESTER FILM CAPACITOR	POLYESTER FILM CAPACITOR	FIRE PROOF CARBON FILM RESISTOR	CEMENT MOUNTED RESISTOR
POLYETHYLENE FILM CAPACITOR	POLYETHYLENE FILM CAPACITOR	SEMI VARIABLE RESISTOR	CHIP RESISTOR
POLYPROPYLENE FILM CAPACITOR	POLYPROPYLENE FILM CAPACITOR		
SEMICONDUCTIVE CERAMIC CAPACITOR	SEMICONDUCTIVE CERAMIC CAPACITOR		
POLYPHENYLENE SULFIDE FILM CAPACITOR	POLYPHENYLENE SULFIDE FILM CAPACITOR		

- \* All voltages are measured with a 10M Ω DC electric volt meter.
- \* Components having special characteristics are marked Δ and must be replaced with parts having specifications equal to those originally installed.
- \* Schematic diagram is subject to change without notice.
- 電圧は、内部抵抗10MΩの電圧計で測定したものです。
- Δ印のある部品は、安全性確保部品を示しています。部品の交換が必要な場合、パーツリストに記載されている部品を使用してください。
- 本回路図は標準回路図です。改良のため予告なく変更することがございます。

RX-V1200/RX-V1200RDS/HTR-5490/DSP-AX1200/RX-V2200/DSP-AX2200  
**SCHEMATIC DIAGRAM (RX-V2200/DSP-AX2200 FUNCTION)**

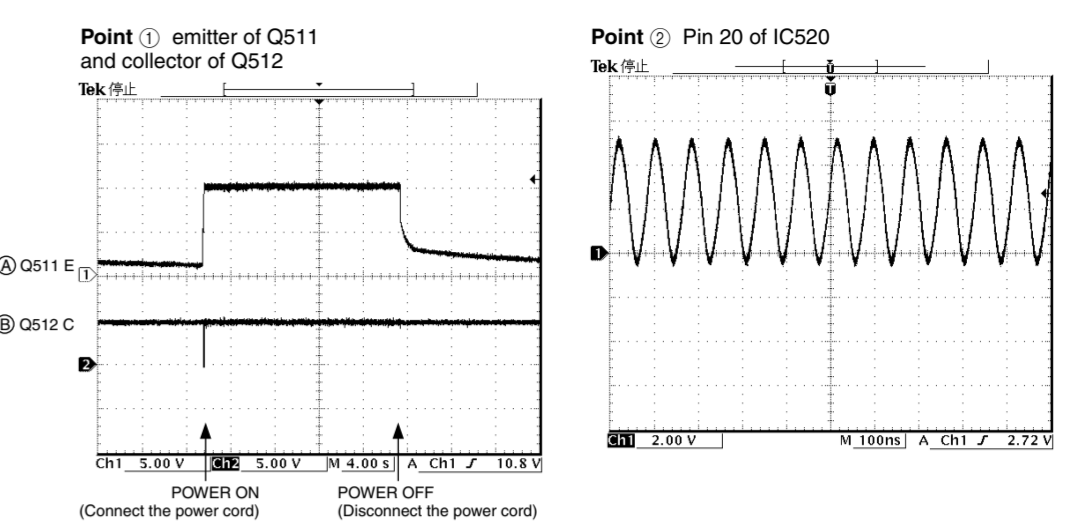
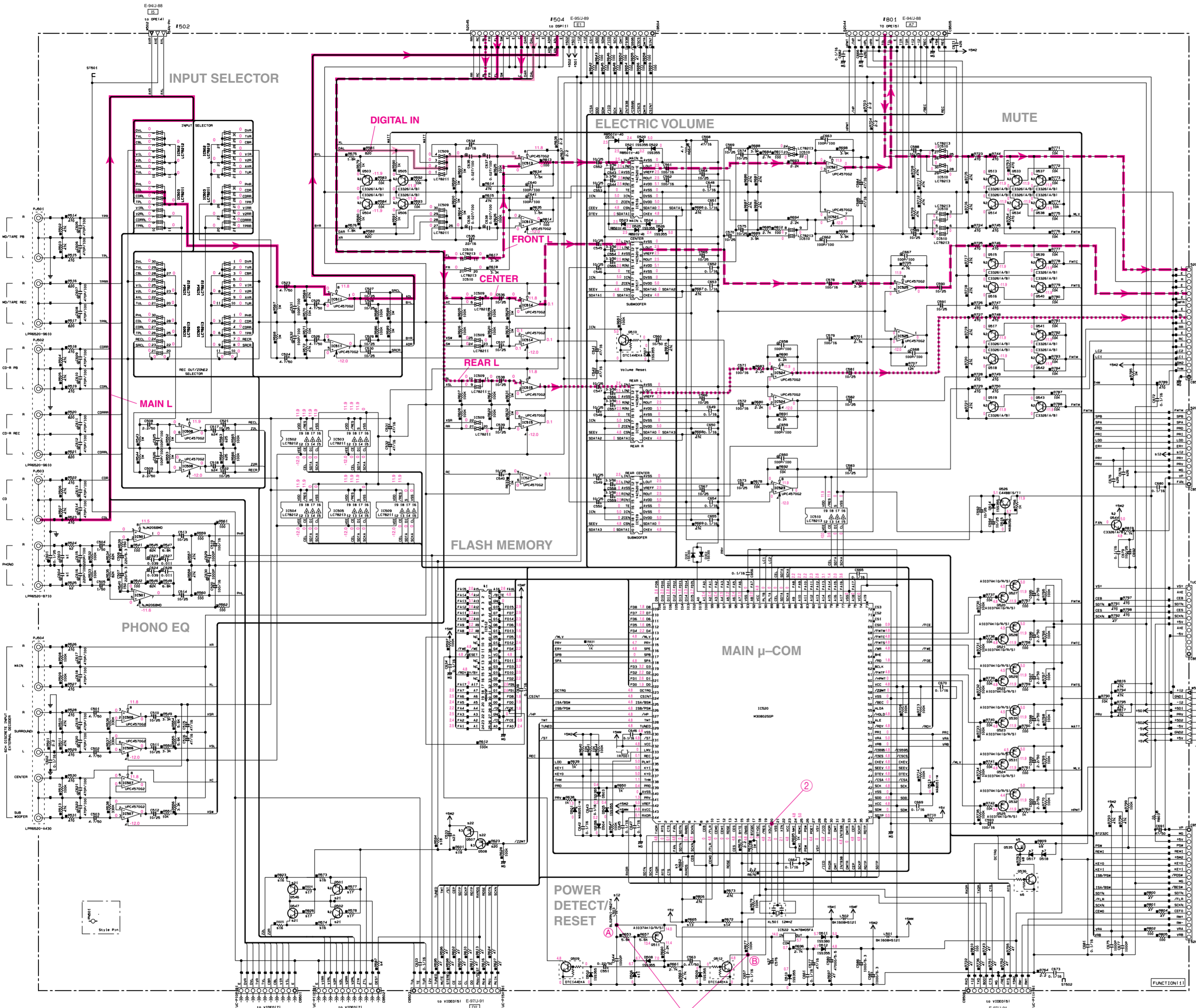

IC500: NJM2068MD  
 IC506-508, 511, 513-515: μPC4570G2  
 IC521, IC523-IC525: μPC4570G2  
 Dual OP-Amp

OUT1 1, 2, 3, 4, 5, 6, 7, 8  
 +Vcc, -Vcc, +In, -In

IC No.	Part No.	U-C	QTY	Remarks
1	IC500-504	47	47	200V/100μF
2	IC504-520	47	47	2.2K
3	IC504	100K	100K	
4	IC507	47	47	
5	IC506	DTC144E4	DTC144E4	DTC144E4
6	IC508	100	100	
7	IC511-518	100	100	
8	IC513	33K	33K	
9	IC509	47	47	
10	IC506	100K	100K	
11	IC506	100K	100K	
12	IC506	100K	100K	
13	IC506	100K	100K	
14	IC506	100K	100K	
15	IC506	100K	100K	
16	IC506	100K	100K	
17	IC506	100K	100K	
18	IC506	100K	100K	
19	IC506	100K	100K	
20	IC506	100K	100K	
21	IC506	100K	100K	
22	IC506	100K	100K	
23	IC506	100K	100K	
24	IC506	100K	100K	
25	IC506	100K	100K	
26	IC506	100K	100K	
27	IC506	100K	100K	
28	IC506	100K	100K	
29	IC506	100K	100K	
30	IC506	100K	100K	

X: NOT USED  
 O: USED / APPLICABLE

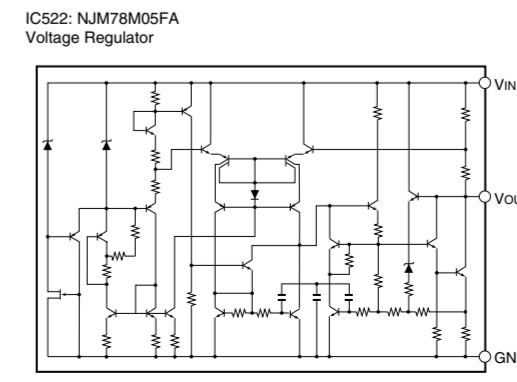
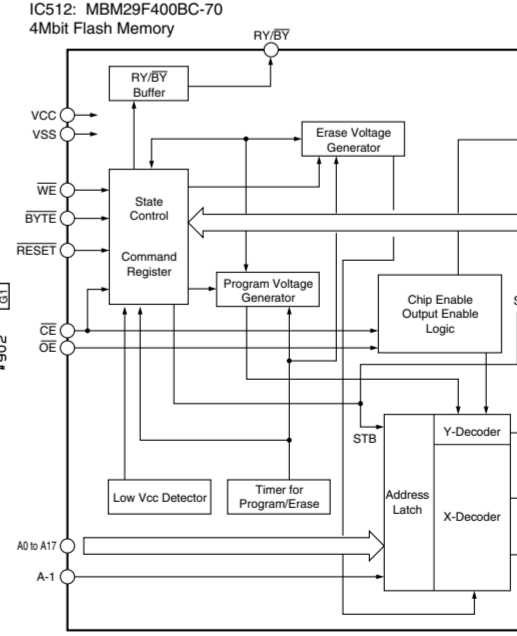
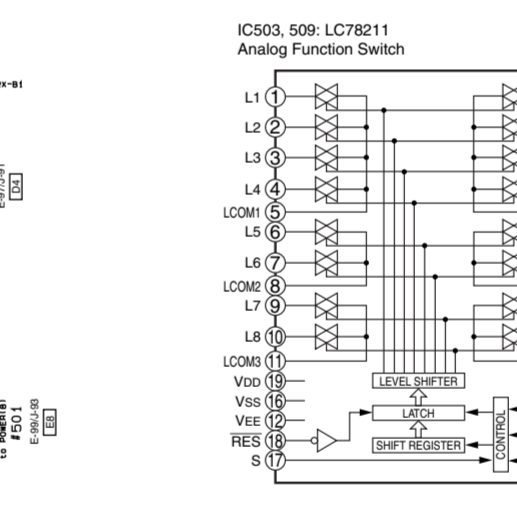

NOTICE (model)

Interchangeable Parts at Manufacture Stage

Part No.	Part Name	Remarks
1	10510	
2	20100, 21010, 221, 234	RESISTOR
3	20100, 21010, 221, 234	RESISTOR
4	20100, 21010, 221, 234	RESISTOR
5	20100, 21010, 221, 234	RESISTOR
6	20100, 21010, 221, 234	RESISTOR
7	20100, 21010, 221, 234	RESISTOR
8	20100, 21010, 221, 234	RESISTOR
9	20100, 21010, 221, 234	RESISTOR
10	20100, 21010, 221, 234	RESISTOR
11	20100, 21010, 221, 234	RESISTOR
12	20100, 21010, 221, 234	RESISTOR
13	20100, 21010, 221, 234	RESISTOR
14	20100, 21010, 221, 234	RESISTOR
15	20100, 21010, 221, 234	RESISTOR
16	20100, 21010, 221, 234	RESISTOR
17	20100, 21010, 221, 234	RESISTOR
18	20100, 21010, 221, 234	RESISTOR
19	20100, 21010, 221, 234	RESISTOR
20	20100, 21010, 221, 234	RESISTOR
21	20100, 21010, 221, 234	RESISTOR
22	20100, 21010, 221, 234	RESISTOR
23	20100, 21010, 221, 234	RESISTOR
24	20100, 21010, 221, 234	RESISTOR
25	20100, 21010, 221, 234	RESISTOR
26	20100, 21010, 221, 234	RESISTOR
27	20100, 21010, 221, 234	RESISTOR
28	20100, 21010, 221, 234	RESISTOR
29	20100, 21010, 221, 234	RESISTOR
30	20100, 21010, 221, 234	RESISTOR

REMARKS: \* All voltages are measured with a 10M Ω DC electric volt meter.  
 \* Components having special characteristics are marked Δ and must be replaced with parts having specifications equal to those originally installed.  
 \* Schematic diagram is subject to change without notice.

● 電圧は、内部抵抗10MΩの電圧計で測定したものです。  
 ● Δ印のある部品は、安全性確保部品を示しています。部品の交換が必要な場合、パーツリストに記載されている部品を使用してください。  
 ● 本回路図は標準回路図です。改良のため予告なく変更することがございます。



■ SCHEMATIC DIAGRAM (OPERATION)

RX-V1200/RX-V1200RDS/HTR-5490/DSP-AX1200/RX-V2200/DSP-AX2200

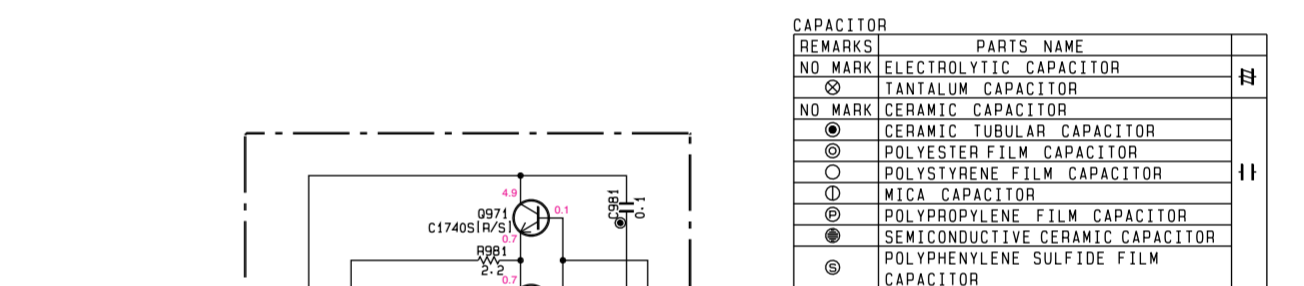
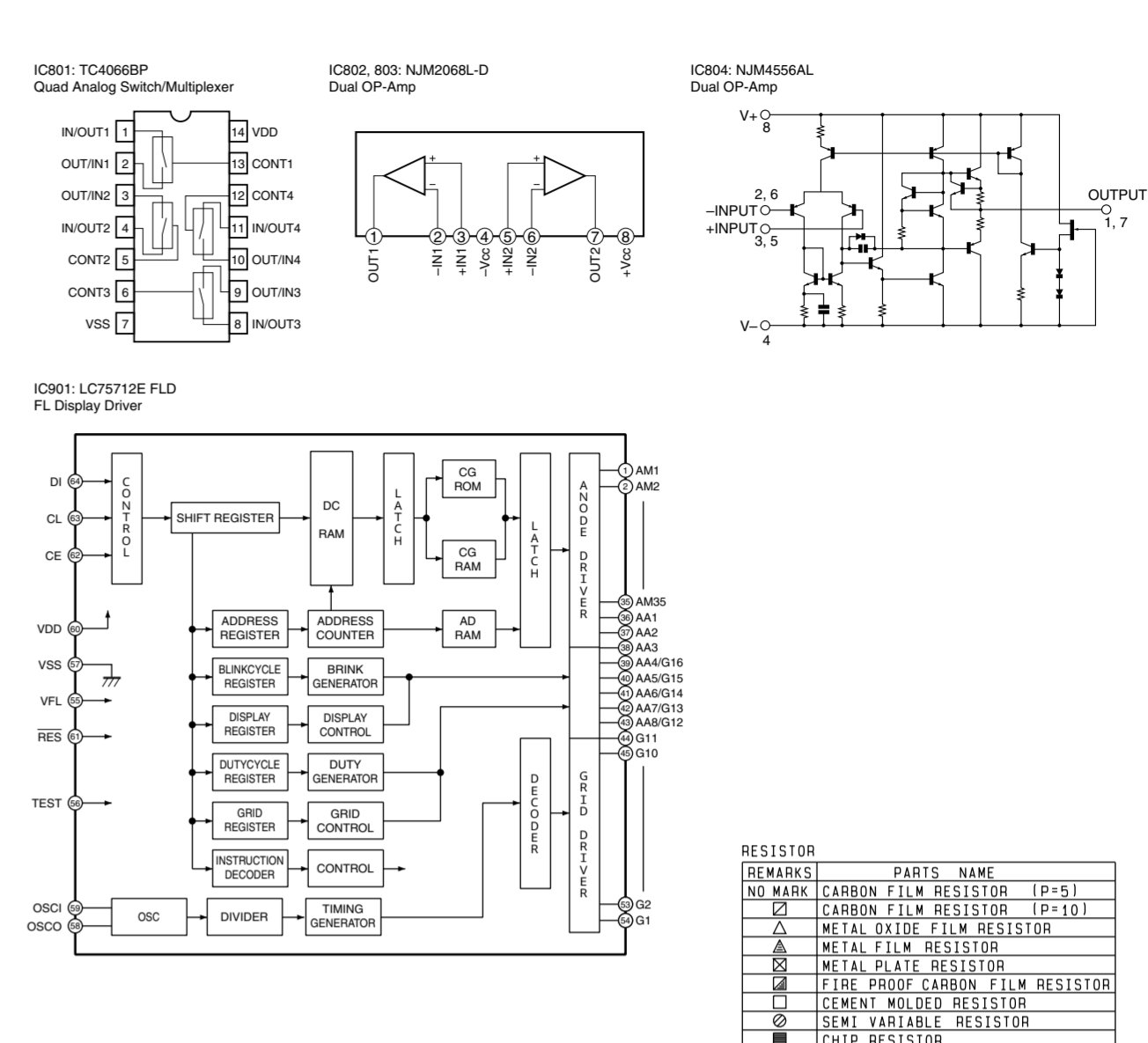
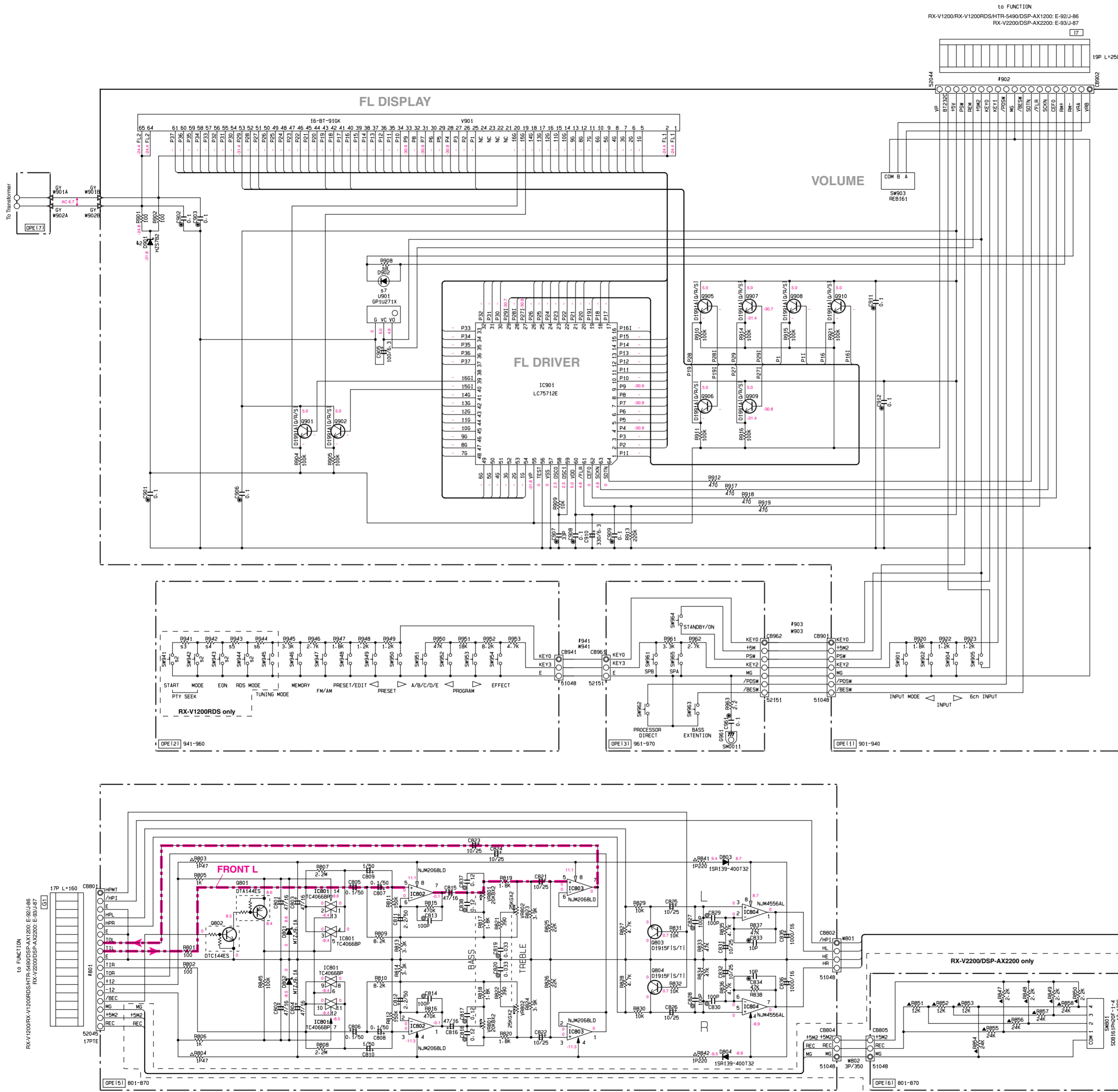

RESISTOR

REMARKS	PARTS NAME
NO MARK	CARBON FILM RESISTOR (P=5)
△	CARBON FILM RESISTOR (P=10)
□	METAL OXIDE FILM RESISTOR
⊗	METAL FILM RESISTOR
⊙	FIRE PROOF CARBON FILM RESISTOR
⊠	CEMENT WOLDED RESISTOR
⊞	SEMI VARIABLE RESISTOR
■	CHIP RESISTOR

CAPACITOR

REMARKS	PARTS NAME
NO MARK	ELECTROLYTIC CAPACITOR
⊗	TANTALUM CAPACITOR
NO MARK	CERAMIC CAPACITOR
⊙	CERAMIC TUBULAR CAPACITOR
⊞	POLYESTER FILM CAPACITOR
⊠	POLYSTYRENE FILM CAPACITOR
⊡	MICA CAPACITOR
⊙	POLYPROPYLENE FILM CAPACITOR
⊞	SEMICONDUCTIVE CERAMIC CAPACITOR
⊙	POLYPHENYLENE SULFIDE FILM CAPACITOR

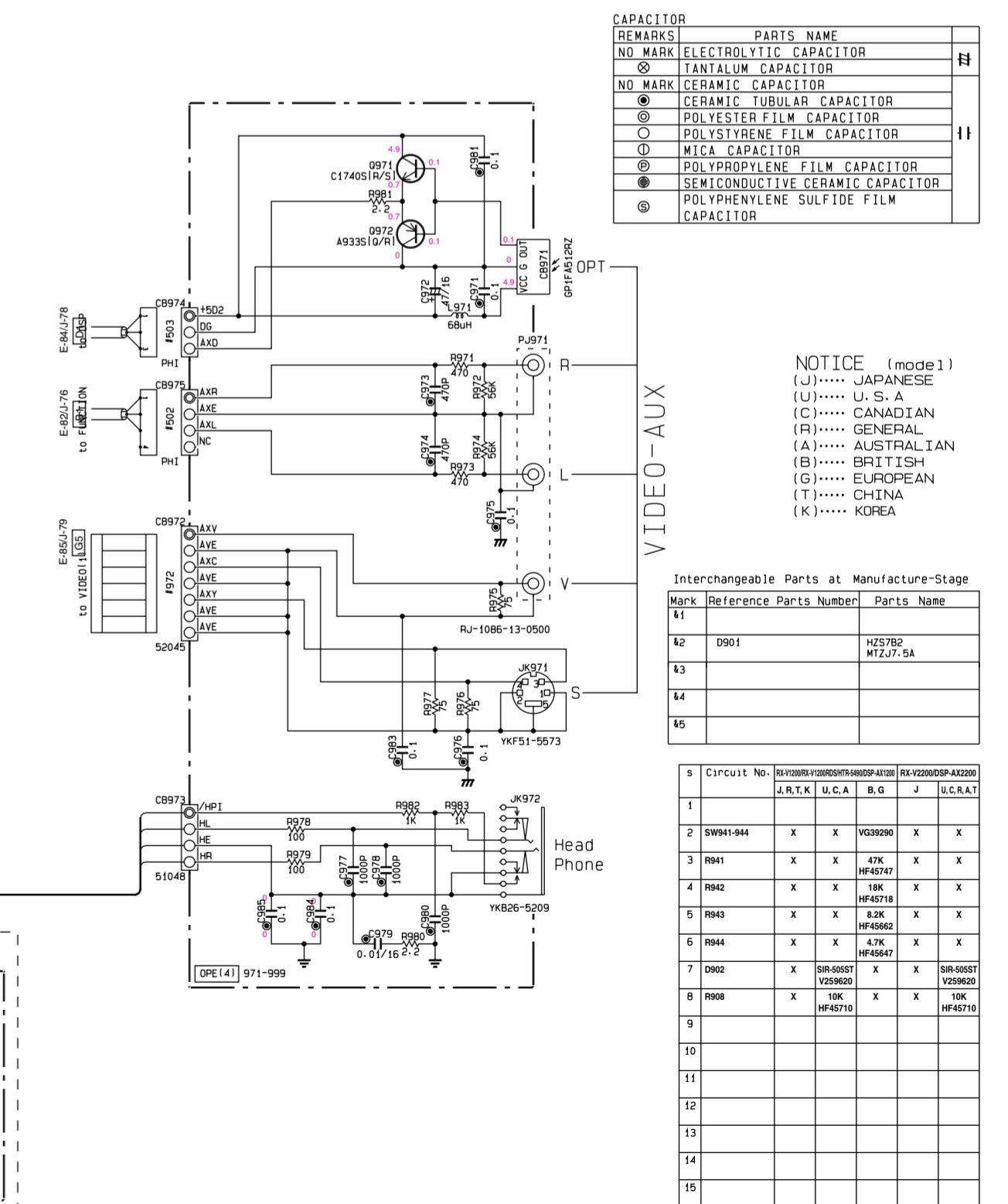

NOTICE (model)  
 (J)..... JAPANESE  
 (U)..... U.S. A  
 (C)..... CANADIAN  
 (R)..... GENERAL  
 (A)..... AUSTRALIAN  
 (B)..... BRITISH  
 (G)..... EUROPEAN  
 (T)..... CHINA  
 (K)..... KOREA

Interchangeable Parts at Manufacture-Stage

Mark	Reference Parts Number	Parts Name
k1		
k2	D901	HZ57B2 MTJZJ-5A
k3		
k4		
k5		

5 Circuit No. 15 V330R-V1200RDS/HTR-5490/DSP-AX1200/RX-V2200/DSP-AX2200

	J.R.T.K	U.C.A.	B.G.	J	U.C.R.T
1					
2	SW941-944	X	X	VG39290	X X
3	R941	X	X	47K HF45718	X X
4	R942	X	X	18K HF45718	X X
5	R943	X	X	8.2K HF45718	X X
6	R944	X	X	4.7K HF45718	X X
7	D902	X	X	SR-0057 VZ9060	X X
8	R908	X	X	10K HF45710	X X
9					
10					
11					
12					
13					
14					
15					

X: NOT USED  
 O: USED / APPLICABLE

\* All voltages are measured with a 10M $\Omega$  /V DC electric volt meter.  
 \* Components having special characteristics are marked  $\Delta$  and must be replaced with parts having specifications equal to those originally installed.  
 \* Schematic diagram is subject to change without notice.

● 電圧は、内部抵抗10M $\Omega$ の電圧計で測定したものです。  
 ●  $\Delta$ 印のある部品は、安全性確保部品を示しています。部品の交換が必要な場合、パーツリストに記載されている部品を使用してください。  
 ● 本回路図は標準回路図です。改良のため予告なく変更することがございます。

RX-V1200/RX-V1200RDS/HTR-5490/DSP-AX1200/RX-V2200/DSP-AX2200  
**SCHEMATIC DIAGRAM (DSP)**

Interchangeable Parts at Manufacture Stage

Mark	Reference Parts Number	Parts Name
A1	0508-810-817	25C33061A/B1
A2	IC013	U1000004
A3	IC015	U1000004
A4	IC028	MBM29F400C-70PPT

NOTICE (model)

- (J) JAPANESE
- (U) U.S.A.
- (C) CANADIAN
- (R) GENERAL
- (A) AUSTRALIAN
- (B) BRITISH
- (T) EUROPEAN
- (G) CHINA
- (K) KOREA

- RESISTOR
- REMARKS: CARBON FILM RESISTOR (P=5)
  - METAL OXIDE FILM RESISTOR
  - METAL FILM RESISTOR
  - METAL PLATE RESISTOR
  - THICK FIBRE CARBON FILM RESISTOR
  - CEMENT MOLDED RESISTOR
  - SEMI VARIABLE RESISTOR
  - CHIP RESISTOR
- CAPACITOR
- REMARKS: ELECTROLYTIC CAPACITOR
  - TANTALUM CAPACITOR
  - CERAMIC CAPACITOR
  - CERAMIC TUBULAR CAPACITOR
  - POLYESTER FILM CAPACITOR
  - MICA CAPACITOR
  - POLYPROPYLENE FILM CAPACITOR
  - SEMICONDUCTIVE CERAMIC CAPACITOR
  - POLYPHENYLENE SULFIDE FILM CAPACITOR

to OPERATION

- All voltages are measured with a 10M  $\Omega$  DC electric volt meter.
- Components having special characteristics are marked  $\Delta$  and must be replaced with parts having specifications equal to those originally installed.
- Schematic diagram is subject to change without notice.
- 電圧は、内部抵抗10M $\Omega$ の電圧計で測定したものです。
- $\Delta$ 印のある部品は、安全性確保部品を示しています。部品の交換が必要な場合、パーツリストに記載されている部品を使用してください。
- 本回路図は標準回路図です。改良のため予告なく変更することがございます。

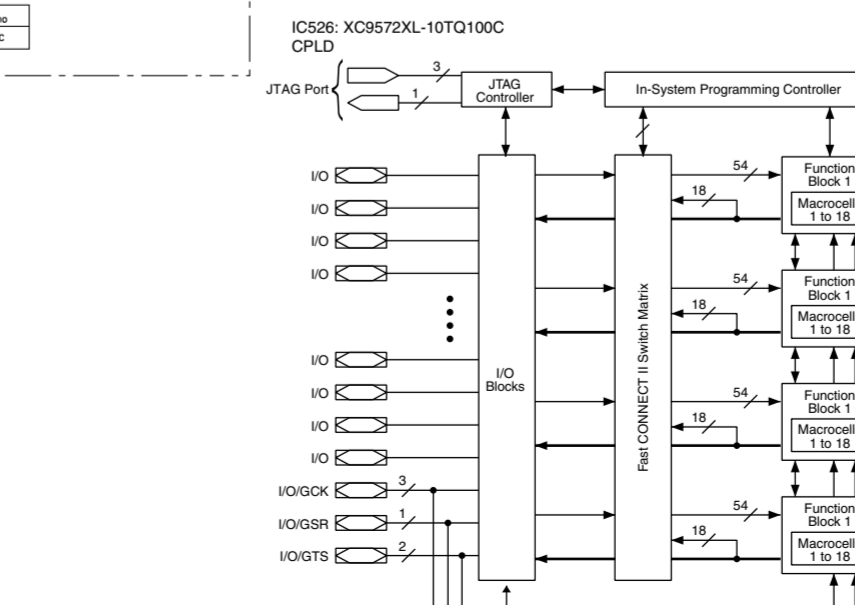
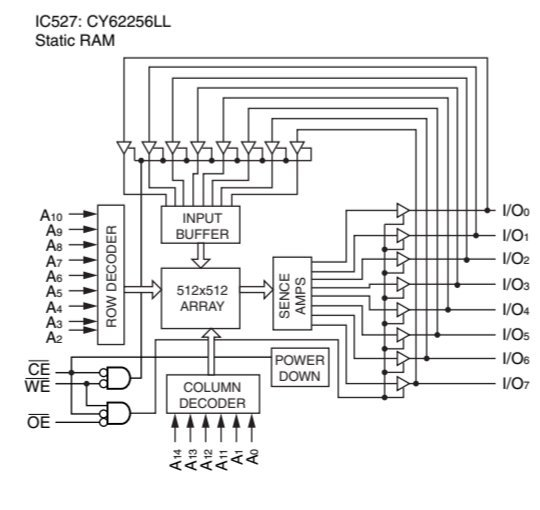
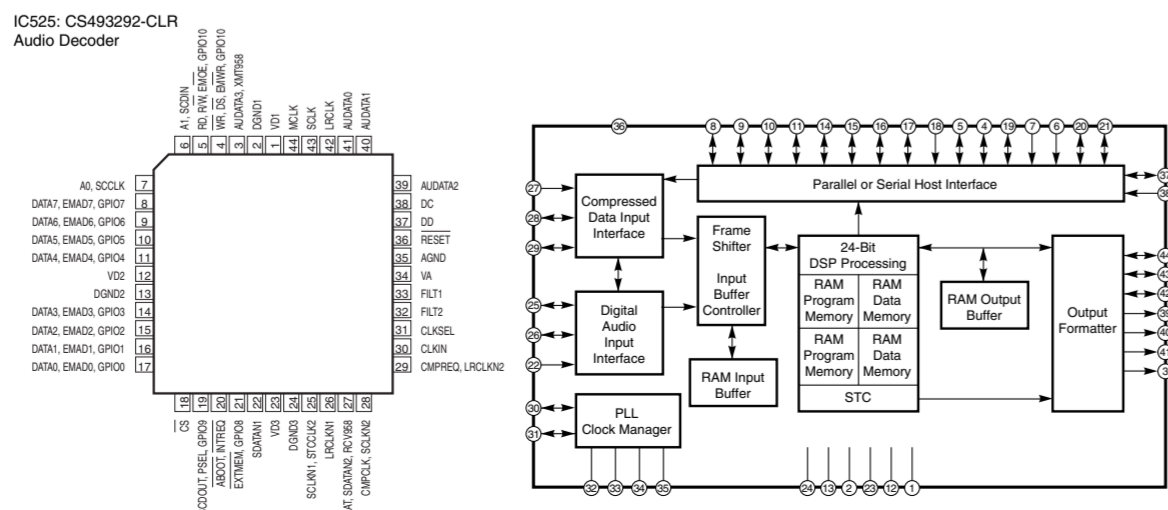
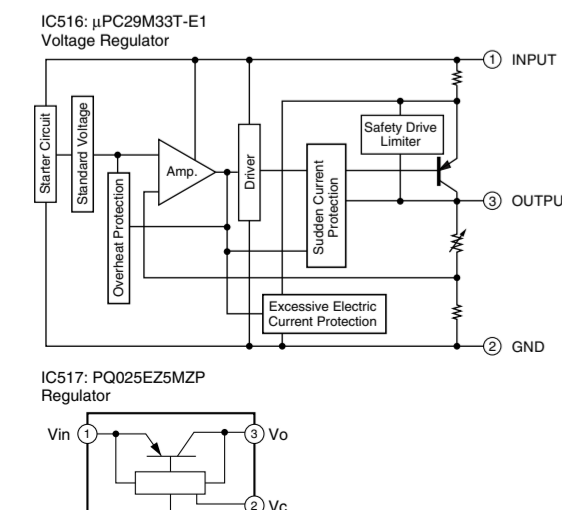
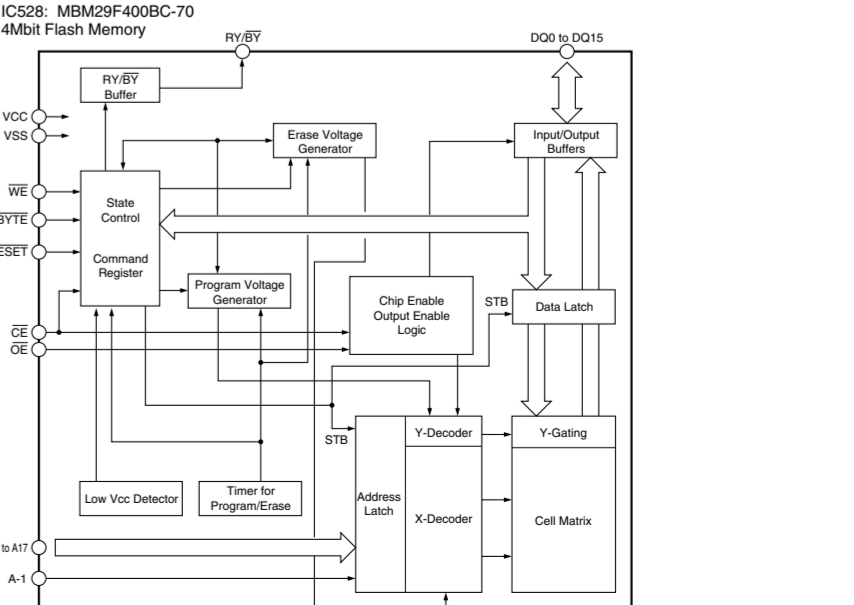
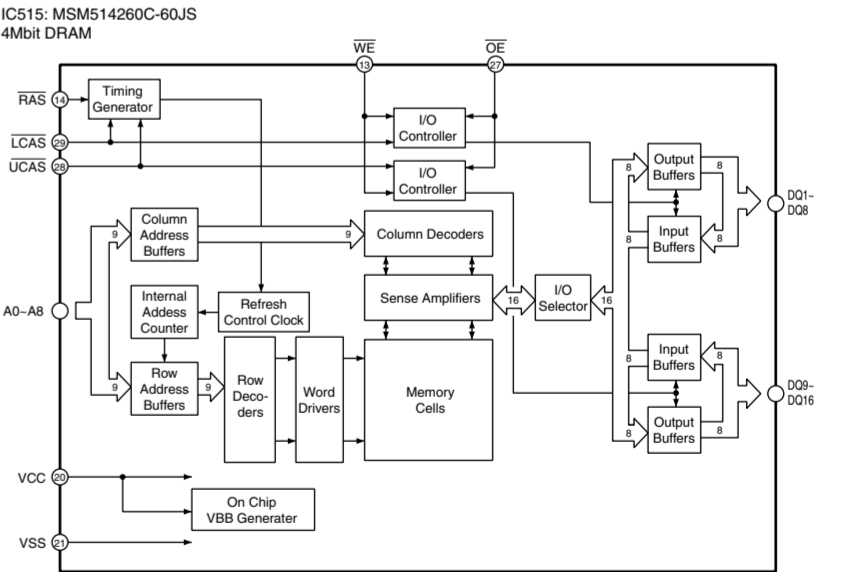
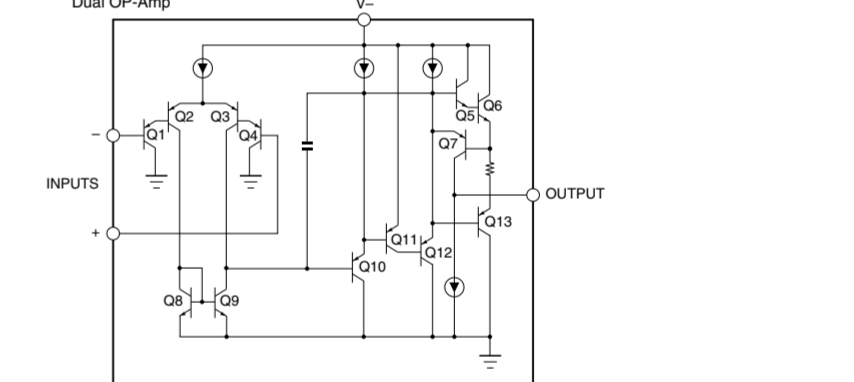
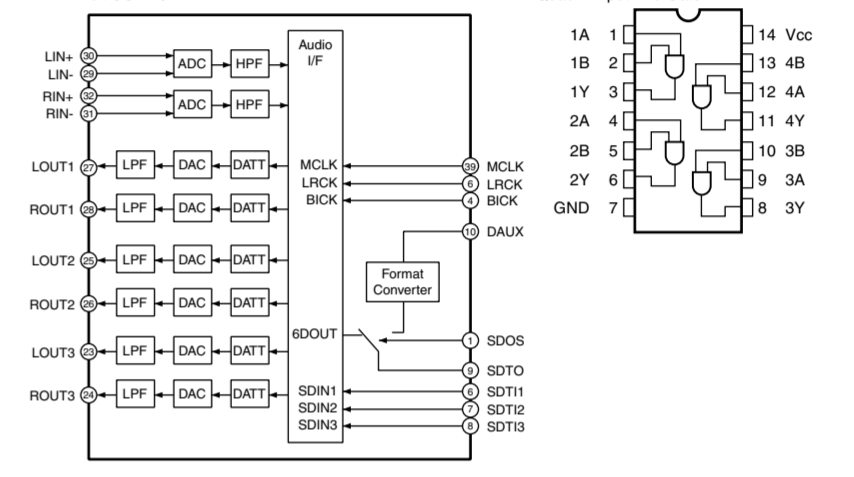
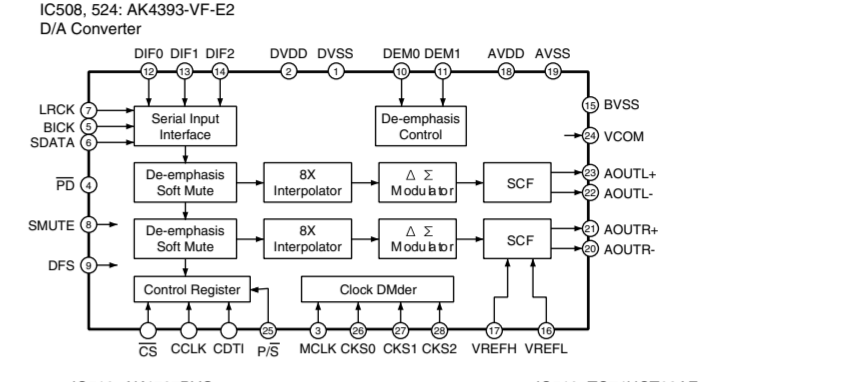
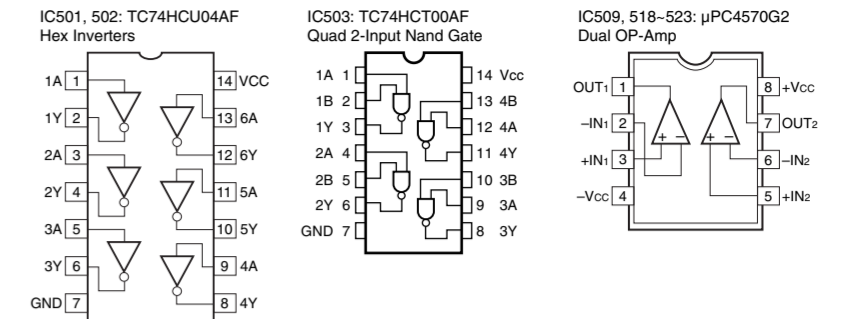
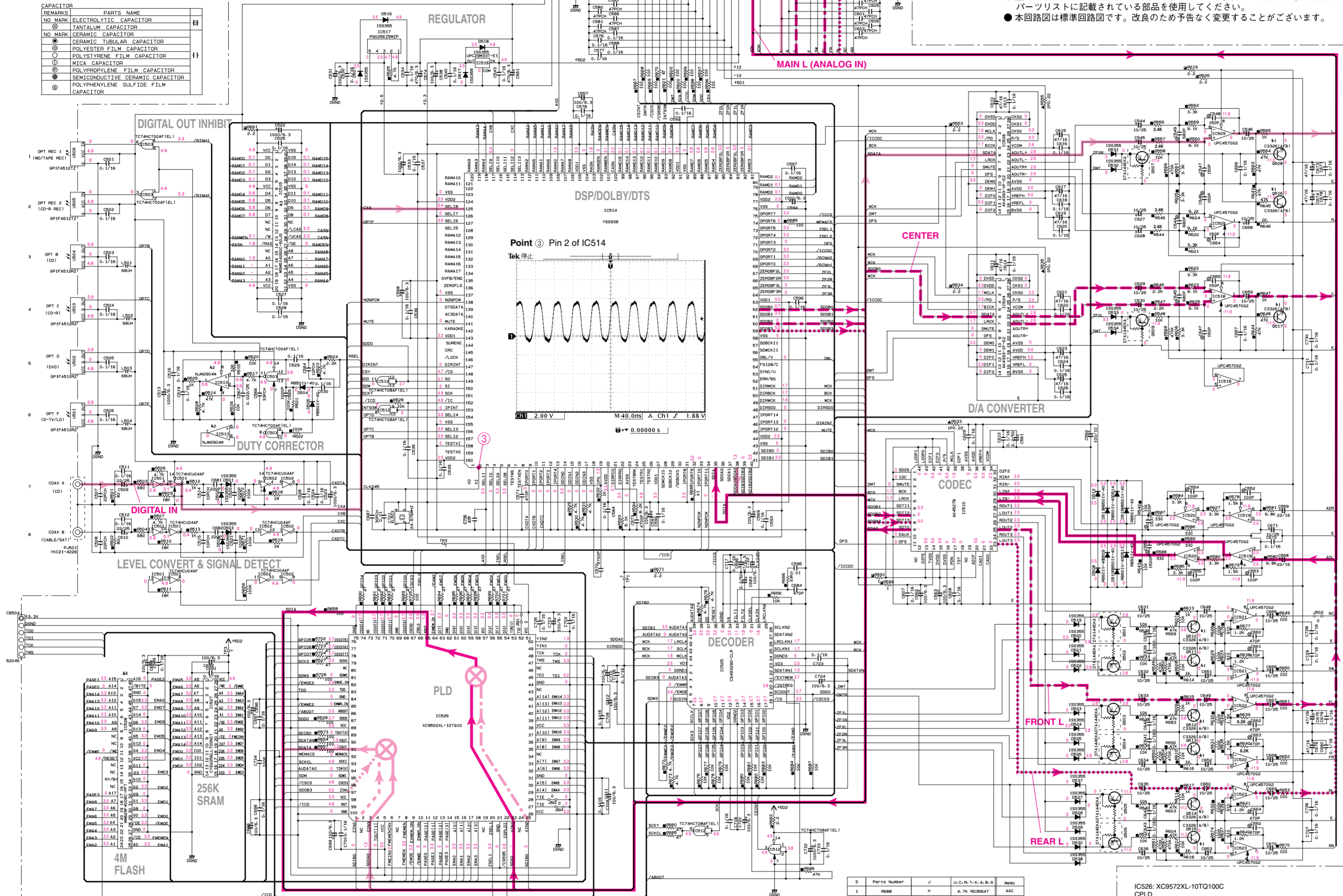

**SCHEMATIC DIAGRAM (RX-V1200/RX-V1200RDS/HTR-5490/DSP-AX1200 VIDEO)**

RX-V1200/RX-V1200RDS/HTR-5490/DSP-AX1200/RX-V2200/DSP-AX2200

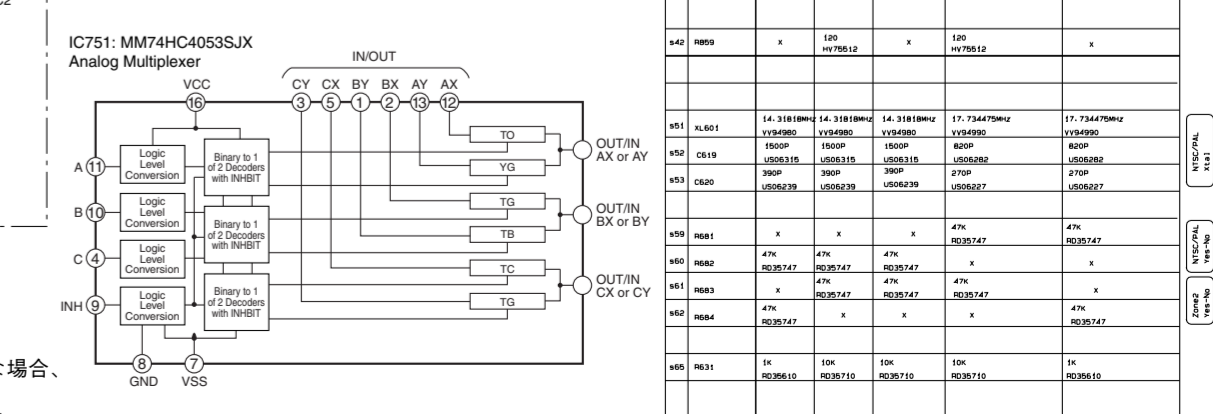
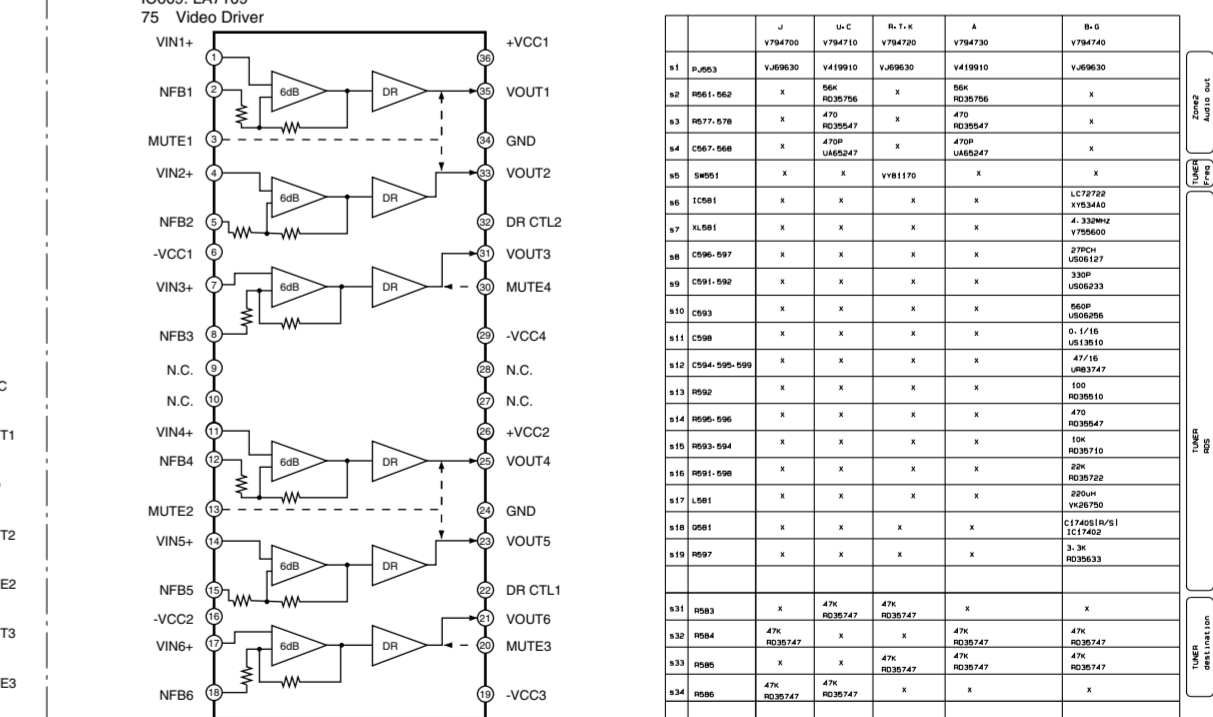
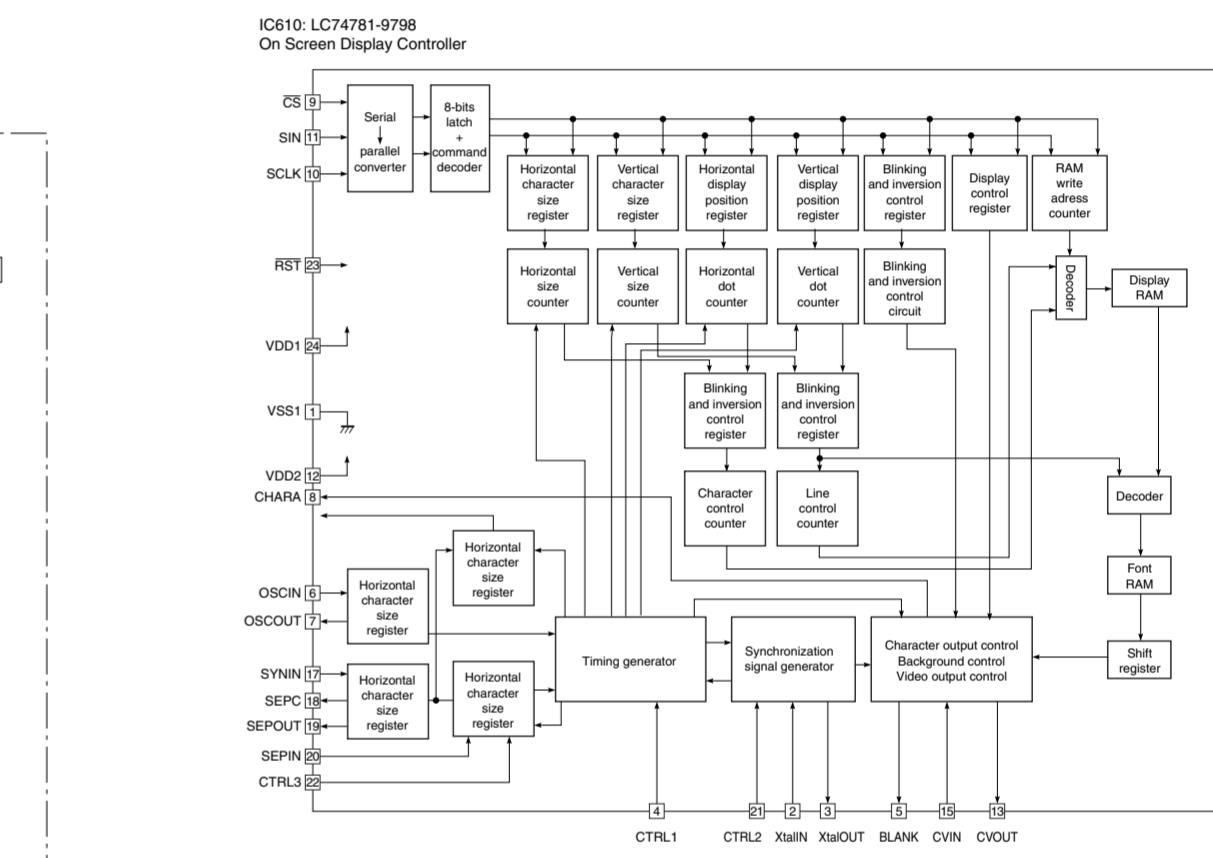
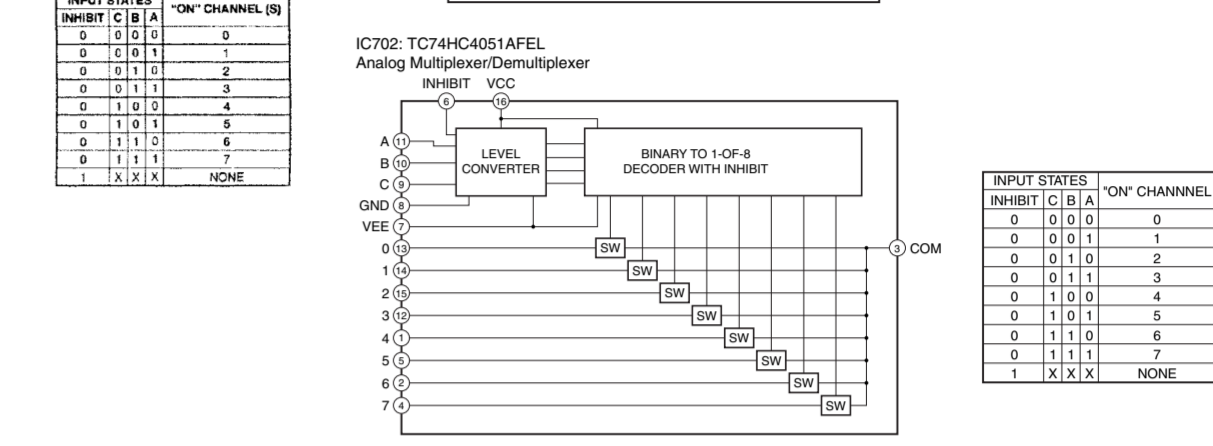
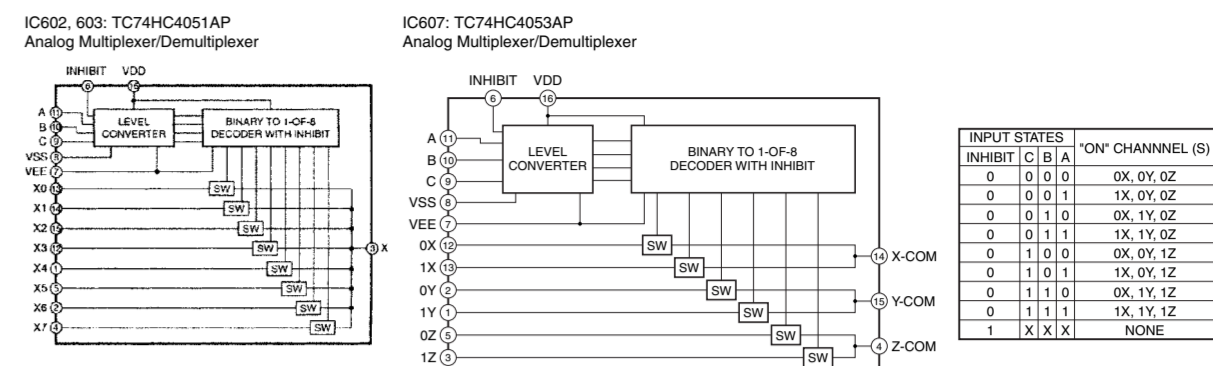
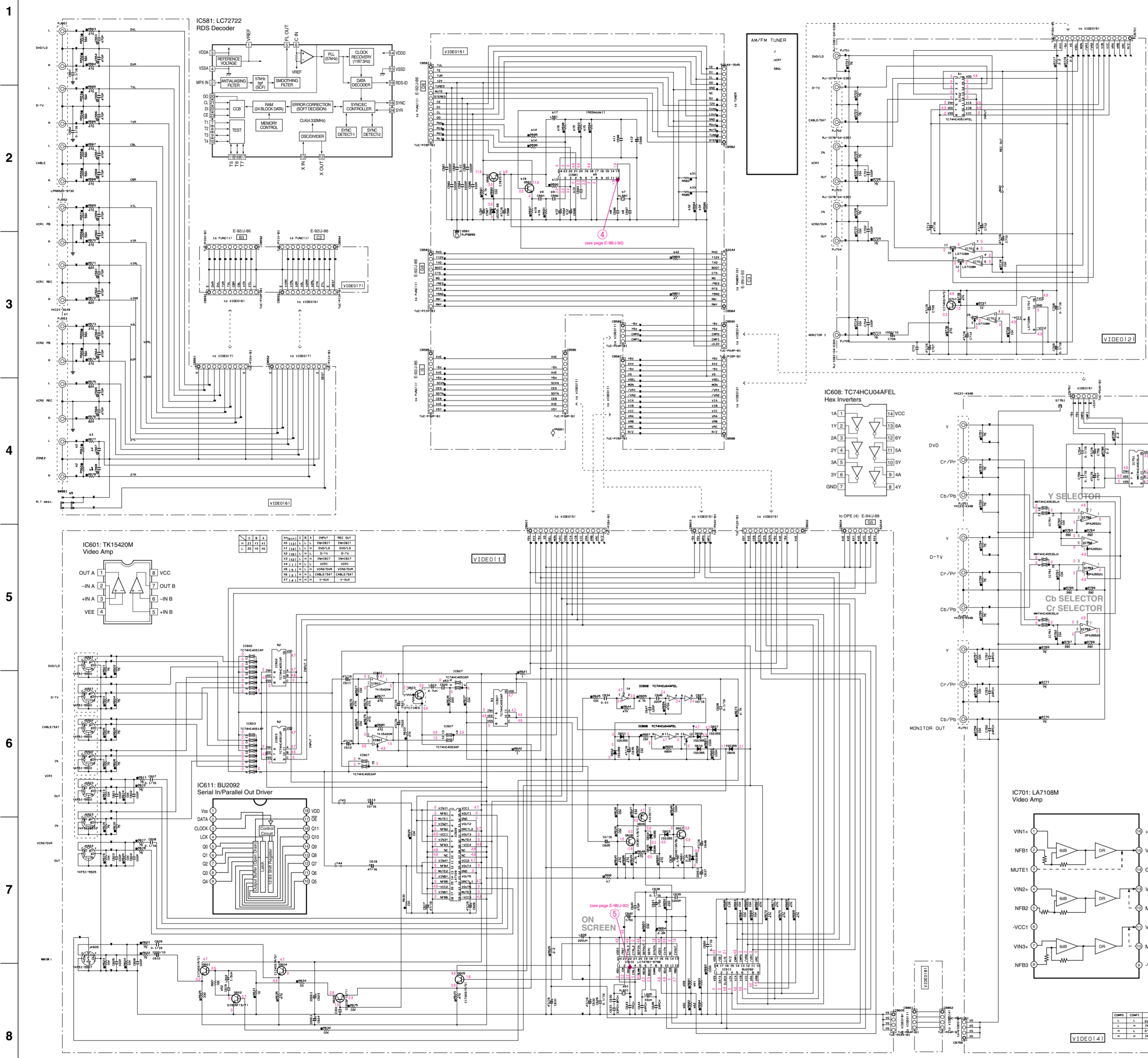

**RESISTOR**

REMARKS	PARTS NAME
NO MARK	CARBON FILM RESISTOR (JWS)
◎	CARBON FILM RESISTOR (SP10)
▲	METAL OXIDE FILM RESISTOR
□	METAL FILM RESISTOR
○	METAL GLAZE RESISTOR
△	FINE PORE CARBON FILM RESISTOR
◇	CEMENT COATED RESISTOR
◇	SEMICONDUCTIVE FILM RESISTOR
◇	CHIP RESISTOR

**CAPACITOR**

REMARKS	PARTS NAME
NO MARK	ELECTROLYTIC CAPACITOR
◎	POLYMER ELECTROLYTIC CAPACITOR
○	CERAMIC CAPACITOR
◇	POLYESTER FILM CAPACITOR
◇	POLYPROPYLENE FILM CAPACITOR
◇	POLYETHYLENE FILM CAPACITOR
◇	SEMICONDUCTIVE CERAMIC CAPACITOR

**NOTICE (mode 1)**

Interchangeable Parts at Manufacturer's Stage

NO.	TYPE	MANUFACTURER'S PART NO.	PARTS NAME
N1	7000-603	TC74HC4051A	ANALOG MULTIPLEXER/DEMULTIPLEXER
N2	7007	TC74HC4053A	ANALOG MULTIPLEXER/DEMULTIPLEXER

★ All voltages are measured with a 10MΩ /V DC electric volt meter.  
 ★ Components having special characteristics are marked ▲, and must be replaced with parts having specifications equal to those originally installed.  
 ★ Schematic diagram is subject to change without notice.

● 電圧は、内部抵抗10MΩの電圧計で測定したものです。  
 ● ▲印のある部品は、安全性確保部品を示しています。部品の交換が必要な場合、パーツリストに記載されている部品を使用してください。  
 ● 本回路図は標準回路図です。改良のため予告なく変更することがございます。

RX-V1200/RX-V1200RDS/HTR-5490/DSP-AX1200/RX-V2200/DSP-AX2200  
**SCHEMATIC DIAGRAM (RX-V2200/DSP-AX2200 VIDEO)**

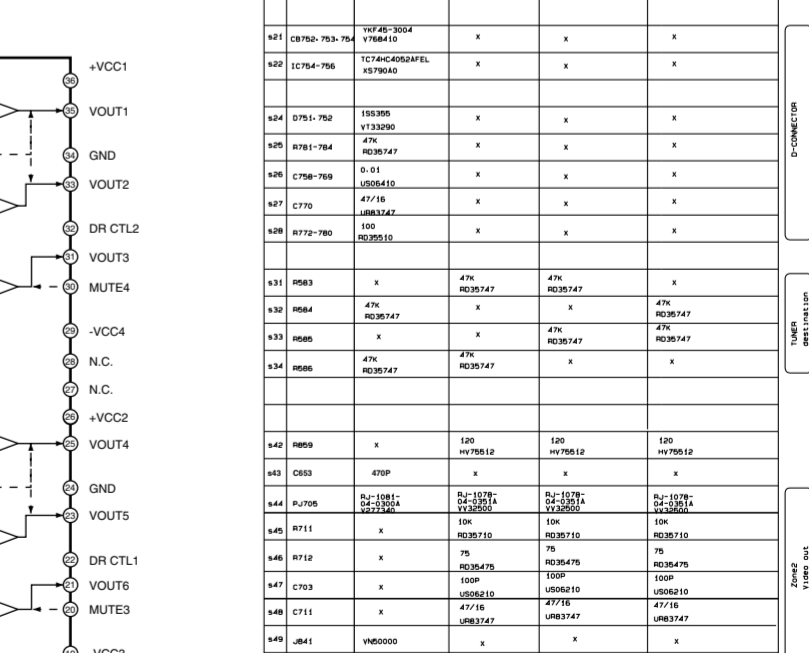
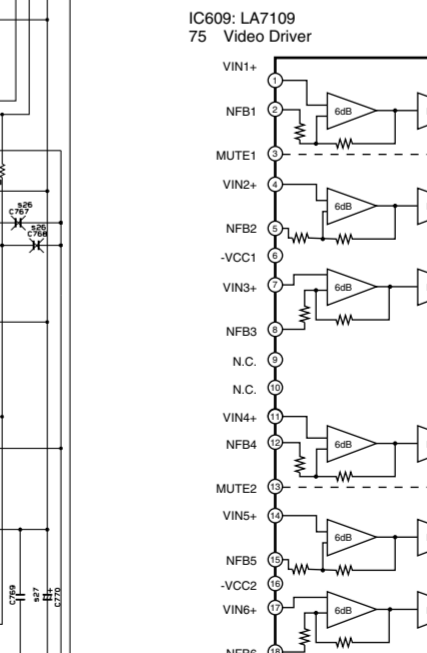
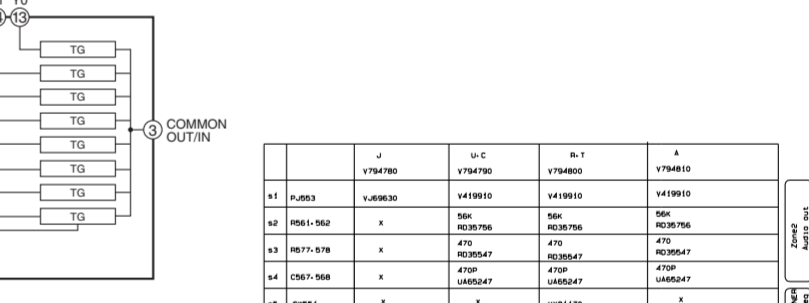
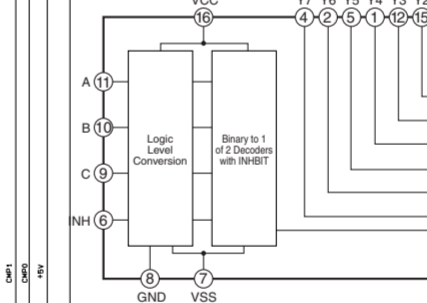
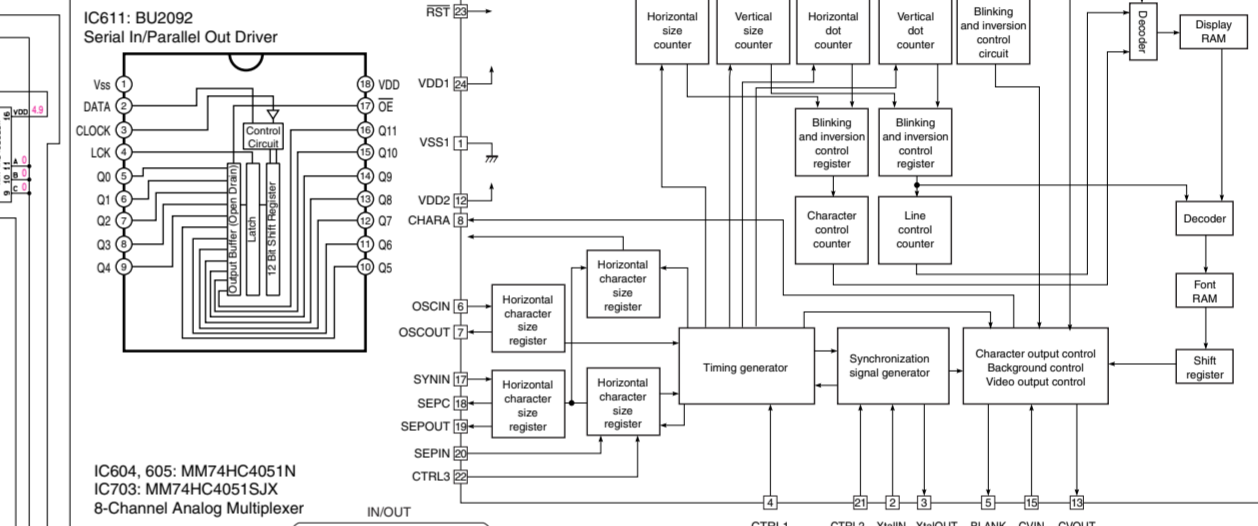
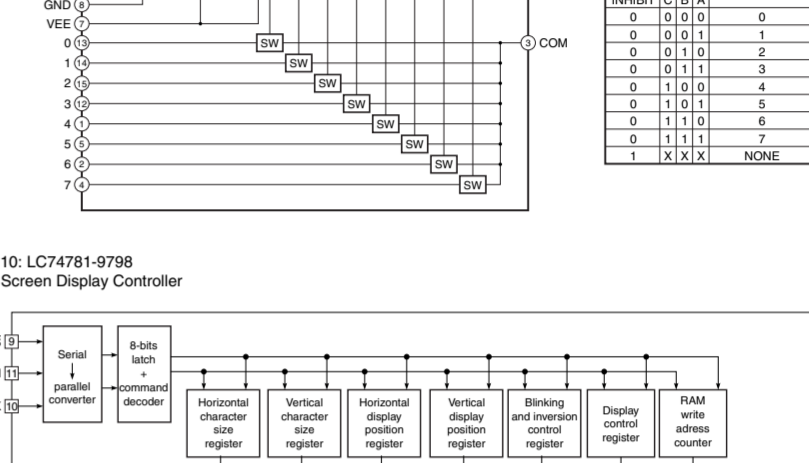
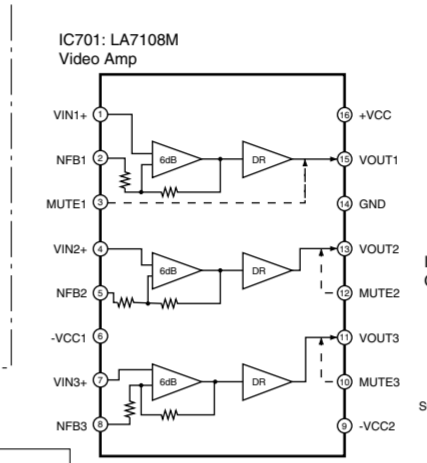
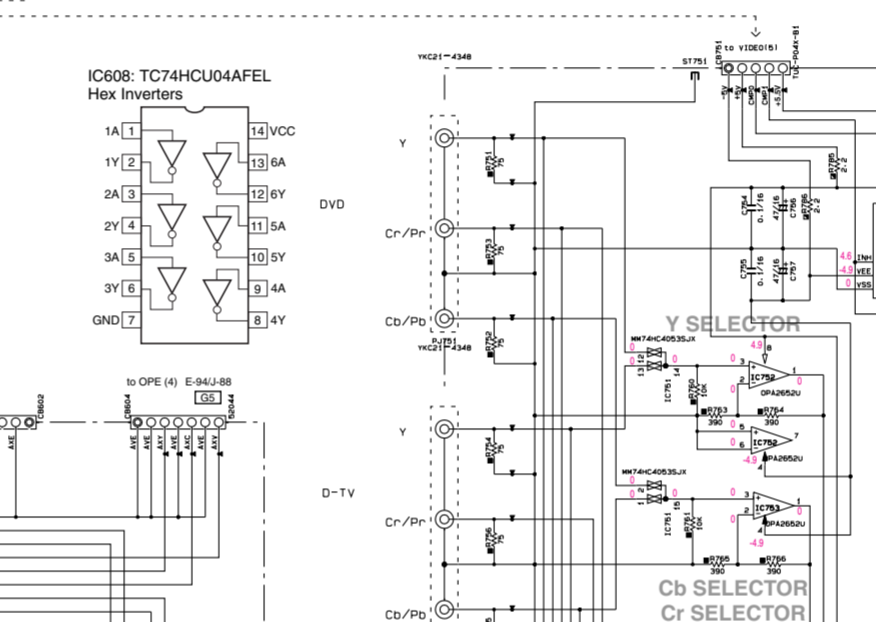
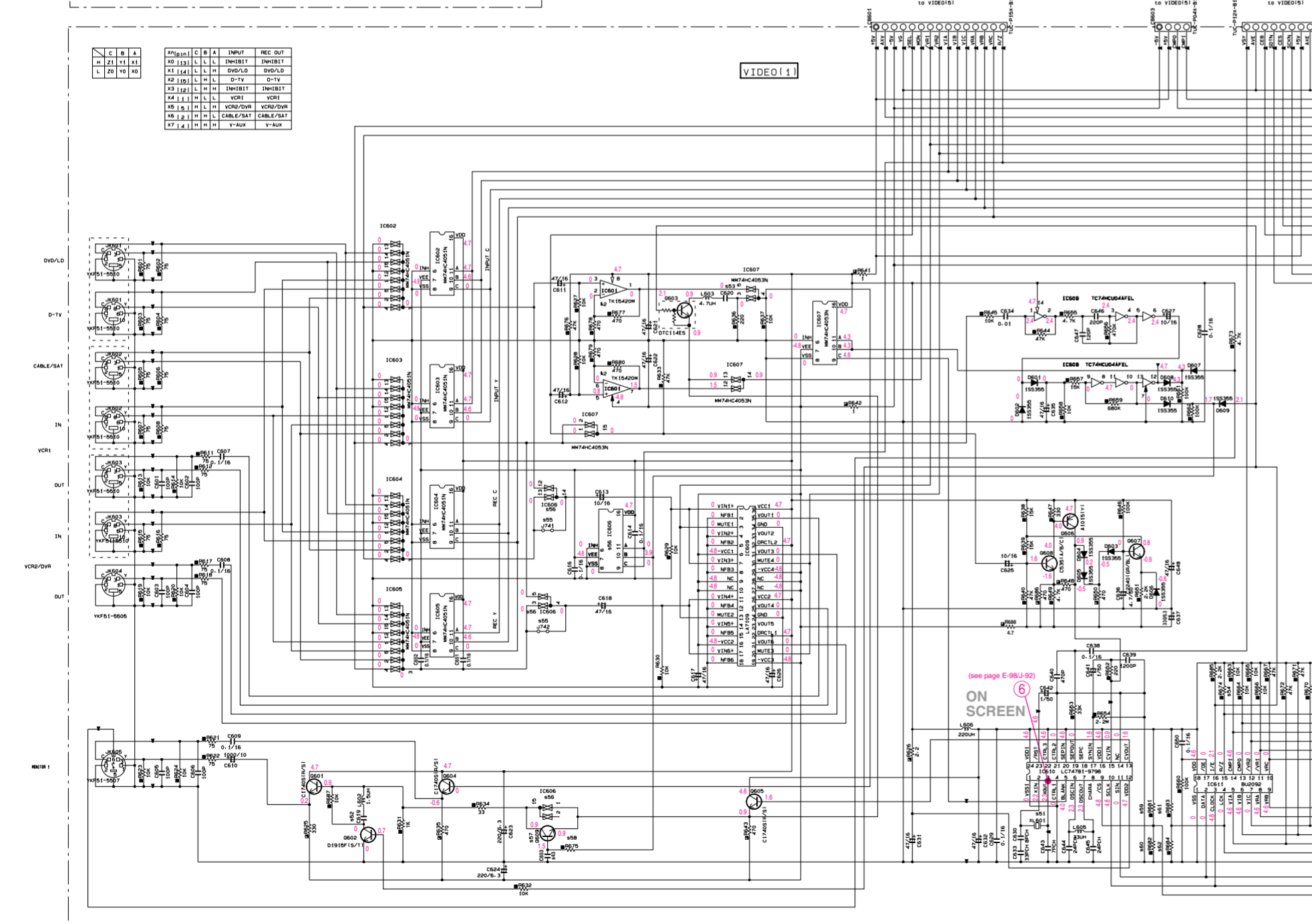
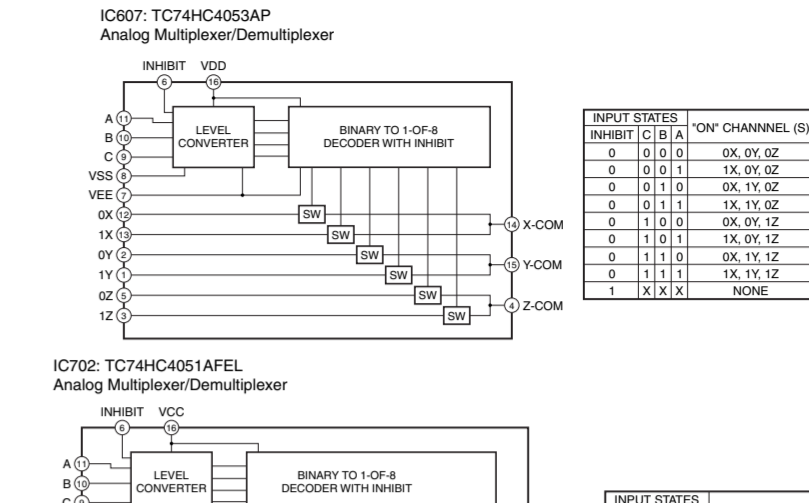
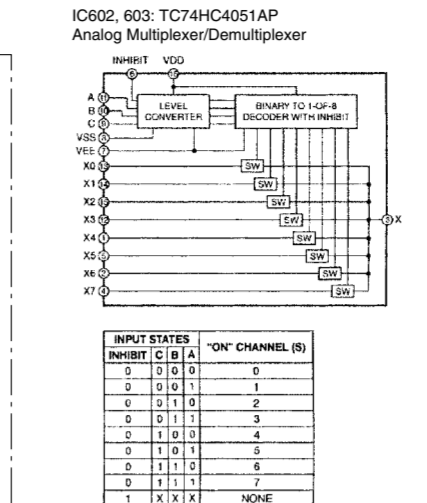
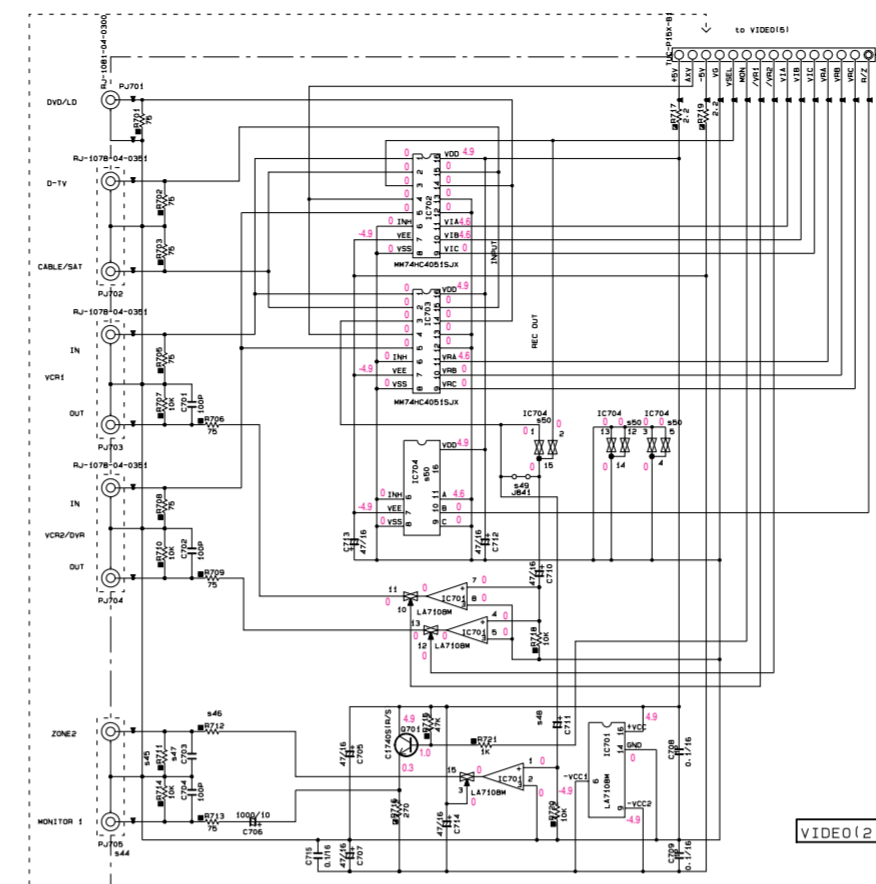
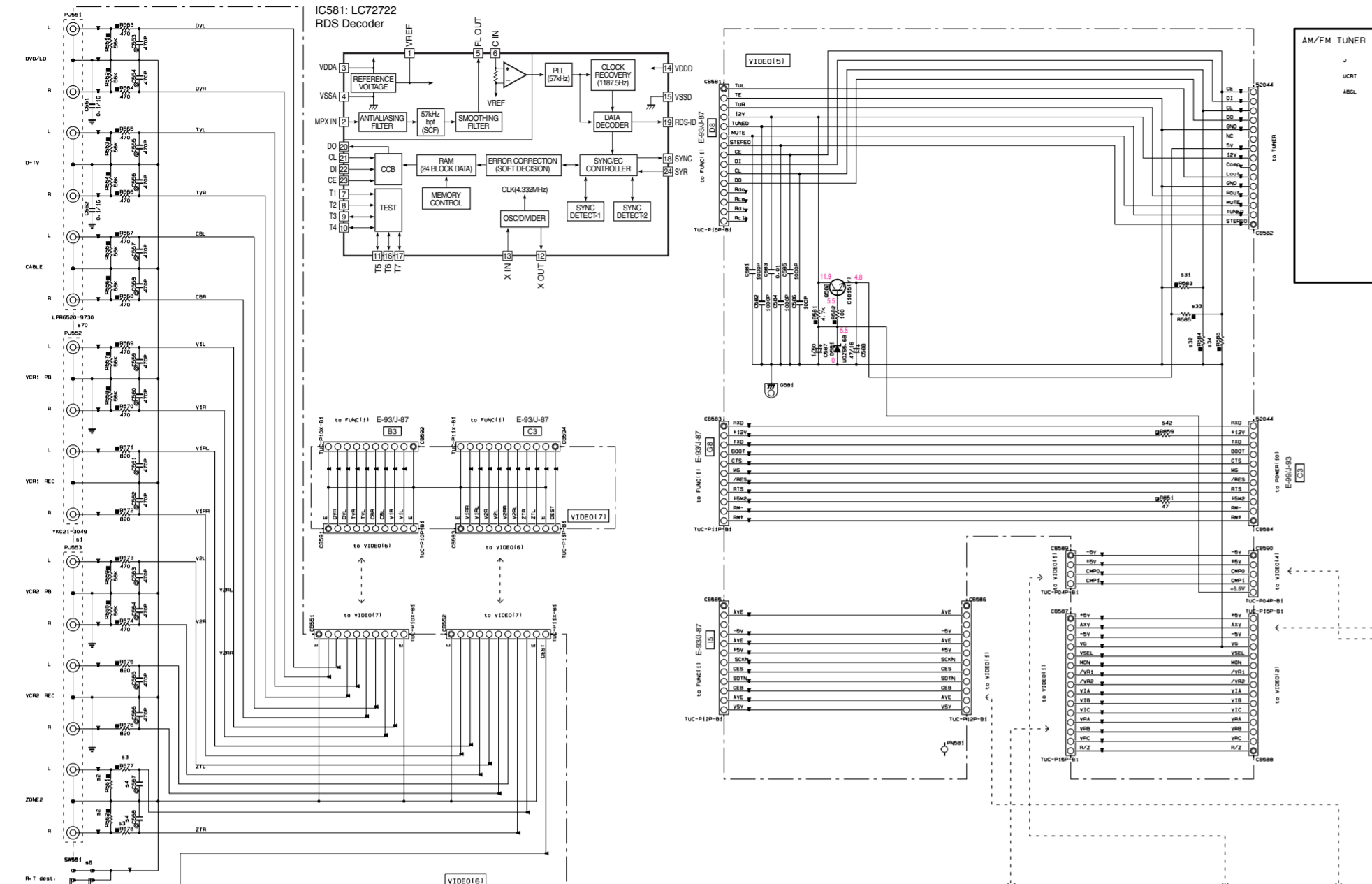

RESISTOR	PARTS NAME	CAPACITOR	PARTS NAME
R	CARBON FILM RESISTOR (1P-5)	CC	NON-POLARIZED CERAMIC CAPACITOR
RT	TANTALUM CAPACITOR	EC	ELECTROLYTIC CAPACITOR
RC	CARBON FILM RESISTOR (1P-10)	CC	TANTALUM CAPACITOR
RA	METAL FILM RESISTOR	CC	NON-POLARIZED CERAMIC CAPACITOR
RF	METAL FILM RESISTOR (1P-1)	CC	NON-POLARIZED CERAMIC CAPACITOR
RG	METAL FILM RESISTOR (1P-2)	CC	NON-POLARIZED CERAMIC CAPACITOR
RH	METAL FILM RESISTOR (1P-3)	CC	NON-POLARIZED CERAMIC CAPACITOR
RI	METAL FILM RESISTOR (1P-4)	CC	NON-POLARIZED CERAMIC CAPACITOR
RJ	METAL FILM RESISTOR (1P-5)	CC	NON-POLARIZED CERAMIC CAPACITOR
RK	METAL FILM RESISTOR (1P-6)	CC	NON-POLARIZED CERAMIC CAPACITOR
RL	METAL FILM RESISTOR (1P-7)	CC	NON-POLARIZED CERAMIC CAPACITOR
RM	METAL FILM RESISTOR (1P-8)	CC	NON-POLARIZED CERAMIC CAPACITOR
RN	METAL FILM RESISTOR (1P-9)	CC	NON-POLARIZED CERAMIC CAPACITOR
RO	METAL FILM RESISTOR (1P-10)	CC	NON-POLARIZED CERAMIC CAPACITOR
RP	METAL FILM RESISTOR (1P-11)	CC	NON-POLARIZED CERAMIC CAPACITOR
RQ	METAL FILM RESISTOR (1P-12)	CC	NON-POLARIZED CERAMIC CAPACITOR
RR	METAL FILM RESISTOR (1P-13)	CC	NON-POLARIZED CERAMIC CAPACITOR
RS	METAL FILM RESISTOR (1P-14)	CC	NON-POLARIZED CERAMIC CAPACITOR
RT	METAL FILM RESISTOR (1P-15)	CC	NON-POLARIZED CERAMIC CAPACITOR
RU	METAL FILM RESISTOR (1P-16)	CC	NON-POLARIZED CERAMIC CAPACITOR
RV	METAL FILM RESISTOR (1P-17)	CC	NON-POLARIZED CERAMIC CAPACITOR
RW	METAL FILM RESISTOR (1P-18)	CC	NON-POLARIZED CERAMIC CAPACITOR
RX	METAL FILM RESISTOR (1P-19)	CC	NON-POLARIZED CERAMIC CAPACITOR
RY	METAL FILM RESISTOR (1P-20)	CC	NON-POLARIZED CERAMIC CAPACITOR
RZ	METAL FILM RESISTOR (1P-21)	CC	NON-POLARIZED CERAMIC CAPACITOR
RA	METAL FILM RESISTOR (1P-22)	CC	NON-POLARIZED CERAMIC CAPACITOR
RB	METAL FILM RESISTOR (1P-23)	CC	NON-POLARIZED CERAMIC CAPACITOR
RC	METAL FILM RESISTOR (1P-24)	CC	NON-POLARIZED CERAMIC CAPACITOR
RD	METAL FILM RESISTOR (1P-25)	CC	NON-POLARIZED CERAMIC CAPACITOR
RE	METAL FILM RESISTOR (1P-26)	CC	NON-POLARIZED CERAMIC CAPACITOR
RF	METAL FILM RESISTOR (1P-27)	CC	NON-POLARIZED CERAMIC CAPACITOR
RG	METAL FILM RESISTOR (1P-28)	CC	NON-POLARIZED CERAMIC CAPACITOR
RH	METAL FILM RESISTOR (1P-29)	CC	NON-POLARIZED CERAMIC CAPACITOR
RI	METAL FILM RESISTOR (1P-30)	CC	NON-POLARIZED CERAMIC CAPACITOR
RJ	METAL FILM RESISTOR (1P-31)	CC	NON-POLARIZED CERAMIC CAPACITOR
RK	METAL FILM RESISTOR (1P-32)	CC	NON-POLARIZED CERAMIC CAPACITOR
RL	METAL FILM RESISTOR (1P-33)	CC	NON-POLARIZED CERAMIC CAPACITOR
RM	METAL FILM RESISTOR (1P-34)	CC	NON-POLARIZED CERAMIC CAPACITOR
RN	METAL FILM RESISTOR (1P-35)	CC	NON-POLARIZED CERAMIC CAPACITOR
RO	METAL FILM RESISTOR (1P-36)	CC	NON-POLARIZED CERAMIC CAPACITOR
RP	METAL FILM RESISTOR (1P-37)	CC	NON-POLARIZED CERAMIC CAPACITOR
RQ	METAL FILM RESISTOR (1P-38)	CC	NON-POLARIZED CERAMIC CAPACITOR
RR	METAL FILM RESISTOR (1P-39)	CC	NON-POLARIZED CERAMIC CAPACITOR
RS	METAL FILM RESISTOR (1P-40)	CC	NON-POLARIZED CERAMIC CAPACITOR
RT	METAL FILM RESISTOR (1P-41)	CC	NON-POLARIZED CERAMIC CAPACITOR
RU	METAL FILM RESISTOR (1P-42)	CC	NON-POLARIZED CERAMIC CAPACITOR
RV	METAL FILM RESISTOR (1P-43)	CC	NON-POLARIZED CERAMIC CAPACITOR
RW	METAL FILM RESISTOR (1P-44)	CC	NON-POLARIZED CERAMIC CAPACITOR
RX	METAL FILM RESISTOR (1P-45)	CC	NON-POLARIZED CERAMIC CAPACITOR
RY	METAL FILM RESISTOR (1P-46)	CC	NON-POLARIZED CERAMIC CAPACITOR
RZ	METAL FILM RESISTOR (1P-47)	CC	NON-POLARIZED CERAMIC CAPACITOR
RA	METAL FILM RESISTOR (1P-48)	CC	NON-POLARIZED CERAMIC CAPACITOR
RB	METAL FILM RESISTOR (1P-49)	CC	NON-POLARIZED CERAMIC CAPACITOR
RC	METAL FILM RESISTOR (1P-50)	CC	NON-POLARIZED CERAMIC CAPACITOR
RD	METAL FILM RESISTOR (1P-51)	CC	NON-POLARIZED CERAMIC CAPACITOR
RE	METAL FILM RESISTOR (1P-52)	CC	NON-POLARIZED CERAMIC CAPACITOR
RF	METAL FILM RESISTOR (1P-53)	CC	NON-POLARIZED CERAMIC CAPACITOR
RG	METAL FILM RESISTOR (1P-54)	CC	NON-POLARIZED CERAMIC CAPACITOR
RH	METAL FILM RESISTOR (1P-55)	CC	NON-POLARIZED CERAMIC CAPACITOR
RI	METAL FILM RESISTOR (1P-56)	CC	NON-POLARIZED CERAMIC CAPACITOR
RJ	METAL FILM RESISTOR (1P-57)	CC	NON-POLARIZED CERAMIC CAPACITOR
RK	METAL FILM RESISTOR (1P-58)	CC	NON-POLARIZED CERAMIC CAPACITOR
RL	METAL FILM RESISTOR (1P-59)	CC	NON-POLARIZED CERAMIC CAPACITOR
RM	METAL FILM RESISTOR (1P-60)	CC	NON-POLARIZED CERAMIC CAPACITOR
RN	METAL FILM RESISTOR (1P-61)	CC	NON-POLARIZED CERAMIC CAPACITOR
RO	METAL FILM RESISTOR (1P-62)	CC	NON-POLARIZED CERAMIC CAPACITOR
RP	METAL FILM RESISTOR (1P-63)	CC	NON-POLARIZED CERAMIC CAPACITOR
RQ	METAL FILM RESISTOR (1P-64)	CC	NON-POLARIZED CERAMIC CAPACITOR
RR	METAL FILM RESISTOR (1P-65)	CC	NON-POLARIZED CERAMIC CAPACITOR
RS	METAL FILM RESISTOR (1P-66)	CC	NON-POLARIZED CERAMIC CAPACITOR
RT	METAL FILM RESISTOR (1P-67)	CC	NON-POLARIZED CERAMIC CAPACITOR
RU	METAL FILM RESISTOR (1P-68)	CC	NON-POLARIZED CERAMIC CAPACITOR
RV	METAL FILM RESISTOR (1P-69)	CC	NON-POLARIZED CERAMIC CAPACITOR
RW	METAL FILM RESISTOR (1P-70)	CC	NON-POLARIZED CERAMIC CAPACITOR
RX	METAL FILM RESISTOR (1P-71)	CC	NON-POLARIZED CERAMIC CAPACITOR
RY	METAL FILM RESISTOR (1P-72)	CC	NON-POLARIZED CERAMIC CAPACITOR
RZ	METAL FILM RESISTOR (1P-73)	CC	NON-POLARIZED CERAMIC CAPACITOR
RA	METAL FILM RESISTOR (1P-74)	CC	NON-POLARIZED CERAMIC CAPACITOR
RB	METAL FILM RESISTOR (1P-75)	CC	NON-POLARIZED CERAMIC CAPACITOR
RC	METAL FILM RESISTOR (1P-76)	CC	NON-POLARIZED CERAMIC CAPACITOR
RD	METAL FILM RESISTOR (1P-77)	CC	NON-POLARIZED CERAMIC CAPACITOR
RE	METAL FILM RESISTOR (1P-78)	CC	NON-POLARIZED CERAMIC CAPACITOR
RF	METAL FILM RESISTOR (1P-79)	CC	NON-POLARIZED CERAMIC CAPACITOR
RG	METAL FILM RESISTOR (1P-80)	CC	NON-POLARIZED CERAMIC CAPACITOR
RH	METAL FILM RESISTOR (1P-81)	CC	NON-POLARIZED CERAMIC CAPACITOR
RI	METAL FILM RESISTOR (1P-82)	CC	NON-POLARIZED CERAMIC CAPACITOR
RJ	METAL FILM RESISTOR (1P-83)	CC	NON-POLARIZED CERAMIC CAPACITOR
RK	METAL FILM RESISTOR (1P-84)	CC	NON-POLARIZED CERAMIC CAPACITOR
RL	METAL FILM RESISTOR (1P-85)	CC	NON-POLARIZED CERAMIC CAPACITOR
RM	METAL FILM RESISTOR (1P-86)	CC	NON-POLARIZED CERAMIC CAPACITOR
RN	METAL FILM RESISTOR (1P-87)	CC	NON-POLARIZED CERAMIC CAPACITOR
RO	METAL FILM RESISTOR (1P-88)	CC	NON-POLARIZED CERAMIC CAPACITOR
RP	METAL FILM RESISTOR (1P-89)	CC	NON-POLARIZED CERAMIC CAPACITOR
RQ	METAL FILM RESISTOR (1P-90)	CC	NON-POLARIZED CERAMIC CAPACITOR
RR	METAL FILM RESISTOR (1P-91)	CC	NON-POLARIZED CERAMIC CAPACITOR
RS	METAL FILM RESISTOR (1P-92)	CC	NON-POLARIZED CERAMIC CAPACITOR
RT	METAL FILM RESISTOR (1P-93)	CC	NON-POLARIZED CERAMIC CAPACITOR
RU	METAL FILM RESISTOR (1P-94)	CC	NON-POLARIZED CERAMIC CAPACITOR
RV	METAL FILM RESISTOR (1P-95)	CC	NON-POLARIZED CERAMIC CAPACITOR
RW	METAL FILM RESISTOR (1P-96)	CC	NON-POLARIZED CERAMIC CAPACITOR
RX	METAL FILM RESISTOR (1P-97)	CC	NON-POLARIZED CERAMIC CAPACITOR
RY	METAL FILM RESISTOR (1P-98)	CC	NON-POLARIZED CERAMIC CAPACITOR
RZ	METAL FILM RESISTOR (1P-99)	CC	NON-POLARIZED CERAMIC CAPACITOR
RA	METAL FILM RESISTOR (1P-100)	CC	NON-POLARIZED CERAMIC CAPACITOR

NOTICE (mode)  
 (J) JAPANESE  
 (U) U.S.A.  
 (C) CANADIAN  
 (G) GENERAL  
 (A) AUSTRALIAN  
 (M) MALAYSIAN  
 (I) INDONESIAN  
 (K) KOREAN

- ★ All voltages are measured with a 10M Ω DC electric volt meter.
- ★ Components having special characteristics are marked (▲), and must be replaced with parts having specifications equal to those originally installed.
- ★ Schematic diagram is subject to change without notice.
- 電圧は、内部抵抗10MΩの電圧計で測定したものです。
- ▲印のある部品は、安全性確保部品を示しています。部品の交換が必要な場合、パーツリストに記載されている部品を使用してください。
- 本回路図は標準回路図です。改良のため予告なく変更することがございます。

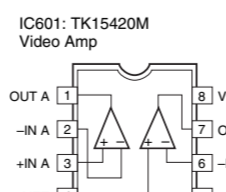

Production of the parts marked with "x" has been discontinued starting with November production of 2001.  
 ×マークの付いた部品は、2001年11月生産分より廃止されています。

RESISTOR	PARTS NAME	CAPACITOR	PARTS NAME
R1	10K	CC1	100P
R2	10K	CC2	100P
R3	10K	CC3	100P
R4	10K	CC4	100P
R5	10K	CC5	100P
R6	10K	CC6	100P
R7	10K	CC7	100P
R8	10K	CC8	100P
R9	10K	CC9	100P
R10	10K	CC10	100P
R11	10K	CC11	100P
R12	10K	CC12	100P
R13	10K	CC13	100P
R14	10K	CC14	100P
R15	10K	CC15	100P
R16	10K	CC16	100P
R17	10K	CC17	100P
R18	10K	CC18	100P
R19	10K	CC19	100P
R20	10K	CC20	100P
R21	10K	CC21	100P
R22	10K	CC22	100P
R23	10K	CC23	100P
R24	10K	CC24	100P
R25	10K	CC25	100P
R26	10K	CC26	100P
R27	10K	CC27	100P
R28	10K	CC28	100P
R29	10K	CC29	100P
R30	10K	CC30	100P
R31	10K	CC31	100P
R32	10K	CC32	100P
R33	10K	CC33	100P
R34	10K	CC34	100P
R35	10K	CC35	100P
R36	10K	CC36	100P
R37	10K	CC37	100P
R38	10K	CC38	100P
R39	10K	CC39	100P
R40	10K	CC40	100P
R41	10K	CC41	100P
R42	10K	CC42	100P
R43	10K	CC43	100P
R44	10K	CC44	100P
R45	10K	CC45	100P
R46	10K	CC46	100P
R47	10K	CC47	100P
R48	10K	CC48	100P
R49	10K	CC49	100P
R50	10K	CC50	100P
R51	10K	CC51	100P
R52	10K	CC52	100P
R53	10K	CC53	100P
R54	10K	CC54	100P
R55	10K	CC55	100P
R56	10K	CC56	100P
R57	10K	CC57	100P
R58	10K	CC58	100P
R59	10K	CC59	100P
R60	10K	CC60	100P
R61	10K	CC61	100P
R62	10K	CC62	100P
R63	10K	CC63	100P
R64	10K	CC64	100P
R65	10K	CC65	100P
R66	10K	CC66	100P
R67	10K	CC67	100P
R68	10K	CC68	100P
R69	10K	CC69	100P
R70	10K	CC70	100P
R71	10K	CC71	100P
R72	10K	CC72	100P
R73	10K	CC73	100P
R74	10K	CC74	100P
R75	10K	CC75	100P
R76	10K	CC76	100P
R77	10K	CC77	100P
R78	10K	CC78	100P
R79	10K	CC79	100P
R80	10K	CC80	100P
R81	10K	CC81	100P
R82	10K	CC82	100P
R83	10K	CC83	100P
R84	10K	CC84	100P
R85	10K	CC85	100P
R86	10K	CC86	100P
R87	10K	CC87	100P
R88	10K	CC88	100P
R89	10K	CC89	100P
R90	10K	CC90	100P
R91	10K	CC91	100P
R92	10K	CC92	100P
R93	10K	CC93	100P
R94	10K		

# SCHEMATIC DIAGRAM (MAIN)

The voltage value before or above parentheses [ ] is applicable to RX-V1200/RX-V1200RDS/HTR-5490/DSP-AX1200 and the value in the parentheses is applicable to RX-V2200/DSP-AX2200. Also, the voltage value without parentheses is commonly applicable to all models.

[ ]外の電圧値はRX-V1200/RX-V1200RDS/HTR-5490/DSP-AX1200の値を表し、[ ]内の電圧値はRX-V2200/DSP-AX2200の値を表します。また、[ ]が付いていない電圧値は全モデルに共通の値です。

RX-V1200/RX-V1200RDS/HTR-5490/DSP-AX1200/RX-V2200/DSP-AX2200

REMARKS	PARTS NAME
NO MARK	ELECTROLYTIC CAPACITOR
⊗	TANTALUM CAPACITOR
NO MARK	CERAMIC CAPACITOR
⊙	CERAMIC TUBULAR CAPACITOR
⊖	POLYESTER FILM CAPACITOR
○	POLYESTER FILM CAPACITOR
⊕	MICA CAPACITOR
⊖	POLYPROPYLENE FILM CAPACITOR
⊙	SEMICONDUCTIVE CERAMIC CAPACITOR
⊖	POLYPHENYLENE SULFIDE FILM CAPACITOR

REMARKS	PARTS NAME
NO MARK	CARBON FILM RESISTOR (P=5)
□	CARBON FILM RESISTOR (P=10)
△	METAL OXIDE FILM RESISTOR
⊗	METAL FILM RESISTOR
⊖	METAL PLATE RESISTOR
⊕	FIRE PROOF CARBON FILM RESISTOR
□	CEMENT MOLDED RESISTOR
⊖	SEMI VARIABLE RESISTOR
⊖	CHIP RESISTOR

NOTICE (model)  
 (J)..... JAPANESE  
 (U)..... U.S.A.  
 (C)..... CANADIAN  
 (R)..... GENERAL  
 (A)..... AUSTRALIAN  
 (B)..... BRITISH  
 (G)..... EUROPEAN  
 (T)..... CHINA  
 (K)..... KOREA

Interchangeable Parts at Manufacture Stage

Mark	Reference Parts Number	Parts Name
41	G4B-49	2SC2878(A/B) 2SC1815P(L/T)
42	RY.6	DH2402-DT1M1-SL DH2402-DT1M1
43	D1.4.13.14	HSS104 15S133 15S176

R.T.A	RX-V1200/RX-V1200RDS/HTR-5490/DSP-AX1200				RX-V2200/DSP-AX2200			
	J	U-C	R.T.K.A	B-G	J	U-C	R.T.A	R.T.A
R132	X	X	10	10	10	10	10	10
R153	X	X	4.7K	4.7K	4.7K	4.7K	4.7K	
Q40	X	X	9941(P,Q)	9941(P,Q)	9941(P,Q)	9941(P,Q)	9941(P,Q)	
R127	X	X	3.3K	3.3K	3.3K	3.3K	3.3K	
R122	X	X	100	100	100	100	100	
C47	X	X	10/25	10/25	10/25	10/25	10/25	
D18	X	X	MTZ24C	MTZ24C	MTZ24C	MTZ24C	MTZ24C	
R12B-R129	X	X	6.8K	6.8K	6.8K	6.8K	6.8K	
R189	X	X	1P10	1P10	1P10	1P10	1P10	
C3B-C89	X	X	100/50	100/50	100/50	100/50	100/50	
Q43	X	X	C1815(Y)	C1815(Y)	C1815(Y)	C1815(Y)	C1815(Y)	
TE1-TE2	V591230	V591220	V591230	V591220	V591230	V591220	V591230	
C75-C77	X	X	0.015	0.022	X	X	0.015	
C76-C78	X	X	0.01	0.01	X	X	0.01	
C79-C80-C81	X	X	4700P	4700P	X	X	4700P	
C82-C84-C88	X	X	10/50	10/50	10/50	10/50	10/50	
W11	X	X	MH39640	MH39640	MH39640	MH39640	MH39640	
SW1	X	X	SL14-22AMPF	SL14-22AMPF	SL14-22AMPF	SL14-22AMPF	SL14-22AMPF	
W12	X	X	MH31640	MH31640	X	MH31640	MH31640	
W19	X	X	MH34630	MH34630	MH34630	MH34630	MH34630	
W20	X	X	MH33630	MH33630	X	MH33630	MH33630	
C65	X	X	4700P	0.01	X	X	4700P	
W13	X	X	MH31640	MH31640	X	MH31640	MH31640	
R10, 11, 21, 31	1/2P 820	1/2P 820	1/2P 820	1/2P 820	1/2P 1K	1/2P 1K	1/2P 1K	
R34, 35, 37, 39, 40	1/2P 1K	1/2P 1K	1/2P 1K	1/2P 1K	1/2P 820	1/2P 820	1/2P 820	
Q1A, 1K, 2A, 3A, 3C, 3A, 3C, 3A, 3C	A1695C4468	A1695C4468	A1695C4468	A1695C4468	A1482C366 (G, P)	A1482C366 (G, P)	A1482C366 (G, P)	

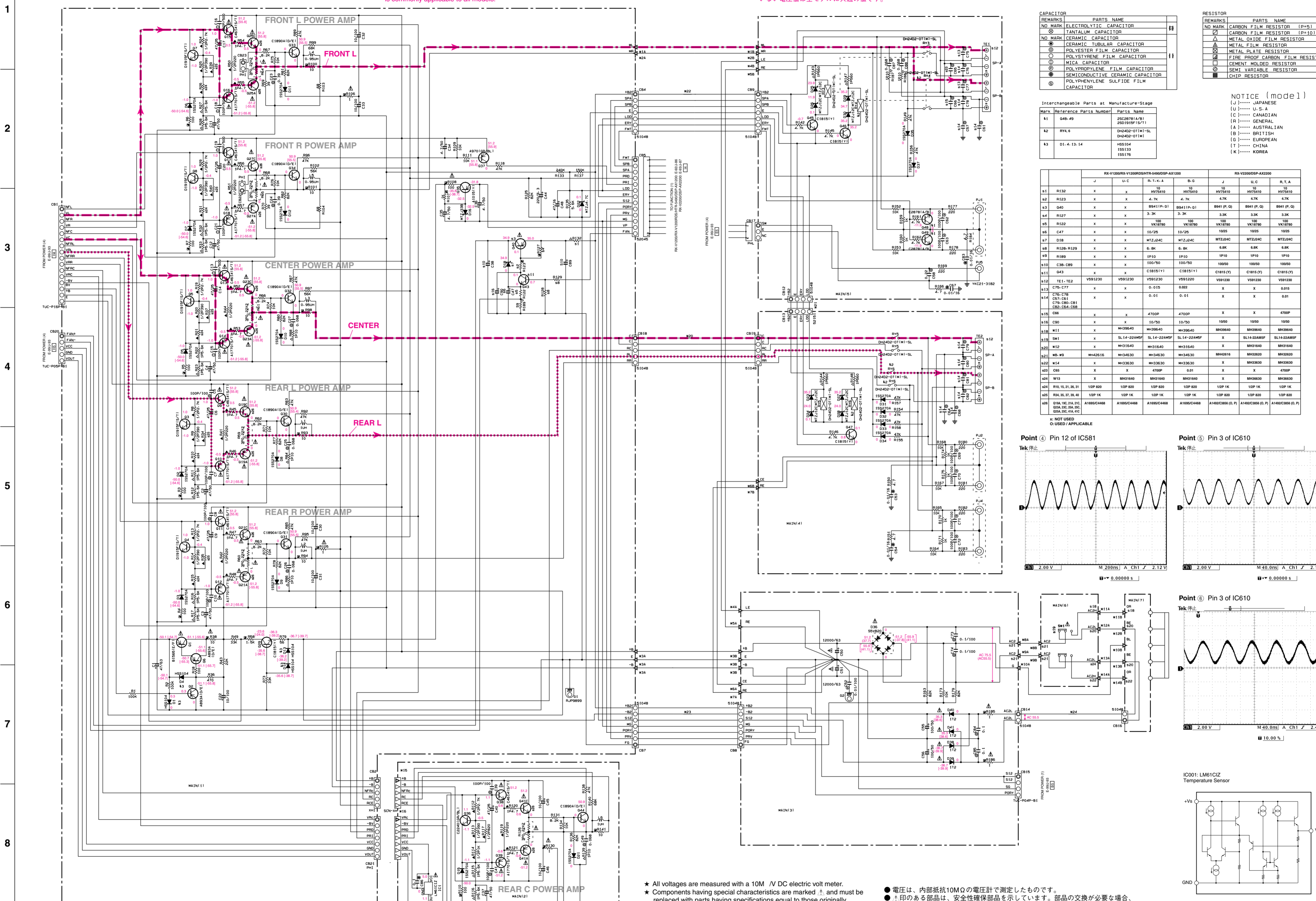
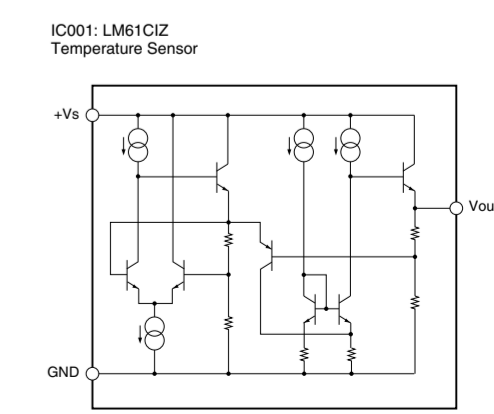
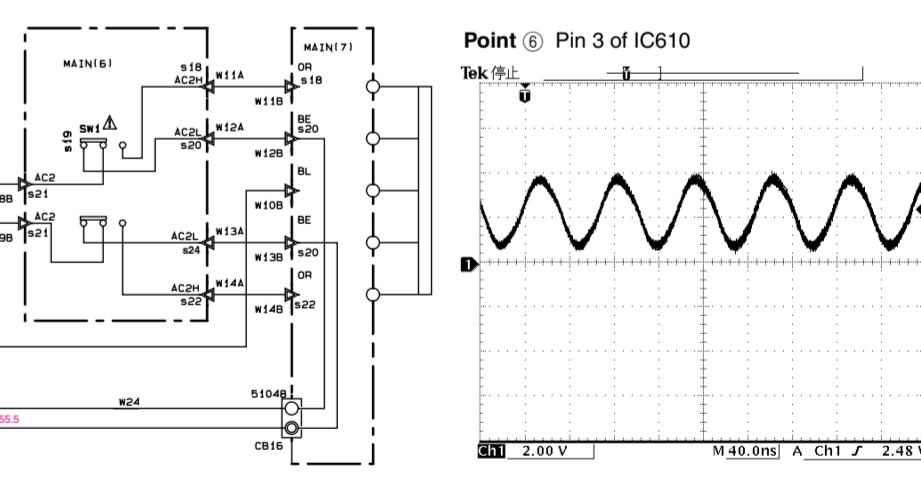
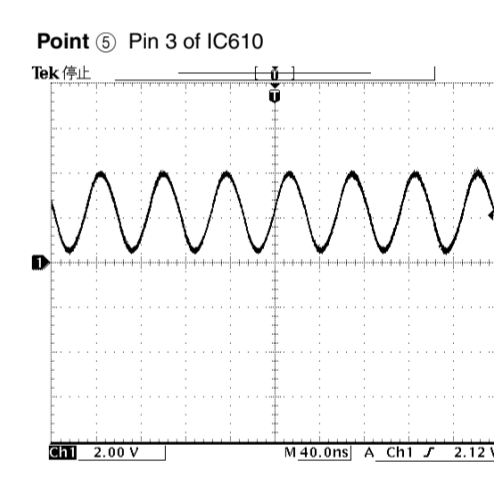
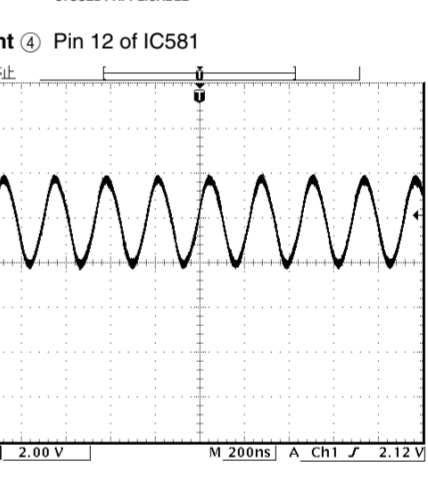

★ All voltages are measured with a 10M  $\Omega$  DC electric volt meter.  
 ★ Components having special characteristics are marked  $\Delta$  and must be replaced with parts having specifications equal to those originally installed.  
 ★ Schematic diagram is subject to change without notice.

● 電圧は、内部抵抗10M $\Omega$ の電圧計で測定したものです。  
 ●  $\Delta$ 印のある部品は、安全性確保部品を示しています。部品の交換が必要な場合、パーツリストに記載されている部品を使用してください。  
 ● 本回路図は標準回路図です。改良のため予告なく変更することがございます。

# SCHEMATIC DIAGRAM (POWER)

RESISTOR	PARTS NAME
REMARKS	
NO MARK	CARBON FILM RESISTOR (P=5)
□	CARBON FILM RESISTOR (P=10)
△	METAL OXIDE FILM RESISTOR
▴	METAL FILM RESISTOR
◇	METAL PLATE RESISTOR
◇	FINE PRINT CARBON FILM RESISTOR
□	CEMENT MOLDED RESISTOR
◇	SEMI VARIABLE RESISTOR
■	CHIP RESISTOR

CAPACITOR	PARTS NAME
REMARKS	
NO MARK	ELECTROLYTIC CAPACITOR
⊙	TANTALUM CAPACITOR
□	CERAMIC CAPACITOR
⊗	CERAMIC TUBULAR CAPACITOR
⊙	POLYESTER FILM CAPACITOR
○	POLYETHYLENE FILM CAPACITOR
◇	MICA CAPACITOR
⊙	POLYPROPYLENE FILM CAPACITOR
⊗	SEMICONDUCTIVE CERAMIC CAPACITOR
⊙	POLYPHENYLENE SULFIDE FILM CAPACITOR

NOTICE (mode1)  
 (J)..... JAPANESE  
 (U)..... U. S. A  
 (C)..... CANADIAN  
 (F)..... GENERAL  
 (A)..... AUSTRALIAN  
 (B)..... BRITISH  
 (G)..... EUROPEAN  
 (T)..... CHINA  
 (K)..... KOREA

The voltage value before or above parentheses ( ) is applicable to RX-V1200/RX-V1200RDS/HTR-5490/DSP-AX1200 and the value in the parentheses is applicable to RX-V2200/DSP-AX2200. Also, the voltage value without parentheses is commonly applicable to all models.

[ ]内の電圧値はRX-V1200/RX-V1200RDS/HTR-5490/DSP-AX1200の値を表し、[ ]内の電圧値はRX-V2200/DSP-AX2200の値を表します。また、[ ]が付いていない電圧値は全モデルに共通の値です。

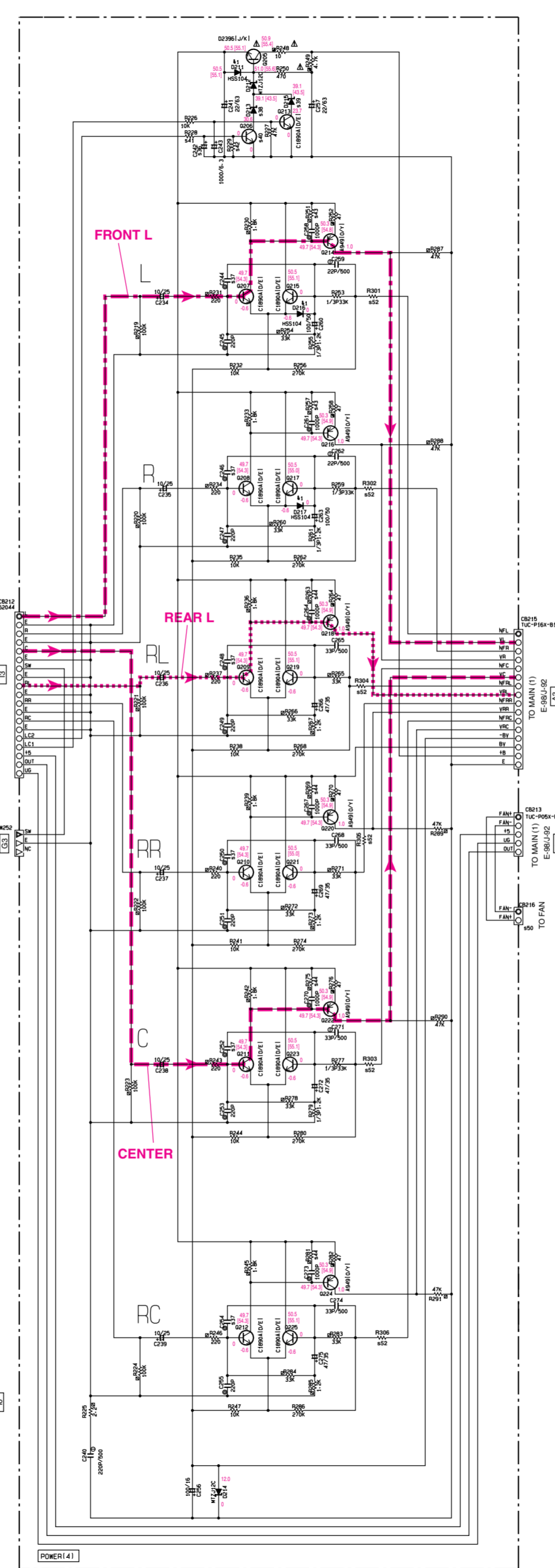
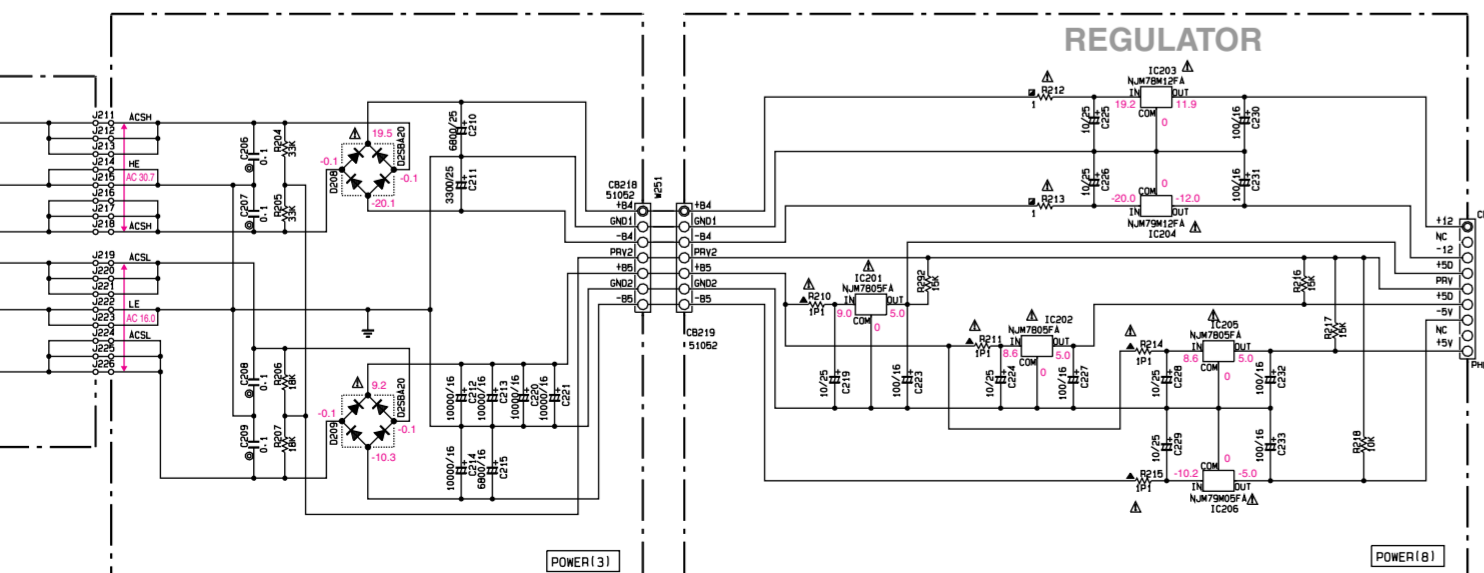
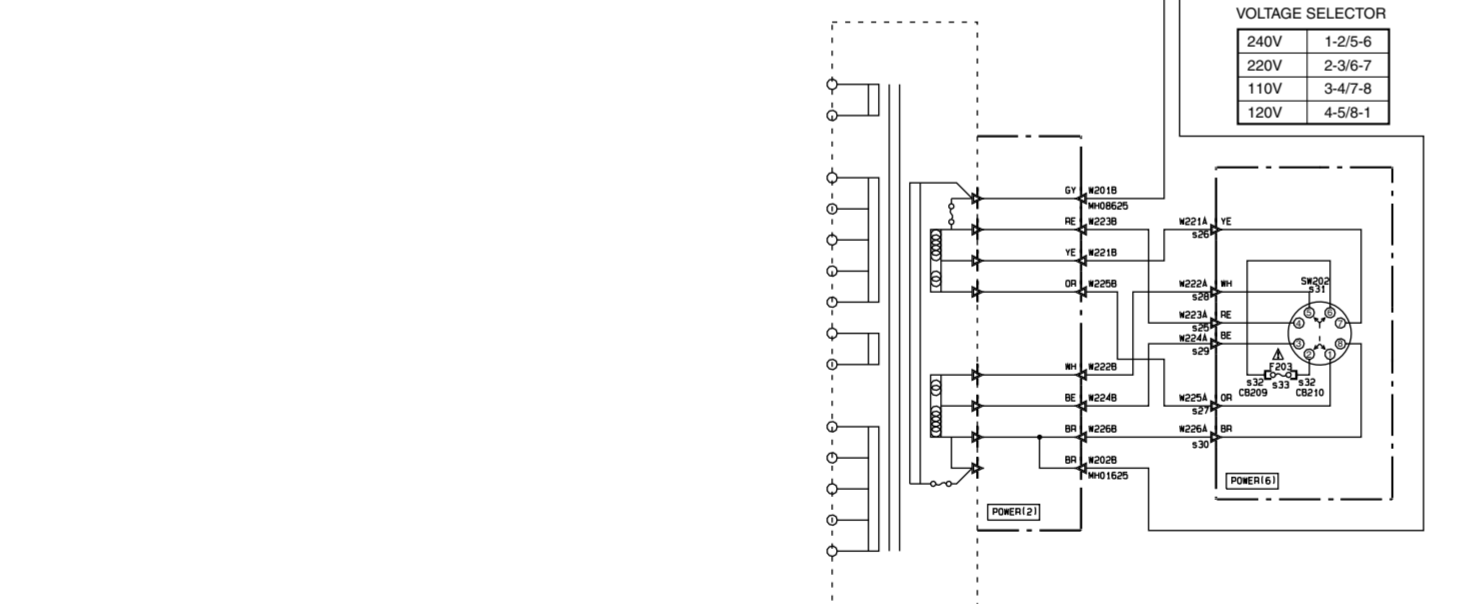
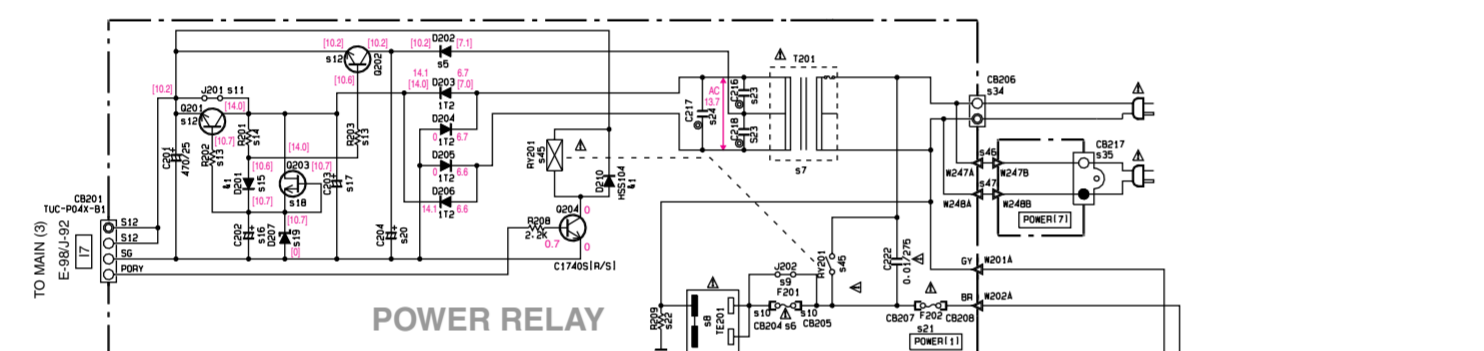
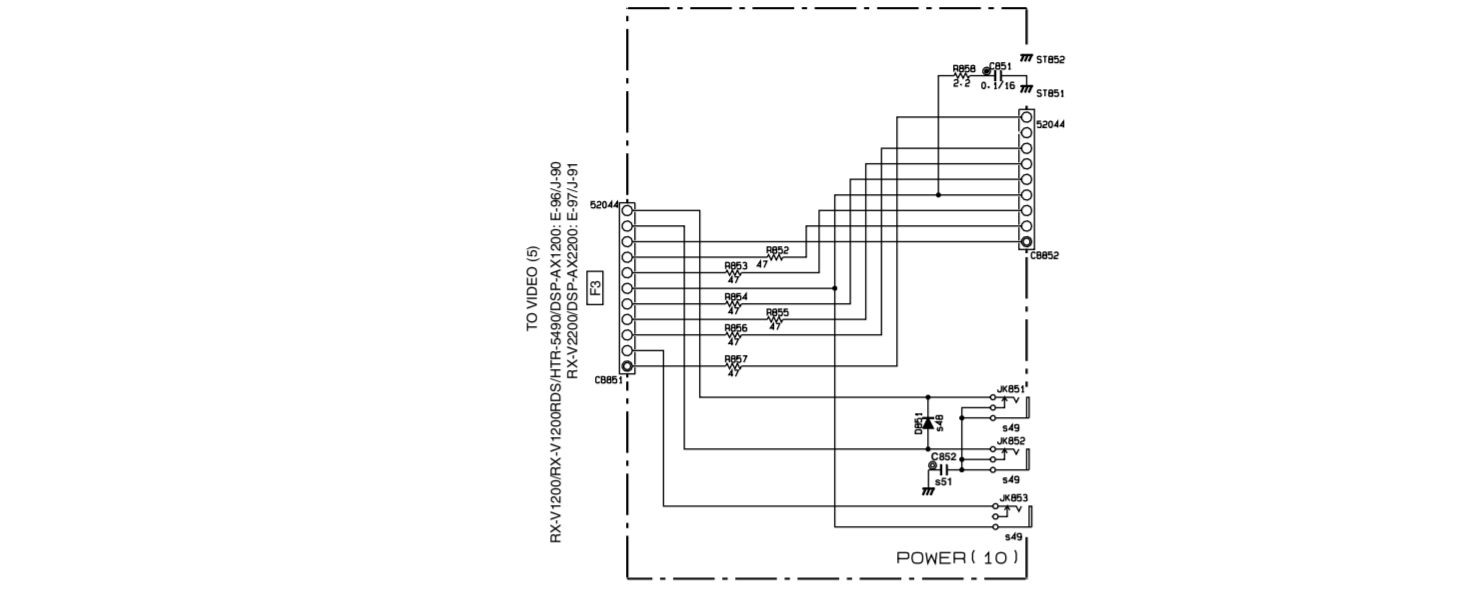

PART NO.	RX-V1200/RX-V1200RDS/HTR-5490/DSP-AX1200										RX-V2200/DSP-AX2200							
	J	U	C	A	B	G	J	U	C	A	B	G	J	U	C	A	B	G
95 D002	x	x	x	x	x	x	x	x	x	x	x	x	x	x	x	x	x	x
96 F301	x	BA125V V58230	x	x	x	x	12-34K25V V14201	x	x	x	x	BA125V V58230	x	x	x	x	x	x
97 J201	x2227	x2228	x2228	x2228	x2229	x2230	x2231	x2231	x2227	x2228	x2228	x2229	x2230	x2230	x2230	x2230	x2230	
98 TE201	V64310	V64310	V64310	V64310	V79100	V64330	V64340	V64310	V64310	V64310	V64310	V64310	V64310	V64310	V64310	V64310	V79100	
99 J002	0	0	0	0	0	0	0	0	0	0	0	0	0	0	0	0	0	
100 CB004-205	x	VP2050	x	x	x	x	x	VP2050	x	VP2050	x	x	x	x	x	x	x	
101 J001	0	0	0	0	0	0	0	0	0	0	0	0	0	0	0	0	0	
102 J201-202	x	x	x	x	03961 LxK1 V51205	x	x	x	x	x	x	x	x	x	x	03961 LxK1 V51205	x	
103 R002-203	x	x	x	x	100 HF4510	x	x	x	x	x	x	x	x	x	x	100 HF4510	x	
104 R001	x	x	x	x	10K HF4510	x	x	x	x	x	x	x	x	x	x	10K HF4510	x	
105 D001	x	x	x	x	15S133 V053155	x	x	x	x	x	x	x	x	x	x	15S133 V053155	x	
106 C202	x	x	x	x	10/25 V04715	x	x	x	x	x	x	x	x	x	x	10/25 V04715	x	
107 C203	x	x	x	x	15/100 V059120	x	x	x	x	x	x	x	x	x	x	15/100 V059120	x	
108 R003	x	x	x	x	K241(V) IE10262	x	x	x	x	x	x	x	x	x	x	K241(V) IE10262	x	
109 D007	x	x	x	x	MTZ115B V04390	x	x	x	x	x	x	x	x	x	x	MTZ115B V04390	x	
110 C204	x	x	x	x	15/70 V04810	x	x	x	x	x	x	x	x	x	x	15/70 V04810	x	
121 F202	BA125V V58230	BA125V V58230	BA125V V58230	BA125V V58230	14AL250V KB0079	14AL250V KB0079	14AL250V KB0079	14AL250V KB0079	BA125V V58230	BA125V V58230	BA125V V58230	BA125V V58230	BA125V V58230	BA125V V58230	BA125V V58230	14AL250V KB0079	14AL250V KB0079	
122 R009	x	1/200 W V67300	1/200 W V67300	1/200 W V67300	x	x	x	x	x	x	x	x	x	x	x	1/200 W V67300	1/200 W V67300	
123 C216-218	x	x	x	x	0.01 V17300	x	x	x	x	x	x	x	x	x	x	0.01 V17300	x	
124 C217	0.01/100 V05410	0.01/100 V05410	0.01/100 V05410	x	0.01/100 V05410	0.01/100 V05410	0.01/100 V05410	0.01/100 V05410	0.01/100 V05410	0.01/100 V05410	0.01/100 V05410	0.01/100 V05410	0.01/100 V05410	0.01/100 V05410	x	0.01/100 V05410		
125 R023	x	x	x	x	MH0630	x	x	x	x	x	x	x	x	x	x	MH0630	x	
126 R021	x	x	x	x	MH0430	x	x	x	x	x	x	x	x	x	x	MH0430	x	
127 R025	x	x	x	x	MH0330	x	x	x	x	x	x	x	x	x	x	MH0330	x	
128 R022	x	x	x	x	MH0930	x	x	x	x	x	x	x	x	x	x	MH0930	x	
129 R024	x	x	x	x	MH0630	x	x	x	x	x	x	x	x	x	x	MH0630	x	
130 R026	x	x	x	x	MH0130	x	x	x	x	x	x	x	x	x	x	MH0130	x	
131 3K202	x	x	x	x	V718230	x	x	x	x	x	x	x	x	x	x	V718230	x	
132 CB209-210	x	x	x	x	VP2050	x	x	x	x	x	x	x	x	x	x	VP2050	x	
133 F203	x	x	x	x	14AL250V KB0079	x	x	x	x	x	x	x	x	x	x	14AL250V KB0079	x	
134 CB206	V58790	x	x	x	V58790	V58790	V58790	V58790	V58790	V58790	V58790	V58790	V58790	V58790	V58790	V58790	V58790	
135 CB217	x	V056120	V056120	x	x	x	x	x	V056120	V056120	V056120	V056120	x	x	x	V056120	x	
136 C242	x	1000/6.3 V081910	1000/6.3 V081910	1000/6.3 V081910	1000/6.3 V081910	1000/6.3 V081910	1000/6.3 V081910	1000/6.3 V081910	x	1000/6.3 V081910	1000/6.3 V081910	1000/6.3 V081910	1000/6.3 V081910	1000/6.3 V081910	1000/6.3 V081910	1000/6.3 V081910	1000/6.3 V081910	
137 C244-246-252	100P V05450	100P V05450	100P V05450	100P V05450	100P V05450	100P V05450	100P V05450	100P V05450	100P V05450	100P V05450	100P V05450	100P V05450	100P V05450	100P V05450	100P V05450	100P V05450	100P V05450	
138 C248-250-254	100P V05450	100P V05450	100P V05450	100P V05450	100P V05450	100P V05450	100P V05450	100P V05450	100P V05450	100P V05450	100P V05450	100P V05450	100P V05450	100P V05450	100P V05450	100P V05450	100P V05450	
139 R013	x	W72-1A V643910	W72-1A V643910	W72-1A V643910	W72-1A V643910	W72-1A V643910	W72-1A V643910	W72-1A V643910	x	W72-1A V643910	W72-1A V643910	W72-1A V643910	W72-1A V643910	W72-1A V643910	W72-1A V643910	W72-1A V643910	W72-1A V643910	
139 D215	MTZ115B V04390	MTZ115B V04390	MTZ115B V04390	MTZ115B V04390	MTZ115B V04390	MTZ115B V04390	MTZ115B V04390	MTZ115B V04390	MTZ115B V04390	MTZ115B V04390	MTZ115B V04390	MTZ115B V04390	MTZ115B V04390	MTZ115B V04390	MTZ115B V04390	MTZ115B V04390	MTZ115B V04390	
140 R006	x	C189A1(D/E) V08310	C189A1(D/E) V08310	C189A1(D/E) V08310	C189A1(D/E) V08310	C189A1(D/E) V08310	C189A1(D/E) V08310	C189A1(D/E) V08310	C189A1(D/E) V08310	C189A1(D/E) V08310	C189A1(D/E) V08310	C189A1(D/E) V08310	C189A1(D/E) V08310	C189A1(D/E) V08310	C189A1(D/E) V08310	C189A1(D/E) V08310	C189A1(D/E) V08310	
141 R028	x	10K HF4510	10K HF4510	10K HF4510	10K HF4510	10K HF4510	10K HF4510	10K HF4510	x	10K HF4510	10K HF4510	10K HF4510	10K HF4510	10K HF4510	10K HF4510	10K HF4510	10K HF4510	
142 R009	x	47K HF4510	47K HF4510	47K HF4510	47K HF4510	47K HF4510	47K HF4510	47K HF4510	x	47K HF4510	47K HF4510	47K HF4510	47K HF4510	47K HF4510	47K HF4510	47K HF4510	47K HF4510	
143 R051-257	x	47K HC05015	47K HC05015	47K HC05015	47K HC05015	47K HC05015	47K HC05015	47K HC05015	47K HC05015	47K HC05015	47K HC05015	47K HC05015	47K HC05015	47K HC05015	47K HC05015	47K HC05015	47K HC05015	
144 R063-269	150 HC05015	150 HC05015	150 HC05015	150 HC05015	150 HC05015	150 HC05015	150 HC05015	150 HC05015	150 HC05015	150 HC05015	150 HC05015	150 HC05015	150 HC05015	150 HC05015	150 HC05015	150 HC05015	150 HC05015	
144 R075-281	150 HC05015	150 HC05015	150 HC05015	150 HC05015	150 HC05015	150 HC05015	150 HC05015	150 HC05015	150 HC05015	150 HC05015	150 HC05015	150 HC05015	150 HC05015	150 HC05015	150 HC05015	150 HC05015	150 HC05015	
145 R101	150 V081740 V083930	150 V081740 V083930	150 V081740 V083930	150 V081740 V083930	150 V081740 V083930	150 V081740 V083930	150 V081740 V083930	150 V081740 V083930	150 V081740 V083930	150 V081740 V083930	150 V081740 V083930	150 V081740 V083930	150 V081740 V083930	150 V081740 V083930	150 V081740 V083930	150 V081740 V083930	150 V081740 V083930	
146 R247	x	MH0612	MH0612	x	x	x	x	x	MH0612	MH0612	MH0612	MH0612	x	x	x	MH0612	x	
147 R248	x	MH0612	MH0612	x	x	x	x	x	MH0612	MH0612	MH0612	MH0612	x	x	x	MH0612	x	
148 R051	x	15S133	15S133	x	15S133	x	x	x	x	15S133	15S133	15S133	15S133	15S133	15S133	15S133	15S133	
149 J051-052-053	x	VJ72680	VJ72680	x	VJ72680	x	x	x	x	VJ72680	VJ72680	VJ72680	VJ72680	VJ72680	VJ72680	VJ72680	VJ72680	
150 C016	x	x	x	x	PHI V83980	PHI V83980	PHI V83980	PHI V83980	x	PHI V83980	PHI V83980	PHI V83980	PHI V83980	PHI V83980	PHI V83980	PHI V83980	PHI V83980	
151 C052	x	1000P V04700	1000P V04700	x	1000P V04700	x	x	x	x	1000P V04700	1000P V04700	1000P V04700	1000P V04700	1000P V04700	1000P V04700	1000P V04700	1000P V04700	
152 R301-306	HF45310	HF45310	HF45310	HF45310	HF45310	HF45310	HF45310	HF45310	HF45310	HF45310	HF45310	HF45310	HF45310	HF45310	HF45310	HF45310	HF45310	

NOT USED

USED / APPLICABLE

Mark	Reference	Parts Number	Parts Name
41	0001,210,211,216,217	H05104	
		15S133	
		15S133	

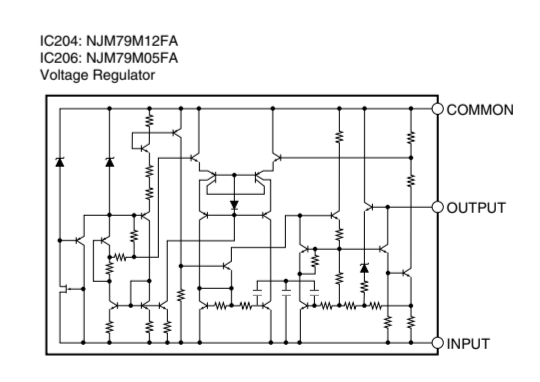
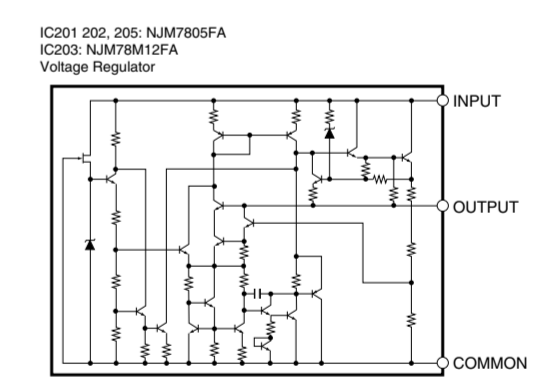

- All voltages are measured with a 10M Ω DC electric voltmeter.
- Components having special characteristics are marked  $\Delta$  and must be replaced with parts having specifications equal to those originally installed.
- Schematic diagram is subject to change without notice.

- 電圧は、内部抵抗10MΩの電圧計で測定したものです。
- $\Delta$ 印のある部品は、安全性確保部品を示しています。部品の交換が必要な場合、パーツリストに記載されている部品を使用してください。
- 本回路図は標準回路図です。改良のため予告なく変更することがございます。

# PARTS LIST

## ■ ELECTRICAL PARTS

### ■ WARNING

RX-V1200/RX-V1200RDS/HTR-5490/RX-V2200

Components having special characteristics are marked  $\Delta$  and must be replaced with parts having specifications equal to those originally installed.

- Carbon resistors (1/6W or 1/4W) are not included in the ELECTRICAL PARTS List. For the parts No. of the carbon resistors, refer to last page.

### ABBREVIATIONS IN THIS LIST ARE AS FOLLOWS:

C.A.EL.CHP	: CHIP ALUMI.ELECTROLYTIC CAP	L.EMIT	: LIGHT EMITTING MODULE
C.CE	: CERAMIC CAP	LED.DSPLY	: LED DISPLAY
C.CE.ARRAY	: CERAMIC CAP ARRAY	LED.INFRD	: LED,INFRARED
C.CE.CHP	: CHIP CERAMIC CAP	MODUL.RF	: MODULATOR,RF
C.CE.ML	: MULTILAYER CERAMIC CAP	PHOT.CPL	: PHOTO COUPLER
C.CE.M.CHP	: CHIP MULTILAYER CERAMIC CAP	PHOT.INTR	: PHOTO INTERRUPTER
C.CE.SAFTY	: RECOGNIZED CERAMIC CAP	PHOT.RFLCT	: PHOTO REFLECTOR
C.CE.TUBLR	: CERAMIC TUBULAR CAP	PIN.TEST	: PIN,TEST POINT
C.CE.SMI	: SEMI CONDUCTIVE CERAMIC CAP	PLST.RIVET	: PLASTIC RIVET
C.EL	: ELECTROLYTIC CAP	R.ARRAY	: RESISTOR ARRAY
C.MICA	: MICA CAP	R.CAR.	: CARBON RESISTOR
C.ML.FLM	: MULTILAYER FILM CAP	R.CAR.CHP	: CHIP RESISTOR
C.MP	: METALLIZED PAPER CAP	R.CAR.FP	: FLAME PROOF CARBON RESISTOR
C.MYLAR	: MYLAR FILM CAP	R.FUS	: FUSABLE RESISTOR
C.MYLAR.ML	: MULTILAYER MYLAR FILM CAP	R.MTL.CHP	: CHIP METAL FILM RESISTOR
C.PAPER	: PAPER CAPACITOR	R.MTL.FLM	: METAL FILM RESISTOR
C.PLS	: POLYSTYRENE FILM CAP	R.MTL.OXD	: METAL OXIDE FILM RESISTOR
C.POL	: POLYESTER FILM CAP	R.MTL.PLAT	: METAL PLATE RESISTOR
C.POLY	: POLYETHYLENE FILM CAP	RSNR.CE	: CERAMIC RESONATOR
C.PP	: POLYPROPYLENE FILM CAP	RSNR.CRYS	: CRYSTAL RESONATOR
C.TNTL	: TANTALUM CAP	R.TW.CEM	: TWIN CEMENT FIXED RESISTOR
C.TNTL.CHP	: CHIP TANTALUM CAP	R.WW	: WIRE WOUND RESISTOR
C.TRIM	: TRIMMER CAP	SCR.BND.HD	: BIND HEAD B-TITE SCREW
CN	: CONNECTOR	SCR.BW.HD	: BW HEAD TAPPING SCREW
CN.BS.PIN	: CONNECTOR,BASE PIN	SCR.CUP	: CUP TITE SCREW
CN.CANNON	: CONNECTOR,CANNON	SCR.TERM	: SCREW TERMINAL
CN.DIN	: CONNECTOR,DIN	SCR.TR	: SCREW,TRANSISTOR
CN.FLAT	: CONNECTOR,FLAT CABLE	SUPRT.PCB	: SUPPORT,P.C.B.
CN.POST	: CONNECTOR,BASE POST	SURG.PRTCT	: SURGE PROTECTOR
COIL.MX.AM	: COIL,AM MIX	SW.TACT	: TACT SWITCH
COIL.AT.FM	: COIL,FM ANTENNA	SW.LEAF	: LEAF SWITCH
COIL.DT.FM	: COIL,FM DETECT	SW.LEVER	: LEVER SWITCH
COIL.MX.FM	: COIL,FM MIX	SW.MICRO	: MICRO SWITCH
COIL.OUTPT	: OUTPUT COIL	SW.PUSH	: PUSH SWITCH
DIOD.ARRAY	: DIODE ARRAY	SW.RT.ENC	: ROTARY ENCODER
DIODE.BRG	: DIODE BRIDGE	SW.RT.MTR	: ROTARY SWITCH WITH MOTOR
DIODE.CHP	: CHIP DIODE	SW.RT	: ROTARY SWITCH
DIODE.SHOT	: SCHOTTKY BARRIER DIODE	SW.SLIDE	: SLIDE SWITCH
DIODE.VAR	: VARACTOR DIODE	TERM.SP	: SPEAKER TERMINAL
DIOD.Z.CHP	: CHIP ZENER DIODE	TERM.WRAP	: WRAPPING TERMINAL
DIODE.ZENR	: ZENER DIODE	THRMST.CHP	: CHIP THERMISTOR
DSCR.CE	: CERAMIC DISCRIMINATOR	TR.CHP	: CHIP TRANSISTOR
FER.BEAD	: FERRITE BEADS	TR.DGT	: DIGITAL TRANSISTOR
FER.CORE	: FERRITE CORE	TR.DGT.CHP	: CHIP DIGITAL TRANSISTOR
FET.CHP	: CHIP FET	TRANS	: TRANSFORMER
FL.DSPLY	: FLUORESCENT DISPLAY	TRANS.PULS	: PULSE TRANSFORMER
FLTR.CE	: CERAMIC FILTER	TRANS.PWR	: POWER TRANSFORMER ASS'Y
FLTR.COMB	: COMB FILTER MODULE	TUNER.AM	: TUNER PACK,AM
FLTR.LC.RF	: LC FILTER,EMI	TUNER.FM	: TUNER PACK,FM
GND.MTL	: GROUND PLATE	TUNER.PK	: FRONT-END TUNER PACK
GND.TERM	: GROUND TERMINAL	VR	: ROTARY POTENTIOMETER
HOLDER.FUS	: FUSE HOLDER	VR.MTR	: POTENTIOMETER WITH MOTOR
IC.PRTCT	: IC PROTECTOR	VR.SW	: POTENTIOMETER WITH ROTARY SW
JUMPER.CN	: JUMPER CONNECTOR	VR.SLIDE	: SLIDE POTENTIOMETER
JUMPER.TST	: JUMPER,TEST POINT	VR.TRIM	: TRIMMER POTENTIOMETER
L.DTCT	: LIGHT DETECTING MODULE		

**Note)** Those parts marked with “#” are not included in the P.C.B. ass'y.





**P.C.B. FUNCTION**

Schm Ref.	PART NO.	Description	Markets
C606	UP652470	C. POL 470pF 100V	
C607	UP652470	C. POL 470pF 100V	
C608	UP652470	C. POL 470pF 100V	
C609	UP652470	C. POL 470pF 100V	
C610	UP652470	C. POL 470pF 100V	
C611	UP652470	C. POL 470pF 100V	
C612	UP652470	C. POL 470pF 100V	
C613	UP652470	C. POL 470pF 100V	
C614	UP652470	C. POL 470pF 100V	
C615	UP652220	C. POL 220pF 100V	
C616	UP652220	C. POL 220pF 100V	
C617	UP652470	C. POL 470pF 100V	
C618	UP652470	C. POL 470pF 100V	
C619	UP652470	C. POL 470pF 100V	
C620	UP652470	C. POL 470pF 100V	
C621	UP652470	C. POL 470pF 100V	
C622	UP652470	C. POL 470pF 100V	
C623	UA654390	C. MYLAR 0.039uF 50V	
C624	UA654390	C. MYLAR 0.039uF 50V	
C625	UP652100	C. POL 100pF 100V	(V2200)
C626	UP652100	C. POL 100pF 100V	(V2200)
C627	UA654110	C. MYLAR 0.011uF 50V	
C628	UA654110	C. MYLAR 0.011uF 50V	
C629	UA653100	C. MYLAR 1000pF 50V	
C630	UA653100	C. MYLAR 1000pF 50V	
C631	UP652100	C. POL 100pF 100V	
C632	UP652100	C. POL 100pF 100V	
C633	US135100	C. CE. CHP 0.1uF 16V	
C634	US135100	C. CE. CHP 0.1uF 16V	
C635	UP654270	C. POL 0.027uF 100V	
C636	UP654270	C. POL 0.027uF 100V	
C637	UP654270	C. POL 0.027uF 100V	
C638	UP654270	C. POL 0.027uF 100V	
C639	US135100	C. CE. CHP 0.1uF 16V	
C640	UP652100	C. POL 100pF 100V	
C641	UP652100	C. POL 100pF 100V	
C642	US135100	C. CE. CHP 0.1uF 16V	
C643	US135100	C. CE. CHP 0.1uF 16V	
C644	US063100	C. CE. M. CHP 1000pF 50V	
C645	US135100	C. CE. CHP 0.1uF 16V	
C646	US135100	C. CE. CHP 0.1uF 16V	
C647	US135100	C. CE. CHP 0.1uF 16V	
C648	US135100	C. CE. CHP 0.1uF 16V	
C649	US135100	C. CE. CHP 0.1uF 16V	
C650	US135100	C. CE. CHP 0.1uF 16V	
C651	US135100	C. CE. CHP 0.1uF 16V	
C652	US135100	C. CE. CHP 0.1uF 16V	
C653	US135100	C. CE. CHP 0.1uF 16V	
C654	US135100	C. CE. CHP 0.1uF 16V	
C655	US135100	C. CE. CHP 0.1uF 16V	
C656	US135100	C. CE. CHP 0.1uF 16V	
C657	US135100	C. CE. CHP 0.1uF 16V	
C658	UP652100	C. POL 100pF 100V	
C659	UP652100	C. POL 100pF 100V	
C660	UP652100	C. POL 100pF 100V	
C661	US135100	C. CE. CHP 0.1uF 16V	
C662	UP652100	C. POL 100pF 100V	
C663	UP652100	C. POL 100pF 100V	
C664	US135100	C. CE. CHP 0.1uF 16V	
C665	US135100	C. CE. CHP 0.1uF 16V	
C666	US135100	C. CE. CHP 0.1uF 16V	
C667	UP652100	C. POL 100pF 100V	
C668	UP652100	C. POL 100pF 100V	

\* New Parts

Schm Ref.	PART NO.	Description	Markets
C669	US135100	C. CE. CHP 0.1uF 16V	
C670	US135100	C. CE. CHP 0.1uF 16V	
C671	US135100	C. CE. CHP 0.1uF 16V	UCABG
C672	US135100	C. CE. CHP 0.1uF 16V	
C673	US135100	C. CE. CHP 0.1uF 16V	
C675	US063100	C. CE. M. CHP 1000pF 50V	
C676	US135100	C. CE. CHP 0.1uF 16V	UCABG
C677	US063100	C. CE. M. CHP 1000pF 50V	
C678	US135100	C. CE. CHP 0.1uF 16V	UCABG
C679	US135100	C. CE. CHP 0.1uF 16V	RTKABG
C680	US135100	C. CE. CHP 0.1uF 16V	
C681	US135100	C. CE. CHP 0.1uF 16V	
C682	US135100	C. CE. CHP 0.1uF 16V	
C691	UR867470	C. EL 47uF 50V	
C692	UR848100	C. EL 100uF 25V	RTKABG
D501	VU992600	DIODE. ZENR MA8051-M 5.1V	
D502	VT332900	DIODE 1SS355	
D503	VT332900	DIODE 1SS355	
D504	VT332900	DIODE 1SS355	
D505	VT332900	DIODE 1SS355	
D506	VU992900	DIODE. ZENR MA8056-L 5.4V	RTK
D506	VU993500	DIODE. ZENR MA8062-H 6.4V	UCABG
D507	VT332900	DIODE 1SS355	
D508	VT332900	DIODE 1SS355	
D509	VT332900	DIODE 1SS355	
D510	VT332900	DIODE 1SS355	
D511	VV833200	DIODE 1SS380	
D512	VT332900	DIODE 1SS355	
D513	VU992600	DIODE. ZENR MA8051-M 5.1V	
D514	VT332900	DIODE 1SS355	
D515	VU993000	DIODE. ZENR MA8056-M 5.6V	
D517	VT332900	DIODE 1SS355	UCA
D518	VT332900	DIODE 1SS355	UCA
D519	VV220700	DIODE. SHOT RB501V-40	
D520	VT332900	DIODE 1SS355	
D521	VV220700	DIODE. SHOT RB501V-40	
D522	VT332900	DIODE 1SS355	
D523	VV220700	DIODE. SHOT RB501V-40	
D524	VT332900	DIODE 1SS355	
D525	VV220700	DIODE. SHOT RB501V-40	
D526	VT332900	DIODE 1SS355	
D531	VT332900	DIODE 1SS355	
D532	VT332900	DIODE 1SS355	
IC501	XJ553A00	IC NJM2068MD	
IC502	XP895A00	IC LC78212	
IC503	XP894A00	IC LC78211	
IC504	XP895A00	IC LC78212	(V2200)
IC505	XP896A00	IC LC78213	(V2200)
IC506	XF291A00	IC uPC4570G2	
IC507	XF291A00	IC uPC4570G2	
IC508	XF291A00	IC uPC4570G2	(V2200)
IC509	XP894A00	IC LC78211	
IC510	XP896A00	IC LC78213	
IC511	XF291A00	IC uPC4570G2	
IC512	X0601A00	IC MBM29F400BC-70	
IC513	XF291A00	IC uPC4570G2	
IC514	XF291A00	IC uPC4570G2	
IC515	XF291A00	IC uPC4570G2	
IC516	XZ545A00	IC YAC520-EE2	
IC517	XZ545A00	IC YAC520-EE2	
IC518	XZ545A00	IC YAC520-EE2	
IC519	XZ545A00	IC YAC520-EE2	
IC520	XY892A00	IC. CPU M30802SGP CPU	

\* New Parts

RX-V1200/RX-V1200RDS/HTR-5490/RX-V2200

**P.C.B. FUNCTION & P.C.B. OPERATION**

Schm Ref.	PART NO.	Description	Markets
IC521	XF291A00	IC	uPC4570G2
IC522	XJ604A00	IC	NJM78M05FA
IC523	XF291A00	IC	uPC4570G2
IC524	XF291A00	IC	uPC4570G2
IC525	XF291A00	IC	uPC4570G2
L501	VY656400	COIL. CHP	120uH
L502	VY656400	COIL. CHP	120uH
L503	VP133800	FER. BEAD	BL02RN1-R62T4
PJ501	V3855600	JACK. PIN	4P
PJ502	V3855600	JACK. PIN	4P
PJ503	V4198900	JACK. PIN	4P
PJ504	V4199200	JACK. PIN	6P
PN501	V3750200	PIN	L=70
Q501	VD303700	TR	2SC3326 A,B
Q502	VD303700	TR	2SC3326 A,B
Q503	VD303700	TR	2SC3326 A,B
Q504	VD303700	TR	2SC3326 A,B
Q505	VD303700	TR	2SC3326 A,B
Q506	VD303700	TR	2SC3326 A,B
Q507	VV556500	TR	2SA1037K Q, R, S
Q508	VV556500	TR	2SA1037K Q, R, S
Q509	VV655700	TR. DGT	DTC144EKA
Q510	VV655700	TR. DGT	DTC144EKA
Q511	VV556500	TR	2SA1037K Q, R, S
Q512	VV655700	TR. DGT	DTC144EKA
Q513	VD303700	TR	2SC3326 A,B
Q514	VD303700	TR	2SC3326 A,B
Q515	VD303700	TR	2SC3326 A,B
Q516	VD303700	TR	2SC3326 A,B
Q517	VD303700	TR	2SC3326 A,B
Q518	VD303700	TR	2SC3326 A,B
Q519	VD303700	TR	2SC3326 A,B
Q520	VV556500	TR	2SA1037K Q, R, S
Q521	VV556500	TR	2SA1037K Q, R, S
Q522	VV556500	TR	2SA1037K Q, R, S
Q523	VV556500	TR	2SA1037K Q, R, S
Q524	VV556500	TR	2SA1037K Q, R, S
Q525	VV556500	TR	2SA1037K Q, R, S
Q526	VP872700	TR	2SC4488 S, T
Q527	VV556500	TR	2SA1037K Q, R, S
Q528	VV556500	TR	2SA1037K Q, R, S
Q529	VV556500	TR	2SA1037K Q, R, S
Q530	VV556500	TR	2SA1037K Q, R, S
Q531	VV556500	TR	2SA1037K Q, R, S
Q532	VV556500	TR	2SA1037K Q, R, S
Q533	VD303700	TR	2SC3326 A,B
Q534	VD303700	TR	2SC3326 A,B
Q535	VP872600	TR	2SA1708 S, T
Q536	VV655700	TR. DGT	DTC144EKA
Q537	VD303700	TR	2SC3326 A,B
Q538	VD303700	TR	2SC3326 A,B
Q539	VD303700	TR	2SC3326 A,B
Q540	VD303700	TR	2SC3326 A,B
Q541	VD303700	TR	2SC3326 A,B
Q542	VD303700	TR	2SC3326 A,B
Q543	VD303700	TR	2SC3326 A,B
Q544	VD303700	TR	2SC3326 A,B
Q544	VD303700	TR	2SC3326 A,B
Q546	VD303700	TR	2SC3326 A,B
Q547	VD303700	TR	2SC3326 A,B
R561	HV755100	R. CAR. FP	100Ω 1/4W
R562	HV755100	R. CAR. FP	100Ω 1/4W
R636	HV753220	R. CAR. FP	2.2Ω 1/4W

\* New Parts

Schm Ref.	PART NO.	Description	Markets
R637	HV753220	R. CAR. FP	2.2Ω 1/4W
R664	HV753470	R. CAR. FP	4.7Ω 1/4W
R703	HV753220	R. CAR. FP	2.2Ω 1/4W
R704	HV753220	R. CAR. FP	2.2Ω 1/4W
R803	HV754100	R. CAR. FP	10Ω 1/4W
ST501	V4040500	SCR. TERM	M3
ST502	V4040500	SCR. TERM	M3
XL501	V4738900	RSNR. CE	12MHz
	V7950900	P. C. B.	OPERATION V1200
	V7951000	P. C. B.	OPERATION V1200
	V7951100	P. C. B.	OPERATION V1200
	V7951300	P. C. B.	OPERATION V2200
CB801	VM973500	CN. BS. PIN	17P
CB802	Vi878200	CN. BS. PIN	4P
CB901	Vi878500	CN. BS. PIN	7P
CB902	VQ044900	CN. BS. PIN	19P
CB941	Vi878100	CN. BS. PIN	3P
CB961	VK026200	CN. BS. PIN	3P
CB962	VK026600	CN. BS. PIN	7P
CB971	V7680700	CN. PHOT. SN	1P GP1FA512RZ
CB972	VQ047100	CN. BS. PIN	7P
CB973	Vi878200	CN. BS. PIN	4P
CB974	VB389900	CN. BS. PIN	3P
CB975	VB390000	CN. BS. PIN	4P
C801	UU137470	C. EL	47uF 16V
C802	UU137470	C. EL	47uF 16V
C803	UU137470	C. EL	47uF 16V
C804	UU137470	C. EL	47uF 16V
C805	UU165100	C. EL	0.1uF 50V
C806	UU165100	C. EL	0.1uF 50V
C807	UU165100	C. EL	0.1uF 50V
C808	UU165100	C. EL	0.1uF 50V
C809	UU166100	C. EL	1uF 50V
C810	UU166100	C. EL	1uF 50V
C811	UU166220	C. EL	2.2uF 50V
C812	UU166220	C. EL	2.2uF 50V
C813	VQ645600	C. MYLAR	100pF 50V
C814	VQ645600	C. MYLAR	100pF 50V
C815	UU137470	C. EL	47uF 16V
C816	UU137470	C. EL	47uF 16V
C817	UA655120	C. MYLAR	0.12uF 50V
C818	UA655120	C. MYLAR	0.12uF 50V
C819	UA654330	C. MYLAR	0.033uF 50V
C820	UA654330	C. MYLAR	0.033uF 50V
C821	UU147100	C. EL	10uF 25V
C822	UU147100	C. EL	10uF 25V
C823	UU147100	C. EL	10uF 25V
C824	UU147100	C. EL	10uF 25V
C825	UU147100	C. EL	10uF 25V
C826	UU147100	C. EL	10uF 25V
C827	UA652100	C. MYLAR	100pF 50V
C828	UA652100	C. MYLAR	100pF 50V
C829	UA652100	C. MYLAR	100pF 50V
C830	UA652100	C. MYLAR	100pF 50V
C831	UU147100	C. EL	10uF 25V
C832	UU147100	C. EL	10uF 25V
C833	VF466600	C. CE. TUBLR	10pF 50V
C834	VF466600	C. CE. TUBLR	10pF 50V
C835	UU139100	C. EL	1000uF 16V
C836	UU139100	C. EL	1000uF 16V

\* New Parts

RTKABG (V1200)  
(V2200)  
UCRTA  
UCRTA

RX-V1200/RX-V1200RDS/  
HTR-5490/RX-V2200

**P.C.B. OPERATION & P.C.B. DSP**

Schm Ref.	PART NO.	Description	Markets
C837	UA655120	C. MYLAR 0.12uF 50V	
C838	UA655120	C. MYLAR 0.12uF 50V	
C901	VJ599100	C. CE. TUBLR 0.1uF 50V	
C902	VJ599100	C. CE. TUBLR 0.1uF 50V	
C903	VJ599100	C. CE. TUBLR 0.1uF 50V	
C905	UM388100	C. EL 100uF 10V	
C906	VJ599100	C. CE. TUBLR 0.1uF 50V	
C907	VG277000	C. CE. TUBLR 33pF 50V	
C908	VJ599100	C. CE. TUBLR 0.1uF 50V	
C909	VJ599100	C. CE. TUBLR 0.1uF 50V	
C910	V6295600	C. EL 330uF 6.3V	
C911	VJ599100	C. CE. TUBLR 0.1uF 50V	
C912	VJ599100	C. CE. TUBLR 0.1uF 50V	
C961	VJ599100	C. CE. TUBLR 0.1uF 50V	
C971	VJ599100	C. CE. TUBLR 0.1uF 50V	
C972	UR837470	C. EL 47uF 16V	
C973	VF466900	C. CE. TUBLR 470pF 50V	
C974	VF466900	C. CE. TUBLR 470pF 50V	
C975	VJ599100	C. CE. TUBLR 0.1uF 50V	
C976	VJ599100	C. CE. TUBLR 0.1uF 50V	
C977	VF467000	C. CE. TUBLR 1000pF 50V	
C978	VF467000	C. CE. TUBLR 1000pF 50V	
C979	VF467300	C. CE. TUBLR 0.01uF 16V	
C980	VF467000	C. CE. TUBLR 1000pF 50V	
C981	VJ599100	C. CE. TUBLR 0.1uF 50V	
C983	VJ599100	C. CE. TUBLR 0.1uF 50V	
C984	VJ599100	C. CE. TUBLR 0.1uF 50V	
C985	VJ599100	C. CE. TUBLR 0.1uF 50V	
D801	VG439100	DIODE. ZENR MTZJ9.1A 9.1V	
D802	VG439100	DIODE. ZENR MTZJ9.1A 9.1V	
D803	VU264100	DIODE 1SR139-400	
D804	VU264100	DIODE 1SR139-400	
D901	VM974700	DIODE. ZENR HZS7B2TD 7.0V	
D902	V2598200	LED SIR-505ST	UCA (V1200)
D902	V2598200	LED SIR-505ST	UCRTA (V2200)
G961	V8880000	TERM. GND M3.5 RJP9899	
IC801	iG001270	IC TC4066BP	
IC802	XM356A00	IC NJM2068LD	
IC803	XM356A00	IC NJM2068LD	
IC804	XP844A00	IC NJM4556AL	
IC901	XV160A00	IC LC75712E FLD	
JK971	V2589500	CN 1P	
JK972	V4164400	JACK. PHONE YKB21-5209	
L971	V2726500	COIL 68uH	
PJ971	V6222800	JACK. PIN 3P	
PN901	V3750200	PIN L=70	
Q801	VG721700	TR. DGT DTA144ES	
Q802	VG722000	TR. DGT DTC144ES	
Q803	VK432900	TR 2SD1915F S,T	
Q804	VK432900	TR 2SD1915F S,T	
Q901	VV900500	TR 2SD1991A Q,R,S	
Q902	VV900500	TR 2SD1991A Q,R,S	
Q905	VV900500	TR 2SD1991A Q,R,S	
Q906	VV900500	TR 2SD1991A Q,R,S	
Q907	VV900500	TR 2SD1991A Q,R,S	
Q908	VV900500	TR 2SD1991A Q,R,S	
Q909	VV900500	TR 2SD1991A Q,R,S	
Q910	VV900500	TR 2SD1991A Q,R,S	
Q971	iC174020	TR 2SC1740S R,S	
Q972	iA093320	TR 2SA933S Q,R	
R803	VP940200	R. MTL. OXD 47Ω 1W	
R804	VP940200	R. MTL. OXD 47Ω 1W	
R841	VP940600	R. MTL. OXD 220Ω 1W	

\* New Parts

Schm Ref.	PART NO.	Description	Markets
R842	VP940600	R. MTL. OXD 220Ω 1W	
R847	HB026220	R. MTL. FLM 2.2KΩ 1/4W	(V2200)
R848	HB026220	R. MTL. FLM 2.2KΩ 1/4W	(V2200)
R849	HB026220	R. MTL. FLM 2.2KΩ 1/4W	(V2200)
R850	HB026220	R. MTL. FLM 2.2KΩ 1/4W	(V2200)
R851	HB027120	R. MTL. FLM 12KΩ 1/4W	(V2200)
R852	HB027120	R. MTL. FLM 12KΩ 1/4W	(V2200)
R853	HB027120	R. MTL. FLM 12KΩ 1/4W	(V2200)
R854	HB027240	R. MTL. FLM 24KΩ 1/4W	(V2200)
R855	HB027240	R. MTL. FLM 24KΩ 1/4W	(V2200)
R856	HB027240	R. MTL. FLM 24KΩ 1/4W	(V2200)
R857	HB027240	R. MTL. FLM 24KΩ 1/4W	(V2200)
R858	HB027240	R. MTL. FLM 24KΩ 1/4W	(V2200)
ST971	V4040500	SCR. TERM M3	
ST972	V4040500	SCR. TERM M3	
ST973	V4040500	SCR. TERM M3	
SW801	V6154000	SW. RT. ENC SDB161PH20FS-1-4	(V2200)
SW901	VG392900	SW. TACT SKHVAA	
SW902	VG392900	SW. TACT SKHVAA	
SW903	V6322700	SW. RT. ENC REB161(9X7)PVB	
SW904	VG392900	SW. TACT SKHVAA	
SW905	VG392900	SW. TACT SKHVAA	
SW941	VG392900	SW. TACT SKHVAA	BG (V1200)
SW942	VG392900	SW. TACT SKHVAA	BG (V1200)
SW943	VG392900	SW. TACT SKHVAA	BG (V1200)
SW944	VG392900	SW. TACT SKHVAA	BG (V1200)
SW945	VG392900	SW. TACT SKHVAA	
SW946	VG392900	SW. TACT SKHVAA	
SW947	VG392900	SW. TACT SKHVAA	
SW948	VG392900	SW. TACT SKHVAA	
SW949	VG392900	SW. TACT SKHVAA	
SW950	VG392900	SW. TACT SKHVAA	
SW951	VG392900	SW. TACT SKHVAA	
SW952	VG392900	SW. TACT SKHVAA	
SW953	VG392900	SW. TACT SKHVAA	
SW954	VG392900	SW. TACT SKHVAA	
SW961	VG392900	SW. TACT SKHVAA	
SW962	VG392900	SW. TACT SKHVAA	
SW963	VG392900	SW. TACT SKHVAA	
SW964	VG392900	SW. TACT SKHVAA	
SW965	VG392900	SW. TACT SKHVAA	
U901	VU591000	L. DTCT GP1U271X	
V901	V7683200	FL. DSPLY 16-BT-91GK	
VR801	VP741800	VR B20KΩ	
VR802	VP741900	VR G25KΩ	
	V6007100	SPACER 4.6/10/32	
	V6007000	SHEET	
	V7946700	P. C. B.	DSP
CB503	VQ046000	CN. BS. PIN 31P	
CB504	VQ047000	CN. BS. PIN 6P	
C501	US135100	C. CE. CHP 0.1uF 16V	
C502	US135100	C. CE. CHP 0.1uF 16V	
C503	US135100	C. CE. CHP 0.1uF 16V	
C504	US135100	C. CE. CHP 0.1uF 16V	
C505	US135100	C. CE. CHP 0.1uF 16V	
C506	US135100	C. CE. CHP 0.1uF 16V	
C507	US061220	C. CE. M. CHP 22pF 50V	
C508	US061220	C. CE. M. CHP 22pF 50V	
C509	UR847220	C. EL 22uF 25V	
C510	UR847220	C. EL 22uF 25V	

\* New Parts

RX-V1200/RX-V1200RDS/HTR-5490/RX-V2200

## P.C.B. DSP

Schm Ref.	PART NO.	Description	Markets
C511	US135100	C. CE. CHP	0. 1uF 16V
C512	US135100	C. CE. CHP	0. 1uF 16V
C513	UR819100	C. EL	1000uF 6. 3V
C514	US061100	C. CE. M. CHP	10pF 50V
C515	US061100	C. CE. M. CHP	10pF 50V
C516	US135100	C. CE. CHP	0. 1uF 16V
C517	US061470	C. CE. M. CHP	47pF 50V
C518	US061470	C. CE. M. CHP	47pF 50V
C519	US135100	C. CE. CHP	0. 1uF 16V
C520	US063100	C. CE. M. CHP	1000pF 50V
C521	US063100	C. CE. M. CHP	1000pF 50V
C522	UR819100	C. EL	1000uF 6. 3V
C523	UR819100	C. EL	1000uF 6. 3V
C524	US135100	C. CE. CHP	0. 1uF 16V
C525	US135100	C. CE. CHP	0. 1uF 16V
C526	US135100	C. CE. CHP	0. 1uF 16V
C527	US135100	C. CE. CHP	0. 1uF 16V
C528	US135100	C. CE. CHP	0. 1uF 16V
C529	US135100	C. CE. CHP	0. 1uF 16V
C530	US135100	C. CE. CHP	0. 1uF 16V
C531	UR819100	C. EL	1000uF 6. 3V
C532	US135100	C. CE. CHP	0. 1uF 16V
C533	UR819100	C. EL	1000uF 6. 3V
C534	US135100	C. CE. CHP	0. 1uF 16V
C535	US135100	C. CE. CHP	0. 1uF 16V
C536	US135100	C. CE. CHP	0. 1uF 16V
C537	US135100	C. CE. CHP	0. 1uF 16V
C538	UR818100	C. EL	100uF 6. 3V
C539	US135100	C. CE. CHP	0. 1uF 16V
C540	US135100	C. CE. CHP	0. 1uF 16V
C543	US135100	C. CE. CHP	0. 1uF 16V
C544	UU147100	C. EL	10uF 25V
C545	UU147100	C. EL	10uF 25V
C546	UU147100	C. EL	10uF 25V
C547	UA652150	C. MYLAR	150pF 50V
C548	UA652150	C. MYLAR	150pF 50V
C549	UA652680	C. MYLAR	680pF 50V
C550	UA652470	C. MYLAR	470pF 50V
C551	UR818470	C. EL	470uF 6. 3V
C552	UA652100	C. MYLAR	100pF 50V
C553	UA652100	C. MYLAR	100pF 50V
C554	UA652100	C. MYLAR	100pF 50V
C555	UA652100	C. MYLAR	100pF 50V
C556	UA653150	C. MYLAR	1500pF 50V
C557	UR818100	C. EL	100uF 6. 3V
C558	UU137220	C. EL	22uF 16V
C559	UU137220	C. EL	22uF 16V
C560	UU128100	C. EL	100uF 10V
C561	UU166220	C. EL	2. 2uF 50V
C562	UU118100	C. EL	100uF 6. 3V
C563	UU118100	C. EL	100uF 6. 3V
C564	US061100	C. CE. M. CHP	10pF 50V
C565	US063100	C. CE. M. CHP	1000pF 50V
C566	US061330	C. CE. M. CHP	33pF 50V
C567	US044220	C. CE. M. CHP	0. 022uF 25V
C568	UR818100	C. EL	100uF 6. 3V
C569	UR818100	C. EL	100uF 6. 3V
C571	US062470	C. CE. M. CHP	470pF 50V
C572	US063470	C. CE. CHP	4700pF 50V
C573	US063470	C. CE. CHP	4700pF 50V
C574	UR818470	C. EL	470uF 6. 3V
C575	US061470	C. CE. M. CHP	47pF 50V
C576	US135100	C. CE. CHP	0. 1uF 16V

\* New Parts

Schm Ref.	PART NO.	Description	Markets
C577	US135100	C. CE. CHP	0. 1uF 16V
C578	US135100	C. CE. CHP	0. 1uF 16V
C580	US061470	C. CE. M. CHP	47pF 50V
C581	US061470	C. CE. M. CHP	47pF 50V
C582	US061470	C. CE. M. CHP	47pF 50V
C584	US135100	C. CE. CHP	0. 1uF 16V
C585	US061470	C. CE. M. CHP	47pF 50V
C586	US061470	C. CE. M. CHP	47pF 50V
C587	US135100	C. CE. CHP	0. 1uF 16V
C588	US135100	C. CE. CHP	0. 1uF 16V
C590	US135100	C. CE. CHP	0. 1uF 16V
C591	UR818100	C. EL	100uF 6. 3V
C592	US135100	C. CE. CHP	0. 1uF 16V
C593	US135100	C. CE. CHP	0. 1uF 16V
C594	UR819100	C. EL	1000uF 6. 3V
C595	US064100	C. CE. M. CHP	0. 01uF 50V
C596	US135100	C. CE. CHP	0. 1uF 16V
C597	US135100	C. CE. CHP	0. 1uF 16V
C598	US061470	C. CE. M. CHP	47pF 50V
C599	US061470	C. CE. M. CHP	47pF 50V
C600	US061470	C. CE. M. CHP	47pF 50V
C601	US061470	C. CE. M. CHP	47pF 50V
C602	US061470	C. CE. M. CHP	47pF 50V
C603	US061470	C. CE. M. CHP	47pF 50V
C604	US061470	C. CE. M. CHP	47pF 50V
C605	US061470	C. CE. M. CHP	47pF 50V
C606	US061470	C. CE. M. CHP	47pF 50V
C607	US135100	C. CE. CHP	0. 1uF 16V
C608	US135100	C. CE. CHP	0. 1uF 16V
C609	US135100	C. CE. CHP	0. 1uF 16V
C610	UU137470	C. EL	47uF 16V
C611	UU137470	C. EL	47uF 16V
C612	US135100	C. CE. CHP	0. 1uF 16V
C613	US135100	C. CE. CHP	0. 1uF 16V
C614	US135100	C. CE. CHP	0. 1uF 16V
C615	UU137470	C. EL	47uF 16V
C616	US135100	C. CE. CHP	0. 1uF 16V
C617	UU137470	C. EL	47uF 16V
C618	US135100	C. CE. CHP	0. 1uF 16V
C619	UU137470	C. EL	47uF 16V
C620	US135100	C. CE. CHP	0. 1uF 16V
C621	UU137470	C. EL	47uF 16V
C622	US135100	C. CE. CHP	0. 1uF 16V
C623	UU137470	C. EL	47uF 16V
C624	US135100	C. CE. CHP	0. 1uF 16V
C625	UU137470	C. EL	47uF 16V
C626	US135100	C. CE. CHP	0. 1uF 16V
C627	UU147100	C. EL	10uF 25V
C628	UU147100	C. EL	10uF 25V
C629	UU147100	C. EL	10uF 25V
C630	UU147100	C. EL	10uF 25V
C631	UU147100	C. EL	10uF 25V
C632	UU147100	C. EL	10uF 25V
C633	UU147100	C. EL	10uF 25V
C634	UU147100	C. EL	10uF 25V
C635	UU147100	C. EL	10uF 25V
C636	UU147100	C. EL	10uF 25V
C637	UA653150	C. MYLAR	1500pF 50V
C638	US135100	C. CE. CHP	0. 1uF 16V
C639	US135100	C. CE. CHP	0. 1uF 16V
C640	US135100	C. CE. CHP	0. 1uF 16V
C641	US135100	C. CE. CHP	0. 1uF 16V
C642	US135100	C. CE. CHP	0. 1uF 16V

\* New Parts

P.C.B. DSP

Schm Ref.	PART NO.	Description	Markets
C643	US135100	C. CE. CHP	0. 1uF 16V
C644	UA652680	C. MYLAR	680pF 50V
C645	UA652680	C. MYLAR	680pF 50V
C646	UA652150	C. MYLAR	150pF 50V
C647	UA652150	C. MYLAR	150pF 50V
C648	UU147100	C. EL	10uF 25V
C649	UU147100	C. EL	10uF 25V
C650	UU147100	C. EL	10uF 25V
C651	UU147100	C. EL	10uF 25V
C652	UU147100	C. EL	10uF 25V
C653	UU147100	C. EL	10uF 25V
C654	UA652150	C. MYLAR	150pF 50V
C655	UA652150	C. MYLAR	150pF 50V
C656	US135100	C. CE. CHP	0. 1uF 16V
C657	US135100	C. CE. CHP	0. 1uF 16V
C658	UU147100	C. EL	10uF 25V
C659	UU147100	C. EL	10uF 25V
C660	UA652470	C. MYLAR	470pF 50V
C661	UA652470	C. MYLAR	470pF 50V
C662	UA652470	C. MYLAR	470pF 50V
C663	UA652470	C. MYLAR	470pF 50V
C664	UA652470	C. MYLAR	470pF 50V
C665	UU147100	C. EL	10uF 25V
C666	UU147100	C. EL	10uF 25V
C667	UU147100	C. EL	10uF 25V
C668	UU147100	C. EL	10uF 25V
C669	UU147100	C. EL	10uF 25V
C670	UU147100	C. EL	10uF 25V
C671	UU147100	C. EL	10uF 25V
C672	US135100	C. CE. CHP	0. 1uF 16V
C673	UU137470	C. EL	47uF 16V
C674	UU137470	C. EL	47uF 16V
C675	UU137470	C. EL	47uF 16V
C676	UU137470	C. EL	47uF 16V
C677	US135100	C. CE. CHP	0. 1uF 16V
C678	US135100	C. CE. CHP	0. 1uF 16V
C679	US135100	C. CE. CHP	0. 1uF 16V
C680	US135100	C. CE. CHP	0. 1uF 16V
C681	US062220	C. CE. CHP	220pF 50V
C682	US062220	C. CE. CHP	220pF 50V
C683	UR866220	C. EL	2. 2uF 50V
C684	US062470	C. CE. M. CHP	470pF 50V
C686	UR817470	C. EL	47uF 6. 3V
* C687	US061300	C. CE. M. CHP	30pF 50V
C688	UR818100	C. EL	100uF 6. 3V
C689	US135100	C. CE. CHP	0. 1uF 16V
C691	US135100	C. CE. CHP	0. 1uF 16V
C692	UR818100	C. EL	100uF 6. 3V
C695	UR818100	C. EL	100uF 6. 3V
C696	UR818100	C. EL	100uF 6. 3V
C697	US135100	C. CE. CHP	0. 1uF 16V
C698	US135100	C. CE. CHP	0. 1uF 16V
C699	UR818100	C. EL	100uF 6. 3V
C700	US135100	C. CE. CHP	0. 1uF 16V
C701	US064100	C. CE. M. CHP	0. 01uF 50V
C702	US135100	C. CE. CHP	0. 1uF 16V
C703	UR818100	C. EL	100uF 6. 3V
C706	US061470	C. CE. M. CHP	47pF 50V
C707	US061470	C. CE. M. CHP	47pF 50V
C708	US135100	C. CE. CHP	0. 1uF 16V
C709	US135100	C. CE. CHP	0. 1uF 16V
C710	UR818100	C. EL	100uF 6. 3V
C711	UR818100	C. EL	100uF 6. 3V

\* New Parts

Schm Ref.	PART NO.	Description	Markets
C712	UR818100	C. EL	100uF 6. 3V
C713	US061470	C. CE. M. CHP	47pF 50V
C716	US135100	C. CE. CHP	0. 1uF 16V
C717	US135100	C. CE. CHP	0. 1uF 16V
C718	US135100	C. CE. CHP	0. 1uF 16V
C719	US135100	C. CE. CHP	0. 1uF 16V
C720	UR818100	C. EL	100uF 6. 3V
C722	UR818100	C. EL	100uF 6. 3V
C723	US135100	C. CE. CHP	0. 1uF 16V
C724	UR818100	C. EL	100uF 6. 3V
C725	US135100	C. CE. CHP	0. 1uF 16V
C726	US135100	C. CE. CHP	0. 1uF 16V
C727	US135100	C. CE. CHP	0. 1uF 16V
C728	US135100	C. CE. CHP	0. 1uF 16V
C729	US135100	C. CE. CHP	0. 1uF 16V
C730	US135100	C. CE. CHP	0. 1uF 16V
C731	US135100	C. CE. CHP	0. 1uF 16V
C732	UR819100	C. EL	1000uF 6. 3V
C733	US135100	C. CE. CHP	0. 1uF 16V
C734	US062100	C. CE. M. CHP	100pF 50V
C735	US061470	C. CE. M. CHP	47pF 50V
D501	VT332900	DIODE	1SS355
D502	VT332900	DIODE	1SS355
D503	VT332900	DIODE	1SS355
D504	VV220700	DIODE. SHOT	RB501V-40
D505	VV220700	DIODE. SHOT	RB501V-40
D506	VT332900	DIODE	1SS355
D507	VT332900	DIODE	1SS355
D508	VV220700	DIODE. SHOT	RB501V-40
D509	VV220700	DIODE. SHOT	RB501V-40
D510	VV220700	DIODE. SHOT	RB501V-40
D511	VV220700	DIODE. SHOT	RB501V-40
D512	VV220700	DIODE. SHOT	RB501V-40
D513	VV220700	DIODE. SHOT	RB501V-40
D514	VV220700	DIODE. SHOT	RB501V-40
D515	VV220700	DIODE. SHOT	RB501V-40
D516	VT332900	DIODE	1SS355
D517	VT332900	DIODE	1SS355
D518	VT332900	DIODE	1SS355
D519	VT332900	DIODE	1SS355
D520	VT332900	DIODE	1SS355
D521	VT332900	DIODE	1SS355
D522	VT332900	DIODE	1SS355
D523	VT332900	DIODE	1SS355
D524	VT332900	DIODE	1SS355
D525	VT332900	DIODE	1SS355
D526	VT332900	DIODE	1SS355
D527	VT332900	DIODE	1SS355
D528	VT332900	DIODE	1SS355
D529	VT332900	DIODE	1SS355
D530	VT332900	DIODE	1SS355
D531	VT332900	DIODE	1SS355
D532	VT332900	DIODE	1SS355
D533	VT332900	DIODE	1SS355
D534	VT332900	DIODE	1SS355
D537	VT332900	DIODE	1SS355
D538	VT332900	DIODE	1SS355
IC501	XD660A00	IC	TC74HCU04AF-TP1
IC502	XD660A00	IC	TC74HCU04AF-TP1
* IC503	XY120A00	IC	TC74HCT00AF(EL) NA
IC508	XW029A00	IC	AK4393-VF-E2
IC509	XF291A00	IC	uPC4570G2
* IC510	XO237A00	IC	AK4527BVQ

\* New Parts

RX-V1200/RX-V1200RDS/  
HTR-5490/RX-V2200

P.C.B. DSP & P.C.B. VIDEO

RX-V1200/RX-V1200RDS/  
HTR-5490/RX-V2200

Schm Ref.	PART NO.	Description	Markets
* IC512	XZ012A00	IC TC74HCT08AF(EL)	
* IC513	XR038A00	IC NJM2904M OP AMP	
* IC514	X0238A00	IC YSS938-F	
IC515	XV077A00	IC MSM514260C-60JS	
IC516	XU965A00	IC uPC29M33T-E1 3.3V	
IC517	XZ003A00	IC PQ025EZ5MZP 2.5V	
IC518	XF291A00	IC uPC4570G2	
IC519	XF291A00	IC uPC4570G2	
IC520	XF291A00	IC uPC4570G2	
IC521	XF291A00	IC uPC4570G2	
IC522	XF291A00	IC uPC4570G2	
IC523	XF291A00	IC uPC4570G2	
IC524	XW029A00	IC AK4393-VF-E2	
* IC525	X0594A00	IC CS493292-CLR	
* IC526	X0318C00	IC XC9572XL-10TQ100C	
* IC527	XW433A00	IC CY62256LL-70SNCT	
* IC528	X0604A00	IC MBM29F400BC-70PFTN	
L501	V2726500	COIL 68uH	
L502	V2726500	COIL 68uH	
L503	V2726500	COIL 68uH	
L504	V2726500	COIL 68uH	
PJ501	V5715300	JACK.PIN 2P OR/OR	
Q501	VV655300	TR.DGT DTA144EKA	
Q502	VV655300	TR.DGT DTA144EKA	
Q503	VV655300	TR.DGT DTA144EKA	
Q504	VV655300	TR.DGT DTA144EKA	
Q505	VV655300	TR.DGT DTA144EKA	
Q506	VV655300	TR.DGT DTA144EKA	
Q507	VV655300	TR.DGT DTA144EKA	
Q508	VD303700	TR 2SC3326 A,B	
Q509	VV655300	TR.DGT DTA144EKA	
Q510	VD303700	TR 2SC3326 A,B	
Q511	VD303700	TR 2SC3326 A,B	
Q512	VD303700	TR 2SC3326 A,B	
Q513	VD303700	TR 2SC3326 A,B	
Q514	VD303700	TR 2SC3326 A,B	
Q515	VD303700	TR 2SC3326 A,B	
Q516	VD303700	TR 2SC3326 A,B	
Q517	VD303700	TR 2SC3326 A,B	
R533	VU224000	R.MTL.FLM 0.22Ω 1W J	
R534	HV753220	R.CAR.FP 2.2Ω 1/4W	
R535	VU224000	R.MTL.FLM 0.22Ω 1W J	
R553	HV753220	R.CAR.FP 2.2Ω 1/4W	
R555	VU224000	R.MTL.FLM 0.22Ω 1W J	
R591	HV753100	R.CAR.FP 1Ω 1/4W	
R592	HV753100	R.CAR.FP 1Ω 1/4W	
R619	HV753220	R.CAR.FP 2.2Ω 1/4W	
R626	HV753220	R.CAR.FP 2.2Ω 1/4W	
R661	HV753220	R.CAR.FP 2.2Ω 1/4W	
R662	HV753220	R.CAR.FP 2.2Ω 1/4W	
R666	HV753220	R.CAR.FP 2.2Ω 1/4W	
R671	HV753220	R.CAR.FP 2.2Ω 1/4W	
TP1	VL448600	JUMPER.TST	
TP2	VL448600	JUMPER.TST	
TP3	VL448600	JUMPER.TST	
* U501	V7680700	CN.PHOT.SN 1P GP1FA512RZ	
* U502	V7680700	CN.PHOT.SN 1P GP1FA512RZ	
* U503	V7680700	CN.PHOT.SN 1P GP1FA512RZ	
* U504	V7680700	CN.PHOT.SN 1P GP1FA512RZ	
* U505	V7680800	CN.PHOT.SN 1P GP1FA512TZ	
* U506	V7680800	CN.PHOT.SN 1P GP1FA512TZ	
XL503	V6931900	RESONATOR 24.576MHz DS0751SV	

\* New Parts

Schm Ref.	PART NO.	Description	Markets
* V7947100	P.C.B.	VIDEO V1200	UC
* V7947200	P.C.B.	VIDEO V1200	RTK
* V7947300	P.C.B.	VIDEO V1200	A
* V7947400	P.C.B.	VIDEO V1200RDS	BG
* V7947500	P.C.B.	VIDEO 5490	UC
* V7947600	P.C.B.	VIDEO 5490	T
* V7947700	P.C.B.	VIDEO 5490	A
* V7947900	P.C.B.	VIDEO V2200	UC
* V7948000	P.C.B.	VIDEO V2200	RT
* V7948100	P.C.B.	VIDEO V2200	A
* CB551	V7827700	SOCKET 10P TE TUC SERIES	
* CB552	V7827800	SOCKET 11P TE TUC SERIES	
* CB581	V7826500	CN 15P TE TUC SERIES	
* CB582	VM929900	CN.BS.PIN 15P	
* CB583	V7826100	CN 11P TE TUC SERIES	
* CB584	VQ044500	CN.BS.PIN 11P	
* CB585	V7826200	CN 12P TE TUC SERIES	
* CB586	V7826200	CN 12P TE TUC SERIES	
* CB587	V7826500	CN 15P TE TUC SERIES	
* CB588	V7826500	CN 15P TE TUC SERIES	
* CB589	V7825400	CN 4P TE TUC SERIES	
* CB590	V7825500	CN 5P TE TUC SERIES	
* CB591	V7826000	CN 10P TE TUC SERIES	
* CB592	V7827700	SOCKET 10P TE TUC SERIES	
* CB593	V7826100	CN 11P TE TUC SERIES	
* CB594	V7827800	SOCKET 11P TE TUC SERIES	
* CB601	V7828200	SOCKET 15P TE TUC SERIES	
* CB602	V7827900	SOCKET 12P TE TUC SERIES	
* CB603	V7827100	SOCKET 4P TE TUC SERIES	
* CB604	VQ044300	CN.BS.PIN 7P	
* CB605	V7827100	SOCKET 4P TE TUC SERIES	
* CB701	V7828200	SOCKET 15P TE TUC SERIES	
* CB751	V7827200	SOCKET 5P TE TUC SERIES	
* CB755	V7827100	SOCKET 4P TE TUC SERIES	
* CB861	V7825400	CN 4P TE TUC SERIES	
* CB862	V7825400	CN 4P TE TUC SERIES	
C551	US135100	C.CE.CHP 0.1uF 16V	
C552	US135100	C.CE.CHP 0.1uF 16V	
C553	UA652470	C.MYLAR 470pF 50V	
C554	UA652470	C.MYLAR 470pF 50V	
C555	UA652470	C.MYLAR 470pF 50V	
C556	UA652470	C.MYLAR 470pF 50V	
C557	UA652470	C.MYLAR 470pF 50V	
C558	UA652470	C.MYLAR 470pF 50V	
C559	UA652470	C.MYLAR 470pF 50V	
C560	UA652470	C.MYLAR 470pF 50V	
C561	UA652470	C.MYLAR 470pF 50V	
C562	UA652470	C.MYLAR 470pF 50V	
C563	UA652470	C.MYLAR 470pF 50V	
C564	UA652470	C.MYLAR 470pF 50V	
C565	UA652470	C.MYLAR 470pF 50V	
C566	UA652470	C.MYLAR 470pF 50V	
C567	UA652470	C.MYLAR 470pF 50V	
C568	UA652470	C.MYLAR 470pF 50V	
C581	US063100	C.CE.M.CHP 1000pF 50V	
C582	US063100	C.CE.M.CHP 1000pF 50V	
C583	US064100	C.CE.M.CHP 0.01uF 50V	
C584	US063100	C.CE.M.CHP 1000pF 50V	
C585	US063100	C.CE.M.CHP 1000pF 50V	
C586	US062100	C.CE.M.CHP 100pF 50V	
C587	UR866100	C.EL 1uF 50V	
C588	UR837470	C.EL 47uF 16V	
C591	US062330	C.CE.M.CHP 330pF 50V	BG (V1200)

\* New Parts

**P.C.B. VIDEO**

Schm Ref.	PART NO.	Description	Markets
C592	US062330	C. CE. M. CHP 330pF 50V	BG (V1200)
C593	US062560	C. CE. CHP 560pF 50V	BG (V1200)
C594	UR837470	C. EL 47uF 16V	BG (V1200)
C595	UR837470	C. EL 47uF 16V	BG (V1200)
C596	US061270	C. CE. M. CHP 27pF 50V	BG (V1200)
C597	US061270	C. CE. M. CHP 27pF 50V	BG (V1200)
C598	US135100	C. CE. CHP 0. 1uF 16V	BG (V1200)
C599	UR837470	C. EL 47uF 16V	BG (V1200)
C601	US062100	C. CE. M. CHP 100pF 50V	
C602	US062100	C. CE. M. CHP 100pF 50V	
C603	US062100	C. CE. M. CHP 100pF 50V	
C604	US062100	C. CE. M. CHP 100pF 50V	
C605	US062100	C. CE. M. CHP 100pF 50V	
C606	US062100	C. CE. M. CHP 100pF 50V	
C607	US135100	C. CE. CHP 0. 1uF 16V	
C608	US135100	C. CE. CHP 0. 1uF 16V	
C609	US135100	C. CE. CHP 0. 1uF 16V	
C610	UR829100	C. EL 1000uF 10V	
C611	UR837470	C. EL 47uF 16V	
C612	UM397470	C. EL 47uF 16V	
C613	UR837100	C. EL 10uF 16V	
C614	US135100	C. CE. CHP 0. 1uF 16V	(V2200)
C616	US135100	C. CE. CHP 0. 1uF 16V	(V2200)
C617	UM397470	C. EL 47uF 16V	
C618	UM397470	C. EL 47uF 16V	
C619	US062820	C. CE. CHP 820pF 50V	ABG
C619	US063150	C. CE. M. CHP 1500pF 50V	UCR TK
C620	US062270	C. CE. M. CHP 270pF 50V	ABG
C620	US062390	C. CE. CHP 390P 50V	UCR TK
C621	UM397470	C. EL 47uF 16V	
C622	UR837470	C. EL 47uF 16V	
C623	UR818220	C. EL 220uF 6. 3V	
C624	UR818220	C. EL 220uF 6. 3V	
C625	UM397100	C. EL 10uF 16V	
C626	UR837470	C. EL 47uF 16V	
C627	UR837100	C. EL 10uF 16V	
C628	US135100	C. CE. CHP 0. 1uF 16V	
C629	US135100	C. CE. CHP 0. 1uF 16V	
C630	US060800	C. CE. CHP 8pF 50V	
C631	UR837470	C. EL 47uF 16V	
C632	UM397470	C. EL 47uF 16V	
C633	US061330	C. CE. M. CHP 33pF 50V	
C634	US064100	C. CE. M. CHP 0. 01uF 50V	
C635	UR837470	C. EL 47uF 16V	
C636	UR866470	C. EL 4. 7uF 50V	
C637	UR818330	C. EL 330uF 6. 3V	
C638	US135100	C. CE. CHP 0. 1uF 16V	
C639	US063120	C. CE. M. CHP 1200pF 50V	
C640	US062470	C. CE. M. CHP 470pF 50V	
C641	UR866100	C. EL 1uF 50V	
C642	UR866100	C. EL 1uF 50V	
C643	US060700	C. CE. CHP 7pF 50V	
C644	US061240	C. CE. CHP 24pF 50V	
C645	US061240	C. CE. CHP 24pF 50V	
C646	US062220	C. CE. CHP 220pF 50V	
C647	US062120	C. CE. CHP 120pF 50V	
C648	UR837470	C. EL 47uF 16V	
C650	US135100	C. CE. CHP 0. 1uF 16V	
C651	US135100	C. CE. CHP 0. 1uF 16V	
C652	US135100	C. CE. CHP 0. 1uF 16V	
C653	US062470	C. CE. CHP 470pF 50V	
C701	US062100	C. CE. M. CHP 100pF 50V	
C702	US062100	C. CE. M. CHP 100pF 50V	

\* New Parts

Schm Ref.	PART NO.	Description	Markets
C703	US062100	C. CE. M. CHP 100pF 50V	(V2200)
C704	US062100	C. CE. M. CHP 100pF 50V	
C705	UR837470	C. EL 47uF 16V	
C706	UR829100	C. EL 1000uF 10V	
C707	UR837470	C. EL 47uF 16V	
C708	US135100	C. CE. CHP 0. 1uF 16V	
C709	US135100	C. CE. CHP 0. 1uF 16V	
C710	UR837470	C. EL 47uF 16V	
C711	UR837470	C. EL 47uF 16V	(V2200)
C712	UR837470	C. EL 47uF 16V	
C713	UR837470	C. EL 47uF 16V	
C714	UR837470	C. EL 47uF 16V	
C715	US135100	C. CE. CHP 0. 1uF 16V	
C751	US061240	C. CE. CHP 24pF 50V	
C752	US061240	C. CE. CHP 24pF 50V	
C753	US061240	C. CE. CHP 24pF 50V	
C754	US135100	C. CE. CHP 0. 1uF 16V	
C755	US135100	C. CE. CHP 0. 1uF 16V	
C756	UR837470	C. EL 47uF 16V	
C757	UR837470	C. EL 47uF 16V	
C758	US064100	C. CE. M. CHP 0. 01uF 50V	(V2200)
C759	US064100	C. CE. M. CHP 0. 01uF 50V	(V2200)
C760	US064100	C. CE. M. CHP 0. 01uF 50V	(V2200)
C761	US064100	C. CE. M. CHP 0. 01uF 50V	(V2200)
C762	US064100	C. CE. M. CHP 0. 01uF 50V	(V2200)
C763	US064100	C. CE. M. CHP 0. 01uF 50V	(V2200)
C764	US064100	C. CE. M. CHP 0. 01uF 50V	(V2200)
C765	US064100	C. CE. M. CHP 0. 01uF 50V	(V2200)
D581	VU172000	DIODE. ZENR UDZ5. 6BTE-17 5. 6V	
D601	VT332900	DIODE 1SS355	
D602	VT332900	DIODE 1SS355	
D603	VT332900	DIODE 1SS355	
D604	VT332900	DIODE 1SS355	
D605	VT332900	DIODE 1SS355	
D606	VT332900	DIODE 1SS355	
D607	VT332900	DIODE 1SS355	
D608	VT332900	DIODE 1SS355	
D609	VT332900	DIODE 1SS355	
D610	VT332900	DIODE 1SS355	
G581	V8880000	TERM. GND M3. 5 RJP9899	
IC581	XY534A00	IC LC72722	BG (V1200)
IC601	XW939A00	IC TK15420M VIDEO AMP	
IC602	XL493A00	IC TC74HC4051AP	
IC603	XL493A00	IC TC74HC4051AP	
IC604	XZ830A00	IC MM74HC4051N MULTI	(V2200)
IC605	XZ830A00	IC MM74HC4051N MULTI	(V2200)
IC606	X2093A00	IC MM74HC4053N MULTI	(V2200)
IC607	iR405300	IC TC74HC4053AP	
IC608	XD598A00	IC TC74HC04AFEL INV	
IC609	XY443A00	IC LA7109 6CH	
IC610	XZ060A00	IC LC74781-9798	
IC611	XW416A00	IC BU2092 SER/PAR	
IC701	XW911A00	IC LA7108M VIDEO AMP	
IC702	XY549A00	IC TC74HC4051AFEL	
IC703	XY550A00	IC MM74HC4051SJX	(V2200)
IC704	XY877A00	IC MM74HC4053SJX	(V2200)
IC751	XY877A00	IC MM74HC4053SJX	
IC752	X0428A00	IC OPA2652U OP AMP	
IC753	X0428A00	IC OPA2652U OP AMP	
JK601	VP113600	CN. DIN 2P	
JK602	VP113600	CN. DIN 2P	
JK603	VP113600	CN. DIN 2P	
JK604	VU245200	CN. DIN 1P	

\* New Parts

RX-V1200/RX-V1200RDS/HTR-5490/RX-V2200

P.C.B. VIDEO & P.C.B. MAIN

Schm Ref.	PART NO.	Description	Markets
JK605	VQ960400	CN. DIN	1P
L581	VK267500	COIL	220uH
L602	V3233700	COIL	1.5uH
L603	V6236000	COIL	4.7uH LAV35VB4R7K
L605	V2726100	COIL	33uH
L606	VK267500	COIL	220uH
PJ551	V4199100	JACK. PIN	6P
PJ552	VJ696300	JACK. PIN	4P
PJ553	V4199100	JACK. PIN	6P
PJ553	VJ696300	JACK. PIN	4P
PJ701	V2773400	JACK. PIN	1P
PJ702	VV325000	JACK. PIN	2P
PJ703	VV325000	JACK. PIN	2P
PJ704	VV325000	JACK. PIN	2P
PJ705	V2773400	JACK. PIN	1P
PJ705	VV325000	JACK. PIN	2P
PJ751	V8143900	JACK PIN	SHIELD YKC21-4348
PN581	V3750200	PIN	L=70
Q581	iC174020	TR	2SC1740S R, S
Q582	iC181510	TR	2SC1815 Y
Q601	iC174020	TR	2SC1740S R, S
Q602	VK432900	TR	2SD1915F S, T
Q603	VD678700	TR. DGT	DTC114ES
Q604	iC174020	TR	2SC1740S R, S
Q605	iC174020	TR	2SC1740S R, S
Q606	iA101510	TR	2SA1015 Y
Q607	iC224030	TR	2SC2240 GR, BL
Q608	iC053540	TR	2SC535 A, B, C
Q609	VK432900	TR	2SD1915F S, T
Q701	iC174020	TR	2SC1740S R, S
R625	HV755330	R. CAR. FP	330Ω 1/4W
R626	HV753220	R. CAR. FP	2.2Ω 1/4W
R635	HV755470	R. CAR. FP	470Ω 1/4W
R641	HV753100	R. CAR. FP	1Ω 1/4W
R642	HV753100	R. CAR. FP	1Ω 1/4W
R643	HV755470	R. CAR. FP	470Ω 1/4W
R648	HV755470	R. CAR. FP	470Ω 1/4W
R650	HV755470	R. CAR. FP	470Ω 1/4W
R686	HV755470	R. CAR. FP	470Ω 1/4W
R688	HV753470	R. CAR. FP	4.7Ω 1/4W
R716	HV755270	R. CAR. FP	270Ω 1/4W
R717	HV753220	R. CAR. FP	2.2Ω 1/4W
R719	HV753220	R. CAR. FP	2.2Ω 1/4W
R785	HV753220	R. CAR. FP	2.2Ω 1/4W
R786	HV753220	R. CAR. FP	2.2Ω 1/4W
R851	HV754470	R. CAR. FP	47Ω 1/4W
R859	HV755120	R. CAR. FP	120Ω 1/4W
R859	HV755120	R. CAR. FP	120Ω 1/4W
ST751	V4040500	SCR. TERM	M3
SW551	VY811700	SW. SLIDE	SS029-P2022BJ6-PA6
SW551	VY811700	SW. SLIDE	SS029-P2022BJ6-PA6
XL581	V7556000	RSNR. CRYST	4.332MHz HC-49U
XL601	VV949800	RSNR. CRYST	14.31818MHz
XL601	VV949900	RSNR. CRYST	17.734475MHz
	V7950100	P. C. B.	MAIN V1200
	V7950200	P. C. B.	MAIN V1200
	V7950300	P. C. B.	MAIN V1200RDS
	V7950400	P. C. B.	MAIN 5490
	V7950500	P. C. B.	MAIN 5490
	V7950700	P. C. B.	MAIN V2200

Schm Ref.	PART NO.	Description	Markets
	V7950800	P. C. B.	MAIN V2200
	V7950800	P. C. B.	MAIN V2200
CB1	V7826600	CN	16P TE TUC SERIES
CB2	LB918050	CN. BS. PIN	5P
CB4	Vi878500	CN. BS. PIN	7P
CB5	VM923600	CN. BS. PIN	13P
CB7	Vi878500	CN. BS. PIN	7P
CB8	Vi878500	CN. BS. PIN	7P
CB9	Vi878500	CN. BS. PIN	7P
CB12	Vi878200	CN. BS. PIN	4P
CB13	VK026300	CN. BS. PIN	4P
CB14	Vi878000	CN. BS. PIN	2P
CB15	V7825400	CN	4P TE TUC SERIES
CB16	Vi878000	CN. BS. PIN	2P
CB17	VB858200	CN. BS. PIN	3P
CB18	Vi878300	CN. BS. PIN	5P
CB19	Vi878300	CN. BS. PIN	5P
CB20	V7825500	CN	5P TE TUC SERIES
CB21	VB390300	CN. BS. PIN	7P
CB22	VB389800	CN. BS. PIN	2P
CB23	VB389800	CN. BS. PIN	2P
C1	UU177470	C. EL	47uF 63V
C2	UU167470	C. EL	47uF 50V
C3	UU167470	C. EL	47uF 50V
C4	UU167470	C. EL	47uF 50V
C5	VR325000	C. MYLAR	100pF 100V
C6	UU147470	C. EL	47uF 25V
C7	VR325000	C. MYLAR	100pF 100V
C8	VR325000	C. MYLAR	100pF 100V
C9	UU147470	C. EL	47uF 25V
C10	VR325000	C. MYLAR	100pF 100V
C11	UU167470	C. EL	47uF 50V
C12	UU167470	C. EL	47uF 50V
C13	VK533900	C. PP	100pF 200V
C14	UU147470	C. EL	47uF 25V
C15	VK533900	C. PP	100pF 200V
C16	VK533900	C. PP	100pF 200V
C17	UU147470	C. EL	47uF 25V
C18	VK533900	C. PP	100pF 200V
C19	VK533900	C. PP	100pF 200V
C20	UU147470	C. EL	47uF 25V
C21	VK533900	C. PP	100pF 200V
C22	UU197100	C. EL	10uF 100V
C23	VK399200	C. MYLAR. ML	0.39uF 50V
C24	VK399200	C. MYLAR. ML	0.39uF 50V
C25	UA654680	C. MYLAR	0.068uF 50V
C26	UA654680	C. MYLAR	0.068uF 50V
C27	UA654680	C. MYLAR	0.068uF 50V
C30	UU197100	C. EL	10uF 100V
C31	UU197100	C. EL	10uF 100V
C32	UU197100	C. EL	10uF 100V
C33	UU197100	C. EL	10uF 100V
C34	UU166470	C. EL	4.7uF 50V
C35	UU166470	C. EL	4.7uF 50V
C36	UU166470	C. EL	4.7uF 50V
C37	UU167470	C. EL	47uF 50V
C38	UU168100	C. EL	100uF 50V
C39	VR325000	C. MYLAR	100pF 100V
C40	UU147470	C. EL	47uF 25V
C41	VR325000	C. MYLAR	100pF 100V
C44	UU118220	C. EL	220uF 6.3V
C45	UU197100	C. EL	10uF 100V
C46	UU197100	C. EL	10uF 100V
C47	UU147100	C. EL	10uF 25V

\* New Parts

\* New Parts

RX-V1200/RX-V1200RDS/HTR-5490/RX-V2200



P.C.B. MAIN

Schm Ref.	PART NO.	Description	Markets
C48	UU137470	C. EL 47uF 16V	
C49	UA654680	C. MYLAR 0.068uF 50V	
* C50	V7405600	C. EL 12000uF 63V	
* C51	V7405600	C. EL 12000uF 63V	
C52	VK534100	C. PP 0.01uF 100V	
C53	VF467300	C. CE. TUBLR 0.01uF 16V	
C54	VF467300	C. CE. TUBLR 0.01uF 16V	
C55	UU168100	C. EL 100uF 50V	
C56	UU168100	C. EL 100uF 50V	
C57	UA654100	C. MYLAR 0.01uF 50V	RTKABG
C58	VE326400	C. MYLAR.ML 0.22uF 50V	
C61	UA654100	C. MYLAR 0.01uF 50V	RTKABG
C62	UT652100	C. PP 100pF 100V	
C63	UT652100	C. PP 100pF 100V	
C64	UA654100	C. MYLAR 0.01uF 50V	RTKABG
C65	UA653470	C. MYLAR 4700pF 50V	RTKA
C65	UA654100	C. MYLAR 0.01uF 50V	BG
C66	UA653470	C. MYLAR 4700pF 50V	RTKABG
C67	VJ599100	C. CE. TUBLR 0.1uF 50V	
C68	UA654100	C. MYLAR 0.01uF 50V	RTKABG
C69	UT652100	C. PP 100pF 100V	
C70	UT652100	C. PP 100pF 100V	
C71	UT652100	C. PP 100pF 100V	
C72	UT652100	C. PP 100pF 100V	
C73	VT898000	C. MYLAR 0.1uF 100V	
C74	VT898000	C. MYLAR 0.1uF 100V	
* C75	UA654150	C. MYLAR 0.015uF 50V	RTKA
C75	UA654220	C. MYLAR 0.022uF 50V	BG
C76	UA654100	C. MYLAR 0.01uF 50V	RTKABG
C77	UA654220	C. MYLAR 0.022uF 50V	RTKA
C77	UA654220	C. MYLAR 0.022uF 50V	BG
C78	UA654100	C. MYLAR 0.01uF 50V	RTKABG
C79	UA654100	C. MYLAR 0.01uF 50V	RTKABG
C80	UA654100	C. MYLAR 0.01uF 50V	RTKABG
C81	UA654100	C. MYLAR 0.01uF 50V	RTKABG
C82	UA654100	C. MYLAR 0.01uF 50V	RTKABG
C83	VF467300	C. CE. TUBLR 0.01uF 16V	
C84	UA655100	C. MYLAR 0.1uF 50V	
C85	UA655100	C. MYLAR 0.1uF 50V	
C86	VJ599100	C. CE. TUBLR 0.1uF 50V	
C87	UA654680	C. MYLAR 0.068uF 50V	
C88	UA654680	C. MYLAR 0.068uF 50V	
C89	UU168100	C. EL 100uF 50V	RTKABG
C90	UU167100	C. EL 10uF 50V	RTKABG
C92	UA655100	C. MYLAR 0.1uF 50V	
D1	VD631600	DIODE 1SS133, 176	
D2	VN008700	DIODE 1SS270A	
D3	VN008700	DIODE 1SS270A	
D4	VD631600	DIODE 1SS133, 176	
D5	VN008700	DIODE 1SS270A	
D6	VN008700	DIODE 1SS270A	
D7	VN008700	DIODE 1SS270A	
D8	VN008700	DIODE 1SS270A	
D9	VN008700	DIODE 1SS270A	
D10	VN008700	DIODE 1SS270A	
D11	VN008700	DIODE 1SS270A	
D12	VN008700	DIODE 1SS270A	
D13	VD631600	DIODE 1SS133, 176	
D14	VD631600	DIODE 1SS133, 176	
D15	VN008700	DIODE 1SS270A	
* D16	VG443700	DIODE.ZENR MTZ J 33.0B 33.0V	
D18	VG442600	DIODE.ZENR MTZJ24C 24V	RTKABG
D21	VN008700	DIODE 1SS270A	

\* New Parts

Schm Ref.	PART NO.	Description	Markets
D22	VG437200	DIODE.ZENR MTZJ4.7C 4.7V	
D23	VG440300	DIODE.ZENR MTZJ12C 12V	
D24	VG440300	DIODE.ZENR MTZJ12C 12V	
D25	VG440300	DIODE.ZENR MTZJ12C 12V	
D26	VG440300	DIODE.ZENR MTZJ12C 12V	
D27	VG440300	DIODE.ZENR MTZJ12C 12V	
D28	VG440300	DIODE.ZENR MTZJ12C 12V	
D29	VG440300	DIODE.ZENR MTZJ12C 12V	
D30	VG440300	DIODE.ZENR MTZJ12C 12V	
D31	VN008700	DIODE 1SS270A	
D32	VN008700	DIODE 1SS270A	
D33	VN008700	DIODE 1SS270A	
D34	VN008700	DIODE 1SS270A	
D35	VN008700	DIODE 1SS270A	
* D36	iH000920	DIODE.BRG S5VB20 3.5A 200V	
D37	VN008700	DIODE 1SS270A	
* D38	VS997800	DIODE 1T2	
* D39	VS997800	DIODE 1T2	
* D40	VS997800	DIODE 1T2	
* D41	VS997800	DIODE 1T2	
G1	V8880000	TERM.GND M3.5 RJP9899	
G2	V8880000	TERM.GND M3.5 RJP9899	
HS2	VR506800	HEAT.SINK PUH16-25	RTKABG
* IC1	X0515A00	IC LM61C1Z THERMAL	
L1	V2604200	COIL 1uH	
L2	V2604200	COIL 1uH	
L3	VU038200	COIL 0.95uH	
L4	VU038200	COIL 0.95uH	
L5	VU038200	COIL 0.95uH	
L6	V2604200	COIL 1uH	
PJ1	VP768000	JACK.PIN 2P	
PJ2	VP768000	JACK.PIN 2P	
PJ4	VP768000	JACK.PIN 2P	
PJ5	VK437600	JACK.PIN 1P	
PN1	V3750200	PIN L=70	
PN2	V3750200	PIN L=70	
PN3	V3750200	PIN L=70	
PN4	V3750200	PIN L=70	
PN5	V3750200	PIN L=70	RTKABG
* Q1	VS883300	TR 2SB1565 E, F	
Q2	VP883000	TR 2SA893A D, E	
Q3	VK432900	TR 2SD1915F S, T	
Q4	VK432900	TR 2SD1915F S, T	
Q5	VK432900	TR 2SD1915F S, T	
Q6	VP883000	TR 2SA893A D, E	
Q7	VK432900	TR 2SD1915F S, T	
Q8	VK432900	TR 2SD1915F S, T	
* Q9	V4096100	TR 2SC4614 S, T	
* Q10	V4096000	TR 2SA1770 S, T	
* Q11	V4096100	TR 2SC4614 S, T	
* Q12	V4096000	TR 2SA1770 S, T	
* Q13	V4096100	TR 2SC4614 S, T	
* Q14	V4096000	TR 2SA1770 S, T	
* Q15	V4096100	TR 2SC4614 S, T	
* Q16	V4096000	TR 2SA1770 S, T	
* Q17	V4096100	TR 2SC4614 S, T	
* Q18	V4096000	TR 2SA1770 S, T	
* Q19A	iX630850	TR 2SA1695 O, P, Y (V1200)	
* Q19A	iX606460	TR 2SA1492 O, P, Y (V2200)	
* Q19C	iX630860	TR 2SC4468 O, P, Y (V1200)	
* Q19C	iX606470	TR 2SC3856 O, P, Y (V2200)	
* Q21A	iX630850	TR 2SA1695 O, P, Y (V1200)	
* Q21A	iX606460	TR 2SA1492 O, P, Y (V2200)	

\* New Parts

RX-V1200/RX-V1200RDS/  
HTR-5490/RX-V2200

## P.C.B. MAIN

Schm Ref.	PART NO.	Description	Markets
Q21C	iX630860	TR 2SC4468 O,P,Y	(V1200)
Q21C	iX606470	TR 2SC3856 O,P,Y	(V2200)
Q23A	iX630850	TR 2SA1695 O,P,Y	(V1200)
Q23A	iX606460	TR 2SA1492 O,P,Y	(V2200)
Q23C	iX630860	TR 2SC4468 O,P,Y	(V1200)
Q23C	iX606470	TR 2SC3856 O,P,Y	(V2200)
Q25A	iX630850	TR 2SA1695 O,P,Y	(V1200)
Q25A	iX606460	TR 2SA1492 O,P,Y	(V2200)
Q25C	iX630860	TR 2SC4468 O,P,Y	(V1200)
Q25C	iX606470	TR 2SC3856 O,P,Y	(V2200)
Q27A	iX630850	TR 2SA1695 O,P,Y	(V1200)
Q27A	iX606460	TR 2SA1492 O,P,Y	(V2200)
Q27C	iX630860	TR 2SC4468 O,P,Y	(V1200)
Q27C	iX606470	TR 2SC3856 O,P,Y	(V2200)
Q29	iC181510	TR 2SC1815 Y	
Q30	VP883100	TR 2SC1890A D,E	
Q31	VP883100	TR 2SC1890A D,E	
Q32	VP883100	TR 2SC1890A D,E	
Q33	VP883100	TR 2SC1890A D,E	
Q34	VP883100	TR 2SC1890A D,E	
Q35	iA101510	TR 2SA1015 Y	
Q36	iC224030	TR 2SC2240 GR,BL	
Q37	iA097030	TR 2SA970 GR,BL	
Q38	V4096100	TR 2SC4614 S,T	
Q39	V4096000	TR 2SA1770 S,T	
Q40	VC141900	TR 2SB941 P,Q	RTKABG
Q41A	iX630850	TR 2SA1695 O,P,Y	(V1200)
Q41A	iX606460	TR 2SA1492 O,P,Y	(V2200)
Q41C	iX630860	TR 2SC4468 O,P,Y	(V1200)
Q41C	iX606470	TR 2SC3856 O,P,Y	(V2200)
Q43	iC181510	TR 2SC1815 Y	RTKABG
Q44	VP883100	TR 2SC1890A D,E	
Q45	iC181510	TR 2SC1815 Y	
Q46	iC181510	TR 2SC1815 Y	
Q47	iC181510	TR 2SC1815 Y	
Q48	iC287820	TR 2SC2878 A,B	
Q49	iC287820	TR 2SC2878 A,B	
R3	HV755100	R. CAR. FP 100Ω 1/4W	
R4	HV755100	R. CAR. FP 100Ω 1/4W	
R5	HV755100	R. CAR. FP 100Ω 1/4W	
R6	HV755100	R. CAR. FP 100Ω 1/4W	
R7	HV755100	R. CAR. FP 100Ω 1/4W	
R8	V3946100	R. MTL. OXD 2.7KΩ 0.5W	
R9	V3945100	R. MTL. OXD 390Ω 0.5W	
R10	V3945500	R. MTL. OXD 820Ω 0.5W	(V1200)
R10	V3945600	R. MTL. OXD 1KΩ 0.5W	(V2200)
R11	VP941600	R. MTL. OXD 5.6KΩ 1W	
R12	VP941600	R. MTL. OXD 5.6KΩ 1W	
R13	V3946100	R. MTL. OXD 2.7KΩ 0.5W	
R14	V3945100	R. MTL. OXD 390Ω 0.5W	
R15	V3945500	R. MTL. OXD 820Ω 0.5W	(V1200)
R15	V3945600	R. MTL. OXD 1KΩ 0.5W	(V2200)
R16	VP941600	R. MTL. OXD 5.6KΩ 1W	
R17	VP941600	R. MTL. OXD 5.6KΩ 1W	
R19	V3946100	R. MTL. OXD 2.7KΩ 0.5W	
R20	V3945100	R. MTL. OXD 390Ω 0.5W	
R21	V3945500	R. MTL. OXD 820Ω 0.5W	(V1200)
R21	V3945600	R. MTL. OXD 1KΩ 0.5W	(V2200)
R22	VP941600	R. MTL. OXD 5.6KΩ 1W	
R23	VP941600	R. MTL. OXD 5.6KΩ 1W	
R24	V3946100	R. MTL. OXD 2.7KΩ 0.5W	
R25	V3945100	R. MTL. OXD 390Ω 0.5W	
R26	V3945500	R. MTL. OXD 820Ω 0.5W	(V1200)

\* New Parts

Schm Ref.	PART NO.	Description	Markets
R26	V3945600	R. MTL. OXD 1KΩ 0.5W	(V2200)
R27	VP941600	R. MTL. OXD 5.6KΩ 1W	
R28	VP941600	R. MTL. OXD 5.6KΩ 1W	
R29	V3946100	R. MTL. OXD 2.7KΩ 0.5W	
R30	V3945100	R. MTL. OXD 390Ω 0.5W	
R31	V3945500	R. MTL. OXD 820Ω 0.5W	(V1200)
R31	V3945600	R. MTL. OXD 1KΩ 0.5W	(V2200)
R32	VP941600	R. MTL. OXD 5.6KΩ 1W	
R33	VP941600	R. MTL. OXD 5.6KΩ 1W	
R34	V3945600	R. MTL. OXD 1KΩ 0.5W	(V1200)
R34	V3945500	R. MTL. OXD 820Ω 0.5W	(V2200)
R35	V3945600	R. MTL. OXD 1KΩ 0.5W	(V1200)
R35	V3945500	R. MTL. OXD 820Ω 0.5W	(V2200)
R37	V3945600	R. MTL. OXD 1KΩ 0.5W	(V1200)
R37	V3945500	R. MTL. OXD 820Ω 0.5W	(V2200)
R38	HV754100	R. CAR. FP 10Ω 1/4W	
R39	V3945600	R. MTL. OXD 1KΩ 0.5W	(V1200)
R39	V3945500	R. MTL. OXD 820Ω 0.5W	(V2200)
R40	V3945600	R. MTL. OXD 1KΩ 0.5W	(V1200)
R40	V3945500	R. MTL. OXD 820Ω 0.5W	(V2200)
R41	V3944800	R. MTL. OXD 220Ω 0.5W	
R42	V3944800	R. MTL. OXD 220Ω 0.5W	
R44	V3944800	R. MTL. OXD 220Ω 0.5W	
R45	VP939700	R. MTL. FLM 4.7Ω 1W	
R46	VP939700	R. MTL. FLM 4.7Ω 1W	
R47	VP939700	R. MTL. FLM 4.7Ω 1W	
R48	VP939700	R. MTL. FLM 4.7Ω 1W	
R50	V3944800	R. MTL. OXD 220Ω 0.5W	
R51	V3944800	R. MTL. OXD 220Ω 0.5W	
R52	VP939700	R. MTL. FLM 4.7Ω 1W	
R53	VP939700	R. MTL. FLM 4.7Ω 1W	
R54	VP939700	R. MTL. FLM 4.7Ω 1W	
R55	VP939700	R. MTL. FLM 4.7Ω 1W	
R56	VP939700	R. MTL. FLM 4.7Ω 1W	
R57	VP939700	R. MTL. FLM 4.7Ω 1W	
R58	HV756150	R. CAR. FP 1.5KΩ 1/4W	
R59	VU981700	R. MTL. PLAT 0.22Ω+0.22 3W	
R60	VU981700	R. MTL. PLAT 0.22Ω+0.22 3W	
R61	V3873200	R. WW 0.22Ω 3W	
R64	V3873200	R. WW 0.22Ω 3W	
R65	V3873200	R. WW 0.22Ω 3W	
R84	VP939800	R. MTL. OXD 10Ω 1W	
R86	VP939800	R. MTL. OXD 10Ω 1W	
R88	VP939800	R. MTL. OXD 10Ω 1W	
R93	HV754100	R. CAR. FP 10Ω 1/4W	
R94	HV754100	R. CAR. FP 10Ω 1/4W	
R98	HV754100	R. CAR. FP 10Ω 1/4W	
R100	HV754100	R. CAR. FP 10Ω 1/4W	
R101	HV754100	R. CAR. FP 10Ω 1/4W	
R105	HV753100	R. CAR. FP 1Ω 1/4W	
R106	HV753100	R. CAR. FP 1Ω 1/4W	
R107	HV756100	R. CAR. FP 1KΩ 1/4W	
R108	HV755100	R. CAR. FP 100Ω 1/4W	
R110	HV755100	R. CAR. FP 100Ω 1/4W	
R112	V3946100	R. MTL. OXD 2.7KΩ 0.5W	
R113	V3945100	R. MTL. OXD 390Ω 0.5W	
R114	V3945600	R. MTL. OXD 1KΩ 0.5W	
R115	VP941600	R. MTL. OXD 5.6KΩ 1W	
R116	VP941600	R. MTL. OXD 5.6KΩ 1W	
R117	V3945500	R. MTL. OXD 820Ω 0.5W	
R119	V3944800	R. MTL. OXD 220Ω 0.5W	
R120	VP939700	R. MTL. FLM 4.7Ω 1W	
R121	VP939700	R. MTL. FLM 4.7Ω 1W	

\* New Parts

**P.C.B. MAIN & P.C.B. POWER**

Schm Ref.	PART NO.	Description	Markets
R122	VK187800	R. FUS	100Ω 1/4W
R122	VK187800	R. FUS	100Ω 1/4W
R123	HV756470	R. CAR. FP	4.7KΩ 1/4W
⚠	R126	VU981700	R. MTL. PLAT
⚠	R127	HV756330	R. CAR. FP
R130	HV753100	R. CAR. FP	1Ω 1/4W
R132	HV754100	R. CAR. FP	10Ω 1/4W
R132	HV754100	R. CAR. FP	10Ω 1/4W
R139	VP939800	R. MTL. OXD	10Ω 1W
R141	HV754100	R. CAR. FP	10Ω 1/4W
R143	VP940900	R. MTL. OXD	560Ω 1W
R144	VP940900	R. MTL. OXD	560Ω 1W
R147	VP940900	R. MTL. OXD	560Ω 1W
R148	VP940900	R. MTL. OXD	560Ω 1W
⚠	R185	HV753100	R. CAR. FP
⚠	R186	HV753100	R. CAR. FP
R187	VP939800	R. MTL. OXD	10Ω 1W
R188	VP939800	R. MTL. OXD	10Ω 1W
R189	VP939800	R. MTL. OXD	10Ω 1W
RY3	V6322600	RELAY	DC DH24D2-OT(M)-SL
RY4	V6322600	RELAY	DC DH24D2-OT(M)-SL
RY5	V6322600	RELAY	DC DH24D2-OT(M)-SL
RY6	V6322600	RELAY	DC DH24D2-OT(M)-SL
ST1	V4040500	SCR. TERM	M3
ST2	V4040500	SCR. TERM	M3
⚠	SW1	VZ075500	SW. SLIDE
TE1	V5912200	TERM. SP	8P LTS0810
TE1	V5912300	TERM. SP	6P LTS0810
TE2	V5912200	TERM. SP	8P LTS0810
TE2	V5912300	TERM. SP	6P LTS0810
	V5995800	PLATE. GND	
	V2128100	SCR. BW. HD	3x12-8 MFZN2Y
	EP600140	SCR. BND. HD	3x10 MFZN2BL
	V7945500	P. C. B.	POWER V1200
	V7945600	P. C. B.	POWER V1200
	V7945700	P. C. B.	POWER V1200
	V7945800	P. C. B.	POWER V1200
	V7945900	P. C. B.	POWER V1200RDS
	V7946000	P. C. B.	POWER V1200RDS
	V8024100	P. C. B.	POWER 5490
	V8024200	P. C. B.	POWER 5490
	V8024500	P. C. B.	POWER 5490
	V7946200	P. C. B.	POWER V2200
	V7946300	P. C. B.	POWER V2200
	V7946400	P. C. B.	POWER V2200
	V7946500	P. C. B.	POWER V2200
	CB201	V7827100	SOCKET
	CB204	VP206500	HOLDER. FUS
	CB205	VP206500	HOLDER. FUS
	CB206	VG879900	CN. BS. PIN
	CB207	VP206500	HOLDER. FUS
	CB208	VP206500	HOLDER. FUS
	CB209	VP206500	HOLDER. FUS
	CB210	VP206500	HOLDER. FUS
	CB211	VB858800	CN. BS. PIN
	CB212	VQ044900	CN. BS. PIN
	CB213	V7827200	SOCKET
	CB215	V7828300	SOCKET
	CB216	VB389800	CN. BS. PIN
	CB217	V6561200	AC INLET

\* New Parts

Schm Ref.	PART NO.	Description	Markets
CB218	VQ584900	CN. BS. PIN	7P
CB219	VQ584900	CN. BS. PIN	7P
CB851	VQ044500	CN. BS. PIN	11P
CB852	VQ044400	CN. BS. PIN	9P
C201	UR848470	C. EL	470uF 25V
C202	UU147100	C. EL	10uF 25V
C202	UU147100	C. EL	10uF 25V
C203	UR897100	C. EL	10uF 100V
C204	UU167100	C. EL	10uF 50V
C206	UA655100	C. MYLAR	0.1uF 50V
C207	UA655100	C. MYLAR	0.1uF 50V
C208	UA655100	C. MYLAR	0.1uF 50V
C209	UA655100	C. MYLAR	0.1uF 50V
C210	UU149680	C. EL	6800uF 25V
C211	UU149330	C. EL	3300uF 25V
C212	UU13A100	C. EL	10000uF 16V
C213	UU13A100	C. EL	10000uF 16V
C214	UU13A100	C. EL	10000uF 16V
C215	UU139680	C. EL	6800uF 16V
C216	Vi716700	C. MYLAR	0.01uF 50V
C217	VL884600	C. PP	0.01uF 100V
C218	Vi716700	C. MYLAR	0.01uF 50V
C219	UU147100	C. EL	10uF 25V
C220	UU13A100	C. EL	10000uF 16V
C221	UU13A100	C. EL	10000uF 16V
⚠	C222	V6185300	C. CE. SAFTY
C223	UU138100	C. EL	100uF 16V
C224	UU147100	C. EL	10uF 25V
C225	UU147100	C. EL	10uF 25V
C226	UU147100	C. EL	10uF 25V
C227	UU138100	C. EL	100uF 16V
C228	UU147100	C. EL	10uF 25V
C229	UU147100	C. EL	10uF 25V
C230	UU138100	C. EL	100uF 16V
C231	UU138100	C. EL	100uF 16V
C232	UU138100	C. EL	100uF 16V
C233	UU138100	C. EL	100uF 16V
C234	UU147100	C. EL	10uF 25V
C235	UU147100	C. EL	10uF 25V
C236	UU147100	C. EL	10uF 25V
C237	UU147100	C. EL	10uF 25V
C238	UU147100	C. EL	10uF 25V
C239	UU147100	C. EL	10uF 25V
C240	VK534000	C. PP	220pF 200V
C241	UU177220	C. EL	22uF 63V
C242	UR819100	C. EL	1000uF 6.3V
C243	UR819100	C. EL	1000uF 6.3V
C244	VQ462600	C. MYLAR	220pF 50V
C244	VQ645600	C. MYLAR	100pF 50V
C245	VQ462600	C. MYLAR	220pF 50V
C246	VQ462600	C. MYLAR	220pF 50V
C246	VQ645600	C. MYLAR	100pF 50V
C247	VQ462600	C. MYLAR	220pF 50V
C248	VQ462600	C. MYLAR	220pF 50V
C248	VQ645600	C. MYLAR	100pF 50V
C249	UA652220	C. MYLAR	220pF 50V
C250	VQ462600	C. MYLAR	220pF 50V
C250	VQ462600	C. MYLAR	220pF 50V
C250	VQ645600	C. MYLAR	100pF 50V
C251	UA652220	C. MYLAR	220pF 50V
C252	VQ462600	C. MYLAR	220pF 50V
C252	VQ645600	C. MYLAR	100pF 50V
C253	VQ462600	C. MYLAR	220pF 50V

\* New Parts

RX-V1200/RX-V1200RDS/HTR-5490/RX-V2200

**P.C.B. POWER**

Schm Ref.	PART NO.	Description	Markets
C254	VQ462600	C. MYLAR 220pF 50V	RTKABG
C254	VQ645600	C. MYLAR 100pF 50V	UC
C255	UA652220	C. MYLAR 220pF 50V	
C256	UU138100	C. EL 100uF 16V	
C257	UU177220	C. EL 22uF 63V	
C258	UA653100	C. MYLAR 1000pF 50V	
C259	VQ463300	C. PP 22pF 630V	
C260	UU168100	C. EL 100uF 50V	
C261	UA653100	C. MYLAR 1000pF 50V	
C262	VQ463300	C. PP 22pF 630V	
C263	UU168100	C. EL 100uF 50V	
C264	UA653100	C. MYLAR 1000pF 50V	
C265	VS696700	C. CE 33pF 500V	
C266	UU157470	C. EL 47uF 35V	
C267	UA653100	C. MYLAR 1000pF 50V	
C268	VS696700	C. CE 33pF 500V	
C269	UU157470	C. EL 47uF 35V	
C270	UA653100	C. MYLAR 1000pF 50V	
C271	VQ245400	C. PP 33pF 200V	
C272	UU157470	C. EL 47uF 35V	
C273	UA653100	C. MYLAR 1000pF 50V	
C274	VS696700	C. CE 33pF 500V	
C275	UU157470	C. EL 47uF 35V	
C851	VJ599100	C. CE. TUBLR 0. 1uF 50V	
C852	VF467000	C. CE. TUBLR 1000pF 50V	UCA
D201	VD631600	DIODE 1SS133, 176	
D201	VD631600	DIODE 1SS133, 176	RTK
D202	VS997800	DIODE 1T2	RTK
D202	VS997800	DIODE 1T2	
D203	VS997800	DIODE 1T2	
D204	VS997800	DIODE 1T2	
D205	VS997800	DIODE 1T2	
D206	VS997800	DIODE 1T2	
D207	VG439900	DIODE. ZENR MTZJ11B 11V	
D207	VG439900	DIODE. ZENR MTZJ11B 11V	RTK
D208	V4269600	DIODE. BRG D2SBA20 1. 5A 200V	
D209	V4269600	DIODE. BRG D2SBA20 1. 5A 200V	
D210	VD631600	DIODE 1SS133, 176	
D211	VD631600	DIODE 1SS133, 176	
D212	VG440300	DIODE. ZENR MTZJ12C 12V	
D213	VG439100	DIODE. ZENR MTZJ9. 1A 9. 1V EX	
D214	VG440300	DIODE. ZENR MTZJ12C 12V	
D215	VG440100	DIODE. ZENR MTZJ12A 12V	UC (V1200)
D215	VG441600	DIODE. ZENR MTZJ20A 20V	RTKABG
D215	VG440800	DIODE. ZENR MTZJ15B 15V	RTA (V2200)
D215	VG441600	DIODE. ZENR MTZJ20A 20V	UC (V2200)
D216	VD631600	DIODE 1SS133, 176	
D217	VD631600	DIODE 1SS133, 176	
D851	VD631600	DIODE 1SS133, 176	UCA
F201	VS823300	FUSE T8. 0A 125V	U
F201	VT942900	FUSE TH2. 5A 250V	G
F202	KB000790	FUSE T4. 0A 250V	ABG
F202	VS823300	FUSE T8. 0A 125V	UCRTK
F203	KB000790	FUSE T4. 0A 250V	RTK
IC201	XJ607A00	IC NJM7805FA 5V	
IC202	XJ607A00	IC NJM7805FA 5V	
IC203	XJ602A00	IC NJM78M12FA	
IC204	XD343A00	IC NJM79M12FA	
IC205	XJ607A00	IC NJM7805FA 5V	
IC206	XE436A00	IC NJM79M05FA	
JK851	VJ726800	JACK. MNI	UCA
JK852	VJ726800	JACK. MNI	UCA
JK853	VJ726800	JACK. MNI	UCA

\* New Parts

Schm Ref.	PART NO.	Description	Markets
L201	VP133800	FER. BEAD BL02RN1-R62T4	
PN2	V3750200	PIN L=70	
PN3	V3750200	PIN L=70	
PN4	V3750200	PIN L=70	
PN851	V3750200	PIN L=70	
Q201	VR510800	TR 2SD2396 J, K	RTK
Q202	VR510800	TR 2SD2396 J, K	RTK
Q203	iE102620	FET 2SK246 Y	RTK
Q204	iC174020	TR 2SC1740S R, S	
Q205	VR510800	TR 2SD2396 J, K	
Q206	VP883100	TR 2SC1890A D, E EX	
Q206	VP883100	TR 2SC1890A D, E	
Q207	VP883100	TR 2SC1890A D, E	
Q208	VP883100	TR 2SC1890A D, E	
Q209	VP883100	TR 2SC1890A D, E	
Q210	VP883100	TR 2SC1890A D, E	
Q211	VP883100	TR 2SC1890A D, E	
Q212	VP883100	TR 2SC1890A D, E	
Q213	VP883100	TR 2SC1890A D, E	
Q214	V3966800	TR 2SB949 O, Y	
Q215	VP883100	TR 2SC1890A D, E	
Q216	V3966800	TR 2SB949 O, Y	
Q217	VP883100	TR 2SC1890A D, E	
Q218	V3966800	TR 2SB949 O, Y	
Q219	VP883100	TR 2SC1890A D, E	
Q220	V3966800	TR 2SB949 O, Y	
Q221	VP883100	TR 2SC1890A D, E	
Q222	V3966800	TR 2SB949 O, Y	
Q223	VP883100	TR 2SC1890A D, E	
Q224	V3966800	TR 2SB949 O, Y	
Q225	VP883100	TR 2SC1890A D, E	
R209	V6730000	R. CAR. 2. 2MΩ 1/2W	UC
R210	VP939500	R. MTL. FLM 1Ω 1W	
R211	VP939500	R. MTL. FLM 1Ω 1W	
R212	HV753100	R. CAR. FP 1Ω 1/4W	
R213	HV753100	R. CAR. FP 1Ω 1/4W	
R214	VP939500	R. MTL. FLM 1Ω 1W	
R215	VP939500	R. MTL. FLM 1Ω 1W	
R248	HV754100	R. CAR. FP 10Ω 1/4W	
R249	HV756470	R. CAR. FP 4. 7KΩ 1/4W	
R252	HV754470	R. CAR. FP 47Ω 1/4W	
R258	HV754470	R. CAR. FP 47Ω 1/4W	
R264	HV754470	R. CAR. FP 47Ω 1/4W	
R270	HV754470	R. CAR. FP 47Ω 1/4W	
R276	HV754470	R. CAR. FP 47Ω 1/4W	
R282	HV754470	R. CAR. FP 47Ω 1/4W	
RY201	V6017400	RELAY DC SDT-S-112LMR2	URTKABG
RY201	V6434900	RELAY DC DLS12D1-0(M)	C
ST2	V4040500	SCR. TERM M3	
ST3	V4040500	SCR. TERM M3	
ST4	V4040500	SCR. TERM M3	UC
ST851	V4040500	SCR. TERM M3	
ST852	V4040500	SCR. TERM M3	
SW202	V7182300	VOLT. SELCT R8140213	RTK
T201	XZ228A00	TRANS. PWR	UC
T201	XZ229A00	TRANS. PWR	RTK
T201	XZ230A00	TRANS. PWR	A
T201	XZ231A00	TRANS. PWR	BG
TE201	V5867400	OUTLET. AC 2P AC-182-GB-11V	RTK
TE201	VT915000	OUTLET. AC 2P	A
TE201	VU543100	OUTLET. AC 2P	UC
TE201	VU543300	OUTLET. AC 1P	B
TE201	VU543400	OUTLET. AC 2P	G

\* New Parts

1

<b>P.C.B. POWER &amp; Chip Resistors</b>
--

2

3

4

5

6

7

Schm Ref.	PART NO.	Description	Markets
	EP600140	SCR. BND. HD	3x10 MFZ2BL RTK
	RD350000	R. CAR. CHP	0Ω 1/10W
	RD353220	R. CAR. CHP	2.2Ω 1/10W
	RD354330	R. CAR. CHP	33Ω 1/10W
	RD354470	R. CAR. CHP	47Ω 1/10W
	RD354750	R. CAR. CHP	75Ω 1/10W
	RD354820	R. CAR. CHP	82Ω 1/10W
	RD355100	R. CAR. CHP	100Ω 1/10W
	RD355150	R. CAR. CHP	150Ω 1/10W
	RD355220	R. CAR. CHP	220Ω 1/10W
	RD355330	R. CAR. CHP	330Ω 1/10W
	RD355390	R. CAR. CHP	390Ω 1/10W
	RD355470	R. CAR. CHP	470Ω 1/10W
	RD355680	R. CAR. CHP	680Ω 1/10W
	RD355820	R. CAR. CHP	820Ω 1/10W
	RD355910	R. CAR. CHP	910Ω 1/16W
	RD356100	R. CAR. CHP	1KΩ 1/10W
	RD356120	R. CAR. CHP	1.2KΩ 1/10W
	RD356150	R. CAR. CHP	1.5KΩ 1/10W
	RD356180	R. CAR. CHP	1.8KΩ 1/10W
	RD356220	R. CAR. CHP	2.2KΩ 1/10W
	RD356240	R. CAR. CHP	2.4KΩ 1/10W
	RD356270	R. CAR. CHP	2.7KΩ 1/10W
	RD356330	R. CAR. CHP	3.3KΩ 1/10W
	RD356390	R. CAR. CHP	3.9KΩ 1/10W
	RD356470	R. CAR. CHP	4.7KΩ 1/10W
	RD356510	R. CAR. CHP	5.1KΩ 1/10W
	RD356560	R. CAR. CHP	5.6KΩ 1/10W
	RD356620	R. CAR. CHP	6.2KΩ 1/10W
	RD356680	R. CAR. CHP	6.8KΩ 1/10W
	RD356820	R. CAR. CHP	8.2KΩ 1/10W
	RD356910	R. CAR. CHP	9.1KΩ 1/10W
	RD357100	R. CAR. CHP	10KΩ 1/10W
	RD357120	R. CAR. CHP	12KΩ 1/10W
	RD357150	R. CAR. CHP	15KΩ 1/10W
	RD357180	R. CAR. CHP	18KΩ 1/10W
	RD357220	R. CAR. CHP	22KΩ 1/10W
	RD357330	R. CAR. CHP	33KΩ 1/10W
	RD357470	R. CAR. CHP	47KΩ 1/10W
	RD357560	R. CAR. CHP	56KΩ 1/10W
	RD357820	R. CAR. CHP	82KΩ 1/10W
	RD358100	R. CAR. CHP	100KΩ 1/10W
	RD358330	R. CAR. CHP	330KΩ 1/10W
	RD358470	R. CAR. CHP	470KΩ 1/10W
	RD358680	R. CAR. CHP	680KΩ 1/10W
	RD359100	R. CAR. CHP	1MΩ 1/10W
	RD359220	R. CAR. CHP	2.2MΩ 1/10W

\* New Parts

Schm Ref.	PART NO.	Description	Markets

\* New Parts

# ■ RX-V1200/RX-V1200RDS/HTR-5490 EXPLODED VIEW

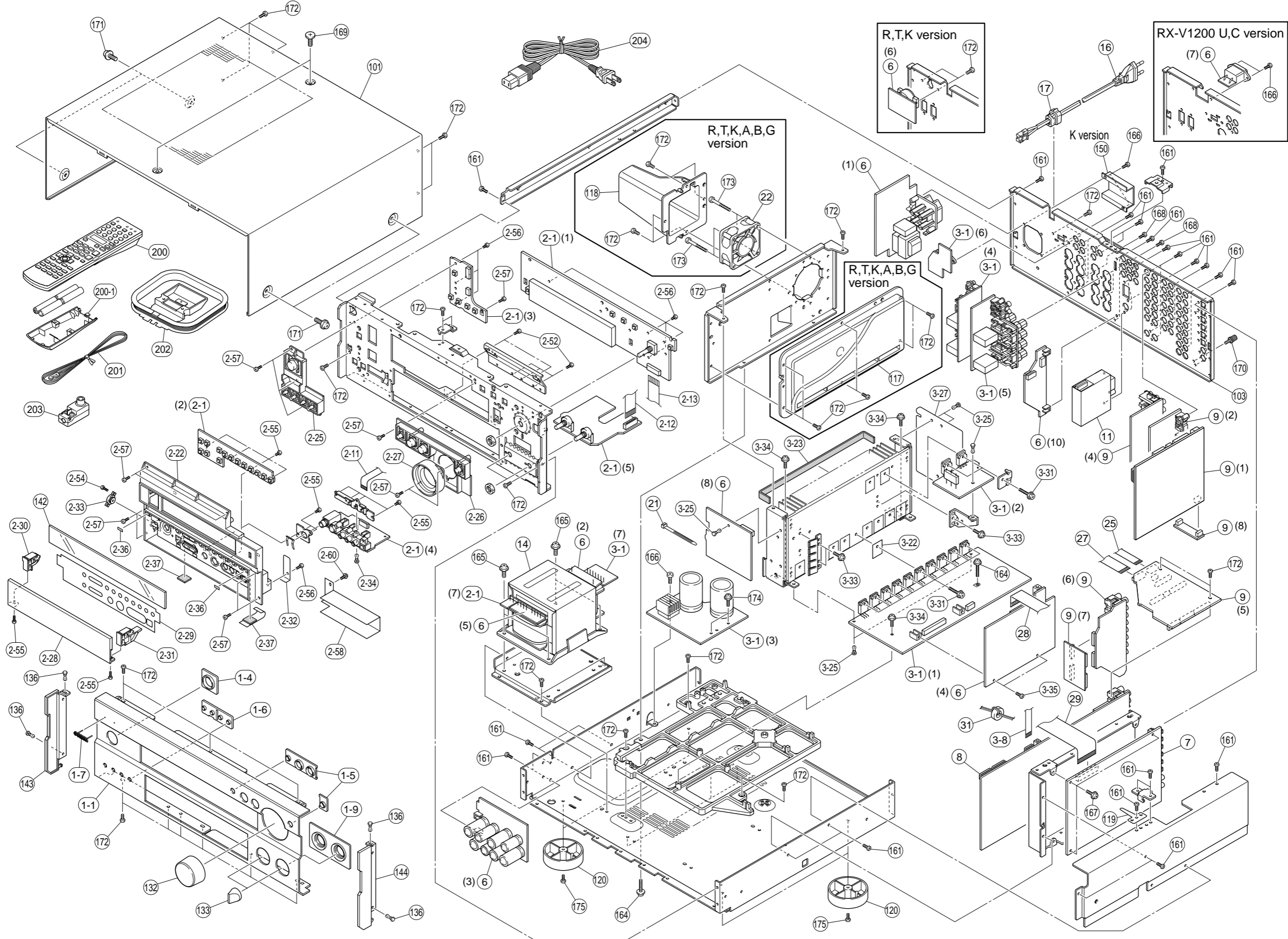

## ■ RX-V1200/RX-V1200RDS/HTR-5490 MECHANICAL PARTS

Ref. No.	PART NO.	Description	Remarks	Markets	
*	1-1	V7619300	FRONT PANEL	V1200BL	
*	1-1	V7619400	FRONT PANEL	V1200GD	
*	1-1	V7619600	FRONT PANEL	V1200RDSBL	
*	1-1	V7619700	FRONT PANEL	V1200RDSGD	
*	1-1	V7619900	FRONT PANEL	V1200RDST I	
*	1-1	V7620300	FRONT PANEL	5490GD	
*	1-1	V7620200	FRONT PANEL	5490BL	
	1-4	V6003800	ESCUTCHEON/POWER	V1200BL, 5490BL	
	1-4	V6003900	ESCUTCHEON/POWER	V1200GD, 5490GD	
	1-4	V6004000	ESCUTCHEON/POWER	V1200T I	
	1-5	V6004100	ESCUTCHEON/INPUT	V1200BL, 5490BL	
	1-5	V6004200	ESCUTCHEON/INPUT	V1200GD, 5490GD	
	1-5	V6004300	ESCUTCHEON/INPUT	V1200T I	
	1-6	V6004400	ESCUTCHEON/D5		
	1-7	V6034100	EMBLEM	V1200BL, V1200T I	
	1-7	V6034200	EMBLEM	V1200GD, 5490G/B	
*	1-9	V7622500	ESCUTCHEON/TC	V1200BL, 5490BL	
*	1-9	V7622600	ESCUTCHEON/TC	V1200GD, 5490GD	
*	1-9	V7622800	ESCUTCHEON/TC	V1200T I	
*	2-1	V7951000	P.C.B. ASS'Y	OPERATION	UCA
*	2-1	V7951100	P.C.B. ASS'Y	OPERATION	BG
*	2-1	V7950900	P.C.B. ASS'Y	OPERATION	RTK
	2-11	MF207350	S FLEXIBLE FLAT CABLE	7P 350mm	
	2-12	MF117160	FLEXIBLE FLAT CABLE	17P 160mm	
*	2-13	MF219250	S FLEXIBLE FLAT CABLE	19P 250mm P=1.25	
	2-22	V6000000	SUB PANEL/CASE	V1200BL, 5490BL	
	2-22	V6019600	SUB PANEL/CASE	V1200RDSBL	
	2-22	V6000100	SUB PANEL/CASE	V1200GD, 5490GD	
	2-22	V6019700	SUB PANEL/CASE	V1200RDSGD	
	2-22	V6019800	SUB PANEL/CASE	V1200RDST I	
*	2-25	V7794700	BUTTON P/S	V1200BL	
*	2-25	V7794800	BUTTON P/S	V1200GD	
*	2-25	V7794900	BUTTON P/S	V1200T I, 5490GD	
*	2-25	V7795000	BUTTON P/S	5490BL	
	2-26	V6000400	BUTTON/INPUT	V1200GD	
	2-26	V6000500	BUTTON/INPUT	V1200T I, 5490GD	
	2-26	V6000300	BUTTON/INPUT	V1200BL, 5490BL	
	2-27	V6004500	ESCUTCHEON, VOL	V1200BL, 5490BL	
	2-27	V6004600	ESCUTCHEON, VOL	V1200GD	
	2-27	V6004700	ESCUTCHEON, VOL	V1200T I, 5490GD	
*	2-28	V7621500	PANEL, LID	V1200BL, 5490BL	
*	2-28	V7621800	PANEL, LID	V1200T I	
*	2-28	V7621600	PANEL, LID	V1200GD, 5490GD	
*	2-29	V7795100	PLATE, SP	V1200BL	
*	2-29	V7795400	PLATE, SP	V1200RDSBL	
*	2-29	V7795600	PLATE, SP	V1200RDST I	
*	2-29	V7795300	PLATE, SP	5490BL	
*	2-29	V7795200	PLATE, SP	V1200GD, 5490GD	
*	2-29	V7795500	PLATE, SP	V1200RDSGD	
	2-30	V6005100	HINGE, L	V1200GD, 5490GD	
	2-30	V6005200	HINGE, L	V1200T I	
	2-30	V6005000	HINGE, L	V1200BL, 5490BL	
	2-31	V6005300	HINGE, R	V1200BL, 5490BL	

\* New Parts

RX-V1200/RX-V1200RDS/HTR-5490/RX-V2200

Ref. No.	PART NO.	Description	Remarks	Markets
2-31	V6005400	HINGE, R	V1200GD, 5490GD	
2-31	V6005500	HINGE, R	V1200TI	
2-32	V4593300	SPRING, LID		
2-33	VZ830300	DAMPER, GEAR	15G	
2-34	VQ368600	PUSH RIVET	P3555-B	
2-36	VY940400	CUSHION, LID	T=0.8	
2-37	VV982000	DAMPER	1x12x12	
2-52	VN413300	BIND HEAD BONDING B-T. SCREW	3x8 MFZN2BL	
2-54	VG893800	BIND HEAD P-TITE SCREW	2x6 MFZN2BL	
2-55	VG863900	BIND HEAD TAPPING SCREW	2.6x6 MFZN2BL	
2-56	EP630290	BIND HEAD P-TITE SCREW	3x6 MFC2BL	
2-57	EP600250	BIND HEAD B-TITE SCREW	3x8 MFZN2Y	
* 2-58	V8205900	SHEET/SHIELD		
2-60	VJ204800	PW HEAD S-TITE SCREW	3x6-8 MFC2BL	
* △ 3-1	V7950100	P.C.B. ASS'Y	MAIN	V1200 UC
* △ 3-1	V7950400	P.C.B. ASS'Y	MAIN	5490 UC
* △ 3-1	V7950300	P.C.B. ASS'Y	MAIN	V1200RDS BG
* △ 3-1	V7950200	P.C.B. ASS'Y	MAIN	V1200 RTKA
* △ 3-1	V7950500	P.C.B. ASS'Y	MAIN	5490 T
3-8	MF113250	FLEXIBLE FLAT CABLE	13P 250mm	
3-22	VV849300	SHEET	19x24	
3-23	V5454200	DAMPER	2/10/260	
3-25	VQ368600	PUSH RIVET	P3555-B	
* 3-27	V8152100	SHEET		
3-31	VK173200	SCREW, TRANSISTOR	3x15 SP MFC2	
3-33	V7669300	PW HEAD B-TITE SCREW	3x8-8 MFC2	
3-34	VB770200	PW HEAD P-TITE SCREW	3x10-8 MFC2	
3-35	EP630210	BIND HEAD S-TITE SCREW	3x6 MFZN2BL	
* △ 6	V7945500	P.C.B. ASS'Y	POWER	V1200 U
* △ 6	V7945600	P.C.B. ASS'Y	POWER	V1200 C
* △ 6	V7945700	P.C.B. ASS'Y	POWER	V1200, 5490 RTK
* △ 6	V7945800	P.C.B. ASS'Y	POWER	V1200 A
* △ 6	V7945900	P.C.B. ASS'Y	POWER	V1200 B
* △ 6	V7946000	P.C.B. ASS'Y	POWER	V1200 G
* △ 6	V8024100	P.C.B. ASS'Y	POWER	5490 U
* △ 6	V8024200	P.C.B. ASS'Y	POWER	5490 C
* △ 6	V8024500	P.C.B. ASS'Y	POWER	5490 A
* 7	V7946700	P.C.B. ASS'Y	DSP	V1200, 5490
* 8	V7944400	P.C.B. ASS'Y	FUNCTION	V1200 UC
* 8	V7944500	P.C.B. ASS'Y	FUNCTION	V1200, 5490 RTK
* 8	V7944600	P.C.B. ASS'Y	FUNCTION	V1200 A
* 8	V7944700	P.C.B. ASS'Y	FUNCTION	V1200RDS BG
* 8	V7944800	P.C.B. ASS'Y	FUNCTION	5490 UC
* 8	V7944900	P.C.B. ASS'Y	FUNCTION	5490 A
* 9	V7947100	P.C.B. ASS'Y	VIDEO	V1200 UC
* 9	V7947200	P.C.B. ASS'Y	VIDEO	V1200 RTK
* 9	V7947300	P.C.B. ASS'Y	VIDEO	V1200 A
* 9	V7947400	P.C.B. ASS'Y	VIDEO	V1200RDS BG
* 9	V7947500	P.C.B. ASS'Y	VIDEO	5490 UC
* 9	V7947600	P.C.B. ASS'Y	VIDEO	5490 T
* 9	V7947700	P.C.B. ASS'Y	VIDEO	5490 A
11	V7424300	AM/FM TUNER	FAE350-A10F UCRTK	UCRTK
11	V7424400	AM/FM TUNER	FAE404-E10F ABGL	ABG

\* New Parts



Ref. No.	PART NO.	Description	Remarks	Markets
* 14	X0464A00	POWER TRANSFORMER		U
* 14	X0465A00	POWER TRANSFORMER		C
* 14	X0466A00	POWER TRANSFORMER		RTK
* 14	X0467A00	POWER TRANSFORMER		A
* 14	X0468A00	POWER TRANSFORMER		BG
16	V2296800	POWER CORD ASS'Y		A
16	V2363800	POWER CORD ASS'Y	5490	UC
* 16	V8013000	POWER CORD ASS'Y		K
16	VN363700	POWER CORD ASS'Y		G
16	VV437300	POWER CORD ASS'Y		B
16	VZ542500	POWER CORD ASS'Y		RT
17	V2438700	CORD STOPPER	10P1	
21	VZ625600	BINDING TIE	SE140 L=140	
22	VV272500	DC FAN MOTOR	2410ML -05W-B20-L00	RTKABG
25	MF111100	FLEXIBLE FLAT CABLE	11P 100mm	
27	MF115100	FLEXIBLE FLAT CABLE C&C	15P 100mm	
* 28	MF119160	FLEXIBLE FLAT CABLE	19P 160mm P=1.25	
29	MF131100	FLEXIBLE FLAT CABLE	31P 100mm	
31	Vi491100	FERRITE CORE	BP53RB19012080M	
* 101	V7640600	TOP COVER		BL
* 101	V7640700	TOP COVER		GD
* 101	V7640800	TOP COVER		TI
* 103	V7617300	REAR PANEL		V1200 U
* 103	V7617400	REAR PANEL		V1200 C
* 103	V7617500	REAR PANEL		V1200 RTK
* 103	V7617600	REAR PANEL		V1200 A
* 103	V7617900	REAR PANEL		V1200RDS B
* 103	V7618000	REAR PANEL		V1200RDS G
* 103	V7618900	REAR PANEL		5490 U
* 103	V7619000	REAR PANEL		5490 C
* 103	V7619100	REAR PANEL		5490 T
* 103	V7619200	REAR PANEL		5490 A
* 117	V7623000	BRACKET/FAN		RTKABG
* 118	V7622900	DUCT/FAN		RTKABG
119	VQ775900	GROUND PLATE		
120	V0042500	LEG	D60xH21	V1200GD, 5490GD
120	VS025000	LEG	D60xH21	V1200BL, V1200TI
120	VV544300	LEG	D60xH21	5490BL
132	V6002200	KNOB D43		5490BL
132	V6002300	KNOB D43		5490GD
132	V6068000	KNOB/D43		V1200BL
132	V6068100	KNOB/D43		V1200GD
132	V6077800	KNOB D43		V1200TI
133	V6001300	KNOB D20		BL
133	V6001400	KNOB D20		GD
133	V6001500	KNOB D20		TI
136	VQ368600	PUSH RIVET	P3555-B	
* 142	V7796200	SHEET, WINDOW		
143	V6002500	PLATE/SIDE L		BL
143	V6002700	PLATE/SIDE L		GD
143	V6002800	PLATE/SIDE L		TI
144	V6002900	PLATE/SIDE R		BL
144	V6003000	PLATE/SIDE R		GD

\* New Parts



Ref. No.	PART NO.	Description	Remarks	Markets
144	V6003100	PLATE/SIDE R		TI
150	V8466300	COVER/AC OUTLETS		K
161	VN413300	BIND HEAD BONDING B-T. SCREW	3x8 MFZN2BL	
164	VT669400	PW HEAD B-TITE SCREW	3x15-8 MFC2	
165	21991500	PW HEAD S-TITE SCREW	4x8-10 MFC2BL	
166	EP600250	BIND HEAD B-TITE SCREW	3x8 MFZN2Y	
167	VT669300	PW HEAD B-TITE SCREW	3x8-8 MFC2	
168	VY731200	BONDING HEAD TAPPING SCREW	3x10 MFN133	
169	VK522000	SPECIAL SCREW S-TITE	4x8-10 MFC2BL	BL
169	VK522100	SPECIAL SCREW S-TITE	4x8-10 MFC2BL	TI
169	VZ893000	DECORATED SCREW S-TIGHT	4x8-10 MFN133	GD
170	AA627310	GROUND TERMINAL		
171	21991500	PW HEAD S-TITE SCREW	4x8-10 MFC2BL	BL
171	VD069600	PW HEAD S-TITE SCREW	4x8-10 MFN133	GD
171	VH313200	BW HEAD S-TITE SCREW	4x8-10 MFN13BL	TI
172	EP630210	BIND HEAD S-TITE SCREW	3x6 MFZN2BL	
173	VV220300	BIND HEAD B-TITE SCREW	3x30 MFZN2BL	RTKABG
174	VB770200	PW HEAD P-TITE SCREW	3x10-8 MFC2	
175	EP600130	BIND HEAD B-TITE SCREW	3x6 MFZN2Y	
		ACCESSORIES		
* 200	V7545800	REMOTE CONTROL TRANSMITTER	RAV230	BW0900 UCRATK
* 200	V7545900	REMOTE CONTROL TRANSMITTER	RAV231	BW0901 BG
* 200-1	AAX31620	LID	71-0900-02000	71 0900 02000
201	V6267000	ANTENNA, FM	1.4m 1pc	UCRTK
201	VQ147100	ANTENNA, FM	1.4m 1pc	ABG
202	VR248500	ANTENNA, AM LOOP	1.0m 1pc	
203	VE364900	ANTENNA ADAPTER	PAL 75-300	B
* 204	V6545800	POWER CORD ASS'Y BATTERY, MANGANESE	INLET 2.0m UM-4NE (2PC)	V1200 UC

\* New Parts

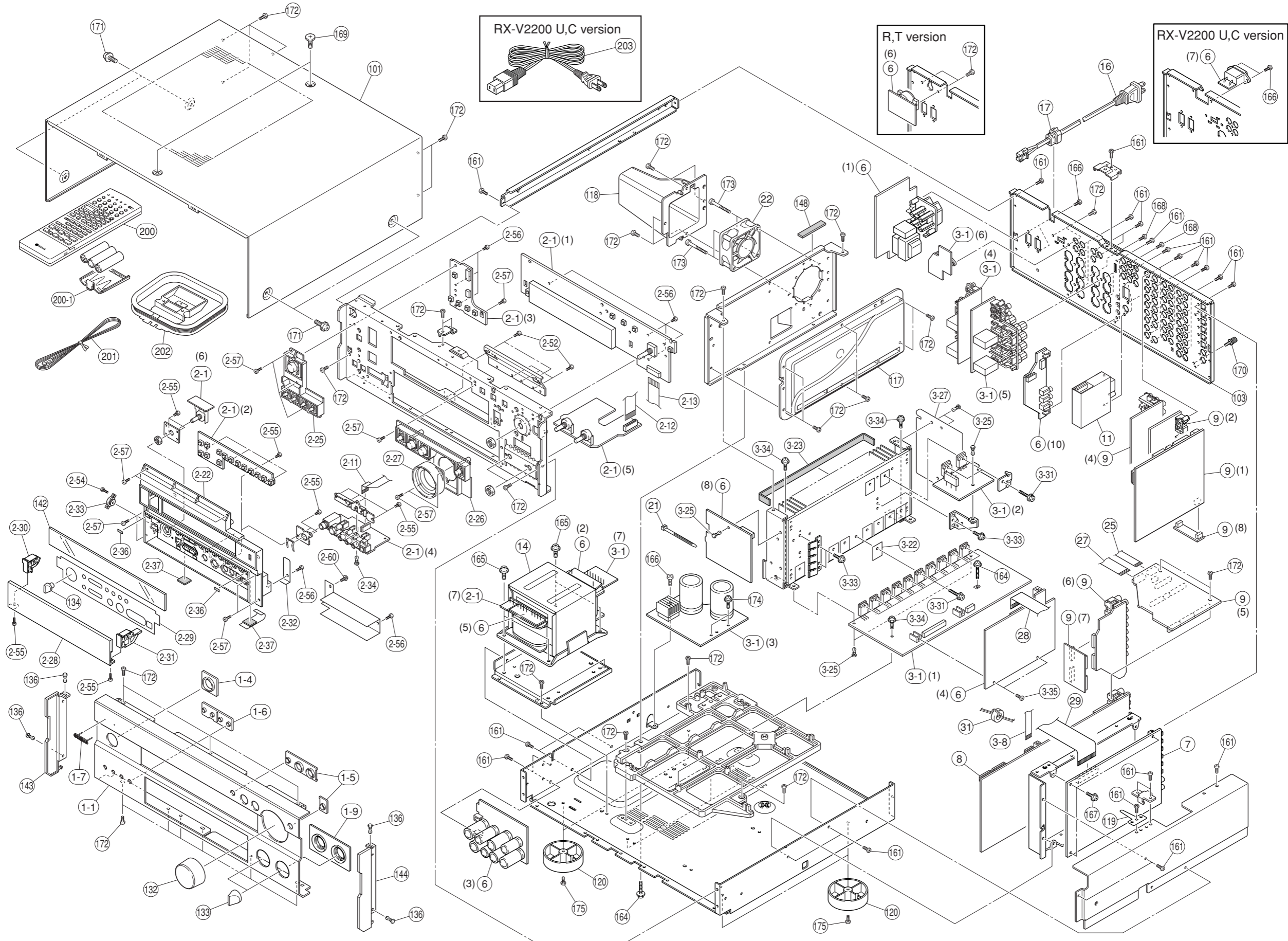
# ■ RX-V2200 EXPLODED VIEW













■ RX-V2200 MECHANICAL PARTS

Ref. No.	PART NO.	Description	Remarks	Markets	
*	1-1	V7620600	FRONT PANEL	RXV2200GD	
*	1-1	V7620500	FRONT PANEL	RXV2200BL	
	1-4	V6003900	ESCUTCHEON/POWER	GD	
	1-4	V6003800	ESCUTCHEON/POWER	BL	
	1-5	V6004200	ESCUTCHEON/INPUT	GD	
	1-5	V6004100	ESCUTCHEON/INPUT	BL	
	1-6	V6004400	ESCUTCHEON/D5		
	1-7	V6034200	EMBLEM	GD	
	1-7	V6034100	EMBLEM	BL	
*	1-9	V7622600	ESCUTCHEON/TC	GD	
*	1-9	V7622500	ESCUTCHEON/TC	BL	
*	2-1	V7951300	P.C.B. ASS'Y	OPERATION	
	2-11	MF207350	S FLEXIBLE FLAT CABLE	7P 350mm	
	2-12	MF117160	FLEXIBLE FLAT CABLE	17P 160mm	
*	2-13	MF219250	S FLEXIBLE FLAT CABLE	19P 250mm P=1.25	
	2-22	V6000100	SUB PANEL/CASE	GD	
	2-22	V6000000	SUB PANEL/CASE	BL	
*	2-25	V7794800	BUTTON P/S	GD	
*	2-25	V7794700	BUTTON P/S	BL	
	2-26	V6000400	BUTTON/INPUT	GD	
	2-26	V6000300	BUTTON/INPUT	BL	
	2-27	V6004600	ESCUTCHEON, VOL	GD	
	2-27	V6004500	ESCUTCHEON, VOL	BL	
*	2-28	V7622000	PANEL, LID	GD	
*	2-28	V7621900	PANEL, LID	BL	
*	2-29	V7795800	PLATE, SP	GD	
*	2-29	V7795700	PLATE, SP	BL	
	2-30	V6005100	HINGE, L	GD	
	2-30	V6005000	HINGE, L	BL	
	2-31	V6005400	HINGE, R	GD	
	2-31	V6005300	HINGE, R	BL	
	2-32	V4593300	SPRING, LID		
	2-33	VZ830300	DAMPER, GEAR	15G	
	2-34	VQ368600	PUSH RIVET	P3555-B	
	2-36	VY940400	CUSHION, LID	T=0.8	
	2-37	VV982000	DAMPER	1x12x12	
	2-52	VN413300	BIND HEAD BONDING B-T. SCREW	3x8 MFC2BL	
	2-54	VG893800	BIND HEAD P-TITE SCREW	2x6 MFC2BL	
	2-55	VG863900	BIND HEAD TAPPING SCREW	2.6x6 MFC2BL	
	2-56	EP630290	BIND HEAD P-TITE SCREW	3x6 MFC2BL	
	2-57	EP600250	BIND HEAD B-TITE SCREW	3x8 MFC2Y	
	2-60	VJ204800	PW HEAD S-TITE SCREW	3x6-8 MFC2BL	
* 	3-1	V7950700	P.C.B. ASS'Y	MAIN	UC
* 	3-1	V7950800	P.C.B. ASS'Y	MAIN	RTA
	3-8	MF113250	FLEXIBLE FLAT CABLE	13P 250mm	
	3-22	VV849300	SHEET	19x24	
	3-23	V5454200	DAMPER	2/10/260	
	3-25	VQ368600	PUSH RIVET	P3555-B	
*	3-27	V8152100	SHEET		
	3-31	VK173200	SCREW, TRANSISTOR	3x15 SP MFC2	
	3-33	VT669300	PW HEAD B-TITE SCREW	3x8-8 MFC2	
	3-34	VB770200	PW HEAD P-TITE SCREW	3x10-8 MFC2	
	3-35	EP630210	BIND HEAD S-TITE SCREW	3x6 MFC2BL	

\* New Parts

RX-V1200/RX-V1200RDS/HTR-5490/RX-V2200

RX-V1200/RX-V1200RDS/  
HTR-5490/RX-V2200

Ref. No.	PART NO.	Description	Remarks	Markets
* 	6	V7946200 P.C.B. ASS'Y	POWER	U
* 	6	V7946300 P.C.B. ASS'Y	POWER	C
* 	6	V7946400 P.C.B. ASS'Y	POWER	RT
* 	6	V7946500 P.C.B. ASS'Y	POWER	A
*	7	V7946700 P.C.B. ASS'Y	DSP	
*	8	V7945100 P.C.B. ASS'Y	FUNCTION	UC
*	8	V7945200 P.C.B. ASS'Y	FUNCTION	RT
*	8	V7945300 P.C.B. ASS'Y	FUNCTION	A
*	9	V7947900 P.C.B. ASS'Y	VIDEO	UC
*	9	V7948000 P.C.B. ASS'Y	VIDEO	RT
*	9	V7948100 P.C.B. ASS'Y	VIDEO	A
	11	V7424300 AM/FM TUNER	FAE350-A10F	UCRT
	11	V7424400 AM/FM TUNER	FAE404-E10F	A
* 	14	X0457A00 POWER TRANSFORMER		U
* 	14	X0458A00 POWER TRANSFORMER		C
* 	14	X0459A00 POWER TRANSFORMER		RT
* 	14	X0460A00 POWER TRANSFORMER		A
	16	V2296800 POWER CORD ASS'Y		A
	16	VZ542500 POWER CORD ASS'Y		RT
	17	V2438700 CORD STOPPER	10P1	RTA
	21	VZ625600 BINDING TIE	SE140 L=140	
	22	VV272500 DC FAN MOTOR	2410ML-05W-B20-L00	
	25	MF111100 FLEXIBLE FLAT CABLE	11P 100mm	
	27	MF115100 FLEXIBLE FLAT CABLE C&C	15P 100mm	
*	28	MF119160 FLEXIBLE FLAT CABLE	19P 160mm P=1.25	
	29	MF131100 FLEXIBLE FLAT CABLE	31P 100mm	
	31	Vi491100 FERRITE CORE	BP53RB19012080M	
*	101	V7640700 TOP COVER		GD
*	101	V7640600 TOP COVER		BL
*	103	V7618100 REAR PANEL		U
*	103	V7618200 REAR PANEL		C
*	103	V7618300 REAR PANEL		RT
*	103	V7618400 REAR PANEL		A
*	117	V7623000 BRACKET/FAN		
*	118	V7622900 DUCT/FAN		
	119	VQ775900 GROUND PLATE		
	120	V0042500 LEG	D60xH21	GD
	120	VS025000 LEG	D60xH21	BL
	132	V6068100 KNOB/D43		GD
	132	V6068000 KNOB/D43		BL
	133	V6001400 KNOB D20		GD
	133	V6001300 KNOB D20		BL
	134	V6001700 KNOB D15		GD
	134	V6001600 KNOB D15		BL
	136	VQ368600 PUSH RIVET	P3555-B	
*	142	V7796200 SHEET, WINDOW		
	143	V6002700 PLATE/SIDE L		GD
	143	V6002500 PLATE/SIDE L		BL
	144	V6003000 PLATE/SIDE R		GD
	144	V6002900 PLATE/SIDE R		BL
	148	V6742400 DAMPER	3/10/50	
	161	VN413300 BIND HEAD BONDING B-T. SCREW	3x8 MFZN2BL	
	164	VT669400 PW HEAD B-TITE SCREW	3x15-8 MFC2	

\* New Parts

Ref. No.	PART NO.	Description	Remarks	Markets
165	21991500	PW HEAD S-TITE SCREW	4x8-10 MFC2BL	BL
166	EP600250	BIND HEAD B-TITE SCREW	3x8 MFZN2Y	
167	VT669300	PW HEAD B-TITE SCREW	3x8-8 MFC2	
168	VY731200	BONDING HEAD TAPPING SCREW	3x10 MFN133	
169	VZ893000	DECORATED SCREW S-TIGHT	4x8-10 MFN133	GD
169	VK522000	DECORATED SCREW S-TIGHT	4x8-10 MFC2BL	BL
170	AA627310	GROUND TERMINAL		
171	VD069600	PW HEAD S-TITE SCREW	4x8-10 MFN133	GD
171	21991500	PW HEAD S-TITE SCREW	4x8-10 MFC2BL	BL
172	EP630210	BIND HEAD S-TITE SCREW	3x6 MFZN2BL	
173	VV220300	BIND HEAD B-TITE SCREW	3x30 MFZN2BL	
174	VB770200	PW HEAD P-TITE SCREW	3x10-8 MFC2	
175	EP600130	BIND HEAD B-TITE SCREW	3x6 MFZN2Y	
		ACCESSORIES		
* 200	V7720100	REMOTE CONTROL TRANSMITTER	RAV224	RRC4001-0001L
200-1	AAX12830	LID	103RRC-170-01R	103RRC-170-01R
201	V6267000	ANTENNA, FM	1.4m 1pc	UCRT
201	VQ147100	ANTENNA, FM	1.4m 1pc	A
202	VR248500	ANTENNA, AM LOOP	1.0m 1pc	
⚠ 203	V6545800	POWER CORD ASS'Y	INLET 2.0m	UC
	V6507100	BATTERY (MANGANESE DRY)	R6PPTT/3ST(R6P)	

\* New Parts

# Parts List for Carbon Resistors

Value	1/4W Type Part No.	1/6W Type Part No.	Value	1/4W Type Part No.	1/6W Type Part No.
1.0 Ω	HJ35 3100	HF85 3100	10 kΩ	HF45 7100	HF45 7100
1.8 Ω	HJ35 3180	*	11 kΩ	HF45 7110	HF45 7110
2.2 Ω	HJ35 3220	HF85 3220	12 kΩ	HJ35 7120	HF85 7120
3.3 Ω	HJ35 3330	HF85 3330	13 kΩ	HF45 7130	HF45 7130
4.7 Ω	HJ35 3470	HF85 3470	15 kΩ	HF45 7150	HF45 7150
5.6 Ω	HJ35 3560	HF85 3560	18 kΩ	HF45 7180	HF45 7180
10 Ω	HF45 4100	HF45 4100	22 kΩ	HF45 7220	HF45 7220
15 Ω	HJ35 4150	HF85 4150	24 kΩ	HF45 7240	HF45 7240
22 Ω	HF45 4220	HF45 4220	27 kΩ	HJ35 7270	HF85 7270
27 Ω	HJ35 4270	HF85 4270	30 kΩ	HF45 7300	HF45 7300
33 Ω	HF45 4330	HF45 4330	33 kΩ	HF45 7330	HF45 7330
39 Ω	HJ35 4470	HF85 4390	36 kΩ	HF45 7360	HF45 7360
47 Ω	HF45 4470	HF45 4470	39 kΩ	HF45 7390	HF45 7390
56 Ω	HF45 4560	HF45 4560	47 kΩ	HF45 7470	HF45 7470
68 Ω	HF45 4680	HF45 4680	51 kΩ	HF45 7510	HF45 7510
75 Ω	HF45 4750	HF45 4750	56 kΩ	HF45 7560	HF45 7560
82 Ω	HF45 4820	HF45 4820	62 kΩ	HF45 7620	HF45 7620
91 Ω	HF45 4910	HF45 4910	68 kΩ	HF45 7680	HF45 7680
100 Ω	HF45 5100	HF45 5100	82 kΩ	HF45 7820	HF45 7820
110 Ω	HJ35 5110	HF85 5110	91 kΩ	HF45 7910	HF45 7910
120 Ω	HF45 5120	HF45 5120	100 kΩ	HF45 8100	HF45 8100
150 Ω	HF45 5150	HF45 5150	110 kΩ	HF45 8110	HF45 8110
160 Ω	HJ35 5160	*	120 kΩ	HF45 8120	HF45 8120
180 Ω	HF45 5180	HF45 5180	150 kΩ	HF45 8150	HF45 8150
200 Ω	HF45 5200	HF45 5200	180 kΩ	HF45 8180	HF45 8180
220 Ω	HF45 5220	HF45 5220	220 kΩ	HJ35 8220	HF85 8220
270 Ω	HF45 5270	HF45 5270	270 kΩ	HF45 8270	HF45 8270
330 Ω	HF45 5330	HF45 5330	300 kΩ	HF45 8300	HF45 8300
390 Ω	HF45 5390	HF45 5390	330 kΩ	HF45 8330	HF45 8330
430 Ω	HF45 5430	HF45 5430	390 kΩ	HJ35 8390	HF85 8390
470 Ω	HF45 5470	HF45 5470	470 kΩ	HF45 8470	HF45 8470
510 Ω	HF45 5510	HF45 5510	560 kΩ	HJ35 8560	HF85 8560
560 Ω	HF45 5560	HF45 5560	680 kΩ	HJ35 8680	HF85 8680
680 Ω	HF45 5680	HF45 5680	820 kΩ	HJ35 8820	HF85 8820
820 Ω	HF45 5820	HF45 5820	1.0 MΩ	HF45 9100	HF45 9100
910 Ω	HF45 5910	HF45 5910	1.2 MΩ	HJ35 9120	*
1.0 kΩ	HF45 6100	HF45 6100	1.5 MΩ	HJ35 9150	HF85 9150
1.2 kΩ	HF45 6120	HF45 6120	1.8 MΩ	HJ35 9180	HF85 9180
1.5 kΩ	HF45 6150	HF45 6150	2.2 MΩ	HJ35 9220	HF85 9220
1.8 kΩ	HF45 6180	HF45 6180	3.3 MΩ	HJ35 9330	HF85 9330
2.0 kΩ	HJ35 6200	HF85 6200	3.9 MΩ	HJ35 9390	*
2.2 kΩ	HF45 6220	HF45 6220	4.7 MΩ	HJ35 9470	HF85 9470
2.4 kΩ	HJ35 6240	HF85 6240			
2.7 kΩ	HF45 6270	HF45 6270			
3.0 kΩ	HF45 6300	HF45 6300			
3.3 kΩ	HF45 6330	HF45 6330			
3.6 kΩ	HJ35 6360	HF85 6360			
3.9 kΩ	HF45 6390	HF45 6390			
4.7 kΩ	HF45 6470	HF45 6470			
5.1 kΩ	HF45 6510	HF45 6510			
5.6 kΩ	HF45 6560	HF45 6560			
6.8 kΩ	HF45 6680	HF45 6680			
8.2 kΩ	HF45 6820	HF45 6820			
9.1 kΩ	HF45 6910	HF45 6910			

**1/4W Type**

HJ35 ○○○○

10mm

**1/4W Type**

HF45 ○○○○

5mm

**1/6W Type**

HF85 ○○○○

5mm

# RX-V1200/RX-V1200RDS/HTR-5490 REMOTE CONTROL TRANSMITTER

## SCHEMATIC DIAGRAM

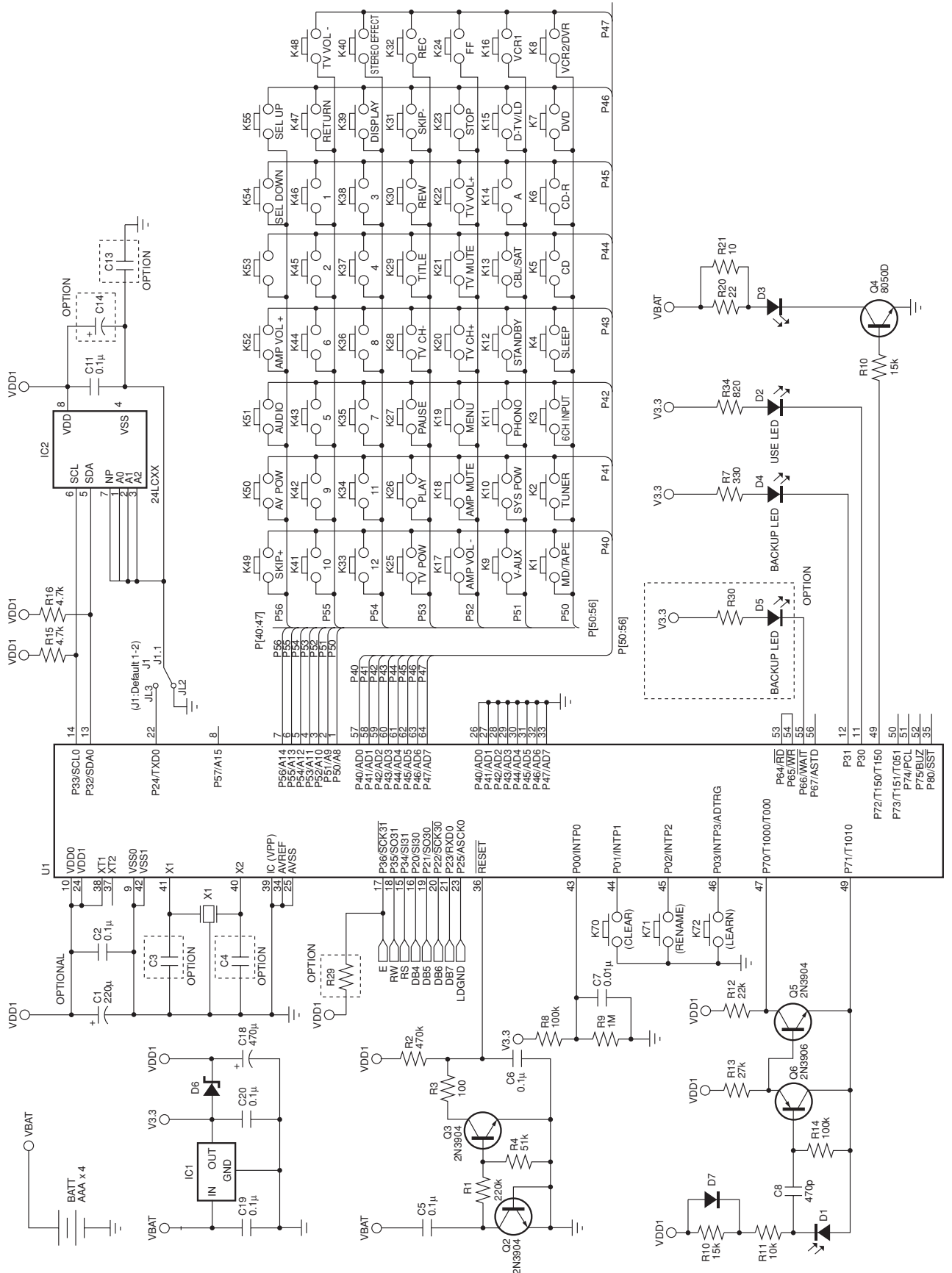

RX-V1200/RX-V1200RDS/  
HTR-5490/RX-V2200

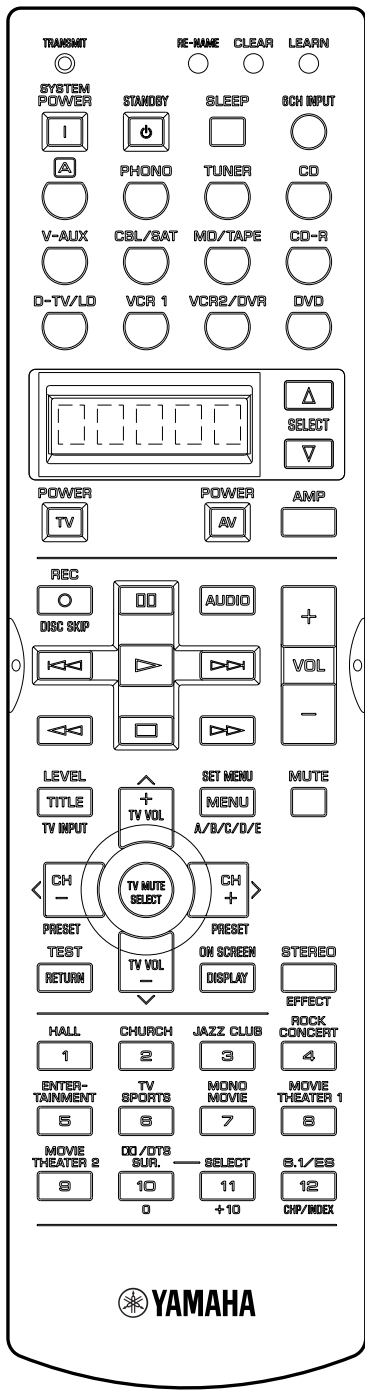

Key No.	Function	Default Code	Schematic Key No.
4	SYSTEM POWER	7A-1D	K10
5	STANDBY	7A-1E	K12
6	SLEEP	7A-57	K4
7	6CH INPUT	7A-87	K3
8		-	K14
9	PHONO	7A-14	K11
10	TUNER	7A-16	K2
11	CD	7A-15	K5
12	V-AUX	7A-55	K9
13	CBL/SAT	7A-C0	K13
14	MD/TAPE	7A-18	K1
15	CD-R	7A-19	K6
16	D-TV/LD	7A-54	K15
17	VCR 1	7A-0F	K16
18	VCR2/DVR	7A-13	K8
19	DVD	7A-C1	K7
20		-	K55
21		-	K54
22	POWER [TV]	-	K25
23	POWER [AV]	7C-80	K50
25	REC [O]	7C-8B	K32
26		7C-83	K27
27	AUDIO	7C-AD	K51
28		7C-B9	K31
29		7C-82	K26
30		7C-BA	K49
31		7C-86	K30
32		7C-85	K23
33		7C-87	K24
34	VOL +	7A-1A	K52
35	VOL -	7A-1B	K17
36	LEVEL [TITLE]	7C-B1	K29
37	TV VOL +	7C-B4	K22
38	SET MENU [MENU]	7C-B2	K19
39	CH -	7C-B5	K28
40	TV MUTE SELECT	7C-B8	K21
41	CH +	7C-B6	K20
42	MUTE	7A-1C	K18
43	TEST [RETURN]	7C-B7	K47
44	TV VOL -	7C-B3	K48
45	ON SCREEN [DISPLAY]	7C-A6	K39
46	STEREO	7A-56	K40
47	1	7C-94	K46
48	2	7C-95	K45
49	3	7C-96	K38
50	4	7C-97	K37
51	5	7C-98	K43
52	6	7C-99	K44
53	7	7C-9A	K35
54	8	7C-9B	K36
55	9	7C-9C	K42
56	10	7C-93	K41
57	11	7C-9D	K34
58	12	7C-9E	K33



# RX-V2200 REMOTE CONTROL TRANSMITTER

## SCHEMATIC DIAGRAM

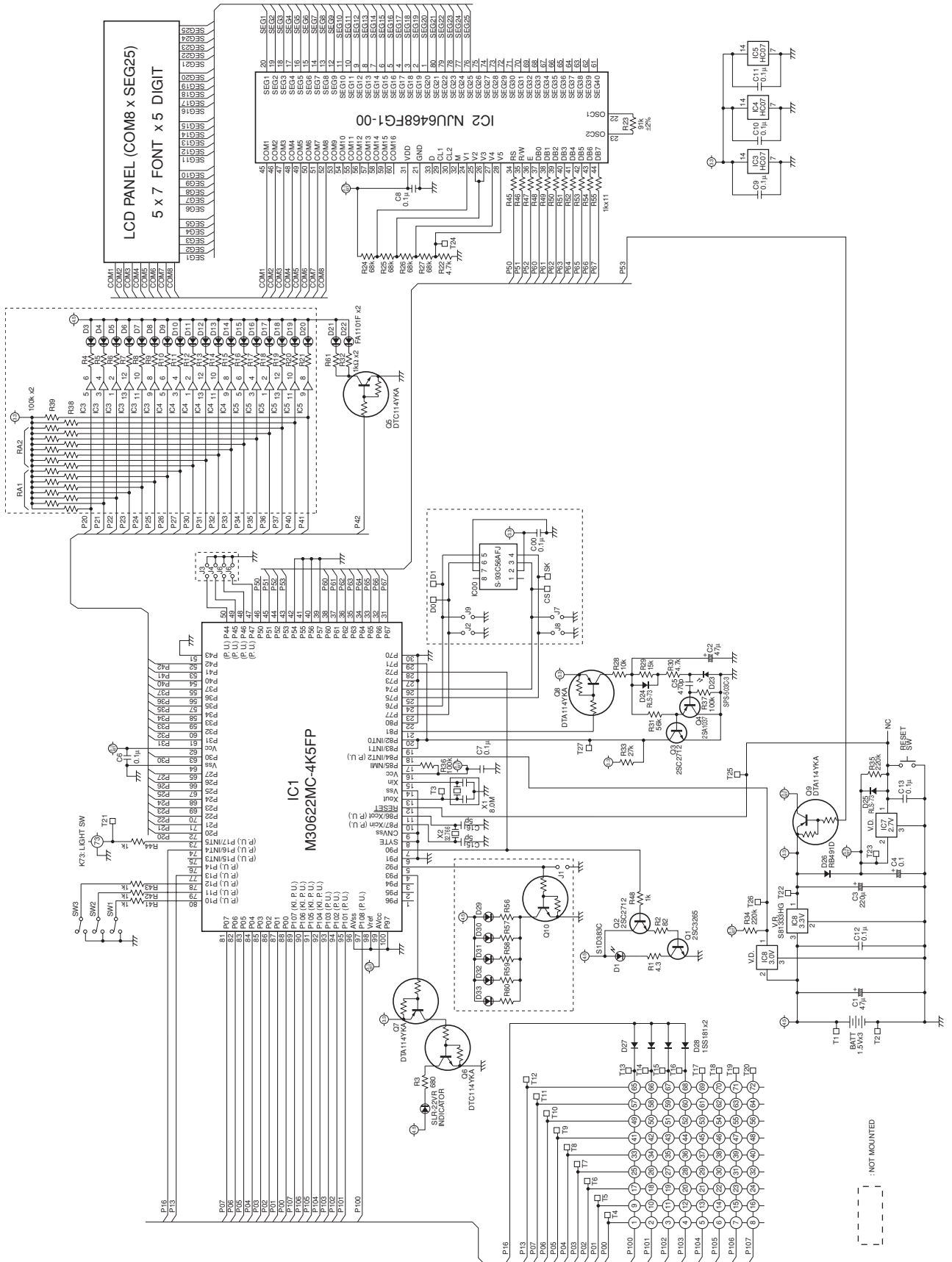

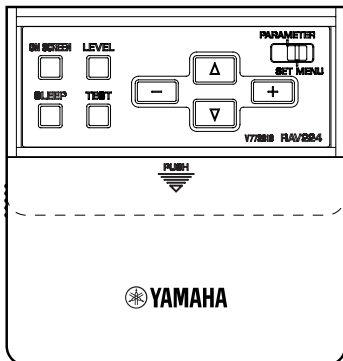
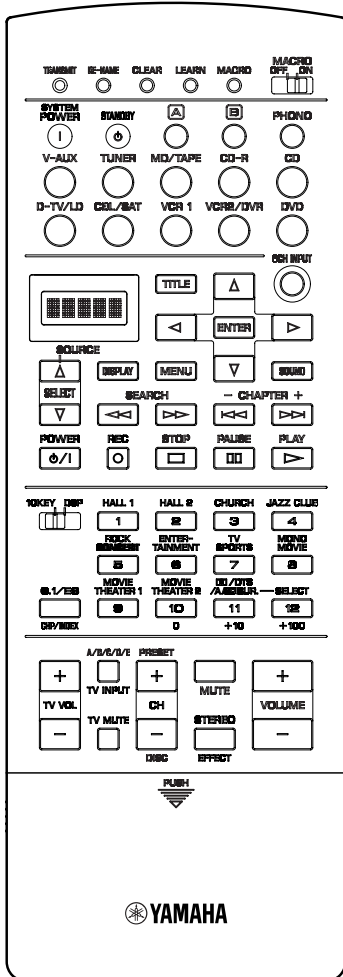

Initial Code

Key No.	Key Name	YPC	DSP *1	Zone2 *2
1	—	—	—	—
2	RE-NAME	—	—	—
3	CLEAR	—	—	—
4	LEARN	—	—	—
5	MACRO	—	—	—
6	POWER on	*7A-1D	7D-90	*7A-1D
7	STANDBY	7A-1E	7D-91	7A-1E
8	A	—	—	—
9	B	—	—	—
10	PHONO	7A-14	7D-88	7A-D0
11	V-AUX	7A-55	7D-8A	7A-D8
12	TUNER	7A-16	7D-89	7A-D2
13	MD/TAPE	7A-18	7D-8B	7A-D3
14	CD-R	7A-19	7D-99	7A-D4
15	CD	7A-15	7D-87	7A-D1
16	D-TV/LD	7A-54	7D-84	7A-D9
17	CBL/SAT	7A-13	7D-82	7A-CC
18	VCR1	7A-0F	7D-81	7A-D6
19	VCR2/DVR	7A-13	7D-82	7A-D7
20	DVD	7A-C1	7D-97	7A-CD
21	EXT. DEC.	7A-87	7D-8C	7A-87

\*1: These code are transmitted when "DSP" is set-up as AMP library.  
 \*2: These code are transmitted when "ZONE2" is chosen with Select key.  
 CAUTION) This is displayed as a possible selection when the AMP library is set in ZONE 2.  
 \*; Transmitting Code of K6, "7A-1D"  
 Full word transmitted twice.  
 Any device not listed on this table has no initial code.

\*1: AMPライブラリーをDSPに設定することで送信されます。  
 \*2: SelectキーによりZONE2を選択することで送信されます。  
 注意) AMPライブラリーをZONE2に設定した場合に選択肢として表示されます。  
 \*; K6送信コード"7A-1D"について  
 ワード部が2回送信されます。  
 本表に記載なきデバイスの初期コードはありません。

Key No.	Key Name	Device								
		DVD (K20)	CD-R (K14)	CD (K15)	MD/TAPE (K13)	TUNER (K12)	A (K8)			
22	Up	→	→	→	7C-B4	—	—	—	—	
23	TITLE	→	→	→	7C-B1	—	—	—	—	
24	Left	→	→	→	7C-B5	—	—	—	—	
25	ENTER	→	→	→	7C-B8	—	—	—	—	
26	Right	→	→	→	7C-B6	—	—	—	—	
27	SOUND	→	→	→	7C-AD	—	—	—	7C-12	
28	Down	→	→	→	7C-B3	—	—	—	—	
29	MENU	→	→	→	7C-B2	—	—	—	—	
30	DISPLAY	→	→	→	7C-A6	7F-9E	79-0A	79-A5	—	7C-13
31	REW	→	→	→	7C-86	7F-88	7A-0D	79-AC	—	7C-06
32	FF	→	→	→	7C-87	7F-89	7A-0C	79-AD	—	7C-07
33	CHP/SKIP -	→	→	→	7C-89	7F-86	7A-0B	79-AB	—	7C-02
34	CHP/SKIP +	→	→	→	7C-BA	7F-87	7A-0A	79-AE	—	7C-03
35	PLAY	→	→	→	7C-82	7F-82	7A-08	79-A8	—	7C-05
36	PAUSE	→	→	→	7C-83	7F-83	7A-09	79-A9	—	7C-5A
37	STOP	→	→	→	7C-85	7F-84	7A-09	79-AA	—	7C-5B
38	REC	→	→	→	7C-B7	—	—	79-AF	—	—
39	POWER	→	→	→	—	—	—	—	—	—
40	SELECT down	—	—	—	—	—	—	—	—	—
41	SELECT up	—	—	—	—	—	—	—	—	—
		SW2	DSP			10 key				
42	PRG1	7A-88	7D-D0	7A-88	7C-94	7F-91	79-11	79-85	7A-E5	7C-17
43	PRG2	7A-89	7D-D1	7A-89	7C-95	7F-92	79-12	79-86	7A-E6	7C-18
44	PRG3	7A-8A	7D-D2	7A-8A	7C-96	7F-93	79-13	79-87	7A-E7	7C-19
45	PRG4	7A-8B	7D-D3	7A-8B	7C-97	7F-94	79-14	79-88	7A-E8	7C-1A
46	PRG5	7A-8C	7D-D4	7A-8C	7C-98	7F-95	79-15	79-89	7A-E9	7C-1B
47	PRG6	7A-8D	7D-D5	7A-8D	7C-99	7F-96	79-16	79-8A	7A-EA	7C-1C
48	PRG7	7A-8E	7D-D6	7A-8E	7C-9A	7F-97	79-17	79-8B	7A-EB	7C-1D
49	PRG8	7A-8F	7D-D7	7A-8F	7C-9B	7F-98	79-18	79-8C	7A-EC	7C-1E
50	PRG9	7A-90	7D-D8	7A-90	7C-9C	7F-99	79-19	79-8D	7A-E1	7C-1F
51	PRG10	7A-91	7D-D9	7A-91	7C-93	7F-90	79-10	79-8E	7A-E2	7C-16
52	PRG11	7A-92	7D-DA	7A-92	7C-9D	7F-9A	79-1A	79-8F	7A-E3	7C-5D
53	PRG12	7A-93	7D-DB	7A-96	7C-9F	7F-8C	79-0D	—	7A-E4	7C-5E
54	6.1/ES	7A-97	7D-DF	7A-97	7C-9E	7F-8A	79-0B	—	7A-E0	7C-15
55	TV VOL up	→	→	→	—	—	—	—	—	—
56	TV VOL down	→	→	→	—	—	—	—	—	—
57	TV INPUT	→	→	→	—	—	—	—	7A-12	—
58	TV MUTE	→	→	→	—	—	—	—	—	—
59	CH up	→	→	→	7C-8B	—	7A-4F	—	7A-10	—
60	CH down	→	→	→	7C-8A	—	7A-50	—	7A-11	—
61	MUTE	7A-1C	7D-94	7A-DC	—	—	—	—	—	—
62	EFFECT	7A-56	7D-C1	7A-56	—	—	—	—	—	—
63	VOLUME up	7A-1A	7D-8D	7A-DA	—	—	—	—	—	—
64	VOLUME down	7A-1B	7D-8E	7A-DB	—	—	—	—	—	—
		SW3	Parameter	Set Menu	Parameter	Set Menu	Parameter	Set Menu		
65	ON SCREEN	7A-C2	7D-C2	7A-C2	—	—	—	—	—	—
66	SLEEP	7A-57	7D-93	7A-57	—	—	—	—	—	—
67	LEVEL	7A-86	7D-95	7A-86	—	—	—	—	—	—
68	TEST	7A-85	7D-CA	7A-85	—	—	—	—	—	—
69	LEFT	7A-C7	7A-9F	7D-C7	7D-9F	7A-C7	7A-9F	—	—	—
70	UP	7A-C5	7A-9D	7D-C5	7D-9D	7A-C5	7A-9D	—	—	—
71	DOWN	7A-C4	7A-9C	7D-C4	7D-9C	7A-C4	7A-9C	—	—	—
72	RIGHT	7A-C6	7A-9E	7D-C6	7D-9E	7A-C6	7A-9E	—	—	—

Initial Macro setup

Key No.	Key Name	1	2	3	4-10
6	POWER on	K6	K39 TV	—	—
7	STANDBY	K7	—	—	—
8	A	K6	K8	—	—
9	B	K6	K9	—	—
10	PHONO	K6	K10	—	—
11	V-AUX	K6	K11	—	—
12	TUNER	K6	K12	—	—
13	MD/TAPE	K6	K13	K35	MD
14	CD-R	K6	K14	K35	CD-R
15	CD	K6	K15	K35	CD
16	D-TV/LD	K6	K16	—	—
17	CBL/SAT	K6	K17	—	—
18	VCR1	K6	K18	K35	VCR1
19	VCR2/DVR	K6	K19	K35	VCR2
20	DVD	K6	K20	K35	DVD