

D

1k 50 ma T

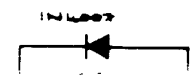

000

1960 BOARD 7

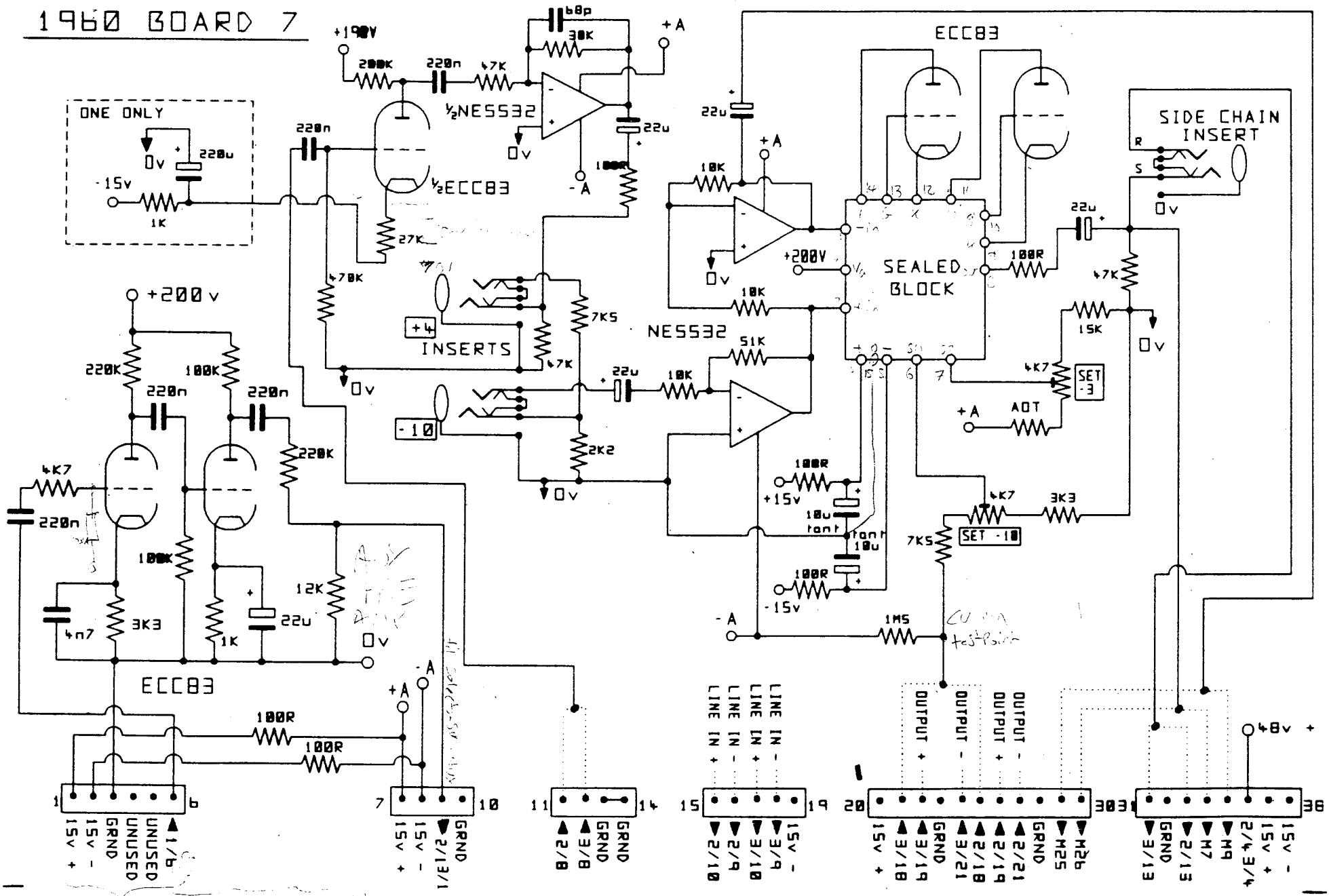

1960 BOARD No.2 (3) {complete}

Note: Figures in parentheses are for BOARD 3. MOLEX viewed from MIC Input

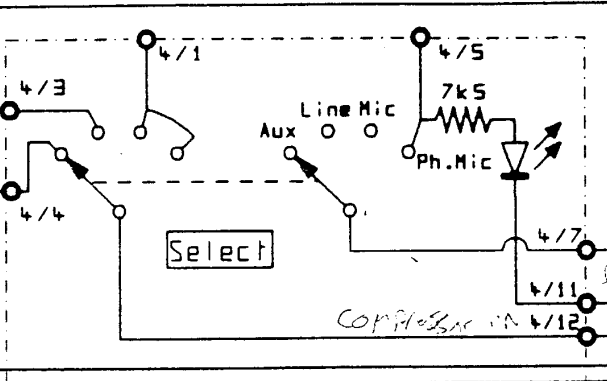
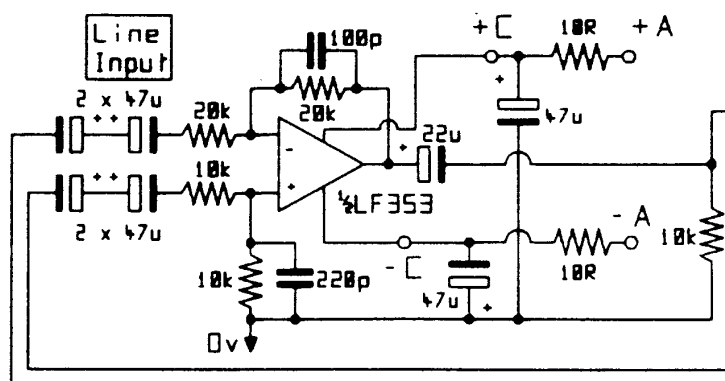

- 7/9 GRND
- UNUSED
- 7/3b {48V}
- UNUSED
- UNUSED
- Ph.Mic GRND
- 7/11 (7/12)

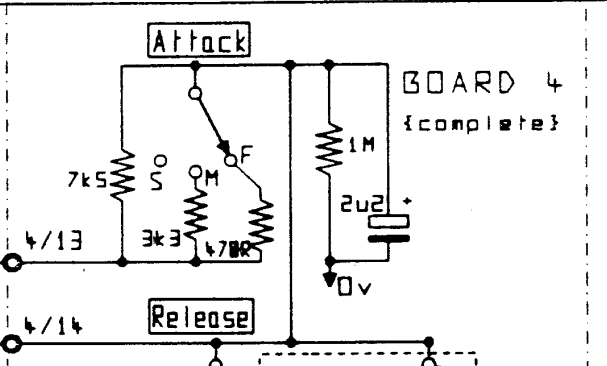
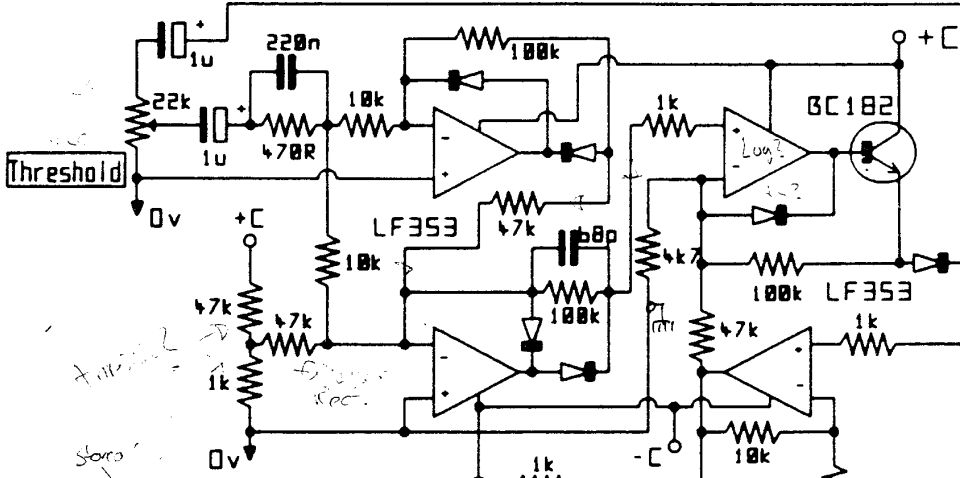

- 9 + LINE IN
- 12 - LINE IN
- UNUSED
- UNUSED

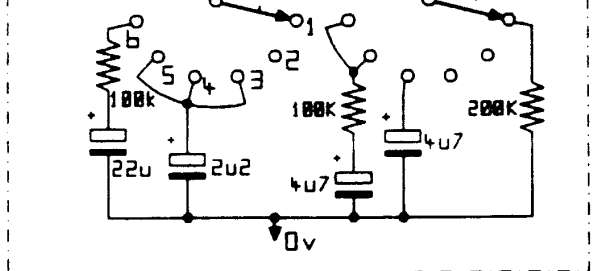
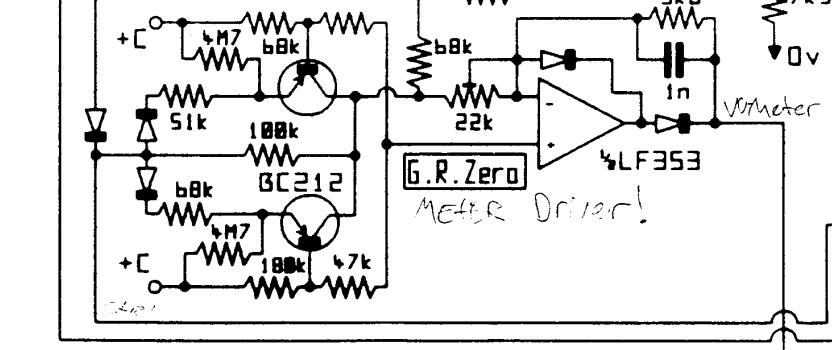

- 13 VCA out
- 13b -A
- 15v -
- 15v +
- 16b UNUSED

- 17 M17 (M18)
- 7/25 (7/21)
- 7/2b (7/22)
- GRND
- 7/27 (7/24)
- 21

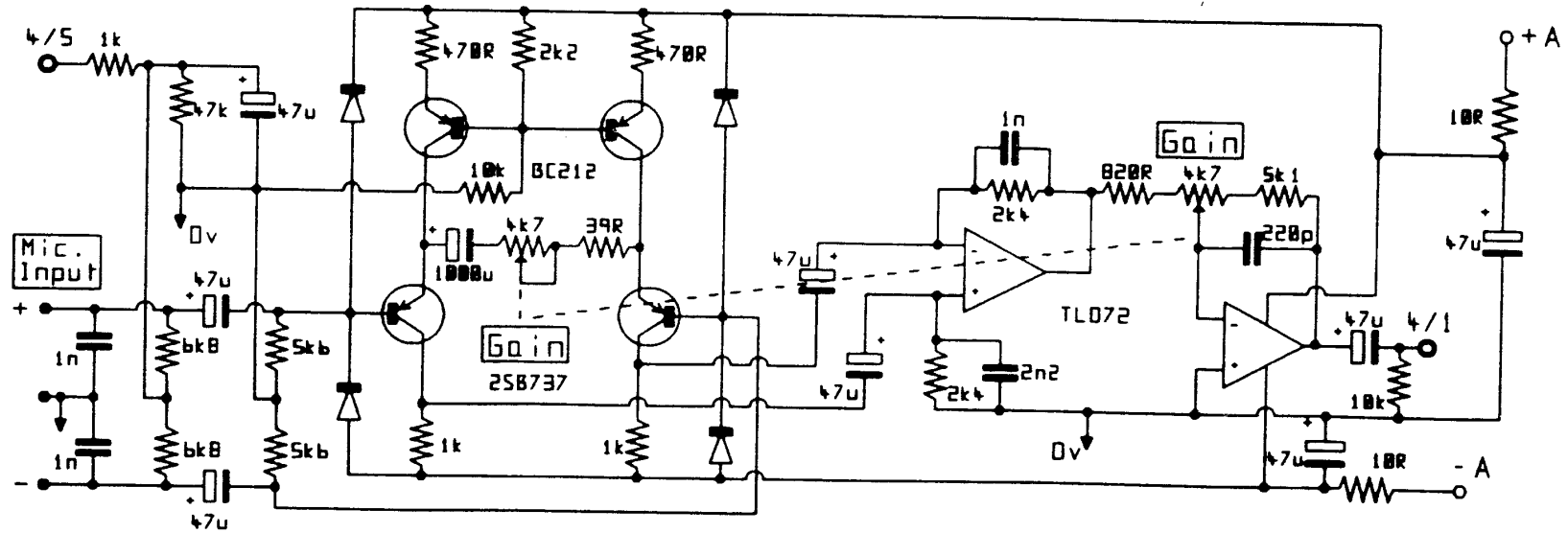
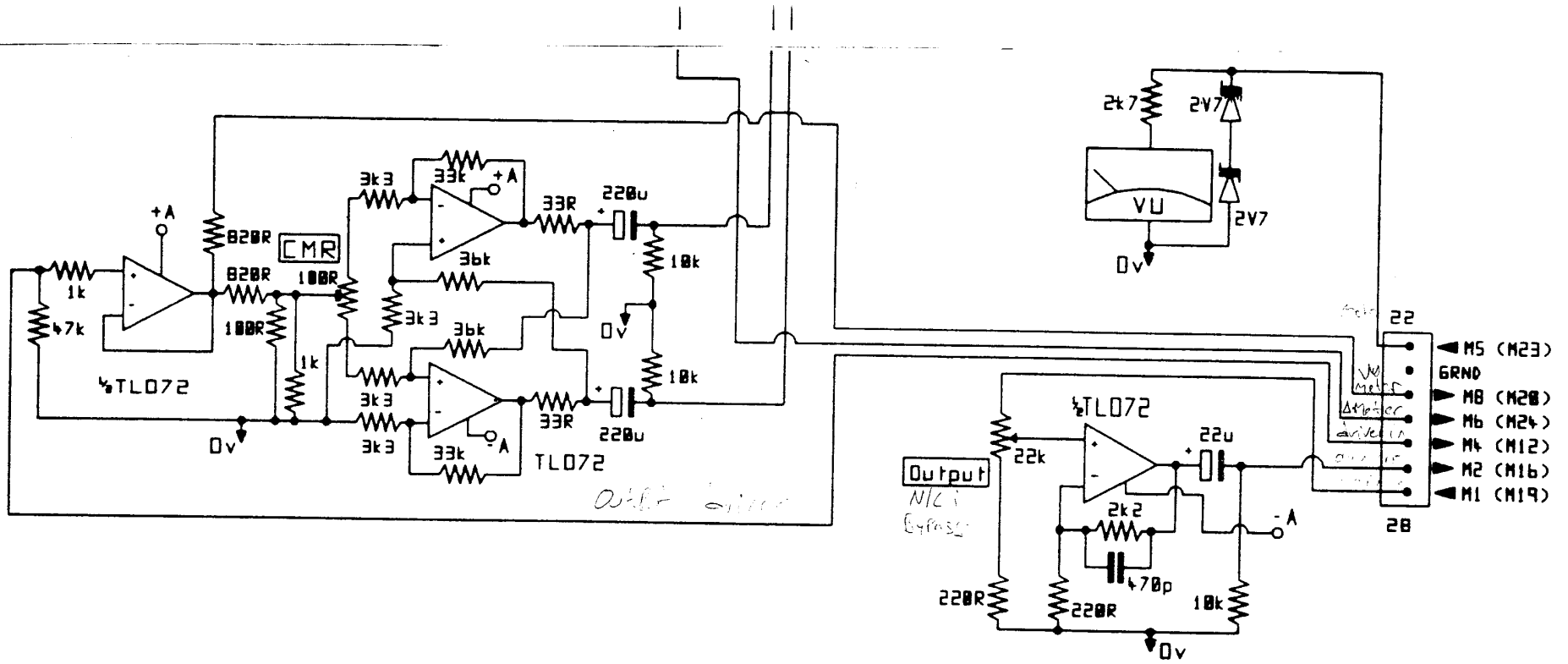

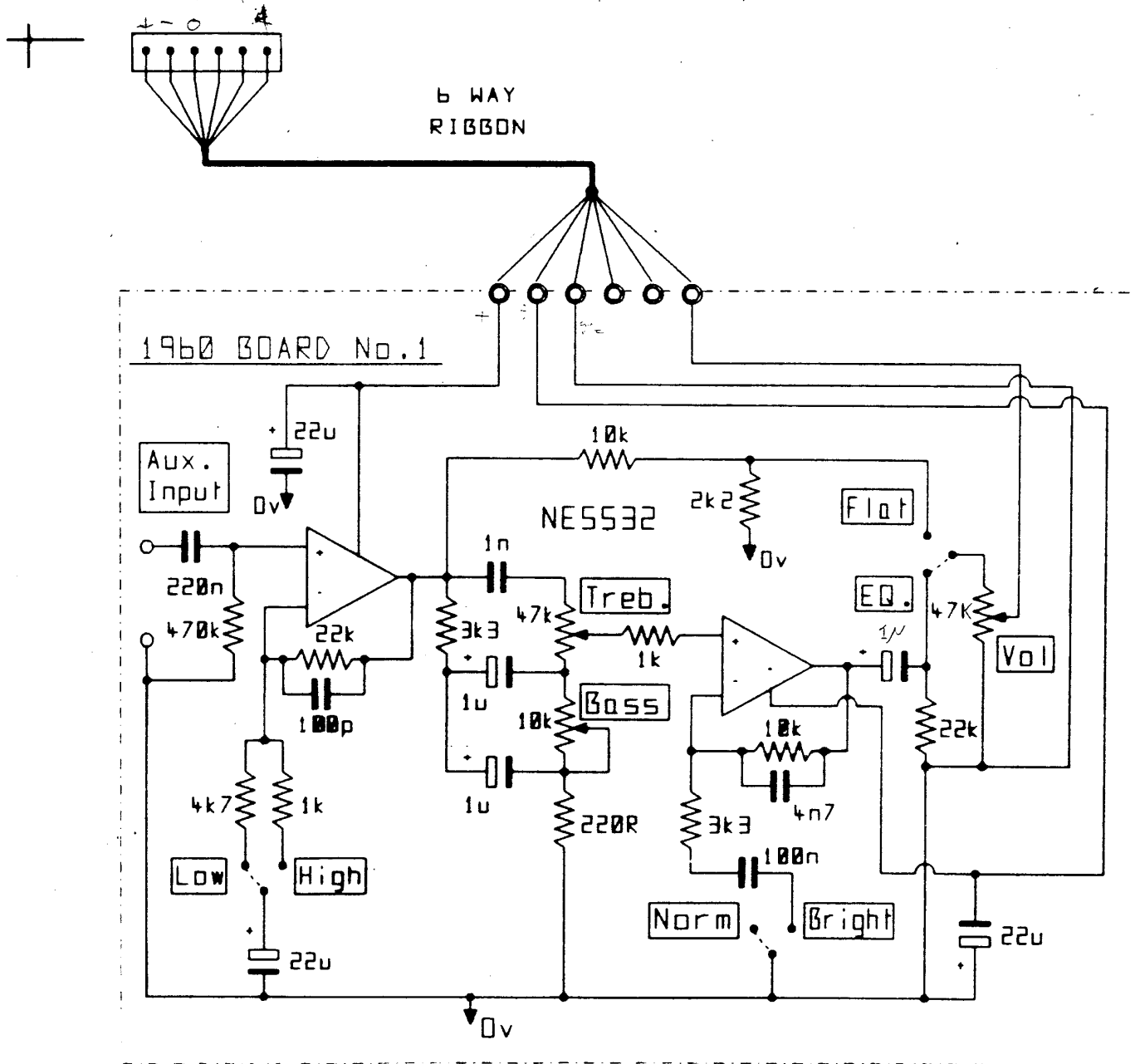

Output, V.U./G.R. Switching., Stereo Linking., Ribbon Cable Connector.

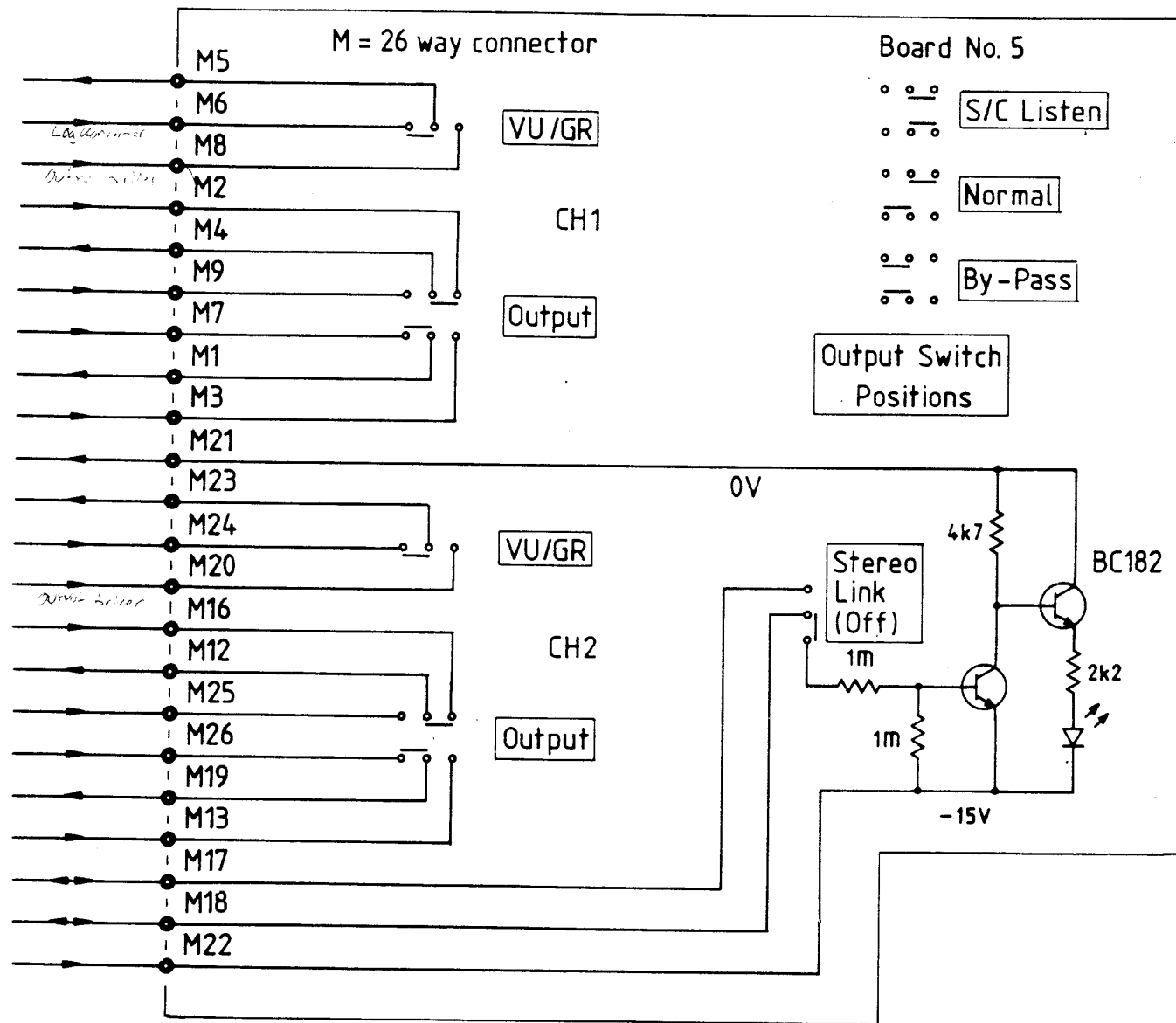

TO OTHER CHANNEL
SIDE CHAIN

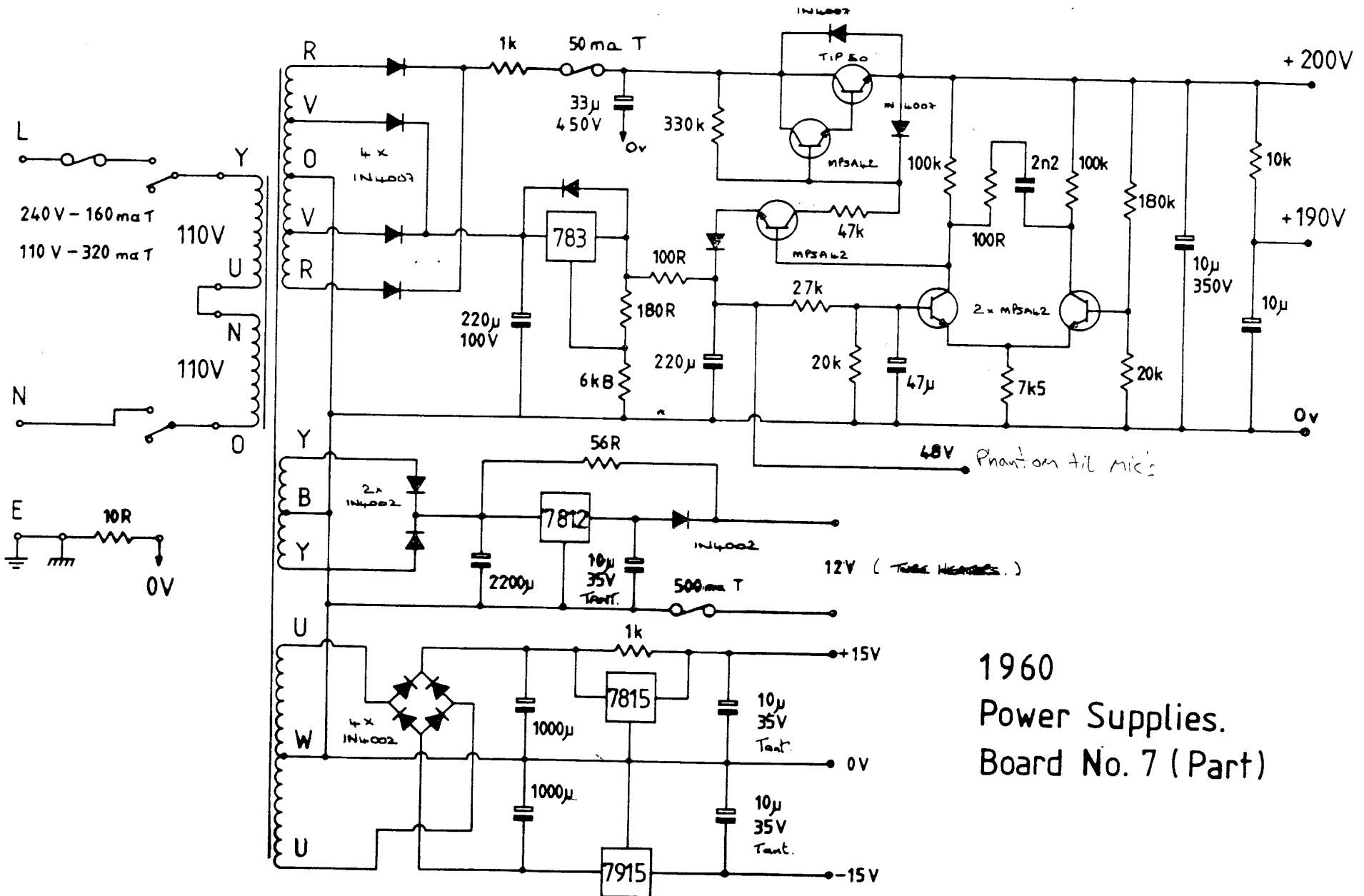

1960
Power Supplies.
Board No. 7 (Part)

- 1: inverting input
- 2: +200V (Va)
- 3: noninverting input
- 4: +15V stab.
- 5: -15V stab.
- 6: CTRL = 10db gain set
- 7: -3db gain set
- 8: output = 3db?
- 9: K_1
- 10: g_1
- 11: A_1
- 12: K_2
- 13: g_2
- 14: A_2
- 15: output

$U_{ctrl} = 2.2V = \pm 3db \text{ gain}$
 $V_{ctrl} = 3.3V = \pm 10db \text{ gain}$

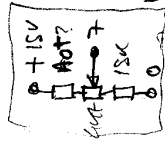
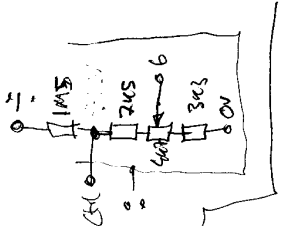

$V_{set} =$
 $V_{ctrl \text{ set}} =$

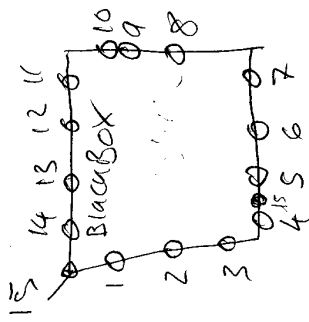

DRAWMER VACUUM TUBE COMPRESSOR AMPLIFIER 1960

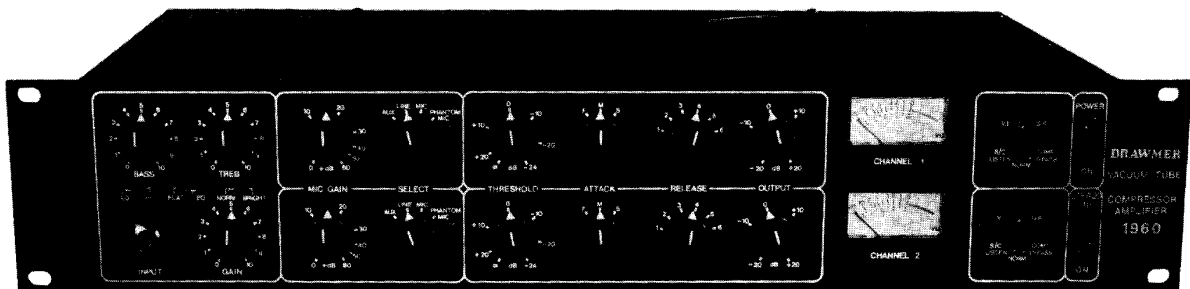

THERE IS LITTLE DOUBT IN THE MINDS OF MANY ENGINEERS AND MUSICIANS, THAT VACUUM TUBES POSSESS A UNIQUE SOUND QUALITY AND THERE IS SOME TECHNICAL EVIDENCE TO SUPPORT THIS BELIEF. SUCH EQUIPMENT IS SAID TO HAVE A "WARMER", MORE "ALIVE" SOUND.

The DRAWMER 1960 is a dual compressor amplifier, using vacuum tubes in conjunction with semiconductors, to provide a compact unit with additional capabilities.

Each channel comprises a tube compressor and pre-amplifier, feeding an electronically balanced output stage, giving a maximum output level of + 26dBm. The compressor has a soft knee characteristic with variable threshold and switchable attack and release. An output level control provides gain make-up of upto 20dB.

In addition to a balanced line input, a low noise microphone input is provided with variable gain from 0 to 60dB. Phantom power is available if required, with a LED showing phantom power on.

A single auxiliary input on the front panel gives direct access for guitar or any other instrument. Equalisation is provided, along with sufficient gain to overload the tube preamp for sustain effects.

An insert point at the rear of each channel allows additional effects to be added before compression so that when using the mic preamp, equalisation may be used or flanging may be added when using guitar with the auxiliary input.

A second insert point provides for side chain equalisation should it be required. E.Q. applied in this way may be monitored via a "side chain listen" facility.

Analogue meters indicate signal levels or gain reduction.

Stereo linking is accomplished by means of a front panel switch with a LED showing linking in operation.

Signal access is via XLR connectors at the rear whilst inserts are un-balanced stereo jack (ring - send, tip - return).