

EQF-2

PARAMETRIC EQUALIZER/FILTER

REV.

D 1-16-81
3/31
D 1-84



- Tunable Peak/Shelf EQ
- Tunable Hi/Lo Pass Filter
- Modular (Retrofits to Industry Standards)
- Full Band (20Hz to 20kHz)
- Constant Bandwidth (1.5 Octave)
- Reciprocal Equalization Curves (Cut/Boost)
- Resolution (Expanded 600° Cut/Boost)

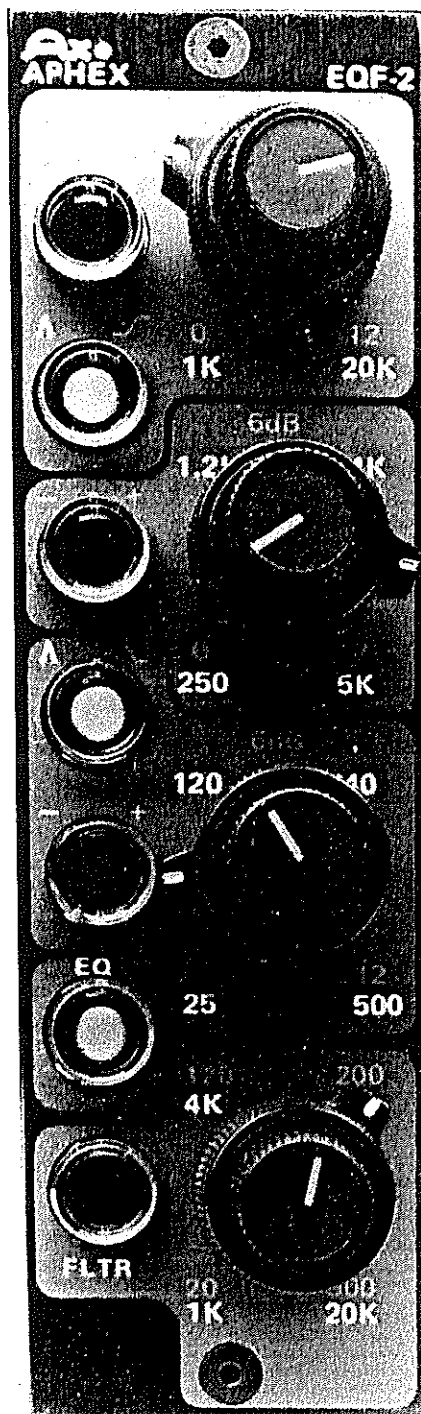

Patents Pending

Well established in major studios internationally, the EQF-2 is available through the worldwide sales offices of Aphe Systems Ltd.

To fix that difficult guitar or that impossible bass drum, or simply to get that "just right" sound, the EQF-2 has proven itself to be a powerful and creative tool.

The design engineers at Aphe are also experienced musicians and studio personnel, and they *listen to what they design*. One cannot determine what a piece of gear sounds like by looking at a graph. The EQF-2's curves were chosen for the way they *sounded* not how they *looked*. The "music first" philosophy carries through all Aphe products, because good music is what it's all about in the first place.



SPECIFICATIONS

INPUT SPECIFICATIONS:

HIGH LEVEL INPUT Z = 34K OHM; MAXIMUM INPUT LEVEL = +30dBm
 LOW LEVEL INPUT Z = 11K OHM; MAXIMUM INPUT LEVEL = +20dBm

OUTPUT SPECIFICATIONS:

HIGH LEVEL OUTPUT AT CLIPPING = +30dBm
 LOW LEVEL OUTPUT AT CLIPPING = +20dBm
 NOISE OUTPUT (INPUT SHORTED):
 HIGH LEVEL OUT = -93dBm
 LOW LEVEL OUT = -103dBm

TRANSFORMER (OUTPUT):

#JE 123 AL (OPTIONAL)

(OUTPUT SPECIFICATIONS WITH BIPOLAR 16 VOLT SUPPLY.)

FREQUENCY RESPONSE:

EQUALIZERS AND FILTERS OUT OF CIRCUIT: ±0.1 dB, 10 TO 20,000 HZ.

EQUALIZERS AND FILTERS IN CIRCUIT, MINIMUM EQUALIZATION, MAXIMUM BANDWIDTH: -1 dB, 20 TO 20,000 HZ.

FILTER AND EQUALIZER CHARACTERISTICS:

HIGH PASS TUNING (2ND ORDER BUTTERWORTH): = 20 TO 500 HZ FLAT PASSBAND.

LOW PASS TUNING (2ND ORDER BUTTERWORTH) 1 TO 20 KHZ FLAT PASSBAND.

LOW FREQUENCY EQUALIZER: 25 HZ TO 500 Hz ±12dB (PEAKING & SHELIVING)

MID FREQUENCY EQUALIZER: 250 TO 5,000 Hz ±12dB

HIGH FREQUENCY EQUALIZER: 1 KHZ TO 20 KHZ ±12dB (PEAKING & SHELIVING)

TRUE RECIPROCAL BOOST/CUT SWITCHING ON ALL THREE EQ RANGES.

SEPARATE EQUALIZER AND FILTER IN/OUT SWITCHING.

DISTORTION AND TRANSIENT RESPONSE:

HARMONIC AND I.M. DISTORTION ARE LESS THAN 0.1%

SLEW RATE: GREATER THAN 10 VOLTS PER MICROSECOND.

OVERSHOOT AND RINGING: NEGLIGIBLE, WITH OR WITHOUT LOADING

MECHANICAL DATA:

THE EQF-2 IS AN ELECTRO-MECHANICAL RETROFIT FOR AENGUS, APSI, AUTOMATED PROCESSES, MODULAR AUDIO PRODUCTS, AND MELCOR EQUALIZERS.

FRONT PANEL: 5.25 IN × 1.5 IN. (13.3 CM. × 3.8 CM.)

DEPTH: 6 IN. (15.2 CM.)

WEIGHT: 2 LB. (0.9 KG.)

POWER REQUIREMENTS:

±12 VOLTS TO ±18 VOLTS AT 75MA MAXIMUM CURRENT AND 1% OR BETTER RIPPLE.

EDGE CONNECTOR:

15 PIN, 4MM SPACING

- | | |
|-----------------------|--------------------------|
| 1 = CHASSIS GND | 9 = LOW LEVEL INPUT |
| 2 = HIGH LEVEL OUTPUT | 10 = HIGH LEVEL INPUT |
| 3 = LOW LEVEL OUTPUT | 11 = GAIN TRIM |
| 4 = OUTPUT LOW SIDE | 12 = POWER IN |
| 5 = POWER COMMON | 13 = POWER SUPPLY COMMON |
| 6 = SPARE | 14 = POWER IN |
| 7 = SPARE | 15 = SPARE |
| 8 = INPUT LOW SIDE | |

*GAIN ADJUSTMENT IS ACCOMPLISHED BY RESISTOR TO POWER COMMON. GAIN INCREASES AS FOLLOWS:
 4.7K = +2 dB, 1.6 K = +4 dB,
 0.62K = +6dB, 0.1K = +8 dB

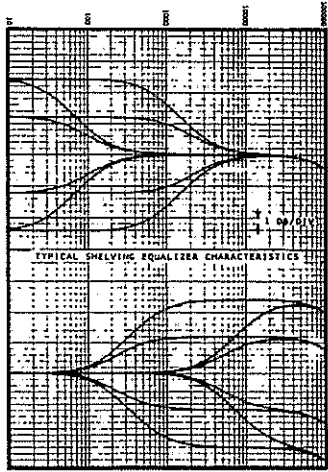
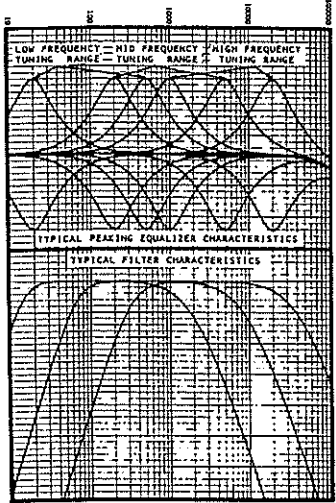

EQF-2 BLOCK DIAGRAM

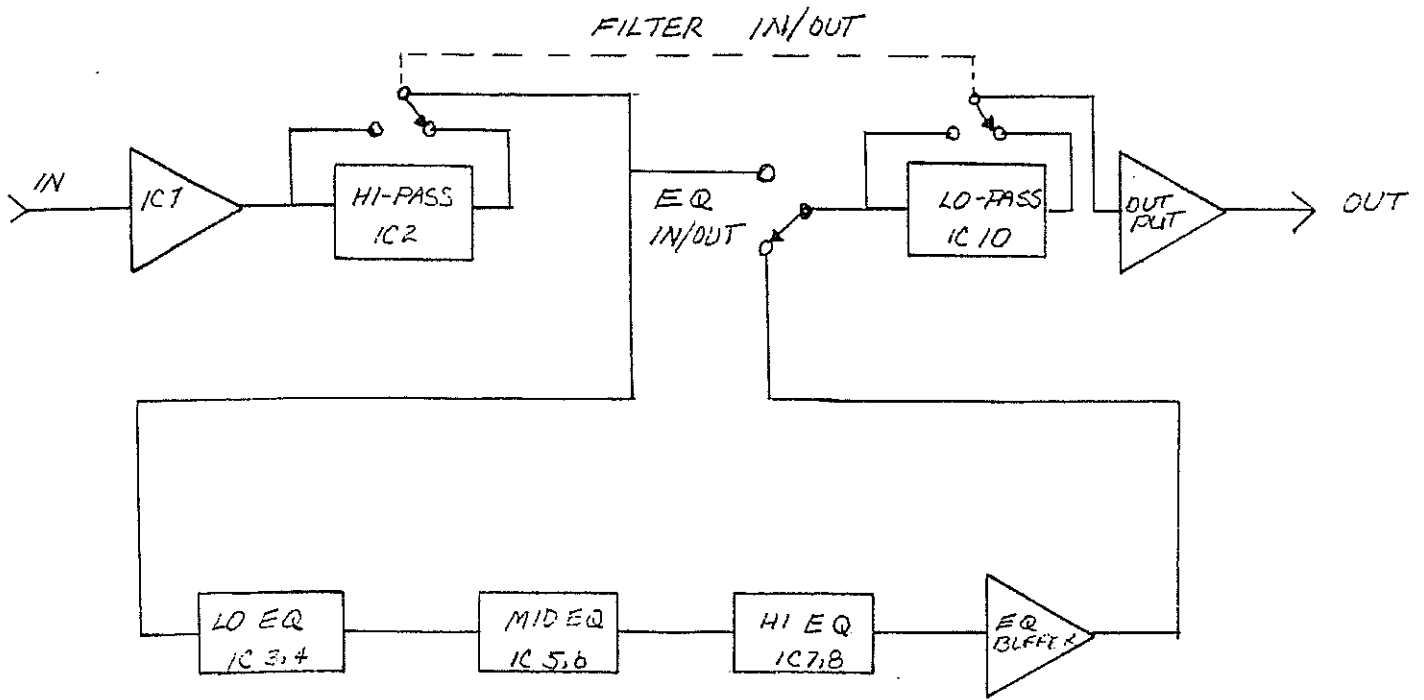

EQ-F 2 SIGNAL PATH

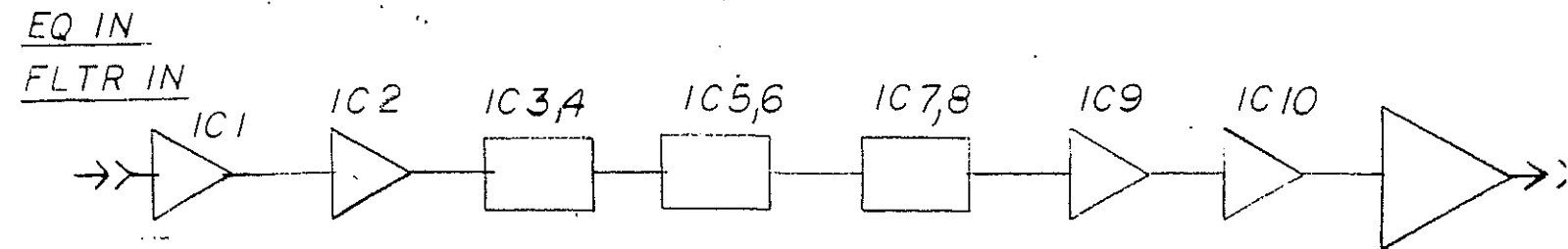
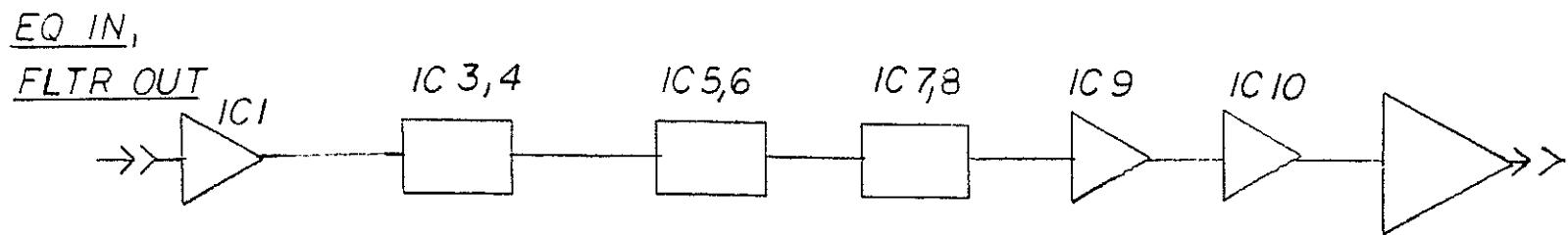
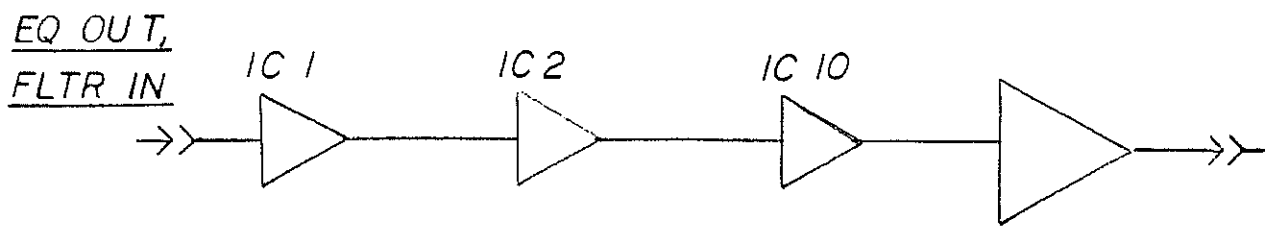
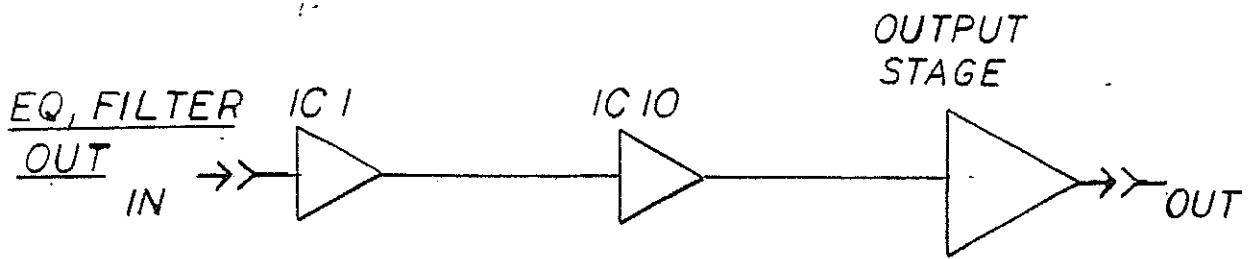

EQF-2
HI PASS

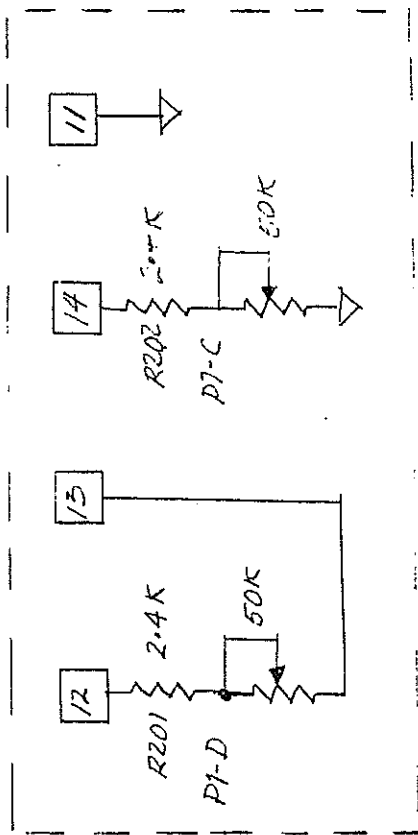
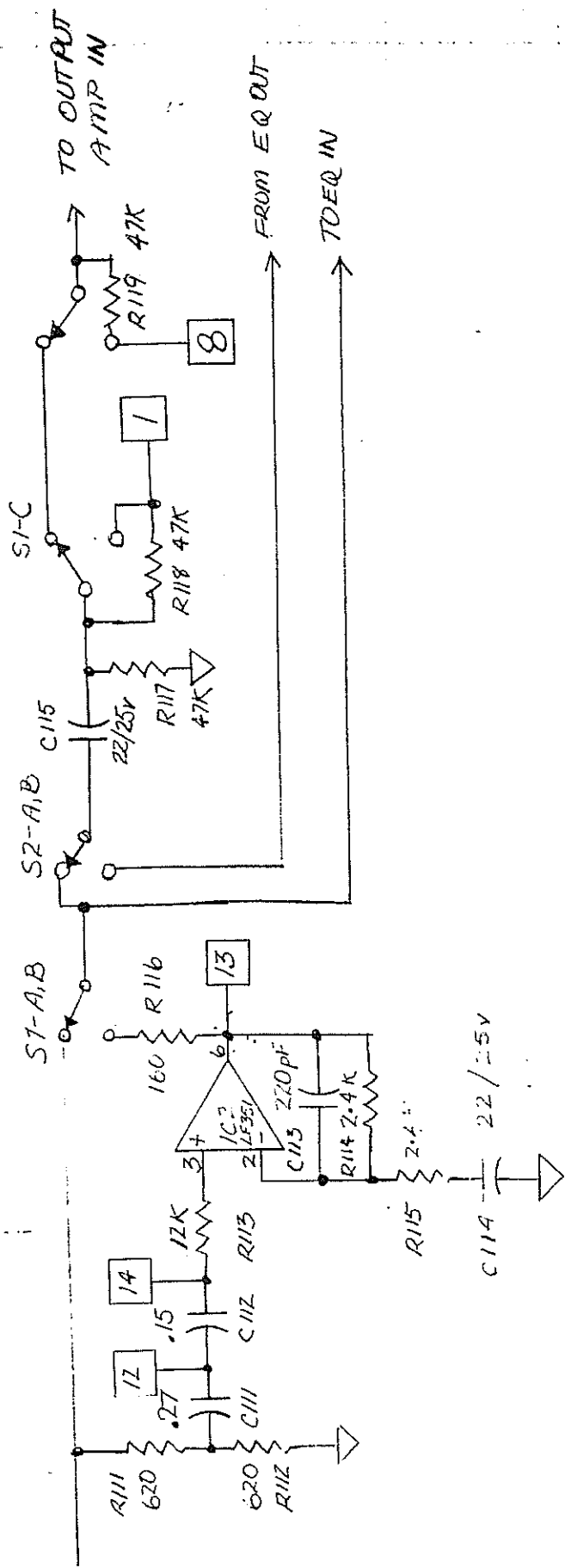

EQF-2
LOW EQ

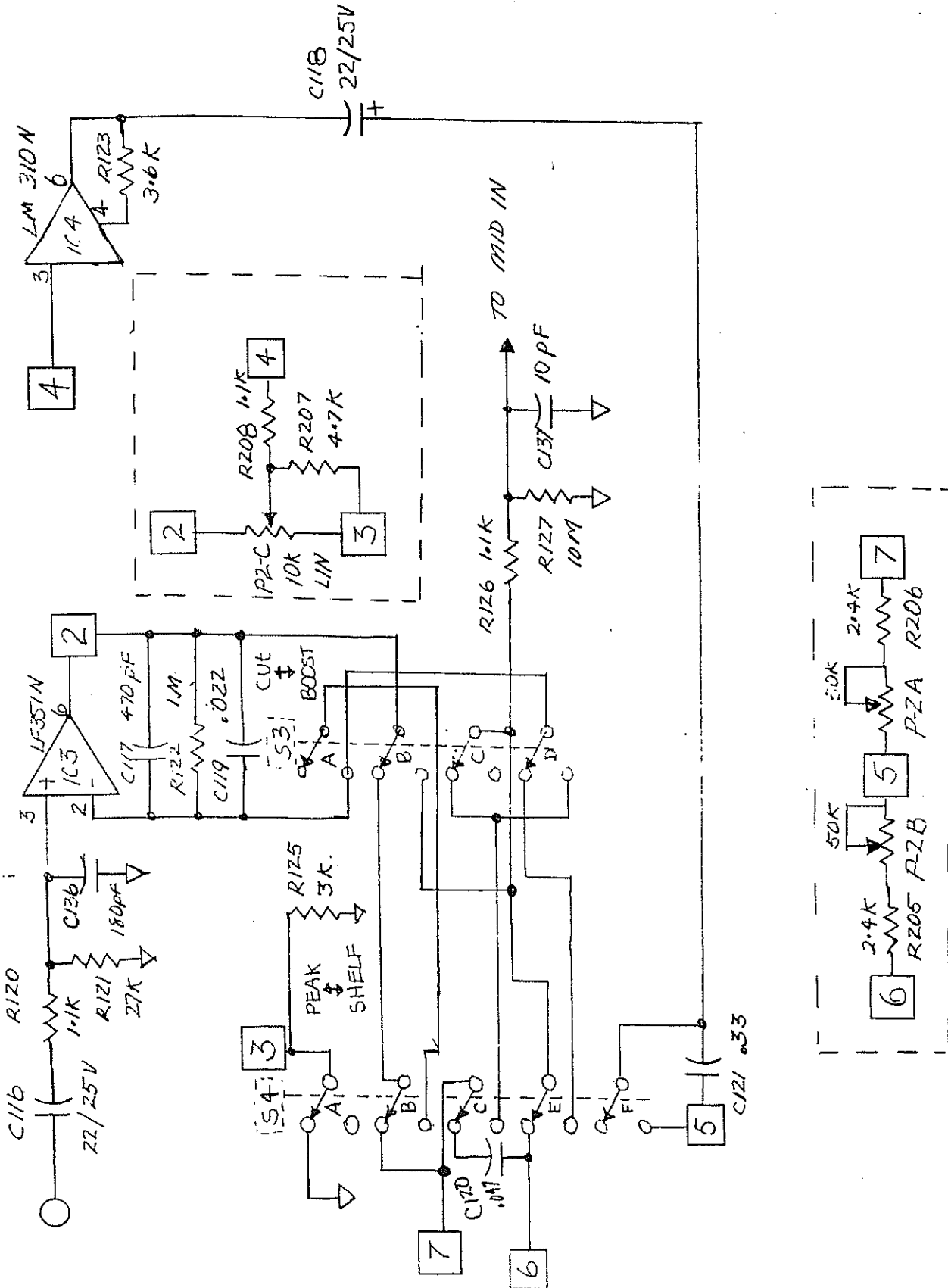

EQF-2
MID EQ

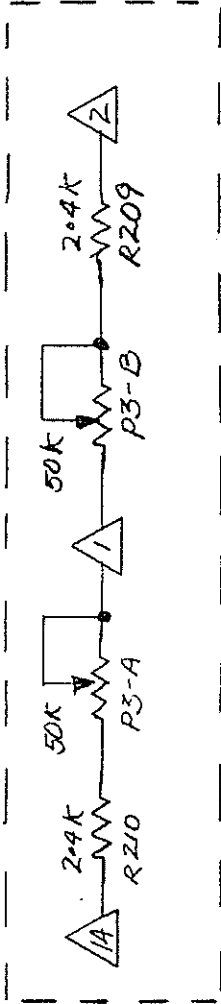
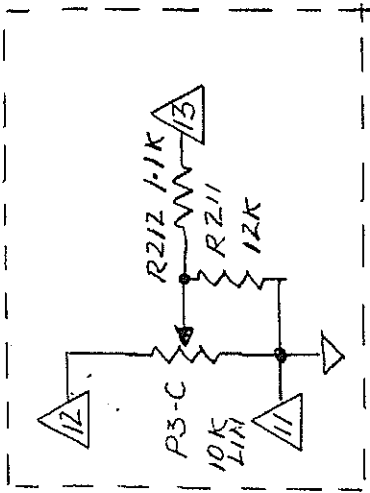
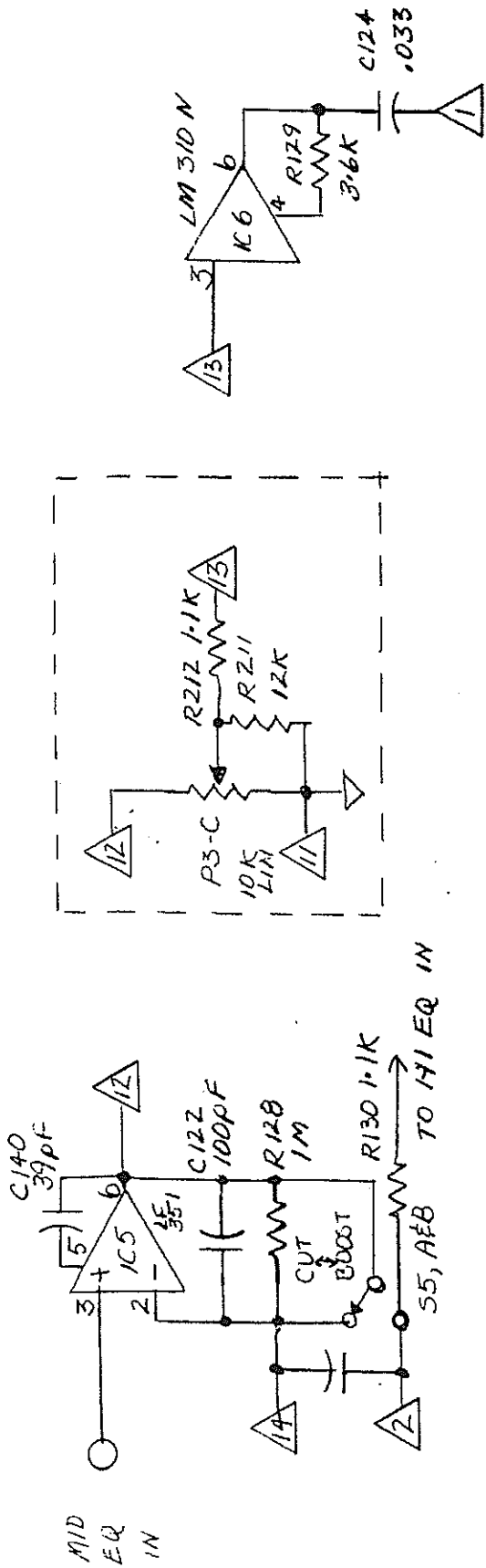

EQF-2
HI EQ BUFFER

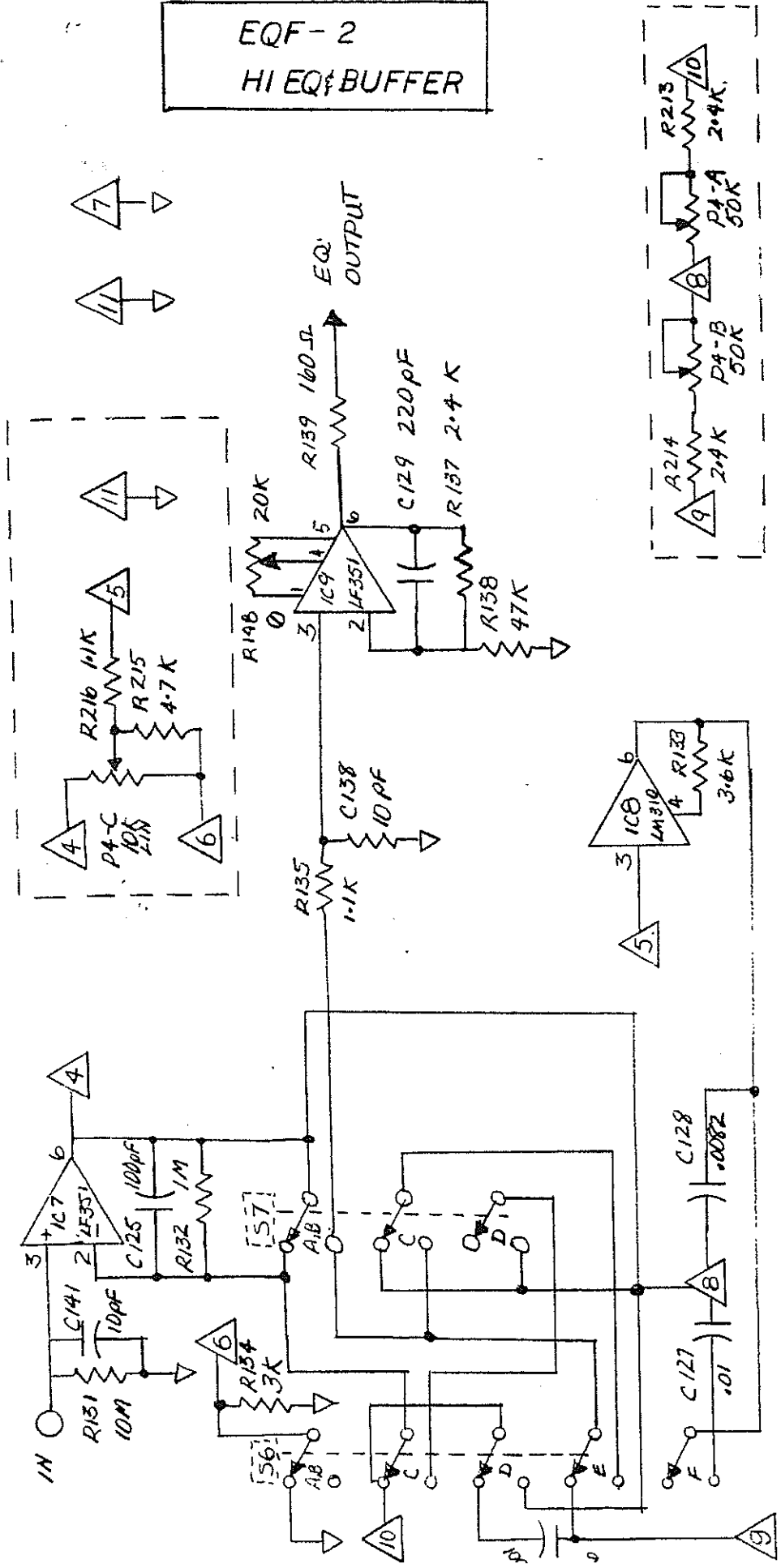
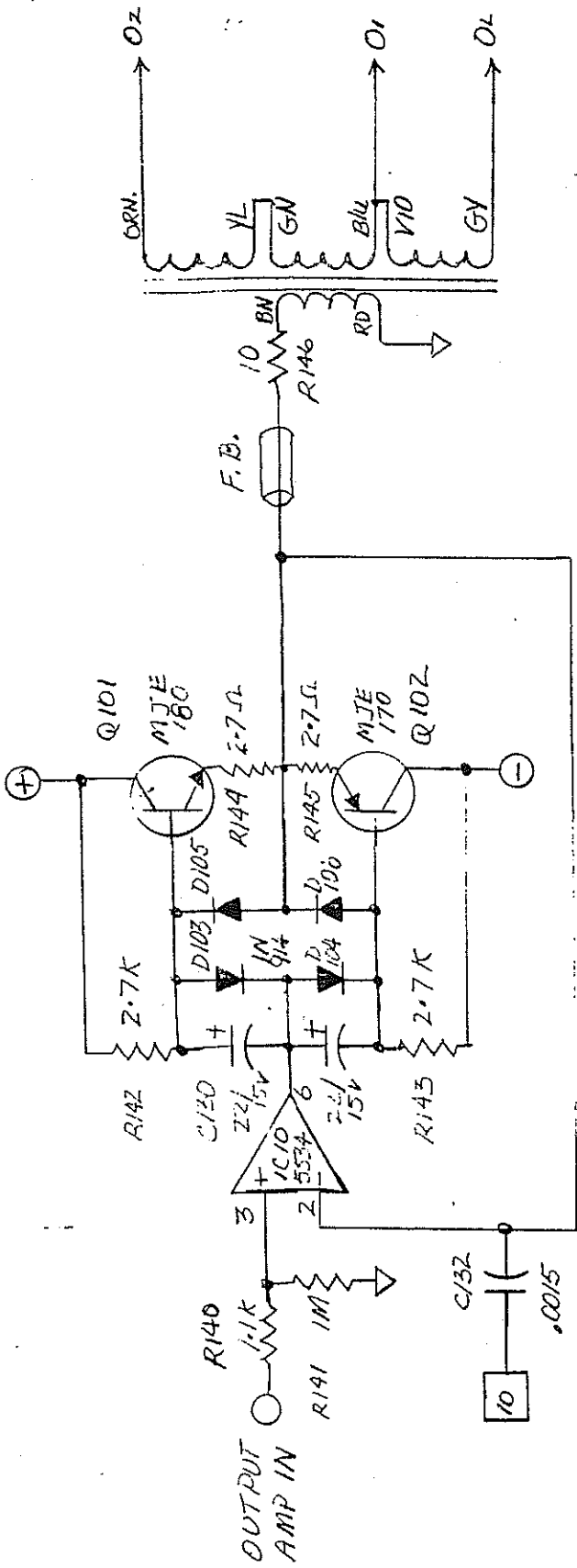
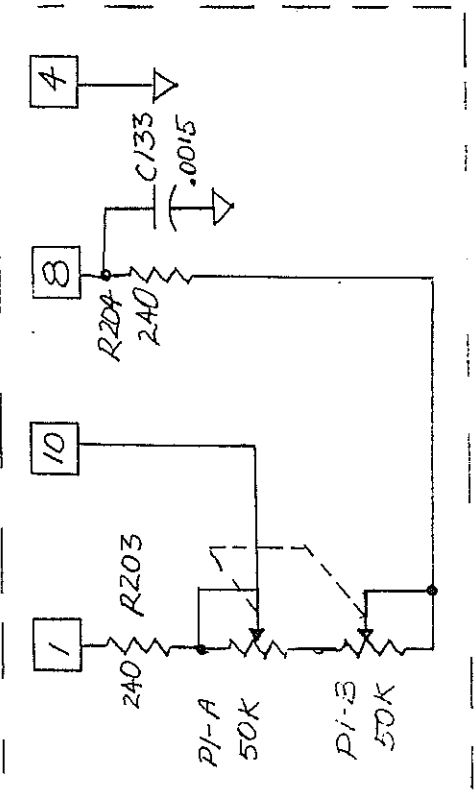

FIGURE 2-13/80 C70



EQF-2
LO PASS, OUTPUT



-R101	15K	-R201	2.4K	-C101	150uf	25V	E
-R102	15K	-R202	2.4K	-C102	150uf	25V	E
-R103	24K	-R203	240	-C103	0.1uf	50V	M
-R104	1.1K	-R204	240	-C104	0.1uf	50V	M
-R105	10K	-R205	2.4K	-C105	0.1uf	50V	M
-R106	1.1K	-R206	2.4K	-C106	0.1uf	50V	M
-R107	2.4K	-R207	4.7K	-C107	22uf	25V	E
-R108	910	-R208	1.1K	-C108	180pf		D
-R109	20K	-R209	2.4K	-C109	220pf		D
-R110	Jumper	-R210	2.4K	-C110	47uf	10V	E
-R111	620	-R211	12K	-C111	0.27uf	100V	S
-R112	620	-R212	1.1K	-C112	0.15uf	100V	S
-R113	12K	-R213	2.4K	-C113	220pf		D
-R114	2.4K	-R214	2.4K	-C114	22uf	25V	E
-R115	2.4K	-R215	4.7K	-C115	22uf	25V	E
-R116	160	-R216	1.1K	-C116	22uf	25V	E
-R117	47K			-C117	470pf		D
-R118	47K	-D101	IN4001	-C118	22uf	25V	E
-R119	47K	-D102	IN4001	-C119	0.022uf	100VS	
-R120	1.1K	-D103	IN914B	-C120	0.047uf	100VS	
-R121	27K	-D104	IN914B	-C121	0.33uf	100VS	
-R122	1M	-D105	IN914B	-C122	100pf		D
-R123	3.6K	-D106	IN914B	-C123	0.0047uf	250VS	
-R124	OMIT	-D107	IN914B	-C124	0.033uf	100VS	
-R125	3K	-Q101	MJE171	-C125	100pf		D
-R126	1.1K	-Q102	MJE171	-C126	0.001uf	250VS	
-R127	10M			-C127	0.01uf	100VS	
-R128	1M	-L101	FB-2	-C128	0.0082uf	250VS	
-R129	3.6K			-C129	220pf		
-R130	1.1K	-IC101	LF351N	-C130	22uf	15V	T
-R131	10M	-IC102	LF351N	-C131	22uf	15V	T
-R132	1M	-IC103	LF351N	-C133	0.0015uf	250VS	
-R133	3.6K	-IC104	LM310N	*-C134	1000uf	4V	E
-R134	3K	-IC105	LF351M	*-C135	10pf		D
-R135	1.1K	-IC106	LM310N	-C136	180pf		D
-R136	10M	-IC107	LF351N	-C137	10pf		D
-R137	2.4K	-IC108	LM310N	-C138	10pf		D
-R138	47K	-IC109	LF351N	-C139	56pf		D
-R139	160	-IC110	NE5534N or	-C140	39pf		D
-R140	1.1K		LF351N (opt T)	-C141	10pf		D
-R141	1M						
-R142	2.7K						
-R143	2.7K						
-R144	2.7						
-R145	2.7						
-R146	10						
-R147	20K Trimmer						
-R148	20K Trimmer						

M = Monolythic
D = Disc ceramic
S = Stacked foil
T = Tantalum
E = Electrolytic

*Not used opt Transformer

EQF-2
INPUT & EDGE CONN.

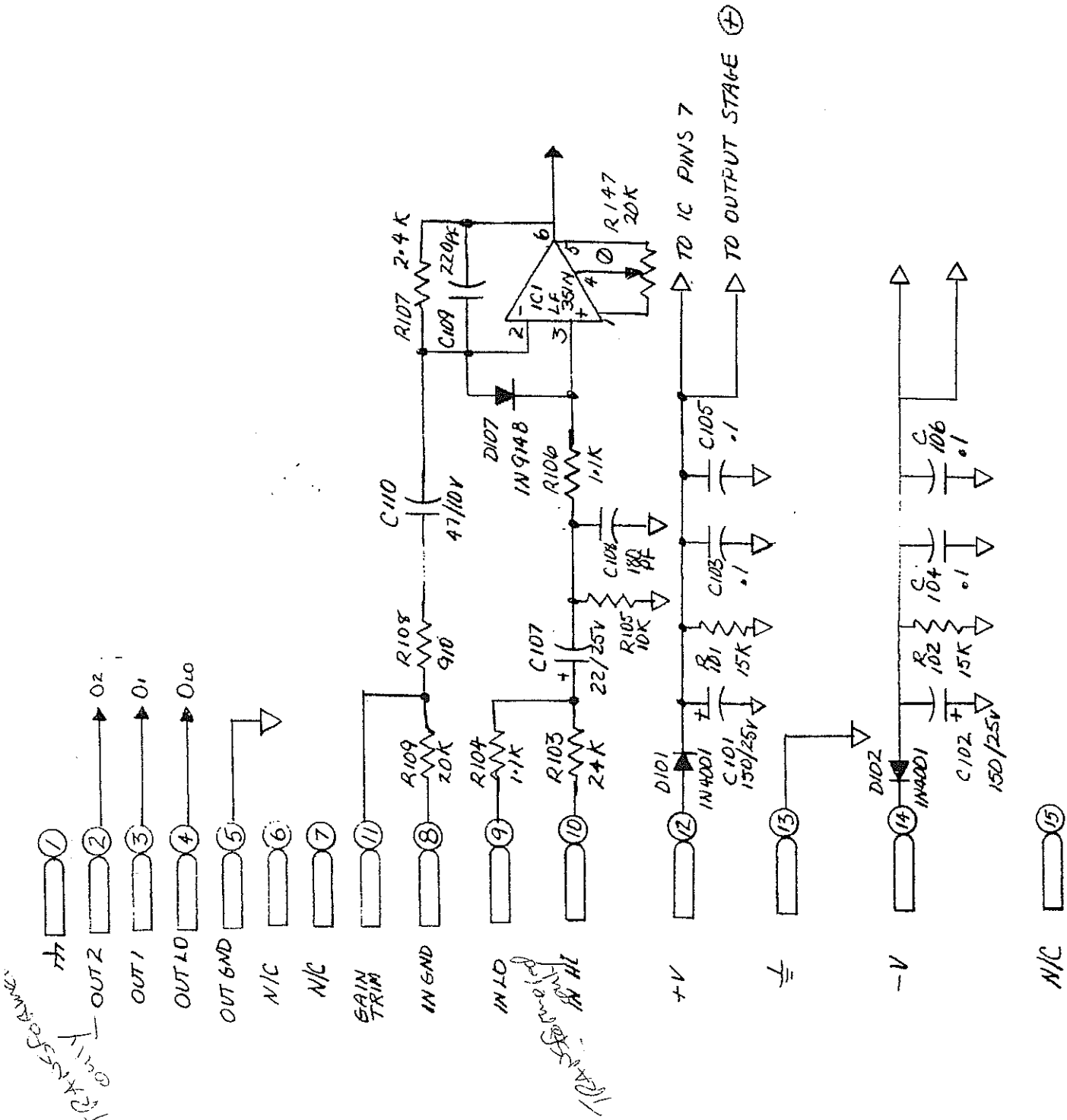

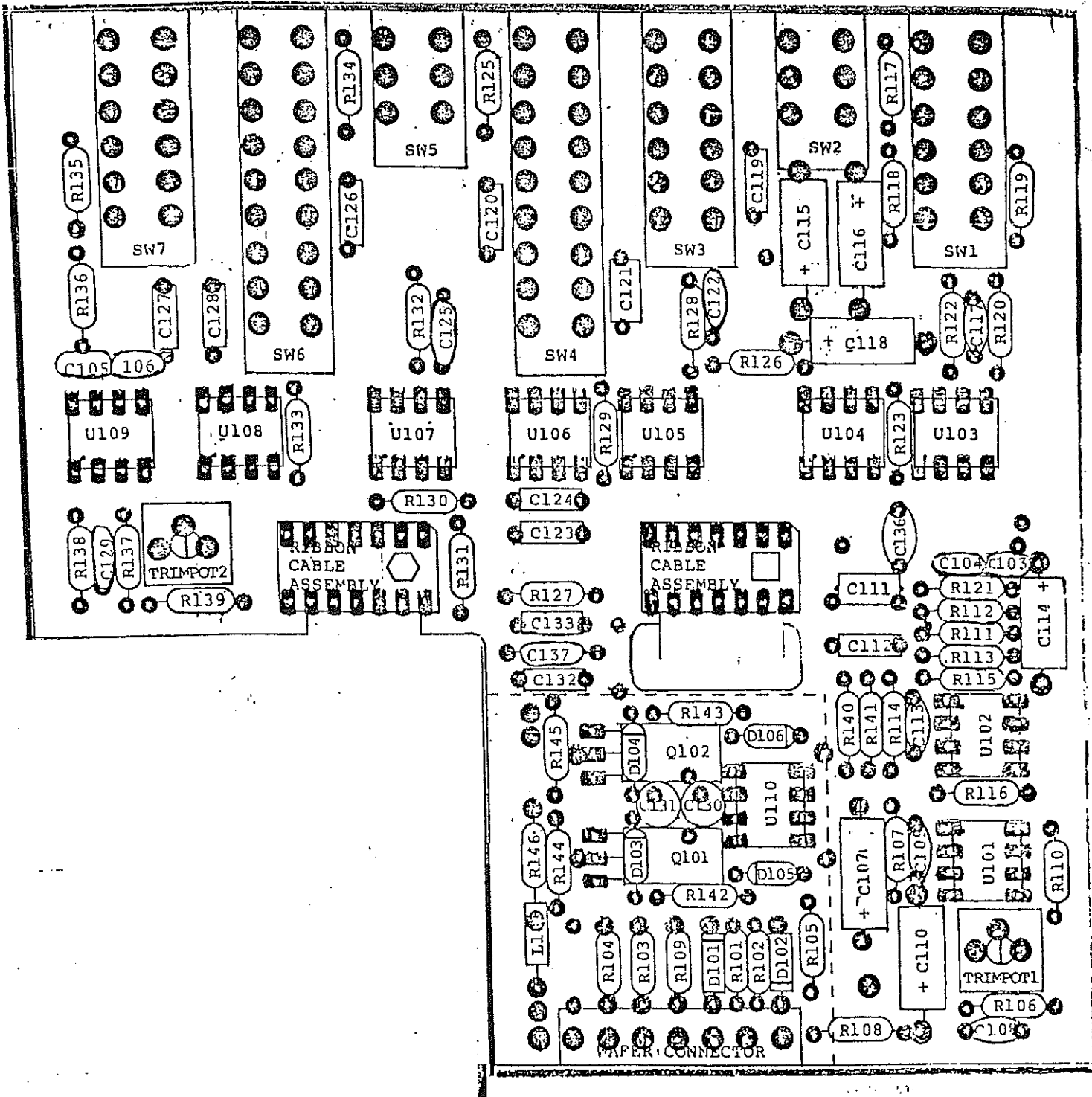

S/N 1109 - DOWN

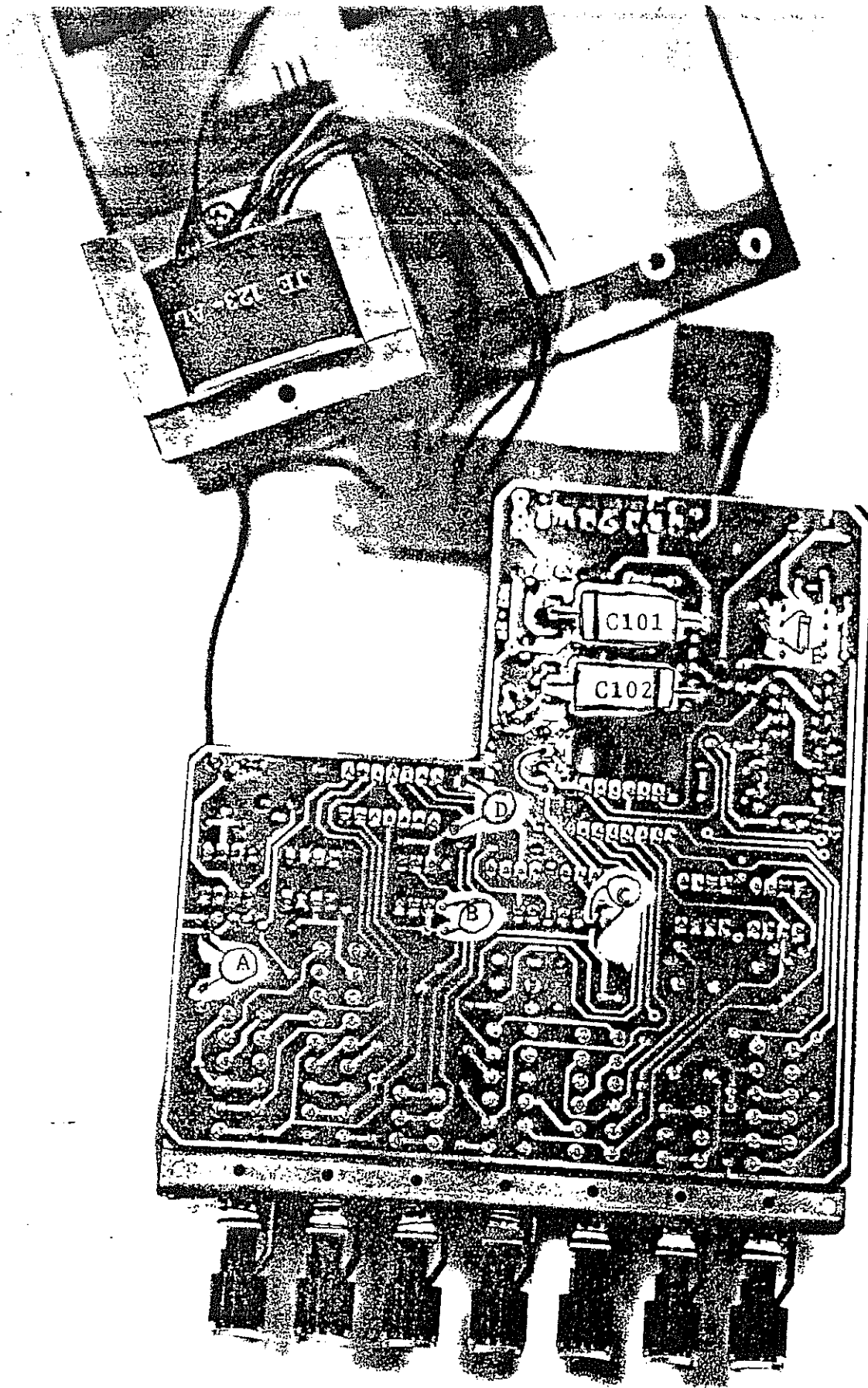

- A C138
- B C139
- C C140
- D C141
- E D107

S/N 1109-DOWN

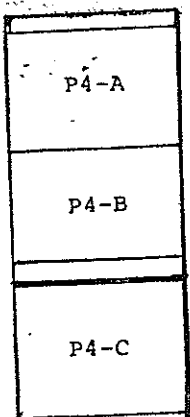

FASTENER
2-56

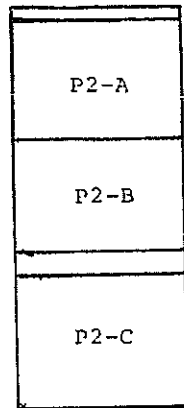
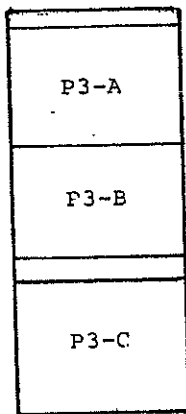

FASTENER
2-56

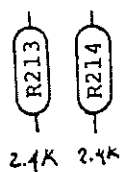
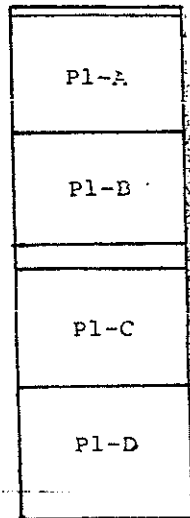

FASTENER 2-56

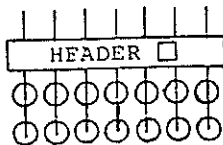
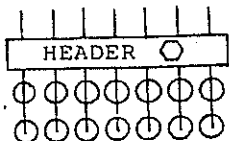

○ THREADED STUD 4-40x $\frac{1}{2}$ "

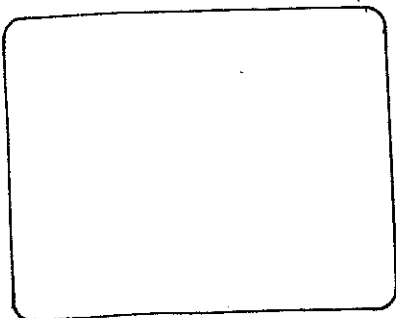

○ THREADED STUD 4-40x $\frac{1}{2}$ "

THREADED STUD 4-40x $\frac{1}{2}$ " ○

EQF-2 BOTTOM CARD
S/N 1109-DOWN

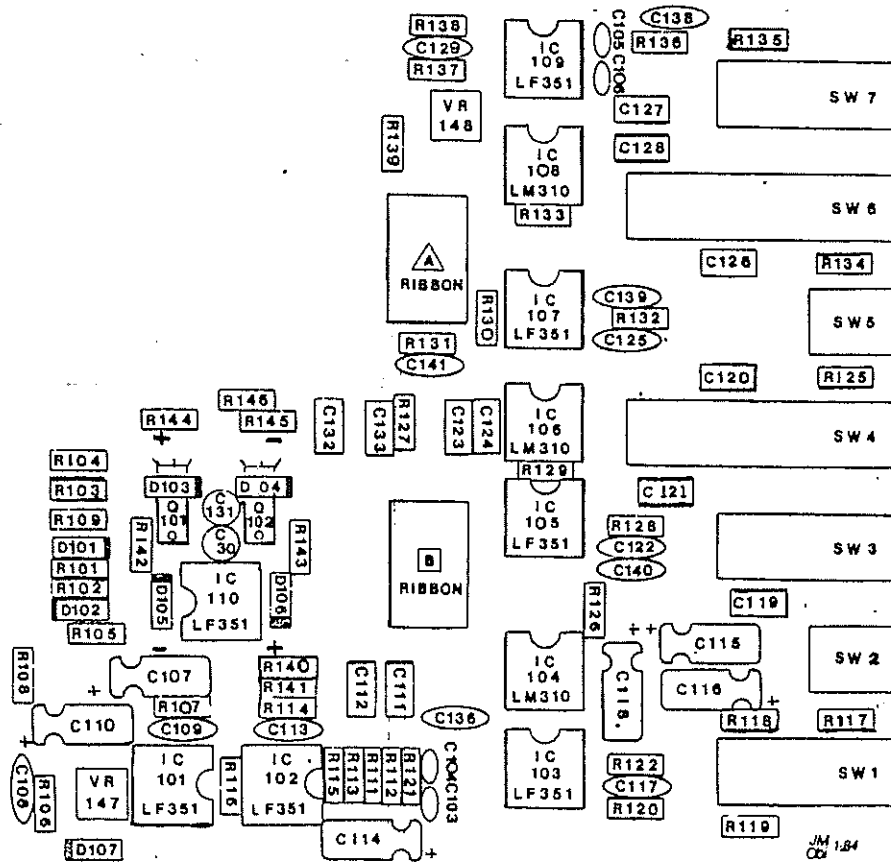

PARTS LAYOUT
S/N 1110-UP

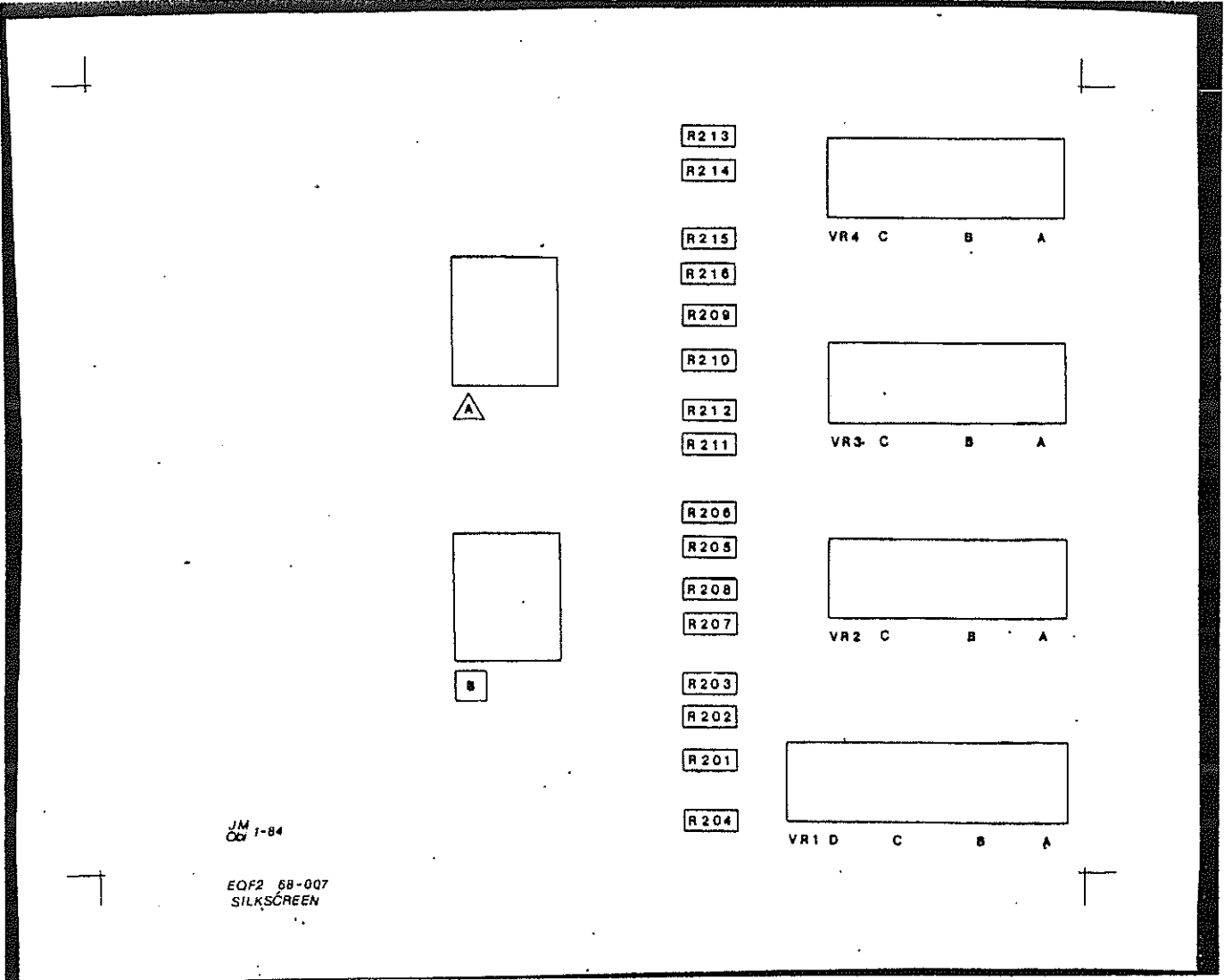

JM
CBI 1-84

EQF2 68-007
SILKSCREEN

S/N 1110-UP

EQF-2 NO TRANSFORMER

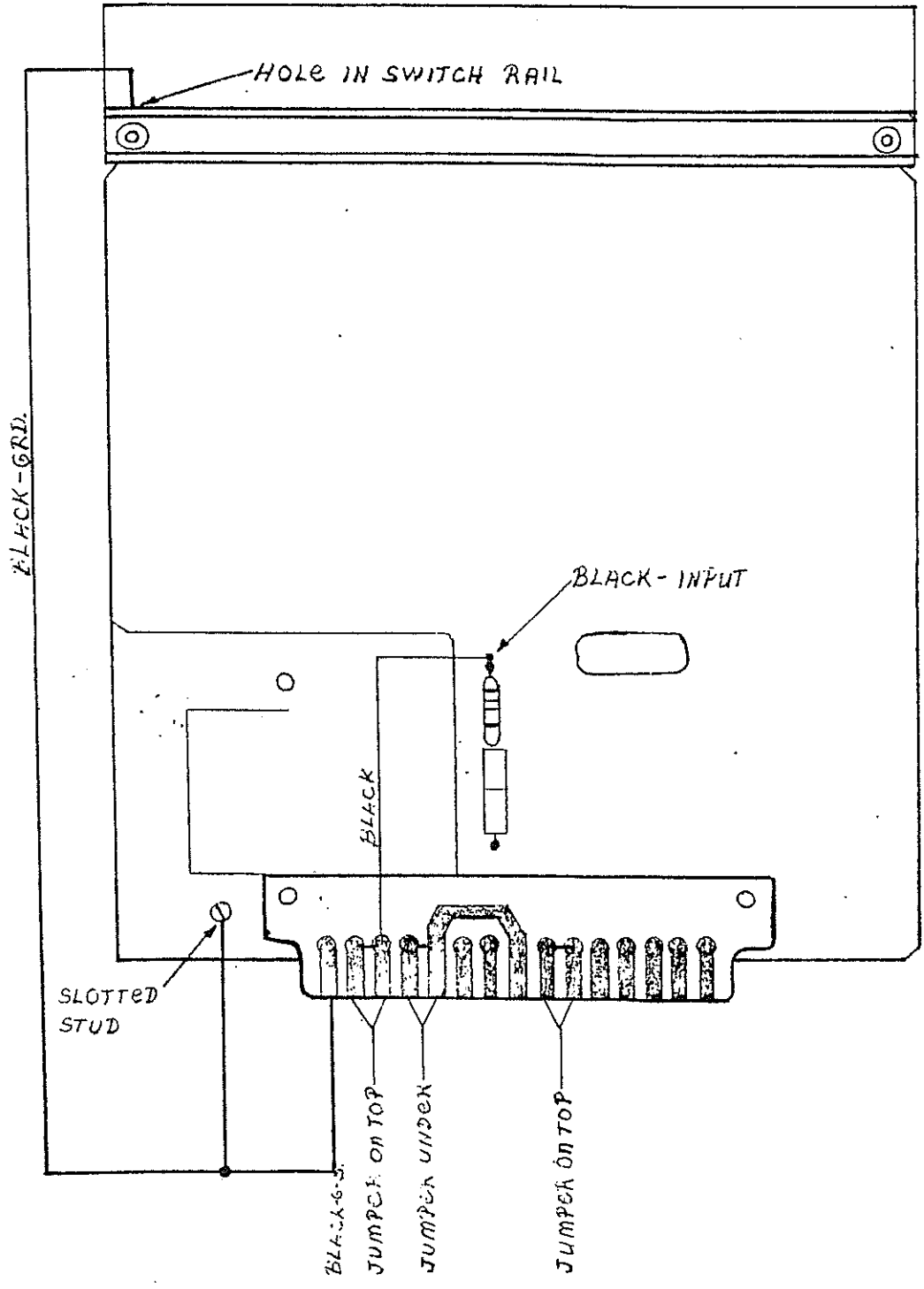

WIRING DIAGRAM

DWG. BY
K L.

EQF-2 NO TRANSFORMER

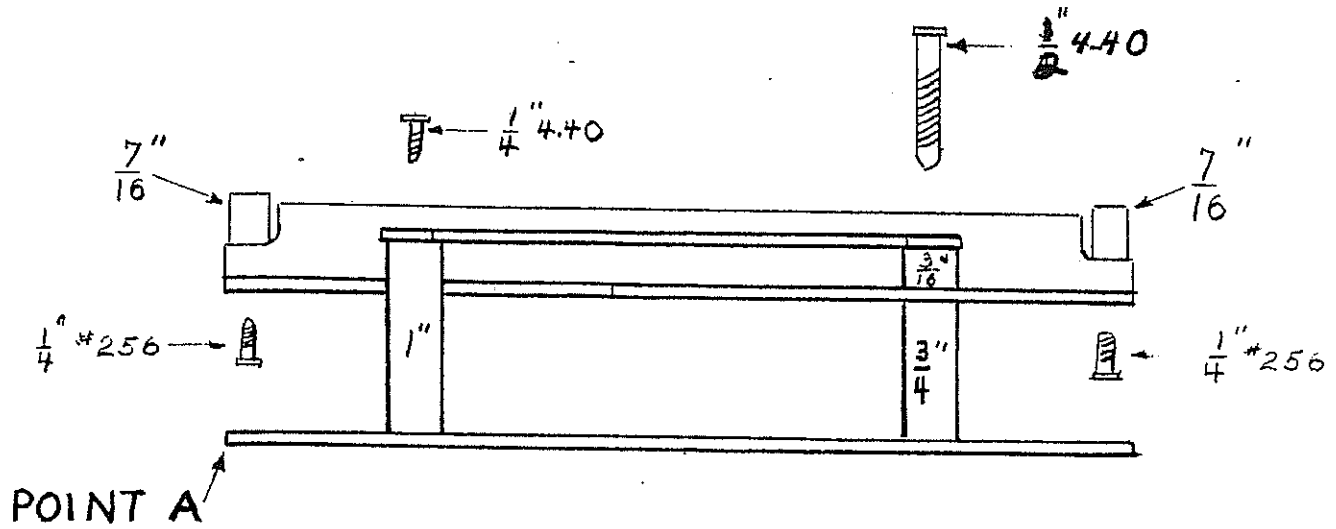

BACK VIEW

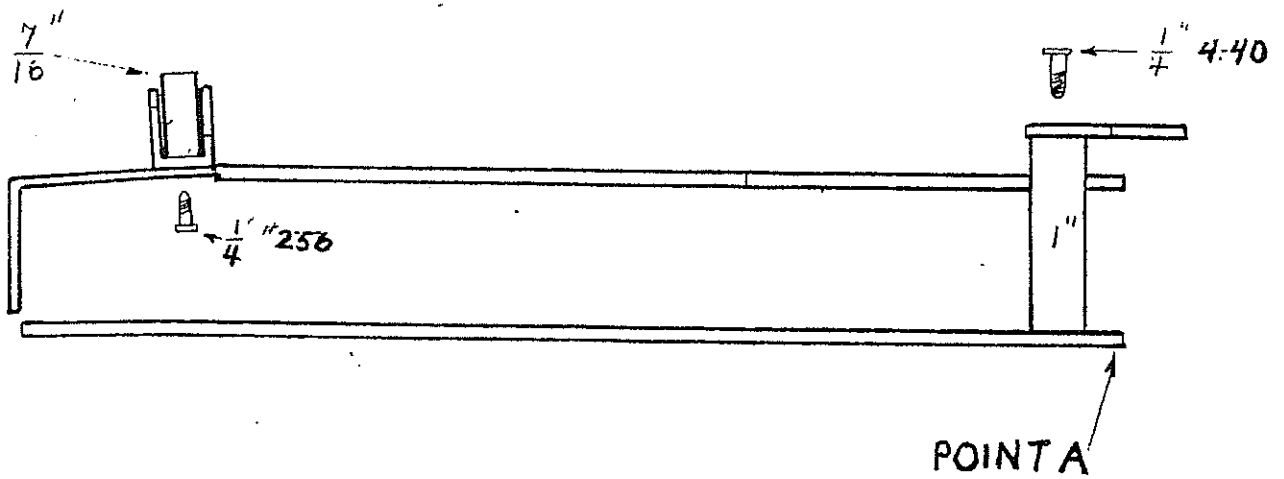

SIDE VIEW

SCREW + SPACER DESIGNATIONS

DWG. BY
K. L.

EQF-2 TRANSFORMER

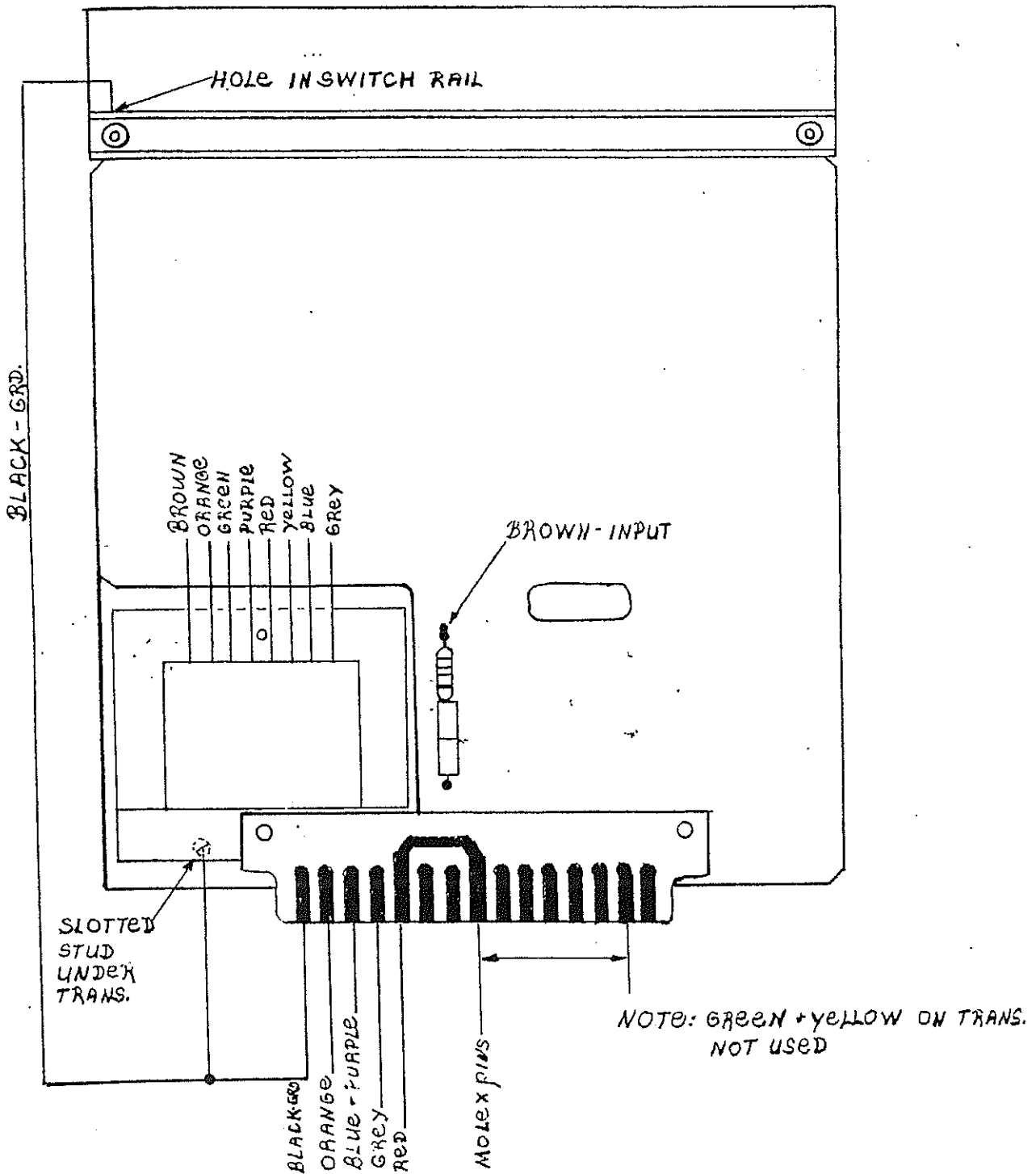

WIRING DIAGRAM

DWG. BY
K.L.

EQF-2 TRANSFORMER

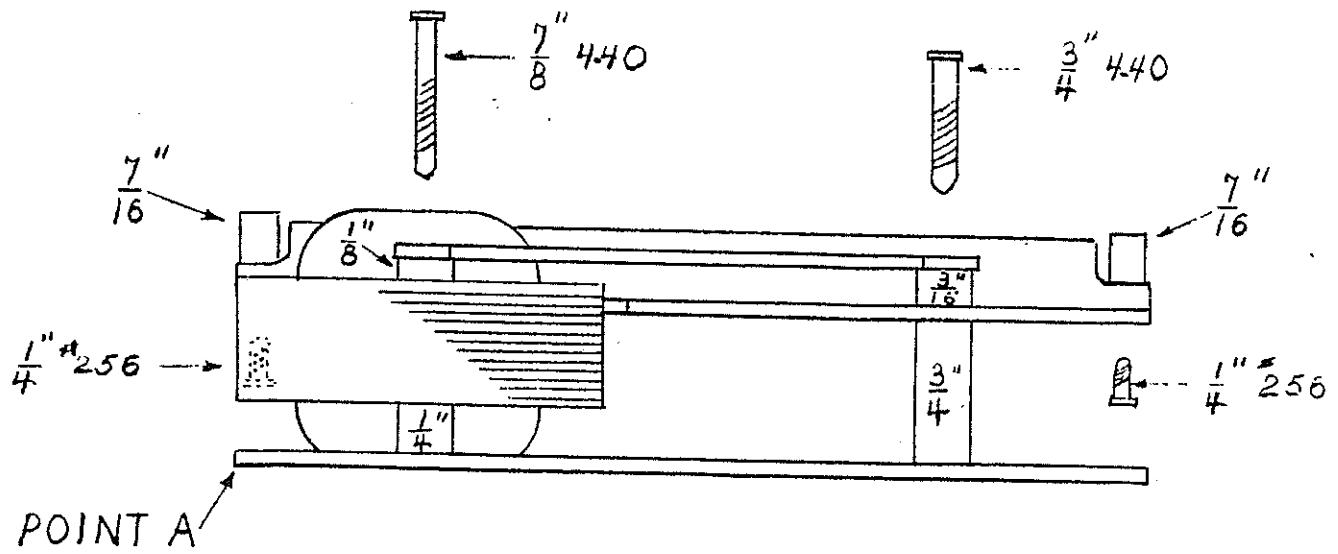

BACK VIEW

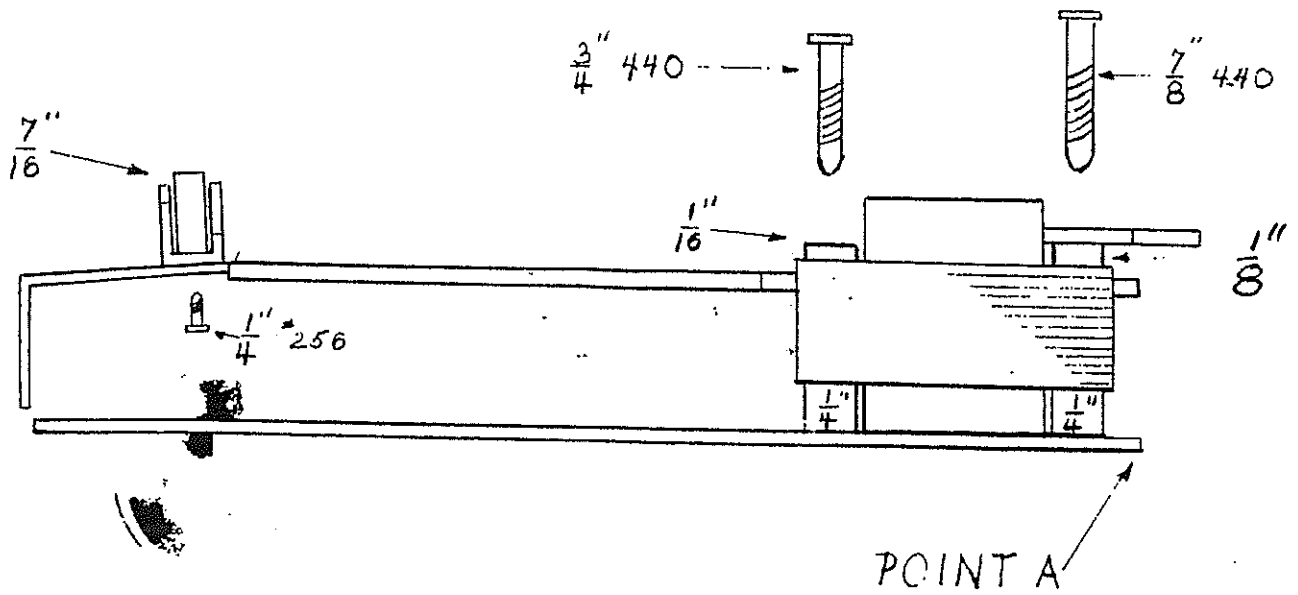

SIDE VIEW

SCREW + SPACER DESIGNATIONS

DWG. BY

K.L.

EQF-2 BOTTOM PLATE

63-003 A.B.Y. NUTS
KF2-256

63-003 A.B.Y. NUTS
KF2-256

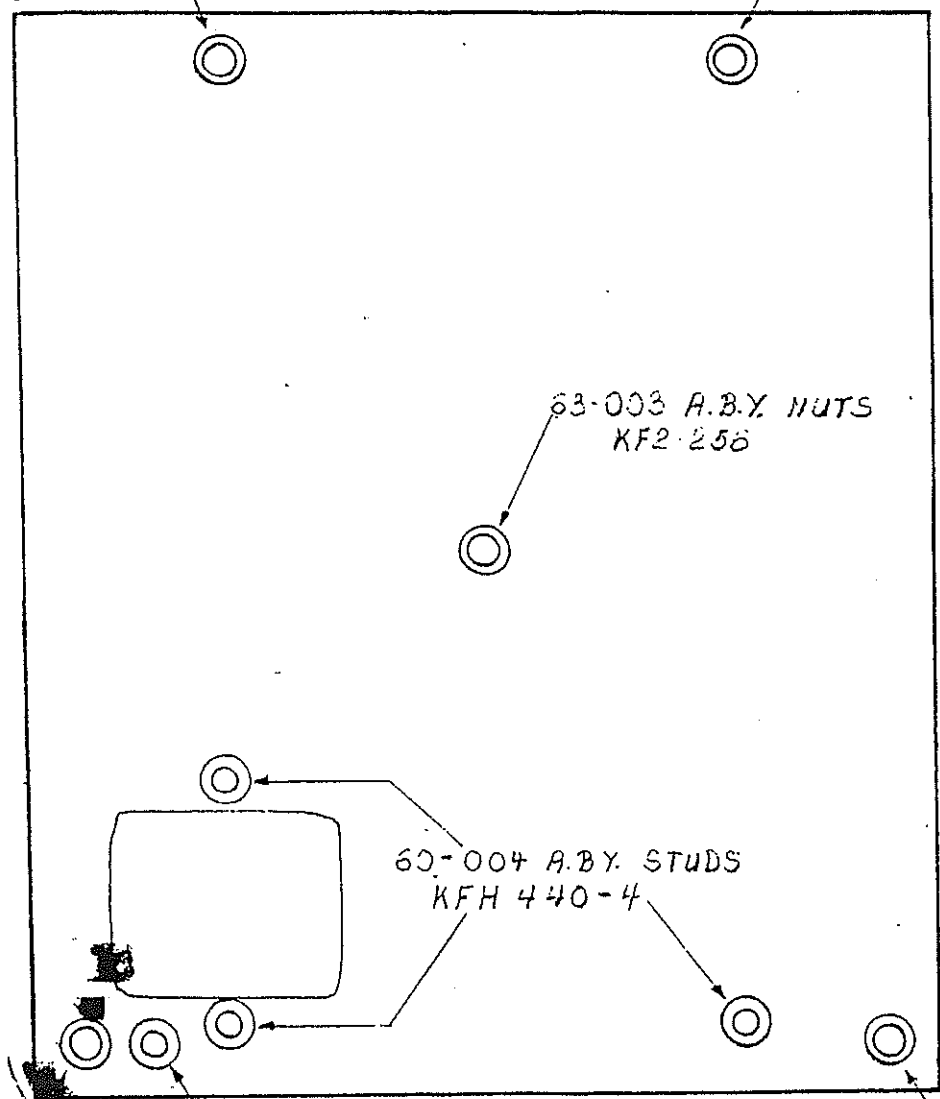

63-003 A.B.Y. NUTS
KF2-256

60-004 A.B.Y. STUDS
KFH 440-4

63-003 A.B.Y. NUTS
KF2-256

SLOTTED STUD
KST-120-5 ET

63-003 A.B.Y. NUTS
KF2-256

HARDWARE DESIGNATIONS

CV16.BY
K.L.

EQF-2 DC OFFSET CALIBRATION PROCEDURE

If it ever becomes necessary to replace one of the op-amps, this procedure will re-null the overall d.c. offset of the EQF-2. See drawing for test points.

1. Attach noise filter to input of oscilloscope.
2. Set scope on 5mv. per division scale and DC.
3. Ground scope to an audio Gnd. on EQF-2 test cable.
4. Turn all EQ knobs fully clockwise.
5. Attach test lead from noise filter on scope to either of the center pins of SW2 ("EQ" switch) on EQF-2.
6. Engage "Filter" on EQF-2 and adjust "Position" knob on scope for center or "0" line of the screen. This is your DC reference.
7. Disengage "Filter" and adjust "Trimpot One" on EQF-2 so line matches with reference. When aligned properly, line will not move when "Filter" is engaged/disengaged.
8. Engage "EQ" on EQF-2 and adjust "Trimpot Two" so line matches with reference. (As in step #7).
9. Double check that when "EQ" or "Filter" is engaged or disengaged the line stays stationary.

NOTES ON ABOVE

1. If DC is so far out of alignment that it cannot be calibrated by either trimpot, try swapping some of the #351 IC's around (usually #2 with #9 or #1 with #9 works best). After moving IC's around re-calibrate DC.
2. If possible, avoid calibrating so trimpot is at end stops. You should have enough adjustment left in trimpot to be able to pass reference line by at least 5mv. If this is not possible see "Note One".

EQF-2 DC OFFSET ILLUSTRATIONS

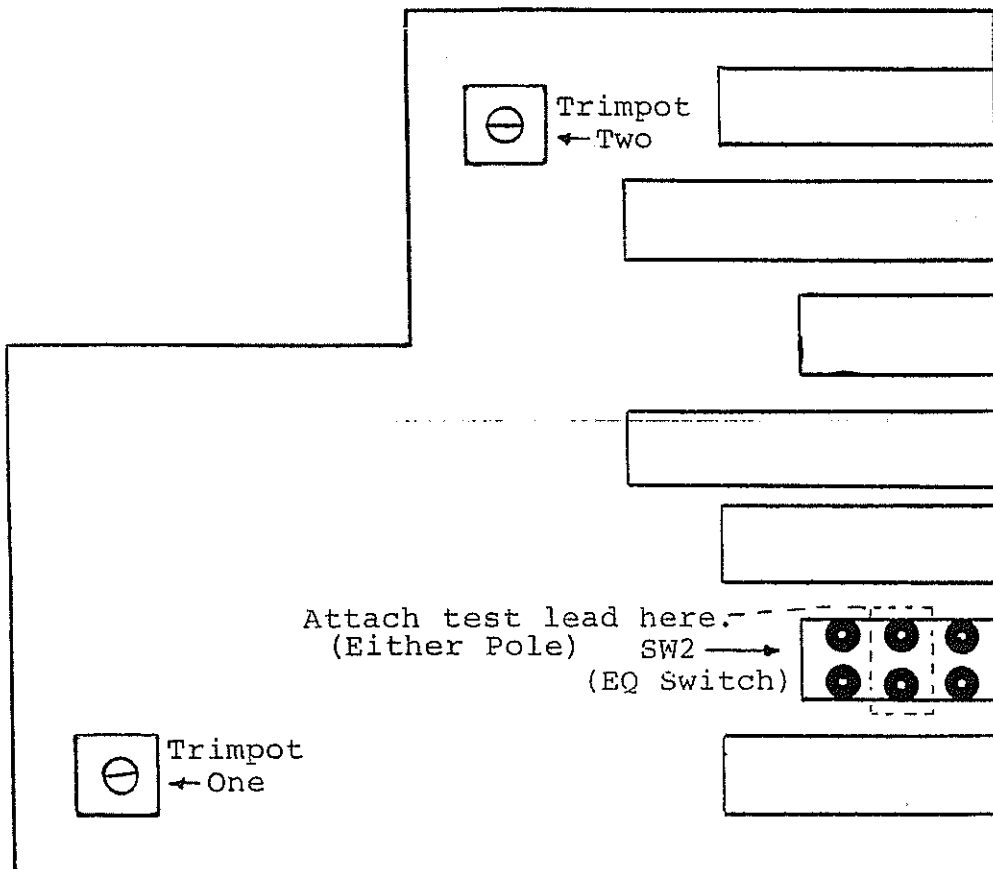

EQF2 TOP CARD

DC CALIBRATION HINT

To aid in getting accurate DC readings with high scope sensitivity, we recommend constructing a simple low pass (noise) filter as described below.

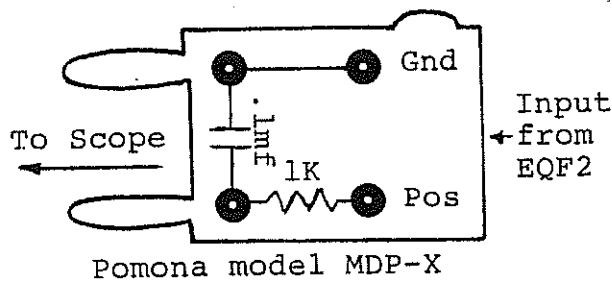

APHEX SYSTEMS LTD.

<u>ITEM</u>	<u>PRICE EACH</u>	
<u>APHEX II BROADCAST / STUDIO AURAL EXCITER</u>	<u>Stereo</u>	<u>Mono</u>
1 - 3	\$2950	\$2350
4 - 7	2750	2200
8 - up	2600	2100
 <u>EQF-2 Five Band Parametric Equalizer/ Filter with Jensen Transformer (+30 dBm Output)</u>		
1 - 7	\$549	
8 - 15	525	
16 - up	495	
without transformer (+20dBm Output) deduct \$20.00.		
 <u>CX-1 Compressor/Expander</u>		
Same price breaks as EQF-2 above	\$549	
 <u>R-1 Rack for ten EQF-2's or CX-1's above</u>		
	\$195	
 <u>PS-1 Rackmount Power Supply for R-1 ±16V @3.4A</u>		
	\$275	
 <u>4B-1 Self-Powered 4 Module Rack</u>		
	\$349	
 <u>2521 Operational Module</u>		
1 - 49	\$35	
50 - 99	27.50	
100- up	22.50	
 <u>OAS-24 Outboard Grouping System</u>		
OAS-24 (9 Control Module, 1 master 24 VCA's)	<u>Rack Mount</u>	<u>In Portable Case</u>
	\$7,800	\$8,000
Replacement VCA Modules.....	\$150	
Control Module.....	300	



R-1 MODULAR
INTERFACE
PS-1 POWER
SUPPLY

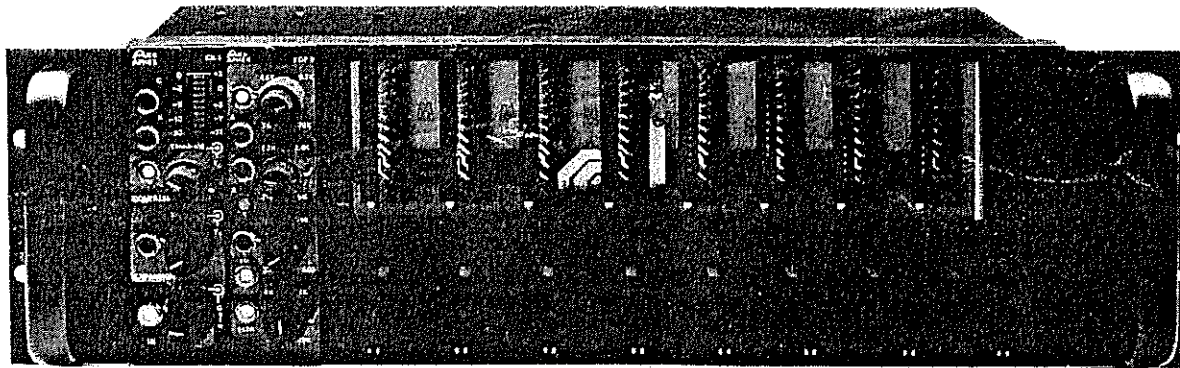

R-1 MODULAR INTERFACE

The R-1 is a compact rack mount package designed to hold ten EQF-2 or CX-1 size packages. The R-1 backplane provides barrier strip access to all inputs and outputs; power and ground are bussed.

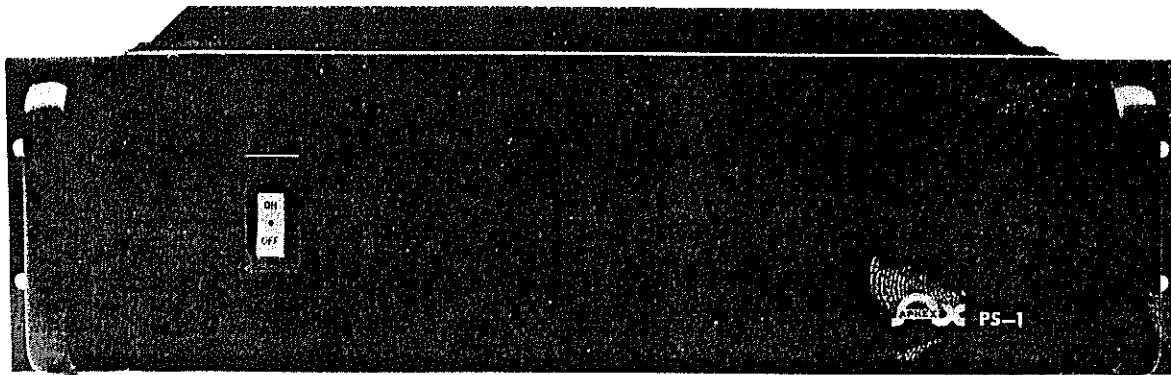

PS-1 POWER SUPPLY

The PS-1 is a rack mount power supply designed to complement the R-1 in looks and function. Its $\pm 16V @ 3.0$ Amps will adequately power anything the R-1 can hold. Your modules are protected by built-in Over Voltage Protection and illuminated circuit breaker/power switch.



APHEX SYSTEMS LTD.



4B-1
SELF POWERED
MODULAR
MINI-RACK

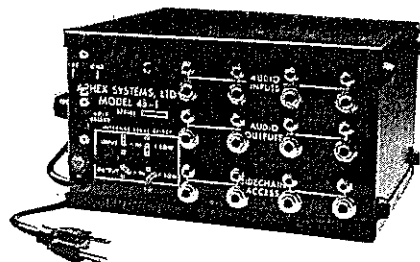
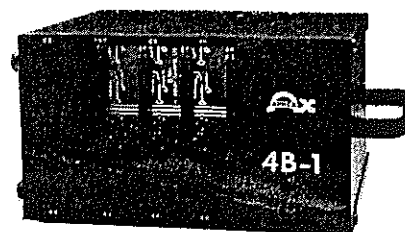

- SUPPORTS 4 APHEX AUDIO MODULES
- ALL PATCH POINTS ON REAR (1/4" and T-T SIZES)
- SELF-POWERED FOR 115-230V
- EXTREMELY COMPACT AND PORTABLE FOR THE ENGINEER/PRODUCER ON THE GO
- HI/LO LEVEL SELECT FOR EACH INPUT/OUTPUT

SPECIFICATIONS

DC SUPPLY – REGULATED \pm 16V @ 500mA

POWER REQUIREMENTS – 115-230 V.A.C., 25 WATTS

SIZE - 5.75" H x 11" WX 7.75" D (EXCL. KNOBS)

WEIGHT - (EMPTY) 9 lbs., 2 oz.



APHEX SYSTEMS LTD.