

Title: **RMX 2450 AC Wire Routing**
 Bulletin #: RMX0004 Issue Date: November 3, 2000
 Models Affected: RMX 2450 Bulletin Revision: A
 Production Range: 01/2000–10/2000 (serial # 0100xxxxx–1000xxxxx)

Description

In the RMX 2450, the wiring to the AC switch is routed at the factory along the side of the chassis and secured with tie wraps to small loops (called bridge lances) in the chassis. One bridge lance lies right next to the toroidal power transformer with only a few millimeters to spare. In shipping or handling the amplifier, the potential exists for the transformer to shift and/or the chassis to flex, causing the transformer to pinch or abrade the wires against the bridge lance, and possibly cause it to cut through the insulation on the wire. This could short-circuit the AC current to the chassis, a very dangerous situation.

This bulletin describes a procedure rerouting the AC wiring so it is not susceptible to being pinched and shorted to the chassis.

NOTE: This modification corrects a potentially dangerous situation and is mandatory on all RMX 2450 amplifiers built in the affected production range.

NOTE: Any repair to the AC primary wires, beyond installing the protective sleeve described in this bulletin, must be performed at an authorized service center or the factory.

Units affected

The units affected are RMX 2450 amplifiers manufactured from January through October 2000.

Visual inspection

First, verify that the amplifier's serial number places it in the affected production range. If it does, see whether it has already been modified: look through the ventilation slots on the left side panel of the chassis, near the front. If you see brown wires near the upper slots and no insulator board between the power transformer and the side wall of the chassis, the amplifier needs to be modified. If you can see insulator board at the rear edge of the slots—and not brown wires—between the transformer and the chassis, the amplifier has already been modified.

Instructions

Tools and materials required:

- Long-nose pliers
- Small diagonal cutters
- Wire strippers
- #2 Phillips screwdriver
- Torque wrench & 13 mm or ½-inch socket
- Loctite® 262 with primer N or T

Parts kit SG-000211-AC:

- 1 pre-cut piece of insulator board
- 2 tie wraps
- Plastic sleeving
- 3 replacement top cover screws

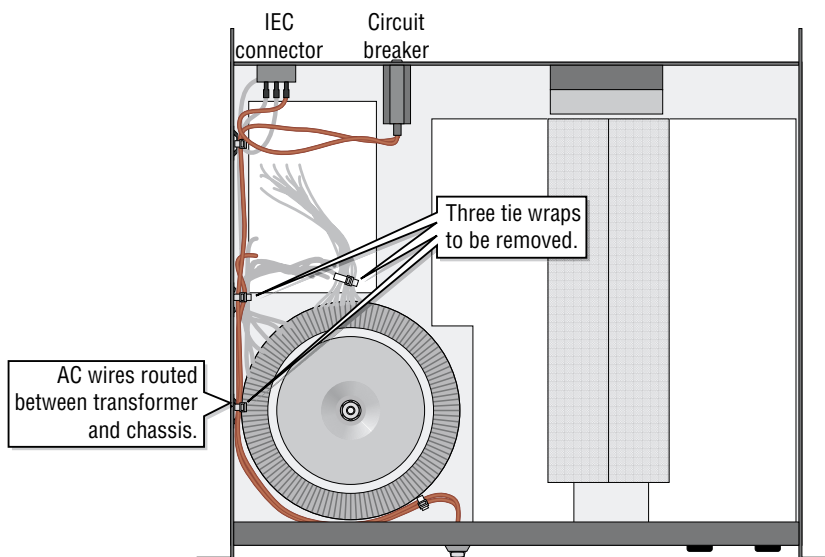

Figure 1. The amplifier before modification.

Procedure: Rerouting the AC wires

1. Disconnect the amplifier from AC and wait a couple minutes for internal voltages to bleed down. Remove the top cover.
2. Cut and remove the three tie wraps shown in Figure 1. Be careful not to cut into the wires or their insulation.
3. Disconnect the brown AC wires from the power switch. Lift the wires out from between the transformer and the chassis.

4. Check the power transformer. Visually inspect it for possible damage by the bridge lance. If the transformer's wrapping or the windings underneath have been damaged, it must be replaced; contact QSC Technical Services for information.

If the transformer mounting is loose, tighten the nut to 115 lb-in (9.5 lb-ft) or 13 N-m and apply thread locking compound.

5. Inspect the wires for damage. If on either wire the insulation is cut or crushed, exposing the conductors within, or if any of the copper strands in the wire are severed, the wire must be replaced before completing this service procedure.

Replacing the wire is covered in a separate service bulletin and must be performed only by QSC factory service or by an authorized service center. Contact QSC Technical Services for information.

6. Reroute the wires around the transformer as shown in Figure 3.
7. Slide the large sleeving over the two wires and reattach the quick-connect terminals to the switch terminals.
8. Orient the insulator board with its hole up and to the rear. Slide it into the space between the transformer and the bridge lance on the side of the chassis, and between the wires and the chassis (Figure 2). Place the hole in the insulator board over the middle bridge lance.
9. Slip a tie wrap through the bridge lance; it will hold the insulator board in place. Bundle the wires with the tie wrap so they are supported, but do not tighten the tie wrap so much that it strains them.
10. Bundle the two brown wires with the secondary wires and bind them all with a tie wrap.

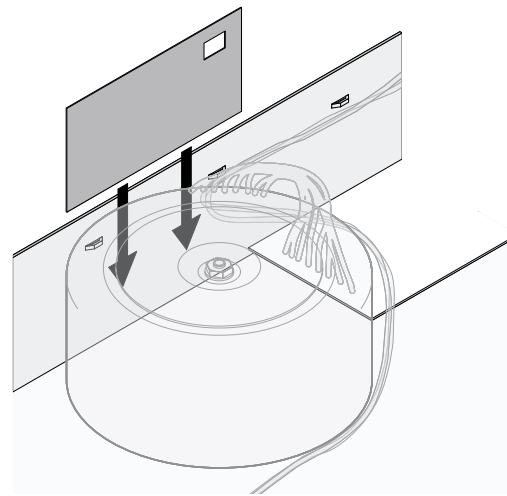

Figure 2. Inserting the insulator board between the chassis and the transformer.

Procedure: Finishing the repair

11. Re-install the top cover; if any screws are stripped or damaged, replace them with the extras provided in the kit. Connect the amplifier to an AC source and make sure the amplifier turns on. If a HIPOT tester is available, test the amplifier to 2250 volts. The amplifier can be returned to use.

Contact information

If you need any further information regarding this service procedure, please contact QSC Technical Services at the addresses or numbers below.

Telephone: 800-772-2834 (within USA only)
714-957-7150

Fax: 714-754-6173

E-mail: tech_support@qscaudio.com

Web site: www.qscaudio.com (product info/support)
www.qscstore.com (on-line accessory and replacement component sales)

Postal and parcel address:

QSC Audio Products, Inc.
Technical Services Group
1665 MacArthur Blvd.
Costa Mesa, CA 92626 USA

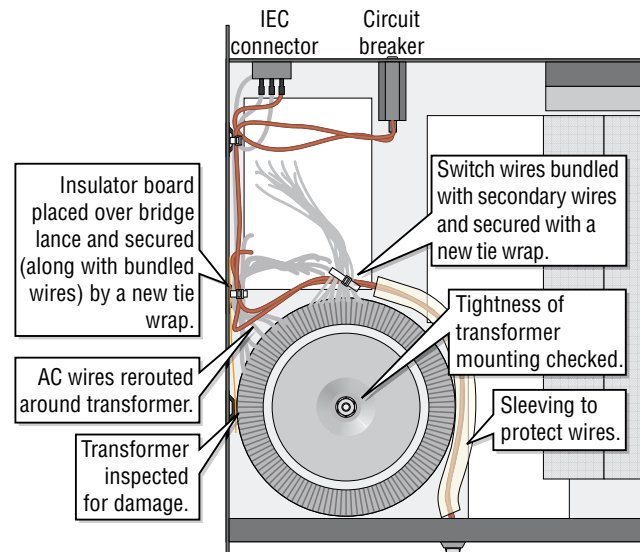

Figure 3. The amplifier after modification.