

# BOGEN<sup>®</sup>

COMMUNICATIONS, INC.

## PUBLIC ADDRESS AMPLIFIERS

CTS-1035, CTS-1060  
AND CTS-1100

### DESCRIPTION

The Bogen Models CTS-1035, CTS-1060, and CTS-1100 are public address amplifiers designed for use in high-quality sound systems. They combine advanced solid-state design with versatile operating features and the flexibility to meet a wide range of application requirements.

Each CTS-Series amplifier mixes five input signals; either five low-impedance microphones, or a combination of microphone and auxiliary inputs. Switches are used to select MIC 4/AUX 1 and/or MIC 5/AUX 2 operation. Precedence circuitry is provided for the MIC/AUX channels. An internal jumper configuration activates a phantom power supply for condenser microphones. Automatic Level Control (ALC) circuitry compensates for different microphone techniques and assures a uniform output level.

A 2/3-octave equalizer permits boosting or attenuating any of 10 selected frequencies to eliminate feedback, improve intelligibility and increase usable power. Each equalizer slide control has a detented flat position.

Microphone input is via screw-terminal strips; standard Hi-Z phono jacks for the auxiliary inputs accept a tuner, tape/cassette player, line-matching transformer, or tone generator.

An output terminal strip provides standard balanced or unbalanced speaker taps, as well as connections for 25V, 25VCT, and 70V speaker lines. A TAPE OUT jack permits recording the output of the amplifier independent of the master volume or equalizer controls. A PWR AMP jack permits feeding the output of the CTS amplifier to a power amplifier. The use of an accessory transformer, Model WMT-1A, permits feeding a signal from a 500/600-ohm telephone line into the amplifier, or connects the output of the amplifier to a 500/600-ohm telephone line. Remote volume control of the output is possible with the RVC-CTS accessory.

The amplifier operates from a 120-volt, 60Hz source. The power switch illuminates in the "on" position. A three-prong line cord automatically grounds the amplifier when connected to a properly grounded three-wire outlet. Output transistors are protected by a thermal breaker; circuitry is further protected by a resettable circuit breaker.

The CTS amplifiers mount easily in standard equipment racks, using an optional rack panel kit, Model RPK-52.

### INSTALLATION

#### UNPACKING

The amplifier was carefully checked before leaving the factory. Inspect the shipping container and unit carefully for indications of improper handling. If the amplifier is damaged, place an immediate claim with the distributor from whom it was purchased. If the amplifier was shipped to you, place a claim with the carrier in accordance with Federal ICC Regulations.

### POWER AND GROUNDING

The amplifier is supplied with a line cord terminated in a three-prong plug. The line cord must be plugged into a properly grounded outlet providing nominal 120-volt, 60Hz AC. Outlet adaptors may be used provided that the grounding pigtail on the adaptor is properly connected to ground.

### INPUT CONNECTIONS

#### CAUTION

*The following installation instructions are for use by qualified service personnel only. To avoid an electric shock, do not perform any functions requiring removal of the cover of the amplifier unless you are qualified to do so.*

### LOW-IMPEDANCE BALANCED MICROPHONES

The amplifier is designed for direct connection of low-impedance balanced microphones to the screw terminal strips on the rear panel. The microphone lead should be a two-conductor shielded cable. Connect the cable shield to the GND terminal.

### CONDENSER MICROPHONES

To supply power for condenser microphones, connect the jumper as indicated in Note 3 on the schematic diagram.

#### Note

*When phantom power is enabled, power is supplied to all five microphone inputs (does not affect AUX inputs); therefore, use condenser microphones only when using phantom power.*

### REMOTE CONTROL PRECEDENCE

Precedence circuits are available to mute MIC 4/AUX 1 and/or MIC 5/AUX 2. A customer-supplied SPST switch with normally-open contacts is required for this function and is connected to the desired REMOTE CONTROL PREC terminals on the rear panel.

### REMOTE VOLUME CONTROL

The Bogen RVC-CTS accessory provides remote volume control of the overall output of the amplifier. Connect the accessory to the REMOTE CONTROL PREC terminals labelled MASTER.

### AUX 1 AND AUX 2

Front panel switches are provided to select MIC 4 or AUX 1 operation and MIC 5 or AUX 2 operation. The AUX inputs use standard Hi-Z phono jacks and accept input from a high-level source such as a tuner, cassette-tape player, WMT-1A telephone line-matching transformer, or tone generator. Use single-conductor shielded cable terminated in an RCA phono plug for connecting auxiliary equipment.

## TECHNICAL SPECIFICATIONS

### Power Output:

*CTS-1035* — 35W RMS

*CTS-1060* — 60W RMS

*CTS-1100* — 100W RMS

**Distortion:** Less than 1% at RPO, 50Hz to 15kHz

**Frequency Response:** 20Hz to 20kHz,  $\pm 1$ dB

**Sensitivity (for full output):**

*AUX* — 0.15V

*MIC Lo-Z (balanced)* — 0.35mV

**Hum and Noise (20Hz to 20kHz):**

*AUX input* — 70dB below rated output

*MIC input* — 60dB below rated output

**Inputs (impedance):** 5 Lo-Z balanced MIC; 2 Hi-Z AUX jacks (switch-selected); 500/600-ohm line input with WMT-1A; Precedence control of MIC 4/AUX 1 and MIC 5/AUX 2; MASTER remote volume control with RVC-CTS accessory

**Outputs (impedance):** 500/600-ohm line output (with accessory transformer WMT-1A)

*CTS-1035* — 8-, 16-ohms, 25VCT (4.5-ohms), 25V, and 70.7V (140-ohms) balanced or unbalanced lines

*CTS-1060* — 8-, 16-ohms, 25VCT, 25V and 70.7V (82-ohms) balanced or unbalanced lines

*CTS-1100* — 4-, 6-8-, 16-ohms, 25VCT, 25V (6.25-ohms), and 70.7V (40-ohms) balanced or unbalanced lines

**Input/Output Connectors:** Screw terminal strips for MIC, speaker and precedence connections; Hi-Z standard phono jacks for AUX inputs, TAPE OUT, PWR AMP; WMT-1A output; provision for WMT-1A input

**Controls:** MIC 1 through 5; switch-selected MIC 4/AUX 1 and MIC 5/AUX 2; MASTER volume; 10 Equalizer Filter Slide Controls; POWER (lighted) Switch

**Equalizer Filters:** 10 filters centered at preferred ISO center frequencies of 80, 125, 200, 315, 500, 800, 1250, 2000, 3150, and 5000Hz; Boost/Cut  $\pm 12$ dB

**Power Consumption (120V, 60Hz):**

*CTS-1035* — 0.9A, 98W

*CTS-1060* — 1.6A, 170W

*CTS-1100* — 2.5A, 250W

**Line Fusing (resettable circuit breaker):**

*CTS-1035* — 1A

*CTS-1060* — 1.6A

*CTS-1100* — 2.5A

**Cabinet Dimensions:** 3-1/4"H x 16-1/4"W x 10"D  
(9.5 x 41.3 x 25.4 cm)

**Shipping Weight:**

*CTS-1035* — 16 lbs. (7.3 kg)

*CTS-1060* — 18 lbs. (8.2 kg)

*CTS-1100* — 20 lbs. (9.1 kg)

## OUTPUT CONNECTIONS

### SPEAKERS

Speaker systems are connected directly to the speaker output terminals on the rear panel of the amplifier. Connect one speaker lead to the COM terminal and the other to the terminal corresponding to the impedance of the speaker system, as shown in Table 1. Class 2 wiring may be used.

### TAPE OUTPUT

A tape recorder may be driven from the TAPE OUT jack on the amplifier. In this case, the output is not subject to the MASTER volume or equalizer filter settings, and is controlled at the tape recorder. A patch cord terminated in a standard phono plug is connected between the TAPE OUT jack on the amplifier and the input of the tape recorder.

### DRIVING A POWER AMPLIFIER

The amplifier may be used to drive a power amplifier. Connect a patch cord with a standard phono plug from the PWR AMP jack on the amplifier to the input of the power amplifier. The output at this jack is controlled by the MASTER volume and equalizer filter controls.

### WMT-1A OUTPUT

Refer to Accessories Section.

### ACOUSTIC EQUALIZER

The Acoustic Equalizer permits you to "tune" the amplifier to the room in which the sound system is used, so that the amplifier can operate at a higher output before acoustic feedback occurs. Ten slide controls boost or attenuate the output at preferred ISO center frequencies — 80, 125, 200, 315, 500, 800, 1250, 2000, 3150, and 5000Hz — to compensate for varying room acoustics.

Microphone placement may also cause feedback or howling at or near some of these frequencies. If so, feedback can be greatly attenuated by setting the slide control for that particular frequency.

## ACOUSTIC EQUALIZER FILTER ADJUSTMENT

**MICROPHONE SOURCE:** The following adjustments of the slide filter controls will permit "tuning" the system so that the output level is substantially higher before acoustic feedback occurs.

1. Set the MIC controls and MASTER control to zero.
2. Set all slide controls to center (flat) position, with speakers connected to the amplifier and microphone(s) in normal operating location(s).
3. Turn the appropriate MIC volume control halfway up, leaving the other MIC volume controls at zero.
4. Advance the MASTER control slowly until feedback ("ringing" or "squeal") is heard.
5. If the feedback sound is high-pitched, one of the five high-frequency filter controls — 800Hz to 5000Hz — will be most effective in its elimination. Likewise, a low-end tone will be controlled by a low-frequency filter.
6. Individually, move each filter control slowly from the center position to bottom and back to center while listening for a change in feedback. The control which eliminates feedback with the least movement should then be moved down only as far as is necessary to eliminate the feedback.
7. Having eliminated the first feedback condition, slowly increase the MASTER control until feedback is heard again. Repeat the procedures of steps 5 and 6.
8. If the position of the microphone is changed, or if additional microphones are used, some adjustment to these controls may be necessary.
9. Output level, reduced because of attenuating one frequency, may be partly restored by boosting the adjacent frequency filter control toward maximum.

If feedback is not a problem, the controls should be used to improve the voice quality and intelligibility of the paging system. In most cases, the 80Hz control should be placed in minimum posi-

tion while the 2000, 3150 and 5000Hz controls should be moved toward maximum for improved response. Each system, depending on the speakers used and room acoustics, will require some experimentation with the controls for optimum results.

## OPERATION

### POWER

The front panel POWER switch applies power to the amplifier. An integral pilot lamp illuminates to indicate that power is on.

### MIC VOLUME

The five individual MIC volume controls are used to adjust the level of each microphone input. Turn the control clockwise to increase the volume and counterclockwise to reduce volume.

### AUX VOLUME

When the MIC 4/AUX 1 or MIC 5/AUX 2 switches are placed in the AUX position, the auxiliary inputs are selected and are controlled with the MIC volume controls. Turn the control clockwise to increase volume and counterclockwise to reduce volume.

### MASTER

This control is used to regulate the overall volume of the amplifier, which may include the output of two or more input channels. To set this control, rotate it to the center position, then set the individual MIC/AUX controls to the highest level likely to be used. Adjust the MASTER control to the desired listening level for the mixed output.

## ACCESSORIES

### WMT-1A LINE-MATCHING TRANSFORMER

The Bogen WMT-1A line-matching transformer provides an impedance match between the amplifier and a 0-level, 500/600-ohm line. This may be a telephone line connected to the switchboard for internal paging or used with a wired music system. No soldering is required to connect the WMT-1A to the amplifier.

**To connect the input from a balanced 500/600-ohm telephone line:** Connect the input line to the three-screw terminal strip on the WMT-1A. Connect the phono plug on the WMT-1A cable to the AUX 1 or AUX 2 jack on the rear of the amplifier. If these jacks are being used for other sound inputs, the WMT-1A may be connected to one of the MIC inputs (assuming phantom power is not active). To do this, the WMT-1A wiring must be modified as described in the instruction sheet supplied with the WMT-1A.

**To connect the amplifier output to a 500/600-ohm telephone line:** Connect the 500/600-ohm line to the three-screw terminal strip on the WMT-1A. Connect the phono plug on the WMT-1A cable to the WMT-1A (output) jack on the rear of the CTS amplifier.

### RPK-52 RACK MOUNTING KIT

The RPK-52 rack mounting brackets are designed for mounting the amplifier in a standard 19" equipment rack. Remove the eight screws (four from each side) securing the cover. Align three of the holes in each mounting bracket with the corresponding holes in the amplifier cover. Secure the brackets to the cover with the six 3/8" screws provided in the kit. Each bracket has two elongated holes on 3" centers for fastening to the rack.

## MAINTENANCE

### Caution

*There are no user-servicable parts within the amplifier. Have all internal servicing done by qualified service personnel.*

### CIRCUIT BREAKER

If the circuit breaker opens, the pilot lamp in the front panel POWER switch will go out and there will be no output. Set the power switch to off and momentarily depress the red button on the circuit breaker to reset it. Return the power switch to on. If the breaker trips again, have the trouble investigated by qualified personnel.

### THERMAL BREAKER

If the thermal breaker closes, there will be no audio output but the pilot lamp in the POWER switch will remain on. Wait approximately two minutes for the breaker to reset. If the breaker resets and then closes again, investigate the cause of the temperature overload. This may be due to improper connections at the output terminals or to excessive environmental heat with inadequate ventilation. The thermal breaker will close when the temperature at the output transistor heat sink reaches 105°C (221°F) on all models.

### BOGEN SERVICE

We are interested in the maintenance of your Bogen equipment. If you experience difficulty, do not hesitate to ask our advice or assistance. Information can be obtained by writing to: Service Department, Bogen Communications, Inc., 50 Spring Street, P.O. Box 575, Ramsey, NJ 07446.

**TABLE 1 – OUTPUT CONNECTIONS**

Models	Speaker Line	Terminal Connections	Other Connections
CTS-1100	4Ω Unbalanced	4Ω and COM	Close link between COM and GND
	4Ω Balanced	4Ω and COM	Open link between COM and GND
CTS-1035 & CTS-1060	8Ω Unbalanced	8Ω and COM	Close link between COM and GND
	8Ω Balanced	8Ω and COM	Open link between COM and GND
CTS-1100	8Ω Unbalanced	25V and COM	Close link between COM and GND
All Models	16Ω Unbalanced	16Ω and COM	Close link between COM and GND
	16Ω Balanced	16Ω and COM	Open link between COM and GND
All Models	25V Unbalanced	25V and COM	Close link between COM and GND
	25V Balanced	25V and COM	Open link between COM and GND
	25V Balanced, CT Gnd.	25VCT and COM	Connect jumper between 25VCT and GND Open link between COM and GND
All Models	70V Unbalanced	70V and COM	Close link between COM and GND
	70V Balanced	70V and COM	Open link between COM and GND

When communicating with us, give the model and series designation of the unit. Describe the difficulty and include details on the electrical connection to associated equipment. We will send service information if the difficulty appears simple. If the unit requires servicing, we will send the name and address of the nearest Bogen authorized service agency to which you can send the unit for repair.

When shipping the amplifier, pack it well, using the original shipping carton or similar container and filler material to prevent damage in transit. Send the unit, fully insured and prepaid, via UPS or other responsible carrier. The unit will be promptly repaired and returned to you collect (freight prepaid while in warranty).

## REPLACEMENT PARTS

Most components used in the amplifier are available through reputable parts dealers. The parts listed here may be obtained from Bogen distributors, service agencies or directly from the factory. When ordering a part, specify the part number, the model of the unit, and the series designation, which is a letter followed by numbers, printed on the chassis. For parts on the circuit board, also give the component board assembly number, which begins with "45".

When replacing transistors, use those made by the specified manufacturers. Transistors from other suppliers may not be satisfactory.

Schem. Ref.	Part No.	Description
--	45-7379-01	PC Board Main P.C. Board Assy.
C8,13,18,23, 37-39	79-008-033	Cap., Elect., 2.2 $\mu$ F, 25V
C10,14,19	79-008-034	Cap., Elect., 33 $\mu$ F, 25V
C12,17,35	79-008-040	Cap., Elect., 10 $\mu$ F, 25V
C24,25	79-126-058	Cap., Elect., 10 $\mu$ F, 50V
C26	79-008-053	Cap., Elect., 100 $\mu$ F, 35V
C29,30,105, 205,305,405 505	78-008-047	Cap., Elect., 100 $\mu$ F, 25V
C31,32	79-119-015	Cap., Elect., 3300 $\mu$ F, 63V
C103,104,203, 204,303,304, 403,404,503, 504	79-126-055	Cap., Elect., 4.7 $\mu$ F, 50V
D1-4,6,7,12	96-5333-01	Diode, 400prv, 1A
D5,8-11	96-5241-01	Diode, 300prv, 3A
D101-104,201- 204,301-304, 401-404,501- 504	96-5344-16	Diode, Zener, 5.6V
IC1,2	96-5575-01	IC NE5532A
IC3,10	96-5687-01	IC P1501
IC4	96-5441-01	IC 7815
IC5	96-5474-01	IC 7915
IC6-8	96-5488-01	IC LM348N
IC9	96-5489-01	IC LF356N
IC101,201,301, 401,501	96-5751-01	IC SSM2015
Q1,2	96-5213-01	Transistor, 2N5089

Schem. Ref.	Part No.	Description
Q3,4,7	96-5283-01	Transistor, MPSA55
Q5,6	96-5290-01	Transistor, MPSA05
Q8,9	96-5356-01	Transistor, 2SB507E (TIP32A)
Q10,11	96-5466-01	Transistor, 2N6254V (RCA)
Q12,13	96-5466-01	Transistor, 2N6254V (CTS-1100)
R2,4,17-19	77-001-810	Control, 100 kilohms (AUD)
R35	77-007-003	Trimpot, 50 kilohms
R54,55	75-172-820	Resistor, 82 ohms, 1/4W
R56,94,95, 101,102,201, 202,301,302	75-172-100	Resistor, 10 ohms, 1/4W
R61	77-001-812	Control, 200 kilohms (LIN)
R64	77-009-001	Trimpot, 10 kilohms
R110,210,310 410,510	75-172-680	Resistor, 68 ohms, 1/4W
RB	75-172-100	Resistor, 10 ohms, 1/4W
S1,2	81-003-077	Switch, Alco MHS-222-RA
--	16-9308-01	Mica Insulation w/comp.
--	45-7380-01	Comp. Bd. Assy. (Slide Cont.)
C1	79-005-039	Cap., Elect., 1000 $\mu$ F, 16V
R1-10	77-001-859	Slide Cont., 50 kilohms
RY1	90-0216-01	Relay, 12V, SPST, N.O.

### Chassis Electrical Components

CB601	94-0018-02	Thermal Breaker, 105°C
CB602	94-0023-08	Circuit Breaker, 2.5A (CTS-1100)
CB602	94-0023-05	Circuit Breaker, 1.6A (CTS-1060)
CB602	94-0023-03	Circuit Breaker, 1.0A (CTS-1035)
R602,	75-212-393	Resistor, 39 kilohms, 1/2W
R603	75-212-103	Resistor, 10 kilohms, 1/2W
R601	75-413-150	Resistor, 15 ohms, 2W
SW601	81-009-035	Ltd. Rocker Switch, 10A, SPST
T601	83-849-000	Transformer, Power (CTS-1100)
T601	83-848-000	Transformer, Power (CTS-1060)
T601	83-847-000	Transformer, Power (CTS-1035)
T602	83-430-020	Transformer, Output (CTS-1100)
T602	83-429-020	Transformer, Output (CTS-1060)
T602	83-428-020	Transformer, Output (CTS-1035)
--	16-9005-11	Strain Relief
--	82-2222-01	Line Cord

### Mechanical Components

TS605	85-0094-07	8 Pt. Term. Strip w/Link
--	23-6995-03	Front Panel (CTS-1100)
--	23-6995-02	Front Panel (CTS-1060)
--	23-6995-01	Front Panel (CTS-1035)
--	03-0686-01	Knob
--	22-5287-01	Cover, Top
--	16-9335-01	Plastic PC Standoff, 1/2"
--	14-9088-01	Polyethylene Foot

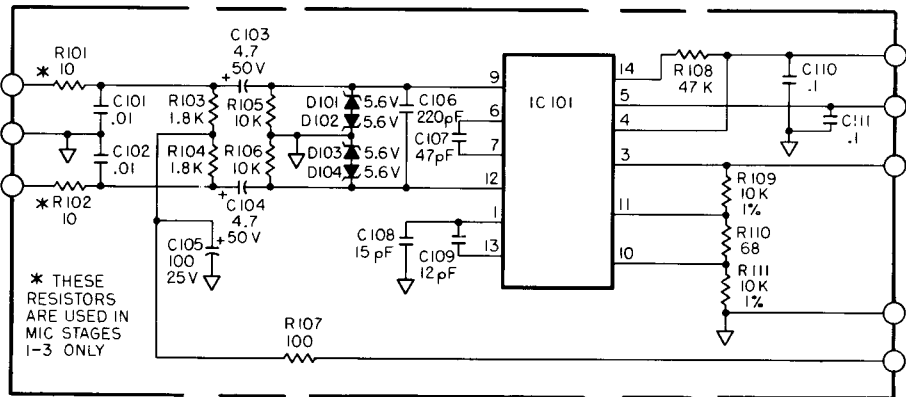
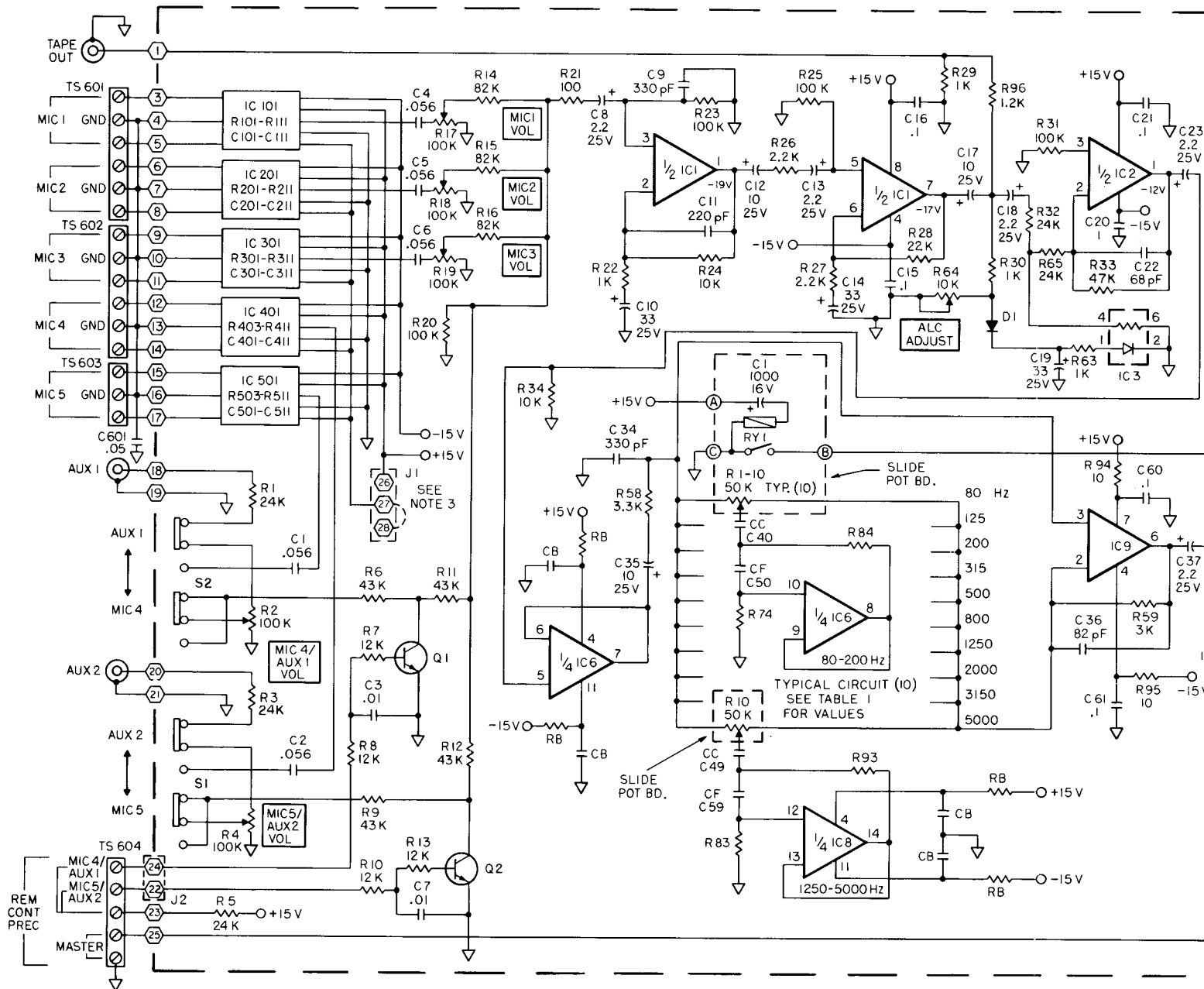

MIC STAGE 1 TYP. (5)

OUTPUT TERM		
MODEL	CTS-1035	CTS-
T 602	83-428-020	83-
GRN/WHT	70 V/140 Ω	70 V
ORN	25 V	
GRN	16 Ω	
YEL	8 Ω	
BLK/ORN	25 VCT/4.5 Ω	25 V
BLK/YEL		
BLK	COM	

MODEL	POWER LINE CURRENT	CB 602 HOLD CURRENT	T 602 POWER XFR
CTS-1035	.9 A	1 A	83-84
CTS-1060	1.6 A	1.6 A	83-84
CTS-1100	2.5 A	2.5 A	83-84

Schematic Diagram — Models CTS-1035, CTS-1060, CTS-1100

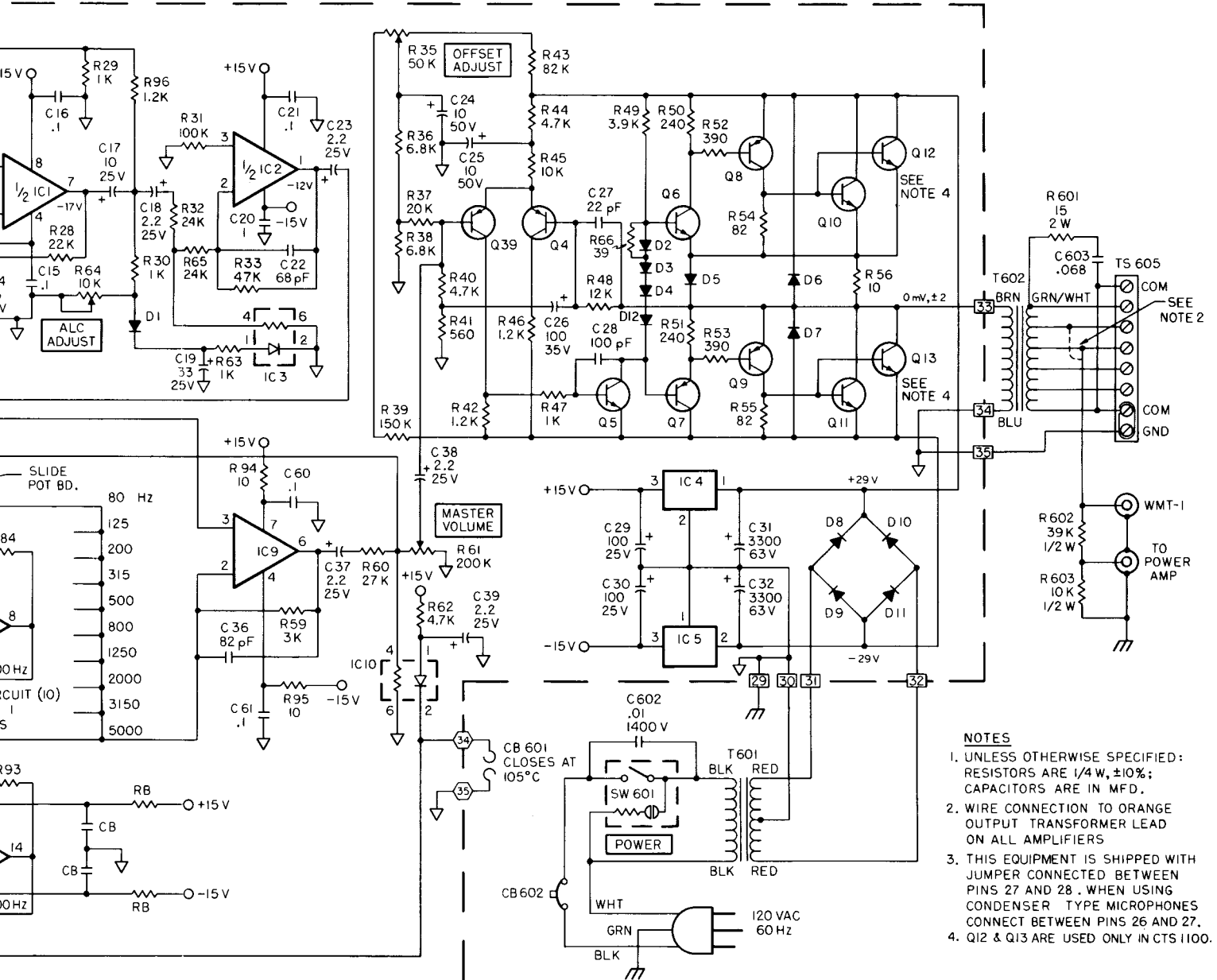

- NOTES**
1. UNLESS OTHERWISE SPECIFIED: RESISTORS ARE 1/4W, ±10%; CAPACITORS ARE IN MFD.
  2. WIRE CONNECTION TO ORANGE OUTPUT TRANSFORMER LEAD ON ALL AMPLIFIERS
  3. THIS EQUIPMENT IS SHIPPED WITH JUMPER CONNECTED BETWEEN PINS 27 AND 28. WHEN USING CONDENSER TYPE MICROPHONES CONNECT BETWEEN PINS 26 AND 27.
  4. Q12 & Q13 ARE USED ONLY IN CTS 1100.

OUTPUT TERMINALS			
MODEL	CTS-1035	CTS-1060	CTS-1100
T 602	83-428-020	83-429-020	83-430-020
GRN/WHT	70V/140Ω	70V/82Ω	70V/49Ω
ORN	25V	25V/16Ω	25V/6.25Ω
GRN	16Ω	16Ω	16Ω
YEL	8Ω	8Ω	—
BLK/ORN	25VCT/4.5Ω	25VCT/26Ω	25VCT/1.56Ω
BLK/YEL	—	—	4Ω
BLK	COM	COM	COM

TABLE I CTS FILTERS 2/3 OCTAVE											
FREQ Hz	CC	MFD	CF	MFD				RB	CB	IC	
F1 80	C40	2.2	C50	.047	R74	68K	R84	510	10	.1	
F2 125	C41	1.5	C51	.033	R75	68K	R85	470	10	.1	
F3 200	C42	1.0	C52	.022	R76	68K	R86	470	10	.1	
F4 315	C43	.68	C53	.012	R77	68K	R87	470	10	.1	
F5 500	C44	.39	C54	.0082	R78	62K	R88	470	10	.1	
F6 800	C45	.22	C55	.0056	R79	68K	R89	470	10	.1	
F7 1250	C46	.15	C56	.0033	R80	68K	R90	470	10	.1	
F8 2000	C47	.1	C57	.0022	R81	68K	R91	470	10	.1	
F9 3150	C48	.056	C58	.0015	R82	68K	R92	470	10	.1	
F10 5000	C49	.047	C59	680pF	R83	62K	R93	510	10	.1	

MODEL	POWER LINE CURRENT	CB 602 HOLD CURRENT	T601 POWER XFMR
CTS-1035	.9A	1A	83-847-000
CTS-1060	1.6A	1.6A	83-848-000
CTS-1100	2.5A	2.5A	83-849-000

E 74-6344-01