



Telecenter® IV Interconnect Planning

RAULAND-BORG CORPORATION • 3450 West Oak-ton Street, Skokie, Illinois 60076-2951 • (708) 679-0900

Table of Contents

Page

Introduction	1
Survey of TCIV System Requirements	2
Survey of TCIV-PBX System Requirements	4
E&M Specifications	6
FCC Requirements	7
Call Answering Devices and Direct Inward Line Selection Criteria	8
Call Answering Device Implementation Data Sheets	
Call Control Console TC4400	10
Key System Unit (Electra-mechanical and Electronic)	11
Electronic Key System Evaluation Procedure.....	12
Private Branch Exchange (On-premise PBX)	13
PBX-TCIV Interface Functions Reference Table	14
Interconnect Layout Drawings (overview)	15
TC4400 to Centrex	16
Administrative Phones to Central Office	18
Key Phones to Central Office	
MI (Day-time set-up)	20
AAI (Night-time set-up)	23
Private DIL Lines	24
Administrative Phones to PBX (DISA)	26
In-Service Training Procedure	29
Telco Installation Planning Guide	30
Emergency Power Failure Changeover	31
Keep-Alive Process	32
Remote Hook-Flash Procedure	33
Interconnect Ordering Checklist	34
Traffic Handling Requirements	35
Traffic Capacity Worksheet	38

Introduction:

This manual is for use in planning the interconnect portion of a Telecenter IV Communications System. It provides fully explained examples of interconnect system configurations as aids in system design as well as a procedure for ensuring adequate trunk capacity. Use this manual in conjunction with KI-1581, the Internal System Planning Guide; KI-1584, the Programming Procedures; and the Glossary of Terms in KI-1587, Drawings and Data.

warning: Do not attempt to plan an interconnect system without fully understanding how to obtain the features available through system programming.

If the TCIV will not be connected to an on-premise PBX, go to the Survey of TCIV System Requirements; otherwise, go to the Survey of TCIV-PBX System Requirements.

Survey of TCIV System Requirements

Summary: Get a general view of the interconnect and communication problems to be addressed by the TCIV system at this location and a full picture of the current system. Obtain data on the numbers and types of stations and trunks in the present and required system. If planning for a new construction project and there is no site to visit and little information available, try visiting a similar organization in the same district. Then, make a point of repeating the survey on-site before the actual installation: at that time, make any changes required to ensure the system design will meet the customer's requirements.

Note: This procedure is for a system supported fully by the TCIV. **A separate survey** procedure is provided for systems where a PBX will handle most of the incoming traffic (Survey of TCIV-PBX System Requirements).

Step 1. Determine which of the following cases best describes the office situation where incoming calls are to be answered and if it is representative of how the customer wants to operate.

Case 1.

The primary task of answering incoming calls, at least during the busy hour, is assigned to one person (the attendant or operator) who will transfer most calls to appropriate administrative stations. Answering calls and transferring them is this person's job and little time will be spent handling calls in any other fashion.

A few people may be available to help answer incoming calls when necessary; however, it is desired that the call answering system be efficient enough not to restrict the main attendant from quickly answering and transferring calls.

case 2.

No attendant is assigned. Instead there are 3 to 6 people in the office capable of answering and handling most calls directly. During the busy hour there will be enough people to handle all of the calls as long as they have the ability to occasionally put someone on hold. Any one of these people can easily pick up on any call. Transferring a call is a fairly infrequent requirement.

If case 1: A TC4400 Call Control Console is indicated. However, a KSU may work satisfactorily if the maximum rate of answering incoming calls does not exceed 20 to 30 per hour for any individual and transfer-target extensions are seldom busy.

If case 2: A KSU approach may provide the best solution.

Step 2. Estimate the maximum number of incoming calls expected during any one hour of the day or week:

Maximum Expected Calls/hour = _____

Step 3. **Determine** how many administrative phones are required and the number which will have access to outside lines:

Administrative **Phones With Access:** _____

Total Administrative Phones: _____

- Step 4. **Determine if the** number of current or planned general purpose Central Office trunks (excluding DIL trunks dedicated to private lines) in the system will exceed 10. If so, system requirements may exceed TCIV traffic handling capacity.
- Note: **Use the Traffic Handling Requirements** procedure provided in this manual to make this determination. (General purpose Central Office trunks are those used for answering incoming calls and are shared by administrative phones placing outside calls.)
- step 5. **If the** new system will have significantly more outgoing traffic than the previous system, increase the trunk requirements accordingly.
- Step 6. If the trunks are Centrex type and it will be necessary to make transfers within the Centrex system, special **training will be required** for using the built-in remote hook-flash signal of the TCIV or the TC4400 Console (refer to the In-Service Training and Remote Hook-Flash sections of this manual).
- Step 7. **Determine** what wiring and station equipment from the original system will be usable in the TCIV.
- Step 8. If the local Central Office does not provide tone dialing service, **obtain** a convertor for each trunk line.
- Convertors Required:** _____
- Step 9. Refer to the Ordering **Checklist** (following the Interconnect Layout Section) and ensure all hardware requirements are met.

Survey of TCIV-PBX System Requirements

Summary: Special considerations are required when planning systems which interface with a **Central Office through** a PBX. These include: the number and type of PBX lines which will interface with the TCIV; TCIV feature restrictions which may result from the type of interlace; programming requirements; and, additional hardware to compensate for combined TCIV and PBX line losses. Other considerations include variations in transfer procedures and visual indications available to the PBX attendant for transferring calls to TCIV stations.

Step 1. **Determine the** number of extensions required for people mainly involved in internal communications, paging, and other TCIV functions: Assign these extensions to the TCIV.

TCIV extension8 _____

step 2. **Determine the** number of extensions required for people who mostly communicate with the outside world: Assign these extensions to the PBX.

PBX extensions _____

Step 3. To support traffic between the TCIV and PBX, **determine the** number of E&M (Ear and Mouth), Modified TC4171 COA, and/or PBX Extension Line interfaces needed to meet customer requirements:

E&M Interface

If extensive use of the TCIV by PBX extensions is planned, a two-wire E&M trunk is the preferred interface between the PBX and TCIV because it:

Enables TCIV extensions to hold the PBX and PBX extensions to hold the TCIV without using the keep-alive process.

Eliminates timing problems associated with using ring voltage to signal the start and stop of service requests between systems.

If an E&M interface is implemented, it must:

- Meet the E&M **Specification** requirements provided in this manual.
- Be built and installed in accordance with KM0930.
- Be programmed to accept a remote service request (**B:8 ON**).

Modified COA Interface

If the remote system provides a disconnect-break signal (described below), **this type** of interface can be used to achieve functional performance similar to an **E&M** interface.

Contact the owner/vendor of the remote system to see if it can provide the disconnect-break signal or check for the signal using an LED wired in series with a phone. If it is present, the LED will go off for 0.5 to 1.0 second within 10 seconds after the remote extension hangs-up. If a COA is connected, the CO LED will provide the same indication.

If the disconnect-break signal is present, contact Sales Engineering for informaiton on modifying the TC4171 COA. The COA may be modified for this application because FCC Part 68 does not apply to TCIV-to-PBX interconnections.

PBX Extension Line Interface

If only a few PBX extensions will use the TCIV, spare PBX extensions lines may be used for interconnecting the two systems; however, the following limitations make this the least preferred type of interlace.

The keep-alive process must be used by PBX extensions to hold the TCIV until an off-hook TCIV extension enters the connection.

When ringing is used to indicate the start and stop of a service request to the TCIV, a time & lay is needed to distinguish between a normal ring pause and a termination of the ring (i.e.: service request).

If PBX extensions cannot send tone signals to one another, this type of interface will not allow PBX extensions to use the functions of the TCIV.

step 4. Note the number of each type of interlace required in the spaces below. Normally only one type will be used.

Two-Wire E&M _____
Modified TC4171COA _____
PBX Extensions _____

Step 5. Determine if the PBX can provide its extensions with single-digit access to a group of TCIV-to-PBX interconnect lines.

Single Digit Access: **YES** ____ **NO** ____
Auto Hunt Group: **YES** ____ **NO** ____

Step 6. Determine the PBX access digit or digits used by PBX phones to obtain outside dial-tone.

PBX Access Digit _____

step 7. Refer to the Ordering Checklist (following the Interconnect Layout Section) and ensure all hardware requirements are met.

E&M-Interface Specification (TCIV-to-PBX)

Summary: E&M interfaces are available from various manufacturers in a variety of types with several options. The following specification defines the type of E&M interface which will work most effectively with the TCIV. Refer to drawing KM0930 (in KI-1587) while reviewing the following specifications.

Specifications:

1. The interface shall be facilitated by two twisted-pairs (T&R and E&M) and a ground wire. It shall provide a ground terminal for connection to pin Z (0 volts) on the TCIV Main Input/Output (MIO) board.
2. The PBX T&R (Tip and Ring) leads shall present a low-loss audio path (nominally 600 to 900 ohms impedance) to the T&R of the assigned TC4150 Line Link Module (LLM) circuit.

The T&R shall be transformer-isolated and free of any other signalling (e.g., ring voltage and loop current).
3. The M-lead shall be an output from a relay or solid-state contact capable of blocking + 12 Vdc until it is activated to provide a ground to the TCIV, at which time it may conduct up to 100 milliamperes d.c. current.

The M-lead is an output, sometimes referred to as the mouth lead. It tells the other system that service is required. The M-lead from one system shall be connected to the E (Ear) lead of the other system.
4. The E-lead voltage shall be in the range of -48 Vdc to +48 Vdc. When grounded, the E-lead current may not exceed 50 milliamperes dc across a loop resistance of up to 150 ohms. Additionally, the E-lead shall be internally voltage limited to eliminate transients outside the +/- 48 Vdc range.

The E-lead shall receive a service request from the TCIV M-lead. This service request will cause the PBX to give dial-tone and audio communication service. Whenever the ground on the E-lead is released, the PBX will cancel service and disconnect.
5. Dial-tone shall be supplied to the TCIV when service is requested by the TCIV (ground on the E-lead). This shall enable the TCIV extension to have access to all features normally available to a PBX extension, including hook-flash detection (the E-lead ground is interpreted as an off-hook signal).

Any PBX extension connected to the TCIV through the interface shall be able to send any of the 12 DTMF tones to the TCIV at any time. With the exception of TCIV-to-TCIV transfers, which require a hook-flash, this shall enable the PBX extension to have all capabilities of a normal TCIV extension, including paging and phone-to-speaker communication and they shall not have to use the keep-alive process.
6. If PBX users require singledigit access to multiple TCIV-PBX trunks, the PBX shall provide both auto-hunting for an idle trunk and single-digit dialing. (Both capabilities are built-in to the TCIV but are not available as either standard features or options on some PBX lines.)
7. The E&M Protocol demands that the originator of a service request shall be responsible for breaking the connection once the requirement for audio service is ended.

A service request originated by the M-lead of either the TCIV or PBX shall be followed by a complementary M-lead signal from the interfacing system when audio service becomes available from that system. Depending on programming, audio service may be either dial-tone or connection to an off-hook extension.

Flash signals shall not be acknowledged as service requests via the interface but shall obtain a new dial-tone and appropriate transfer services.

FCC Requirements

- Summary:** Rauland-Borg's Model TC4171 (COA Module) conforms to the requirements of the Federal Communication Commission's Rules and Regulations, Part 68, which governs the connection of circuitry to protect the telephone network. The user must be aware of the requirements pertaining to the installation and the operation of this protective device. The rules are summarized below; the complete current rules will be in the current copy of the FCC's Rules. All of the pertinent rules must be followed.
1. The TC4171 (COA) should only be connected to a standard subscriber line via the proper coupler installed by the telephone company; it should never be connected to a party line or coin line.
 2. You must give the local telephone company:
 - a. notice that you want to install an FCC-approved device to their line (similar notice is required of a final disconnect).
 - b. the registration number and the ringer equivalence, which are marked on the compliance label, and
 - c. the connection required for the TC4171 (COA), the RJ21X, RJ11C, or RJ11W (see this manual, M-1582, the installation manual, IU-1583, and wiring diagrams KM-0714 and KM-0716).
 3. Once the telephone company has installed the proper connector, insert the plug coming from the TC4171 wire-wrap terminals.
 4. No repairs may be made to the TC4171 (COA) or to the TC4001 (main central assembly) while the TC4171 is connected to the phone line. If any malfunction occurs on this interconnect device or with the TC4001, disconnect the TC4171 and replace it with a unit known to be operating. If the Telecenter equipment is adjudged to be operating properly but the problem still exists, contact the telephone company. Reconnect the phone system only after determining that this equipment is not the source of the malfunction.
 5. If the TC4171 (COA) should cause harm to the telephone network, the telephone company is required, where practicable, to notify you that temporary discontinuance of service may be required. If advance notice is not practicable, the telephone company is permitted to discontinue its service immediately, provided that such an action is reasonable under the circumstances. In the case of temporary discontinuance, the telephone company is required to:
 - a. Promptly notify you of the temporary discontinuance.
 - b. Give you the opportunity to correct the situation that caused the discontinuance.
 - c. Inform you of your rights to bring a complaint to the FCC pursuant to the procedures set forth in that agency's Rules. Copies of the procedure for making a complaint can be obtained from Rauland-Borg.
 6. The telephone company can make changes in its facility, operations, equipment, or procedures, provided that the changes are reasonably required and are consistent with the FCC's regulations. If these changes render the customer's equipment incompatible or require that it be modified, the telephone company is required to give sufficient advance notice in writing to allow the customer the opportunity to maintain uninterrupted service.
 7. Do not modify, repair, or alter this registered interconnect device, the TC4171 (COA): any such actions will void the warranty and could result in discontinuance of service from the telephone company. If the TC4171 requires service, return it to the Rauland-Borg Corporation.

Call Answering Devices

Summary:

Any Interconnected system requires a method for answering and transferring calls. Four options exist for centralized call answering: One or more Attendant Phones, the **TC4400** Call Control Console, an Attendant Key System, or a separate PBX. The choice depends on the business environment identified when performing the Survey **of TCIV (or TCIV-PBX) System Requirements** and the **Traffic Handling Requirements** sections of this manual, as well as a variety of economic considerations.

Call Answering Device Selection Criteria

Use stand-alone one-, two-, or three-line phones as the primary means of answering outside calls only in smaller systems with low traffic requirements.

Review the following section on using DIL trunks and then refer to the Call Answering Device Implementation Data Sheets to determine which will best meet the unique site requirements.

Call Answering Device	Implementation Data Sheet
TC4400 Call Control Console	1 of 3
Key System Unit (KSU)	2 of 3
Private Branch Exchange (PBX)	3 of 3

Direct Inward Lines (DIL)

DIL trunk lines can be used alone or to modify incoming-call answering service for each type of call-answering device. DIL trunks are generally grouped together and adjacent to other trunk groups. When the TCIV senses an incoming call on a DIL trunk, it rings the owner administrative phone line.

DIL trunks are designed to look like private lines to a remote system (i.e., someone on the outside dials a normal seven-digit number and the central office sends a ring signal to the TCIV which then rings the owner administrative phone). When the call is answered, the TCIV answers the trunk and connects it to the administrative line through one of the sixteen links. To the outside caller, the TCIV is transparent and the call seems to go directly to the private line. However, since the connection is made through the TCIV, the administrator has the ability to transfer the call to any other TCIV extension. Also, since the administrator is connected to the TCIV, paging and internal communication functions can be performed with the same instrument.

Private DIL

In many cases DIL owners always use their own DIL trunks when placing outgoing calls. When this is done, by turning the B:3 **attribute on**, the line is inaccessible to other outgoing callers. This configuration allows a busy signal to be given whenever callers from the outside attempt to call the DIL owner when he/she is involved in an outside call. Also, the owner's DIL line is always available, even when all other trunks are in use. The DIL owner can only be blocked from dialing out when all trunks are busy and he/she has already transferred an outside call to another internal station.

Public DIL

If a DIL trunk is made public, by turning the B:3 **attribute off**, anyone may use it who is authorized to place outgoing calls. If public DIL trunks are organized in a normal hunt group with dial 9 access for outside calls, the first one tried will tend to be busy most of the time and incoming DIL calls will be blocked. The circular hunt described in XI-1584 (Programming) may be used to prevent this. However, it is preferable to configure DIL trunks as private.

DIL Access

It is possible to enable dial 9 access for all outside calls and still have DIL owners get their own lines. Group private DIL lines (B:3on) in front of the other trunks (i.e., at lower physical numbers) and set the hunt bit on each trunk. Then, the TCIV will always hunt for an outside line through the private DIL trunk group first, giving DIL access to owners but not to others.

Busy DIL

If the DIL trunk owner's extension is busy when the TCIV senses an incoming call the TCIV cannot answer the call because it cannot be put through to the owner. The TCIV provides two programmable options for handling this situation:

Send the call to the attendant line so a message can be taken or a page made (B:7 OFF).

Do not respond to the call until the DIL owner hangs-up **and becomes** available (B:7 ON).

Note: Complaints about unanswered ringing may arise **if the** call is not sent to the attendant and is ignored by the system. Outside callers will continue to hear ringing until the line becomes available and is answered.

Auxiliary DIL

DIL trunks may be used to optimize system configuration when a centralized call answering device is used to handle incoming calls as described below.

Answering Device Suggested DIL Configuration and System Operation

TC4400, KSU or PBX	Provide DIL trunks for private lines listed in the public telephone directory.
TC4400 or KSU	If a separate night-time set-up requires assigning different trunks and outside numbers to various stations (e.g., Gymnasium, Music Room, etc.), use the TCIV's double EEPROM with an external day/night switch to convert some AAI trunks to DIL trunks at night (see KM0896).
KSU	If it is necessary for the attendant to distinguish between outside lines or if several key-phone attendants are responsible for answering certain lines, wire each DIL trunk directly to a specific key phone line. Using the configuration described above, restrict keys associated with DIL lines to incoming traffic only and provide separate keys for calling out.
PBX	If the PBX attendant must make frequent transfers to a specific TCIV station, use a DIL trunk wired through a TC4171 Central Office Adapter (COA) between the PBX and TCIV. When the PBX rings the extension connected to the COA, the TCIV will ring its station: When the TCIV station goes off-hook to the COA, it will simultaneously appear off-hook at the PBX. This can improve some attendant operations because a DIL trunk functions more like an extension than a DISA trunk.

Implementation Data Sheet 1 of 3

TC4400 Call Control Console

Summary: The TC4400 provides twenty keys which allow simple and efficient handling of multiple inside and outside calls as well as performance of those TCIV functions normally handled by any administrative or display phone. It is the recommended call answering device for the following reasons:

The TC4400 attendant can handle 200 calls per hour, whereas a Key System attendant can only handle about 30 calls per hour.

The TC4400 attendant can dial into the TCIV without waiting for dial tone or receivers because it does not require a DTMF receiver or a line when handling and transferring calls.

The TC4400 has twenty (20) direct-select keys for use in answering, placing, and transferring calls. Each key has a red LED and a green LED to differentiate between line related console activities (red) and non-console related line activity (green). The keys may be divided into **three groups:**

Trunk Lines: Up to ten (10) keys may be programmed for trunk (AAI) lines for handling and placing outside calls.

Telecenter: These keys are used for handling call-ins from speakers, switches, and non-dialing phones, operator (0) calls from dialing phones, and making inside calls or performing other TCIV functions.

Monitoring: Keys may be programmed for monitoring specific extensions which normally are administrative line but may include both non-dialing phones and speaker-and-switch lines. Dialed Operator calls from monitored extensions (not call-ins) come to the associated Monitored Extension key rather than to a Telecenter Key.

The TC4400's ability to maintain the identity and status of specific trunks is especially helpful when OPX, Centrex, or Watts lines are used or when a problem occurs with a particular trunk.

The TC4400's built-in VFD (vacuum fluorescent display) shows Call-ins, system functions, and provides operator prompting. Whenever a call is detected, an electronic beep sounds and continues until the call is answered or cancelled. beeps do not sound when the attendant is talking on the console.

While only one TC4400 can be used in a system, administrative phones can be used to remotely answer and handle calls when the operator is either not present or must spend more time with some callers.

Implementation Data Sheet 2 of 3

Key System Unit (KSU)

Summary: The TCIV main program can systematically route calls to a specified small group of lines where they can be answered using a Key System. TCIV software and hardware are designed to work with an electromechanical KSU as the answering device and has been tested with some electronic KSU's (EKSU). The advantages and limitations of KSU's are provided below and EKSU's are on the following page.

Electromechanical KSU with K400E ITT line cards.

Allow incoming call handling tasks to be shared by several people without designating anyone as attendant.

Require little operations training because they are familiar to most people.

Are standard telecommunications products available from multiple manufacturers at reasonable cost.

Allow flexible configuration of key equipment.

Do not provide the advanced features of an electronic key system unit (EKSU).

Rack mounted KSU by Plant Equipment Inc.

Supports 8 lines on a nine line key phone with the extra key serving as a disconnect.

Different keys may be programmed for different types of calls: (i.e.: outside calls to keys 1, 2, 3, and 4; recalls to keys 5 and 6; operator calls to key 7; and, key 8 for the executives line.)

Allows operator tasks to be shared through several identical instruments.

Use K400E line cards and a TC4172 Adapter which provides 25 pair connectors for direct plug-in of key phones. Phones can be located further from the rack by using standard 25 pair extension cables (see Manual KI-1491 for data on the TC4172 Adapter Card).

Must be special ordered for a 19 inch (rather than a 24 inch) rack. If supplied to Rauland-Borg by the distributor, these units may be factory installed and wired.

Electronic Key Systems.

Provide special features, such as: auto dialing, speaker phone, privacy, etc.

Must be tested (see EKSU Evaluation procedure) to ensure compatibility with the TCIV and system requirements, unless already approved (e.g.: AT&T Merlin ®).

KSU Ahead: A KSU (but not an EKSU) can be installed so that incoming and outgoing calls do not enter the TCIV system unless transferred to it. This makes transfers more complex but: allows monitoring of all calls in and out of the TCIV; eliminates "Dial-9" for outside access by key-phones; allows the KSU attendant to break into a trunk to TCIV connection as if breaking into the line of another key phone; and, enables keys to maintain trunk identity.

EKSU Evaluation: (continued from Implementation Data Sheet 2 of 3)

Summary: Select an EKSU from a reliable manufacturer and use at least two and preferably three key stations to evaluate it according to the following criteria before specifying it as part of a TCIV system. Certain functions may be of no importance in one application and be essential in another. Evaluate those which are necessary and take care to include any which may be desired during future system development.

EKSU Support: Dozens of manufacturers produce EKSUs, however, regardless of the supplier, it is advisable to have a spare system on the shelf before installing one because:

Suppliers are legally required to provide parts only (not replacement systems or stations) for 7 years; therefore, parts (and possibly repairs) are all that can be expected.

The quality of customer service varies widely; some manufacturers fail to maintain a proper stock of spare parts or have extremely long ordering lead-times. Additionally, service information is often of poor quality and rarely includes schematics.

The industry is volatile and unpopular systems are often discontinued and a poorly managed manufacturers may go out of business or bankrupt.

Verify the following operations can be performed successfully:

Caution: What works in one system may not work in another. The only way to be sure is to test it. Don't bank on hear-say evidence.

- * Two EKSU stations can talk on the same line with a third party (an outside line through the TCIV) on a conference call.
- * The EKSU repeatedly functions appropriately in response to the TCIV's double ring indication for incoming trunk calls.
- * The EKSU can be answered at any time during incoming ringing from the TCIV. This test will require the use of a meter to ensure calls can be answered without problem at any period of the TCIV ring cycle.
- * The EKSU can place a TCIV line on-hold at one EKSU station and the line can be picked-up at another EKSU station.
- * At least a 25 ma loop current is maintained with any key-phone line off-hook or holding (see Loop Sense Measurement in KI-1586).
- * Failures do not occur when attempting to talk or hold using the TCIV's 12 Vdc lines. (This is common with 2 and 3 line phones; however, it can be overcome via internal modification on some Comdial units.)
- * EKSU features (call announce, auto dial, speaker phone, privacy, etc.) work correctly.
- * When dialing from the ERSU into the TCIV, each DTMF tone is of sufficient level, duration, and purity to break the TCIV's dial tone.
- * The EKSU can send # and * DTMF tones to the TCIV at any time.

Implementation Data Sheet 3 of 3

Private Branch Exchange (PBX)

- Summary:** If incoming calls are answered by an attendant at a separate PBX which then transfers the calls to the TCIV through interfacing lines, review the PBX remarks in the survey section of this manual to be sure that all pertinent data have been obtained, Then review the following discussion, the PBX-TCN Interface Functions Reference Table, and the Interconnect Layout Drawing section and develop the system design.
- Note:** This discussion concerns systems with a mix of on-premise PBX and TCIV lines. If the TCIV is connected to an off-premise PBX and a KSU or TC4400 is operating as the primary answering device, refer to the Implementation Data Sheet for the devices to be used.
- Limitations:** Interfacing a TCIV through a PBX is the least desirable interconnect configuration. However, due to economic (capitalized investments), functional (combined benefits), or operational reasons (differing departmental needs), it may be required. This type of interconnect is limited because each system has detailed knowledge of only its own extensions, causing increased complexity when users in one system access the other system.
- Options:** If the PBX attendant or extensions should have access to TCIV paging and speaker functions, provide at least one DISA line (E&M or non-E&M). (DIL trunks cannot be used by regular PBX extensions for paging and speaker functions within the TCIV.)
- If non-E&M DISA lines are used and the PBX does not provide an explicit service request, Keep-Alive Process training must be provided to PBX attendants. After dialing into the TCIV, the attendant cannot release until an off-hook TCIV extension is obtained or the keep-alive timeout occurs. Therefore, the PBX attendant may have to respond to the keep-alive while waiting or hang-up and wait for the keep-alive timeout to occur before using the trunk again.
- If some TCIV extensions make and receive mostly outside calls, the PBX may be bypassed with DIL trunks from the central office to the TCIV for their traffic. These trunks may be unlisted or outgoing only for specific extensions (Library, Physical Education, etc.). This will reserve the DISA trunks for incoming use and reduce the attendants call handling load.
- If the PBX operator needs to transfer incoming calls to 2 or 3 predetermined extensions in the TCIV, install DIL trunks between the PBX and TCIV using TC4171 Central Office Adapter Modules (COAs). From the PBX, these TCIV extensions will appear like PBX extension lines. This will allow attendants to handle transfers to these extensions using normal PBX operating procedures (i.e.: dial the associated extension and hang-up when ringing begins), letting the PBX provide an alert (ring-back) if no answer is received.
- Additional Considerations:**
- The PBX and its extensions must be DTMF and the extensions must be able to send tone signals to one another or they will not have access to the TCIV functions.
- The PBX should be capable of one-digit dialing to the TCIV.
- If multiple lines connect the PBX and TCIV, the PBX should automatically hunt for an available line; otherwise, the PBX user will have to dial each line in turn.
- TCIV users with access to the PBX must be trained to use the Remote Hook-Flash Process in order to transfer PBX to TCIV callers to PBX extensions or create PBX-TCIV-PBX conferences.

PBX-TCIV Interface Functions Reference Table

Summary: When deciding the appropriate mix of DISA (E&M and non-E&M) and DIL trunks to provide when designing a PBX-TCIV interconnected system, it is important to determine what features are available and what limitations exist from the user's perspective in the following cases.

The last three cases concern capabilities of the PBX Attendant when performing the stated functions with an extension in the specified system. All other cases relate to the ability of an extension in the specified system to perform the stated functions.

Function	system Where Extension is Connected	
	TCIV	PBX
Paging and speaker communications without using keep-alive process.	YES	NO YES(with E&M)
Different paging and alarm authority levels programmable for different extensions.	YES	NO
Can have prefix restrictions for limited access extensions.	YES	If supported
Outside access can be provided to some extensions and not others.	YES	YES
Can hook-flash the other system to perform transfers within that system.	YES'	NO
PBX Attendant can park a call when transferring an outside call to the specified extension.	NO	YES
PBX Attendant can transfer a call to the specified extension by starting the ringing and relying on recall if no answer.	NO(DISA) YES(DIL)	YES
PBX Attendant has visual indication when the specified extension is busy.	NO**	YES

Notes:

* The remote hook-flash process must be used by TCIV extensions to transfer calls to the PBX.

** Visual indications of busy extensions could be provided with TM432 Graphic Annunciator Modules or special circuits off of the LLMs, given corresponding wiring, power, and Console area mechanics.

Interconnect Layout Drawings

Summary: Example Interconnect Layout Drawings representing the most common system configurations are accompanied by an analysis of each systems Incoming, Outgoing, and Internal Call Handling characteristics. Where appropriate, problems and design alternatives are considered along with their impact on the system.

Interconnect Layout Drawings are excellent system design tools: They may be quickly created and analyzed to determine if a system design is adequate for the job. Their pictorial overview of the major system components makes them useful as reference and maintenance documents.

Each diagram is organized as follows:

The interconnect system is shown as it relates to the Telecenter IV and relevant programming, operational, and physical data is provided for each line and relevant location code according to the following convention:

N: (Architectural Number)

P: (Physical Number)

A., B., and Z: (Line Type Attributes)

Location Code: **Setting:** **Explanation**

Where applicable, extensions are provided with an arrow to show the direction the remote system hunts for available lines. Equipment symbols, quantities, and explanations are provided for each type of line or lines and a floor plan shows the relative location of attendant stations.

Note: Interconnect Layout Drawings require modification as problems are addressed and resolved. Therefore, make them lightly with pencil and show only the details needed for installing, testing, and programming the system using the built-in #73, #98, and #99 functions. Avoid including the in-depth technical details which can be handled by a technician.

Review the following list to determine which Interconnect Layout Drawing(s) most closely suits your needs and then make a similar drawing for your application. Note that these are examples only and a specific installation may require a combination of their various features. After completing the drawing, perform an analysis similar to those presented with the examples. Each system is listed according to its answering device and interfacing system.

Interconnect System	Layout Drawing
TC4400 to Centrex	1 of 6
Administrative Phones to Central Office	2 of 6
Key Phones to Central Office (Day Set-up), AAI Lines	3 of 6
Key Phones to Central Office (Night Set-up), AAI Lines..	4 of 6
Key Phones to Central Office, Private (DLL) Lines	5 of 6
Administrative Phones to PBX	6 of 6

Interconnect Layout Drawing 1 of 6

TC4400 to Centrex

Summary: The Kennedy School shown below in drawing KM0892 is a large system with a TCIV Call Control Console, 8 Centrex trunks, two 2-line phones, 40 administrative phones and 100 speakers. All classrooms have staff phones and speakers for intercom, class change tones, and paging.

Incoming Call Handling:

Normals The TC4400 is used to answer all incoming traffic and route it to other extensions in the system. The TC4400 busy lamp field, direct select keys, and the elimination of any wait for dial tone all combine to enable call handling rates of at least 200 calls per hour. The 8 AAI (A:3) trunks come into 8 keys on the TC4400: line 11 is on the eighth key and line 18 on the left-most key. Since incoming calls are most likely to come in on line 18 first (due to the direction of hunt by the Central Office)

Transfer: The Console may transfer calls using either of two methods: prescreen or non-prescreen. Prescreening takes longer because the operator must talk to the target extension before releasing the call and one more keystroke is required. Prescreening decreases call handling efficiency and may limit the number of incoming calls that the operator can handle during heavy traffic periods.

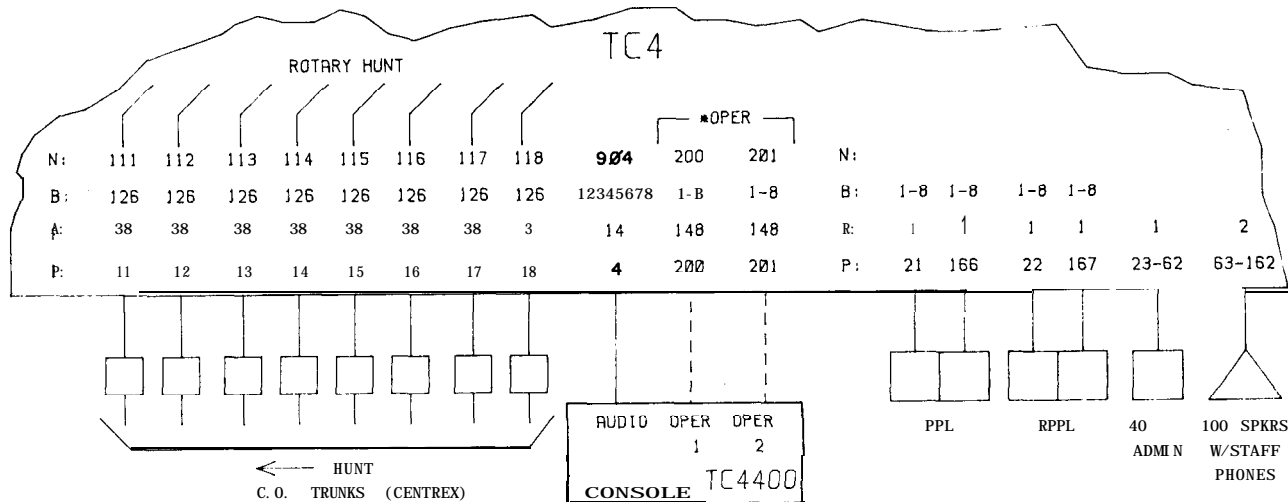

P: MONITORED EXTENSIONS

- 21 PRINCIPAL
- 22 ASST PRINCIPAL
- 23 SECY
- 24 NURSE
- 25 P. E. BOYS
- 26 P. E. GIRLS
- 27 } COUNSELORS
- 28 }
- 29 }
- 30 }

* VIRTUAL LINE ONLY
NO HARDWARE OR WIRES
REQUIRED.

TRAFFIC FLOW:

- CONSOLE HANDLES ALL INCOMING CALLS AND ANNUNCIATOR CALL-INS.
- CONSOLE MAY ELECT TO PERFORM TRANSFERS THROUGH REMOTE FLASH & CENTREX TRUNKS.
- PRESCREENING IS ENABLED.
- DIAL "4" FOR REMOTE ANSW.

INTERCONNECT	LOCC.	CODE
64000	0	ATTENDANT
64016	200	' 0 '
64034	11	'9
64024	4	"4" REM ANSW
64510	9	PBX ACCESS DIG11
64222	0	ATTNDT RECALL
64110	45	REMOTE HOOKLF

TELECENTER IV
KENNEDY SCHOOL INTERCONNECT
CONSOLE-CENTREX
RRULRNO-BORG CORP.
MADE IN U. S. A.
KM0892-A

The TC4400 will handle transfers more smoothly than a Key System because the attendant has direct select keys for the ten busiest extensions (P:2 1 - 30). Each of these keys has a busy indicator which increases operator efficiency by eliminating time wastage associated with attempting to transfer calls to already busy extensions. Additionally, the TC4400 transfer key is always received immediately while a request from a key phone may have to be repeated if presented when both receivers are busy.

As backup for when the operator is unavailable, either one of the two-line administrative phones can pick up incoming calls to the TC4400 by dialing **4** (Location Code **64024**) to remotely answer any trunk or internal caller ringing the TC4400. If needed, the second line can be used for prescreening or paging while the first line temporarily holds the call picked-up. However, using 4 for single digit dialing prohibits the possibility of having extensions which start with the digit "4". Furthermore, this single digit could be accidentally selected. One way around this problem is to set the architectural number of line **4** to **444**.

Outgoing Call Handling:

Note that the PBX access attribute (B:6) is set on all AAI trunk lines. This allows Telecenter extensions to be restricted or blocked even though they are dialing through a Centrex. It also allows any TCIV phone to dial any Centrex extension without having outside access. Authorized phones may make outgoing calls directly by dialing, waiting for Centrex dial tone, and dialing again. Unauthorized phones can get an outside line only by operator transfer.

Administrative outgoing calls progress from right to left across the TC4400 display, the opposite direction from incoming calls. When the console operator dials an outside call one of the two TCIV receiver is required because the TC4400 does not generate dial tones. The console does, however, have priority access to the receivers. If the receivers are both busy, the key strokes are stored in a buffer and are sent when the first receiver becomes available.

Internal Call Handling:

Calls to the operator come to the Console on the first operator key, physical number 200, set at Location Code 64016: Attendant ring-backs to the TC4400 go to the same trunk on which they were originally received. However, while a call from the outside is indicated by a red LED, calls from within the TCIV light both the green and the red LED. Staff call-ins to the TC4400 include an audible beep and are answered using one of the two operator keys plus the * or architectural number of the call

If the Console operator needs more direct select keys, they may be obtained from the trunk keys. For example, the first Eve keys could represent trunks with the last three trunks not visible on the display. This might be acceptable since the last three trunks are, generally, for outgoing calls and therefore not important to the operator. If a call should come in on one of these three keys, the TCIV will send it to one of the Telecenter (Operator) Keys. With this change, keys **6** and **7** will be the Telecenter Keys, leaving 13 direct select keys (8 - 20).

Transfer and Conference Calls:

With the remote hook-flash feature set at Location Code **64110**, the **TC4400** can transfer and conference calls within the Centrex system after answering by hitting the trunk key again to get Centrex dial tone and then dialing the Centrex extension.

Night Set-up:

If desired, an external EEPROM switch could be used so the TC4400 has only 3 trunks and local access at night and the remaining trunks go to various extensions, such as: Gym, Music, etc.

Interconnect Layout Drawing 2 of 6

Administrative Phones to Central Office

Summary: The Jefferson School, shown below in drawing KM0888, is a small system with 2 Central Office (CO) trunks, 8 **Administrative** lines, and 25 Staff Stations.

Incoming Call Handling

Normal: There are two system operators with single line administrative phones on lines 5 and 6. Since the trunks are both AAls, all incoming calls will come to line 5. If line 5 is busy, the call will go to line 6. If both lines 5 and 6 are busy the incoming call will be sent to line 7 the principal. This may be an undesirable overflow situation.

Busy: The possibility of having both lines busy is limited: As soon as the operator transfers a call her line becomes available again. If these two operators use their phones for other business involving internal and external communication to such an extent that they may both be busy during the times of the day, then the principal (PPL) will receive the call. This may prove unacceptable or, it may be a desirable method of motivating efficient call handling. If a lot of overflow comes to the principal:

Move the principals phone from line 7 to line 8, and change physical line 7 attribute from A: 1 to A:. Now, if both operator lines are busy, hunting will stop at line 7, the calls will be ignored by the system, and the caller will continue to hear ringing. Therefore, this option is still **unsatisfactory.**

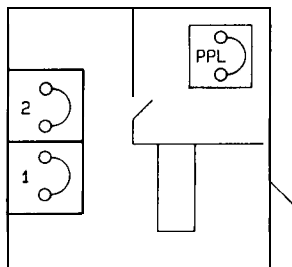
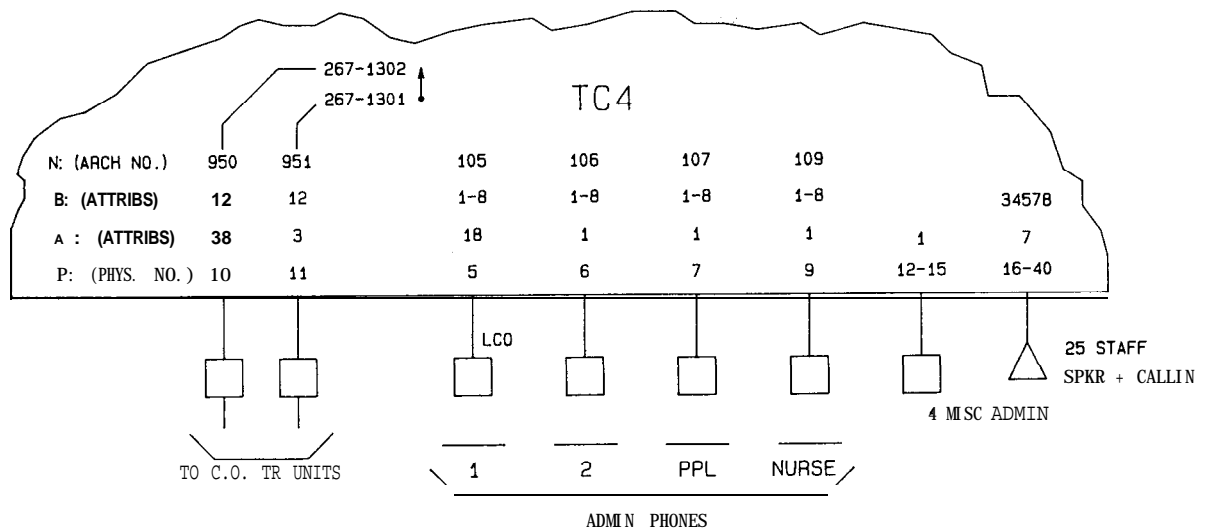

INTERCONNECT	LOCATION	CODES
64000	5	ATTENDANT LOCATION
64016	5	DIAL '0'
64034	10	DIAL '9'
64222	5	RINGBACK LOCATION ATTENDANT

TELECENTER IV
 JEFFERSON SCHOOL INTERCONNECT
 RAULAND-BORG CORP.
 MADE IN U.S.A.
 KM0888-A

Leave the PPL phone at line 8 and give the first secretary a two-line phone which includes line 7. When both secretaries are busy and a call comes in, it can be answered by the first secretary by putting her first caller on hold.

Note: Only two outside calls are possible at any time because there are only two trunks.

Transfers: If a call is transferred while the line is ringing and no answer is given, it will, after a set amount of time, come back to line 5, as set in Location Code 64222. This returned call will not be distinguishable from new incoming calls until answered. When answered, a series of beeps will tell the operator that this is a ring-back. Transferring without waiting for an answer is not generally appropriate with this small configuration.

Outgoing Call Handling:

Authorized administrative lines can get an outside line by dialing 9 provided a trunk is available. Location 64034 directs such calls to line 10 which is the first of the two C.O. trunks, and the hunt bit attribute A:8 will cause the TCIV to supply the next line in the event that line 10 is busy.

Access Restrictions: Since administrative phones have the B: 1 and not the B:2 attributes, they can access trunks for local, but not long distance calls. An administrative line may get access for long distance by dialing the operator and requesting transfer to a trunk.

Local access requires the TCIV receivers to stay connected to a line until sufficient digits are dialed to verify acceptability. If the dialed digits prove unacceptable, or if the receiver time limit is exceeded, an automatic disconnect will occur. Dialing 800 is allowed. Dialing 0 is not allowed. Dialing followed by an area code other than one of three allowable ones will result in a disconnect as will dialing an unacceptable prefix. When area codes are allowed, it can be without further restriction of prefixes, or with the same set of prefixes allowed as with no area code.

Internal Call Handling:

Internal operator calls (dial 0, set at Location Code 64016) come to line 5 as do incoming **interconnect** calls, but interconnect calls will have a double ring. The double ring would be masked by the ringing circuitry of a key phone, but will be audible with the single line phones **used in this case.**

Phone 5 has primary responsibility for answering call-ins because it has a display. Speaker calls may be transferred to trunk lines, but the operator must stay on the line to supervise the call.

Collision of incoming and outgoing calls

Collision occurs when incoming and outgoing calls attempt to **access** the same trunk simultaneously. The result, the two callers get connected to one another instead of their intended targets. To minimize the chance of collision, it is good practice to always have the phone company hunt CO. trunks in opposite order from the way the TCIV hunts them. On the drawing, this is shown with an arrow, located by the C.O. line directory extensions. The arrow points in the direction the C.O. hunts. The TCIV hunts upward from the lowest physical number (10).

Interconnect Layout Drawing 3 of 6

Key Phones to Central Office (Day Set-up), AAI Line8

Summary: **The Washington School has separate** programming for day and night time. The day set-up is shown below in drawing KMO889. This is a medium size system with 5 C.O. trunks, 5 keyphones, 25 administrative phones, and 75 staff stations (each equipped with a phone, speaker, and call-in switch). Keyphones are designated by Eve blocks arranged horizontally to symbolize the keys. Darkened triangles in the corners of some blocks indicate incoming lines which cause the keyphone to ring (set by hardware jumpers in the key system). Keyphone 1 is the primary operator instrument. The first 4 trunks are AAI and are in a hunt group. The last trunk is a DIL private line for the principal.

The keyphone arrangement is non-rectangular; that is, not all of the key phones have the same lines on every key (e.g.: keyphone 5 (PPL) has a special private line for the Principal and does not have access to TCIV line 11). This setup requires an extra K400E card and minor variation in wiring of the Key System (see the Key System manual, KI-1491). Therefore, this key system requires 6 line cards.

Incoming Call Handling:

Normal: Assuming no lines are busy, a typical incoming call will cause the first available key on Keyphone 1 to ring. The operator will answer it and transfer it to another point in the system, freeing the key for another incoming call.

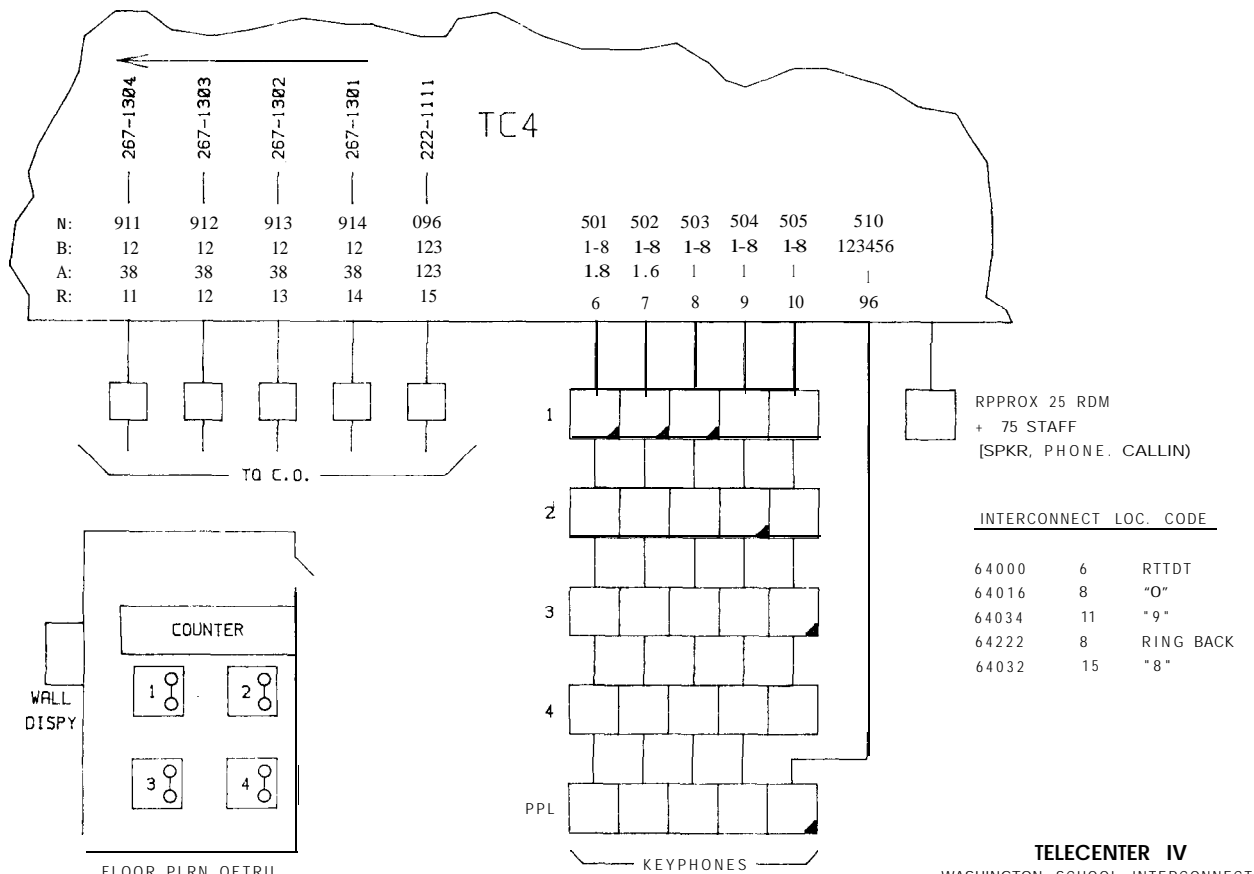

TELECENTER IV
 WASHINGTON SCHOOL INTERCONNECT
 RAULAND-BORG CORP.
 MADE IN U.S.A.
KMO889-0

- Busy:** Should all 3 primary key positions (6,7,8) be busy, calls will overflow to the next two lines, 9 & 10, ringing key phones 2 & 3, respectively. Phones 2, 3, and 4 are in the same office and can pick-up any call accessible to phone 1 (i.e.: ringing, holding, or talking on phone 1). If all five lines are busy, no further backup is available since line 11, the next physical number in sequence, is not administrative (it is programmed A:3 for AAL).
- Private:** Line 15 is the Principal's private DIL trunk. It is private because its B:3 attribute is on. It goes to the Principal because its N: field (architectural number) contains 096 which is the physical number of the Principal's line. If the Principal's phone is busy when an incoming call is received, the call will be automatically routed to the attendant phone, located at physical number 6 and programmed at location code 64000.
- Note:** If attendant answering is not acceptable, turn on the DIL line B:7 attribute. This will cause incoming calls on the principals private line to ring until answered or the caller hangs-up.
- Transfer:** Calls which are transferred without waiting will ring-back to the operator if not answered within a programmable time limit. Ring-backs go to Keyphone 1: Key 3 (programmed at Location Code 64222). This allows the operator to distinguish ring-back and internal calls from new incoming calls, except when the other lines are busy. When a ring-back call is answered a series of audible beeps is generated to further differentiate it.

Outgoing Call **Handling:**

Access restrictions are the same as in the Jefferson System, described above. Authorized administrative phones may dial for outgoing calls, and will only use the first 4 trunks. The DIL line, physical number 15, can be accessed by dialing 8, set at Location Code 64032. Since the DIL B:3 attribute is set, only the Principal can obtain this trunk. By dialing 8 for outside calls, the Principal can:

Make sure that outside callers will receive a busy signal if they attempt to call while the his/her outside line is in use.

Be assured of always having a line available for making outgoing calls.

Reduce traffic load on trunks 11-14 by using trunk 15.

Problems: Depending on the situations, the following may or may not be problems.

Outside callers to the Principal's private line will not receive a busy signal when the Principal's phone is being used for an inside call.

If the Principal's private line is accessed by another station, outside callers may receive a busy signal when the Principal is not busy.

The Principal's outside line may be under utilized if only the Principal has access **to** it while the other lines (trunks) may be over utilized.

Alternative 1:

Make the DIL public by setting B:3 off. Then, if the first 4 trunks are busy, any authorized administrative phone may use the DIL for outgoing calls. This increases total system trunk capacity by providing greater access to the DIL; meanwhile, retaining direct inward dialing for the Principal.

Alternative 2:

Move the DIL line to the beginning of the hunt group (physical number 11) and set its B attribute to 1238. This will Include all 5 trunks in the hunt group. The Principal would then dial 9 to obtain a trunk like anyone else and would always get the DIL. All others will pass by the DIL and continue hunting for an available trunk. Then, when the principal places an outside call, callers dialing the private line will get a busy signal from the TCIV. One exception: If the principal transfers a call on the private line to someone else, while the DIL trunk is in use, the Principals calls will go to the other trunks, and outside callers will get busy signals from the telco.

Alternative 3:

Same as alternative 2, but make the DIL public (B:3 off) and change the linear hunt format to circular (A:8 off on all interconnect lines and specify a circular-hunt group for trunks 11-15 at Location Code 64034). Each time an outgoing call is placed from the TCIV, a circular hunt begins at the physical number following the last physical number tested in the preceding circular hunt. That is, if the last circular hunt accessed an outside line at physical number **13**, **the** next circular hunt will begin at physical number 14. Each circular hunt goes upward through physical numbers, beginning at the designated physical number. When it reaches the highest physical number in the group, it goes to the lowest physical number in the group and continues upward until all trunks have been tested or an available trunk is found. An outside line busy signal will not be given until each trunk is tested once. With this configuration, outgoing traffic is distributed evenly to all trunks instead of being concentrated at the trunks with the lower physical number.

Internal Call Handling:

Internal operator calls (dial 0) go to line 8, ringing the third key of keyphone 1. As an alternative, these calls could be routed to line 9, ringing keyphone 2. This would divide up the operator duties between two people. Also, all keyphone users are fully authorized, each having all eight "B" attributes. This includes answering call-ins. Therefore, since they all share access to a wall display (see floor plan), the duty could be taken by any of them.

Interconnect Layout Drawing 4 of 6

Key Phones to Central Office (Night Set-up), MI Lines

Summary: The Washington School Night set-up, shown below in drawing KM0890, is the same as the previous set-up except the programming has been changed. It is set-up now for after-school hours and the operator has gone for the day. (This change in programming can be accomplished by the flip of a switch: see Drawing KM0896.)

Incoming Call Handling:

Only the trunk assigned to the main school number is still routed to the operator. All other trunks have been converted to DIL and are routed to various key points around the school (gym, music room, field house and principal).

Outgoing Call Handling:

All 5 trunks are in a hunt group and are available for outgoing calls. The DIL lines are not private (B:3 is off), therefore any authorized phone can dial out on them. The gym, music room and field house have restricted outside access (which they don't have during the day) to allow them to call for help in an emergency.

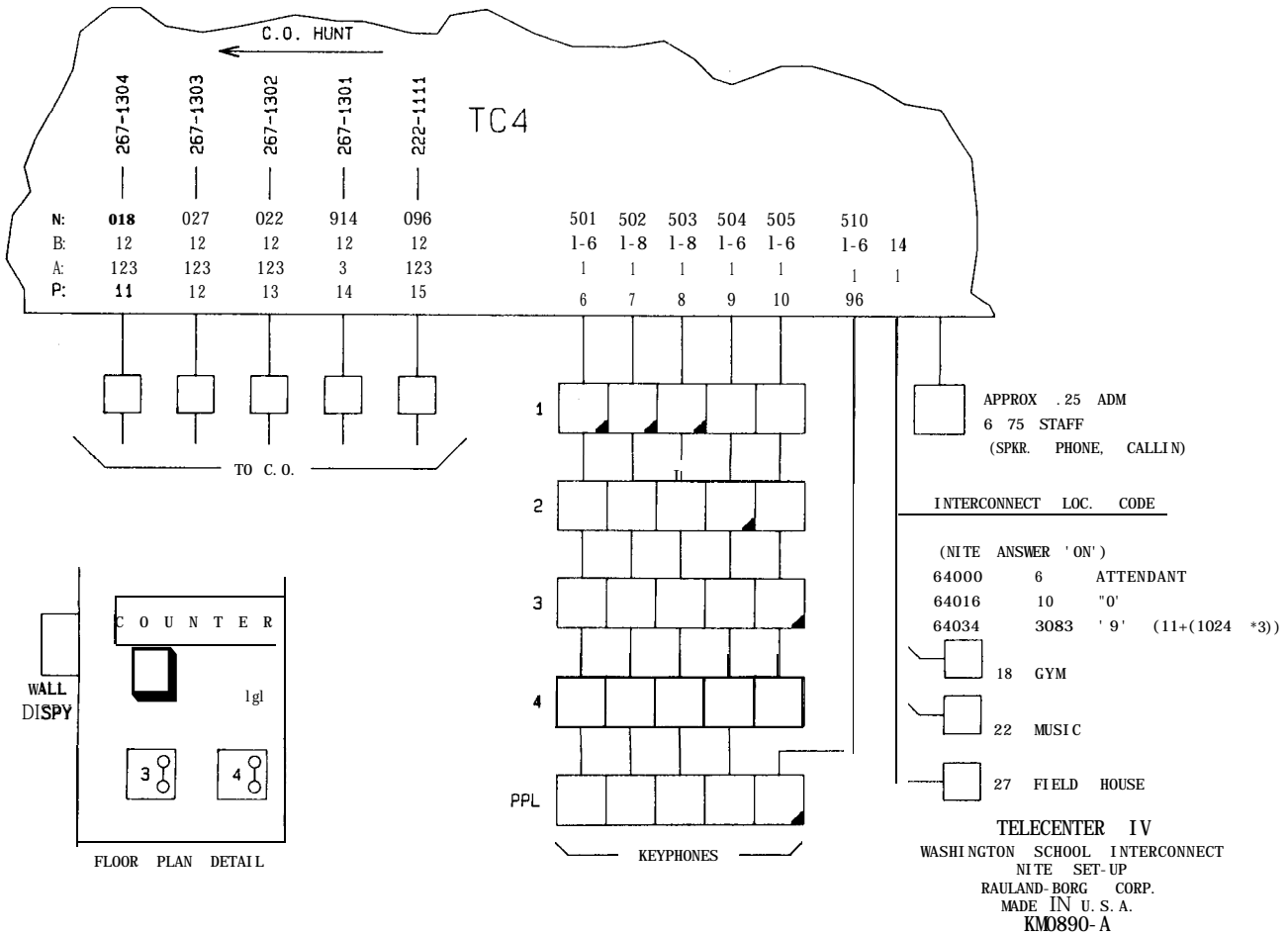

Interconnect Layout Drawing 5 of 6

Key Phones to Central Office, Private (DIL) Lines

Summary: The Lincoln School, shown below in drawing KM0891, is a medium size system composed of 4 trunks, 3 key-phones (arranged in a non-rectangular format), 10 administrative phones, and 75 staff stations consisting of multi-link staff phones with speakers. This system differs from the previously discussed Washington system in that all trunks are DIL lines. Once again, the triangle-shape marks in the keyphone square indicate lines which ring.

Note: The system is non-rectangular because each key phone has a different line (i.e.: K400E line card) serving the last key and, thereby, providing a private line to each. See the key system manual for an explanation of this type of wiring.

Incoming Call Handling:

Normal: Each incoming trunk is routed to a specific location in the system: One trunk is routed to the principal and the remaining three are routed to the first three keys of the secretary's display phone. The first line in the group (line 10) is routed to key 1 (line 16), the second line (11) to key 2, and so on. This ensures that calls from 1304 will go to key 1, 1303 will go to key 2, and so forth.

The one-to-one relationship between the operator keys and incoming trunks allows the operator to tell from the keys which DIL lines are ringing in. The first three keys should be reserved for answering outside calls. If a key is in use when its associated trunk receives an outside call, the TCIV will send the call to the Attendant Line (programmed at Location Code

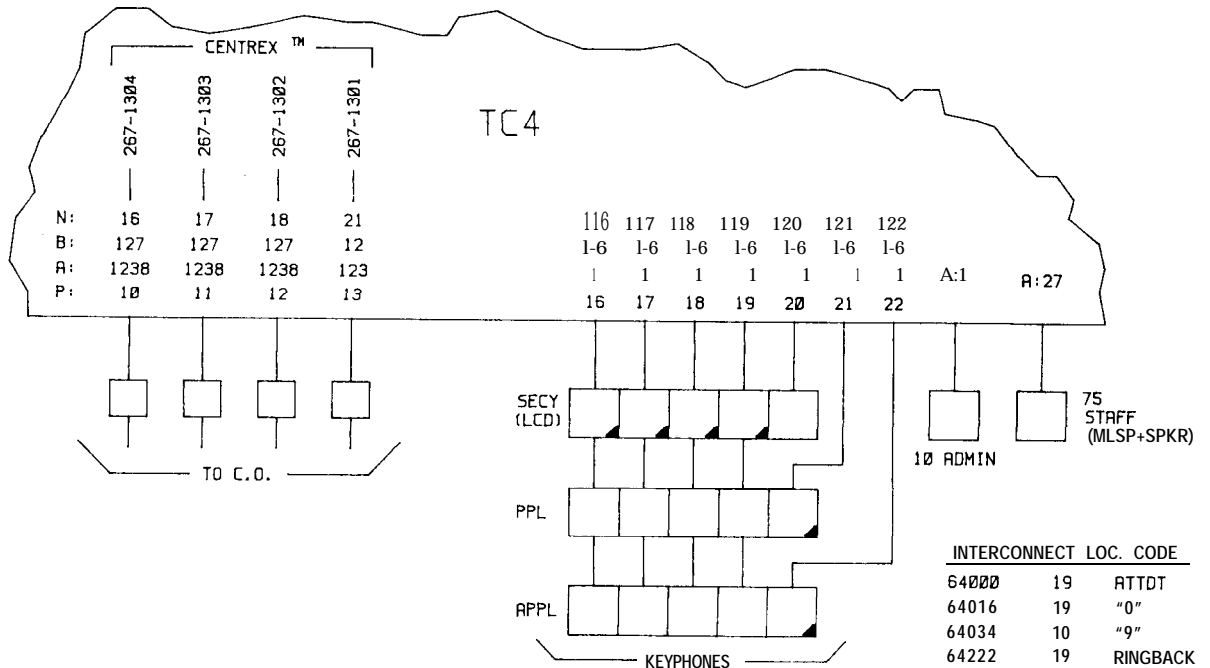

TELECENTER IV
 LINCOLN SCHOOL INTERCONNECT
 KEY-OIL
 RRULRNO-BORG CORP.
 MROE IN U.S.R.
 KM0891-0

64000). This could lead to some user confusion as the Attendant Line does not normally get calls from the outside. Also, when a call is transferred, the key lamp will go out even though the trunk is still in use.

Outgoing Call Handling:

All trunks, including the principal's, are accessible for outgoing calls (B:3 is off) and they will go out on the first available trunk, starting with line 10. Because the DIL lines are in a hunt group for outgoing calls, there is no direct correspondence between keys and trunks. If **9 is** dialed using key 2 on any key phone, trunk P10 will be accessed if available because that is where the outgoing search begins.

Alternative:

Make all DIL lines private (set B:3 on) to cause each outgoing key-phone call to use a specific trunk. The limitations associated with this alternative is that no one else in the system can make direct outside calls, forcing the operator to transfer each to a trunk.

Note: Outgoing calls hunt up from line 10 (TCIV hunt path) and incoming calls hunt down from line 12 (Centrex Hunt path). This minimizes collision between incoming and outgoing calls.

Note: The principal's trunk is at the end of the hunt group. This means that it will be the last one assigned to a outside call and, consequently, the most likely to be free for receiving incoming calls.

Internal Call Handling:

Internal calls and call-ins are processed by the operator on an LCD-display keyphone. Internal calls (dial 0) come to key 4 (line 19). This distinguishes them from incoming interconnect calls which typically come to keys 1 through 3 (lines 16 - 18).

Interconnect Layout Drawing 6 of 6

Administrative Phones to PBX

summary: The **Roosevelt** School, shown below in drawing **KM0893**, is a large system with 8 central office trunks, a PBX, and a TCIV. The twelve phones in the PBX are for office and administrative purposes and get heavy use. The TCIV supports 40 administrative and 40 class-room telephones and 190 speakers. The speakers are used for paging and class change only: they do not incorporate intercom features.

Note: Amplifiers and TC4171 COA modules are shown below to emphasize their importance where audio must pass through the TCIV and PBX to reach the outside. Generally, this level of detail would not be shown in an **interconnect** layout drawing.

Incoming Call Handling:

Normal: The PBX console operator handles all incoming traffic and routes it to PBX or TCIV phones. When the Console dials 8 to get into the TCIV, it receives a DISA line and dial tone, then the operator dials the TCIV extension. At this time the PBX operator has two choices, neither of which may be acceptable in some systems.

The operator may disconnect after the target station starts ringing. In this case, the target station will continue to be rung until answered or the total keep-alive time elapses (refer to keep-alive process). In the latter case, the TCIV will

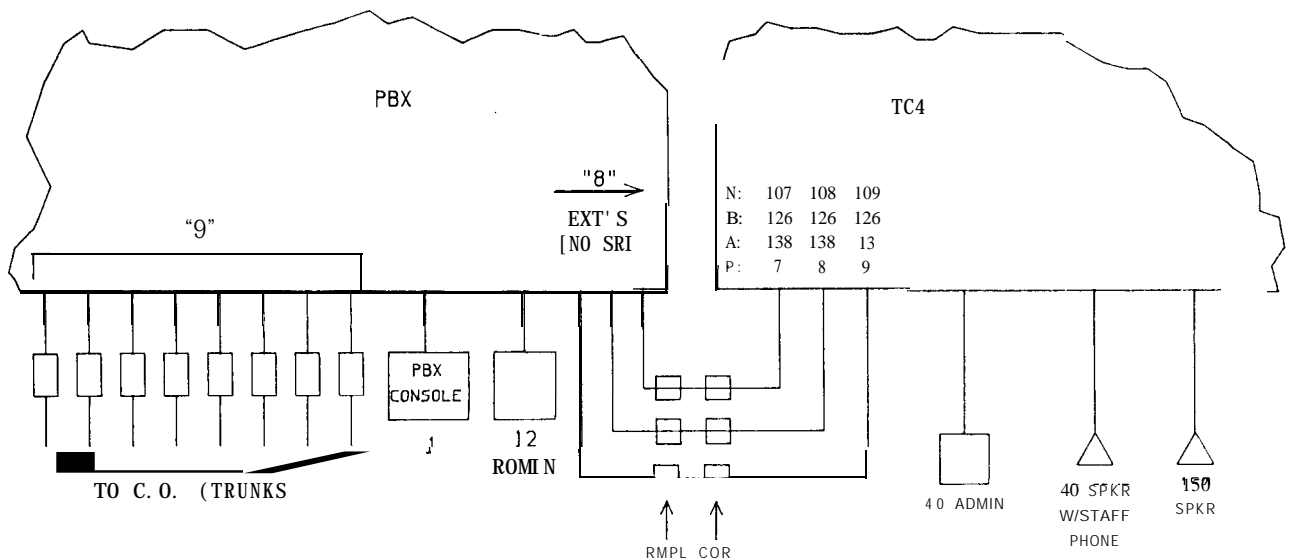

INCOMING - PBX CONSOLE MUST WAIT FOR TC4 EXTENSIONS TO ANSWER ON TRANSFER.

OUTGOING - TC4 EXTENSIONS MUST DIAL "9" TWICE FOR A C.O. LINE.

TC4 EXTENSIONS HAVE BETTER ACCESS TO TC4 FUNCTIONS THAN DO PBX EXTENSIONS. (SEE TEXT: KEEP ALIVE & TRANSFERING).

INTERCONNECT	LOC.	CODE
64000	11	ATTD
64034	7	"9"
64036	600	KEEP RLIVE
68038	600	KEEP RLIVE RESPONSE
64210	9	PBX ACCESS DIGIT

TELECENTER IV
 ROOSEVELT SCHOOL INTERCONNECT PLRN
 PBX-ROM IN
 RRULRND-BORG CORP.
 MADE IN U.S.A.
 KM0893-0

drop the DISA line **connection** to the PBX and the PBX will **disconnect** the outside call. Therefore, unless outside callers are familiar with the keep-alive process, their **calls will be disconnected.**

The operator may remain off-hook until the target extension answers.

In this case, the target extension takes over supervision of the PBX line when the operator hangs-up. The target station can then transfer the call within the TCIV or the PBX (see remote hook-flash below). If the target station doesn't answer or is busy, the operator can disconnect from the TCIV and return to the calling trunk using the console.

Outgoing Call Handling:

PBX extensions dial 9 to get C.O. dial tone and TCIV phones 9 to get PBX dial tone. For an authorized TCIV administrative station to dial a C.O. trunk, it must dial 9 (get PBX dial-tone) then dial 9 (get C.O. dial-tone). This assumes the TCIV is programmed (Location code 64210) for dial-9 outside access. Normal TCIV restrictions on area-codes and prefixes (see Programming Manual) will apply to all calls over C.O. trunks.

Alternative:

If outside call activity from the TCIV will be high, move a few C.O. trunks from the PBX to the TCIV for outgoing calls. This will reduce traffic between the PBX and TCIV and also simplify the outgoing call process.

Internal Call Handling:

Both TCIV and PBX extensions are fully functional within their own system; however, there are important differences between PBX and TCIV extensions when they begin calling from one system into the other.

From TCIV to PBX

TCIV phones must dial 9 to get PBX dial tone and then dial the target PBX extension. The line will ring until the target extension answers or the caller hangs-up. If the extension is busy, a busy signal will be given by the PBX. Once the PBX is obtained, the TCIV extension will be treated like a PBX extension.

TCIV calling is restricted by line attribute programming within the TCIV. The line attributes determine paging, call-in answering, and tone capabilities. Any TCIV extension can call any PBX extension. Area Code and Prefix restrictions are TCIV programmable.

TCIV callers can transfer calls within the PBX using the remote hook-flash process (see below). This would not be common for internal only calls.

From PBX to TCIV

PBX extensions dial 8 to get TCIV dial tone and then dial the TCIV extension or function desired. If a talk-path is established, normal communication ensues; however, the keep-alive process is required unless an off-hook TCIV extension is reached within the keep-alive time (typically 20 seconds).

All PBX extensions using the TCIV have those features available which are available to the TCIV line being used. These restrictions are programmed via the DISA line attributes, such as: paging, tones, and intercom.

PBX extensions can transfer TCIV speakers, staff, and administrative phones to other PBX phones, but not back into the TCIV because PBX extensions cannot send a hook-flash or transfer request to the TCIV.

PBX extensions at staff locations cannot be tied into the TCIVs annunciator system or operated in coordination with speaker intercoms. That is, after receiving a speaker call, private communication cannot be obtained by picking up the PBX extension.

Alternatives:

Extension Assignments: This is a small system design which assumes minimal traffic between the TCIV and the PBX. To optimize extension assignments, put into the PBX those which will primarily receive outside calls and put into the TCIV those which will mainly require the intercom and other TCIV features, including outside access via the PBX. Thus, the PBX will handle most outside calls and no traffic problems are likely in the TCIV system.

E&M Interface: To eliminate use of the keepalive process, install an E&M interlace between the PBX and TCIV (see the E&M Interface Specification). **This will** improve the quality of service the TCIV provides PBX extensions which will then be able to perform all-page and call room speakers. (No COA module is required if an E&M interlace is used: refer to the Call Answering Devices section in this manual for more information on special circuitry and wiring requirements).

DIL Interface: Change two of the three DISA interface trunks to DIL trunks to simplify call transfer procedures from the PBX to the TCIV. The TCIV does not make the COA appear off-hook on a DIL line until the target extension goes off-hook, thus eliminating the need to use the keepalive process and allowing the PBX operator to transfer calls across the DIL interface and disconnect without waiting for an answer. This will be helpful if there are two TCIV extensions that receive most of the PBX to TCIV traffic.

C.O. Trunks to TCIV: To reduce traffic through the PBX to TCIV interlace and simplify some TCIV operations, provide trunks (@IL, DISA, or AAI) diy to the TCIV and bypass the PBX.

In-Service Training Procedure

Summary: One of the **most important things required for a successful interconnect project is to teach the user how to use the system, correctly. This is** called In-Service Training and must be done on the day that the system is first put into service in order to get people started with a positive feeling and prevent the possibility of a bad first impression for some minor reason. If something should go wrong, the user will know who to call to get it fixed quickly. Extra visits may be necessary to catch all of the people but providing this type of service is what makes a **communications** provider stand-out to his customers.

A follow-up visit after two or three months service is also highly advisable so that any small complaints can be found and fixed without waiting for them to go through channels. This is a way to avoid surprises where small problems can get blown out of proportion.

Make the In-Service Training and follow-up a part of the plan right from the beginning. Since an **interconnected** TCIV may be an organizations only communication link to the outside world, it must work the first time and every time. The In-Service Training and follow-up visits are key elements in accomplishing this goal.

Rules for a successful In-Service Training performance:

1. The person performing the In-Service Training should:
 - Be knowledgeable of and practiced in all TCIV features and functions.
 - Be familiar with the system interconnect plan.
 - Be verbally skilled and people oriented in order to convey the necessary information with patience and efficiency. Mechanical or technical skills are of secondary importance in this situation.
2. Arrive on site and practice the In-Service Training procedures prior to formal presentation.
3. Prepare and provide written notes based on information from the operation section of this manual (KI-1585) and arranged according to importance for the customer using familiar language, department names, numbers, etc.
4. Demonstrate, explain, and then coach the people working the system. Be alert to observe operational errors and problems with understanding and, when appropriate, suggest better ways of accomplishing a function.
5. Ensure the development of operational skills and knowledge of important details are reinforced through practice and repetition.

Special Training Considerations for PBX-TCIV Interconnect Systems:

If the following processes must be used by PBX extensions, they must be clearly understood to avoid service calls on properly operating equipment and poor customer relations. See the appropriate section of this manual for a full description of these processes.

Remote hook-flash allows PBX trunk to PBX extension transfers through the TCIV.

Keep-alive process controls the disconnect of the TCIV when the PBX does not supply a service request.

Telco Installation Planning Guide

Summary: Interconnect lines from any central office source must be connected to the TCIV through TC4171 Central Office Adapter Modules (COA). COAs are FCC approved devices and, therefore, must be installed in compliance with Part 68 of the FCC Rules and Regulations. Read the **FCC Requirements in this manual** and perform the procedures below to ensure compliance.

Step 1 . Telco must install an RJ2 1X demarcation jack which connects to a 25 pair ribbon cable capable of handling 25 lines wherever this type of connection is required (e.g.: interconnect block).

Telco must install an RJ1 1C or RJ1 1W demarcation jack at each location which will use a standard modular connector.

step 2. Locate the compliance label on each COA and provide the following information to the telco.

- a. Notification that an FCC approved device will be installed on the telco line.
- b. Number of lines receiving such devices.
- c. Registration Number of each device (EY65P7-15781-WP-T).
- d. Ringer equivalence of each device (1.7B).
- e. Numbers and placement locations for each demarcation jack required.

Step 3. Obtain an installation date for the demarcation jacks from the telco. This is the earliest date the system can be cut-over.

step 4. Determine whether the trunks are loopstart or ground-start and make a note for the installation team. (Loop-start is simplest and easiest to test.)

Emergency Power Failure Changeover

Summary: Emergency power should allow continuous communication between the organization and the outside world during a power failure. From the following options, select the one which will best meet the customer's emergency action plan and local requirements for protecting life and property.

Option 1. Standard Central Office Line

Any direct line which goes directly to the Central Office will continue to operate when local power is lost.

This option will not allow use of the TCIV paging or intercom functions.

Option 2. Manual Changeover **Switch**

A switch on a standard telephone or its receptacle which can be used to connect to a Central Office trunk line. The Central Office line will operate without local power.

This option will not allow use of the TCIV paging or intercom functions.

Option 3. Trunk **Transfer Unit**

A unit which bypasses the TCIV and automatically **connects specified trunks** directly to administrative stations will ensure minimal outside communication service during a power outage.

Available units which will handle 5 or 10 trunks require separate 24 or 48 Vdc power supplies. One model is available from Porta System in New York State through Graybar or Anixter.

This option will not allow use of the TCIV paging or intercom functions.

Option 4. Uninterruptable Power Supply

If the installation requires an uninterruptable power supply, suitable products are available from electric supply houses such as Graybar or Anixter.

This option will allow normal use of the TCIV and its paging functions.

NOTE: Phones connected to ground-start trunks must be modified to provide a ground-start tap for use during power failure.

If implemented, additional power may be required for a TC4400 or an EKSU.

Keep-Alive Process

Summary: This process applies to DISA lines only. The keepalive process is required when a caller from a remote system wishes to maintain communication and a service request is not provided by the remote system to let the TCIV main program know when the remote system **disconnects**. When it is not provided, the keepalive process ensures a TCIV line is not held after the remote line **disconnects**.

Note: All individuals required to use this process must be fully trained to do so. They needn't understand the technicalities, but rather that when placing certain types of calls - a beep in the headset must be responded to by pressing a telephone key or they will be disconnected.

The keepalive process begins when the TCIV fails to receive an expected service request. The process proceeds through three stages:

Stage 1. Keep-Alive Delay Time (Location Code 64036) provides a timeout which begins after completion of dialing an extension or function of the TCIV. At this time, the DISA trunk will be **connected** to an intercom speaker, a paging function, or the dialed extension will begin ringing. When the timeout occurs, a warning beep is provided to the caller and the process proceeds to Stage 2.

Stage 2. Keep-Alive Response Time (Location Code 64038) provides a time period during which the caller may respond to the warning beep by pressing any telephone key (except 0) to send a DTMF tone. This action will maintain the function by resetting the Keep-Alive Delay Time, returning the process to Stage 1. If the DTMF tone is not sent in time, the process continues to Stage 3.

If 0 is pressed (version 102 and later software) upon receiving the warning beep, the TCIV will terminate the call. Therefore, the caller should press **0** when no further contact with the TCIV is required. This will release the line and the TCIV receiver and end the process (it will not go to Stage 3).

Stage 3. After both timeouts have occurred, the TCIV releases the target extension or function selected by the caller, delivers a dial-tone, and starts the dial-tone timeout period (Location Code 64012). The caller must select another extension or function within the dial tone timeout period or be disconnected.

Automatic termination is necessary when a PBX does not supply a service request (disconnect signal) to the TCIV because the TCIV cannot detect when the PBX caller has hung up.

Note: There are two alternatives to using the keep alive process if a PBX does not supply a service request.

Use an E&M or Modified COA interface between the PBX and TCIV.

Have the operator supervise PBX to TCIV calls.

Remote hook-flash:

Summary: If the TCIV is **interconnected** to a PBX, TCIV extensions must use the remote hook-flash process to transfer an incoming trunk call to a PBX extension. When an incoming trunk-call is in progress, a TCIV extension can use the following process to get PBX dial tone and then send the DTMF tones required to facilitate the transfer to the remote PBX extension or to create a conference call if the remote system will support it.

Note: All individuals required to use this process must be fully trained to do so.

step 1. With a call in progress, depress the hook-switch (tap button if installed).

The caller will be placed on standby.

The TCIV will connect a receiver to your line and provide dial-tone.

Step 2. Depress the asterisk (* = remote hook-flash).

The TCIV receiver will transmit the remote hook-flash signal to the PBX by taking the associated COA module off line for the time specified in Location Code 64110.

The PBX will respond with its dial-tone.

Step 3. Dial the number of the target PBX extension.

Step 4. Wait for the target extension to answer.

Step 5. Hang-up to complete the transfer.

OR

Hook-flash and dial * to create a conference call (if the remote system will support this).

Interconnect Ordering Checklist

Summary: Some of the items listed below are necessary for an interconnect system and others are optional. Note the quantity required for each in the blank provided.

ITEM	QUANTITY	SYSTEM DESIGN NEEDS
TC4171 (COA)	_____	Except where E&M interfaces are used, order one COA for each trunk line between the TCIV and another system (Central Office, Centrex, PBX, EXSU).
TC4170	_____	Order one for each set or partial set of 11 (eleven) TC4171 COA Chassis modules (1-11 TC4171 = 1 TC4170; 12 - 22 TC4171 = 2 TC4170; etc.).
Repeater Amp	_____	Order one repeater amp for each TCIV trunk line to make-up for 6 dB audio signal losses in the TCIV (see wiring diagram KM0716).
Repeater Amp Chassis	_____	Order one for each set or partial set of 8 (eight) RTec (VFR 1050 List 2) Repeater Amps (1-8 RTec = 1 Chassis; 9-16 RTec = 2 Chassis; etc.).
Repeater Amp Power Supply	_____	Order one 28 V d.c. Repeater Amp Power Supply for each RTec chassis.
Lightning Protectors	_____	Refer to Drawing KM0714 in KI-1587 for recommended model numbers. Order sufficient lightning protectors to ensure that grounding can be installed on each line (phone or speaker) which goes outside.
Line Converters	_____	If the remote system does not provide tone-dialing service, order one line converter for each interconnect trunk line. Obtain the appropriate part number/specification from the operator/vendor of the remote system.
TC4400	_____	If required, refer to RI-1559
KSU/EKSU	_____	If required, contact appropriate vendor.

Return to XI-1581 to determine additional TCIV system requirements (i.e.: Staff Stations, Administrative Stations, Paging Equipment, etc.)

Traffic Handling Requirements

Summary: It is a serious error to install an **interconnect** system that can't handle the customer's traffic. This procedure will guide you through the traffic planning process and ensure all factors are considered. It provides a Traffic Capacity Worksheet, clarifies typical traffic handling problems, and suggest several remedies for each.

A sample worksheet shows traffic calculations for the Jefferson system discussed earlier, focusing on traffic during the peak busy hour of the week, and assuming that internal traffic is less than external.

step 1. Identify all Traffic Sources in the system and note the quantity of each on the Traffic Capacity Worksheet.

Note: Traffic occurs when a person or device requests and receives a service. Only originators generate traffic; therefore, incoming traffic is assigned to trunks and outgoing traffic is assigned to the extensions doing the dialing. Traffic generated when a staff station is called in response to a call-in is assigned to the staff station because it generated the request for service, thereby originating the call. Thus, the analysis represents the net increase in traffic which occurs when staff stations are added to the system because they (staff stations) create traffic through call-ins.

Step 2. Calculate the Total CCS (100s of call seconds) required for each source by multiplying its quantity by the CCS/Hour factor, then sum the individual results to derive the Traffic Demand. (Factors supplied are averages and may not apply in individual situations.)

Step 3. Link Availability in the TCIV is set at 576 CCS/Hour (16 links times 36CCS/Hour). This is the total amount of time per hour that TCIV links are available for meeting Traffic Demand. Determine the TCIV traffic Intensity by dividing traffic demand by 576. If this percentage approaches or exceeds 90%, pay special attention to the following paragraphs. If not, continue to Step 4.

Link Un-Availability: Each link is capable of supporting two or more lines and/or trunks in a common audio connection. If too many requests are received too quickly, some are postponed or denied. As such the traffic is either handled or not handled. When links are not available, there is no path for dial tone, therefore Administrative phones cannot be used to place calls and Incoming calls on trunks are ignored. The CPU always senses service requests; however, links cannot be added so it waits for one to become available. Meanwhile, the user waits a few seconds, gives up, and, tries again later.

Link Remedies:

Equip heavy outside callers with two line phones having one direct and one TCIV line. The direct line does not tie up a TCIV link when in use; however, it cannot be transferred into the TCIV.

Assign fewer trunks to outgoing than incoming calling. This may require schedule adjustments by users who are unable to dial out during the busy hour.

Authorize fewer phones for dial access.

Design the system with two TCIVs, or a TCIV and a PBX.

Ensure all users are trained to properly disconnect after committing to a dialing sequence (i.e.: don't leave the phone off-hook): failure to do so may leave a link tied-up.

TCIV Traffic Capacity Worksheet (Example)

Source	Qty.	*	CCS/Hour	=	Total CCS
C.O. Trunks					
AAI and DISA					
50% incoming	<u>8</u>	*	18.0	=	<u>144</u>
Outgoing Only	<u>0</u>	*	0.0	=	<u>0</u>
Incoming Only	<u>0</u>	*	36.0	=	<u>0</u>
DIL					
Private	<u>0</u>	*	6.0	=	<u>0</u>
Shared	<u>0</u>	*	18.0	=	<u>0</u>
Incoming Trunk Traffic					<u>144</u>
TCIV Lines					
Administrative					
No Outside Access	<u>20</u>	*	1.5	=	<u>30</u>
Local Access	<u>15</u>	*	4.0	=	<u>60</u>
Full Access	<u>5</u>	*	6.0	=	<u>30</u>
Control Console					
10% out	<u>1</u>	*	3.60	=	<u>4</u>
Staff Phones	<u>100</u>	*	0.10	=	<u>10</u>
Outgoing Trunk Traffic					<u>134</u>
Traffic Demand					<u>278</u>
TCIV Traffic Intensity = (Traffic Demand / 576CCS) = .48%					
(Note: 576 = 16 links * 36CCS)					
<hr/>					
Trunk Traffic Loading (Demand)					<u>278</u>
Trunk Traffic Capacity					<u>288</u>
(36CCS * total number of all but Private DIL trunks)					
Trunk Traffic Intensity					<u>97%</u>
(Loading / Capacity)					

Receiver Unavailability: During busy periods with high traffic intensity both DTMF receivers (registers) may become busy and limit the system's call-handling ability. The DTMF receivers are required for only a few seconds when calls and transfers are made and if no DTMF tones are made they disconnect after 10 seconds. If both receivers are busy when call or transfer attempts are made, callers will have to repeat the hook-flash or wait for dial-tone. This is unacceptable if it occurs on a frequent basis.

Receiver Remedies:

Reduce the receiver time limit (the time allowed for input of a DTMF tone before disconnect) from ten to five seconds (see the Programming Manual KI-1584).

Install a TC4400 Call Control Console: It does not require a receiver for answering and transferring outside calls or for any dialing within the TCIV.

Limit the number of administrative lines with local access (B:2 off): This feature requires extra receiver time in order to receive prefixes and area codes dialed out.

Disallow repeat single button dialing (set Location Code 64106 to 0): When used on a series of calls, this feature ties up a receiver continuously.

Program frequently called internal numbers for single digit dialing (Location Codes 64016-34). This will minimize receiver access time when calling these numbers.

- Step 4. Outgoing Trunk Traffic is determined by the total CCS/Hour requirements of all originating sources which may access outside lines. Complete this section of the worksheet by carrying down the figures calculated for the itemized sources in Step 2.
- Step 5. Incoming Trunk Traffic is determined by the total CCS/Hour requirements placed on trunks by callers from the public exchange. Refer to the data obtained while conducting the Site Survey and enter the appropriate figure. One way of arriving at this figure is to estimate incoming trunk utilization as a percentage of available CCS.
- Step 6. Determine Total Trunk Traffic by summing the Incoming and Outgoing Trunk Traffic figures obtained in Steps 4 and 5. This figure represents the total trunk requirement represented by the current system design.
- Step 7. Subtract the number of private DIL trunks from the total number of trunks in the system and multiply the remainder by 36CCS to obtain Trunk Traffic Capacity. This is the total amount of time per hour that trunks are available for handling call traffic in the interconnect environment.
- Step 8. Determine Trunk Traffic Intensity by dividing Total Traffic Requirement by Trunk Traffic Capacity. If this ratio approaches or exceeds 90%, pay special attention to the following Paragraphs.

Trunks: The TCIV can normally handle up to 10 trunks coming from a Central Office, PBX, or another TCIV; however, while this is not a physical limit, if more than ten trunks seem to be needed, the traffic situation should be carefully analyzed. If all trunks are busy, a person attempting to dial in or out will get a busy signal. Along with the usual remedy of buying more trunks, some of the above Link Remedies can also be applied here.

TCIV traffic can be reduced by including a few 2-line phones with one line connected directly to the outside. This may also satisfy the power fail alternative requirements for some applications.

TCIV Traffic Capacity Worksheet

Source	Qty.	*	CCS/Hour	=	Total CCS
C.O. Trunks					
AAI and DISA					
50% incoming	_____	*	18.0	=	_____
Outgoing Only	_____	*	0.0	=	_____
Incoming Only	_____	*	36.0	=	_____
DIL					
Private	_____	*	6.0	=	_____
Shared	_____	*	18.0	=	_____
 Incoming Trunk Traffic _____					
 TCIV Lines					
Administrative					
No Outside Access	_____	*	1.5	=	_____
Local Access	_____	*	4.0	=	_____
Full Access	_____	*	6.0	=	_____
Control Console					
10% out	_____	*	3.60	=	_____
Staff Phones	_____	*	0.10	=	_____
 Outgoing Trunk Traffic _____					
Traffic Demand _____					
 TCIV Traffic Intensity = (Traffic Demand / 576CCS) = _____					
(Note: 576 = 16 links * 36CCS)					
 Trunk Traffic Loading (Demand) _____					
 Trunk Traffic Capacity _____					
(36CCS * total number of all but Private DIL trunks)					
 Trunk Traffic Intensity _____					
(Loading / Capacity)					