

Scanned

HEATHKIT[®] MANUAL

for the

**12-VOLT AUTOMOTIVE
DELUXE TIMING LIGHT**

Model CI-1040

595-1466-07

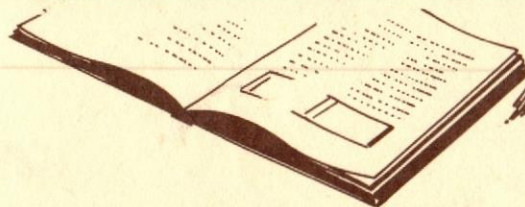

HEATH COMPANY • BENTON HARBOR, MICHIGAN

HEATH COMPANY PHONE DIRECTORY

The following telephone numbers are direct lines to the departments listed:

Kit orders and delivery information	(616) 982-3411
Credit	(616) 982-3561
Replacement Parts	(616) 982-3571
<i>Technical Assistance:</i>	
R/C, Audio, and Electronic Organs	(616) 982-3310
Amateur Radio	(616) 982-3296
Test Equipment, Strobe Lights, Calculators, Clocks, Weather Instruments	(616) 982-3315
Television	(616) 982-3307
Automotive, Marine, Appliances, Security, General Products	(616) 982-3496

YOUR HEATHKIT 90-DAY FULL WARRANTY

If you are not satisfied with our service - warranty or otherwise - or with our products, write directly to our Director of Customer Services, Heath Company, Benton Harbor, Michigan 49022. He will make certain your problems receive immediate, personal attention.

Our attorney, who happens to be quite a kitbuilder himself, insists that we describe our warranty using all the necessary legal phrases in order to comply with the new warranty regulations. Fine. Here they are:

For a period of ninety (90) days after purchase, Heath Company will replace or repair free of charge any parts that are defective either in materials or workmanship. You can obtain parts directly from Heath Company by writing us at the address below or by telephoning us at (616) 982-3571. And we'll pay shipping charges to get those parts to you — anywhere in the world.

We warrant that during the first ninety (90) days after purchase, our products, when correctly assembled, calibrated, adjusted and used in accordance with our printed instructions, will meet published specifications.

If a defective part or error in design has caused your Heathkit product to malfunction during the warranty period through no fault of yours, we will service it free upon proof of purchase and delivery at your expense to the Heath factory, any Heathkit Electronic Center (units of Schlumberger Products Corporation), or any of our authorized overseas distributors.

You will receive free consultation on any problem you might encounter in the assembly or use of your Heathkit product. Just drop us a line or give us a call. Sorry, we cannot accept collect calls.

Our warranty does not cover and we are not responsible for damage caused by the use of corrosive solder, defective tools, incorrect assembly, misuse, fire, or by unauthorized modifications to or uses of our products for purposes other than as advertised. Our warranty does not include reimbursement for customer assembly or set-up time.

This warranty covers only Heathkit products and is not extended to allied equipment or components used in conjunction with our products. **We are not responsible for incidental or consequential damages.** Some states do not allow the exclusion or limitation of incidental or consequential damages, so the above limitation or exclusion may not apply to you. This warranty gives you specific legal rights, and you may also have other rights which vary from state to state.

HEATH COMPANY
BENTON HARBOR, MI. 49022

Prices and specifications subject to change without notice.

Assembly and
Operation of the

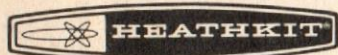

12-VOLT
AUTOMOTIVE DELUXE
TIMING LIGHT
MODEL CI-1040



HEATH COMPANY
BENTON HARBOR, MICHIGAN 49022

Copyright © 1972
Heath Company
All rights reserved

TABLE OF CONTENTS

Introduction	3	Specifications	28
Parts List	4	Theory of Engine Operation	29
Step-by-Step Assembly		Circuit Description	32
Circuit Board Assembly	6	Circuit Board X-Ray View	35
Wiring	11	Schematic . . . (fold-out from page)	35
Component Housing Assembly	17	Identification Photograph	36
Adjustments	18	Warranty	Inside front cover
Final Assembly	22	Customer Service	Inside rear cover
Operation	24		
In Case of Difficulty			
Troubleshooting Chart	26		

INTRODUCTION

The Heathkit Model CI-1040 12-Volt Automotive Timing Light is a self-contained, solid-state flash unit that is powered by the vehicle battery and features an all new triggering method. An easy-to-hold, high-impact plastic housing is ideally proportioned to allow you to aim the Timing Light in narrow spaces while keeping your hand at a safe distance from moving engine parts. A special, easy-to-connect, low voltage trigger pickup coil even permits you to connect the Timing Light while the engine is running. This also eliminates direct connections to the spark plug.

The flash from this unit is many times brighter than the flash from timing lights that operate from only the spark plug voltage. This extra brilliance is created by a high voltage within the Timing Light. A solid-state inverter circuit, mounted on a circuit board, steps up the battery voltage to provide this high voltage. The professional, or the do-it-yourself auto mechanic, desiring professional tune-up equipment will find the high intensity flash a pleasure to use even under full daylight conditions.

Many other timing lights receive their triggering signal directly from the spark plug voltage. However, in this Timing Light, a portion of the spark plug current is inductively coupled into the pickup coil to provide the low voltage triggering signal. Also, because an indirect triggering method is used, the Timing Light does not interfere with other test instruments that may be connected to the engine.

A special, built-in neon lamp allows you to accurately adjust the high voltage circuit without using special instruments.

Information on how to use and maintain the Timing Light is supplied in this Manual. Essential facts about automotive ignition systems and an example procedure for engine ignition timing are explained in the "Operation" and "Theory of Engine Operation" sections on Pages 24 and 29.

Refer to the "Kit Builders Guide" for complete information on unpacking, parts identification, tools, wiring, soldering, and step-by-step assembly procedures.

PARTS LIST

Check each part against the following list. The key numbers correspond to the numbers in the Parts Pictorial (fold-out from Pages 4 and 5).

To order a replacement part, always include the PART NUMBER. Use the Part Order Form furnished with the kit. If one is not available, see "Replacement Parts" inside the rear cover of this Manual. Your Warranty is located inside the front cover. For pricing information, refer to the separate "Heath Parts Price List."

KEY PART No.	PARTS No.	PARTS Per Kit	DESCRIPTION
RESISTORS			
1/2-Watt			
A1	1-49	1	22 Ω (red-red-black)
A2	2-143	1	133 k Ω precision
A2	2-14	1	1 M Ω precision

2-Watt			
A3	1-40-2	1	68 Ω (blue-gray-black)
A3	1-10-2	1	47 k Ω (yellow-violet-orange)
A3	1-24-2	1	100 k Ω (brown-black-yellow)

CAPACITORS

B1	21-16	1	.01 μ F disc
B1	21-733	1	.05 μ F disc
B2	27-61	1	.47 μ F Mylar*
B3	23-112	1	2 μ F paper
B4	25-254	1	4 μ F electrolytic

*Dupont Registered Trademark

KEY PART No.	PARTS No.	PARTS Per Kit	DESCRIPTION
ELECTRICAL PARTS			
C1	40-1905	1	Pickup coil
C2	40-1887	1	Trigger transformer
C3	54-287	1	Power transformer
C4	57-27	2	1N2071 silicon diode
C5	57-51	1	Silicon controlled rectifier (SCR) TIC-47
C6	417-278	1	PNP germanium power transistor (selected)
C7	11-90	1	200 Ω control
C8	64-84	1	Pushbutton switch
C9	412-34	1	Neon lamp
C10	412-73	1	Strobe tube

HARDWARE

#3 Hardware

D1	250-49	1	3-48 x 1/4" screw
D2	252-1	1	3-48 nut
D3	254-7	1	#3 lockwasher

#4 Hardware

D4	250-186	4	4-24 x 3/8" self-tapping screw
----	---------	---	--------------------------------

PARTS PICTORIAL

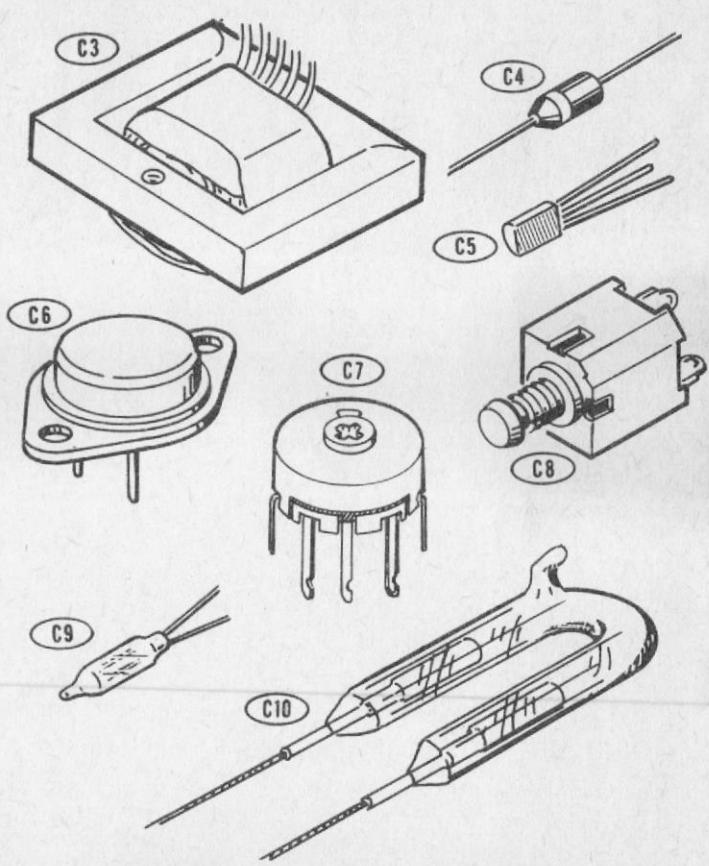
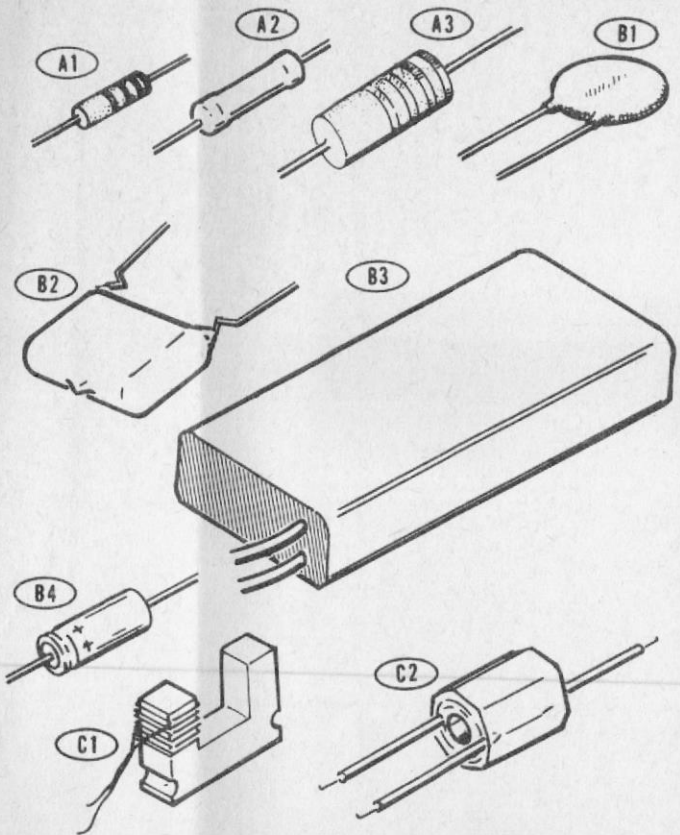

46

FOR PARTS REQUESTS ONLY

- Be sure to follow instructions carefully.
- Use a separate letter for all correspondence.
- Please allow 10 - 14 days for mail delivery time.

SEND TO:

HEATH COMPANY
 BENTON HARBOR
 MICHIGAN 49022
ATTN: PARTS REPLACEMENT
 Phone (Replacement parts only):
 616 982-3571

DO NOT WRITE IN THIS SPACE

INSTRUCTIONS

- Please print all information requested.
- Be sure you list the correct **HEATH** part number exactly as it appears in the parts list.
- If you wish to prepay your order, mail this card and your payment in an envelope. Be sure to include 10% (25¢ minimum, \$3.50 maximum) for insurance, shipping and handling. Michigan residents add 4% tax.

Total enclosed \$ _____

- If you prefer COD shipment, check the COD box and mail this form. COD

NAME _____

ADDRESS _____

CITY _____

STATE _____ ZIP _____

The information requested in the next two lines is not required when purchasing nonwarranty replacement parts, but it can help us provide you with better products in the future.

Model # _____ Invoice # _____

Date Purchased _____ Location Purchased _____

LIST HEATH PART NUMBER	QTY.	PRICE EACH	TOTAL PRICE
TOTAL FOR PARTS			
HANDLING AND SHIPPING			
MICHIGAN RESIDENTS ADD 4% TAX			
TOTAL AMOUNT OF ORDER			

KEY PART	PARTS	DESCRIPTION
No. No.	Per Kit	

#6 Hardware

D5	250-591	4	#6 x 1/2" screw
D6	250-559	7	6-20 x 5/8" self-tapping screw
D7	250-89	2	6-32 x 3/8" screw
D8	252-3	2	6-32 nut
D9	254-1	2	#6 lockwasher

Control Hardware

D10	254-5	1	Control lockwasher
D11	253-10	1	Control flat washer
D12	252-7	1	Control nut

WIRE

89-4	1	Power cord
344-52	1	Red hookup wire
343-2	1	Shielded cable

MISCELLANEOUS

E1	73-148	2	Precut foam tape
E2	73-64	2	2" foam tape
E3	73-147	1	3" foam tape
E4	73-3	1	Grommet
	75-715	1	1-1/2" x 2" cardboard insulator

KEY PART	PARTS	DESCRIPTION
No. No.	Per Kit	

Miscellaneous (cont'd.)

	214-183	1	Housing
			<i>Consisting of:</i>
E5		1	<i>Housing half (component)</i>
E6		1	<i>Housing half (cover)</i>
E7	260-58	1	Battery cable clip (black insulation)
E7	260-59	1	Battery cable clip (red insulation)
E8	413-30	1	Lens
	214-201	1	Pickup unit
			<i>Consisting of:</i>
E9	214-188	1	<i>Pickup slide</i>
E10	214-200	1	<i>Right pickup housing</i>
E11	214-199	1	<i>Left pickup housing</i>
E12	258-191	1	Spring
E13	431-57	1	Terminal strip
E14	475-5	1	RF core
	85-1191-2	1	Circuit board
	390-388	1	Kit name label
	390-975	1	Kit model label
	391-34	1	Blue and white label
			Parts Order Form
			Kit Builders Guide
			Manual (See front cover for part number.)
			Solder



STEP-BY-STEP ASSEMBLY

Before starting to assemble this kit, be sure you have read the wiring, soldering, and step-by-step assembly information in the "Kit Builders Guide."

CIRCUIT BOARD ASSEMBLY

Components will be installed on the circuit board in the steps on Pages 7 through 10. Position all parts as shown in Pictorials 1 through 4. Follow the instructions carefully and read the entire step before performing each operation.

All resistors will be called out by resistance values (in Ω , $k\Omega$, or $M\Omega$).

Capacitors will be called out by capacitance value (in μF) and type (electrolytic, disc, or Mylar).

Locate the circuit board and position it lettered side up as shown in Pictorial 1. Then complete each step on Pictorial 1.

5A

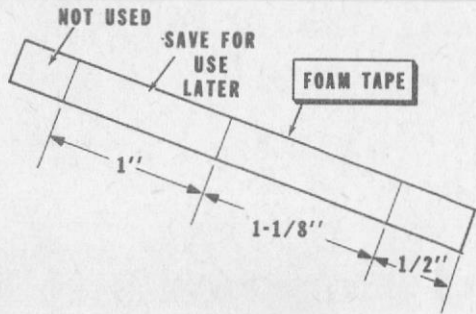

Detail 6B

PARTS PICTORIAL (Continued)

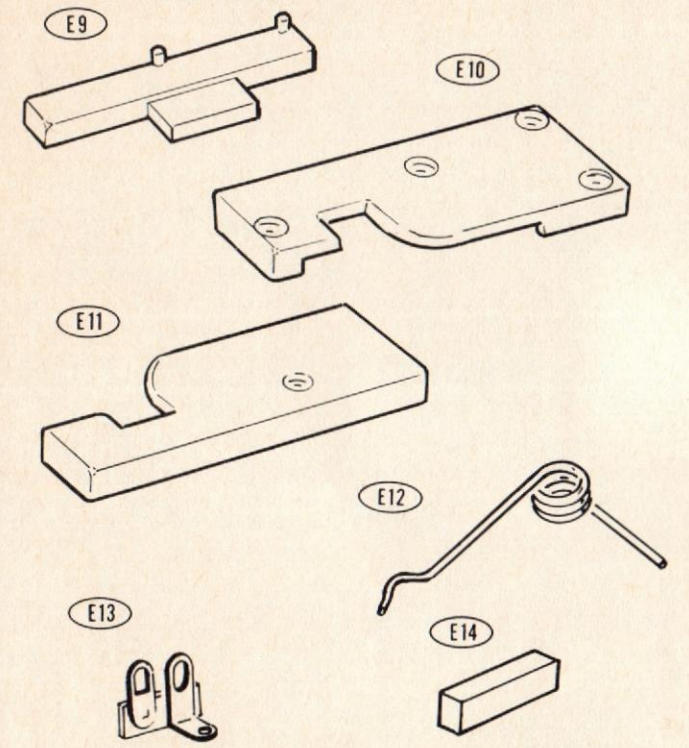
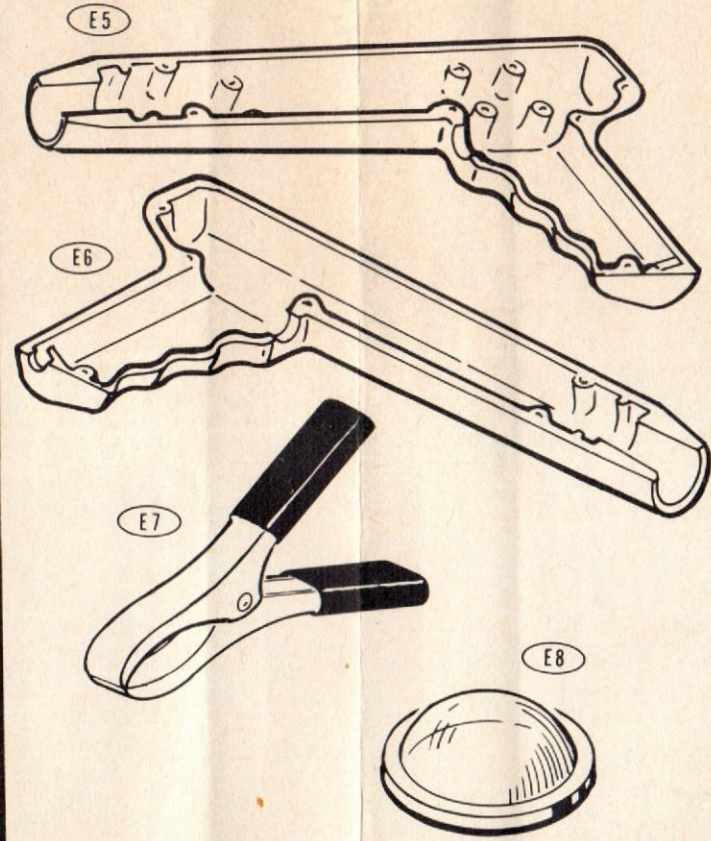
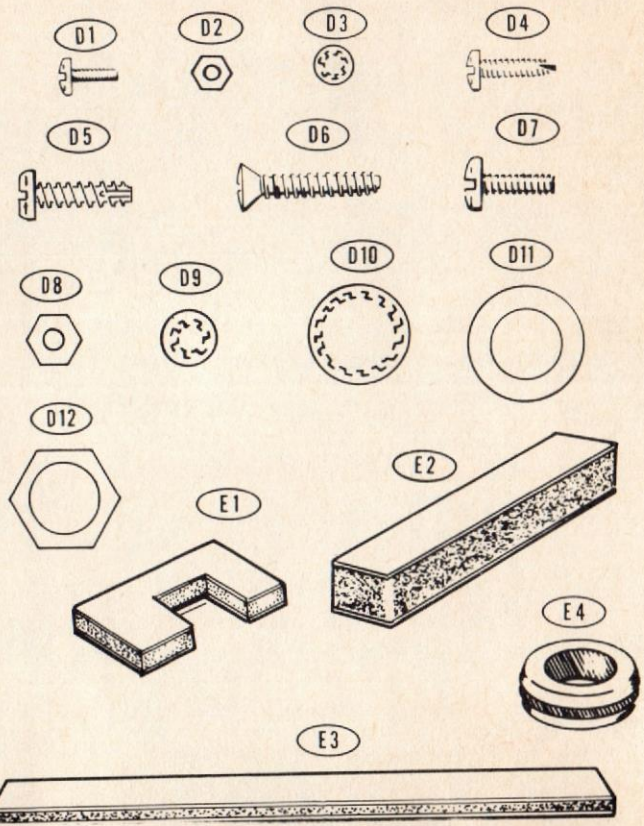

START



FOR GOOD SOLDERED CONNECTIONS, YOU MUST KEEP THE SOLDERING IRON TIP CLEAN.

WIPE IT OFTEN WITH A DAMP SPONGE OR CLOTH.



NOTE: When installing disc capacitors, remove any excess coating from the leads. Use long-nose pliers to remove this coating.



REMOVE COATING EVEN WITH BOTTOM OF CAPACITOR BODY.

(✓) .05 μ F disc.

(✓) .01 μ F disc.

(✓) .47 μ F Mylar.

(✓) 4 μ F electrolytic. Position the capacitor as shown with the positive lead in the positive (+) marked hole.

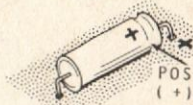

POSITIVE (+) END

() Solder all leads to the foil and cut off the excess lead lengths.



CONTINUE



(✓) 133 k Ω precision.

(✓) 1 M Ω precision.

(✓) 100 k Ω , 2-watt (brown-black-yellow).

(✓) 47 k Ω , 2-watt (yellow-violet-orange).

(✓) 22 Ω (red-red-black).

(✓) 68 Ω , 2-watt (blue-gray-black).

(✓) Solder all leads to the foil and cut off the excess lead lengths.

PICTORIAL 1

START



- (✓) Silicon controlled rectifier (#57-51).

NOTE: When installing the silicon controlled rectifier, place the A, G, and K leads of the rectifier in the corresponding A, G, and K holes in the circuit board. Position the silicon controlled rectifier 1/4" above the circuit board. Solder the leads to the foil and cut off the excess lead lengths.

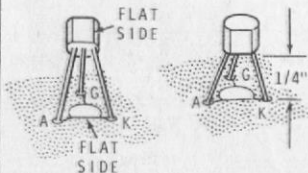

NOTE: DIODES MAY BE SUPPLIED IN ANY OF THE FOLLOWING SHAPES. THE CATHODE END OF THE DIODE IS MARKED WITH A BAND OR BANDS. ALWAYS POSITION THIS END AS SHOWN IN THE PICTORIAL.

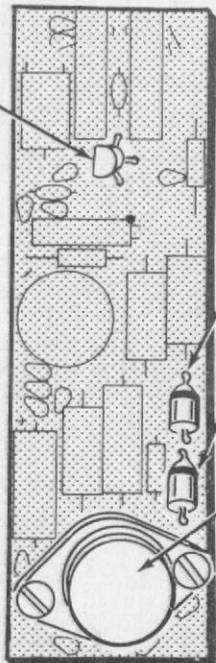
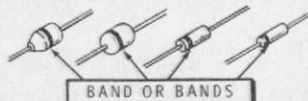

PICTORIAL 2

CONTINUE



- (✓) 1N2071 silicon diode (#57-27).

- (✓) 1N2071 silicon diode (#57-27).

- (✓) PNP transistor (#417-278).

Note that the two leads are closer to one end than to the other of the transistor body. Position the transistor so its leads match the holes marked B and E on the circuit board and so that it fits within the outline on the circuit board. Then install the transistor on the circuit board, using two 6-32 x 3/8" screws, two #6 lock-washers, and two 6-32 nuts.

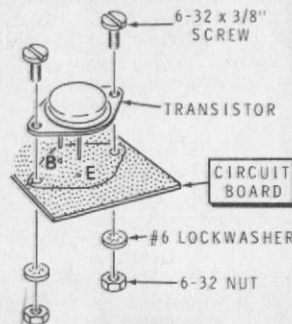

- (✓) Solder all leads to the foil and cut off the excess lead lengths.

START ↓

1 Trigger transformer (#40-1887). Place the green, red, and black transformer leads into the corresponding GRN, RED, and BLK holes in the circuit board. Do not cut or remove additional insulation from these leads. Solder the leads to the foil and cut off the excess lead lengths. Then position the transformer against the circuit board.

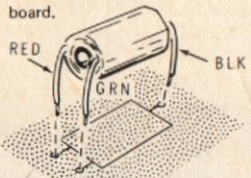

2 Neon lamp (#412-34). Position the neon lamp with the red mark as shown and bend the leads down. Then install the lamp with its red mark next to the black dot on the circuit board. Solder the leads to the foil and cut off the excess lead lengths.

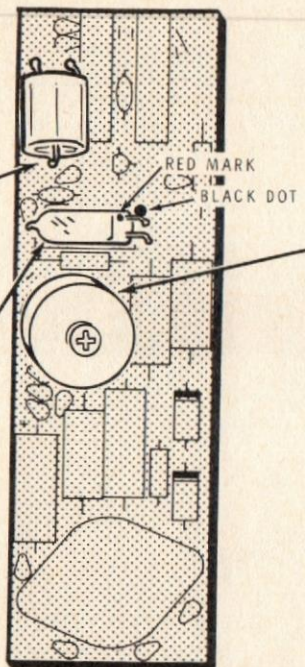

CONTINUE ↓

3 200 Ω control. Solder the control lugs to the foil and cut off the excess lead lengths.

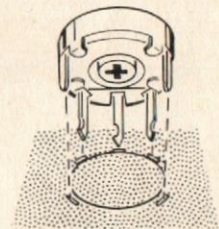

PICTORIAL 3

START

NOTE: Be careful in handling the strobe tube to prevent damage to the glass seal or the tube.

- (1) Bend the strobe tube leads into a half-circle as shown.

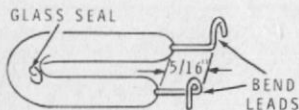

- (2) With the glass seal facing up, position the end of the strobe tube 1/2" from the edge of the circuit board. Then install the leads at K and L and solder them to the foil. Cut off the excess lead lengths.

NOTE: When bare wire is called for in the following steps, use the red hookup wire and cut it to the specified lengths; then remove all of the insulation.

The steps performed in this Pictorial are in this area of the circuit board.

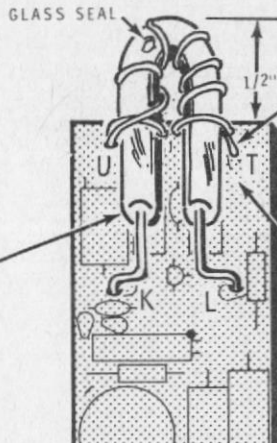

PICTORIAL 4

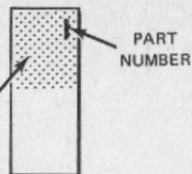

CONTINUE

- (1) Bend a 2" bare wire into a "U" shape. Install the wire in holes N and P over the strobe tube, and draw the wire snugly against the foil. Solder the wire ends to the foil and cut off the excess lengths.

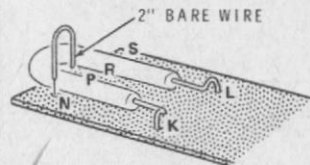

- (2) Bend another 2" bare wire into a "U" shape and repeat the previous step at holes R and S.

- (3) Insert one end of a 6" bare wire 1/4" into hole U. Solder this wire to the foil. Wrap the free end of this wire around the strobe tube five complete turns. Then insert the free end of this wire into hole T and solder it to the foil.

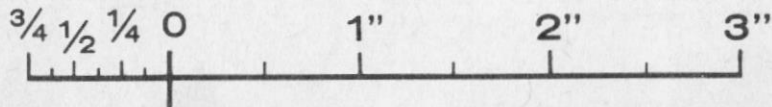
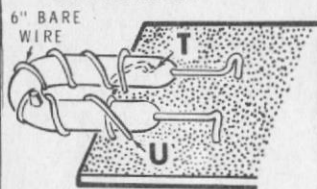

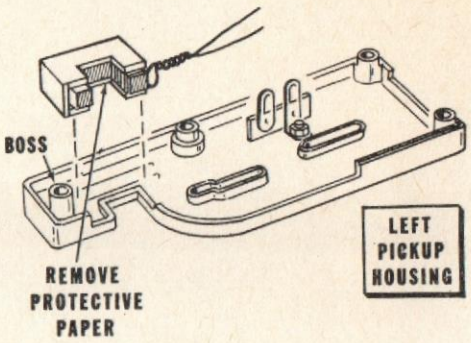

Detail 6D

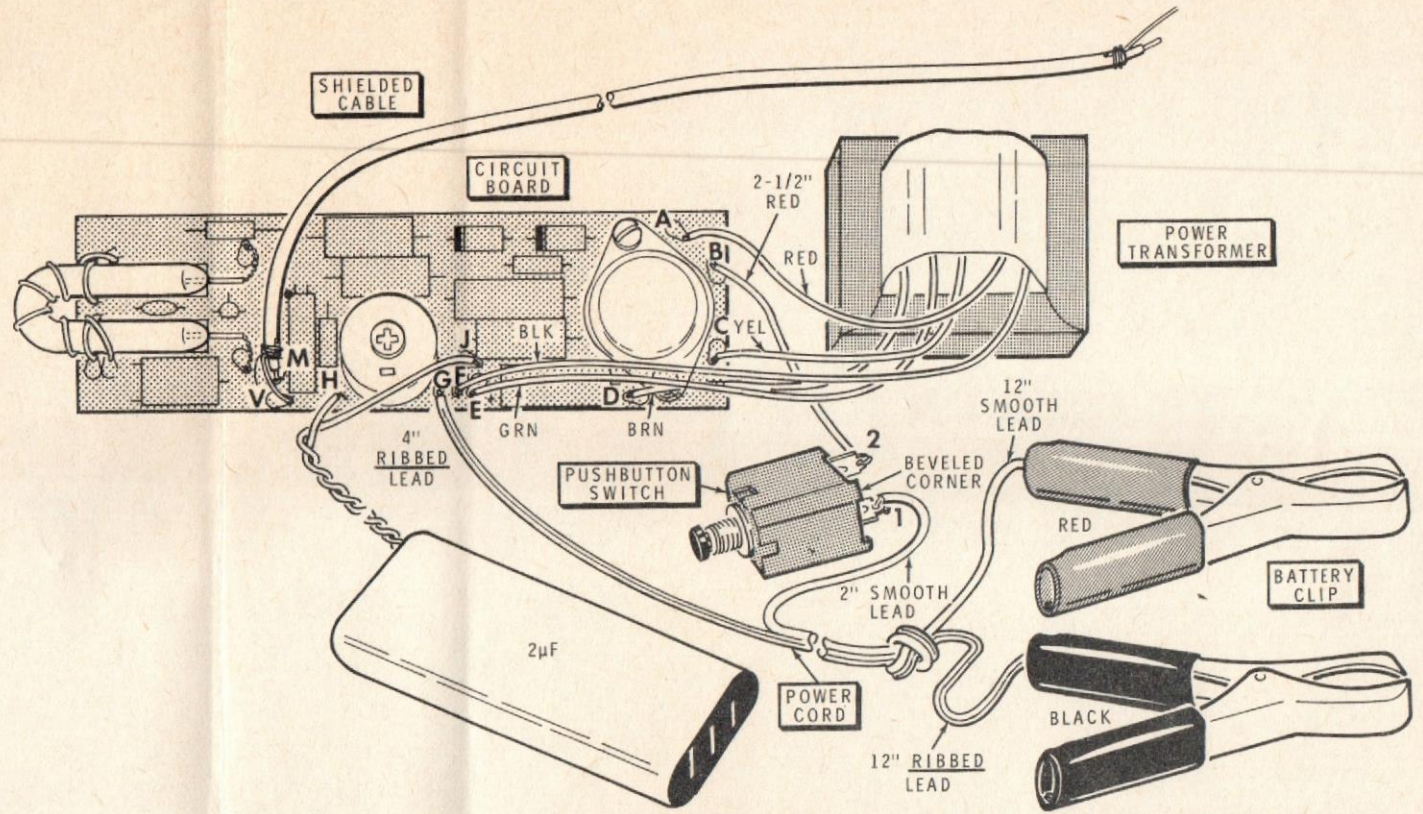

PICTORIAL 5

WIRING

Refer to Pictorial 5 (fold-out from Page 10) for the following steps.

- (✓) Twist the leads of the 2 μ F capacitor as shown.
- (✓) Connect either capacitor lead to circuit board hole J (S-1).
- (✓) Connect the other capacitor lead to circuit board hole H (S-1).

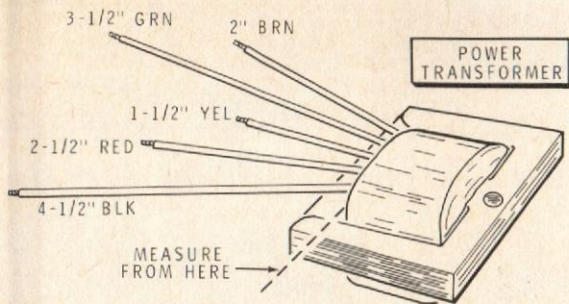

Detail 5A

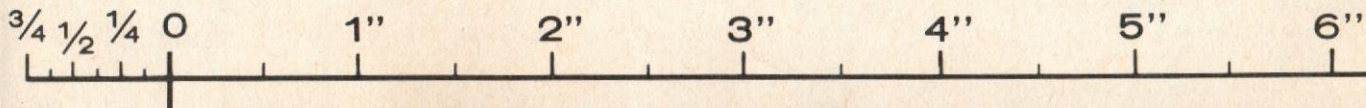

- (✓) Refer to Detail 5A and cut the power transformer leads to the indicated lengths. Measure the leads from where they come out of the transformer. Remove 1/4" of insulation from the end of each lead. Twist together the small strands of wire at the end of each lead; then melt a small amount of solder on each of the exposed ends.

Connect the transformer leads to the circuit board as follows:

- (✓) Black lead to hole F (S-1).
- (✓) Green lead to hole E (S-1).
- (✓) Brown lead to hole D (S-1).
- (✓) Yellow lead to hole C (S-1).
- (✓) Red lead to hole A (S-1).
- (✓) Cut a 2-1/2" length of red hookup wire and remove 1/4" of insulation from each end.
- (✓) Connect one end of this wire to circuit board hole B (S-1).
- (✓) Refer to Pictorial 5 and place the pushbutton switch near the circuit board. Position the beveled corner of the switch as shown. Connect the free end of the red wire to lug 2 of the switch (S-1).

- (✓) Refer to Detail 5B and prepare both ends of the power cord. Note that one power cord lead is identified with ribs, while the other lead is smooth.
- (✓) At the short end of the prepared power cord, connect the smooth 2" lead to lug 1 of the pushbutton switch (S-1).
- (✓) Connect the ribbed 4" lead to circuit board hole G (S-1). Then cut off the excess lead length.

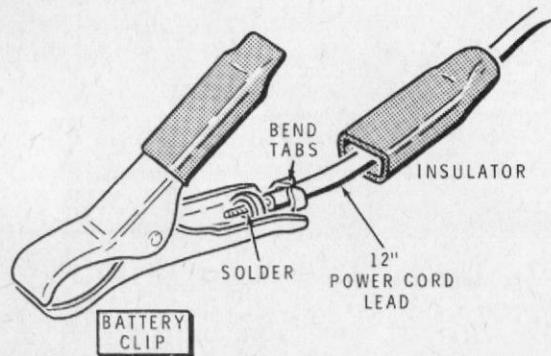

Detail 5C

- (✓) Refer to Detail 5C and locate the battery clip with the black insulators. Slide the insulator off one of the handles and onto the ribbed 12" power cord lead. Solder the lead to the solder lug of the handle and, after it has cooled, bend the tabs over the power cord insulation. Then slide the insulator onto the handle.

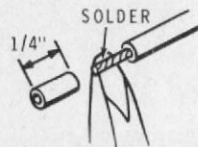
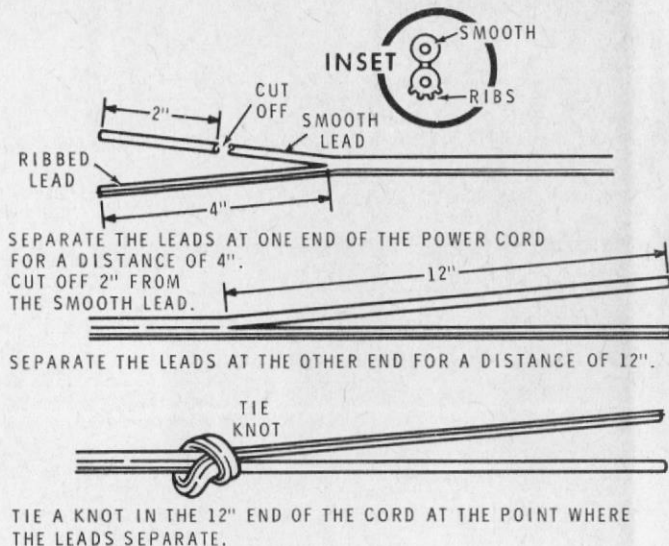

REMOVE 1/4" OF INSULATION FROM THE END OF EACH LEAD. TWIST THE SMALL STRANDS TOGETHER; THEN MELT A SMALL AMOUNT OF SOLDER ON THE EXPOSED WIRE ENDS.

Detail 5B

CUT THE CABLE ACCORDING TO THE DIMENSIONS BELOW. PREPARE EACH END AS SHOWN.

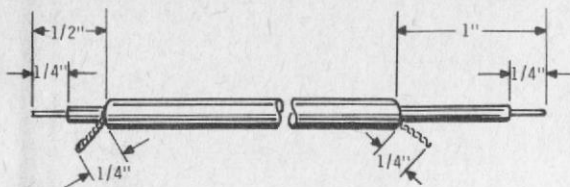

- ① TAKING CARE NOT TO CUT THE OUTER SHIELD OF VERY THIN WIRES, REMOVE THE OUTER INSULATION.

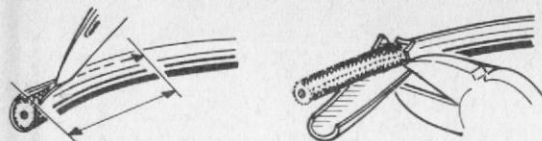

- ② UNBRAID THE SHIELD WITH A NAIL OR POINTED TOOL AND TWIST THE SHIELD WIRES INTO ONE STRAND. REMOVE 1/4" OF INSULATION FROM EACH OF THE INNER LEADS. APPLY A SMALL AMOUNT OF SOLDER TO THE END OF THE INNER LEAD. USE ONLY ENOUGH HEAT FOR THE SOLDER TO FLOW.

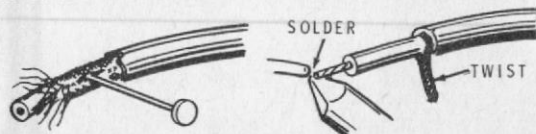

Detail 5D

- (✓) Likewise, install the battery clip with the red insulators on the smooth power cord lead.
 - (✓) Refer to Detail 5D and prepare both ends of the shielded cable as shown.
 - () Refer to Detail 5E and prepare the shield lead at both ends of this cable as shown.
- Connect the 1/2" end of the prepared shielded cable to the circuit board as follows:
- (✓) Inner lead to hole M (S-1). Cut off the excess lead length.
 - (✓) Shield lead to hole V (S-1). Cut off the excess lead length.
 - (✓) Carefully examine the circuit board foil to make sure all leads are soldered to the foil. Then cut off the excess lead lengths.

- ① BEND THE SHIELD BACK AND AGAINST THE OUTER INSULATION.

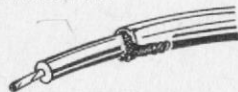

- ② WRAP A 2-1/2" BARE WIRE AROUND THE OUTER INSULATION AND SHIELD. THEN SOLDER THE BARE WIRE TO THE SHIELD.

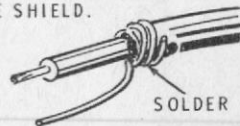

Detail 5E

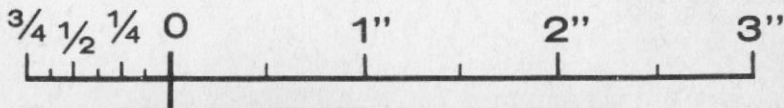

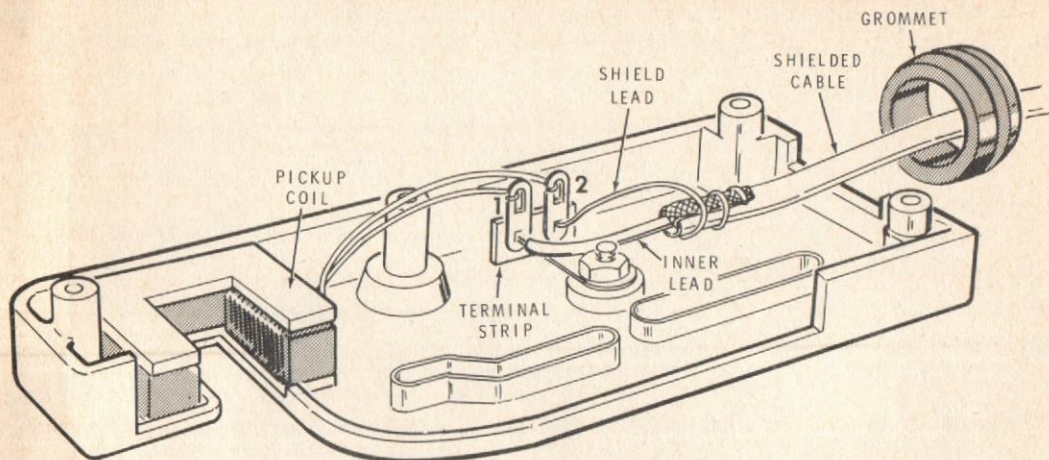

PICTORIAL 6

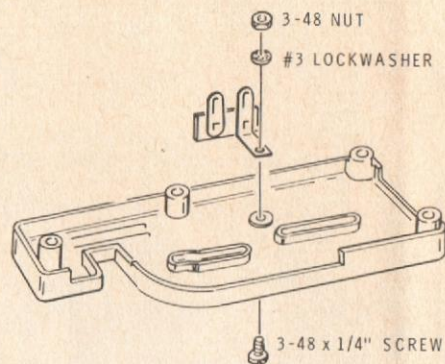

Detail 6A

Refer to Pictorial 6 for the following steps.

- (✓) Refer to Detail 6A and install the terminal strip in the left pickup housing. Use a 3-48 x 1/4" screw, a #3 lockwasher, and a 3-48 nut.
- (✓) Place a grommet on the free end of the shielded cable. Push the grommet back from the end of the cable and out of the way.

Connect the free end of the shielded cable to the terminal strip as follows:

- (✓) Shield lead to the eyelet in lug 2 (S-1).
- (✓) Inner lead to the eyelet in lug 1 (S-1).

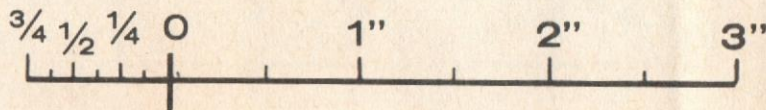

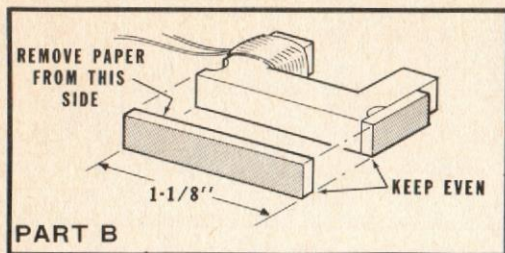
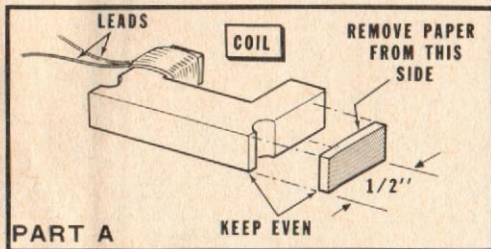

Detail 6C

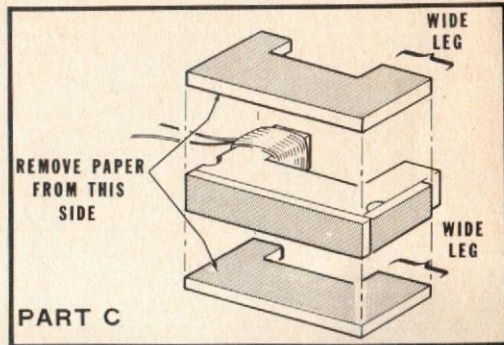

- (✓) Refer to Detail 6B (fold-out from Page 6) and cut the 3" length of foam tape into three pieces as shown.

NOTE: When you install the pieces of foam tape in the following steps, remove the protective paper from one side only.

- (✓) Refer to Part A of Detail 6C and position the pickup coil (#40-336) as shown. Then press the 1/2" piece of foam tape onto the pickup coil. Make sure the indicated end of the tape is even with the indicated edge of the pickup coil.

- (✓) Refer to Part B of Detail 6C and install the 1-1/8" piece of foam tape as shown.

- (✓) Refer to Part C of Detail 6C and remove the protective paper from the indicated side of a U-shaped piece of foam tape. NOTE THE POSITION OF THE WIDE LEG. Then press the tape onto the proper side of the coil.

- (✓) In the same manner, install the other U-shaped piece of foam tape on the other side of the coil. Be sure to remove the backing paper from the correct side of the foam tape.

- (✓) Refer to Detail 6D (fold-out from Page 10) and remove the protective paper from the indicated piece of foam tape. Then press the pickup coil into place in the left pickup housing as shown.

- (✓) L1: Connect either lead of the pickup coil to terminal strip lug 1 (S-1) and the other lead to terminal strip lug 2 (S-1). Do not shorten the leads. Position them down in the housing as shown.

This completes the wiring of the Timing Light. Check it to be sure all connections are soldered and that all excess lead lengths have been cut off.

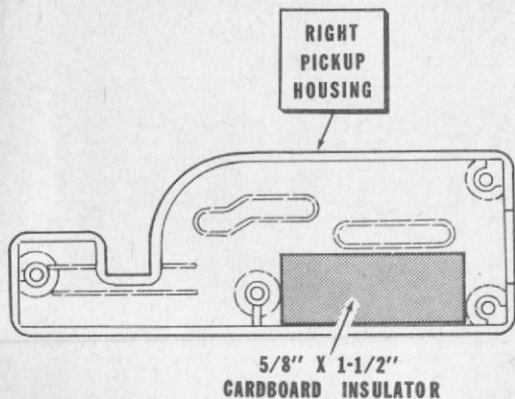

Detail 7A

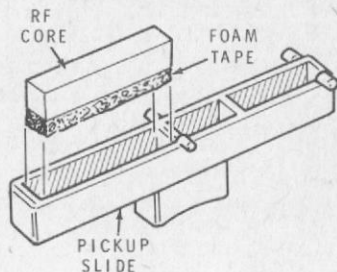

Detail 7B

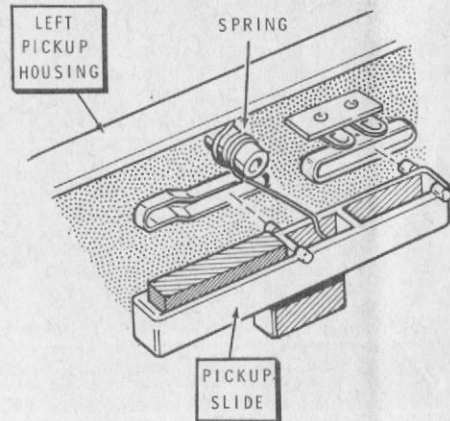

Detail 7C

Refer to Pictorial 7 (fold-out from Page 17) for the following steps.

- (✓) Cut a 5/8" x 1-1/2" piece of cardboard insulator. Then remove the paper backing and press the insulator into place in the right pickup housing as shown in Detail 7A.
- (✓) Remove the protective paper from one side of the saved 1" length of foam tape. Then press the tape onto any one of the long sides of the RF core. See Detail 7B.
- (✓) Refer to Detail 7B and remove the protective paper from the other side of the foam tape. Then press the RF core into the largest opening of the pickup slide.

- (✓) Place the grommet into the cutout in the end of the pickup housing.
- (✓) Refer to Detail 7C and install the spring and pickup slide in the left pickup housing. Operate the slide back-and-forth to be sure the leads are not in the way of the slide. If they are, move them out of the way so the slide works freely.
- (✓) Install the right pickup housing on the pickup assembly with #6 x 1/2" screws. Be sure the housing fits into the groove of the rubber grommet, and over the pickup coil and the pickup slide. Try operating the pickup slide. The slide should move about half its travel distance towards the end of the pickup. It is necessary to push the remaining distance.

COMPONENT HOUSING ASSEMBLY

Refer to Pictorial 8 (fold-out from this page) for the following steps.

- () Position the component half of the housing as shown.
- () Position the twisted capacitor leads under the circuit board, and place the circuit board and power transformer in the component housing as shown.
- () Install a 4-24 x 3/8" self-tapping screw at each corner of the circuit board. Carefully tighten each of these screws a little at a time to secure the circuit board to the housing. Do not overtighten these screws.
- () Mount the power transformer to the housing using 6-20 x 5/8" self-tapping screws.
- () Refer to Detail 8A and install the pushbutton switch in the component housing with a control lockwasher, a control flat washer, and a control nut. Position them so the nut and flat washer are on the outside of the housing and the lockwasher is on the inside of the housing.
- () Cut one length of 2" foam tape into two 1" lengths.
- () Position the 2 μ F capacitor so the twisted leads are on the left side of the capacitor as shown in the inset drawing.
- () Peel the paper backing from one side of a prepared length of foam tape. Press this length of tape onto one end of the 2 μ F capacitor as shown.
- () Likewise, press the other prepared length of foam tape onto the other end of the capacitor.

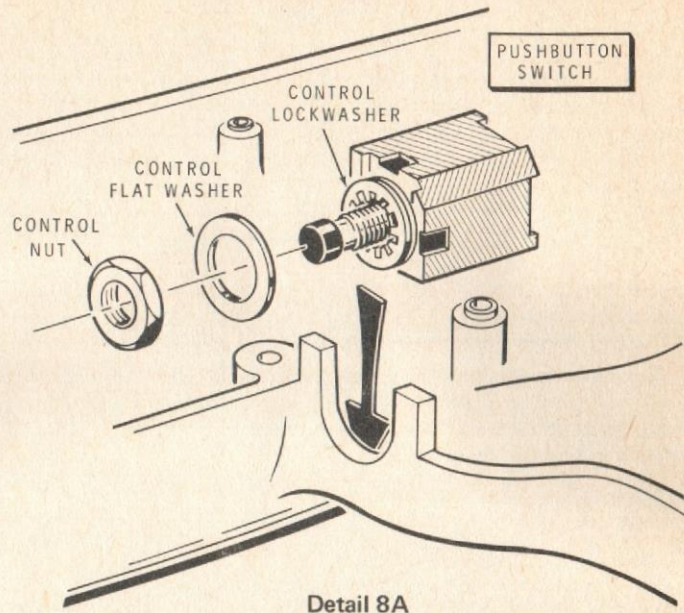

- () Peel the backing paper from the upper side of both lengths of foam tape. Then turn the capacitor over and press it into the housing handle. Be sure the upper edge of the capacitor is positioned away from the pushbutton switch.

This completes the assembly of the component housing. Proceed to "Adjustments."

ADJUSTMENTS

Use one of the two procedures below to adjust the Automotive Timing Light. Reliable operation will be obtained if you use the steps entitled "Adjustments Using the Neon Lamp." A slight increase in strobe tube intensity may be obtained if you use a DC voltmeter and the steps under "Adjustments Using a DC Voltmeter."

DANGER! SHOCK HAZARD

Avoid contact with the two leads of the strobe tube when the battery clips are connected to the battery.

NOTE: If you do not obtain the proper response in the following adjustments, refer to the "In Case of Difficulty" section on Page 26 to locate and correct the trouble. After you locate the trouble and correct it, return to this section of the Manual and complete the adjustments.

ADJUSTMENTS USING THE NEON LAMP

Refer to Figure 1 for the following steps.

- () Temporarily secure the trigger pickup cable and the power cord to the handle with a rubber band or masking tape. This will prevent the shielded cable and the power cord from breaking where they connect to the circuit board.

- () Using a small screwdriver, turn the 200 Ω control fully clockwise.

NOTE: In the following steps, you can use a separate 15 volt DC power supply (of at least 1.5 ampere capacity), or the battery of your automobile with the engine running.

- () Connect the black battery clip to the negative (-) terminal of your power supply or to the negative terminal of the battery in your automobile.
- () Connect the red battery clip to the positive (+) terminal of the power supply or to the positive terminal of the battery.
- () Hold the pushbutton switch pressed in (a faint squealing sound is normal) and slowly rotate the 200 Ω control counterclockwise until the small neon lamp just begins to glow.
- () Release the pushbutton switch and disconnect the battery clips.
- () Remove the rubber band or masking tape holding the trigger pickup cable and the power cord to the handle.

This completes "Adjustments Using the Neon Lamp." Proceed to "Final Assembly."

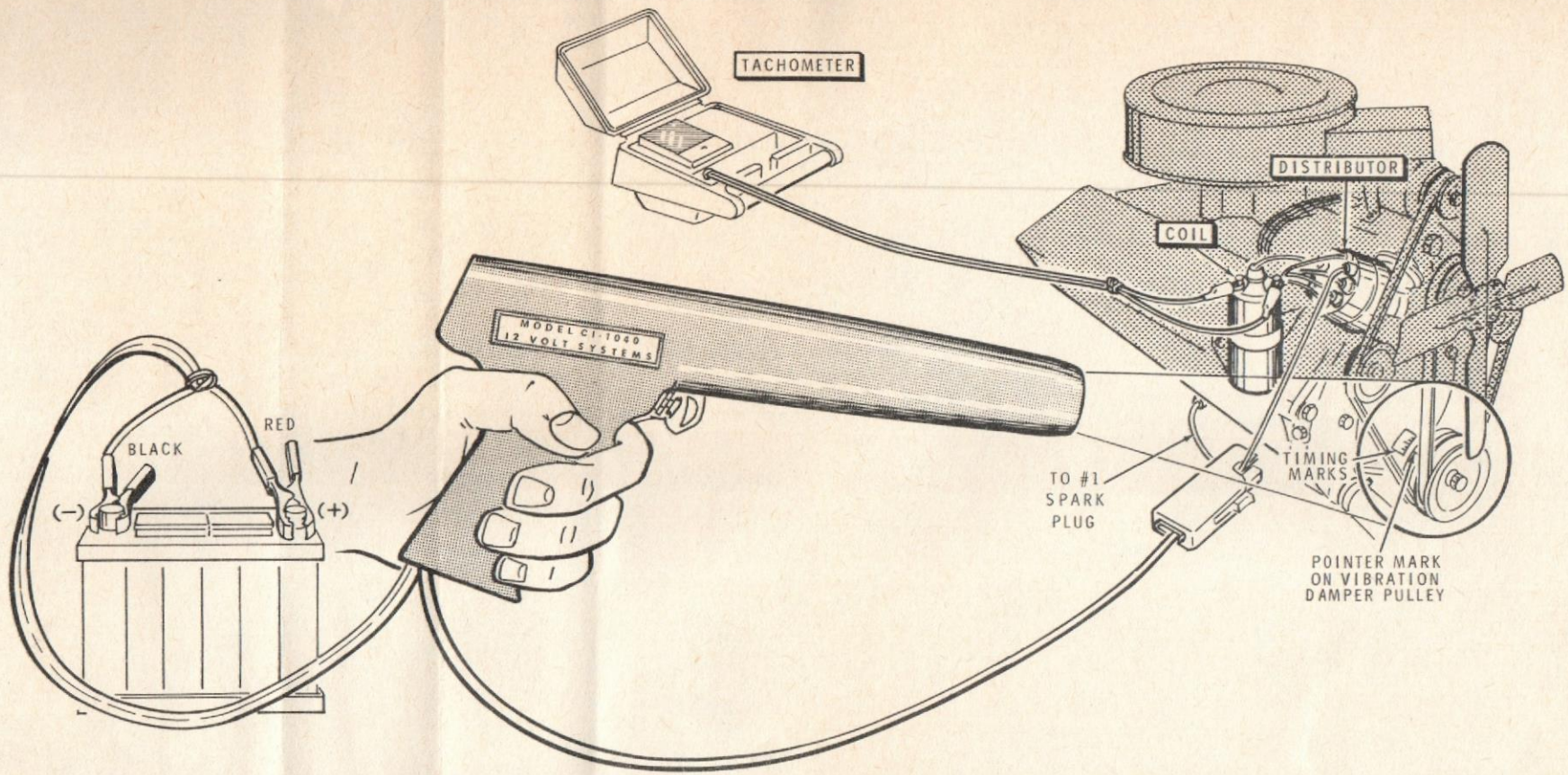
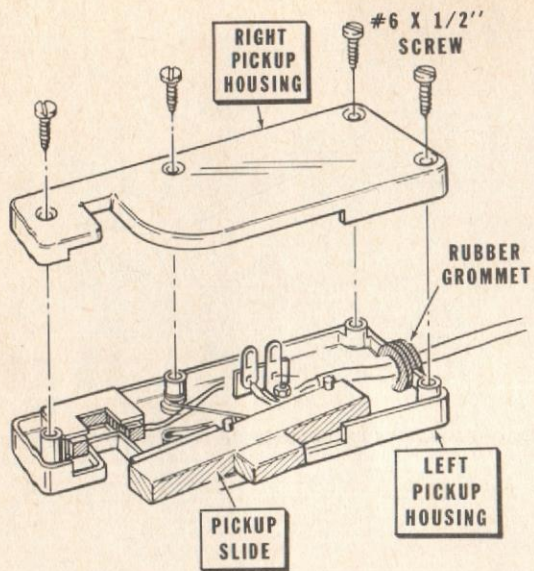
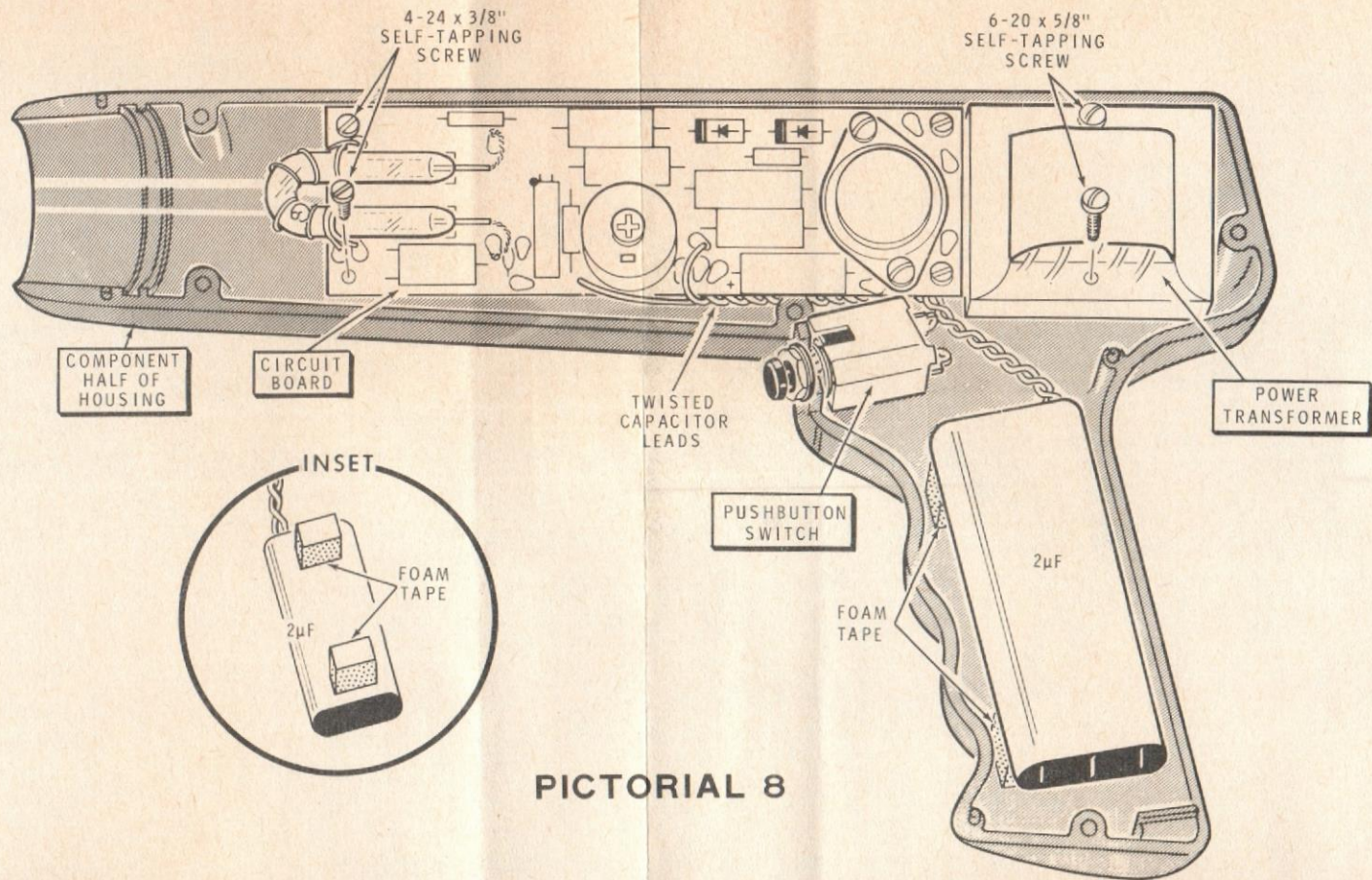

Figure 3



PICTORIAL 7



PICTORIAL 8

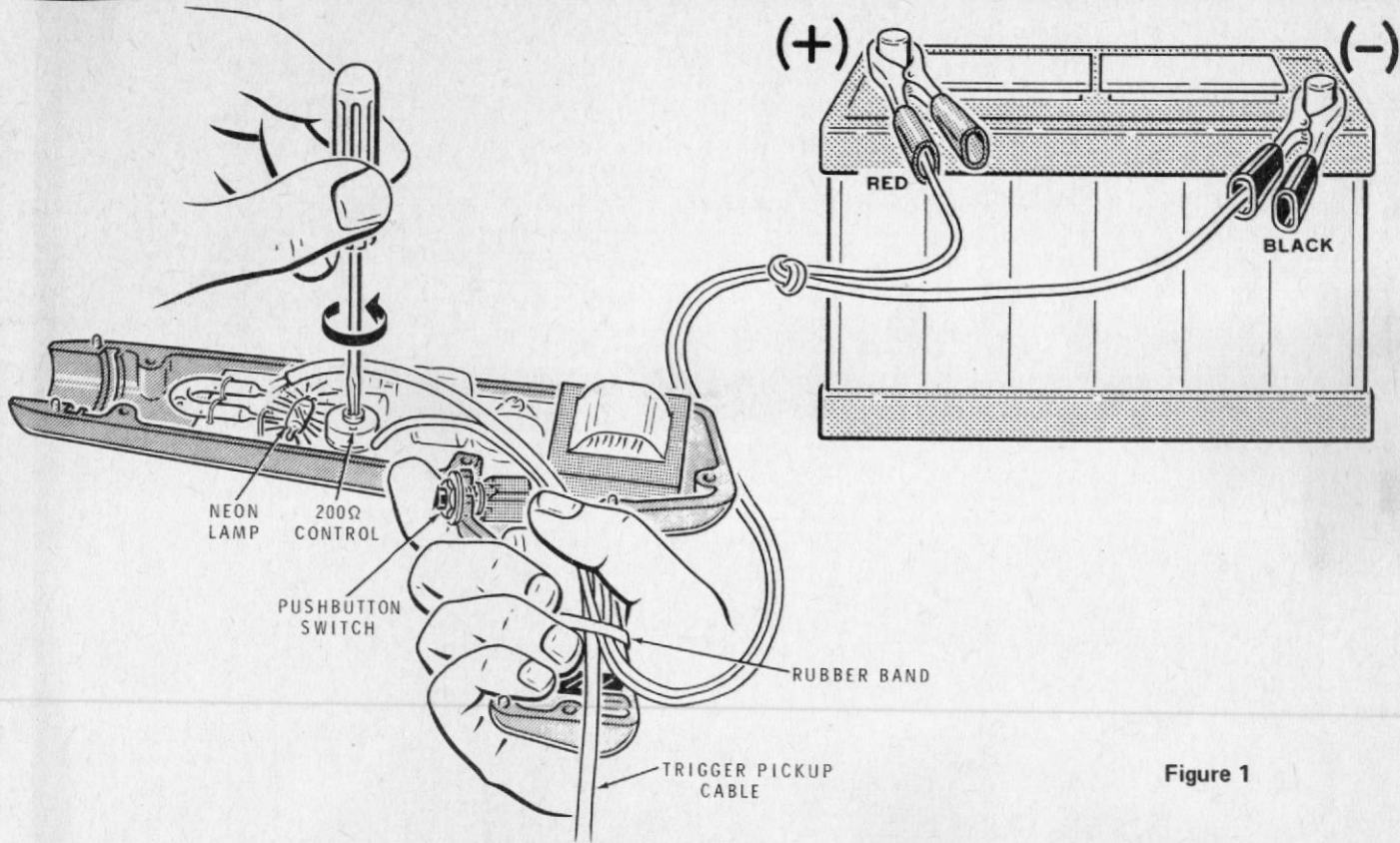

Figure 1

ADJUSTMENTS USING A DC VOLTMETER

Refer to Figure 2 for the following steps.

- () Temporarily secure the triggering pickup cable and the power cord to the handle with a rubber band or masking tape while performing the following adjustments. This will prevent the shielded cable and power cord from breaking where they connect to the circuit board.
- () Using a small screwdriver, turn the 200 Ω control fully clockwise.
- () Connect the negative (-) voltmeter lead to the strobe tube lead at point K, and connect the positive (+) voltmeter lead to point L.

NOTE: In the following steps, you can use a separate 15 volt DC power supply (of at least 1.5 ampere capacity), or the battery of your automobile (with the engine running).

- () Connect the black battery clip to the negative (-) terminal of your power supply or to the negative terminal of the battery in your automobile.
- () Connect the red battery clip to the positive (+) terminal of the power supply or to the positive terminal of the battery.
- () Hold the pushbutton switch pressed in (a faint squealing sound is normal) and slowly rotate the 200 Ω control counterclockwise until the DC voltmeter reads 600 volts.
- () Release the pushbutton switch and disconnect the battery clips. Also disconnect the DC voltmeter leads from the strobe tube at points L and K.
- () Remove the rubber band or masking tape holding the trigger pickup cable and the power cord to the handle.

This completes the "Adjustments." Proceed to "Final Assembly."

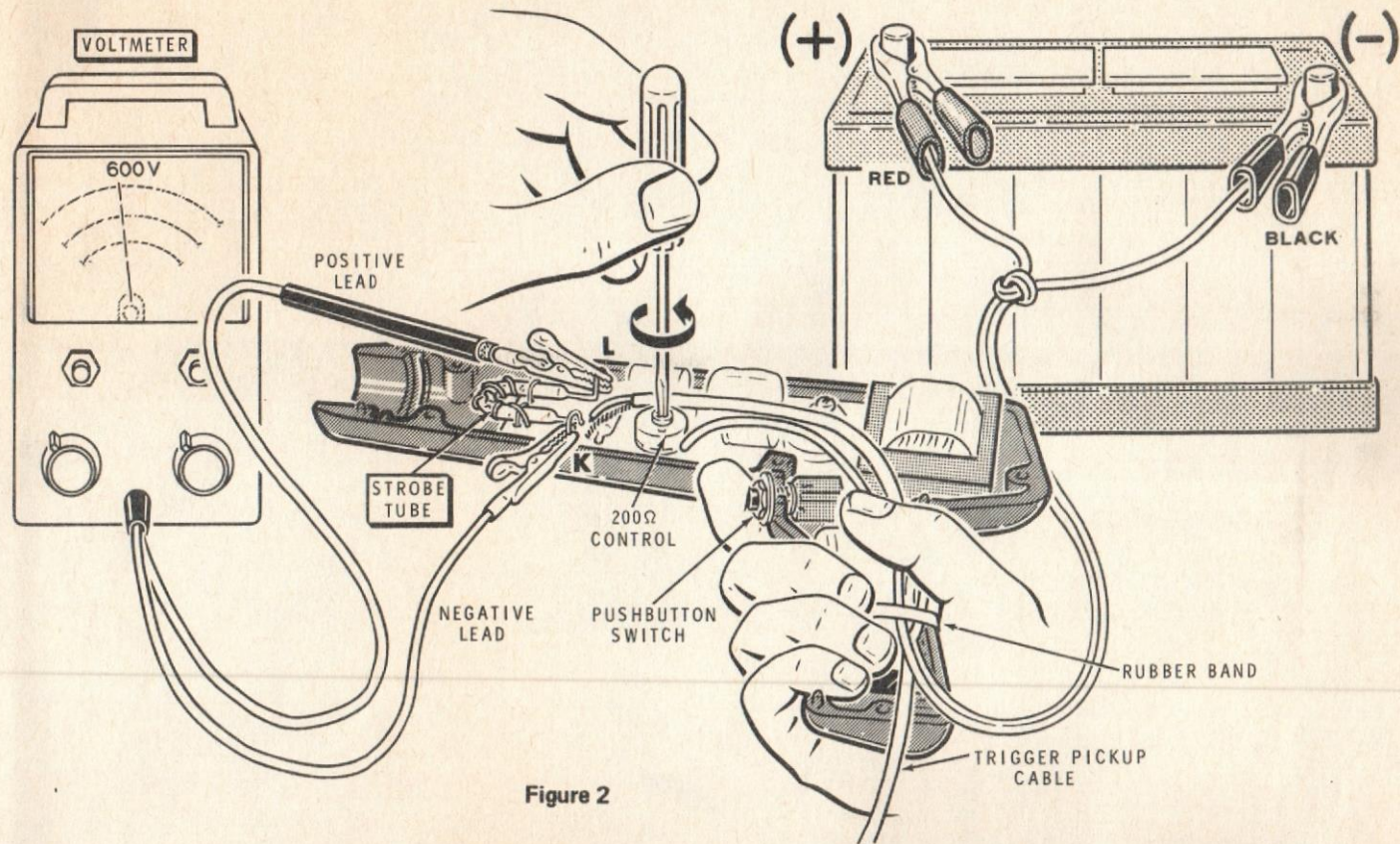
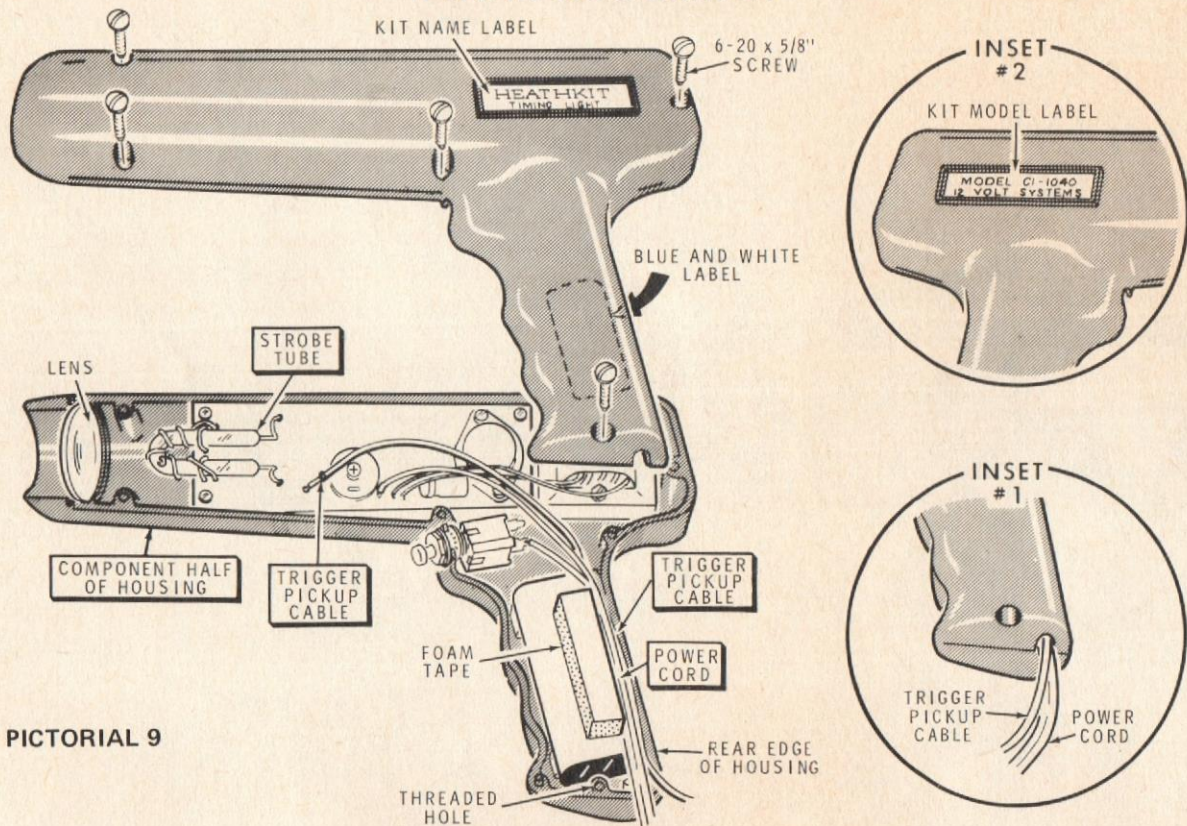
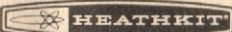

Figure 2

FINAL ASSEMBLY





Locate the blue and white label and the Registration Card. Then record the series number (printed on the blue and white label) in the proper place on the Registration Card.

Refer to Pictorial 9 for the following steps.

Carefully peel away the backing paper from the blue and white identification label. Then press the label on the inside of the housing half at the location shown. Be sure to refer to the numbers on this label in any communications you have with the Heath Company about this kit.

Peel the backing from only one side of the remaining length of 2" foam tape. Press the tape onto the 2 μ F capacitor at the location shown.

Place the lens in the component half of the housing with the flat side of the lens facing the strobe tube.

Route the power cord and the trigger pickup cable past the pushbutton switch and the foam tape on the capacitor as shown. Locate the cord and the cable between the threaded hole in the handle and the rear edge of the housing.

Route the green and black transformer wires over the 4 μ F electrolytic capacitor and away from the edge of the component housing. Then carefully place the housing half over the lens, the pushbutton switch, the power cord, and the trigger pickup cable.

Position the power cord and the trigger pickup cable in the cutout of the housing half as shown in inset drawing #1. Be sure the housing half is positioned so it matches the component half before performing the next step.

Install the five 6-20 x 5/8" screws in the housing half and carefully tighten them a few turns at a time. Do not overtighten the screws.

Carefully remove the backing paper from the kit name label. Press the label in place in the recessed area of the barrel as shown.

Carefully remove the backing from the kit model label. Press the label in place in the recessed area on the opposite side of the housing as shown in inset drawing #2.

NOTE: When not in use, wrap the power cord and high voltage cable in a "Figure 8" around the handle and barrel of the Timing Light as shown in Pictorial 10.

This completes the assembly of your Timing Light.

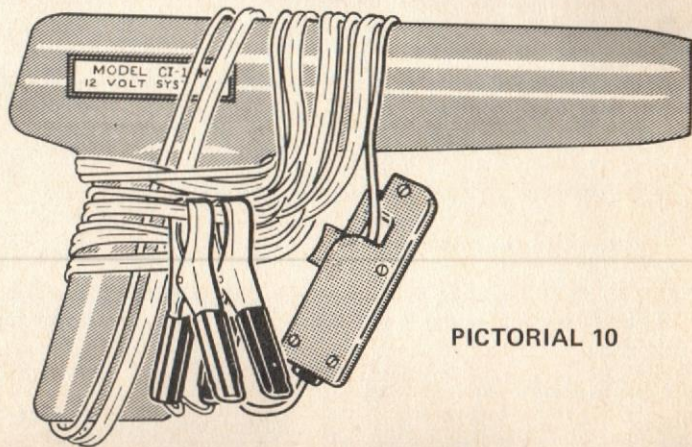

PICTORIAL 10

OPERATION

Refer to Figure 3 (fold-out from Page 18) for an illustration of the operation and use of the Timing Light on an automobile engine.

NOTE: It may be helpful to refer to technical publications, books, and magazines for additional timing information and techniques.

ENGINE TIMING SPECIFICATIONS

Obtain the timing specifications for your car's engine before attempting any timing adjustments.

If you wish, record your car's specifications on the "Engine Timing Specifications Chart" on the fold-out from Page 36.

PRECAUTIONS

While doing engine timing, avoid personal injury or damage to the Timing Light, its power cord, and the trigger pickup lead by observing the following precautions:

1. Avoid touching any high voltage points on the engine ignition system.
2. Keep away from the fan and the fan belt.
3. Be sure the Timing Light, its power cord, and the trigger pickup cable are correctly positioned as shown in Figure 3 so they are clear of the fan and fan belt.
4. Avoid touching the exhaust manifold of the engine.

5. Do not lay the Timing Light on the engine.
6. Do not look directly at the lens of the Timing Light when it is operating.
7. Do not let the trigger clamp snap shut.

OPERATING CONSIDERATIONS

The following considerations apply to using the Timing Light:

1. The Timing Light can be used in daylight at a range of up to two feet from the timing marks.
2. The pushbutton switch should not be taped down. Use the pushbutton switch only when doing timing adjustments or when checking the timing.
3. Do not attempt to do timing adjustments until other engine tuning work has been completed.
4. Operating the engine at over 2,000 rpm, with the Timing Light hooked up to the ignition system, will cause a loss of brightness in the Timing Light and cause its components to overheat. Operation of the Timing Light at engine speeds over 2,000 rpm should only be intermittent.
5. The Timing Light should not be used in temperatures below 0° F. The electronic components may be damaged.

TIMING PROCEDURE EXAMPLE

Read through this section completely before attempting to time your engine.

Refer to Figure 4 (fold-out from this page) for an illustration of the hookup of the Timing Light to an automobile ignition system.

NOTE: The following basic step-by-step procedure is only an example.

1. Refer to the engine timing specifications.
2. Start the engine and allow it to warm up to normal operating temperature.
3. Use a tachometer to set the engine to the specified idle rpm.
4. Connect the trigger pickup around the #1 spark plug lead.
5. Connect the battery clip with black insulation to the negative (-) battery terminal. Connect the battery clip with red insulation to the positive (+) battery terminal. (DO NOT MAKE A CONNECTION TO THE COIL.)
6. Refer to the engine timing specifications for your particular engine and disconnect the vacuum line if required.

WARNING: The stroboscopic effect of the Timing Light that causes the timing mark to appear "stopped," also causes other revolving parts (fan, fan belt, and pulleys) to appear stopped. DO NOT place your hands near these supposedly "stopped" parts.

7. Aim the Timing Light at the timing marks and press the pushbutton switch.
8. If the timing reference mark lines up with the specified timing mark, no adjustment is necessary. Turn the engine off. However, if the reference mark does not line up with the timing mark, the engine needs timing. Proceed to step 9.
9. NOTE: Do not rotate the distributor after loosening the locking screw. (If you wish, mark the position of the distributor before loosening the screw so you can return it to the original adjustment point.)

Turn the engine off. Then carefully loosen the locking screw on the distributor clamp. Leave the screw tight enough so that the distributor will not change position by itself while the engine is running.

10. Start the engine.
11. Rotate the distributor until the timing reference mark lines up with the specified timing mark.
12. Tighten the distributor locking screw and then recheck the engine timing using the Timing Light.
13. NOTE: If the distributor of your engine has a centrifugal spark advance perform this step. If it does not have a centrifugal spark advance, disregard this step and proceed to step 14.

Increase the engine speed smoothly and observe the timing marks with the Timing Light aimed at them. The matching timing mark should move as the engine speed is increased. The direction of movement of the timing mark should be opposite to the direction of rotation of the damper pulley.

14. Reconnect the vacuum line if it was disconnected and plugged as required by the engine timing specifications.
15. Set the engine speed at higher than normal idle speed. While the Timing Light is aimed at the timing marks, open the throttle suddenly and then let it spring closed. The matching timing marks will momentarily move in the direction of rotation of the engine (retards spark) when the engine is suddenly speeded up. With normal speed increases, the vacuum control advances the spark and adds to the spark advance caused by the centrifugal advance mechanism. A sudden increase in engine speed causes the intake manifold vacuum to drop to a low value which momentarily retards the spark.

IN CASE OF DIFFICULTY

Refer to the "Identification Photograph" on Page 36 and the "Circuit Board X-Ray View" on Page 35 for help in locating parts on the circuit board.

1. Recheck the wiring. Trace each lead in colored pencil on the Pictorial as it is checked. It is frequently helpful to have a friend check your work. Someone who is not familiar with the unit may notice something consistently overlooked by the builder.
2. About 90% of the kits that are returned for repair do not function properly due to poor connections and soldering. Therefore, many troubles can be eliminated by carefully checking all connections to make sure they are soldered as described in the "Soldering" section of the "Kit Builders Guide."
3. Check the values of the parts. Be sure that the proper parts have been wired into the circuits at each location.
4. Check electrolytic capacitors and diodes to be sure they are installed properly, with the marked end of each one positioned as it is shown in the Pictorial.

5. Check for bits of solder, wire ends, or other foreign matter which may be lodged in the wiring, or for solder bridges between foils on the circuit board.
6. Check the transistor and SCR with a transistor tester or by substitution of a transistor of the same type known to be good.
7. A review of the "Circuit Description" may also help you locate a difficulty.

NOTE: In an extreme case where you are unable to resolve a difficulty, refer to the "Customer Service" information inside the rear cover of the Manual. Your Warranty is located inside the front cover.

TROUBLESHOOTING PROCEDURE

Difficulties with the Timing Light (see Troubleshooting Chart) are due to:
1. The Timing Light, 2. The hookup to the ignition system, or 3. The engine or ignition system.

Troubleshooting Chart

PROBLEM	POSSIBLE CAUSE
Strobe tube does not light (no squealing sound).	<ol style="list-style-type: none"> 1. Connections to battery. 2. Oscillator transistor Q1. 3. SW1.

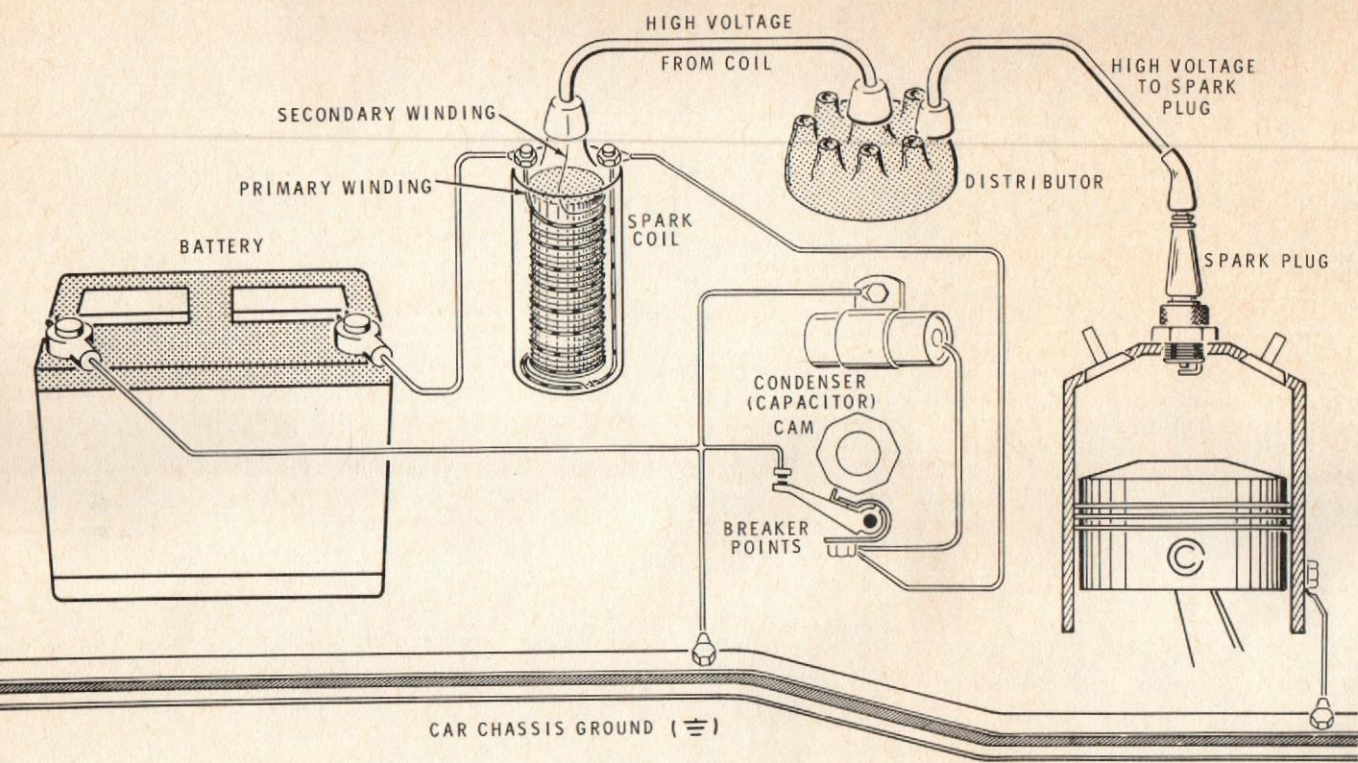
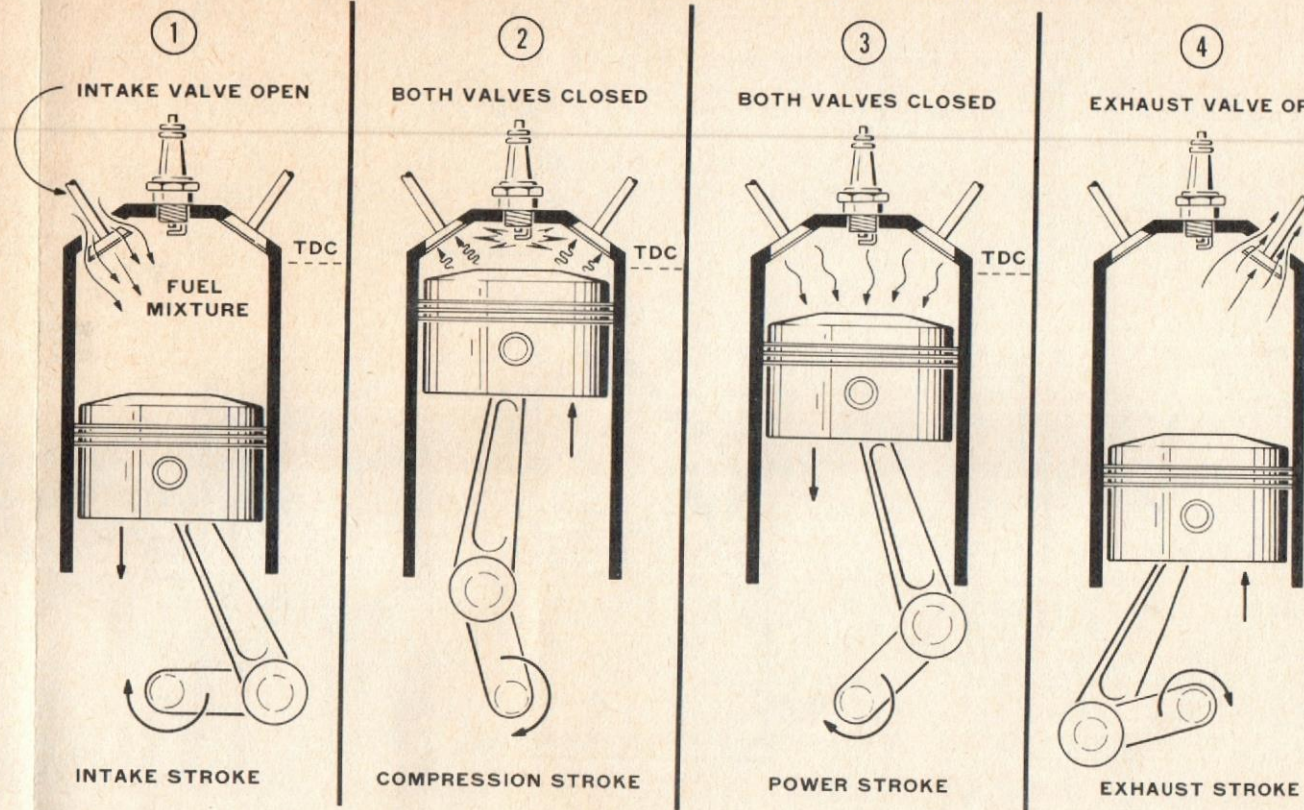

Figure 8

PRINCIPLE OF OPERATION OF 4-CYCLE (STROKE) ENGINE



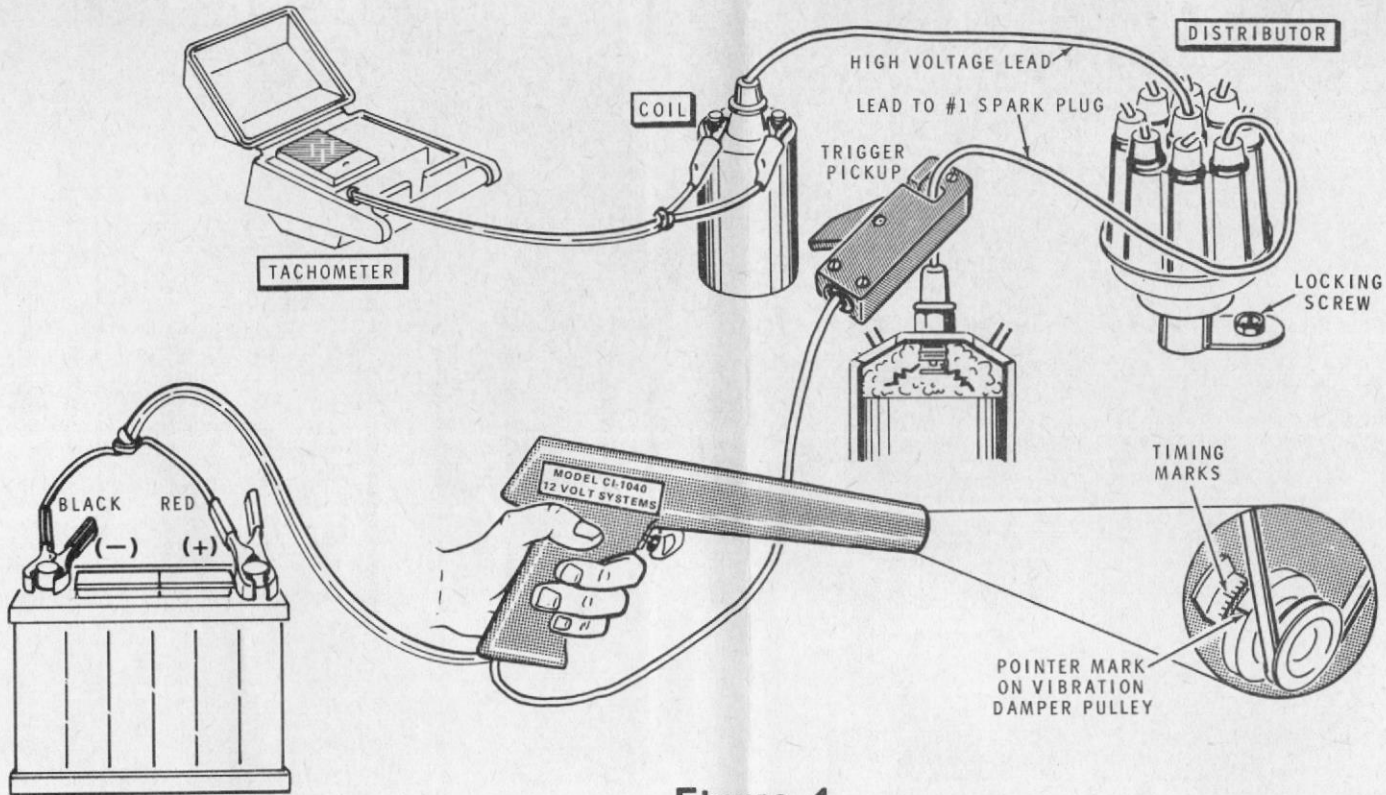

Figure 4

PROBLEM	POSSIBLE CAUSE
Strobe tube does not light (squealing sound can be heard).	<ol style="list-style-type: none">1. Incorrect connection to spark plug lead.2. Distributor lead broken or insulation on lead broken.3. #1 spark plug not firing. (Place the trigger pickup on another spark plug lead to check the strobe tube.)4. No voltage on strobe tube.5. SCR.6. Strobe tube faulty.
Strobe tube lights only dimly.	<ol style="list-style-type: none">1. Low voltage to strobe tube (check R1 calibration control adjustment).2. Strobe tube faulty.
Strobe tube flashes do not correspond to firing of #1 spark plug.	<ol style="list-style-type: none">1. Trigger pickup connected to incorrect spark plug lead and distributor lead. (Check the engine specifications for correct plug to be used in engine timing.)
Strobe tube turns black or light is hard to see.	<ol style="list-style-type: none">1. Replace strobe tube.

SPECIFICATIONS

Useful Light Range	Up to 2 feet in daylight.
Engine Speed Range	Full flash brightness up to 2000 rpm. Operation above 2000 rpm should be intermittent only.
Triggering	Current pickup coil.
Connecting Cables	Battery cable with clips (7 feet). Trigger pickup cable with clip (5 feet).
Power Requirements	12 volt automotive storage battery or separate 15 volt DC power supply with 1.5 ampere capacity.
Size	6-1/2" high x 10" long x 2" wide.
Weight	1 lb. 8 oz.

The Heath Company reserves the right to discontinue products and to change specifications at any time without incurring any obligation to incorporate new features in products previously sold.

THEORY OF ENGINE OPERATION

HOW TIMING WORKS

This section of the Manual explains the principles of operation of a 4-cycle engine (used in most automobiles). To understand how ignition timing works in an engine, read this section thoroughly.

Refer to Figure 5 (fold-out from Page 26) for an illustration of the basic principle of operation of a 4-cycle (4 strokes per cycle) engine. Only the #1 cylinder of the engine is shown. All the other cylinders of the engine operate in the same manner, going through the same four strokes per cycle as the #1 cylinder does. The sequence of operation of the other cylinders is determined by the engine design and by the firing order of the engine.

① Intake Stroke

On the intake stroke, the piston moves down, the exhaust valve closes, and the intake valve of the engine opens, admitting the fuel mixture to the engine.

② Compression Stroke

On the next stroke, the intake valve closes, and the piston moves up toward the head of the engine to compress the fuel mixture. At a certain "timed" instant, as the piston is still moving up, the spark plug fires and ignites the fuel. The distributor determines the timing of the spark.

③ Power Stroke

The fuel mixture, which has been ignited by the spark plug, requires approximately 1/350th of a second to burn completely. Depending on the speed at which the engine is operating, the fuel will still be burning for a certain amount of time after the piston reaches "top dead center" (TDC) and has started down on the power stroke. The force of expansion of the burning fuel pushes the piston down and gives the engine its power.

④ Exhaust Stroke

When the piston moves up again, the exhaust valve opens, releasing the burned fuel. This prepares the engine to take in fuel again for the intake stroke which follows the exhaust stroke.

Top Dead Center

The crankshaft of the engine rotates through 180 degrees for each stroke of the piston. At the highest point of piston travel, the piston is at "top dead center" (TDC). All ignition timing, as specified by the engine manufacturer, is measured in degrees of crankshaft rotation from the point where the piston is at top dead center.

ENGINE TIMING SETTINGS

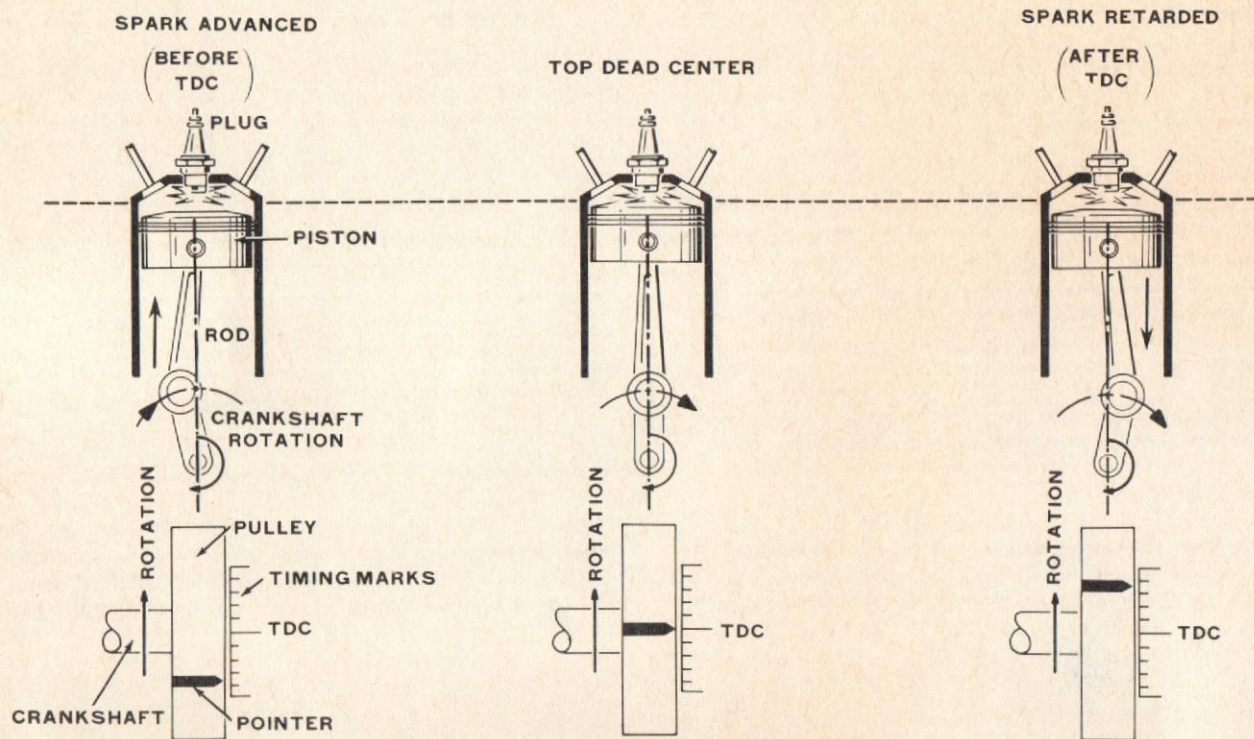

Figure 6

Advancing or Retarding the Spark (Distributor Adjustment)

As shown in Figure 6, the time when the spark plug fires can be changed by manually adjusting the distributor. The terms "advanced" and "retarded" are used to designate the direction in which the spark timing is being changed. Causing the spark to occur at a point earlier in the rotation of the crankshaft is "advanced" and later is "retarded." The spark is advanced or retarded automatically by the centrifugal and automatic vacuum advance sections of the distributor. (See "Operation" on Page 24.) The centrifugal spark advance mechanism works from the speed of the engine. It advances the breaker cam of the distributor as the engine is speeded up. The automatic vacuum spark advance works from engine vacuum. It advances the distributor breaker plate with an increase in engine speed. When the throttle is opened suddenly, the vacuum spark control momentarily retards the spark to allow the engine to run smoothly.

Using the Timing Marks on the Engine

Figure 7 shows example timing marks on an engine. These marks are calibrated to the angular rotation of the crankshaft relative to the position of the piston in the #1 cylinder before or after TDC. With the engine running, a timing light is aimed at the timing marks. Due to the stroboscopic effect, the pointer mark (or pointer) will appear to line up with one of the calibrated timing marks. The timing mark which matches the pointer mark indicates the position of the spark during the stroke of the piston in the #1 cylinder only.

What the Timing Light Does

The strobe tube of the Timing Light is fired by the current induced into the trigger pickup coil when the #1 spark plug fires. The flash of the Timing Light illuminates the rotating damper pulley, and the timing marks, when the firing voltage for #1 spark plug occurs at the distributor as shown in Figure 8 (fold-out from Page 26). As the pulley passes the timing marks, the pointer or mark on the pulley will appear to align with one of the timing marks. If the engine needs timing, the distributor is adjusted (by rotating the distributor housing) so that the pulley mark then aligns with the proper timing mark as specified by the engine manufacturer. NOTE: On some engines, the timing marks are located on the vibration damper pulley and the reference mark is a stationary pointer located near the pulley.

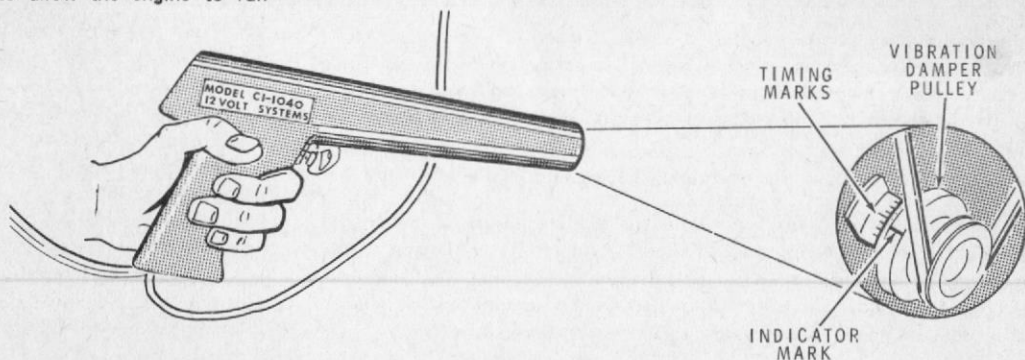

Figure 7

CIRCUIT DESCRIPTION

Refer to the Block Diagram, and the Schematic (fold-out from Page 35) as you read the following descriptions.

TIMING LIGHT

The voltage from the storage battery of the car is applied through switch SW1 to oscillator transistor Q1. R1, the 100 Ω control in the base circuit of Q1, varies the bias voltage of Q1. This bias voltage controls the oscillation frequency of Q1 and thus Q1's output, a pulsating dc to the primary winding of converter transformer T1, is controlled. This pulsating dc induces 600 volts AC in the secondary winding of T1.

The output voltage of T1 is applied to diodes D1 and D2, which operate as half-wave rectifiers and change the 600 volts AC to a pulsating DC voltage. The 2 μ F capacitor, C3, charges to the 600 volts, which is also applied to strobe tube V1. The tube does not fire at this time because the voltage is less than the self-ionization voltage of the tube. A voltage in the form of a trigger pulse is taken from the #1 spark plug lead of the engine when the plug fires.

A trigger pulse applied to the gate (G) of the SCR (D3) causes it to conduct. Capacitor C4 then discharges through trigger transformer L1. L1 steps up this voltage to the potential necessary to ionize the strobe tube. The tube then conducts, which allows capacitor C3 to discharge through the tube. A brilliant flash is produced that is approximately 10 microseconds in duration.

Resistors R4 and R5 form a voltage divider network for the voltage adjustment using the Neon lamp and control R1.

AUTOMOTIVE IGNITION SYSTEM

As shown in Figure 8 (fold-out from Page 26), the ignition system of an automobile engine consists of the spark coil, the distributor, and the spark plugs. Voltage for the system is provided by the storage battery. This voltage is applied to one end of the primary (low voltage) winding of the spark coil. The primary winding is also connected to the breaker points of the distributor. A lead (high voltage) from the secondary winding of the spark coil is connected to the distributor rotor. From the distributor, individual high voltage leads connect to each of the spark plugs of the engine.

When the distributor breaker points are closed, current flows through the points and the primary of the ignition coil. This causes a magnetic field to build up in the coil. Then, as the points are opened (by the distributor shaft cam), the current stops flowing and the magnetic field collapses — creating a high voltage (approximately 20,000 volts) in the secondary winding of the coil. This voltage is conducted to the spark plugs through the distributor rotor and distributor leads. The specific timing (instant the plug fires) is set by adjusting the distributor. The Timing Light is used to stroboscopically illuminate the timing marks (scale of degrees) on the engine and thus to determine accurately the angular position of the crankshaft when the spark plug fires. Engine timing specifications state at what position (in degrees of rotation relative to TDC) the spark plug should fire for proper timing.

BLOCK DIAGRAM OF TIMING LIGHT CIRCUIT

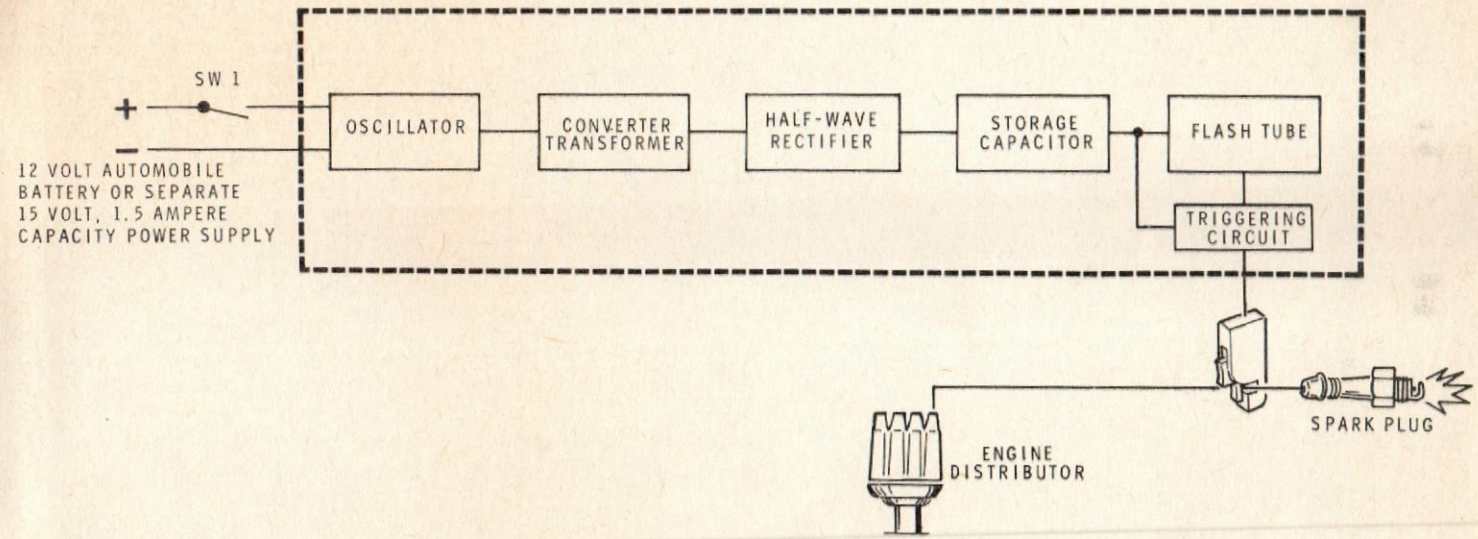

CIRCUIT BOARD X-RAY VIEW

NOTE: To determine the value (22 Ω , 4 μ F, etc.) of one of these parts, you may proceed in either of the following ways.

1. Refer to the place where the part is installed in the Step-by-Step instructions.

2. Note the identification number of the part (R-number, C-number, etc.). Then locate the same identification number next to the part on the Schematic. The value, or "Description," of most parts will be near this number.

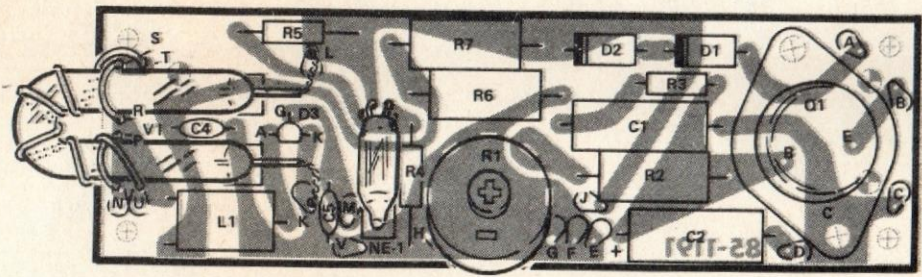

IDENTIFICATION PHOTOGRAPH

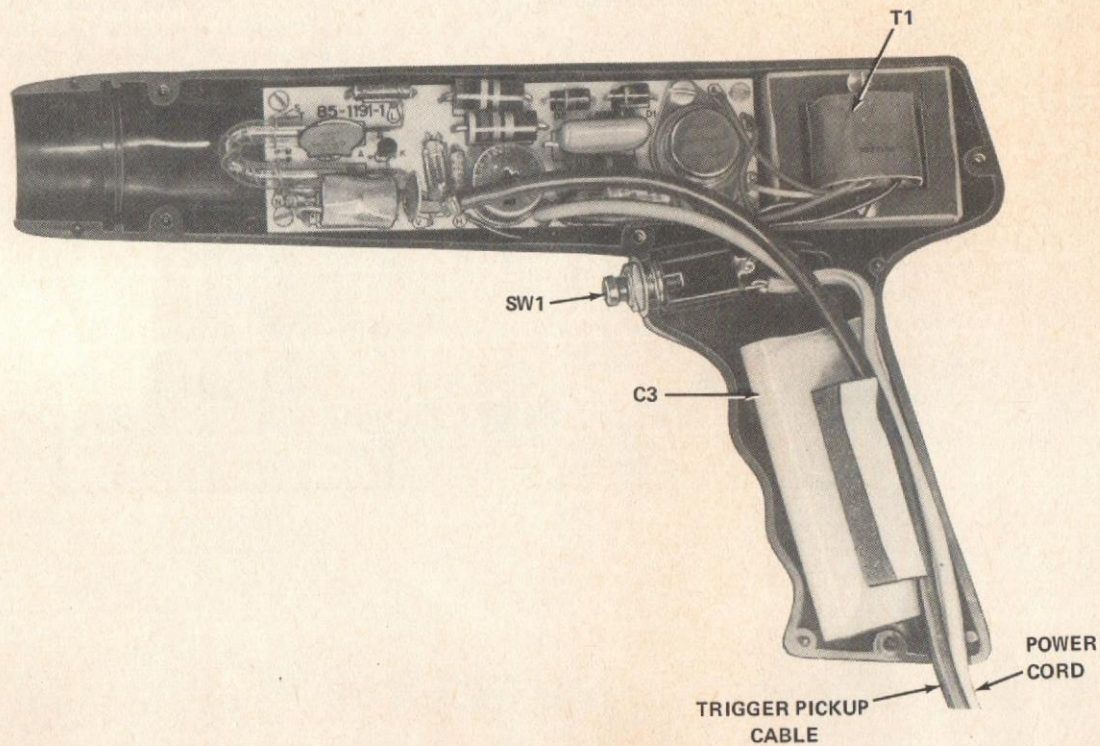

ENGINE TIMING SPECIFICATIONS CHART

CAR			IGNITION TIMING			DEGREES PER TIMING MARK	VACUUM SPARK ADVANCE LINE DISCONNECTED		IDLE SPEED (RPM)	TRANSMISSION SELECTOR		LOCATION OF #1 SPARK PLUG
YR.	MAKE	MODEL AND ENGINE	$^{\circ}$ BTDC ₁	TDC ₂	$^{\circ}$ ATDC ₃		YES	NO		NEUTRAL	DRIVE	

1. BTDC = BEFORE TOP DEAD CENTER
2. TDC = TOP DEAD CENTER (Highest point of piston travel in cylinder).
3. ATDC = AFTER TOP DEAD CENTER

OTHER SPECIFICATIONS _____

NOTES _____

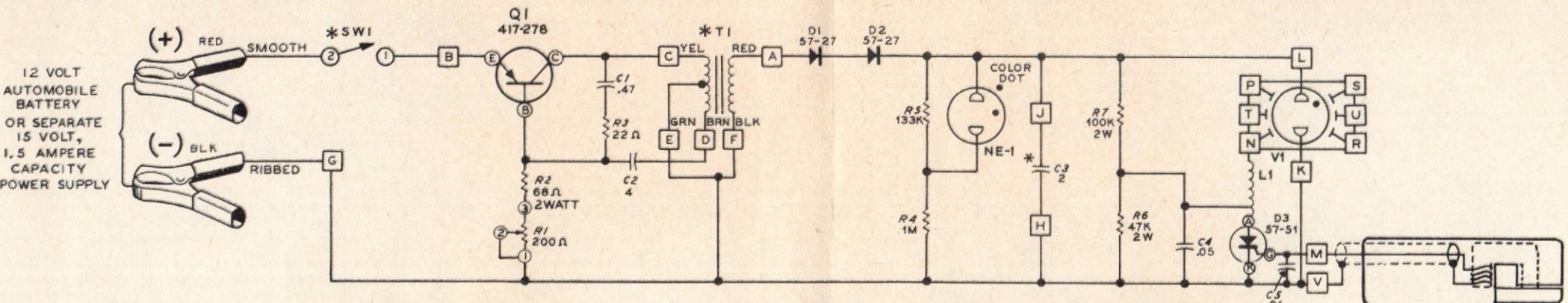

12 VOLT
AUTOMOBILE
BATTERY
OR SEPARATE
15 VOLT,
1.5 AMPERE
CAPACITY
POWER SUPPLY

BASING DIAGRAM
(BOTTOM VIEW)

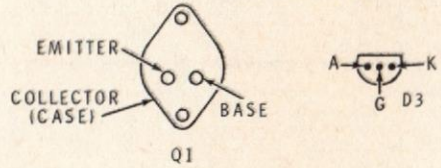

**SCHEMATIC OF THE
HEATHKIT®
12-VOLT AUTOMOTIVE
DELUXE TIMING LIGHT
MODEL CI-1040**

SCHEMATIC NOTES:

1. RESISTOR VALUES ARE IN OHMS (K=1000). RESISTORS ARE 1/2 WATT UNLESS OTHERWISE SPECIFIED.
2. ALL CAPACITOR VALUES ARE IN μ F.
3. □ THIS SYMBOL INDICATES CONNECTION TO CIRCUIT BOARD.
4. * ITEMS NOT ON CIRCUIT BOARD.

L2*
TRIGGER
PICKUP COIL

CUSTOMER SERVICE

REPLACEMENT PARTS

Please provide complete information when you request replacements from either the factory or Heath Electronic Centers. Be certain to include the **HEATH** part number exactly as it appears in the parts list.

Replacement parts are maintained specifically to repair Heath products. Parts sales for other reasons will be declined.

ORDERING FROM THE FACTORY

Print all of the information requested on the parts order form furnished with this product and mail it to Heath. For telephone orders (parts only) dial 616 982-3571. If you are unable to locate an order form, write us a letter or card including:

- Heath part number.
- Model number.
- Date of purchase.
- Location purchased or invoice number.
- Nature of the defect.
- Your payment or authorization for COD shipment of parts not covered by warranty.

Mail letters to: Heath Company
Benton Harbor
MI 49022
Attn: Parts Replacement

Retain original parts until you receive replacements. Parts that should be returned to the factory will be listed on your packing slip.

OBTAINING REPLACEMENTS FROM HEATH ELECTRONIC CENTERS

For your convenience, "over the counter" replacement parts are available from the Heath Electronic Centers listed in your catalog. Be sure to bring in the original part and purchase invoice when you request a warranty replacement from a Heath Electronic Center.

TECHNICAL CONSULTATION

Need help with your kit? — Self-Service? — Construction? — Operation? — Call or write for assistance, you'll find our Technical Consultants eager to help with just about any technical problem except "customizing" for unique applications.

The effectiveness of our consultation service depends on the information you furnish. Be sure to tell us:

- The Model number and Series number from the blue and white label.
- The date of purchase.
- An exact description of the difficulty.
- Everything you have done in attempting to correct the problem.

Also include switch positions, connections to other units, operating procedures, voltage readings, and any other information you think might be helpful.

Please do not send parts for testing, unless this is specifically requested by our Consultants.

Hints: Telephone traffic is lightest at midweek — please be sure your Manual and notes are on hand when you call.

Heathkit Electronic Center facilities are also available for telephone or "walk-in" personal assistance.

REPAIR SERVICE

Service facilities are available, if they are needed, to repair your completed kit. (Kits that have been modified, soldered with paste flux or acid core solder, cannot be accepted for repair.)

If it is convenient, personally deliver your kit to a Heathkit Electronic Center. For warranty parts replacement, supply a copy of the invoice or sales slip.

If you prefer to ship your kit to the factory, attach a letter containing the following information directly to the unit:

- Your name and address.
- Date of purchase and invoice number.
- Copies of all correspondence relevant to the service of the kit.
- A brief description of the difficulty.
- Authorization to return your kit COD for the service and shipping charges. (This will reduce the possibility of delay.)

Check the equipment to see that all screws and parts are secured. (Do not include any wooden cabinets or color television picture tubes, as these are easily damaged in shipment. Do not include the kit Manual.) Place the equipment in a strong carton with at least **THREE INCHES** of resilient packing material (shredded paper, excelsior, etc.) on all sides. Use additional packing material where there are protrusions (control sticks, large knobs, etc.). If the unit weighs over 15 lbs., place this carton in another one with 3/4" of packing material between the two.

Seal the carton with reinforced gummed tape, tie it with a strong cord, and mark it "Fragile" on at least two sides. Remember, the carrier will not accept liability for shipping damage if the unit is insufficiently packed. Ship by prepaid express, United Parcel Service, or insured Parcel Post to:

Heath Company
Service Department
Benton Harbor, Michigan 49022

HEATH

Schlumberger

PANY • BENTON HARBOR, MICHIGAN
S FINEST ELECTRONIC EQUIPMENT IN KIT FORM

LITHO IN U.S.A.