

\*\*\*\*\*

\* NOTES ON CD TECHNOLOGY AND REPAIR OF CD PLAYERS AND CDROM DRIVES \*

\* \* \* \* \*  
\* \* \* \* \* Version 2.50 \* \* \* \* \*  
\* \* \* \* \*  
\* Copyright (C) 1994,1995,1996 \*  
\* Samuel M. Goldwasser \*  
\* Corrections or suggestions to: sam@stdavids.picker.com \*  
\* \* \* \* \*  
\* --- All Rights Reserved --- \*  
\* \* \* \* \*  
\* Reproduction of this document in whole or in part is permitted \*  
\* if both of the following conditions are satisfied: \*  
\* \* \* \* \*  
\* 1. This notice is included in its entirety at the beginning. \*  
\* 2. There is no charge except to cover the costs of copying. \*  
\* \* \* \* \*

\*\*\*\*\*

\*\*\*\*\* INTRODUCTION \*\*\*\*\*

Compact discs and the digital audio revolution:

The transformation of CD players and CDROMs from laboratory curiosities to the economical household appliances that have revolutionized the musical recording industry and have made possible multimedia computing depend on the availability of two technologies: low power low cost solid state laserdiodes and mass produced large scale integrated circuits. Without these, a CD player using 1960's technology would be the size of dishwasher!

Most of us take all of this for granted rarely giving any thought to the amazing interplay of precision optics and complex electronics - at least until something goes wrong. The purpose of this document is to provide enough background on CD technology and troubleshooting guidance so that anyone who is reasonably handy whether a homeowner, experimenter, hobbieist, tinkerer, or engineer, can identify and repair many problems with CD players and possibly laserdisc players, CDROM drives, and optical storage drives as well.

Even if you have trouble changing a light bulb and do not know which end of a soldering iron is the one to avoid, reading through this document will enable you to be more knowledgeable about your CD player. Then, if you decide to have it professionally repaired, you will have a better chance of recognising incompetence or down right dishonesty when dealing with the service technician. For example, a bad laser is not the most likely problem - it is actually fairly far down on the list of typical faults. There - you learned something already!

Most of the information in this document applies to the CD players in component stereo systems, compact stereos, boomboxes, car units and portables, as well as CDROM drives. The primary differences will relate to how the disc is loaded - portables usually are top loaders without a loading drawer.

However, as a result of the level of miniaturization required for portables and to a lesser extent, CDROM drives, everything is tiny and most or all of the electrical components are surface mounted on both sides of an often inaccessible printed circuit board with the entire unit assembled using screws with a mind of their own and a desire to be lost.

Laserdisc players and optical disk storage units have much in common with CD players with respect to the mechanical components and front-end electronics. Therefore, the information contained in this document can represent a starting point for their troubleshooting as well.

Many common problems with CD players can be corrected without the need for the service manual or the use of sophisticated test equipment. The types of problems in a CD player can be classified as:

1. Mechanical - dirt, lubrication, wear, deteriorated rubber parts, dirty/bad limit switches, physical damage.
2. Electrical Adjustments - coarse tracking, fine tracking, focus, laser power. However, some CD players no longer have some of these adjustments.
3. Electrical Component Failure. These are rare except for power surge (storm and lightning strike) related damage which if you are lucky will only blow out components in the power supply.

You can often repair a CD player which is faulty due to (1) or (2) except for laser power which I would not attempt except as a last resort without a service manual and/or proper instrumentation if needed - improper adjustment can ruin the laser. If discs are recognized at all or even if the unit only focuses correctly, then laser power is probably OK. While the laser diodes can and do fail, don't assume that every CD player problem is laser related.

In fact, only a small percentage (probably under 10%) are due to a failure of the laserdiode or its supporting circuitry. Mechanical problems such as dirt and lubrication are most common followed by the need for electrical (servo) adjustments.

Category (3) failures in the power supply can also be repaired fairly easily. Most other electrical failures would be difficult to locate without the service manual, test equipment, and a detailed understanding and familiarity with audio CD technology. However, you might get lucky.

#### Repair or replace?:

While CD players with new convenience features are constantly introduced, the basic function of playing a CD has not changed significantly in 15 years.

None of the much hyped 'advancements' such as digital filters, oversampling, one bit D/As and such are likely to make any difference in the listening pleasure of most mortals. Most people who care, do so only because they are more concerned with the technology than the musical experience. Most of these so called advances were done at least in part to reduce costs - not

necessarily to improve performance.

Therefore, unless you really do need a 250 disc CD changer with a remote control that has more buttons than a B777 cockpit and 2000 track programmability, a 10 year old CD player will sound just as good and repair may not be a bad idea. Many older CD players are built more solidly than those of today. Even some new high-end CD players may be built around a mostly plastic optical deck and flimsy chassis.

If you need to send or take the CD player or CDROM drive to a service centre, the repair could easily exceed the cost of a new unit. Service centres may charge up to \$50 or more for providing an initial estimate of repair costs but this will usually be credited toward the total cost of the repair (of course, they may just jack this up to compensate for their bench time).

If you can do the repairs yourself, the equation changes dramatically as your parts costs will be 1/2 to 1/4 of what a professional will charge and of course your time is free. The educational aspects may also be appealing. You will learn a lot in the process. Thus, it may make sense to repair that bedraggled old boombox after all.

## \*\*\*\*\* CD DIGITAL AUDIO TECHNOLOGY \*\*\*\*\*

### General Introduction to CD Technology:

Information on a compact disc is encoded in minute 'pits' just under the label side of the CD. The CD itself is stamped in much the same way as an old style LP but under much more stringent conditions - similar to the conditions maintained in the clean room of a semiconductor wafer fab. The CD pressing is then aluminum coated in a vacuum chamber and the label side is spin-coated with a protective plastic resin and printed with the label.

CD-Rs - recordable CDs use a slightly different construction. CD-R blanks are prestamped with a spiral guide groove and then coated with an ablatable layer followed by a gold film, resin, and label. The ablatable layer appears greenish. Recording blows holes in the ablatable layer which permits the laser beam to reflect off of the gold underneath.

The newest variation - DVDs or Digital Versatile Disks (or Digital Video Disks depending on who you listen to) - implement a number of incremental but very significant improvements in technology which in total add up to a spectacular increase in information density - almost 10:1 for the same size disc. These include higher frequency laser (670 or shorter visible wavelength), closer track spacing, better encoding, and a double sided disc. According to early reports on the final specifications, DVDs will be able to store 8 times the audio of current CDs at a higher sampling rate and bit resolution, 2 hours of MPEG encoded high quality movies, and all kinds of other information. Raw data capacity is somewhere between 5 and 10 GBytes.

The remainder of this document limits discussion to the standard CD format. However, many of the basic principles apply to these newer formats as well.

### CD information storage and playback:

The actual information to be recorded undergoes a rather remarkable transformation from raw

audio (or digital data) before it becomes microscopic pits. For audio, this process starts with prefiltering to remove frequencies above 20 kHz and analog-to-digital conversion at a sampling rate of 44.1 K samples per second for both stereo channels (88.2 K/s total). Note that in most cases of commercial or professional CDs, the original music has been recorded on multitrack digital tape at 48 K sample/second. All mixing and mastering operations are done at this sampling rate. The final step is conversion through resampling (sample rate conversion including sophisticated interpolation) to 44.1 Ks/second.

This is followed by sophisticated coding of the resulting 16 bit twos complement samples (interleaved between L and R channels) for the purpose of error detection and correction. Finally, the data is converted to a form suitable for the recording medium by 8-14 modulation and then written on a master disk using a precision laser cutting lathe (or now with CD-R, a modest priced CD recorder).

Like a phonograph record, the information is recorded in a continuous spiral. However, with a CD, this track (groove or row of pits - not to be confused with the selections on a music CD) starts near the center of the CD and spirals (counterclockwise when viewed from the label side) toward the outer edge. The readout is through the 1.2 mm polycarbonate disc substrate to the aluminized information layer just beneath the label. The total length of the spiral track for a 74 minute disc is over 5,000 meters or 3 miles in over 20,000 revolutions of the disc!

A series of electroplating, stripping, and reproduction steps then produce multiple 'stampers' which are actually used to press the discs.

The digital encoding for error detection and correction is called the Cross Interleave Reed Soloman Code or CIRC. To describe this as simply as possible, the CIRC code consists of two parts: interleaving of data so that a dropout or damage will be spread over enough physical area (hopefully) to be reconstructed and a CRC like error correcting code. Taken together, these two techniques are capable of some remarkable error correction. The assumption here is that most errors will occur in bursts as a result of dust specs, scratches, imperfections such as pinholes in the aluminum coating, etc. For example, the codes are powerful enough to totally recover a burst error of greater than 4,000 consecutive bits - about 2.5 mm on the disc. With full error correction implemented (this is not always the case with every CD player), it is possible to put a piece of 2 mm tape radially on the disc or drill a 2 mm hole in the disc and have no audio degradation. Some test CDs have just this type of defect introduced deliberately.

Two approaches are taken with uncorrectable errors: interpolation and muting. If good samples surround bad ones, then linear or higher order interpolation may be used to reconstruct them. If too much data has been lost, the audio is smoothly muted for a fraction of a second. Depending on where these errors occur in relation to the musical context, even these drastic measures may be undetectable to the human ear.

Note that the error correction for CDROM formats is even more involved than for CD audio as any bit error is unacceptable. This is one of many reasons why it is generally impossible to convert an audio CD player into a CDROM drive. However, since nearly all CDROM drives are capable of playing music CDs, much can be determined about the nature of a problem by first testing a CDROM drive with a music CD.

### CD (disc) construction:

The information layer as mentioned above utilizes 'pits' as the storage mechanism. Pits are depressions less than .2 um in depth (1/4 wavelength of the 780 nm laser light taking into consideration the actual wavelength inside the polycarbonate plastic). Thus, the reflected beam is 180 degrees out of phase with incident beam and cancels making for high contrast edges and good signal to noise ratio. Everything that is not a pit is 'land'. Pits are about .5 um wide and come in increments of .278 um as the basic length of a bit on the information layer of the disc.

Each byte of the processed information is converted into a 14 bit run length limited code taken from a codebook (lookup table) such that there are no fewer than 2 or more than 10 consecutive 0s between 1s. By then making the 1s transitions from pit to land or land to pit, the minimum length of any feature on the disc is no less than 3\*x and no more than 11\*x where x is .278 um. This is called Eight-to-Fourteen Modulation - EFM. Thus the length of a pit ranges from .833 to 3.054 um.

Each 14 bit code word has 3 additional sync and low frequency suppression bits added for a total of 17 bits representing each 8 bit byte. Since a single bit is .278 um, a byte is then represented in a linear space of 4.72 um. EFM in conjunction with the sync bits assure that the average signal has no DC component and that there are enough edges to reliably reconstruct the clock for data readout. These words are combined into 588 bit frames. Each frame contains 24 bytes of audio data (6 samples of L+R at 16 bits) and 8 bits of information used to encode (across multiple frames) information like the time, track, index, etc:

Sync	(24 + 3).
Control and display	(14 + 3).
Data	(12 * 2 * (14 + 3)).
Error correction	( 4 * 2 * (14 + 3)).
	-----
	588 total bits/frame

A block, which is made up of 98 consecutive frames, is the smallest unit which may be addressed on an audio CD and corresponds to a time of 1/75 of a second. Two bits in the information byte are currently defined. These are called P and Q. P serves a kind of global sync function indicating start and end of selections, time in between selections, and so forth. Q bits accumulated into one word made of a portion of the 98 possible bits encodes the time, track and index number, as well as many other possible functions depending where on the disc it is located, what kind of disc this is, and so forth.

Information on a CD is recorded at a Constant Linear Velocity - CLV. This is both good and bad. For CD audio - 1X speed - this CLV is about 1.2 meters per second. CLV permits packing the maximum possible information on a disc since it is recorded at the highest density regardless of location. However, for high speed access, particularly for CDROM drives, it means there is a need to rapidly change the speed of rotation of the disc when seeking between inner and outer tracks. Of course, there is no inherent reason why for CDROMs, the speed could not be kept constant meaning that data transfer rate would be higher for the outer tracks than the inner

ones, but this is, as far as I know, not implemented.

Note that unlike a turntable, the instantaneous speed of the spindle is not what determines the pitch of the audio signal. There is extensive buffering in RAM inside the player used both as a FIFO to smooth out data read off of the disc to ease the burden on the spindle servo as well as to provide temporary storage for intermediate results during decoding and error correction. Pitch (in the music sense) is determined by the data readout clock - a crystal oscillator usually which controls the D/A and LSI chipset timing. The only way to adjust pitch is to vary this clock. Some high-end players include a pitch adjustment. The precision of the playback of the any CD player is determined by a high quality quartz oscillator so that wow and flutter - key measures of the quality of phonograph turntables - are so small as to be undetectable. Ultimately, the sampling frequency of 44.1 K samples per second determines the audio output. For this, the average bit rate from the disc is 4.321 M bits per second.

Tracks are spaced 1.6 micrometers apart - a track pitch of 1.6  $\mu\text{m}$ . Thus a 12 cm disc has over 20,000 tracks for its 74 minutes of music. Of course, unlike a hard disk and like a phonograph record, it is really one spiral track over 3 miles long! However, as noted above, the starting point is near the center of the disc. The width of the pits on a track is actually about .5  $\mu\text{m}$ . The focused laser beam is less than 2  $\mu\text{m}$  at the pits. Compare this to an LP: A long long playing LP might have a bit over 72 minutes of music on two sides or 36 minutes per side. (Most do not achieve anywhere near this much music since the groove spacing needs to vary depending on how much bass content the music has and wide grooves occupy more space.) At 33-1/3 rpm, this is just over 1,200 grooves in about 4 inches compared to 20,000 tracks on a CD in a space of just over 1.25 inches! The readout styles for an LP has a tip radius of perhaps 2 to 3 mils (50 to 75  $\mu\text{m}$ ).

And you thought driving on a narrow winding country road was tough!:

-----

To put the required CD player servo system performance into perspective, here is an analogy:

At a constant linear velocity of about 1.2 meters per second, the required tracking precision is astounding: Proper tracking of a CD is equivalent to driving down a 10 foot wide highway (assuming an acceptable tracking error of less than +/- .35  $\mu\text{m}$ ) more than 3,200 miles for one second of play or over 14,400,000 miles for the entire disc without accidentally crossing lanes! Actually, it is worse than this: focus must be maintained all this time to better than 1  $\mu\text{m}$  as well (say, +/- .5  $\mu\text{m}$ ). So, it is more like piloting a aircraft down a 10 foot wide flight path at an altitude of about 12 miles (4 mm typical focal length objective lens) with an altitude error of less than +/- 7 feet! All this while the target track below you is moving both horizontally (CD and spindle runout of .35 mm) 1 mile and vertically (disc warp and spindle wobble of up to 1 mm) 3 miles per revolution! In addition, you are trying to ignore various types of garbage (smudges, fingerprints, fibers, dust, etc.) below you which on this scale have mountain sized dimensions. Sorry for the mixed units. My apologies to the rest of the world where the proper units are used for everything).

The required precision is unbelievable but true using mass produced technology that dates to the late 1970s. And, consider that a properly functioning CD player is remarkably immune to small bumps and vibration - more so than an old style turntable. All based on the reflection of a fraction of a mW of invisible laser light!

Of course, this is just another day in the entertainment center for the CD player's servo systems. Better hope that our technological skills are never lost - a phonograph record can be played using the thorn from a rosebush using a potter's wheel for a turntable. Just a bit more technology is needed to read and interpret the contents of a CD!

CD optical pickup operating principles:  
-----

The purpose of the optical pickup in a CD player, CDRom drive, or optical disk drive, is to recover digital data from the encoded pits at the information layer of the optical medium. For CD players, the resulting datastream is converted into high fidelity sound. For CDRoms or other optical storage devices, it may be interpreted as program code, text, audio or video multimedia, color photographs, or other types of digital data.

The following description assumes a 3 beam optical pickup - the most common type. (This is slightly simplified with some minor omissions for ease of understanding.) Most of the basic principles are similar for single beam CD pickups and other digital optical drives.

It is often stated that the laser beam in a CD player is like the stylus of a phonograph turntable. While this is a true statement, the actual magnitude of this achievement is usually overlooked. Consider that the phonograph stylus is electromechanical. Stylus positioning - analogous to tracking and focus in an optical pickup - is based on the stylus riding in the record's grooves controlled by the suspension of the pickup cartridge and tone arm. The analog audio is sensed most often by electromagnetic induction produced by the stylus's minute movements wiggling a magnet within a pair of sense coils.

The optical pickup must perform all of these functions without any mechanical assistance from the CD. It is guided only by a fraction of a mW of laser light and a few milligrams of silicon based electronic circuitry. Furthermore, the precision involved is easily more than 2 orders of magnitude finer compared to a phonograph. Sophisticated servo systems maintain focus and tracking to within a fraction of a micrometer of optimal. ( 1 um is equal to 1/25,400 of an inch). Data is read out by detecting the difference in depth of pits and lands of 1/4 wavelength of laser light (about .15 um in the CD)!

The laser beam is generated by a solid state laser diode emitting at 780 nm (near IR). Optical power from the laser diode is no more than a couple of mW and exits in a wedge shaped beam with a typical divergence of 10x30 degrees.

A collimating lens converts this into a parallel beam which then passes through a diffraction grating which splits the beam into a main beam and two side beams. (The higher order beams are not used). Note that the diffraction grating is used to generate multiple beams, not for its more common function of splitting up light into its constituent colors. The side beams are used for tracking and straddle the track which is being read. (The tracking servo maintains this centering by keeping the amplitude of the two return beams equalized.) Next, the laser beam passes through a cylindrical-convex lens which is used in conjunction with the focus servo. (As a result of this lens, the shape of the return beam changes as focal distance is adjusted and this is sensed to maintain correct focus to within a fraction of a um.) The laser beam then passes through a beam splitter prism which redirects the return beam to the photodiode array. A turning mirror or prism then reflects the laser light up to the objective lens and focus/tracking actuators.

The objective lens is similar in many ways to a high quality microscope objective lens. It is mounted on a platform which provides for movement in two directions. The actuators operate similarly to the voice coils in loudspeakers. Fixed permanent magnets provide the magnetic fields which the coils act upon. The focus actuator moves the lens up and down. The tracking actuator moves the coil in and out with respect to the disc center.

The collimated laser beam (including the 2 side beams) passes through the objective lens and is focused to diffraction limited spots on the information - pits - layer of the disc.

The reflected beam retraces the original path up until the beam splitter at which point it is diverted to the photodiode array. At the photodiode array, the resulting image of the disc's information layer is used for servo control of focus and tracking and for data recovery. In essence, the pickup is an electronically steered and stabilized microscope which is extracting information from tracks 1/20 the width of a human red blood cell while flying along at a linear velocity of 1.2 meters/second!

See the sections: "Parts of a CD Player or CDRom Drive" and "Startup Problems" for more information on the components and operation of the optical pickup.

[For more information on CD technology:](#)

The books listed in the section: "Suggested references" include additional information on the theory and implementation of digital audio, laserdisc, and optical drive technology.

For an on line introduction to CD and optical disc technology, point your web browser to the Magnavox reference page at the following URL:

<http://www.magnavox.com/electreference/electreference.html>

There you will find links to a number of articles on the basic principles of operation of CD players, laserdisc and optical drives, TVs, VCRs, cassette decks, loudspeakers, amplifiers, satellite receivers, and other consumer A/V equipment.



## CD PLAYER PLACEMENT, PREVENTIVE MAINTENANCE, AND CD CARE

### General CD player placement considerations:

Proper care of a CD player does not require much. Following the recommendations below will assure peak performance and long life, and minimize repairs.

\* Locate the CD player in a cool location. While the CD player is not a significant heat producer, keeping it cool will reduce wear and tear on the internal components and assure a long trouble free life.

\* Don't locate CD players in dusty locations or areas of high (tobacco) smoke or cooking grease vapors. I cannot force you to quit smoking, but it is amazing how much disgusting difficult to remove brown grime is deposited on sensitive electronic equipment in short order from this habit.

\* Make sure all audio connections are tight and secure to minimize intermittent or noisy sound.

\* Finally, store CDs away from heat. The polycarbonate plastic used to mold CDs is quite sturdy but high temperatures will eventually take their toll. Return them to their jewel cases or other protective container when not being played.

### Preventive maintenance:

You no doubt have heard that a CD should be cleaned and checked periodically. "Purchase our extended warranty" says the salesperson "because CD players are very delicate and require periodic alignment". For the most part, this is nonsense. CD players, despite the astonishing precision of the optical pickup are remarkably robust. Optical alignment is almost never needed for a component CD player and is rarely required even for portable or automotive units.

An occasional internal inspection and cleaning is not a bad idea but not nearly as important as for a VCR. Realistically, you are not going to do any PM anyway. So, just be aware of the types of symptoms that would be indications of the need for cleaning or other preventive or corrective maintenance - erratic loading, need to convince the CD player to cooperate and play a disc, audio noise, skipping, sticking, taking longer than usual to recognize a disc or complete a search.

Of course, acute symptoms like refusal to play or open the door is a sign of the need for emergency treatment. This still may mean that a thorough cleaning is all that is needed.

I generally don't consider CD lens cleaning discs to be of much value for preventive maintenance since they may just move the crud around. However, for pure non-greasy dust (no tobacco smoke and no cooking grease), they probably do not hurt and may do a good enough job to put off a proper cleaning for a while longer.

If you follow the instructions in the section: "General inspection, cleaning, and Lubrication", there is minimal risk to the CD player. However, don't go overboard. If any belts are in good condition (by appearance and stretch test), just clean them or leave them alone. Except for the Sony drawer loading mechanism, belts are rarely as much of a problem as in VCRs.

#### CD protection and handling:

Although CDs are considerably more tolerant of abuse than LPs, some precautions are still needed to assure long life. Also, despite the fact that only one side is played, serious damage to either side can cause problems during play or render the CD totally useless.

It is important that the label side be protected from major scratches which could penetrate to the information layer. Even with the sophisticated error correction used on the CD, damage to this layer, especially if it runs parallel to the tracks, can make the CD unusable. The CD is read by focusing a laser beam through the bottom 1.2 mm of polycarbonate. As a result of the design of the optical system used in the pickup, at the bottom surface, the beam diameter is about 1 mm and thus small scratches appear out of focus and in many cases are ignored and do not cause problems. At the information layer with the pits, the beam diameter has been reduced to under 2  $\mu\text{m}$ . Still, scratches running parallel to the tracks are more problematic and can cause the optical pickup to get stuck repeating a track, jumping forward or back a few seconds, or creating noise or other problems on readout. In severe cases, the CD may be unusable especially if the damage is in the directory area.

This is why the recommended procedure for cleaning a CD is to use soap and water (no harsh solvents which may damage the polycarbonate or resin overcoat) and clean in a radial direction (center to edge, NOT in the direction of the tracks as you would with an LP. While on the subject of CD care, CDs should always be returned to their original container for storage and not left out on the counter where they may be scratched. However, if there is a need to put one down for a moment, the label side is to be preferred since scratches have no effect on performance so long as they do not penetrate to the storage layer below.

#### CD cleaning:

Use a soft cloth, tissue, or paper towel moistened with water and mild detergent if needed. Wipe from center to edge - NOT in a circular motion as recommended for an LP. NEVER use any strong solvents. Even stubborn spots will eventually yield to your persistence. Washing under running water is fine as well.

Gently dry with a lint free cloth. Do not rub or use a dry cloth to clean as any dirt particles will result in scratches. Polycarbonate is tough but don't expect it to survive everything. Very fine scratches are not usually a problem, but why press your luck?

#### Rental or library CD considerations:

Unlike old or worn video tapes, it is unlikely that a 'bad' CD could damage your player. If the borrowed CD is dirty, clean it as described in the section: "CD cleaning". If it is badly scratched, the worst that will happen is that it will sound bad - skipping and audible noise. No damage to your player will result. However, if the CD is cracked or broken (this is really difficult to do but I have gotten cracked CDs from public libraries), don't even attempt to load it - a broken edge could catch on the lens and ruin the optical pickup entirely.

#### Repairing a scratched CD:

So your five year old decided that your favorite CD would make nice frisbee - didn't really know much about aerodynamics, did he?

Now it sounds like a poor excuse for a 78 rpm record. What to do?

There seem to be about as many ways of fixing scratches on CDs as producing them in the first place. However, they fall into 3 classes of techniques:

1. Mild abrasives: plastic or furniture polish, Brasso metal polish, toothpaste. These will totally remove minor scratches.
2. Fillers: turtle wax, car wax, furniture wax. Apply over the whole disc and buff out with a lint free cloth. Filling larger scratches should be fairly effective but the disc will be more prone to damage in the future due to the soft wax.
3. Blowtorch. At least one person who claims to have worked for several years in a used CD store swears by this technique. He uses a pencil type pocket butane torch and with great dexterity fuses the surface layer (polycarbonate) of the disc so that scratches and unsightly blemishes - well - melt away.

As with cleaning a CD, when applying or rubbing any of these materials, wipe from the center to the outside edge. A CD player can generally track across scratches that are perpendicular to its path reasonable well, but not those that run the parallel to the tracks.

A mild abrasive will actually remove the scratch entirely if it is minor enough. This is probably more effective where the surface has been scuffed or abraded rather than deeply scratched.

Wax-like materials will fill in the space where the scratch is if the abrasive was not successful. Even deep scratches may succumb to this approach.

A combination of (1) and (2) may be most effective.

Exorbitantly priced versions of these materials are available specifically marketed for repair of CDs. However, the common abrasives and waxes should work about as well.

I cannot comment on the use of the blowtorch or how many years of practice is required to get you CD repair license with this technique.

CD enhancers: -----

The process of reading a CD is digital. I have seen and heard advertisements for sonic rings or special magic markers to improve the quality of the digital audio reproduction. This is total bunk. Don't waste your money. These products do nothing beyond depleting your pocketbook - and enhancing those of the vendors.

\*\*\*\*\* **CD PLAYER AND CDROM DRIVE TROUBLESHOOTING GUIDE** \*\*\*\*\*

SAFETY: -----

While there are far fewer potential dangers involved in servicing a CD player compared to a TV, monitor, or microwave oven, some minimal precautions are still required when working with the cover removed:

\* Electrical: There may be a few exposed electrically live parts from the power line, usually around the power cord entrance, power transformer, and on/off switch. If there are, tape them over or cover them somehow so you need not be concerned with a low tech shock! Unless you are troubleshooting a primary side power supply problem, there will be no need to go near the AC line.

\* Laser: The laser in a CD player is infra red, IR - 780 nm - border of visible range but for all intents and purposes invisible. However, it is very low power (under 1mW) and due to the optics, extremely unlikely that you could be in any danger. Nonetheless, don't go out of your way to look closely into the lens while the unit is on! (Note: there is usually a very low (in appearance) intensity emission from the laser which appears deep red. It will be visible as just a spot the size of the period at the end of this sentence when the lens is viewed from an oblique angle. This may be a spurious emission in the red part of the spectrum or just your eye's response to the near IR energy of the main beam. In either case, do not be misled into thinking that the laser is weak as a result of noticing this. The main beam is up to 10,000 times more intense! Take care. However, the red dot is an excellent indication that the laser is being powered and probably functional, though it is no guarantee of the later. You really need a laser power meter or at least an IR detector to confirm the existence of a laser beam.

Troubleshooting tips: -----

Many problems have simple solutions. Don't immediately assume that your problem is some combination of esoteric complex convoluted failures. For a CD player, it may just be a bad belt or dirty lens. Try to remember that the problems with the most catastrophic impact on operation

(a CD player that will not play past track 6) usually have the simplest solutions (the gears that move the optical pickup need lubrication). The kinds of problems that we would like to avoid at all costs are the ones that are intermittent or difficult to reproduce: the occasional audio noise or skipping or a CD player that refuses to play classical CDs (depending on your tastes!) of music composed between the years 1840 and 1910.

When attempting to diagnose problems with a CDROM drive, start by trying to get it to play an audio CD. Data readback is more critical since the error correction needs to be perfect. However, with audio playback functional, all of the optical pickup and most of the servo systems and front-end electronics must be working. A CDROM drive which cannot even play a music CD will have no chance of loading Windows 95.

If you get stuck, sleep on it. Sometimes, just letting the problem bounce around in your head will lead to a different more successful approach or solution. Don't work when you are really tired - it is both dangerous and mostly non-productive (or possibly destructive).

Whenever working on precision equipment, make copious notes and diagrams. You will be eternally grateful when the time comes to reassemble the unit. Most connectors are keyed against incorrect insertion or interchange of cables, but not always. Apparently identical screws may be of differing lengths or have slightly different thread types. Little parts may fit in more than one place or orientation. Etc. Etc.

Pill bottles, film canisters, and plastic ice cube trays come in handy for sorting and storing screws and other small parts after disassembly.

Select a work area which is well lighted and where dropped parts can be located - not on a deep pile shag rug. Something like a large plastic tray with a slight lip may come in handy as it prevents small parts from rolling off of the work table. The best location will also be relatively dust free and allow you to suspend your troubleshooting to eat or sleep or think without having to pile everything into a cardboard box for storage.

Another consideration is ESD - Electro-Static Discharge. The electronic components in CD players, CDROM drives, and similar devices, are vulnerable to ESD. There is no need to go overboard but taking reasonable precautions like not wearing clothing made of wool that tends to generate static. When working on component CD and laserdisc players, get into the habit of touching a ground like the metal chassis before touching any circuit components. The use of an antistatic wrist strap would be further insurance.

A basic set of precision hand tools will be all you need to disassemble a CD player and perform most adjustments. However, these do not need to be expensive. Needed tools include a selection of Philips and straight blade screwdrivers, needlenose pliers, wire cutters, tweezers, and dental picks. A jeweler's screwdriver set is a must particularly if you are working on a portable CD player or CDROM drive. For adjustments, a miniature (1/16" blade) screwdriver with a non-metallic tip

is desirable both to prevent the presence of metal from altering the electrical properties of the circuit and to minimize the possibility of shorting something from accidental contact with the circuitry.

You should not need any CD specific tools except in the unlikely event you get into optical alignment in which case the service manual will detail what tools and special rigs are needed. A low power fine tip soldering iron and fine rosin core solder will be needed if you should need to disconnect any soldered wires (on purpose or by accident) or replace soldered components.

For thermal or warmup problems, a can of 'cold spray' or 'circuit chiller' (they are the same) and a heat gun or blow dryer come in handy to identify components whose characteristics may be drifting with temperature. Using the extension tube of the spray can or making a cardboard nozzle for the heat gun can provide very precise control of which components you are affecting.

For info on useful chemicals, adhesives, and lubricants, see "Repair Briefs, an Introduction" as well as other documents available at this site.

Test equipment: -----

Don't start with the electronic test equipment, start with some analytical thinking. Many problems associated with consumer electronic equipment do not require a schematic (though one may be useful). The majority of problems with CD are mechanical and can be dealt with using nothing more than a good set of precision hand tools; some alcohol, degreaser, contact cleaner, light oil and grease; and your powers of observation (and a little experience). Your built in senses and that stuff between your ears represents the most important test equipment you have.

A DMM or VOM is necessary for checking of power supply voltages and testing of sensors, LEDs, switches, and other small components. This does not need to be expensive but since you will be depending on its readings, reliability is important. Even a relatively inexpensive DMM from Radio Shack will be fine for most repair work.

For servo and other electronic problems, an oscilloscope will be useful. However, it does not need to be fancy. A 10 to 20 MHz dual trace scope with a set of 10X probes will be more than adequate for all but the most esoteric troubleshooting of CD players and CDROM drives.

To determine if the laser diode is working properly, a laser power meter is very useful. Such a device is expensive but is often essential to properly and safely adjust laser power on many CD players and CDROM drives. However, for many problems, simply knowing that an IR laser beam is being emitted is enough. For this, the simple device described in the section: "IR detector circuit" is more than adequate. Alternatively, an inexpensive IR detector card or even some camcorders can perform the same function.

A stereo amplifier and loudspeakers is essential to allow your most important piece of audio test equipment to function effectively - your ears. A lot can be determined by listening to the audio

output to distinguish among dirt, lubrication, servo, control, and other mechanical or electronic problems. I would caution against the use of headphones as a sudden burst of noise could blow your eardrums and spoil your entire day.

For testing of optical pickups, some additional equipment will be needed. However, this will be detailed in the section: "Testing of Optical Pickup Assemblies".

Test CDs: -----

An inexpensive test CD is nice to have just to be able to play known frequencies and volume levels. However, it is not essential - any half decent CD will work just fine for most tests. For many players, even an old CDROM disc will be adequate to diagnose startup problems. However, to fully exercise the limits of the player, a disc with a full 74 minutes of music will be needed - Beethoven's Ninth Symphony is a good choice (even if you are not into classical music) since it is usually very close (or sometimes slightly over) this length of time.

Keep those old demo CDs or even obsolete CDROM discs - they can be used for testing purposes. Where an optical deck has a servo problem, the disc will end up spinning out of control. Stopping this suddenly may result in the CD scraping itself against the drawer or base of the deck and getting scratched. Therefore, some 'garbage' discs are always handy for testing purposes.

To evaluate tracking and error correction performance, any CD can be turned into a test CD with multiple width strips of black tape, a felt tip marker, or even a hand drill! In fact, some professional test discs are made in exactly this manner.

Getting inside a CD player or CDROM drive: -----

**WARNING:** you will void the warranty, if any. You may make the problem worse - much worse. If the player partially worked, it may no longer even recognize the disc directory. You may accidentally damage parts that were perfectly fine. If you should decide to then have the unit professionally serviced, you may find that the shop simply refuses to touch it if they suspect your tampering. There is nothing worse than having to undo 'fixes' introduced by a well intentioned do-it-yourselfer where the state of the player is now a total unknown. At best you will be charged for this effort on a time and materials basis. It may be very costly. It may not be worth the expense.

A CD player still under warranty should probably be returned for service for any covered problems except those with the most obvious and easy solutions.

On the other hand, it is very likely that you will do a better job than a typical repair shop. You will probably have a better understanding of the basic theory and will be able to spend much more time on the problem. Hobbieist/handyman's time is cheap - as in free.

It is generally very easy to remove the top cover on most CD players. There are usually some very obvious screws on the sides and possibly back as well. These are nearly always Philips head type - use the proper screwdriver. Once all the screws are out, the top cover will lift up or slide back and then come off easily. If it still does not want to budge, recheck for screws you may have missed.

Once the top cover is removed, the optical deck and electronics board will usually be readily accessible.

With most designs, the entire optical deck can be lifted out after removing 3 or 4 screws. One screw may have a grounding contact under it. Replace this in exactly the same position. There may be fragile flexible cables. Be careful so as not to damage any. Usually, these cables plug in to connectors on the electronics board and permit the entire optical deck to be easily replaced if needed (not very common, however, despite what you may have heard).

In rare cases, removing the bottom cover will provide access to the solder side of the electronics board. However, with most CD players, the bottom is solid sheetmetal and the entire board would need to be unmounted.

For portables, the bottom plate usually comes off after removing several very tiny screws - use the proper size Philips blade jeweler's screwdriver.

For CDROM drives, both top and bottom covers may be removable depending on model.

Make notes of screw location and type and immediately store the screws away in a pill bottle, film canister, or ice cube tray.

When reassembling the equipment make sure to route cables and other wiring such that they will not get pinched or snagged and possibly broken, or have their insulation nicked or pierced, and that they will not get caught in moving parts. Replace any cable ties that were cut or removed during disassembly and add additional ones of your own if needed. Some electrical tape may sometimes come in handy to provide insulation insurance as well. (This applies mostly to portables and CDROM drives - component CD players are very wide open.

\*\*\*\*\* CD PLAYER AND CDROM DRIVE FUNDAMENTALS \*\*\*\*\*

Parts of a CD player or CDROM drive: -----

While CD players and CDROM drives started out and still have much in common, they are diverging. The optical pickups remain similar but the data processing and servo systems needed to support 8X speed CDROM technology are much more sophisticated than those needed for 1X speed CD audio. Therefore, should you peak inside your shiny new CDROM drive, you may see



parts that differ considerably from those in a Discman.

Power supply: -----

In component stereos units, there are normally linear supplies and thus very reliable but easy to fix as well. In portables, they are likely to be switching supplies, possibly sealed in a shielded can, and difficult to repair.

Usually, at least three voltages are needed: logic power (e.g. +5 Vcc) and a pair of voltages for the analog circuitry (e.g., +/- 15V). However, some designs use a variety of voltages for various portions of the analog (mainly) circuitry.

Electronics board: -----

This contains the microcomputer controller, servos, readback electronics, audio D/A(s) and filters. Most servo adjustment pots will be located here. In many cases they are clearly marked but not always. DO NOT turn anything unless you are sure of what you are doing - and then only after marking their original positions precisely.

The optical deck: -----

This subsystem includes all of the components to load and spin the disc, the optical pickup, and its positioning mechanism:

\* Loading drawer - Most portable and many lower cost CD players or CDROM drives lack this convenience. Most are motor driven. However, some must be pushed in or pulled out by hand.

Common problems: loose or oily belt causing drawer to not open or close, or to not complete its close cycle. There can be mechanical damage such as worn/fractured gears or broken parts. The drawer switch may be dirty causing the drawer to decide on its own to close. The motor may be shorted, have shorted or open windings, or have a dry or worn bearing.

\* Spindle/spindle table - When the disc is loaded, it rests on this platform which is machined to automatically center it and minimize runout and wobble.

Common Problems: Dirt on table surface, bent spindle, dry or worn bearings if spindle not part of motor but is belt driven, loose spindle.

\* Spindle motor - The motor that spins the disc. Most often the spindle platform is a press fit onto the spindle motor. Two types are common: The first is a miniature DC motor (using brushes) very similar to the common motors in toys and other battery operated devices. The second type is a brushless DC motor using Hall effect devices for commutation. In very rare cases, a belt is used to couple the motor to the spindle.

Common problems: partially shorted motor, shorted or open winding, dry/worn bearings.

\* Clamper - Usually a magnet on the opposite side of the disc from the spindle motor which prevents slippage between the disc and the spindle platform. The clamper is lifted off of the disc when the lid or drawer is opened. Alternatively, the spindle may be lowered to free the disc.

Common problems: doesn't engage fully permitting disc to slip on spindle due to mechanical problem in drawer closing mechanism.

\* Sled - The mechanism on which the optical pickup is mounted. The sled provide the means by which the optical pickup can be moved across the disc during normal play or to locate a specific track or piece of data. The sled is supported on guide rails and is moved by either a worm or ball gear, a rack and pinion gear, linear motor, or rotary positioner similar to what is in a modern hard disk drive - in increasing order of performance.

Common problems: dirt, gummed up or lack of lubrication, damaged gears.

\* Pickup motor - The entire pickup moves on the sled during normal play or for rapid access to musical selections or CDROM data. The motor is either a conventional miniature permanent magnet DC motor with belt or gear with worm, ball, or rack and pinion mechanism, or a direct drive linear motor or rotary positioner with no gears or belts.

Common problems: partially shorted motor, shorted or open winding, dry or worn bearings.

\* Optical pickup - This unit is the 'stylus' that reads the optical information encoded on the disc. It includes the laserdiode, associated optics, focus and tracking actuators, and photodiode array. The optical pickup is mounted on the sled and connects to the servo and readback electronics using flexible printed wiring cables.

Common problems: hairline cracks in conductors of flexible cable causing intermittent behavior.

Components of the optical pickup: -----

All the parts described below are in the optical pickup. As noted, the optical pickup is usually a self contained and replaceable subassembly. Despite its being a precision optomechanical device, optical pickups are remarkably robust in terms of susceptibility to mechanical damage.

\* Laserdiode - This is Infra Red (IR) emitting usually at 780 nm - near IR, just outside the visible range of 400-700 nm. The power output is no more than a few milliwatts though this gets reduced to .25-1.2 mW at the output of the objective lens. A photodiode inside the laserdiode case monitors optical power directly and is used in a feedback loop to maintain laser output at a constant and extremely stable value.

Common problems: bad laser diode or sensing photodiode resulting in reduction or loss of laser output.

\* Collimating lens - This converts the wedge shaped beam of the laser diode into nearly parallel rays.

\* Diffraction grating - In a 'Three Beam Pickup', this generates two additional lower power (first order) beams, one on each side of the main beam which are used for tracking feedback. It is absent in a 'Single Beam Pickup'.

\* Cylindrical lens - In conjunction with the collimating lens, this provides the mechanism for accurate dynamic focusing by changing the shape of the return beam based on focal distance.

\* Beam splitter - Passes the laser output to the objective lens and disc and directs the return beam to the photodiode array.

\* Turning mirror - Redirects the optical beams from the horizontal of the optical system to vertical to strike the disc.

Common problems: dirty mirror. Unfortunately, this may be difficult to access for cleaning.

The previous four items are the major components of the fixed optics. Outside of damage caused by a serious fall, there is little to go bad. Better hope so in any case - it is usually very difficult to access the fixed optics components and there is no easy way to realign them anyhow. Fortunately, except for the turning mirror, it is unlikely that they would ever need cleaning. Usually, even the turning mirror is fairly well protected and remains clean.

\* Objective lens - High quality focusing lens, very similar to a good microscope objective. N.A. of .45, focal length of 4 mm. Made of plastic with antireflection coating (the blue tinge in the center).

Common problems: dirty lens, dirt in lens mechanism, damage from improper cleaning or excessive mechanical shock.

\* Photodiode array - This is the sensor which is used to read back data and control beams.

Common problems: bad photodiode(s) resulting in improper or absence of focus and weak or missing RF signal.

\* Focus actuator - Since focus must be accurate to 1 micron - 1  $\mu\text{m}$ , a focus servo is used. The actuator is actually a coil of wire in a permanent magnetic field like the voice coil in a loudspeaker. The focus actuator can move the objective lens up and down - closer or farther from the disc based on focus information taken from the photodiode array.

Common problems: broken coil, damaged suspension (caused by mechanical shock or improper cleaning techniques).

\* Tracking actuator - Like focus, tracking must be accurate to 1 um or better. A similar voice coil actuator moves the objective lens from side to side based on tracking feedback information taken from the photodiode array.

Note: on pickups with rotary positioners, there may be no separate tracking coil as its function is subsumed by the positioner servo. The frequency response of the overall tracking servo system is high enough that the separate fine tracking actuator is not needed. Common problems: broken coil, damaged suspension (caused by mechanical shock or improper cleaning techniques).

Classification of CD player problems: -----

While there are a semi-infinite number of distinct things that can go wrong with a CD player, any set of symptoms can be classified as a hard failure or a soft failure:

1. Hard failure - door opening/closing problems, disc is not recognized, no sound, unit totally dead.
2. Soft failure - skips, continuous or repetitive audio noise, search or track seek problems, random behavior.

Both of these types of problems are common with CD players and CDRom drives. The causes in both cases are often very simple, easy to locate, and quick and inexpensive to repair.

Most common CD player problems: -----

The following two areas cover the most common types of problems you are likely to encounter. For any situation where operation is intermittent or audio output is noisy, skips, or gets stuck, or if some discs play and others have noise or are not even recognized consistently, consider these FIRST:

\* Dirty lens - especially if your house is particularly dusty, the player is located in a greasy location like a kitchen, or there are heavy smokers around. Cleaning the lens is relatively easy and may have a dramatic effect on player performance.

\* Mechanical problems - dirt, dried up lubrication, damaged parts. These may cause erratic problems or total failure. The first part of a CD may play but then get stuck at about the time location.

If your CD player has a 'transport lock' screw, check that it is in the 'operate' position.

General inspection, cleaning, and lubrication: -----

The following should be performed as general preventive maintenance or when any erratic behavior is detected. The lens, drawer mechanism, and sled drive should be checked, and cleaned and/or lubricated if necessary.

You will have to get under the clamp to access the lens (drawer loading models). Be gentle! NO lubrication is needed or should be used anywhere in the lens assembly!

At the same time, you will have access to the spindle.

\* Objective lens - Carefully clean the lens assembly. Be careful! The lens is suspended by a voice coil actuated positioner which is relatively delicate. A CD lens cleaning disc is nearly worthless except for the most minor dust as it will not completely remove grease, grime, and condensed tobacco smoke products (yet another reason not to smoke!) and make matters worse by just moving the crud around.

First, gently blow out any dust or dirt which may have collected inside the lens assembly. A photographic type of air bulb is fine but be extremely careful using any kind of compressed air source. Next, clean the lens itself. It is made of plastic, so don't use strong solvents. There are special cleaners, but alcohol (91% medicinal is ok, pure isopropyl is better. Avoid rubbing alcohol especially if it contains any additives) works ok for CD players and VCRs. There should be no problems as long as you dry everything off (gently!) reasonably quickly. **DO NOT LUBRICATE!** You wouldn't oil a loudspeaker, would you? When clean, the lens should be perfectly shiny with a blue tinge uniform over the central surface. If you can get to the turning mirror or prism under the lens without disturbing anything, clean that as well using the same procedure.

Do NOT use strong solvents or anything with abrasives - you will destroy the lens surface most likely rendering the entire expensive pickup worthless.

\* Spindle bearing - Check the spindle bearing (this is primarily likely to cause problems with repetitive noise). There should be no detectable side to side play. I.e., you should not be able to jiggle the platform that the CD sits on. If you find that the bearings are worn, it is possible to replace the motor (about \$10 from various mail order houses), though removing and replacing the disc platform may prove challenging as a result of the usual press fit mounting.

The focus servo can compensate for a vertical movement of the disc surface of 1 mm or so. A small bearing side play can easily cause larger vertical errors - especially near the end (outer edge) of the disc. Even if you are not experiencing problems due to bearing wear, keep your findings in mind for the future.

Sometimes there is a bearing runout adjustment screw on the bottom of the spindle if the spindle

is not driven by a standard permanent magnet motor. I have seen this in a Sony Discman which had a custom motor assembly. A small tweak to this may fix a marginal spindle problem.

To access the drawer mechanism and sled drive in component units, you will probably need to remove the optical deck from the chassis. It is usually mounted by 3 long screws (one of which may have a grounding doodad - don't lose it. In portables and CDROMs, the bottom panel of the unit will need to be removed. Try not to let any of the microscrews escape! A good set of jeweler's screwdrivers is a must for portables.

\* Drawer mechanism (if present) - Check for free movement. Test the belt for life - it should be firm, reasonably tight, and should return to its original length instantly if stretched by 25% or so. If the belt fails any of these criteria, it will need to be replaced eventually, though a thorough cleaning of the belt and pulleys with isopropyl alcohol (dry quickly to avoid damaging the rubber) or soap and water may give it a temporary reprieve.

Also, check the gears and motor for lubrication and damage and correct as necessary. Clean and lubricate (if necessary) with high quality light grease suitable for electronic mechanisms such as MolyLube or Silicone grease. A drop of light oil (electric motor oil, sewing machine oil) in the motor bearings may cure a noisy or dry bearing.

\* Sled drive - check the components which move the pickup including (depending on what kind of sled drive your unit has) belt, worm gear, other gears, slide bearings. These should all move freely (exception: if there is a lock to prevent accidental damage while the unit is being transported the pickup may not move freely or very far). Inspect for damage to any of these components which might impede free movement. Repair or replace an appropriate. Clean and lubricate (if necessary) with just a dab of high quality light grease suitable for electronic mechanisms such as MolyLube or Silicone grease). A drop of light oil (electric motor oil, sewing machine oil) in the motor bearings may cure a noisy or dry bearing. Also see the section: "Testing the sled for mechanical problems".

Try to play a disc again before proceeding further. I guess you have already done this.

Lubrication of CD players: -----

The short recommendation is: DO NOT add any oil or grease unless you are positively sure it is needed. Most moving parts are lubricated at the factory and do not need any further lubrication over their lifetime. Too much lubrication is worse than too little. It is easy to add a drop of oil but difficult and time consuming to restore an optical pickup that has taken a bath.

NEVER, ever, use WD40! WD40 is not a good lubricant despite the claims on the label. Legend has it that the WD stands for Water Displacer - which is one of the functions of WD40 when used to coat tools for rust prevention. WD40 is much too thin to do any good as a general lubricant and will quickly collect dirt and dry up.

A light machine oil like electric motor or sewing machine oil should be used for gear or wheel shafts. A plastic safe grease like silicone grease or Molylube is suitable for gears, cams, or mechanical (piano key) type mode selectors. Never use oil or grease on electrical contacts.

Unless the unit was not properly lubricated at the factory (which is quite possible), don't add any unless your inspection reveals the specific need. In a CD player or CDROM drive, there are a very limited number of failures specifically due to lubrication.

Note that in most cases, oil is for plain bearings (not ball or roller) and pivots while grease is used on sliding parts and gear teeth. If the old lubricant is gummed up, remove it and clean the affected parts thoroughly before adding new oil or grease.

In general, do not lubricate anything unless you know there is a need. Never 'shotgun' a problem by lubricating everything in sight! You might as well literally use a shotgun on the equipment!

\*\*\*\*\* GENERAL SYSTEM PROBLEMS \*\*\*\*\*

Unit is totally dead: -----

Check input power, power cord, fuse, power supply components. Locate the outputs of the power transformer and trace them to the rectifiers and associated filter capacitors and regulators. While the actual voltages will probably not be marked, most of the power in a CD player will be typically between +15 and -15 VDC. Sometimes, the voltage ratings of the filter capacitors and/or regulators will provide clues as to correct power supply outputs. Don't forget the obvious of the line cord, line fuse (if present), and power switch - or outlet. Most component CD players use linear power supplies so troubleshooting is straightforward. However, portables and CDROMs use DC-DC inverters to generate the several voltages required and these are more difficult to troubleshoot. If an incorrect power adapter was used, then major damage can result despite the various types of protective measures taken in the design.

I inherited a Sony Discman from a guy who thought he would save a few bucks and make an adapter cord to use it in his car. Not only was the 12-15 volts from the car battery too high but he got it backwards! Blew the DC-DC converter transistor in two despite the built in reverse voltage protection and fried the microcontroller. Needless to say, the player was a loss but the cigarette lighter fuse was happy as a clam!

Moral: those voltage, current, and polarity ratings marked on portable equipment are there for a reason. Voltage rating should not be exceeded, though using a slightly lower voltage adapter will probably cause no harm though performance may suffer. The current rating of the adapter should be at least equal to the printed rating. The polarity, of course, must be correct. If connected backwards with a current limited adapter, there may be no immediate damage depending on the design of the protective circuits. But don't take chances - double check that the polarities match - with a voltmeter if necessary - before you plug it in! Note that even some identically marked adapters put out widely different open circuit voltages. If the unloaded voltage reading is more than

25-30% higher than the marked value, I would be cautious about using the adapter without confirmation that it is acceptable for your player. Needless to say, if the player behaves in any strange or unexpected manner with a new adapter, if any part gets unusually warm, or if there is any unusual odor, unplug it immediately and attempt to identify the cause of the problem.

See the document: "Notes on the Repair of Audio Equipment and other Miscellaneous Stuff" for more info on troubleshooting of linear power supplies. See the document "Notes on the Diagnose and Repair of Small Switchmode Power Supplies" for more info on troubleshooting DC-DC convertors.

CD player is operational but there is no display: -----

Sometimes the display requires backlighting which uses miniature incandescent lamps. These burn out. Usually, alternatives to the high priced exact replacement bulbs can be located. Test the bulbs with an ohmmeter. Measure the voltage across the light bulb connections and then replace the bulb with one of about 25-50% higher voltage. These may not be quite as bright but should last forever.

If the light bulbs are not at fault or there are no light bulbs, then check for power to the display including bad connections or connectors that need to be reseated. There could also be a power supply (e.g., missing voltage for a vacuum fluorescent display) or driver problem.

CD player ignores you: -----

Symptoms are that the display comes up normal when power is turned on but all (or certain) commands are ignored.

This could mean several things:

- \* Front panel problem - one or more buttons are not responding. Reseat internal cables, clean or replace offending push button switches. If your CD player has a remote control, see if it operates correctly.

- \* Reset failure - the player has failed to reset properly and is not ready for user input. Check power supply voltages, reseal internal connectors.

- \* Controller and/or driver electronics for the affected functions are defective. Check power supply voltages, reseal internal connectors.

For all but the first one, a service manual will probably be needed to precede further if the problem is not with a bad power supply or bad connections.

Drawer does not open or close: -----

If the drawer doesn't open when the front panel button is pressed, listen for motor attempting to



open the drawer. If you hear it whirring but nothing happens, check for an oily/loose belt or other mechanical fault. The belt may be cleaned for temporary repair, replacement will be needed eventually. If there is no attempt, motor, control chip, or front panel pushbutton (try with the remote if you have one to eliminate this possibility) could be bad. Sony players seem to have a built in timer that triggers the belt to go bad after the warranty runs out. Also see the section on "Small Motors in CD Players".

Drawer operation is erratic: -----

You are about to remove your favorite CD but the player beats you to it, closes the drawer, and starts playing it over again. Or, the drawer reverses course halfway out. Or, the drawer motor continues to whir even after the door is fully open or closed and the front panel is then unresponsive.

This is usually due to dirty contacts on the door position sense switches. There are usually 3 sets of switch contacts associated with the drawer mechanism. If any of these get dirty, worn, or bent out of place, erratic operation can result:

\* Drawer closed sense switch - dirty contacts may result in the drawer motor continuing to whir after the door closes and the front panel may then be unresponsive. Eventually, the drawer may open on its own.

\* Drawer open sense switch - dirty contacts may result in the drawer motor continuing to whir after the door opens and the front panel may then be unresponsive. Eventually, the drawer may close on its own.

\* Drawer pushed sense switch - most CD players allow the user to start play by gently pushing on the drawer which depresses a set of switch contacts. If these are dirty, the result may be the drawer deciding to close on its own or reversing direction in the middle of opening or closing.

The solution to all these problems is usually to simply locate the offending switches and clean their contacts. These switches contacts are usually not protected from dust, dirt, and grime so that these types of problems are quite common.

Drawer does not close completely: -----

This is a symptom that may not be obvious. The drawer may appear to close but a loose or oily belt can prevent the mechanism from completing the close cycle. This can result in erratic behavior since the disc clamping action is often controlled by the movement - sometimes not recognizing disc, sometimes just opening the drawer, or more subtle things like tracking problems, etc. Clean the belt and see if there is any improvement. Belt replacement will be necessary eventually. Check for gummed up lubrication as well.

If it goes through the motions of closing and then stops short without any further sounds, a gear may have jumped a tooth or broken some. The result is either that the mechanism is now incorrectly timed or not able to complete the operation. Examine the mechanism closely for broken parts. Cycle it manually by turning the appropriate motor pulley or gear to see if the drawer gets hung up or is much more difficult to move at some point.

If it continues to make a whirring sound after the drawer stops, there might be some other kind of mechanical damage resulting in an obstruction or really gummed up lubrication not allowing the operation to complete.

Intermittent operation: -----

When a CD player appears to have a mood problem - playing fine sometimes or for only part of a disc or aborting at random times, there can be several possible causes including a dirty lens, dirty or worn interlock switch or bad connections to interlock switch (mainly portables and boomboxes), flex cable with hairline cracks in one or more conductors, other bad connections, marginal power supply, defective disc.

\* Dirty, scratched, or defective CD - confirm that the CD is not the problem. Clean the disc and/or try another one.

\* Dirty lens - a player that accepts some discs and not others or accepts discs sporadically may simply need its eyeglasses cleaned.

\* Mechanical - oily, flabby belts preventing full drawer closing or gummed up lubrication on the sled (may fail depending on ambient temperature. For example, if the music gets stuck at about the same time on every disc, then there may be gunk on the end of the sled track preventing the sled from moving any further. This is especially likely if you just purchased a disc with an unusually long playing time - it has nothing to do with the musical tastes of the CD player! (There was this Chinese restaurant where the Chinese cooking grease apparently collected on the unused end portion of the sled track and when they tried to play an extra long CD.....)

Note: some players will simply not play discs which exceed about 74 minutes - the legal limit for CD playing time. Some discs may be as long as 78 minutes or more which means that some aspects of the CD specifications were compromised.

\* Bad connections - there are often many little connectors used to get signals and power between the optical deck and main circuit board. These are usually cheaply made and prone to failure. Wiggling and reseating these may cure these problems. There may even be bad solder connections on the pins of connectors or board mounted switches. Slight flexing or just expansion and contraction may result in intermittent shutdown or other problems. These problems are more likely with portables and boomboxes which may get abused.

\* Cracks in ribbon cable - The moving and fixed parts of the optical pickup are often joined with a printed flexible cable. Constant flexing may cause one or more of the copper traces to crack. This may show up as an inability to get past a certain point on every disc - the player may shut down or start skipping at around 23 minutes into every CD.

\* Dirty switches - oily film or oxidation may be preventing any of the limit or interlock switches from making reliable contact. If this is the case, the player may stop at random times, fail to accept a disc, close the drawer without your permission, etc. Use contact cleaner and typing paper to clean the contacts. Disassembly may be required for enclosed switches.

\* Power supply or logic problems are also possible but rare. However, if you have a scope, check the power supply outputs for ripple - a filter capacitor may have dried up and lost most of its capacitance.

CD player or CDROM drive overheats: -----

A CD player which becomes noisy or a CDROM drive that fails to recognize discs or reliably read data after a few minutes may have a component that is heating up and changing value.

In general, there should not be much change in behavior from the instant power is applied until the next millennium. There is not much in a CD player or CDROM which runs hot and might change characteristics. However, components do sometimes fail in this manner. Problems of this type need to be diagnosed in much the same way as one would find overheating components in a TV or computer monitor.

You will need a can of cold spray ('circuit chiller') and an oscilloscope, if available. Even a hair dryer on the no-heat setting will work in a pinch.

You are going to have to try cooling various components to try to determine which one is bad. However, on a unit that dies completely and suddenly after it warms this will not be much fun since you will not have ample opportunity to detect changes in behavior. On a CD player that will play but with tracking problems and/or audio noise, you should be able to monitor the playback quality by simply listening for improvement when you have cooled the flakey part. For a CDROM drive, play an audio disc if possible since this will provide the feedback you need to locate the bad part without (hopefully) it constantly shutting down due to data errors or inability to reliably access the file system.

First, I would recommend running with the covers removed and see if that has an effect confirming a thermal problem. Next, use the cold spray on individual components like the LSI chips - quick burst, wait a few seconds for something to change. If you are using the hairdryer, make a funnel out of paper to direct the air flow. You will need to be more patient with this approach.

If you have a scope, it would be nice to look at the RF 'eye' pattern during this time and see if it

decreases in amplitude and/or quality over the course of an hour. If it does, you may have an overheating problem in the laserdiode or its power supply.

\*\*\*\*\* STARTUP PROBLEMS \*\*\*\*\*

What is a startup problem?: -----

Startup problems cover all situations where the player does not successfully read the disc directory. Nearly everything in the optical deck and much of the mainboard electronics needs to be functional to read the directory. Therefore, a single failure in any of a large number of places can prevent successful startup (and subsequent play).

\* On a single play unit, failure of the startup sequence may result in a display of no disc, disc, error; a full calander but no disc info; or it may just open the door and challenge you to provide it with a proper meal.

\* On a changer, failure of the startup sequence will likely result in a similar display but then the unit will move on to the next position in the carousel or cartridge. It will likely remember that it was unsuccessful at loading a disc for each position and eventually give up once all possible discs have been tried.

Possible causes for startup failure include: defective disc, dirty lens, defective laser or photodiode array, bad focus or tracking actuator or driver, dirty track, lack of or dried up lubrication, dirty or bad limit switches or sensors, defective spindle motor, faulty electronics or control logic, damaged parts, or faulty optical alignment or need for servo adjustments. On the one hand this is a large number of possibilities. The good news is that with such a large number of possibilities, there is a good chance the problem will be minor and inexpensive to fix.

Don't overlook the trivial: are you loading the disc correctly? Most CD players want the disc label-side up. However, some, like Pioneer magazine type changers want the label-side down. If you have just acquired the CD player, don't overlook this possibility.

Startup sequence: -----

There will be variations on the exact startup sequence of events depending on the type of player and its design. The result may be a blank display, display of the word 'disc' or 'error', flashing display, etc. In any case, you don't get your music. By understanding the following summary as it applies to your player, you should be able to determine what is going wrong.

What the CD player should do when a disc is inserted:

1. Drawer closes (or with portables, lid is closed manually) and CD is clamped to spindle.
2. Interlock (if present, always in portables) engages. In others, there may be an optical sensor

or the optical pickup may act as its own disc sensor.

3. Pickup resets to starting (index) location toward center of disc usually found with limit switch or optical sensor.

4. For the following, refer to the diagram below of the photodetector organization typical in units with a 'three beam pickup'. E and F will be absent in units with a 'single beam pickup', though there may be other segments. The four quadrant photodetector is present in all systems.

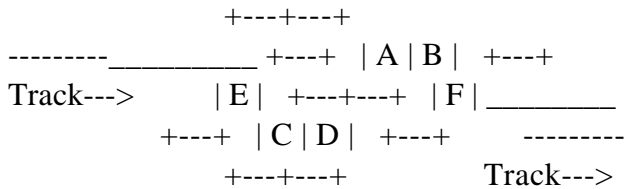

The main return beam is detected by the array, ABCD. The tracking beams return to E and F. E is offset slightly off track on one side and F on the other. Average signals from E and F will be equal when centered on track.

4a. Laser is turned on and focus search routine is started to position lens at correct vertical position. Once correct focus is achieved, focus servo is activated to maintain it. Focus, which must be accurate to 1 um, operates as follows: The optical path in the pickup includes a cylindrical lens which causes the laser beam spot to be circular when correctly focussed but elliptical otherwise with the major axis of the ellipse being offset 90 degrees depending on whether the lens is too close or too far (e.g., major axis of +45 degrees for too close and -45 degrees for too far).  $\text{Focus Error} = (A+D)-(B+C) = 0$  for correct focus since with the circular spot, the outputs of all four quadrants will be equal.

4b. Disc starts spinning up to 500 rpm and Constant Linear Velocity (CLV) servo is activated to maintain correct speed. CLV servo uses a PLL to lock to clock transitions derived from data read off of disc. Data is derived from  $A+B+C+D$ .

4c. Tracking servo is activated to maintain laser beam centered on track. With 'three beam pickup', 2 additional laser spots are projected onto the disc in front of and behind main beam. These are offset on each side of the track just enough so that  $\text{Tracking Error} = E-F = 0$  when centered. With a 'single beam pickup', similar information is derived using only the main beam since  $\text{Tracking Error} = (A+B)-(C+D) = 0$  for correct tracking.

5. Disc directory is read and displayed.

6. Unit shuts down awaiting command or goes into play mode depending on how it was activated.

The steps listed as (4a,b,c) may or may not be performed concurrently. If any of 1-5 fail, then the laser is turned off and the machine will display some kind of error no disc message (typically, it may display Error, Disc, or go blank) and return to idle mode, or in the case of a changer, load the next disc and try again.

Procedure for validating the startup sequence: -----

The following procedure is used when the disc is not recognized but the drawer closes completely.

First, double check the drawer closing/opening mechanism. Without exception, Sony CD players which have belts need them cleaned and eventually replaced. If the drawer does not close completely, then the disc may not be clamped properly or other erratic problems may occur.

Once you have verified that this is ok, you need to determine that the lens is clean. In general, the lens should look shiny with a blue tinge. Any scum or crud can degrade performance. You may have to remove part of the clamping mechanism to be able to see the lens. If it is not perfectly shiny, clean it using the procedures in the section: "General inspection, cleaning, and lubrication".

Assuming that this does not improve the situation, the next step is to verify that the pickup has reset itself to the inner (center) track of the disc. If necessary manually move the pickup away from the center by turning the appropriate pulley or gear, or in the case of a linear actuator or rotary positioner (no gears or belts), just push the pickup gently and observe the behavior when a disc is loaded. The pickup should move smoothly toward the center, usually tripping a limit switch and stopping. If there is no movement or movement is jerky or the pickup gets stuck at some point, then lubrication may be needed or the motor or drive circuitry may be faulty. Also, check for broken or damaged gear teeth, a slipping belt, and misaligned or damaged tracks. Measure the voltage on the motor that moves the pickup. If there is none or it is very low (under a volt or so), then there is a problem with the motor, its driver, or the system controller.

Determine if the machine attempts to focus. On portables, it is sufficient to defeat the door interlock to get the operations associated with reading of the disc directory to begin (you may need to press play - this is model dependent). In some component CD players, a disc actually has to be present to block an optical sensor. You should see the lens moving up and down (at least one of these directions will have smooth movement) once or twice about 2 mm. If a disc is in place, then the lens should quickly stop at the appropriate focus position. Admittedly, observing the lens may be difficult or impossible with the disc in place. Dentists are probably good at this!

If the focus action is identical whether a disc is in place or not - i.e., it keeps up the search pattern and then gives up - verify that the laser is being powered. In most cases, you should be able to see a tiny spot of red appearing light when the lens is viewed from an oblique angle during the focus search. From a safe distance of at least six inches and 45 degrees or more off to one side, you should be able to see this dim red light in a darkened room while the unit is attempting to focus. If you see this, you can assume that the laser is being powered though it is not a sure test for an

actual IR laser beam or proper optical power output. In most cases, however, the red light indicates that the laser is working. An IR detector would confirm at least that there is an IR emission. If there is no dot of red light, then either the laser diode is bad, it is not being powered, or you are not looking from the correct angle. You can purchase an inexpensive IR detector card from an electronics distributor or build one using a photodiode, a few resistors, a general purpose small signal transistor, and an LED running off a 9 V battery. See the schematic at the end of this document. This will also be useful for testing remote controls. If you have a modern camcorder (one with a CCD pickup, not a tube), it may be sensitive to IR as well but using one to test a CD laser would be pretty clunky to say the least (you would probably need to grow an extra arm or two).

Once focus is established (and sometimes concurrent with this operation), the spindle should begin to turn and quickly reach 500 rpm. The speed may be ramped up or controlled in some other search pattern since there is no speed feedback until the data coming off of the disc is available. A partially shorted motor will prevent the spindle from reaching 500 rpm even though the disc will spin. Check the voltage on the spindle motor when it starts the disc spinning. It should reach 2 volts or more. If less than this but not zero, a partially shorted motor or weak driver is likely. If zero at all times then there may be a bad driver or the machine may not realize that focus was established and is not issuing the spindle motor start command. The required speed of 500 rpm - just over 8 revolutions per second - can be estimated by using a disc with a dramatic label or putting a piece of tape on the side of the disc that is visible and watching it spin.

Note that a dirty lens can sometimes result in symptoms similar to a bad spindle motor so cleaning the lens should always be the first step when servicing a CD player. I almost learned this the hard way.

Once the disc reaches the correct speed, the speed control (Constant Linear Velocity, CLV) and tracking servos will be activated (or the tracking servo may actually have been active all along) and directory data will be read off of the disc. Either of these could be faulty and/or misadjusted making it impossible to access the disc directory.

During the time that the disc is spinning and the player is attempting to read the disc directory, listen for that 'gritty' sound that CD players make during normal operation. It is a byproduct of the focus and tracking servos constantly adjusting lens position - the rapid movements of the lens produce audible sound like a loudspeaker - and its presence is a good indication that (1) the laser is working and (2) focus is being maintained.

On certain CD players, for example many Pioneer models, there is a TEST mode which enables many of the individual functions such as focus and tracking that are normally automatic to be manually enabled. This is a very useful aid in diagnosis and in adjusting a machine from an unknown state as would be the case if someone else twiddled every internal adjustment they could find! See the section: "Pioneer PDM series test mode".

Disc spins in wrong direction or overspeeds and is never recognized:  
-----

The CD should always spin clockwise as viewed from the label side of the CD. This is usually the top but for some players you load the CD upside-down (e.g. Pioneer magazine type changers). If the CD should consistently start spinning counterclockwise and continue for more than a fraction of a revolution, or should the CD ever spin at a much faster rate than normal - as though it is about to take off, there may be a serious problem with the optical pickup, spindle servo, or control logic. However, behavior of this type could simply be the result of any of a number of minor faults which you can diagnose and repair including a dirty lens, the disc being loaded upside-down, or the internal adjustments being messed up due to someone violating rule #1 - never wildly tweak any internal adjustments!

First confirm that the disc is loaded correctly and that the lens is clean.

If this does not help, attempt to perform a servo system adjustment. If you have a service manual, by all means follow it! If not, see the section: "Servo adjustment without a service manual". If it is a Pioneer CD player or changer, see the section: "Pioneer PD-M400/500/600 etc. servo adjustment procedure" (this may also apply to other models with only minor changes).

\*\*\*\*\* TRACKING (PLAY AND SEEK) PROBLEMS \*\*\*\*\*

Description of these types of failures: -----

Proper readout of the digital audio or data on a CD depends on the proper functioning of the focus, and tracking servos and the system controller.

While playing, searching, or seeking, focus must be maintained continuously despite spindle runout, a moderately warped disc, and minor bumps or vibration.

When playing at normal speed (e.g., 1X for music), the fine tracking servo maintains the laser beam centered on the track (pits of the information layer) of the CD while the coarse tracking servo moves the entire optical pickup as needed to keep the tracking error within well defined limits. See the section: "Servo systems". Failures or marginal performance of any of these systems can result in audio noise, skipping, sticking, or failure of seek and search operations.

A dirty or badly scratched or warped disc, a dirty lens, as well as other electronic or mechanical problems can result in similar symptoms as well.

Thus, if you experience any of the problems discussed in the next few sections, first confirm that the disc is not dirty, scratched, smudged, warped, or otherwise defective - inspect and clean it if necessary and/or try a different one. If this does not help, then manually clean the lens.



The importance of doing these simple things first cannot be overemphasized as many apparently unrelated problems can be caused by a bad disc or dirty lens.

Then, check for obvious mechanical faults like gummed up lubrication or a worn spindle bearing. Only after these efforts do not solve your problem or at least identify the cause, should you consider adjusting any of the servo systems.

Short distance skipping: -----

This means jumping forward or backward by a fraction of a second. It may occur occasionally or may appear as though the pickup is bouncing across the disc. Common causes include dirty lens, dirty or damaged disc, need to adjust fine tracking offset/gain or tracking balance, weak laser.

First, inspect the disc for badly scratched or smudged areas and other defects or try another one. Clean the lens.

Playback gets stuck (rapid repeat): -----

This means repeating the same track or a small number of tracks (meaning disc rotations, in this case). The effect is somewhat like a 'broken record' with an LP but at a much faster rate - 3 to 8 repeats per second when repeating only a single track.

The most common underlying cause is a damaged or dirty disc. However, if the tracking (and sometimes focus as well) servos are not properly adjusted, the CD player may exhibit excessive sensitivity to disc problems.

If the focus or tracking gain is set too high or the offsets/balance are not centered, slight disc imperfections, scratches, or dirt may result in this set of symptoms.

Occasional long distance skipping or repeating: -----

Usually, several seconds of music will play without any trouble and then there will be a skip forward or backwards by a few seconds or longer. In the latter case, the net effect may be to constantly repeat a section of the CD. Make sure you do not have any repeat modes enabled!

Common causes include a dirty lens; dirt, foreign materials, or lack of lubrication in pickup drive; defective disc (surface defects, dirt, or fingerprints); mechanical damage causing mechanism to bind.

First, inspect the disc for badly scratched or smudged areas and other defects or try another one. Clean the lens.

A mechanical fault is quite likely. These symptoms generally indicate that the coarse tracking servo is unable to properly move the pickup easily as it should - it is getting stuck and then either jumping back once the error is too great or breaking free and moving forward in spurts.

Eliminate the possibility of mechanical problems - see the section: "Testing the sled for mechanical problems".

Player gets stuck at approximately same time on multiple discs:

-----

Common causes: gummed up lubrication on pickup tracks or worm gear, other mechanical problems like an obstruction or errant wire getting in the way. A flex cable with a hairline crack in one or more conductors might also cause this symptom.

Carefully inspect the tracks for dirt and gummed up lubrication. If the player has been in commercial service always playing the same CD or set of CDs and now you are attempting to one that is someone longer, this may happen.

Also, if you are attempting to play a CD which is longer than 74 minutes, the player may not be capable of accessing the last part of the CD. It might either abort or get stuck and keep repeating a fraction of a second or several seconds.

Search or seek operations take too long or fail to complete:

-----

This means that attempting to seek to a particular music track results in this never completing or going to the wrong place. Alternatively, even pressing the search forward or backward buttons may result in the failure to go where directed. The player may abort the disc and stop or (in the case of a changer) go on to the next one.

Common causes: dirty lens, bad disc, tracking or CLV PLL adjustments needed, mechanical problems with pickup movement, faulty sled motor drive IC, faulty control logic, bad flex cable.

If your CD player has a 'transport lock' screw, check that it is in the 'operate' position.

Inspect the disc for badly scratched or smudged areas and other defects or try another one. Clean the lens.

Eliminate the possibility of mechanical problems - see the section: "Testing the sled for mechanical problems".

Check for a printed flex cable that has hairline cracks in one or more traces. As the pickup moves past a certain location, a critical connection may open up resulting in this behavior. Such a cause

is more likely if the player aborts without warning during a seek or search.

If none of this uncovers the problem, there may be sled motor driver, logic, controller, or other electronic problems.

Search, seek, or play starts at proper place but then loses time or position:

-----

You may select music track 5, the player goes there quickly, starts to play but immediately jumps to another location forward or backwards or resets to the start of the disc. Or, if play is started at any location, instead of playing forward as would be expected, the numbers in the display count down.

Common causes include a stuck button, need to adjust coarse tracking offset or tracking balance, bad sled motor drive IC, faulty control logic, defective disc.

First, try a different CD to make sure it is not defective. Or, try different locations on the same CD as the CD would likely not be defective over its entire surface.

While a dirty lens is possible, it is not as likely as for many other tracking problems.

This may be a problem with coarse tracking offset or tracking balance. See the section: "Adjustment procedure for noise or skipping"

To eliminate the possibility of a stuck button, it may be possible to operate the player with the relevant part of the front panel control unplugged using the remote control (if it has one) or the 'press the drawer' method of starting play. If either of these results in the disc playing normally, then a stuck or dirty button is likely. This will most likely require the disassembly and cleaning or replacement of the affected push button switch.

It is possible that the sled motor driver IC or its logic is bad: when the tracking servo is closed, its output is highly unbalanced due to an internal failure. Unless you want to take a shot in the dark and replace the chip, further troubleshooting of this problem will likely require a service manual.

Repetitive noise at disc rotation rate (500-200 rpm depending on track):

-----

Common causes: dirty lens, bent spindle, excessive runout (wear) of spindle bearing, loose spindle, foreign material on disc table, warped disc, need to adjust focus or fine tracking offset/gain, weak laser.

First, inspect the disc for badly scratched or smudged areas and other defects or try another one. Clean the lens.

Check for a loose spindle (sometimes there is a set screw that needs to be tightened or some adhesive may have broken free. Make sure there is no dirty or other foreign matter on the spindle table that could cause the disc to seat improperly.

Observe the disc as it spins. Is the edge moving up and down by more than a total of about 1 mm? If so, the disc may be excessively warped, or possibly the spindle bearing is worn resulting in unacceptable runout, or (unlikely unless the player was thrown off a cliff) the spindle is bent. The focus and fine tracking servos may be incapable of correcting such a large wobble.

If the problem developed gradually and has been getting worse, than a worn spindle bearing is a distinct possibility. Adjustment of focus and fine tracking offset (or possibly gain but usually less critical) may help.

Alternatively, focus or fine tracking offset (or possibly gain but usually less critical) may simply have drifted a bit and adjustment is all that is needed.

A weak laser may also result in these symptoms but do not attempt to adjust laser power until other possibilities have been investigated fully.

Testing the sled for mechanical problems: -----

Binding or obstructions would be indicated by any long distance skipping, jumping, repeating, or failure to seek or search past some location (time) on multiple discs. Defective or erratic limit switches may result in jamming or overrun at start or end of disc or unreliable reset during startup.

Check for free movement of the optical pickup sled on its tracks or bearings. Manually rotate the appropriate motor or gear or in the case of a voice coil (linear or rotary) positioner, gently move the pickup back and forth throughout its range. There should be no sticky positions or places where movement is noticeably more difficult. If there are, inspect for mechanical problems like broken or damaged gear teeth, dirt or other material that should not be there, and gummed up lubrication. Damaged parts will need to be replaced (or repaired - sometimes a fine file, Xacto knife, or dental pick will work wonders but don't count on it). Otherwise, cleaning and lubrication may be all that is needed. Remove the dirt and the old gummed up lubricants and lubricate the tracks and/or gears using the proper oil or grease. (See the sections: "Lubrication of CD players"

If these tests come up negative, check out the pickup motor for defects such as a shorted or open winding, partially shorted commutator, or dry or worn bearings. See the section: "Testing of motors".

As a double check, disconnect the pickup motor from its driving circuit (extremely important!) and run it in both directions with a 3 V (2 AA) battery to confirm electrical and mechanical operation.

In addition, check the proper functioning of any limit switches that are present on the optical deck.

There will almost always be one for the inner (reset - startup) track and there may be one for the outer track (end-of-disk) as well. Run the pickup manually or using the battery (see above) to both ends without forcing and check for reliable operation of the switch contacts.

\*\*\*\*\* MISCELLANEOUS PROBLEMS \*\*\*\*\*

Audio problems: -----

Silly me, what other kinds of problems are we talking about. OK, I should have said audio signal chain problems.

There is a distinct boundary between the digital section where audio information is encoded digitally and the analog domain where it is an electrical waveform.

Problems with the digital circuitry: -----

Problems in the digital domain will usually be gross - extreme noise, noise correlated with the signal level, extreme distortion, tones or frequencies that with no stretch of the imagination were present in the original music, etc.

Characteristics will be distinctly different than the kind of noise or distortion we are accustomed to in stereo equipment. Small errors in the digital reconstruction can result in totally gross changes in the audio output. For example, a single bit error if in the MSB can totally corrupt the resulting waveform. Simple errors can result in sound frequencies not present in the original. Fortunately, these sorts of errors are relatively rare as most of the circuitry is inside of very reliable LSI chipsets.

However, if the CD is recognized and appears to behave normally except that there is absolutely no audio output, there can be problems in the audio decoding LSI chips. Other than hoping for an obvious bad connection, this is way beyond the scope of anything you can hope to repair without the service manual, test equipment, and a miracle.

Problems with the analog circuitry: -----

Problems in the analog sections - D/A, sample-and-hold, post analog filter - produce effects that are more familiar: noise, decrease in signal strength, and distortion. Except for parts of the D/A which may be shared, there will be identical left and right channels to compare if an audio problem develops.

If only one channel is affected, then the problem most likely has nothing to do with tracking, the laser, or the mechanism. Coming off of the disc, the L and R channels are interleaved on a sample (16 bit word) basis so any disc or pickup problem would equally impact both L and R.

You are left with the D/A and sample-and-hold or D/As or the final analog filter. Many CD

players multiplex the D/A between L and R, so in these, even the D/A is ruled out since most of its circuitry is common.

With a single D/A, there will be sample-and-hold circuits for each channel as well.

Players without digital filters (or oversampling) have fairly complex analog filters after the D/A. A bad or noisy component could conceivably be your problem. Even players with fancy oversampling have some kind of a final analog filter.

On an older player, there is probably a lot of discrete circuitry in the audio section.

If you can get to the components in the analog filter (some are potted), then with a test CD which has a 'silence track' and a scope or signal tracer, you should be able to find out where the noise is being introduced. If it has separate D/As, then one of these would also be suspect.

Swapping components one at a time between the identical left and right channels is also a valid diagnostic technique.

Don't overlook the simple problems of dirty contacts on the RCA jacks or bad connections where they are soldered to the main circuit board.

Boomboxes and compact stereo systems: -----

These combine a stereo receiver and a single or dual cassette deck, and/or a CD player or changer, and a pair of detachable speakers, into a single unit. Most are fairly portable but larger boomboxes and compact stereos may require a forklift to move any great distance.

While the individual subsystems - CD player for example - are usually relatively self contained electrically except for a common power supply, mechanically, everything tends to be jumbled together - even on units that have an outward appearance of separate components. Both cassette transports are usually driven from a single motor. Getting at the CD player may require removal of both cassette decks, audio amplifier, and power supply. Working on these is not fun. As usual, take careful notes as you disassemble the unit and expect it to require some time just to get to what you are after. Be especially careful when removing and replacing the individual modules if printed flex cables are used for interconnections.

Refer to the relevant sections on cassette transports, loudspeakers, and power supplies for problems with these units.

Since these do get abused - bumped, dropped, dunked, etc., bad connections, and other damage is very common. See the sections: "General intermittent or erratic behavior" as well as "Noisy or intermittent switches and controls".

CD player was dropped or got wet: -----

I have never heard of a component CD player being dropped or rained on. However, this does happen to portables. While a service shop may not even want to tackle such a unit, it is quite possible that damage is minimal - even for a CD player.

With a CD player that has been dropped, unplug it from the AC line or remove the batteries immediately. This will prevent further damage should anything be shorting internally.

For one that has gotten wet, dry it immediately (you knew that!).

See the document: "Notes on the Repair of Audio Equipment and other Miscellaneous Stuff" for more info on restoration of abused audio equipment.

Repairing flexible printed cables: -----

It seems that more and more consumer devices from pocket cameras to laptop computers are being built with miniature multiconductor flexible printed cables. Very often one or more traces to develop hairline cracks due to repeated flexing. In addition, damage from moving circuit boards and modules during servicing is all too common.

Needless to say, repairing any kind of flex cable is a real pain. I have succeeded by carefully scraping the plastic off with an Xacto knife and then soldering fine wire (#30 gauge wire wrap for example) to the traces. This presumes that the conductors on your cable will even take solder. I then cover up the joints with a flexible sealer for electrical and mechanical protection.

However, you need to make sure that the wire you use can be flexed or that the joint is set up in such a way that the wire does not flex much - else you will just end up with broken wires pretty quickly.

Soldering from end point to end point if possible may be preferable. Even going to only one endpoint would reduce the risk of immediate damage and reliability problems in the future.

With multiple traces broken or damaged, you are probably better off replacing the cable entirely.

Testing the optical pickup: -----

See the special section "Testing of Optical Pickup Assemblies" for detailed procedures for determining basic functionality of most of the optical, electronic, and mechanical components in the pickup assembly. These techniques do not require sophisticated test equipment and will identify most common failures. However, you should not consider such involved tests until you have eliminated other possibilities for your particular problems.

\*\*\*\*\*  
\*\*\*\*\* SERVO SYSTEMS AND CD PLAYER ADJUSTMENTS \*\*\*\*\*  
\*\*\*\*\*

Servo systems: -----

There are several servo systems in a CD player:

1. Focus - maintains a constant distance to within 1  $\mu\text{m}$  (1/25,000th of an inch!) or so between the objective lens and the disc. This must be maintained even with a slightly warped or uneven disc and in a portable player, with a certain amount of movement as well. Focus is accomplished with a voice coil type of positioner (similar to operation of a loudspeaker) using optical feedback from the disc surface. See the section of 'Startup Problems' for a description of how this and fine tracking (below) operate.
2. Fine tracking - centers the laser beam on the disc track (to within a fraction of a  $\mu\text{m}$ ) and compensates for side-to-side runout of the disc and player movement. This also uses a voice coil positioner and optical feedback from the disc surface. (Note: on rotary type pickups, there may be no separate tracking coil as its function is combined with the rotary positioner.)
3. Coarse tracking - moves the entire pickup assembly as a function of fine tracking error exceeding a threshold or based on user or microcontroller requests (like search or skip). Coarse tracking uses several types of positioners depending on performance requirements. It may either be a worm drive, a gear drive, a linear motor, or rotary positioner - in order of increasing access speed.

The linear motor and rotary positioner have no gears and simply use a coil and permanent magnet to move the entire pickup very quickly - similar to a voice coil but on a larger scale. CDROMs, especially the high performance models, usually use this type of actuator to achieve their relatively fast access. These may have some type of lock to prevent the pickup from banging around when the unit is moved with power off. Note: for a CDROM drive that uses a caddy - always remove the caddy before transporting the drive or the equipment that it is in. The loading of the caddy often unlocks the pickup permitting it to flop around during movement and possibly being damaged.

A linear motor or rotary positioner driven pickup should move very smoothly and easily by hand when unpowered and unlocked.

Note that the use of a rotary positioner is no guarantee of fast response. One of the earliest CD players - a Magnavox unit apparently manufactured by Philips - has about the slowest track seek time I have ever seen and uses a rotary positioner. Watching it go from one track to another is like watching an inch worm crawl along - ssst, ssst, ssst (the sound made as the focus actuator vibrates while crossing tracks), ssst, ssst.



4. Spindle speed - maintains constant linear velocity (CLV) of disc rotation based on a PLL locking to the clock signal recovered from the disc. Spindle drive is most often done with a permanent magnet DC motor connected to the disc platform. It may be similar to the other motors in CD players and VCRs, (as well as toys for that matter), or a higher quality brushless DC motor.

Play adjustments: -----

You will see a circuit board, hopefully in your unit it is readily accessible with component markings. For each servo, there will be 1 or 2 pots to adjust. Unfortunately for our purposes, some CD players have no adjustments! In this case about all you can do is confirm that the lens is clean and clean and lubricate the mechanism.

The adjustments will be labeled something like:

1. Focus - F.G. (focus gain), F.O. (focus offset)
- 2,3. Tracking - T.G. (tracking gain), T.O. (tracking offset), maybe others.
4. Spindle PLL, PLL adj., Speed, or something like that.

**DO NOT TOUCH THE LASER POWER ADJUSTMENT** - you can possibly ruin the laser if you turn it up too high. Sometimes, just turning it with power applied can destroy the laser diode due to a noisy potentiometer. This adjustment can only be made properly with the service manual. It may require an optical power meter to set laser output. Very often the adjustment is on the optical pickup itself so it should be easy to avoid. Sometimes it is on the main PCB. The laser optical power output is feedback controlled and unlikely to change unless the laser is defective - in which case adjustments will have little effect anyway. If you run out of options, see the section on 'Laser Power Adjustment' - last.

**DO NOT JUST GO AND TWEAK WILDLY.** You will never be able to get back to a point where the disc will even be recognized (without test equipment and probably a service manual).

First, somehow mark the EXACT positions of each control. Some of these may require quite precise setting - a 1/16 of a turn could be critical, especially for the offset adjustments.

Sometimes, there will be marked test points, but even then the exact procedure is probably model dependent.

Adjustment procedure for noise or skipping: -----

The assumption here is that you can get the disc to play but there is audio noise skipping, or other similar problem.

Play a disc at the track that sounds the worst - put it into repeat mode so it will continue for awhile. Get it to play by whatever means works.

Repetitive noise at disc rotation frequency: -----

Try to locate the adjustments for focus. Try the focus offset first, just a hair in each direction. If you go too far, you will lose focus lock totally, the servo will go into focus search mode and/or the unit will shut down. Return the control to the exact original position if there is no improvement. You can also try gain, but in my experience, the gain controls are not critical to normal play but determine how the unit will handle dirty and/or defective discs. However, if they are way off, there could be general problems. Too low a gain setting (this applies to focus as well as tracking) will make the unit very prone to skipping as a result of minor bumps. Too high a setting will make the unit skip as a result of minor disc defects.

Short distance skipping or sticking: -----

Try to locate the adjustments for tracking. Try the fine tracking offset first, just a hair in each direction. If you go too far, you will lose servo lock totally, the pickup will slew to one end of the disc, and/or the unit will shut down. Return the control to the exact original position if there is no improvement. Then try the other tracking offset if there is one and also the gain (though this is probably not the problem).

Always return each control to its original position after the test so you don't confuse things more.

General servo adjustment procedure: -----

If you have a service manual for your player, by all means follow its recommendations or at least read through its adjustment procedures before attempting the one given below.

If your CD player has a TEST MODE, see the section: "Pioneer PD-M400/500/600 etc. servo adjustment procedure" and modify it accordingly. The following procedure is for a typical unit without such a test feature. It assumes that the unit is functional but internal controls are not in their correct position. This might be the case if you violated rule #1 - never wildly tweak any internal adjustments! Or, if a major subassembly like the optical pickup or mainboard has been replaced. If you have not touched the internal controls and no major parts have been replaced, there is no need to perform this procedure. Use techniques and observations discussed elsewhere in this document.

The following are assumed:

\* Controls on the main board are in an unknown state but not any laser power adjustments (hopefully, these were on the optical pickup itself or its flex cable and were not touched.

\* The player is otherwise functional - there is no physical damage.

You may need to modify this procedure based on your particular model. Some of the adjustments may go by different names or be non-existent. Use your judgement. Except for the laser power adjustment, which should be avoided, it is unlikely that any settings of these controls will result in permanent damage.

Some of these adjustment will need to be performed while the unit is in the startup sequence attempting to read the disc directory. Until focus and possibly tracking and CLV lock are established, it may give up fairly quickly. You will just need to keep cycling power or opening and closing the drawer to get it to repeat the attempt. Once some subset of the servo adjustments are set within reasonable limits, the player may continue to spin the disc ad-indefinitum.

1. Precisely mark the current positions of all internal adjustments - just in case they were already set correctly!
2. Set all main board controls to their midpoint.
3. Adjust TR BAL (Tracking Balance) to the center of the range over which the sled remains stationary. Outside this range, the pickup will slew to one end or the other. Not all CD players have this control. A CD may need to be in place for this adjustment to have any effect. If you are unable to get the pickup to remain stationary, try fine tracking offset (TR.OFF) as well.

The following two items should be done with no disc in place. If your player does not have suitable test points or if these controls have no effect without a disc in place, skip them.

4. While monitoring the testpoint for focus error (e.g., TP.FE), adjust focus offset (FO.OFF) for 0 volts (+/- 10 mV or so). This may not be the optimal setting but will get you in the ballpark.
5. While monitoring the testpoint for tracking error (e.g., TP.TE), adjust fine tracking offset (TR.OFF) for 0 volts (+/- 10 mV or so). This may not be the optimal setting but will get you in the ballpark.
6. If you have a DMM, VOM, or scope, put it on the Focus OK testpoint if there is one.
7. Load a disc and press PLAY if necessary to initiate the startup sequence.
8. Confirm that focus is established. There is an adjustment range for Focus Offset over which focus will be reliably achieved. Outside this range:

\* The lens will hunt up and down - possibly with clicking sounds as it bumps into the end stops.

\* The Focus OK testpoint will not be asserted or will be jumping around as well.

\* The disc may never start spinning or spin erratically (model dependent).

\* Single play units will give up and enter stop more with display of 'disc', 'no disc', 'error', etc. Changers will come up with similar display and then move on to the next position of the carousel or magazine.

Center the focus offset within the range for which focus is stable if it was not already there.

At this point there is a fair chance that the disc has started to spin and even that the disc directory has been displayed. If not, there are still two sets of adjustments remaining.

9. With focus stable, the disc should spin up. It needs to reach and lock at about 500 rpm - roughly 8 revolutions per second. If it does not move or overspeeds, try adjusting the PLL/CLV control (may be called PLL.ADJ, VCO.FR, CLV.ADJ, etc.). Note: this assumes that the spindle motor and driver are in good condition. If there is any doubt, see the section: "Testing of motors".) WARNING: if the disc spindle speed runs away, turn power off and wait for spindle to stop completely. PLL/CLV control may be set to high; turn it counterclockwise 1/4 turn and start try again. There will be some range of this control where the speed will not run away but will be within the required limits.

Now, there is an even better chance that the disc has started to spin and that the disc directory has been displayed. If not, there is still one set of adjustments remaining.

10. Fine tracking offset may still not be quite right. Try some slight adjustments on either side of the current position. You may have to cycle power or open and close the drawer if you go too far. Some adjustments of alternately fine tracking offset and PLL/CLV may be needed.

Hopefully, you now have a disc directory and play may be operations though perhaps with audio noise and/or skipping or sticking.

The following are best done with a scope monitoring the 'Eye' pattern or other testpoints but if you do not have one, use your ears.

11. Adjust PLL/CLV control to midpoint of range in which disc plays correctly. Test this at both the start and the end of a full length (74 minute) disc. The optimal setting will result in the control being centered within the range over which the player works reliably at both ends of the disc.

12. Adjust any RF Offset (RF.OFS) control to the midpoint of the range over which play continues normally with no audio noise.

13. Set Focus Gain (FO.GAIN or FO.G) to the midpoint of the range over which it locks.

CAUTION: the disc may enter a runaway state if you go to far. Check at both the beginning and end of the disc. Focus gain may need to be increased if the player is overly sensitive to bumps or disc wobble. It may need to be decreased if sensitivity to disc defects is too high.

14. Set Tracking Gain (TR.GAIN or TR.G) to the midpoint of range over which it locks. CAUTION: the disc may enter a runaway state if you go to far. Check at both the beginning and end of disc. Tracking gain may need to be increased if the player is overly sensitive to bumps or disc wobble. It may need to be decreased if sensitivity to disc defects is too high.

15. Press STOP and then PLAY again to confirm that the disc loads properly and the directory comes up quickly and the music starts without excessive delay, hunting, or hesitation.

16. Test forward and reverse search and seek functions for proper behavior. Some slight adjustments to tracking balance or fine tracking offset may be needed to equalize the forward and reverse search or seek speed. 17. Player should now operate normally. However some tweaking of the gain controls may be necessary (as described above) for optimum defective disc and track seek performance over entire disc.

Note: if you have an oscilloscope capable of at least 5 MHz bandwidth, you can optimize the amplitude and stability of the 'eye' pattern at the RF testpoint by going back and touching up the focus and fine tracking adjustments.

Low laser power: -----

Indications of reduced laser power include erratic startup, noisy playback. excessive variation of playback quality depending on the particular disc, or total lack of startup.

WARNING: improper adjustment of the laser power may result in the absolutely instant destruction of the laserdiode - the heart of your CD player. There will be no warning. One moment you have a working laserdiode, the next you have a DELD - Dark Emitting LaserDiode. Read the relevant sections fully before attempting any adjustments.

Nothing will help a dead laserdiode - whether as a result of your efforts or natural causes - short of replacing the optical pickup.

Very likely, low laser power indicates a sick laser as well and adjustments will have limited if any effect since optical feedback normally maintains laserdiode output at the proper level and it may be doing all that is possible.

If you have the service manual and it provides a procedure not requiring a laser power meter (which you probably do not have), then by all means follow that procedure.

Otherwise, see the section "Laser power adjustment" for procedures that may be used as a last

resort.

Optical alignment: -----

Unless the unit was dropped, optical realignment of the laser assembly is not likely to be needed. All critical components are screwed, sealed with loctite, or glued, and should not change alignment under normal use. Don't fall for the line 'CD players are very delicate and will need frequent alignment - buy our extended service plan'. CD players are remarkably robust. Portables, even when nibbled on by large dogs, often survive unscathed. I even carried a component type CD player home from a garage sale 5 miles on the back of a 10 speed road bike over city streets complete with potholes! No problems. In fact, it improved. The seller claimed that it was broken but I could find nothing wrong! One possible exception is for automotive units which are subjected constantly to bumps and vibration which eventually take their toll.

If you really believe that optical alignment is needed, I strongly recommend that you obtain the service manual. Special test discs or jigs may be required and some test equipment will be required. As with other adjustments, make sure you can get back to your starting point should the need arise. Again. eliminate other possibilities first if possible.

\*\*\*\*\* MOTORS AND SPINDLES \*\*\*\*\*

Small motors in CD players: -----

Conventional miniature Permanent Magnet (PM) motors are usually used for:

- \* drawer/tray opening/closing.
- \* spindle rotation.
- \* pickup position (coarse tracking) unless the unit uses a linear motor or rotary positioner drive.
- \* disc changing (changers only).

These are DC motors with commutators and metal brushes and are very similar in construction and quality to typical motors found in cameras, toys, portable tools, and other electronic equipment like VCRs and audio cassette decks.

They usually run on anywhere from a fraction of a volt up to 10 or 12 volts DC on-off (e.g., drawer) or from a servo controller (spindle).

Some CD players and CDROM drives use brushless DC motors for spindle driver rather than the cheap PM brushed variety. The commutation circuitry for these may be external to the motor itself. Troubleshooting will probably require a schematic.

Sled movement in high performance CD players and CDROM drives often uses either a linear or rotary direct drive (voice coil) mechanism. Since these are integral parts of the coarse tracking servo system, the only thing that can be tested without a schematic is for coil continuity.

Problems with small PM motors: -----

These motors can fail in a number of ways:

- \* Open or shorted windings - this may result in a bad spot, excess load on the driver, or a totally dead motor.

- \* partial short caused by dirt/muck, metal particle, or carbon buildup on commutator - this is a common problem with spindle motors which fail to reach proper startup speed.

- \* dry/worn bearings - this may result in a tight or frozen motor or a spindle with excessive runout.

Testing of motors: -----

If your player uses a brushless DC motor for the spindle then you may not be able to perform any electrical tests as the commutation control may be external on the circuit board somewhere. These do not fail very often, either.

An open or shorted winding may result in a 'bad spot' - a position at which the motor may get stuck. Rotate the motor by hand a quarter turn and try it again. If it runs now either for a fraction of a turn or behaves normally, then replacement will probably be needed since it will get stuck at the same point at some point in the future. Check it with an ohmmeter. There should be a periodic variation in resistance as the rotor is turned having several cycles per revolution determined by the number of commutator segments used. Any extremely low reading may indicate a shorted winding. An unusually high reading may indicate an open winding or dirty commutator. Cleaning may help a motor with an open or short or dead spot as noted below.

A motor can be tested for basic functionality by disconnecting it from the circuit board and powering it from a couple of 1.5 volt alkaline cells in series (3V). Sometimes, an erratic motor can be measured with an ohmmeter by observing the resistance across its terminals while turning it slowly by hand. There should be a periodic variation in resistance determined by the number of segments on the commutator. Any very asymmetric change in resistance may signify a shorted or open segment.

Reviving a partially shorted or erratic PM motor: -----

Dirt or grime on the commutator can result in intermittent contact and erratic operation. Carbon or metal particle buildup can partially short the motor making it impossible for the controller to

provide enough voltage to maintain desired speed. Sometimes, a quick squirt of degreaser through the ventilation holes at the connection end will blow out the shorting material. Too much will ruin the motor, but it would need replacement otherwise anyway. This has worked on Pioneer PDM series spindle motors.

Another technique is to disconnect the motor completely from the electronics and power it for a few seconds in each direction from a 9 V or so DC source. This may blow out the crud. The long term reliability of both of these approaches is unknown.

**WARNING:** Never attempt to power a motor with an external battery or power supply when the motor is attached to the circuit board - you may blow electronic components on the circuit board and complicate your problems.

It is sometimes possible to disassemble the motor and clean it more thoroughly but this is a painstaking task best avoided if possible.

Motor bearing problems: -----

A dry or worn bearing can make the motor too difficult to turn properly or introduce unacceptable wobble (runout) into the shaft as it rotates.

Feel and listen for a dry bearing:

The shaft may be difficult to turn or it may turn with uneven torque. A motor with a worn or dry bearing may make a spine tingling high pitched sound when it is turning under power. A drop of light machine oil (e.g. electric motor oil) may cure a dry noisy bearing - at least temporarily.

For spindle motors (these are the only motors in CD players where runout is critical), try wiggling the shaft from side-to-side - any detectable movement is an indication of runout. At some point, this will be bad enough such that the focus and tracking servos will be unable to compensate for the runout and audio noise and skipping may result. Some oil may help but a spindle motor with a worn bearing will require replacement eventually. Furthermore, it may prove impossible to reach the bearing(s) to lubricate them properly.

See the section: "Spindle motor problems" for more information.

Spindle motor problems: -----

The following are some indications that the spindle motor may be defective or need attention. However, insufficient spindle motor voltage or current could also be due to spindle motor driver faults, incorrect power supply voltages, or logic problems.

\* Focus is successful but disc does not spin (dead motor or dead spot on motor, shorted motor, bad connection).



\* Disc spins but at too slow a rate or is erratic or needs some help (weak motor or dead spot). Reading of disc directory may be erratic. (Try helping motor out by hand).

\* Voltage across spindle motor is only 1 V or less while attempting to spinup and read the directory and climbs to 5 V or more with the motor disconnected (partially shorted motor).

\* Spindle bearing runout is excessive (i.e., detectable by wiggling the spindle from side to side) or spindle motor bearing is dry or tight (try lubricating if possible).

\* Repetitive noise or dropouts at the disc rotation frequency or twice the disc rotation frequency. This may get worse toward the end or outer tracks of the disc. (Excessive spindle bearing runout or bad windings).

Check the motor before replacement (see the section: Small Motors in CD Players for general motor problems and testing). You should be able to easily confirm or eliminate the spindle motor as the cause of your problems. If either of the cleaning or rejuvenation techniques make a significant difference in performance, then the motor is almost certainly at fault.

The spindle motor is often blamed for everything from long distance skipping (coarse tracking problem) to disc spinning too fast or in wrong direction (a control problem). Spindle motors do fail but they are not at the root of all problems.

Spindle motor replacement: -----

Mark the height of the old spindle platter before you attempt to remove it. The best approach is to make a shim that will fit between the bottom of the spindle platter and the motor as a stop. The height is usually specified to a precision of 1/10 of a mm. Too low or too high and the disc may rub. This is probably overkill - 1/2 mm is probably good enough but try to get it as close as possible. The focus servo offset adjustment will make up for any height error in so far as focus is concerned.

The spindle is often press fit and difficult to remove without damage. It is critical that when the spindle is replaced, it be mounted perfectly with no wobble. If you can obtain a new spindle platter with the new motor, this is the best option. If not, take every precaution to prevent damage to the spindle platter during removal - even if it means destroying the old motor in the process.

When press fitting the new spindle, the use of an arbor press or drill press is highly recommended. Put a block of wood under the bottom of the motor and your previously made shim between the spindle platter and the motor. Press straight down - slowly and firmly. Err on the side of being too high and check the height. Repeat until you get it perfect. It is much easier to press a little more than to raise the height if you should go too far.

If there is a set screw, your job is much easier. Other mounting schemes may be employed - use

your judgement in replacement procedure. For non-press fit installations, a drop of loctite or nail polish will reduce the chance of it working loose.

\*\*\*\*\* NOTES ON SPECIFIC EQUIPMENT \*\*\*\*\*

Pioneer PDM series test mode: -----

The TEST mode available on some CD players is extremely useful for narrowing down problems. The following are for the Pioneer PDM series of CD changers:

\* Press TEST while turning POWER ON to enable TEST mode. The TEST MODE button is located on the main board.

The servos can then be controlled from the front panel:

\* STOP turns all servos OFF. \* TRACK FWD (>>|) enables FOCUS servo (and loads disc 1 in changer). \* PLAY enables SPINDLE servo. \* PAUSE enables TRACKING servo. \* MANUAL SEARCH FWD (>>) or REV (<<) to move the optical pickup.

Power cycle to return to normal mode.

Pioneer spindle motor voltage (operating normally):  
-----

Spinup: >2.5 v. Time to lock (est): 1-2 sec.

Start of disc (500 rpm): 1.0 v. End of disc (200 rpm): .5 v.

Pioneer spindle motor problems: -----

When bad, spindle servo drive tops out at .6 V and 100 ma. Player is unable to spin up to required 500 rpm to read disc directory.

While exact cause is unclear, theory is that large voltage applied at startup followed by long periods of very low voltage (.5-2 V) operation allows conductive crud (carbon) to build up on commutator eventually reducing resistance to the point where the driver cannot apply enough voltage to achieve 500 rpm.

A short squirt of degreaser through motor access hole had an immediate dramatic effect returning operation to normal. It is not known how long this will last. (Also see alternative procedure in section on motors.)

Collateral symptom: Spindle motor servo drive IC becomes quite warm when attempting

to power shorted motor. However, it does not appear to be harmed.

Use TEST mode to play disc at outer track. If this is normal, then spindle motor is probably bad as the rotation speed at the outer tracks is less (200 rpm) and a partially shorted motor may still run fast enough for this.

Pioneer PD-M400/500/600 etc. servo adjustment procedure:

-----

The following procedure assumes that unit is functional but internal controls may have been moved from their correct position. This procedure has been determined experimentally and is subject to change without notice. If you have not touched the internal controls, there is no need to perform this procedure. Use techniques and observations discussed elsewhere in this document.

Note: this procedure also applies (with obvious changes) to many Pioneer single disc players as well as other Pioneer manufactured equipment.

Assumptions:

\* Controls on the main board have been moved or are in an unknown state but not on the flex-cable or optical pickup assembly.

\* The player is otherwise functional - no physical damage.

1. Set all the main board controls to their midpoint.
2. Power up the unit in TEST MODE (hold down the TEST button while powering on).
3. Adjust TR.BAL (Tracking Balance) to the center of the range over which the sled remains stationary. Outside this range, the pickup will slew to one end or the other.
4. While monitoring TP1-6 (FO.ER, Focus Error) with a VOM or DVM, adjust FO.OFS (Focus Offset) for a reading of 0V +/- 10 MV. Note: I have found that on some players, this may not actually be quite optimal and fine adjustment be beneficial.
5. While monitoring TP1-2 (TR.ER, Focus Error) with a VOM or DVM, adjust TR.OFS (Tracking Offset) for a reading of 0V +/- 10 MV. Note: I have found that on some players, this may not actually be quite optimal and fine adjustment be beneficial.
6. Load a magazine with a disc in slot 1 and press >>|, TRACK SEARCH Forward. This should load the disc and enable focus servo.
7. Use MANUAL SEARCH REV (<<) to position sled at beginning of disc.

8. Press PLAY. This enables the spindle servo. Disc should now spin up and lock at around 500 rpm. If disc does not start or appears not to reach correct speed, check voltage on spindle motor. It should be greater than 2.5 volts during spinup. The most common cause of low voltage is a dirty partially shorted commutator/brush assembly inside the motor; clean or replace as necessary. WARNING: if the disc spindle speed runs away, turn power off and wait for spindle to stop completely. VCO control may be set to high; turn counterclockwise 1/4 turn and start from the beginning.

9. Press PAUSE. This locks the tracking servo. The display should show the disc TRACK and TIME. Alternately pressing >> or << should move pickup, then press PAUSE to start play again. Audio will be correct at output. Correct display and sound only near end of disc indicates a spindle motor unable to achieve sufficient speed (see above).

10. Adjust the VCO control to the midpoint of range in which disc plays correctly.

11. Set RF.OFS to the midpoint of the range over which play continues normally.

12. Set FO.GAIN to midpoint of range over which it locks. CAUTION: the disc may enter a runaway state if you go to far. Check at both the beginning and end of the disc. FO.GAIN may need to be increased if the player is overly sensitive to bumps or disc wobble. It may need to be decreased if sensitivity to disc defects is too high.

13. Set TR.GAIN to the midpoint of range over which it locks. CAUTION: the disc may enter a runaway state if you go to far. Check at both the beginning and end of the disc. TR.GAIN may need to be increased if the player is overly sensitive to bumps or disc wobble; it may need to be decreased if sensitivity to disc defects is too high.

14. Press STOP. The disc should unload. Exit TEST MODE by turning power off and on again. Confirm that the disc loads properly and that the directory comes up quickly and the music starts without excessive delay, hunting, or hesitation.

15. Test forward and reverse search and seek functions for proper behavior. Some slight adjustments to tracking balance or fine tracking offset may be needed to equalize the forward and reverse search or seek speed.

16. The player should now operate normally. However some tweaking of the gain controls may be necessary (as described above) for optimum defective disc and track seek performance over entire disc.

Note: if you have an oscilloscope capable of at least 5 MHz bandwidth, you can optimize the amplitude and stability of the 'eye' pattern at the RF testpoint by going back and touching up the focus and fine tracking adjustments.

Notes on Sony CDU31/33A CDROM drives. -----

Both these drives use similar optomechanical technology. The CDU31A is 1X (though I have heard that some versions of this may be 2X, unconfirmed) and CDU33A is 2X.

Many have complained about the lack of a motorized tray. What this does provide is a very simple robust mechanical design. A solenoid latch keeps the drawer shut. When the solenoid is activated (or the emergency release is pressed) the drawer pops out about an inch. Pulling the rest of the way is manual. The movement of the drawer clamps/unclamps the disc to the spindle with a powerful magnet. Except from gross abuse, there is little to go wrong mechanically.

There are only two major components: the Printed Wiring Board where all the active electronics are located and the Optical Deck including laser, optics, and pickup worm drive mechanism.

The other parts include the upper plastic casting and metal shroud, solenoid latch assembly, right and left guide rails, drawer assembly, and front bezel, two springs, bottom plate, 6 screws.

There are only two electrical connectors inside: one flat printed cable linking the PWB and optical deck and a two pin connector supplying power to the eject solenoid. This is in pleasant contrast to some other CDROM drives I have seen with a half dozen or more small connectors spread all over the PWB making removal and testing very difficult and risky.

#### Disassembling the Sony CDU31/33A CDROM drive: -----

The only major cautions are to not lose any of the small screws or springs and to avoid damaging the multi-conductor flexible cable linking the electronics to the optical assembly.

The following procedure takes about 5-10 minutes:

0. Place the unit upside-down on a soft surface.
1. Remove 4 philips head screws securing bottom cover. Set bottom cover aside.

You will now have access to the electronic adjustments for focus, tracking, etc. If this is what you are after, no further disassembly is needed.

2. Unclip the front bezel. Slide it out with the tray as far as it will go. You may need to manually activate the eject mechanism with a paperclip.
3. Remove 2 philips screws securing Printed Wiring Board (PWB). Gently lift PWB and disconnect connector to latch solenoid assembly in front of unit.
4. Gently lift PWB further and disconnect flexible cable connector on optical assembly. Mark the orientation so there will be no doubt about getting it correct if you need to reassemble on the

workbench for testing. There is a latch at each end which you push away from the connector 1 mm or so. The cable will then come out easily.

You now have partial access to the optical assembly sled drive. Cleaning and lubrication of these components is now possible.

5. Lift the latch solenoid assembly up, remove and set aside.
6. Using a pair of fine needlenose pliers or tweezers, disconnect and set aside the two tray retraction springs. Note their position and orientation.
7. Remove the two plastic guides - one on each side. There are little tabs that you will need to depress and then lift each guide straight up.
8. The entire deck can now be slid forward and lifted off. The opto/mechanical assembly can then be removed from the tray. Set the tray aside.
9. If you prop up the PWB and reconnect the flexible cable - note the orientation marks you made previously - you can then run the drive with full visibility of the mechanism and optics. With a CD in place, there is no danger to you from the laser beam. Just make sure the PWB cannot short to anything and that the whole affair cannot tip over.

Reassemble in reverse order. Be especially careful reinstalling the flex cable. Make sure no wires are being pinched and that nothing is obstructing free movement of the optical pickup. This is actually pretty easy for this drive.

\*\*\*\*\* TESTING OF OPTICAL PICKUP ASSEMBLIES \*\*\*\*\*

Introduction: -----

Identifying front-end problems in CD players, CDRom drives, laserdisc players, and other optical drives is often thought to be a mysterious and difficult task. This section describes basic techniques confirming functionality of the laserdiode, focus voice coil actuator, tracking voice coil actuator, and photodiode array. No exotic test equipment is required.

It is strongly recommended that you read and become familiar with the other information in this document. Don't immediately conclude that your problem is in the optical pickup. It is likely elsewhere and you will not need to undertake the testing described below.

If the unit is able to read the disc directory, if even erratically, then these tests are unnecessary (unless you suspect an intermittent in one of these subsystems) as all of major parts of the laser pickup assembly must be properly functioning in order to do this. However, this does not

guarantee that there are not some marginal components such as a weak laserdiode or shorted turns in the focus or tracking coil - more on these problems later.

Don't ignore the trivial: have you cleaned the lens? Sometimes a dirty lens will result in symptoms that may be mistaken for much more serious problems.

For intermittents, first carefully inspect the pickup assembly for bad solder connections and hairline cracks in the flexible printed cables. Interlock switches may be dirty or worn. Mechanical problems may result in intermittent behavior as well.

When and why to test the pickup: -----

If you have examined the 'RF Test Point' with a scope and found a proper 'eye pattern', then as noted, these tests are not needed as this indicates proper functioning of all the major components of the optical pickup. If, however, any of the following are observed, then testing of the laserdiode, focus and tracking actuators, and/or photodiode array is suggested:

- \* The startup sequence does not complete due to obvious failure of the pickup to perform some action. For example, there is no attempt to focus.
- \* Focus appears to be established but the directory is never displayed even though the disc spins at the correct speed - or overspeeds or does not spin in correct direction (clockwise as viewed from the label side is correct for CDs).
- \* The 'eye pattern' is weak, distorted, or missing at the RF test point.

Try to eliminate alternative causes before undertaking these tests as there is a slight chance of damage due to accidents or electrostatic discharge.

Will it be worth the time and effort? Only you can decide how much your time is worth. There is a good chance that these tests will only confirm that the pickup is dead - not many of the faults you will be able to locate have easy fixes. You will learn something if that matters. However, with the cost of new single disc CD players less than \$70 and changers less than \$100, any rational analysis of the expected value for this undertaking may recommend the dumpster. But, we all know that hobbieist's time is not worth much - as in free.

Required tools, documentation, and test equipment:  
-----

Only a minimum of tools and test equipment are required for these testing techniques to be effective. An oscilloscope is desirable but a VOM or DMM can substitute in a pinch since no high frequency measurements are needed. However, we will assume a scope is available. This section does not address mechanical problems in the sled drive, or the drawer or spindle motors. These

problems are adequately handled in the elsewhere in this document. It is assumed that these components have been verified to be functional as their correct operation may be required for some of the tests described below.

A schematic will help greatly if available. Depending on the design of the unit, you may be able to infer enough about the front-end electronics to get away without one. The design of the components of the optical pickup are sufficiently similar among manufacturers to make the tests relatively model independent. What may differ are polarities of photodiodes, laser diodes, connector pinouts, etc. These can usually be determined fairly easily.

Despite the incredible precision of the focus and tracking servos, we can perform meaningful tests without sophisticated or specialized test equipment.

Also see the sections: "Troubleshooting tips" and "Test equipment".

The following tools and test equipment will be required:

1. Basic hand tools including precision jeweler's screwdrivers.
2. A VOM or DMM.
3. An oscilloscope (for photodiode/RF tests). For most of the tests, almost any scope will do as long as it has a DC coupled vertical amp. As noted above, a scope is not essential but is highly desirable.
4. A 0 to 5 volt variable DC power supply (400 mA). The power supply can be a 4-5 V 'wall wart' with a Variac. Alternatively (but not as desirable), you can use a fixed 5 V supply with a series adjustable resistor (100 ohms for focus and tracking actuator testing, 250 ohms for laserdiode testing). A highly regulated supply is not needed.
5. Resistors: 22 ohm 1W, 5 ohm 1W, 50 ohm, 1 M ohm.
6. Assorted test clip leads, a few feet of #24 solid hookup wire (RS232 quad or multiconductor phone cable is good source).
7. IR detector circuit, IR detector card, or IR sensitive camcorder (for laserdiode tests).
8. (Optional) Slow speed sweep or function generator (1-10 Hz) with low impedance output or amplifier, see text.

For the following discussions, a component CD player is assumed to be the unit under test. Make appropriate adjustments in interpretation if it is a portable CD player, CDROM drive, or optical drive.



Precautions: -----

Reread the section: "Safety" for your own protection.

To minimize the chances of damage to the laserdiode - which is extremely sensitive to static and excess current - leave its connector plugged into the main board as much as possible and do not attempt to test the laserdiode with a VOM (which on the low ohms scale may exceed the current rating of the laserdiode - poof, even if only for a microsecond.

As with all modern solid state equipment, preventing electrostatic discharges to sensitive components is critical. An antistatic wrist strap is desirable. In any case, work in an area where static is minimized - not on a carpet prone to static. Make it a habit to touch the metal chassis first to discharge yourself.

Basic description of optical pickup: -----

Also see the more detailed description of the optical pickup components and operation elsewhere in this document.

In order for information or music to be read off of a CD, several systems must work closely together:

1. Laser must be emitting a coherent beam of sufficient power and stability. Optical system must be clean and properly aligned. Laser power is maintained constant via an optical feedback loop controlling laserdiode current. Therefore, a weak laser may not be salvageable as the feedback loop may have done all that is possible.
2. Photodiode sensors must be functioning correctly for data recovery and focus and tracking feedback. In a 'three beam pickup', there are six segments: the central segments A-D are used for focus and data recovery; the outer segments E and F are used for tracking feedback. In a 'single beam pickup' segments E and F are omitted.
3. Lens must be focused to within a fraction of a  $\mu\text{m}$  of optimal to produce a diffraction limited spot. This is less than 2  $\mu\text{m}$  in diameter at the disc 'pits'. The lens is actually positioned several mm from the disc surface and is maintained at the correct distance through optical feedback controlling the lens position using the focus coil. Note:  $\mu\text{m}$  = micrometer =  $10\text{E}-6$  meter; mm = millimeter =  $10\text{E}-3$  meter. 1 meter is 39.37 inches.
4. Lens must align to within a fraction of a  $\mu\text{m}$  of the center of the track. Tracks on a CD are spaced 1.6  $\mu\text{m}$  apart. Tracking is maintained via optical feedback controlling the radial lens position using the tracking coil (or radial positioning unit on some rotary positioners).

Note that if the behavior while the CD player is attempting to read the directory changes whether

a disc is in place or not, (and there is no separate disc sensor), then some or all of these components are functioning correctly. For example, many CD players will not attempt to rotate the spindle until proper focus has been established. Thus, if the CD rotates when in place but the bare spindle does not, it is likely - though not guaranteed - that focus is being established successfully.

Testing the laserdiode while in the player: -----

Without a laser power meter, it will be difficult to fully verify laser functionality. However, determining that IR is emitted will provide a reasonable assurance of laser operation.

For this test you will need an IR detector. A simple circuit is described in the "Notes on CD Technology and Repair of CD Players and CDROM Drives", This unit is also useful for testing remote controls and other IR emitters. You can also use an IR detector card - available at an electronics distributor. In a pinch, CCD based camcorders are often sensitive to IR. It will appear as a bright spot if the laser beam is projected onto a white paper screen. However, you will probably need 3 or 4 arms to position the screen, push the play button, and hold the camcorder while attempting to view the detected spot through the viewfinder!

You will need to gain access to the lens. This may require the removal of the clamper assembly.

Once this is accomplished prepare to position the photodiode of the IR tester within 1/8" of the lens. Plug the unit in and turn it on. On portables, you will need to defeat the door interlock - use a toothpick or bit of cardboard. Sometimes a CD player will have a disc detect sensor separate from the laser assembly - this will need to be defeated in order for this test to work without a CD in place. If it is a simple optical sensor, a piece of black tape or paper should suffice.

The first thing that should happen once a CD is in place and the play button is pressed is for the laser to be powered. You should be able to detect this in a darkened room because there is usually a very faint red appearing emission which you can see as a tiny red dot of light if you look at the lens from a safe distance of at least 6 inches at an oblique angle (WARNING: Do not look directly into the lens from directly above as the invisible IR is much stronger than the faint red emission and potentially hazardous). If you see the faint red light, you know that at least power is being applied to the laserdiode.

With the laser lit, the lens should go through a few focus search cycles - between 2 and 8 typically. While it is doing this, position the IR detector above the lens. If the laser is working, you will get a positive indication of IR in about a 30 degree cone on either side of the lens. While you have no way of knowing if the power output is correct, this is a reasonable indication of laser operation. Due to the wide angle of the beam, the power decreases rapidly with distance so you will need to be very close to the lens for a positive result.

Note that if the lens moves smoothly in at least one direction (up or down), you have also

confirmed that the focus actuator is functional.

If the IR detector does not pick up a beam and you do not see the red dot, then either the laserdiode is really dead or there is no power being applied by the control circuits.

At this point, you have three options:

1. You can give up. However, you would not have gotten this far if you were likely to be defeated so easily.
2. You can attempt to obtain a schematic if you do not already have one so that you will be able to test the control circuits to determine if the laserdiode is being powered.
3. You can perform some simple but risky tests on the laserdiode itself in an attempt to light it from an external power supply. As noted below, laserdiodes are easily destroyed and you will have no warning. One nanosecond it will be a laser - the next it might be a DED - Dark Emitting Diode.

Testing the laserdiode with an external power supply:

-----

Consider the following only if there is no indication of laser output while connected to the player and you do not have schematics or a service manual to determine if the laser power circuits are functional.

Typical currents are in the 30-100 mA range at 1.7-2.5 V. However, the power curve is extremely non-linear. There is a lasing threshold below which there will be no output. For a diode rated at a threshold of 30 mA, the maximum operating current may be as low as 40 mA. A sensing photodiode is built into the same case as the laserdiode to regulate beam power. It is critical to the life of the laserdiode that under no circumstances is the safe current exceeded even for a microsecond!

Laserdiodes are also extremely sensitive to electrostatic discharge, so use appropriate precautions. Also, do not try to test them with a VOM which could on the low ohms scale exceed their safe current rating. Even connecting the test leads can blow the laserdiode from static on a bad day. In addition, always make or break power or test connections with the player turned off.

Locate the laser power connector by tracing back from the three pins on the laserdiode assembly. Note: the following only applies if the laserdiode is directly connected to the cable. If the power regulating circuit is on the pickup, you will need to trace its circuit or obtain the schematic as there are now too many variations to recommend a specific procedure.

Use the 0-5 VDC linear supply (a switching supply may put out laserdiode destroying pulses) with

a 50 ohm resistor in series with the diode. This is preferred over the variable resistor power supply as there is less likelihood of any potentially laser destroying overshoot or noise. If you do use the variable resistor, make sure it is at its maximum resistance when you start and that this is sufficient to keep the current under 20 mA. Keep in mind that a wall wart rated at 5 V may actually put out 8 V or more when unloaded - check the current into a short circuit before connecting the laserdiode.

Slowly bring the current up until you get a beam. Use an IR detector for this! If you get the polarity backwards or are actually measuring across the internal photodiode, the voltage across the diode will go above 3 volts or will be less than 1 V. Then, turn power off and reverse the leads. Note: some laserdiodes will be destroyed by reverse voltage greater than 3 V - a spec sheet will list the reverse voltage rating. The ones I have tried out of CD players were fine to at least 5 V in the reverse direction.

Without a laser power meter, however, you will have no way of knowing when the limit on safe beam power (safe for the laserdiode, that is) is reached. For this test, increase the current only until you get an indication on the IR detector or you see the red dot. You are not trying to measure power, just to see if it works at all. A typical threshold is around 30 mA. Sometimes, the operating current is marked on the pickup. If this is the case, do not exceed this current.

If you detect a beam and there was none before, then your problem is most likely located in the player's control or power circuits, not in the pickup.

Laser power adjustment: -----

If you have the service manual and it provides a procedure not requiring a laser power meter (which you probably do not have), then by all means follow that procedure.

As noted elsewhere, it is possible to destroy the laserdiode by attempting to adjust its output power. However, if you suspect a weak laser as indicated by noisy playback or poor tracking performance (not a dead one as this will not help), and have exhausted all other possibilities such as the servo adjustments - and feel you have nothing to lose, you may attempt one of the following procedures with some risk to determine if the laserdiode is at fault.

The following requires that you can play a disc - even if it has some problems with noise or tracking.

\* If you have an oscilloscope, put a probe on the RF test point. While the disc is playing, you should see the eye pattern. Mark the exact amplitude of the peaks. Also, note the 'playback quality' so you will recognize if it changes.

It may be safer to turn the laser power adjustment with player power off to avoid the possibility of electrical noise causing current spikes. Mark the exact position of the laser power adjustment

so you can get back to it if there is no effect or it makes things worse. Turn the control the slightest amount clockwise. Turn power back on and note the eye pattern amplitude. If the laserdiode is not at the limit of its power and thus bad, you should see the amplitude change from what it was.

Note the playback quality. Has it changed any? If not, then laser power is probably not your problem. If the amplitude of the eye pattern is unchanged, you either are turning the wrong control or the laser is at its power limit - and probably near the end of its life. Try the same test in the counterclockwise direction if the amplitude decreased - not every designer knows left from right.

If there is improvement, you can risk leaving the control at the new (most likely) higher power setting realizing that you may be shortening the ultimate life of the laserdiode. Do not push your luck by continuing to turn up the power unless you have exhausted all other alternatives.

\* If you do not have an oscilloscope. you can still attempt the procedure above, using audio listening exclusively to determine if there is any change. It is just a little bit riskier.

Testing the focus and tracking actuators: -----

If there is a question of whether the lens is focusing or tracking properly, perform the following. Again, if the unit is able to read the disc directory at all, then these tests are not needed. Note that if you have a CD player with a rotary positioner, there may be no separate tracking coil as coarse and fine tracking may be combined.

First, identify the cable leading to the focus and tracking voice coil mechanism. This is usually a 4 conductor cable separate from the data and laser cable (at least at the pickup end). Disconnect it from the mainboard before testing. Using a DMM or VOM, you should be able to locate a pair of coils with very low resistance - a few ohms. One of these is focus coil and the other is the tracking coil.

Construct one of the following test circuits:

1. Your 4-5 V DC wall wart plugged into a Variac with its output connected to a 22 ohm 1W resistor in series with a pair of 2 foot #24 insulated wires.
2. Your 5 V DC power supply connected in series with the 100 ohm variable resistor and 22 ohm 1W resistor with a pair of 2 foot #24 insulated wires.

Gain access to the lens for visual inspection. This may mean ejecting a disc, opening the drawer, or in some cases, actually removing the clamper. In a portable or boombox, the lens will be readily accessible. Unplug the CD player from the wall or remove the batteries - you will not be using its internal power.

Locate one pair of the two pairs of low resistance connections you identified above. With your power supply off or the Variac turned all the way down, connect the #24 leads to one of these pairs. Now, turn on the power and slowly adjust the Variac or reostat while watching the lens. If you are connected to the focus coil, you may see the lens moving up and down. If you are connected to tracking coil, you may see it moving from side to side. If there is no motion, turn off the power supply, reverse the polarity and try again. For a typical pickup, the 4-5 V power supply and minimum of 22 ohms should cause the lens to move through the entire range of motion up and down or side to side as appropriate. Once you have exercised the first coil, switch connections and repeat for the other. If the motion is jerky, the lens assembly may be dirty. Clean it carefully first with a bit of compressed air (not high pressure, a photographic air bulb is fine) and then with Q-tips and isopropyl alcohol. Do not lubricate. Repeat the tests after the cleaning.

If both the tests are positive, you have confirmed operation of the focus and tracking actuators. If either you were unable to locate both pairs of coils or one or both actuators did not move, then you have located a problem. An open coil can be due to a cable problem or a break at the coil. If the break is right at the solder connections which are usually visible once the plastic protective shroud is popped off, then it may be possible to repair it. This will require a great deal of manual dexterity and patience - the wire is really really fine.

It is still possible for there to be shorted turns in the fine coils or an intermittent that was not detected.

\* Shorted turns would reduce the frequency response of the servo, reduce the reliability of focus or tracking, and increase the needed servo driver power. A CD player that is overly sensitive to slight disc defects even after all the proper adjustments have been performed may conceivably be a result of this type of fault. An additional symptom may be an unusually hot servo driver IC. However, many of these ICs run hot normally so don't panic as the possibility of shorted turns is really quite remote.

\* An intermittent may only show up during dynamic operation or with certain particularly finicky CDs or other peculiar circumstances. The intermittent could be at the solder connections or the fine printed ribbon cable that connects the moving lens assembly to the remainder of the pickup.

Testing the photodiode array: -----

The photodiode array in an optical pickup consists of an IC with typically 4 or 6 detector segments. Four segments may be used for the less common 'single beam pickup' while 6 segments are used in the 'three beam pickup'.

These segments are usually designated A-F. A, B, C, and D are the main detector which is used for both focusing and data recovery. Segments E and F are used in a 'three beam pickup' for fine tracking feedback.

We will assume a three beam pickup for the remainder of this discussion.

All 6 photodiodes are connected to a common point which during operation has a DC bias voltage on it typically around 5 V. If they are connected common anode, it will be negative; if common cathode, it will be positive. The reason is that the photodiodes need to be reverse biased for normal operation. The outputs of the photodiodes feed several operational amplifiers which are set up to amplify the current from the photodiodes. The normal connections may be at virtual ground potential or they may feed into large value resistors.

The connector to the photodiode array is usually separate and will typically have at least 8 wires - photodiodes A-F, ground, and bias voltage.

You will need to identify the wiring. First locate the ground using the ohmmeter. Then locate the bias - it will probably go to a low value resistor and then to the supply. Another way to identify the bias wire is to turn on the player and measure each of the possibilities. The bias will be the highest or lowest and will be solid with no noise or ripple. It will probably be powered all the time.

Now for the photodiode segments. Very often the connections or some of the connections are marked on the circuit board. For example, there may be several labeled test points designated A+C, B+D, E, and F. Since the A and C segments and B and D segments are usually shorted together on the circuit board, this provided all the info needed to identify the photodiode connections. It is not important to distinguish between A and C or B and D for the following tests though you will want to be able to separate them.

With power off, there is essentially no light on the photodiode array. Unplug the photodiode connector from the main board.

Using your ohmmeter, test each diode for opens and shorts as you would test any signal diode. There should be a junction drop in the forward direction and very high resistance in the reverse direction. If you are using a DMM with a diode test mode, the junction drop will typically measure .7-.8 V. There may be a very slight difference between the readings for segments A-D and those for E and F.

Any unusual readings such as a significantly lower resistance for one of the diodes, a short or open of a particular diode, or a short between diodes, is an indication of a problem. While it is possible for there to be a cable or soldering defect, this is somewhat unlikely though bad solder connections or breaks in the flexible cables are not out of the question.

A defect found in the photodiode array will usually mean that the laser pickup is not salvageable with reasonable effort. Even if you could locate a replacement photodiode array, aligning and soldering the (most common) surface mount package would be quite a challenge without the factory jigs.

Assuming these tests do not turn up anything, the next step will verify that the photodiodes are picking up an optical signal and will evaluate the relative strengths of each segment. For this, we will need to setup one of the following. Method (2) is more straightforward but requires the optional signal generator for best results. In each case the objective is to cause the lens-disc distance to sweep through perfect focus without requiring that the focus servo loop be closed. This will then result in a signal that will include the point of maximum signal amplitude on a periodic basis. Alternative methods may be used to accomplish the same purpose.

Both techniques require the adjustable power supply previously used to test the focus coil.

1. Adjustable focus with continuously rotating spindle. For the spindle motor, you will need a 1.5 V battery or your power supply with a suitable series resistor to cause the spindle to turn at approximately 1-2 Hz (rps). Warning: disconnect the motor from the mainboard! The unavoidable wobble of any disc is essential in this case and will sweep the focus distance by more than enough to cover the entire focus range of interest.

Note: this assumes that the spindle is driven by a conventional PM DC motor. If it is a brushless DC motor, then some of the control electronics may be external to the motor and you will not be able to just provide a DC voltage to get it to rotate. If this is the case, you must use method #2.

2. Stationary spindle but sweeping focus. This is the better method but requires a signal generator for easiest use. You can do this by hand using a Variac or reostat (this is easier if you have three functioning hands). A better method is to use a 1-10 Hz sinusoid or triangle wave from a low frequency signal generator with a low impedance output or feeding an emitter follower or audio amplifier to boost the current. This signal is then fed into the coil along with the focus offset derived from your power supply.

Note: it may be possible to dispense with these test setups and just use the normal focus search of the CD player to provide the sweep. However, since we will be interfering with the proper feedback by removing selected sensors, there is no telling what the microcontroller will do. Therefore, breaking the feedback loop as we are doing is preferred. If the CD player appears to make many attempts at focus, this may be worth a shot, however.

You will also need a disc - preferably one you do not care much about as sometimes it will get scratched due to opening the drawer accidentally or something equally idiotic while the disc is still rotating.

Locate a 1 M ohm resistor and securely fasten it to a ground near the photodiode connector. Put your scope probe on the other end with its ground clipped to the same ground point as the resistor. Bend the free lead of the resistor completely over so that it will be able to hold the end of a wire like a mini-clip lead.

Make sure you remember or mark down exactly how the connector is wired so that as you remove individual wires, you will be able to get them back in the proper spot. Presumably, you have



already made a diagram of the photodiode connector wiring. Component players often have connectors with individually removable socket pins. A fine jeweler's screwdriver or paper clip may prove handy in removing these one at a time.

Turn on your power supply and adjust the focus to about midrange. Start the spindle rotating or turn on the signal generator to provide a small sweep - about 1/10 V p-p as measured on the coil should be fine.

Remove the wire corresponding to the photodiode (say, A) to be tested from the connector but leave the connector itself plugged into the main board. Set the scope for 1 V/div. vertical on a slow free running sweep.

Clip the A wire into the resistor. Now, turn on power to the CD player. While the player thinks it is focusing, slowly adjust the focus voltage while observing the scope. As you approach proper focus, you will see the signal increase (depending on polarity) greatly, pass through a maximum, and then decrease. Depending on the design of the CD player, you may need to turn it off and on several times before you locate the signal as the microcontroller may give up pretty quickly with no focus or tracking coil servos (since you disconnected the actuators). If you have the service manual it may tell you how to force the laser to be powered all the time. Leave the focus set near the middle of the region of high signal.

If you are using the signal generator to perform the focus sweep, you may need to optimize the amplitude of the signal by adjusting the signal generator output and offset from your power supply.

You probably should not need to touch the settings for the remaining photodiode segment tests.

Repeat the above procedure for each of the photodiodes A-F. All should produce fairly similar signals, say within 20 % of one another in amplitude. If A,B,C,D or E,F differ from one another by more than say, 20 %, there may be a serious optical alignment problem in the pickup (the player may have been dropped or bounced around without securing the hold-down screws, if any). Alternatively, the photodiode array may be bad. It is also possible for there to be partially shorted photodiode segments in which case, the outputs will not be independent as they should be. Loading one segment's output with a resistor may affect the output of one or more other segments.

In any of these situations, such a discrepancy in A-D will prevent the establishment of proper stable lens position at the optimal focal distance. This will prevent the formation of a proper 'eye pattern' and subsequent data recovery. A significant difference between E and F (beyond the adjustment range of the tracking or E-F balance control) will prevent proper tracking. Note, however, that the signal amplitude from A-D and E,F may differ as A-D operate off of the main beam and E,F operate off of the first order diffracted beams which are weaker. As with the basic photodiode tests above, a failure here usually will require the replacement of the entire optical assembly.

As noted, if the pickup's optical alignment is way off, there could be significant differences in

photodiode responses. On component type units, it is unlikely that the optical alignment would shift on its own. Portables that have been dropped or automotive units subject to constant bumps and vibration could have alignment problems, however. If this is your last hope, then some experimentation with adjustment of the optical alignment on a successive approximation basis might be worth the effort. Mark the original position of any adjustments and try small variations on either side to determine their effect. You might get lucky. If this eventually results in improved uniformity of photodiode response, alignment may be the problem. If you can more or less equalize the response, reconnect the servos and attempt to get an eye pattern. If you can, optimize the eye pattern stability and amplitude using the optical alignment adjustments and servo adjustments.

\*\*\*\*\* ITEMS OF INTEREST \*\*\*\*\*

What is oversampling? -----

CD audio reads 16 bit samples off of the disc at a rate of 44.1 K samples per second (for each channel). This is the 1X rate. It is possible to produce \*perfectly\* faithful sound reproduction at 1X. However, digital sampling theory and the Nyquist criterion then require an analog filter which has a flat frequency response in the audio passband - 20 Hz to 20 KHz, and 0 at 22.05 KHz (1/2 the sampling rate) and above. The filter is necessary to remove 'aliasing' artifacts which would produce frequencies in the output not present in the original recording. Such filters are possible but very difficult to design and tend to have nasty phase response as you get near 20 KHz since the filter response needs to go from 1 to 0 within a very small frequency range (20-22.05 KHz). The phase response may have an effect on stereo imaging and instrument localization. Whether you can hear any of this depends on whether you have 'golden ears' or not.

Enter oversampling. Instead of putting out the original CD samples at 44.1 KHz, digitally interpolate intermediate samples so that the D/A converter can work at 2X, 4X, 8X or more. The digital filters can be designed with very good performance and are part of the VLSI chipset in the CD player. For example, with 4X oversampling, three interpolated samples will be inserted between each original 44.1 KHz sample and the D/A will run at 176.4 KHz. An analog antialiasing filter is still needed at the output but its response only needs to go from 1 to 0 over the range 20 KHz to 88.2 KHz - a much much easier filter to design.

Which will sound better? There is a lot of hype. It may depend more on the quality of either design rather than the basic technique. So many other factors enter into the ultimate listening experience that the difference in frequency and phase response around 20 KHz can easily be overshadowed by errors introduced throughout the recording process as well as playback considerations such as speaker quality and placement, room acoustics, and listener location.

Most consumer grade CD players now use oversampling. The newest fad is the 1 bit D/A with 256X (or more) oversampling. This is largely cost driven as well: you don't even need a high quality 16 bit D/A anymore. The simplest way of describing this approach is that it is a combination of pulse width modulation and sophisticated interpolation. The net result is audibly the same as all

the others.

Golden ears and technohype: -----

You have no doubt encountered various claims of how player A uses such-and-such a technology and therefore clearly has superior sound compared, no doubt, with all others in the explored universe. There may be people who can hear such differences in noise, frequency response smoothness, and such. Perhaps even you could hear a difference under ideal conditions. However, once all the variables that make \*music\* are included - the chain from artist and recording studio, microphones, recording, mixing, and resampling as well as your speakers and room acoustics - not just sinusoids played in anechoic or resonant chambers, the very slight differences between players are virtually undetectable to human ears. If you are interested in playing test discs all day, then worry about the last percentage point of noise floor or frequency response. If you really want to enjoy the music, this stuff should not bother you. There are more important things to worry about than an undetectable blip in your CD player's frequency response curve. Anyhow, with the introduction of the DVD technology pending, your carefully optimized ultimate stereo system will be as obsolete a year from now as a 78 turntable. Consider that! Only PC technology has a shorter lifespan. I bet you won't sleep tonight.

I would be curious as to the results of any true double-blind listening tests comparing CD players implemented with differing technologies (analog vs. digital filters, 4X or 256X oversampling, 1 or 2 D/As, etc.) on actual music (not test tones) in realistic listening environments. Such tests should be with people who are interested in the overall musical experience and not just the nth decimal point of technological specsmanship. There must, of course, be no vested interests (financial or otherwise) in the outcome of such tests. I would bet that the results of such tests would make for some fascinating reading and surprises for some manufacturers of high-end audio equipment.

That last little decimal point: -----

Someone was hyping his high-end CD player (with a stratospheric price tag no doubt as well) claiming that it uses \*\*mechanical\*\* relays instead of transistors to perform the muting function (between discs or tracks) in the final audio amplifier. These mechanical relays are supposed to have less capacitance and thus not affect the 'fluency' or some other equally meaningless non-measurable characteristic of the sound. According to the same article, "only cheap CD players costing less than \$900 use transistors for muting. All more expensive players use relays". If this claim is true, then how can manufacturers claim a +/-0.3db response curve from 20Hz to 20KHz even for CD players costing a lot less than \$900?

Well, my 10 year old Technics SLP-2 uses relays and it sure cost a lot less than \$900. Shall we do a little calculation:

Parasitic capacitance, say 100 pF (much much larger than likely). Highest frequency of interest: 20 KHz.

The magnitude of the impedance of this parasitic capacitance will be:

$$|Z|=1/(2*\pi*f*C) = 1/(2*3.14159*2E+4*1E-10) = 80 \text{ K ohms}$$

Compare this to the output impedance of a typical final audio stage, say less than 1 K ohms (usually a lot less, but this will do for a back-of-the-envelope calculation). Yeh, right, I will loose a lot of sleep over that. There are better things to worry about than an immeasurable blip in your frequency response curve: Are the transistors at the very output? Oh my gosh, you better start investigating super ultra low capacitance audio cables costing at least \$1000 each with water protected oxygen free tapered oriented strand conductors. But wait: you are connecting to an amplifier with non-infinite input impedance (perhaps, horrible as it may seem, non-uniform as well)? Your setup must sound like crap! How can you even have it in the same house with you? There are so many variables involved in the reproduction of high fidelity digital audio that this is about as significant as a pimple on an elephant.

Ask for a scientifically designed and implemented A-B comparison. You won't get one because the revelations might be too shocking for the audio industry should the 'Golden Ears' fail to reliably distinguish between players at the two ends of the price spectrum.

Can a CDROM disc damage a CD player?: -----

Some CDROMs include audio tracks that are entirely playable. However, data-only CDROMs may not even be recognized by newer CD players. With older ones - designed before the CDROM standards had been developed - the player may come up with a bogus track directory. Attempting to 'play' such a disc will probably not damage the CD player but will sound, shall we say, strange. If you do this experiment, TURN DOWN THE VOLUME!!!. None of the rules which govern real-world audio frequencies and amplitudes are obeyed with data discs. You may blow out your speakers (or ear drums) if the volume is set too high or even at normal listening levels.

Converting a CD player into a CDROM drive: -----

Why anyone would seriously consider this project other than for the curiosity value is not clear, but the question does seem to pop up from time to time.

If you mean audio making a CD player into a CDROM drive. Forget it. Don't waste any neural bandwidth on such considerations. While the optics and front end electronics are similar, the CD player is missing the circuitry needed to decode the CD data, CDROMs used more involved error correction, the control inputs are not there, and it is virtually impossible to obtain detailed schematics or firmware listings.

And, in the end, it would be state-of-the-art 1X drive since the servo systems and motors in an audio CD player are not capable of operation at more tha 1X speed. You can probably pick up a 1X CDROM drive for \$10 or less. They practically come for free in cereal boxes these days

(or was that 1G hard drives? Technology moves so quickly).

Using a CDROM drive as a stand-alone CD player: -----

Since nearly all CDROM drives are capable of playing audio CDs, a natural question is whether it is possible to just supply power and be able to use an old 1X (or 2X or 10X) CDROM drive as a CD player without attaching it to a computer.

For many types, the answer is yes. These provide some way of starting play and moving between tracks on the front panel. Usually, this is a pair of push buttons which combine play, eject, and next track functions or a volume control that can be pushed to start play and move to the next track. All these CDROM drives usually need is power to operate as audio CD players. For headphone listening, just use the front panel jack. A suitable adapter will permit the line outputs in the rear to be connected to the CD or AUX inputs of your stereo system.

For those without audio play controls, this may be more difficult. It is probably not worth it for SCSI or IDE drives as special commands may need to be set up. I don't know how difficult it is with the custom interfaces like Sony, Panasonic, and Mitsumi. These may have a simpler command set but I doubt that it is just jumpering a signal to ground somewhere.

However, note that the audio performance of CDROM drives is usually a notch below that of the typical audio-only CD player. The audio circuits are basically an afterthought for a CDROM drive. Therefore, don't expect quite the same level of frequency response, dynamic range, and lack of noise as you are used to with your stereo system or even your portable CD player.

Interesting CD player signals: -----

Poking around inside a working CD player makes an excellent exercise for the student. Component CD players very often have clearly marked test points for RF, focus, tracking, and audio data. With care, there is little risk of damaging anything as long as you are not tempted to try your hand at tweaking any of the internal adjustments.

If you have nothing better to do and you have your CD player open, try to locate the test points for data, fine tracking, and focus. They may be labeled something like TP.DTA (or TP.RF), TP.FO, TP.TR.

TP.DTA or TP.RF is the data coming off of the disc having gone through only the photodiode segment combiner and preamp (probably). Using a 10:1 probe set the scope for a horizontal sweep of around .5 us/div. Try a vertical sensitivity of .2 V per division to start and adjust for a full screen display. Use internal positive triggering. While playing a disc, you should see the classic 'eye' pattern used in the communication world to characterize channel quality.

The CD player 'eye' pattern: -----

The 'eye pattern' depicted below results from the characteristics of the run length limited 8-14 modulation coding used on the CD where there are no fewer than 3 and no more than 11 clock cycles per symbol. You should be able to make out the fact that the minimum distance between channel bits is 3 with the smallest distance between bit transitions of about  $3 \times 232$  ns. The readout clock is  $1/(232 \text{ ns})$  or about 4.321 MHz.

A 'good' eye pattern will be clean, symmetric, and stable with clear visibility in the cross hatched areas. This waveform may be viewed using an oscilloscope of at least 5 MHz bandwidth.

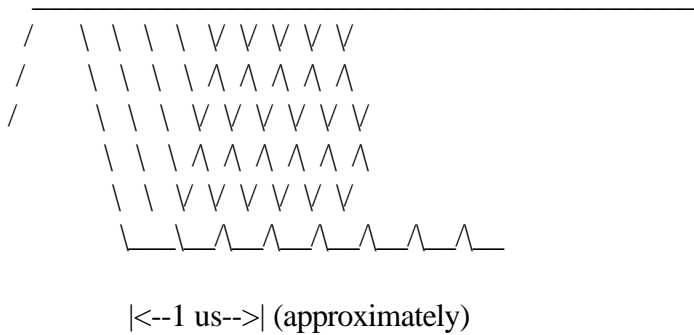

Examination of the eye pattern would be the first measurement that would be performed to determine the condition of the CD player optics and electronics. A good eye pattern eliminates most of the parts of the optical pickup from suspicion.

Focus and tracking drive or error signals: -----

TP.FO or TP.FE is the focus voice coil error signal. Monitoring this with a disc in good condition will show what looks like noise - the more or less random fluctuations in actuator current necessary to maintain proper focus within  $\pm 0.5 \mu\text{m}$  of the disc surface. On a warped disc you will see the DC level of this signal varying at the disc rotation rate. On a damaged disc, you will see higher frequency variations in the level depending on what kind of defects are present. Gently tapping the optical deck should evoke a visible effect on this signal as well as the servos correct for your mischief.

TP.TR or TP.TE is the fine tracking voice coil error signal. As with TP.FE, this will show a noise waveform with a good disc. On a disc with runout, you will see a periodic level variation at the spindle rotation frequency. Note how the DC value of this signal gradually changes as the voice coil actuator maintains lock on the track while the track spirals outward.

Eventually, this error becomes great enough to trigger the coarse tracking motor to jog the pickup a fraction of a mm and recenter it on the track at which point the signal you are watching will suddenly shift its DC level.

On a disc with scratches, there will be higher frequency deviations which will be readily visible on

a scope trace. Gently tap the optical deck from various points and observe the effects on this signal.

For both focus and tracking, you can actually hear the voice coil actuators as they compensate for minute defects or just the normal data pattern. This is the 'gritty' sound one hears from the CD audio or CDRom transport when it is operating correctly and is an indication that the laser and focus (at least) are most likely functioning properly. If you listen carefully, you can actually hear various defects by the effect they have on this gritty sound but there will be no corresponding effect in the audio outputs as there would be with an LP.

#### Focus, tracking, and error correction performance: -----

If you have a test CD (or use your regular CD), put your scope on one of audio outputs. Put some thin pieces of tape or mark with a (water soluble) felt tipped pen radially on the bottom surface of the disc to create some 'defects'. Play some tracks which have constant pure tones or silence. For widths less than the error correcting capability of your CD's LSI chipset, there should be no detectable signal degradation. See what happens as you increase the width of your 'defects'. Put your finger on the spindle or even gently touch the disc as it is rotating. Note that unless you really press hard, the disc will continue to play normally without any change in pitch. This is due to the servo control and extensive buffering of the data - unlike an LP turntable where the instantaneous speed is what determines pitch.

Other experiments are left as exercises for the student.

#### CD technology basic specifications: -----

Full Disk diameter: 120 mm (4.75").  
Disk thickness: 1.2 mm.  
Disk material: Polycarbonate.  
Track width: .6 micron (um) approx.  
Track pitch: 1.6 microns.  
Playing time: 74 min, 15 sec. (>78 min. by cheating)  
Sampling frequency: 44.1 KHz per channel.  
Number of channels: 2.  
Sample size: 16 bit linear, twos complement code.  
Bit rate: 4.3218 M bits/sec average (1X).  
Data rate (CDROM): 150-600 KBytes/second (1X-4X).  
Spindle speed: 200 to 500 rpm (1X, constant linear velocity).  
Linear speed: 1.2 to 1.4 meter/sec (1X).  
Modulation: Eight-to-fourteen modulation, RLL(3,11).  
Error Correction: Cross Interleave Reed Soloman Code - CIRC.  
Laser type: Semiconductor Diode GaAlAs.

Laser wavelength: 780 nm (most common).  
 Laser power: .1-1 mW. typical (at lens).  
 Frequency response: 5 to 20,000 Hz +/- 3 dB.  
 Harmonic distortion: .008 % at 1 KHz.  
 Dynamic range: Greater than 90 dB.  
 Signal to noise ratio: Greater than 85 dB.  
 Wow and flutter: below measurable limit (as good as crystal).

IR detector circuit: -----

This IR Detector may be used for testing of IR remote controls, CD player laserdiodes, and other low level near IR emitters.

Component values are not critical. Purchase photodiode sensitive to near IR - 750-900 um or salvage from optocoupler or photosensor. Dead computer mice, not the furry kind, usually contain IR sensitive photodiodes. For convenience, use a 9V battery for power. Even a weak one will work fine. Construct so that LED does not illuminate the photodiode!

The detected signal may be monitored across the transistor with an oscilloscope.

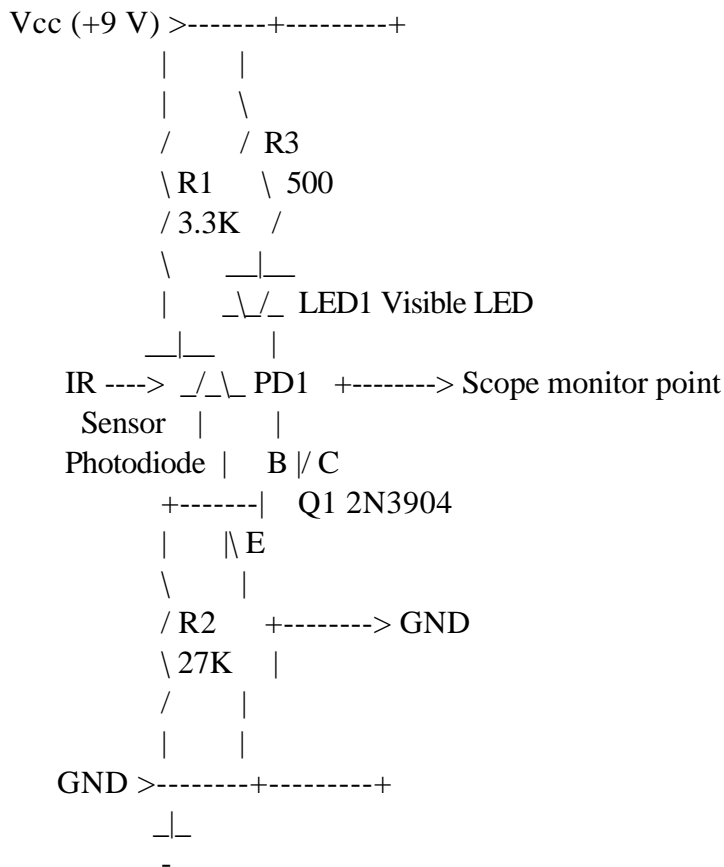



Laserdiode fundamentals: -----

Typical CD laser optics put out about .1-1 mW at the objective lens though the diodes themselves may be capable of up to 4 or 5 mW depending on type. The laserdiodes for CD players are infra red - IR - usually at around 780 nm. Visible laserdiodes are also readily available from many sources. The most common wavelength is 670 nm which is deep red but 630 nm diodes are also available - red orange and appear much brighter (and more expensive at the present time). Inexpensive (well relatively) laser pointers use visible laserdiodes with power outputs up to about 5 mW. This is enough power to risk permanent retinal damage if you look into the beam especially when well collimated as is required for a pointer. Don't.

Typical currents are in the 30-100 mA range at 1.7-2.5 V. However, the power curve is extremely non-linear. There is a lasing threshold below which there will be no output. For a diode rated at a threshold of 80 mA, the maximum operating current may be as low as 85 mA. This is one reason why all actual applications of laserdiodes include optical sensing (there is a built in photodiode in the same case as the laser emitter) to regulate beam power. You can easily destroy a laserdiode by exceeding the safe current even for an instant. It is critical to the life of the laserdiode that under no circumstances do you exceed the safe current limit even for a microsecond!

Laser diodes are also extremely sensitive to electrostatic discharge, so use appropriate precautions. Also, do not try to test them with a VOM which could on the low ohms scale exceed their safe current rating.

While only a few hundred mA at most is dissipated by the laserdiode, a good heat sink is also important for long life and stability. The optical pickup is usually a metal casting partially for this reason. Remember that the active diode chip is only about .1 mm on a side.

It is possible to drive laserdiodes with a DC supply and resistor, but unless you know the precise value needed, you can easily exceed the ratings.

One approach that works for testing is to use a 0-10 VDC supply (preferably a linear supply - a switching supply may put out laserdiode destroying pulses) with say, a 100 ohm resistor in series with the diode. Slowly bring the current up until you get a beam. Use an IR detector for this! If you get the polarity backwards or are actually measuring across the internal photodiode, the voltage across the diode will go above 3 volts or will be less than 1 V. Then, turn power off and reverse the leads. Note: some laserdiodes will be destroyed by reverse voltage greater than 3 V - a spec sheet will list the reverse voltage rating. The ones I have tried out of CD players were fine to at least 5 V in the reverse direction.

Without a laser power meter, however, you will have no way of knowing when the limit on safe beam power (safe for the laserdiode, that is) is reached. If you have the data sheet for your laserdiode, then the best you can do is limit the current to specified maximum rating. Also, there

is usually a weakly visible emission which appears red (for IR laserdiodes) present when powered. Do not be fooled into thinking that the laserdiode is weak as a result of this dim red light. The main beam is IR and invisible - and up to 10,000 times more intense than it appears.

The beam from the raw laserdiode is emitted in a broad wedge typically 10 x 30 degrees. A convex lens is needed to collimate the beam (make it parallel). For optimal results, this needs to be anamorphic - unequal horizontal and vertical focal lengths - to correct the astigmatism of the beam. The mass produced optical pickups used in CD players include this as well as other sophisticated optics.

For an actual application, you should use the optical feedback to regulate beam power. This usually takes the form of a simple current controlled power supply with extensive capacitive filtering and a regulated reference. It is possible to modulate the beam power by tapping into the feedback circuits - as long as you guarantee that the maximum current specification will never be exceeded. Laser diodes do not behave like LEDs and cannot be pulsed for higher peak power - they turn into DEDs - Dark Emitting Diodes.

CW Laser Light (reverse engineered from commercial unit).

-----

This circuit was traced from a commercial CW laser light. Errors may have been made in the transcription. The type and specifications for the laserdiode assembly (LD and PD) are unknown. The available output power is unknown but the circuit should be suitable for the typical 3-5 mW visible or IR laserdiode (assuming the same polarity of LD and PD or with suitable modifications for different polarity units.)

If you do build this or any other circuit for driving a laserdiode, I suggest testing it first with an LED and discrete photodiode to verify current limited operation. Then with the laserdiode in place, start with a low voltage supply rather than 9V until you have determined optimal settings and work up gradually. Laserdiodes are very unforgiving.

Note the heavy capacitive filtering. Changes would be needed to enable this circuit to be modulated at any reasonable rate.

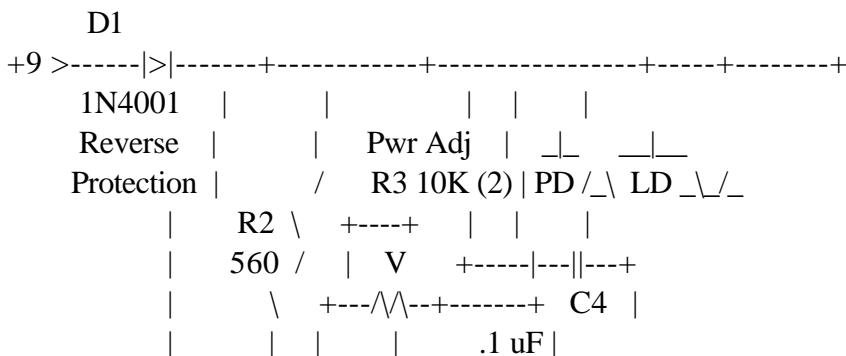

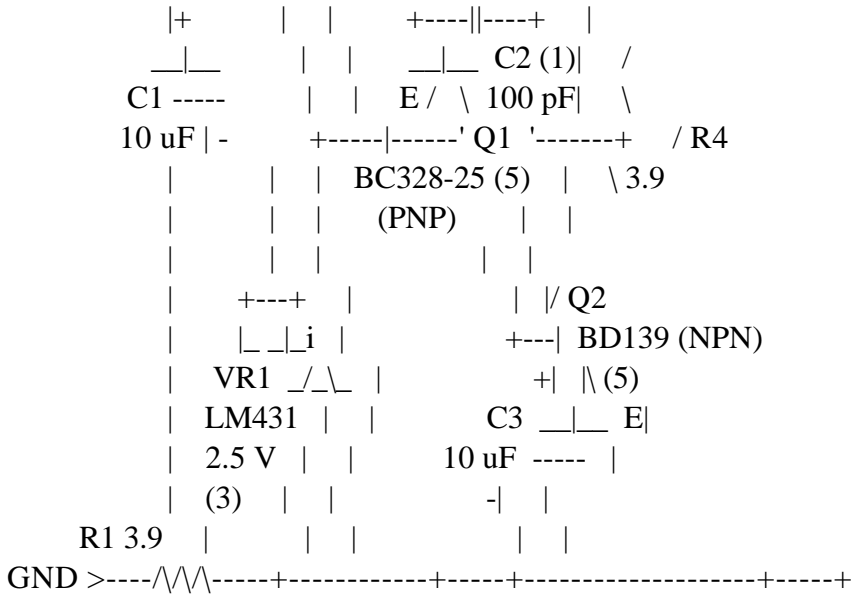

Notes:

1. Capacitor C4 value estimated.
2. Potentiometer R3 measured at 6K.
3. LM431 shunt regulator set up as 2.5 V zener.
4. Supply current measured at 150 mA (includes power on LED not shown).
5. Transistor types do not appear to be critical.

\*\*\*\*\* SERVICE INFORMATION \*\*\*\*\*

Advanced CD troubleshooting: -----

If the solutions to your problems have not been covered in this document, you still have some options other than surrendering your CD player to the local service center or the dumpster.

When tackling electronic faults, a service manual with schematics will prove essential. Many manufacturers will happily supply this for a modest cost - \$10 to \$50 typical. However, some manufacturers are not providing schematics - only mechanical and alignment info. Confirm that a schematic (not just a block diagram) is included if you need one before purchasing the manual.

Howard Sams publishes Sams Photofacts service data for almost every model TV that has ever been sold but their selection of CDfacts is nearly if not totally nonexistent.

Test point locations, important signals, and power supply voltages are often clearly labeled on the electronics board. In this case, quite a bit of troubleshooting can be done without the schematic. There is a good chance that the problem can be isolated to a particular subsystem by just following the signals using this information.

Whatever the ultimate outcome, you will have learned a great deal. Have fun - don't think of this

as a chore. Electronic troubleshooting represents a detective's challenge of the type that Sherlock Holmes could not have resisted. You at least have the advantage that the electronics do not lie or attempt to deceive you (though you may beg to differ at times). So, what are you waiting for?

Suggested references: -----

There are a variety of books dealing with all aspects of CD player repair. While not as common as books on VCR repair, there are more of these than you might think. Your local public library may have some in the electronics section - around 621.38 if your library is numbered that way. Technical bookstores, electronics distributors, and the mail order parts sources listed in this document carry a variety of these texts.

Troubleshooting and Repairing Compact Disc Players Homer L. Davidson TAB Books, A Division of McGraw Hill, Inc. Blue Ridge Summit, PA 17294, USA

(The above book also includes several complete CD player schematic diagrams which are quite interesting in their own right.)

Compact Disc Troubleshooting and Repair Neil Heller and Thomas Bentz Howard W. Sams & Company, A Division of Macmillan, Inc. 4300 West 62nd Street Indianapolis, Indiana 46268, USA

Rubber belts in CD players: -----

The type of belts used in CD players for drawer loading and sometimes elsewhere is nearly always a type with a square cross section. Obtaining an exact replacement belt may be difficult and not really necessary.

Measure the old belt and select one from a parts supplier like MCM Electronics which is as close as possible - equal or slightly greater thickness and an inside circumference (this is how they are measured) such that it will be tight but not so tight as to slow the motor or cause damage to the bearings. This usually means about 5 to 10 percent less than the old (stretched) belt.

Interchangeability of electronic and mechanical components:  
-----

The question often arises: If I cannot obtain an exact replacement or if I have a CD, VCR, or other equipment carcass gathering dust, can I substitute a part that is not a precise match? Sometimes, this is simply desired to confirm a diagnosis and avoid the risk of ordering an expensive replacement and/or having to wait until it arrives.

For safety related items, the answer is generally NO - an exact replacement part is needed to maintain the specifications within acceptable limits with respect to line isolation, X-ray protection

and to minimize fire hazards. However, these components are rare in CD players.

Although only a few manufacturers produce most of the components in CD players and CDRom drives, don't expect a lot of readily interchangeable parts other than the common electronic ones listed below. In their never ending search for cost reductions and technology improvements, manufacturers are constantly tweaking their designs. More and more circuitry is finding its way into custom VLSI chips. Fortunately, these do not fail too often.

The only parts that are fairly standardized aside from the electronic components are motors. Often, if the motor is physically interchangeable, then it will work as a replacement. Electronic components and entire circuit boards (if identical models and production run) can often be substituted without difficulty though servo alignment will probably be needed due to slight unavoidable differences between apparently identical pickups or electronic components.

For common components, whether a not quite identical substitute will work reliably or at all depends on many factors. Except for the optical pickup, non-custom components in CD players are fairly standard.

Here are some guidelines:

1. Fuses - exact same current rating and at least equal voltage rating. I have often soldered a normal 3AG size fuse onto a smaller blown 20 mm long fuse as a substitute.
2. Resistors, capacitors, inductors, diodes, switches, potentiometers, LEDs, and other common parts - except for those specifically marked as safety-critical - substitution as long as the replacement part fits and specifications should be fine. It is best to use the same type - metal film resistor, for example. But for testing, even this is not a hard and fast rule and a carbon resistor should work just fine.
3. Rectifiers - replacements should have at equal or better PRV and  $I_{max}$  specifications. For power supply rectifiers, 1N400x types can usually be used.
4. Transistors - substitutes will generally work as long as their specifications meet or exceed those of the original. For testing, it is usually ok to use types that do not quite meet all of these as long as the  $BV_{ceo}$  and  $I_c$  specifications are not exceeded. However, performance may not be quite as good. For power types, make sure to use a heatsink.
5. Motors - small PM motors may be substituted if they fit physically. Brushless DC spindle motors are not usually interchangeable.
6. Sensors - many are sufficiently similar to permit substitution.
7. Power transformers - in some cases, these may be sufficiently similar that a substitute will work. However, make sure you test for compatible output voltages to avoid damage to the

regulator(s) and rest of the circuitry.

8. Belts - a close match should be good enough at least to confirm a problem or to use until the replacements arrives.

9. Mechanical parts like screws, flat and split washers, C- and E-clips, and springs - these can often be salvaged from another unit.

10. Optical pickups - see the section below: "Interchangeability of components in the optical pickup".

The following are usually custom parts and substitution of something from your junk box is unlikely to be successful even for testing: microcontrollers, other custom programmed chips, display modules, and entire optical pickups, optical decks, or power supplies unless identical.

#### Interchangeability of components in the optical pickup: -----

Once you have located a problem in the optical pickup, what should you do? For parts like laserdiodes and photodiode arrays, there are probably too many variables to consider and the labor and risks involved - even for the do-it-yourselfer - would likely be unacceptably high. As an example, the laserdiode, which is an expensive component you might be tempted to attempt replacing with one from another pickup (1) may not fit physically, (2) may have different polarity laserdiode and photodiode inside the case, (3) may have a very different threshold current and safe operating current, and (4) may have a different optical alignment with respect to any index marks. Any of these would likely make the interchange virtually impossible. Even replacement with an identical laserdiode would prove challenging without the optical alignment jigs and specialized test equipment.

The only breakdown below the pickup level that I would consider as having a reasonable chance of success would be to swap the lens assembly including focus and tracking coils between identical pickups. The optical alignment is not supercritical at this point. However, optical and servo alignment might be needed after this exchange.

If you have narrowed the problem down to the pickup and you have an identical pickup which you believe to be functional, the best bet is to exchange the entire pickup as a unit. Only minimal servo system alignment would likely be needed after such a replacement. The only optical adjustment needed might be the setting making the beam perpendicular to the disc surface - often a hexagonal nut on the bottom of the deck. The only cautions are to be careful with respect to static discharge which could destroy the laserdiode, take care not to rip any of the fine ribbon or other electrical cables, and avoid damaging the delicate lens assembly. However, you will probably wish you had that friendly unemployed Swiss Watchmaker for your assistant.

Better yet is to replace the entire optical deck as a unit. This is a lot less work and there is no risk of optical alignment problems at all. Then, only servo alignment may be needed.

Recommended parts suppliers: -----

For general electronic components like resistors and capacitors, most electronics distributors will have a sufficient variety at reasonable cost. Even Radio Shack can be considered in a pinch.

However, for consumer electronics equipment repairs, places like Digikey, Allied, and Newark do not have the a variety of Japanese semiconductors like ICs and transistor or any components like flyback transformers or even degauss Posistors.

The following are good sources for consumer electronics replacement parts, especially for VCRs, TVs, and other audio and video equipment:

MCM Electronics (VCR parts, Japanese semiconductors,  
U.S. Voice: 1-800-543-4330. tools, test equipment, audio, consumer  
U.S. Fax: 1-513-434-6959. electronics including microwave oven parts  
and electric range elements, etc.)

Dalbani (Excellent Japanese semiconductor source,  
U.S. Voice: 1-800-325-2264. VCR parts, other consumer electronics,  
U.S. Fax: 1-305-594-6588. Xenon flash tubes, car stereo, CATV).  
Int. Voice: 1-305-716-0947.  
Int. Fax: 1-305-716-9719.

Premium Parts (Very complete VCR parts, some tools, adapter  
U.S. Voice: 1-800-558-9572. cables, other replacement parts.)  
U.S. Fax: 1-800-887-2727.

Computer Component Source (Mostly computer monitor replacement parts,  
U.S. Voice: 1-800-356-1227. also, some electronic components including  
U.S. Fax: 1-800-926-2062. semiconductors.)  
Int. Voice: 1-516-496-8780.  
Int. Fax: 1-516-496-8784.