

# Add a Digital-Frequency Display to Your Equipment

*One of these PIC-based displays can be added to almost any receiver, transmitter, or piece of test equipment.*

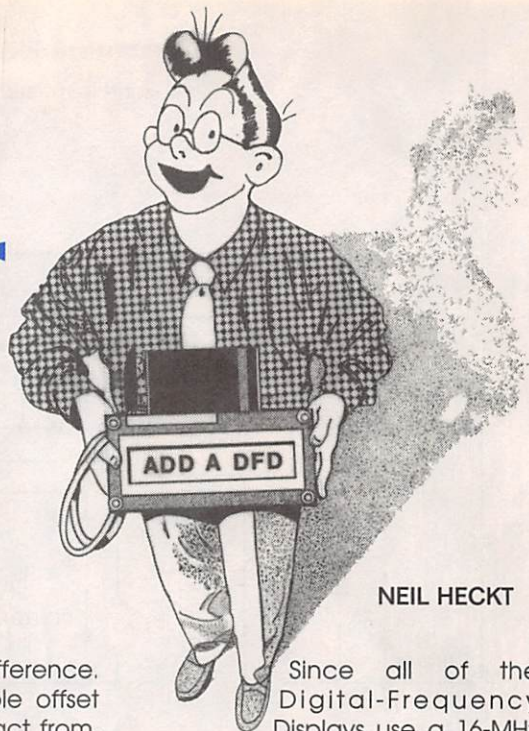

NEIL HECKT

While a frequency counter is a handy piece of test equipment to have when working with a piece of equipment on a bench, having such an item built into a radio, for example, would make a very useful tuning indicator. There are many examples of modern equipment that sport the latest digital display. Some of those displays go way beyond the simple ability of a digital-frequency readout. In fact, some of the features integrated into those displays almost qualify them as full-featured frequency counters in their own right.

It would be wonderful to have one of those state-of-the-art devices; justifying it, on the other hand, can be difficult. If you have a unit that works well with little or no trouble or repairs, why take the risk on a new piece of gear that might end up a "repair-shop queen" all for the want of a few shiny buttons and displays?

The solution, then, is to retrofit a digital display onto your existing equipment. By keeping your existing unit, you don't have to learn the "ins and outs" of a new arrangement of controls. One less piece of otherwise perfectly good piece of equipment stays out of the landfills, and the cost of adding new functionality instead of buying an entire new rig has no comparison—especially where your bank account is concerned!

The Digital-Frequency Displays presented here are miniature fre-

quency counters with a difference. They feature an adjustable offset that can add to, or subtract from, the measured frequency. As such, they can display the RF frequency of superheterodyne receivers and transmitters. If the offset is set to zero, they can be used with direct-conversion receivers or as bench-top frequency counters.

Rather than try to incorporate all of the features that would be necessary to make a universal model, a "family" of displays was created. That helped to keep down the size, cost, and power supply requirements. All versions have the same physical size and shape, as well as many common circuit elements, but differ considerably in application and functionality. Of the four types of displays, only two will be described in detail; the other units are more specialized in their application and although some may find them useful, will be of limited interest.

**Measuring Frequency with A PIC Microcontroller.** All frequency counters work by counting the number of input cycles for a specified period of time. If the time period were one second, the result would be displayed as cycles per second.

A PIC microcontroller has a timer that can be clocked by an external signal. The internal timer is an 8-bit register that can handle a frequency that is no more than one-fourth of the chip's oscillator frequency.

Since all of the Digital-Frequency Displays use a 16-MHz crystal to drive the PIC chip, the timer can only handle up to a 4-MHz signal. Beyond that limit, an internal prescaler can be used to divide down the input frequency so that it is less than the 4-MHz limit. Although the PIC software sets the prescaler to divide by 256, the maximum input frequency that the prescaler can handle is 50 MHz; to go beyond that, an external prescaler will need to be added.

A disadvantage of the prescaler circuit in this application is that the software cannot read its value. Fortunately, we can "trick" the prescaler into revealing its contents. After the measurement period is over, the software increments the prescaler until it overflows, increasing the counter register; some external hardware is needed and will be discussed later. By counting the number of times needed to make that happen, we can easily figure out what its value was at the end of the measurement period. Actually, the Digital-Frequency Displays use a 24-bit counting scheme rather than the 16-bit system formed by the 8-bit counter and 8-bit prescaler. The additional 8 bits is a PIC register that is incremented every time that the counter register overflows.

The measurement period is set by a software loop that is designed



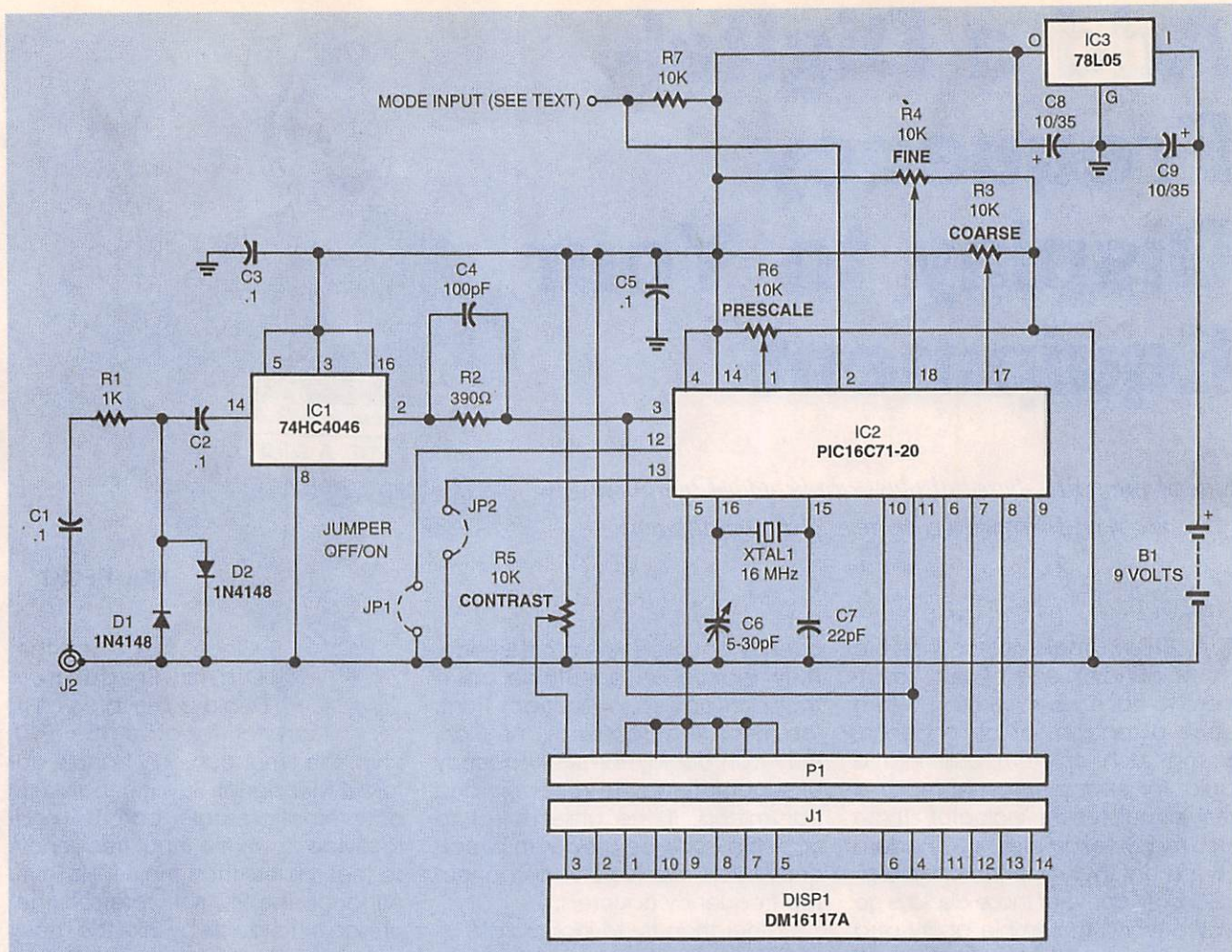

Fig. 1. A digital-frequency display such as the DFD1 shown here can be easily added to an existing piece of gear. By using a portion of IC1's phase-detection circuitry, frequencies up to 45 MHz can be displayed.

to execute an exact number of CPU cycles. While the vast majority of instructions in a PIC microcontroller are executed in one cycle, there are some two-cycle instructions such as conditional jumps that must be taken into account.

Most frequency counters have a "flicker" in the displayed value due to round-off error. That is caused by the fact that the input frequency is usually not an exact whole number. For example, let's measure a 10.6-Hz signal with a sample period of one second and a resolution of 1 Hz. The display will be 11 for 60% of the time and 10 for 40% of the time. The resulting display will then flicker between 10 and 11. A more annoying situation is with a frequency of 99.6 Hz. In that case, the display would flicker between 99 and 100. All of the Digital-Frequency Displays (with one exception) use a digital-filtering

algorithm in their software to eliminate that type of flicker. In general, the technique consists of doubling the sample period, subtracting the current count from the previous count, and only changing the display if the count change is greater than one. The penalty is that the display is updated at only half the rate that would normally occur. For a frequency resolution of 10 Hz, the update rate is approximately 5 times per second—close enough to real time. In that case, the counter has 5-Hz resolution but only displays changes of 10 Hz or more.

**A Low-End Display.** The first version that we'll describe is called the DFD1; its schematic diagram is shown in Fig. 1. The DFD1 is intended for single-conversion superheterodyne receivers and transmitters. By setting an offset value into the unit

the carrier wave can be read out by measuring the IF frequency. With the offset value set to zero the DFD1 can be used with direct-conversion radios or as a bench-top frequency counter usable to 45 MHz.

A signal applied to J2 is conditioned by IC1, a 4046 phase-locked loop chip. The presence of the 4046 might appear strange in a frequency-counting circuit, but it is always fun to use a chip for something other than its original purpose! The 4046 contains an input amplifier on pin 14 that converts a low-level RF signal to CMOS voltage levels. The amplifier is connected to each of the three on-board phase detectors. One of those phase detectors is an EXCLUSIVE-OR gate. If the gate's other input (pin 3) is held at logic high, the output is a CMOS level squarewave. Since the oscillator is not used, pin 5 is held high so that



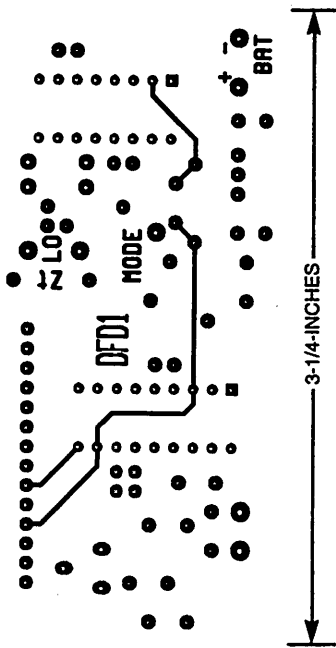

Here's the foil pattern for the component side of the DFD1. Since it is double-sided, you will need to provide some way to connect the traces on both sides of the board.

any possible interference is eliminated; power consumption is also reduced. With the addition of coupling capacitor C2 on the input and decoupling capacitor C3 on the power supply, the 4046 does an excellent job of amplifying and squaring RF signals up to 45 MHz.

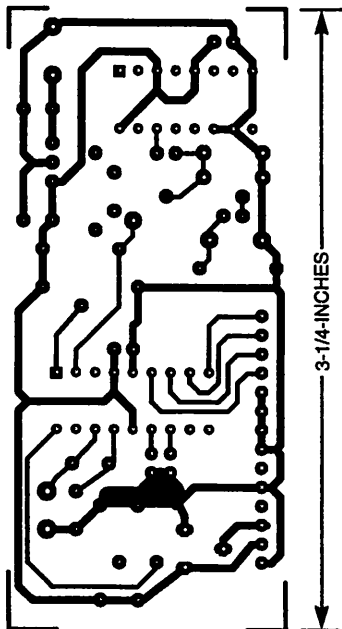

Here's the foil pattern for the solder side of the DFD1.

The input is protected from transients with R1, D1, and D2. The output of IC1 is fed to the counter input (pin 3) of IC2 through R2. Note that that pin on IC2 is also connected to DISP1 and pin 11 of IC2; more on that later.

As mentioned above, the Digital-Frequency Display can add or subtract an offset value from the read frequency. Both coarse and fine offset inputs are used. The actual controls are 15-turn trimpots that are wired as voltage dividers. When IC2's analog-digital converters digitize the voltage, the trimpots act like 128-position switches. In the DFD1, R3 and R4 create a 14-bit offset that is multiplied by a constant and used as the offset. The advantages of using trimpots are low cost, ease of adjustment, high resolution, and the ability to remember their settings without power.

An additional prescale input is set by R6. That input is meant to compensate for any external prescalers that might be between the signal and the DFD1. The software reads R6 as a value between 1 and 256 and multiplies it by the frequency value. Keep in mind that that prescale adjustment is done completely in software after measuring the frequency of the input signal; it is not connected with the prescale register in IC2's hardware. An example of the use of the prescale adjustment will be given later in this article.

A fourth analog input has no control connected to it; it is labeled "mode" on the schematic diagram. The mode input is not necessary for using the DFD1; it is provided simply for displaying a series of abbreviations on the display to indicate what type of signal is being measured. The particular abbreviation is selected by connecting a resistor between the mode input and ground. One example of its use would be in a radio that has a mode switch. By selecting a series of resistors that can be grounded by that switch, the DFD1 can indicate what mode the radio is in. The different mode abbreviations that can be displayed are shown in Table 1 along with the resistor value needed to activate them. If you do not need

## PARTS LISTS FOR THE DFD1

### SEMICONDUCTORS

- IC1—74HC4046 phase-locked loop, integrated circuit
- IC2—PIC16C71-20 microcontroller, integrated circuit
- IC3—78L05 5-volt regulator, integrated circuit
- D1, D2—1N4148 silicon diode

### Resistors

- (All resistors are 1/4-watt, 5% units unless otherwise noted.)
- R1—1000-ohm
  - R2—390-ohm
  - R3, R4, R6—10,000-ohm potentiometer, PC-mount, 15-turn
  - R5—10,000-ohm potentiometer, PC-mount, single-turn
  - R7—10,000-ohm

### CAPACITORS

- C1—C3, C5—0.1- $\mu$ F, ceramic-disc
- C4—100-pF, ceramic-disc
- C6—5-30-pF, ceramic trimmer
- C7—22-pF, ceramic-disc
- C8, C9—10- $\mu$ F, 35-WVDC, electrolytic

### ADDITIONAL PARTS AND MATERIALS

- B1—9-volt battery
- DISP1—16-character liquid-crystal display, Optrex DM16117A or similar
- J1—14-pin single in-line connector, PC mount
- J2—BNC or other suitable connector
- JP1, JP2—2-pin jumper post
- P1—14-pin single in-line square-post header, PC mount
- XTAL1—16-MHz crystal
- Jumper blocks, wire, hardware, etc.

that feature, simply leave the input unconnected, and no mode abbreviation will appear on the display.

An "intelligent" liquid-crystal display (LCD) is used for DISP1. The unit specified for the Digital-Frequency Displays is available as either a standard unit or one with a backlight for use in low-light conditions. Additional circuitry will be needed for the backlight option, which is beyond the scope of this article. If you are interested in such an option, you should follow the information provided in the manufac-



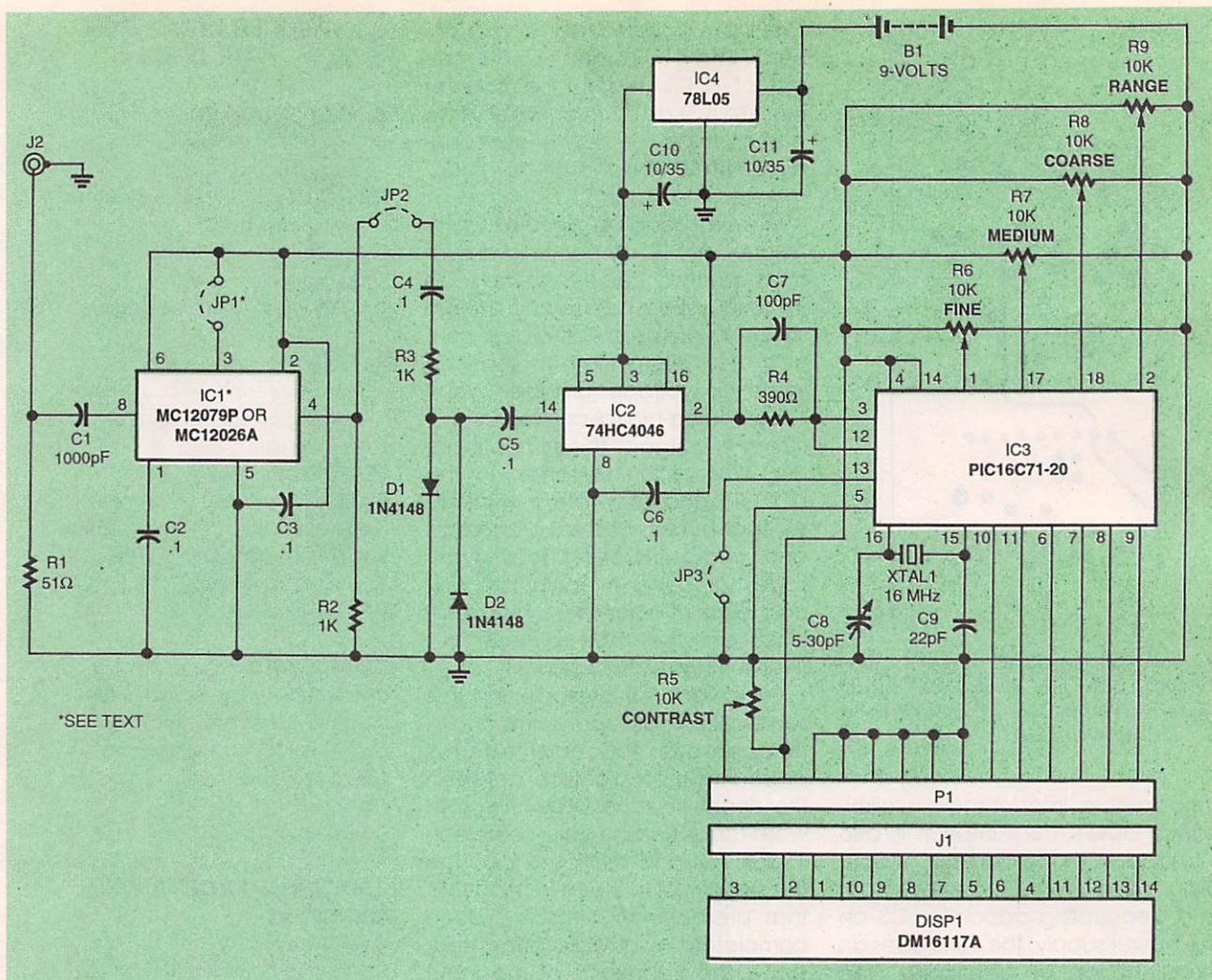

Fig. 2. Like the DFD1, the DFD4 can be used in equipment such as frequency generators and radios; it can also be used as a stand-alone unit. With the addition of a prescaler on the input, frequencies up to 3 GHz can be handled.

turer's data sheet for the display module. Such displays are called "intelligent" because they appear to a microcomputer system as just another set of storage registers. The characters to be displayed are simply loaded into the display unit, and its on-board circuitry handles the complexities of controlling a liquid-crystal display panel. These devices can be operated either with an 8-bit or a 4-bit interface. The 4-bit mode is used with the Digital-Frequency Displays to limit the number of pins needed to connect the microcontroller to the LCD unit.

The LCDs are also bi-directional; that is, you can read data from the unit as well as write data to it. To keep the number of pins needed for the interface down, the Digital-Frequency Displays never read from the LCD; the read/write con-

trol line is grounded to keep the LCD in write mode all of the time. Usually, you would read the status register of the LCD to see if it is busy before writing new display data or a command. The Digital-Frequency Displays simply wait an appropriate amount of time before writing to the LCD again, giving it time to "digest" the previous information that was sent to it. The number of interface pins needed is six: four data lines and two control lines.

There are two versions of 16-character-by-1-line LCDs available on the market; they are not software compatible. The first type stores the 16 characters as a single row; that is, the characters are stored in 16 contiguous memory locations that can be accessed completely at random. That type of display has two ICs on it. The sec-

ond type, with only one chip on the back, is logically organized as two lines of eight characters. Even though the display looks like a single line of 16 characters, the memory is set up as two separate halves. To access the display data, you must first send a command selecting which "row" you want to write to. It is that second type of LCD that is used here.

We noted before that pin 3 of IC2 is connected to R2, pin 11 of IC1, and DISP1. While the main use of pin 11 of IC2 is as a register-select control for DISP1, it can be set as either an output line or an input line. When IC2 is counting the input frequency from IC1, pin 11 is set as a high-impedance input; IC1 can then pass the frequency signal through R2 to pin 3 of IC2, incrementing the prescaler and counter



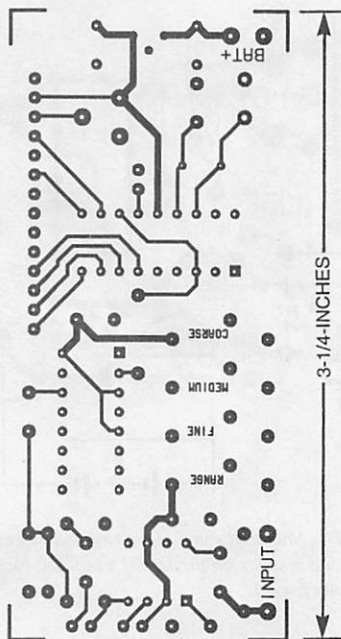

Here's the foil pattern for the component side of the DFD4. While the two versions of the DFD are based on similar circuitry, the layouts are very different. Check that you have the correct patterns before etching your own board.

registers. When the measurement period is over, pin 11 on IC2 is set to be an output, clamping pin 3 of IC2. The result is that IC2's counter no longer sees any pulses, freezing the count. By toggling pin 11, the prescaler is incremented until it

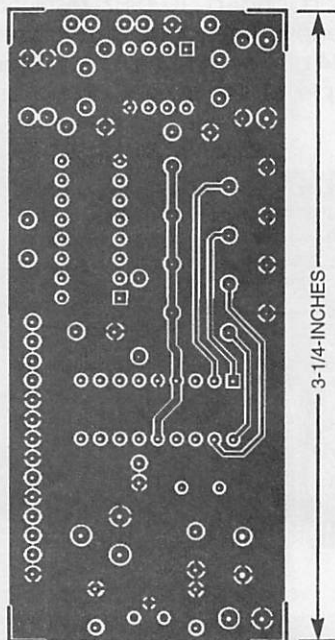

Here's the foil pattern for the solder side of the DFD4.

## PARTS LISTS FOR THE DFD4

### SEMICONDUCTORS

- IC1—MC12079P or MC12026A prescaler, integrated circuit (see text)  
 IC2—74HC4046 phase-locked loop, integrated circuit  
 IC3—PIC16C71-20 microcontroller, integrated circuit  
 IC4—78L05 5-volt regulator, integrated circuit  
 D1, D2—1N4148 silicon diode

### RESISTORS

- (All resistors are 1/4-watt, 5% units unless otherwise noted.)  
 R1—51-ohm  
 R2, R3—1000-ohm  
 R4—390-ohm  
 R5—10,000-ohm potentiometer, PC-mount, single-turn  
 R6—R9—10,000-ohm potentiometer, PC-mount, 15-turn

### CAPACITORS

- C1—1000-pF, ceramic-disc  
 C2—C6—0.1- $\mu$ F, ceramic-disc  
 C7—100-pF, ceramic-disc  
 C8—5-30-pF, ceramic trimmer  
 C9—22-pF, ceramic-disc  
 C10, C11—10- $\mu$ F, 35-WVDC, electrolytic

### ADDITIONAL PARTS AND MATERIALS

- B1—9-volt battery  
 DISP1—16-character liquid-crystal display, Optrex DM16117A or similar

- J1—14-pin single in-line connector, PC mount  
 J2—BNC or other suitable connector  
 JP1—JP3—2-pin jumper post  
 P1—14-pin single in-line square-post header, PC mount  
 XTAL1—16-MHz crystal  
 Jumper blocks, wire, hardware, etc.

Note: The following items are available from: Almost All Digital Electronics, 1412 Elm St. SE, Auburn, WA 98092; Tel: 253-351-9316 (9 AM to 9 PM Pacific time); Fax: 253-931-1940; E-mail: neil@aade.com; Web: www.aade.com. Complete kit of all parts for DFD1 including etched PC board, DISP1, programmed PIC controller, and all electronic components, \$49.95; Complete kit of parts for DFD4 including etched PC board, DISP1, programmed PIC controller, and all electronic components, \$59.95; Partial kit consisting of etched PC board, XTAL1, and programmed PIC controller, \$29.95 for either version; Aluminum enclosure with black plastic bezel, \$15.95; PC board alone for either unit, \$4.00. To upgrade DISP1 to a backlit unit on any complete kit, please add \$10.00. Please add \$1.50 for shipping and handling. WA residents must add appropriate sales tax. Copies of the instruction manual for any version DFD is available by sending a self-addressed No. 10 envelope with two stamps postage to the above address.

overflows into the counter register; that is how the prescaler register is read as discussed before. Having C4 in parallel with R2 provides frequency compensation.

Note that all of that activity on DISP1's register-select line has no effect on the display; all data and control lines are ignored unless DISP1's enable line is activated by pin 10 of IC2. To round out the discussion of the circuitry surrounding DISP1, the contrast of the display is adjusted by R5.

Jumpers JP1 and JP2 set two additional options for the DFD1. The first one selects whether the display will have a 10-Hz or 100-Hz resolution; if a jumper is installed, shorting the connection, a 100-Hz resolution will be in effect. The second jumper

selects whether to add (no jumper) or subtract (jumper installed) the offset value from the frequency.

Some might be wondering why someone would "cripple" a high-performance unit such as the DFD1 by forcing it down to a 100-Hz resolution. The reason for that has to do with the variable-frequency oscillators (VFOs) of some older radios. Those older circuits many times do not have sufficient short-term stability. With a 10-Hz resolution on the DFD1, the last digit might change continuously. If that happens, the 100-Hz option gives a more stable display.

The DFD1 regulates and filters the power supply voltage with IC3, C8, and C9. Although a 9-volt battery is shown for B1, any source of filtered DC can be used to power the

DFD1. For example, a convenient power source in the equipment in which you will be mounting the DFD1 can be used as long as it is a filtered DC source between 8 and 18 volts.

**A High-End Display.** The other Digital-Frequency Display that will be discussed is called the DFD4; its schematic diagram is shown in Fig. 2. If you compare the schematic diagrams of the DFD4 to the DFD1, you'll see that the two units are very similar. The main difference is the addition of prescaler chip IC1. With the use of IC1, the DFD4 can be used in UHF applications that need to read frequencies up to 3 GHz. Although IC1's specification sheet only guarantees operation up to 2.8 GHz, the manufacturer claims that 3-GHz operation and higher is easily achieved. However, be advised that operation at those frequencies might become a bit difficult. Careful connection of the input frequency with suitable coaxial cable becomes mandatory for proper operation.

Although IC1 sports a programmable divide-ratio feature, it is permanently set to divide by 128 in the DFD4 circuit. Also keep in mind that a socket is not recommended for frequencies above 1 GHz. However, testing of the author's prototype yielded very reliable operation when using a socket at frequencies up to 540 MHz—the limit of the available test equipment.

If you do not need the full 3-GHz capability of the DFD4, IC1 can be substituted with an alternate prescaler mentioned in the Parts List. The circuit will then be limited to 400 MHz—perfectly suitable for VHF applications. When using the lower-frequency prescaler, JP1 will need to be installed. The substitute prescaler, with its higher dividing ratio, allows for resolutions of 10 Hz up to 32-MHz frequencies and 100 Hz at higher frequencies; the display will be updated at near real-time rates. It also allows the inclusion of digital filtering to eliminate round-off flicker—a feature that cannot be used in the full-blown 3-GHz model.

Jumper JP2 is used to connect the output of IC1 to the input of

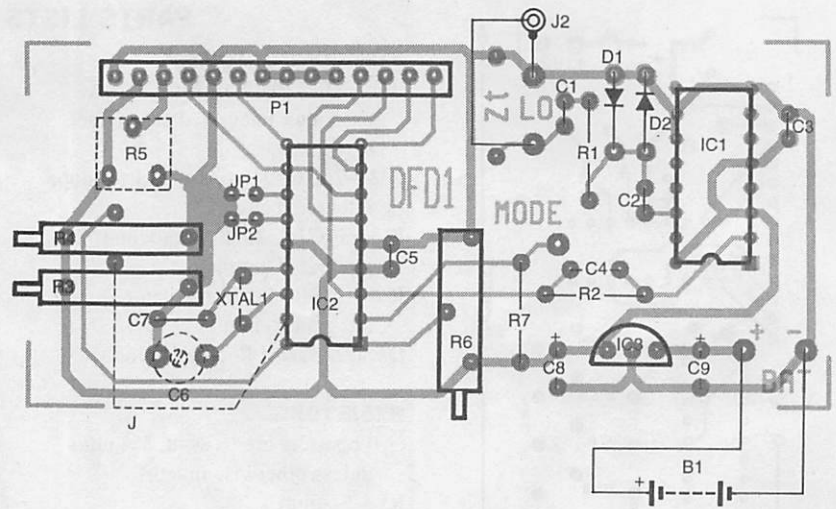

Fig. 3. Here's the parts-placement diagram for the DFD1. Note that some of the components mount on the solder side of the board. If you need to have a load resistor on the DFD1's input, a location has been provided just to the left of the input connections from J2.

IC2. Normally, the two circuits would be connected; without the connection, no input can get to IC3 or the input would be applied to IC2, making the DFD4 a copy of the DFD1. The purpose of JP2 is to provide just that type of access to the input of IC2. That would be done when using the DFD4 as a bench-top frequency counter; more on how to do that later.

Whereas the DFD1 used two trim-pots for setting the offset value, the DFD4 uses three—R1, R2, and R3. The result is a 21-bit number. That number is multiplied by 1000 (1 kHz) for an offset range from 0 to 2,097,152,000 Hz. Like the DFD1, the DFD4's offset can be added to or

subtracted from the measured frequency by setting JP3.

A fourth analog input provided by R4 sets the DFD4 to one of four operating ranges: the "HF SLOW" range from 0-32 MHz with a 1-second sample period and a 1-Hz resolution; the "HF FAST" range from 0-32 MHz with a 0.1-second sample period and a 10-Hz resolution; the "UHF SLOW" range from 10-3000 MHz with a 1.28-second sample period and a 100-Hz resolution; and the "UHF FAST" range from 10-3000 MHz with a 0.128-second sample period and a 1000-Hz resolution. Whenever the range changes, the DFD4 displays the new range for a couple of seconds; that makes it

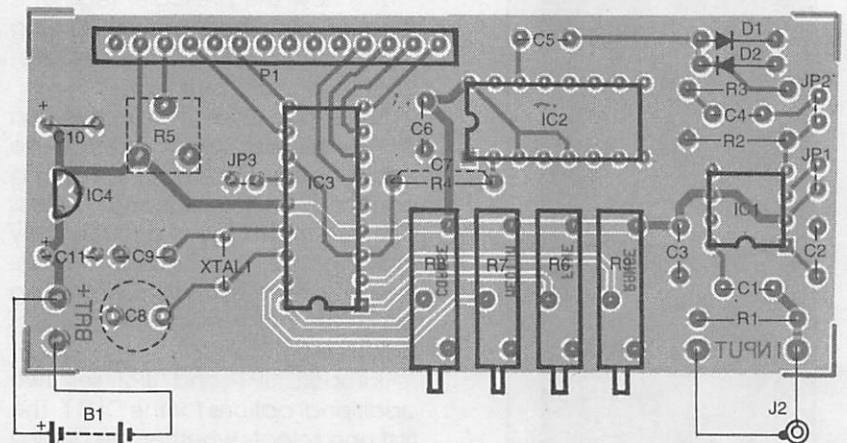

Fig. 4. The DFD4 is similar in construction to the DFD1. Again, note that some of the components mount on the solder side of the board. Those parts need to be accessible for settings and adjustments with DISP1 in place.



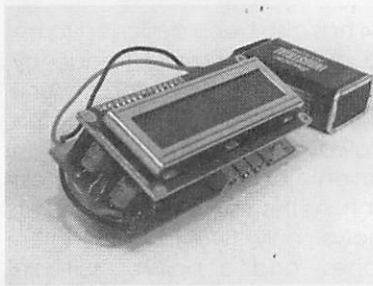

Fig. 5. The completed DFD4 is a compact unit. Note how the PC board "piggybacks" onto DISP1.

easy to set the range with a trim-pot.

**Construction.** Because of the high frequencies involved, the Digital-Frequency Displays should be built on a PC board. Double-sided boards are used for a compact unit; foil patterns have been included for both versions. If you are going to etch your own board, you should be sure to solder connections on both sides of the board. Boards that are purchased from the source given in the Parts List have plated-through holes.

The parts-placement diagram for the DFD1 is shown in Fig. 3; follow Fig. 4 if you are building the DFD4. Since both units are very similar, construction details apply to both units.

Note that some components mount on the solder side of the board. Those parts will need to be

accessed with the unit assembled. Items such as the jumper blocks and DISP1's contrast control would otherwise be inaccessible once DISP1 is mounted in place.

Start by mounting XTAL1. It should be mounted off of the board so that its metal can does not touch the traces on the topside of the board. Use either a flat toothpick or a piece of insulated wire to space the crystal off of the board while soldering it. Once soldered, remove the spacer; an easy task to perform as XTAL1 is the only component on the board!

The microcontrollers will need to be programmed before installing them. Download the appropriate code from the Gernsback FTP site ([ftp.gernsback.com/pub/EN](http://ftp.gernsback.com/pub/EN)). The names of the files are *dfd1.hex* and *dfd4.hex* for each version, respectively. When programming the PIC, note that your programmer should be set to program the PIC for an HS-XTAL oscillator, the Watchdog Timer disabled, and the Power-Up Timer enabled.

Continue by mounting the rest of the topside components, starting with the smallest physical packages such as the resistors and diodes. Sockets can be used for the ICs, with the exception of the 3-GHz version of IC1 on the DFD4 as discussed before. Note that on the DFD4, C7 will be tack-soldered on

the bottom side of the board after R7 is installed so that both components are wired in parallel. Alternatively, wrap the leads of C7 around R4's leads and solder all joints after installing the R4/C7 combination in the board.

Once all of the topside components have been mounted, continue with the bottom-side components; all of their connections are accessible from the topside of the board. Finally, the DFD1 needs a jumper wire tack-soldered to the indicated points. Mounting J1 onto DISP1 completes assembly. With J1 mated to P1, the completed Digital-Frequency Display forms a compact package. After checking your workmanship for defective solder joints or incorrect component placement, look it over again. Better yet, set it aside for a while and re-inspect it after you've had a bit of a rest. Many seemingly obvious mistakes can be easily overlooked if you are constantly staring at them.

A completed DFD4 is shown in Fig. 5. It is now ready for installation in the equipment of your choice.

**Installing the DFD.** Obviously we can't give detailed installation instructions for each and every possible piece of equipment, so some general recommendations will have to suffice.

For starters, a suitable hole will have to be cut in the unit's case to hold the Digital-Frequency Display. Detach DISP1 from the unit and mount it to your equipment. Once mounted, it is easy to plug P1 into J1 once the Digital-Frequency Display is wired up to power and signal inputs.

If you are mounting the DFD in a radio, for example, the input at J2 (which can be eliminated in favor of a direct connection) is connected to the variable-frequency oscillator (VFO) of the radio. That connection should be made at a low-impedance point, such as the unbypassed cathode of a vacuum-tube oscillator or the unbypassed emitter of a transistor oscillator; use the schematic diagram of your radio to pinpoint that location. It should also be isolated from the tank circuit of the oscillator to

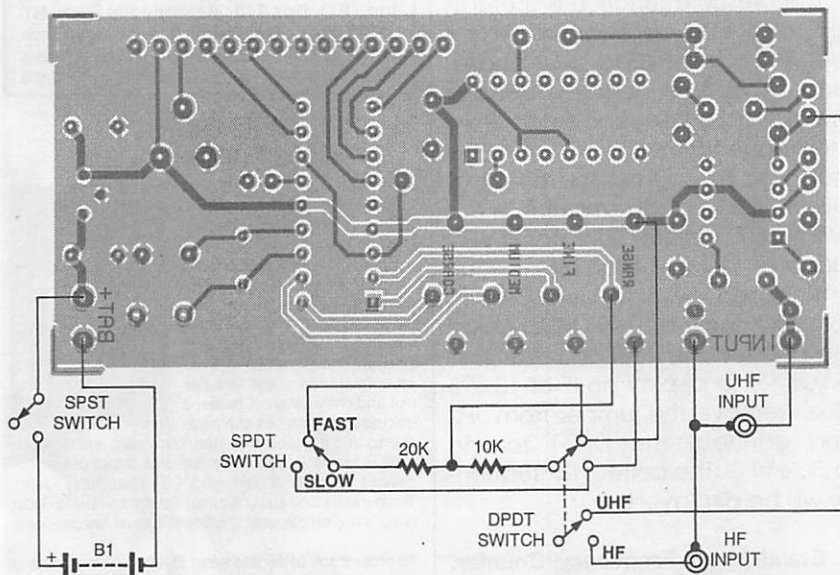

Fig. 6. By replacing R9 with this simple circuit, the DFD4 can be used as a stand-alone frequency counter capable of 3 GHz. Battery power means that the unit is portable and easy to use in the field.

prevent the input capacitance of the DFD from affecting the frequency of the oscillator. If an amplifier exists between the oscillator and the mixer, the connection should be made at the output of the amplifier. In general, the best point is at the input to the mixer.

Because of the amplitude-limiting effect of D1 and D2, the level of the voltage should be scaled to prevent clipping the waveform. Using a potentiometer as a "volume control" between the signal and ground can do that. The signal should be capacitor-coupled to one side of the potentiometer with the other side connected to ground. The wiper is connected to the DFD's input. The value of the coupling capacitor should be about 100 pF for frequencies above 10 MHz and 1000 pF for frequencies below 10 MHz. The value of the potentiometer should be about 1000 ohms. Adjust the potentiometer to the minimum signal level that provides reliable operation at the highest frequency that might exist at that point.

**Setting Up a DFD.** Setting up a Digital-Frequency Display is simple. We'll discuss the DFD1; the DFD4 works in a similar manner. Start by shorting the input to ground; that will prevent noise from triggering the unit. Adjust R6 (prescale) to display a minimum frequency. Next, adjust R3 (coarse) and R4 (fine) to display the desired offset. If you are going to be working with a radio receiver or transmitter, the offset is usually the radio's IF frequency. If the prescale option is to be used, first set the coarse and fine offsets to the IF frequency divided by the prescale to be used, then adjust

the prescale control (R6) until the display reads the IF frequency. That way, we can be sure that the prescale setting is properly set. All of the trimpot adjustments should be left half way between the lower and upper transition points for best thermal stability.

Connect the DFD1 to the VFO of a radio. The display will show the VFO frequency with the offset either added to or subtracted from it; JP2 controls the function. By setting JP2, the DFD1 will display the correct RF frequency regardless of the relationship between the VFO, IF, and RF.

If you have a band-imaging radio, that feature can be very helpful. By connecting JP2 to the band-select switch, the DFD1 can show the correct display for both bands. If your band-imaging radio is set for the 17- and 30-meter bands with a VFO frequency range of 14 to 14.168 MHz and an IF of 4 MHz, the readout frequencies will be 18 to 18.168 MHz (JP2 off) or 10 to 10.168 MHz (JP2 on).

For the 80- and 20-meter bands with a VFO range from 5.0 to 5.5 MHz and an IF of 9 MHz, the readout frequencies will be 14.0 to 14.5 MHz and 4.0 to 3.5 MHz. In the latter case, the VFO tunes backward. Mathematically, VFO - OFFSET will be a negative number but the DFD1 is designed to display the absolute value.

The prescale function is useful in VHF and UHF applications where the VFO is generated by a phase-locked loop that includes prescaler dividers, or by frequency multipliers. The frequency of the VFO can be multiplied to counter the effect of the divider. A good example is the SWAN 250 six-meter rig. It has a VFO range of 13.1 to 14.433 MHz, which is multiplied by 3 to yield 39.3 to 43.3 MHz. The IF is 10.698 MHz. Adjust the DFD1 to the IF/3, or 3.566 MHz. Adjust R6 to display an IF of 10.698 MHz. Remove the jumper from JP2 and connect the DFD1 to the radio's VFO. The correct RF frequency will be displayed.

**A Stand-Alone Frequency Counter.** As versatile as the Digital-Frequency Displays are when added to an existing piece of equipment, the

DFD4 has also been designed to be used as a stand-alone frequency counter. Such a high-capacity unit with its ability to work into the microwave spectrum will make an excellent addition to any test bench. As the wiring diagram in Fig. 6 shows, only two resistors, three switches, and a pair of suitable input jacks are needed. Note how a switched-resistor circuit has replaced R9. Feel free to use any style of connectors that will make the stand-alone version of the DFD4 easy to connect to other equipment.

The Digital-Frequency Displays make it easy and inexpensive to add a digital-frequency readout to almost any kind of radio or test equipment, or make an inexpensive bench-top frequency counter. No longer will guesswork need to guide you in your radio work—a simple glance at the display is all that's needed!  $\Omega$

**THE TRANSDUCER PROJECT BOOK**



**THE TRANSDUCER PROJECT BOOK**  
MICHAEL J. FREEMAN

**1992T**—From TAB Books. A unique collection of practical transducer devices that you can put together simply and inexpensively. You can build a seismic sensor, a temperature survey meter, an open-door annunciator, a moisture detector, an automatic night light, and more. To order—ask for book **1992T**, and include your check for **\$6.99 - clearance (includes s&h)** in the US and Canada, and order from —**Electronic Technology Today Inc., P.O. Box 240, Massapequa Park, NY 11762-0240**. US funds only; use US bank check or International money order. Allow 6-8 weeks for delivery. MA06

### ELECTRONIC SECURITY DEVICES

A great book for project builders. It is quite common to associate the term "Security Devices" with burglar alarms of various types. However in fact it can refer to any piece of equipment that helps to protect people or property. The text is divided into three basic sections: Chapter 1 covers switch-activated burglar alarms and includes exit and entry delays. Chapter 2 discusses other types of burglar alarms and includes Infra-Red, Ultrasonic and Doppler-Shift Systems. Chapter 3 covers other types of security devices such as Smoke and Gas Detectors; Water, Temperature and Baby Alarms; Doorphones, etc. Most circuits are simple, and stripboard layouts are provided.



To order Book BP56 and send \$5.99 includes shipping and handling in the U.S. and Canada only to **Electronics Technology Today Inc., P.O. Box 240, Massapequa Park, NY 11762-0240**. Payment in U.S. funds by U.S. Bank check or International Money Order. Please allow 6-8 weeks for delivery. ET09

TABLE 1

DISPLAY VALUE	RESISTOR
Blank	open (no resistor)
AM	65,000-ohm
FM	27,500-ohm
CW	15,000-ohm
USB	8750-ohm
LSB	5000-ohm
FSK	2500-ohm
FAX	short (wire jumper)