

THE Moon Probe programme and the startling astronomical developments over the last few years have created such interest that many people have bought small telescopes. Though a small instrument of up to 3 inches diameter is capable of satisfying the needs of most amateurs, half its potential is lost without adequate means of synchronously tracking the moon, planet, satellite or star under view.

This article describes the construction of a compact and relatively inexpensive drive unit using a mains type synchronous motor, driven from a constant frequency generator designed for 12 volt operation (batteries or mains unit), that can easily be fitted to tripod telescopes to provide tracking facilities. The system can also be used for larger telescopes with equatorial mountings.

TRACKING

The apparent motion of the stars about the north pole star is 360 degrees in 24 hours, or 15 degrees per hour; this figure is better appreciated in terms of sun or moon widths of approximately 0.5 degrees. The moon moves by its width every 2 minutes and since the optical gain or magnification of a telescope increases the apparent speed, it follows that high magnifications require constant use of slow motion controls to keep the object in view. Most small telescopes are fitted with a slow motion slewing control in the form of a knurled

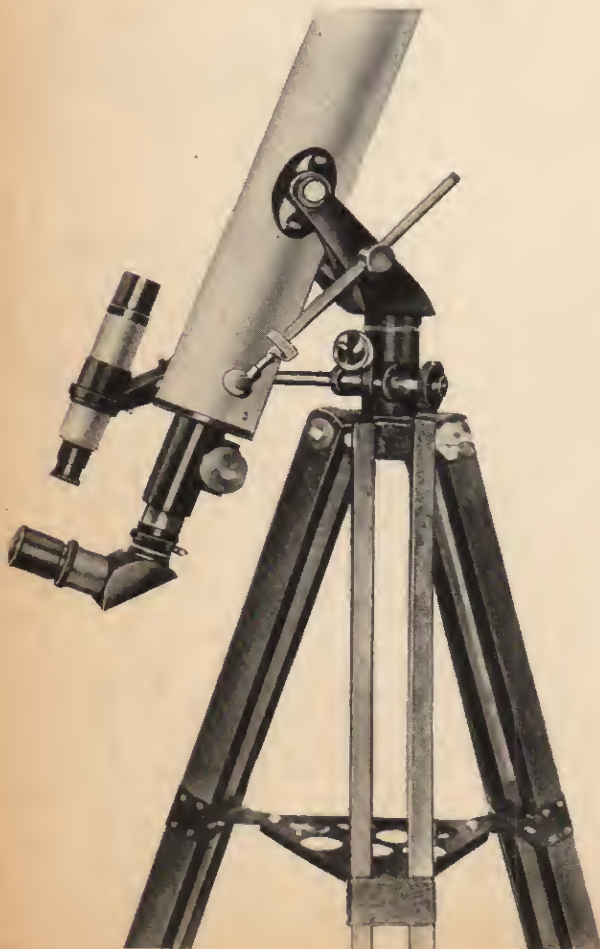

knob, spring loaded against backlash, that has a rate of about 0.5 degrees per revolution and a total slew of approximately 20 degrees.

Mains type synchronous motors fitted with reduction gearboxes are available on the surplus market, with a final speed of 0.25 to 4 revs per minute. Such a motor is fitted to the telescope frame and coupled to the slow motion knob by means of accurately fitted *high quality* gears to give a slew of approximately 15 degrees per hour with the motor energised at 50Hz. Using the circuit to be described the motor speed can be varied accurately by changing the frequency of the supply. Adequate torque is available from the motor to rotate the telescope and an anti-backlash device can be used, e.g., centre sprung double gears.

FREQUENCY GENERATOR

A hybrid unijunction bistable circuit is used for the frequency generator because:

- (1) The timing stability is excellent being dependent upon C_t and R_t according to $f = \frac{1}{2 R_t C_t}$ (where f represents frequency).
- (2) The stability is independent of transistor parameters and is reasonably independent of supply voltage changes.
- (3) The timing capacitor C_t may be quite small (0.1 to 0.22 μ Fd) and the inexactitude and variations of electrolytics are avoided.
- (4) The frequency may be readily and continuously varied over a wide range by changing only one component— R_t , and temperature compensation (if required) can be easily applied.
- (5) An equal mark to space ratio of well shaped rectangular wave form is obtained to feed a step up transformer.

The behaviour of the unijunction transistor is shown in Fig. 1. The capacitor C_t charges until the emitter voltage is approximately 60 per cent of the voltage across $b1, b2$ (peak point) when the emitter to $b1$ junction becomes almost a short circuit and the capacitor rapidly discharges.

TRACKER CIRCUIT

The unijunction transistor operating as described above fires the bistable circuit (Fig. 2) which is fitted with speed up capacitors $C2$ and $C3$, producing a rectangular waveform at the collectors of $TR3$ and $TR5$. Emitter followers $TR2$ and $TR6$ pass this waveform, via reverse voltage protective diodes $D1$ and $D2$, to the bases of $TR1$ and $TR7$ which perform a switching action and can therefore control powers of approximately 5 times that of the normal class A operation.

The emitter resistors $R1$ and $R15$ dissipate some useful power and reduce output voltage but apply local feedback to linearise the waveform and prevent thermal runaway. The values of $R1$ and $R15$ may be varied to increase efficiency or reduce current drain as desired; changing $R3$ and $R13$ to vary the base drive.

The collectors of $TR1$ and $TR7$ are connected to the centre tapped secondary winding of a small mains transformer $T1$; in this circuit the secondary winding is used as a primary. The primary winding forms a tuned secondary, the output of which feeds the synchronous motor to track the telescope.

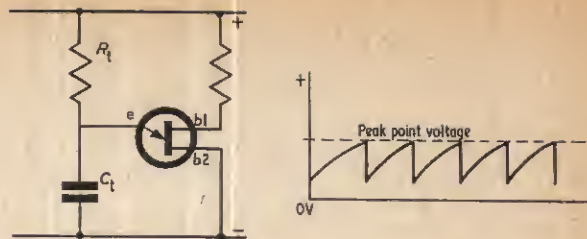

Fig. 1. Unijunction oscillator basic circuit and curve showing voltage variation across C_t .

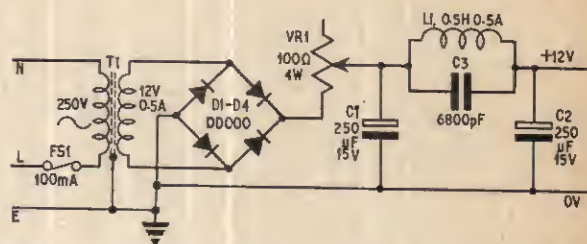

Fig. 3. Mains power supply for the telescope tracker

POWER SUPPLY

The circuit needs approximately 200mA at 12V d.c. and this can be supplied from a bank of U2 cells, an accumulator or alternatively from a simple mains power supply as shown in Fig. 3. In the mains supply circuit $VR1$ is adjusted to give 12 volts output on load and the choke $L1$ and capacitor $C1$ are resonated at mains frequency.

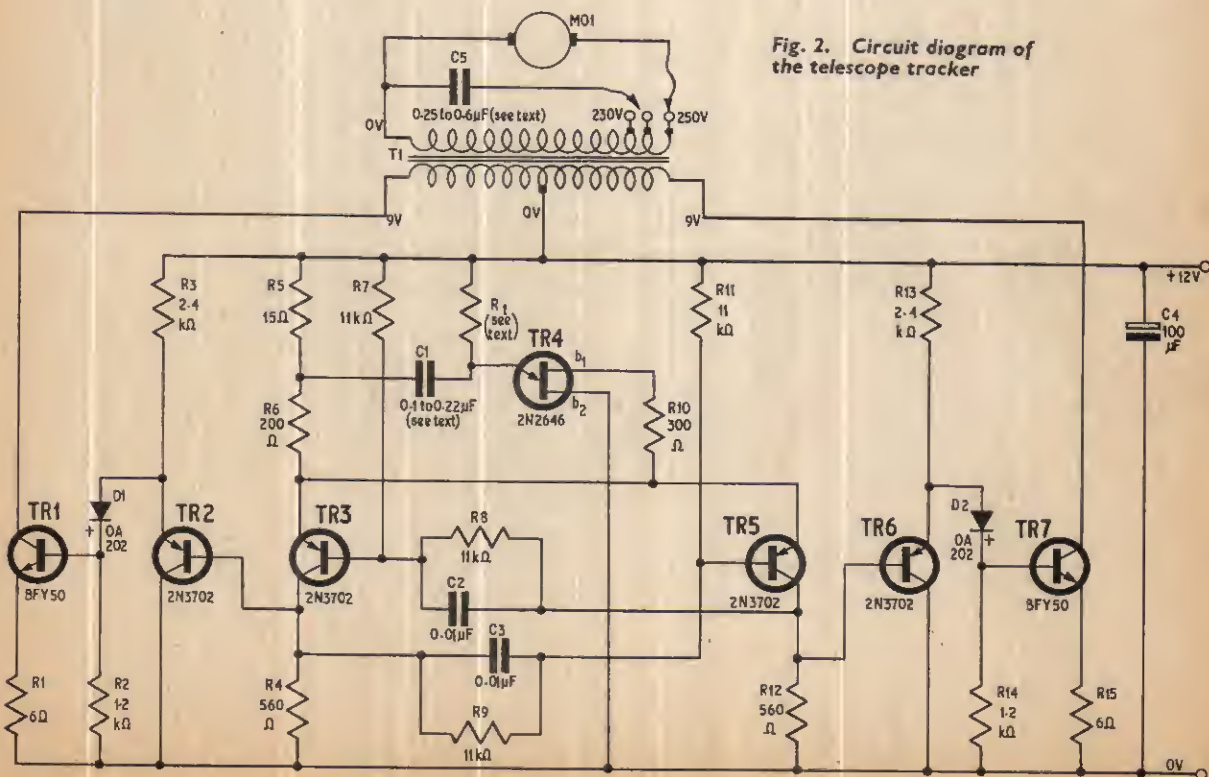

Fig. 2. Circuit diagram of the telescope tracker

CONSTRUCTIONAL DETAILS

COMPONENTS . . .

Resistors

R1	6Ω (2 × 12Ω in parallel)
R2	1.2kΩ
R3	2.4kΩ
R4	560Ω
R5	15Ω
R6	200Ω
R7	11kΩ
R8	11kΩ
R9	11kΩ
R10	300Ω
R11	11kΩ
R12	560Ω
R13	2.4kΩ
R14	1.2kΩ
R15	6Ω (2 × 12Ω in parallel)
R16	approx. 20kΩ
R17	approx. 30kΩ
R18	approx. 30kΩ
All 1/8W carbon 5%	

Potentiometers

VR1	20kΩ carbon preset
VR2	10kΩ carbon preset
VR3	20kΩ carbon lin.

Capacitors

C1	0.1μF-0.22μF (see text)
C2	0.01μF polyester
C3	0.01μF polyester
C4	100μF elect. 15V
C5	0.25μF-0.6μF 450V (see text)

Semiconductors

D1	OA202
D2	OA202
TR1	BFY50
TR2	2N3702
TR3	2N3702
TR4	2N2646 (unijunction)
TR5	2N3702
TR6	2N3702
TR7	BFY50

Switches

S1	3-way wafer
S2	single-pole on/off toggle
S3	single-pole on/off toggle

Miscellaneous

T1	Mains transformer 200/250V primary 9V-0-9V secondary—used in reverse (Douglas L.T. type)
M01	Synchronous mains motor, 0.25-4 r.p.m.
Printed circuit board, metal case, gears	

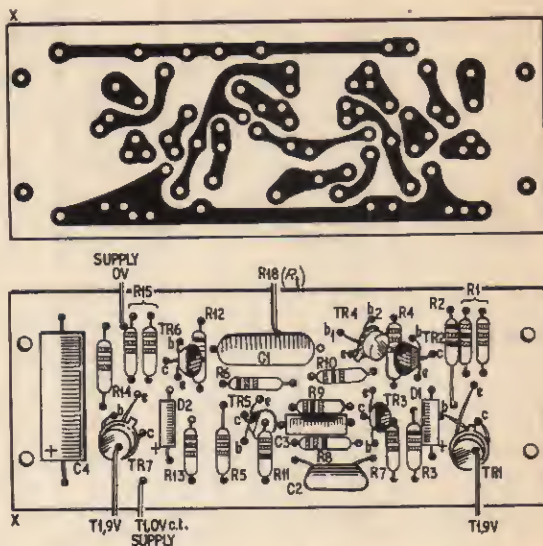

Fig. 4. Layout and wiring of the printed circuit board

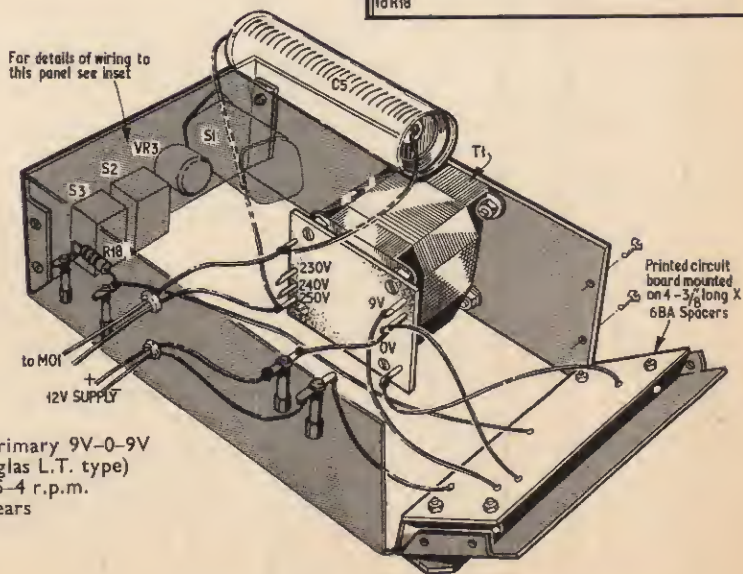
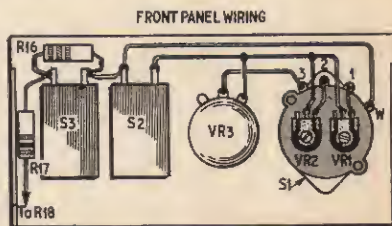
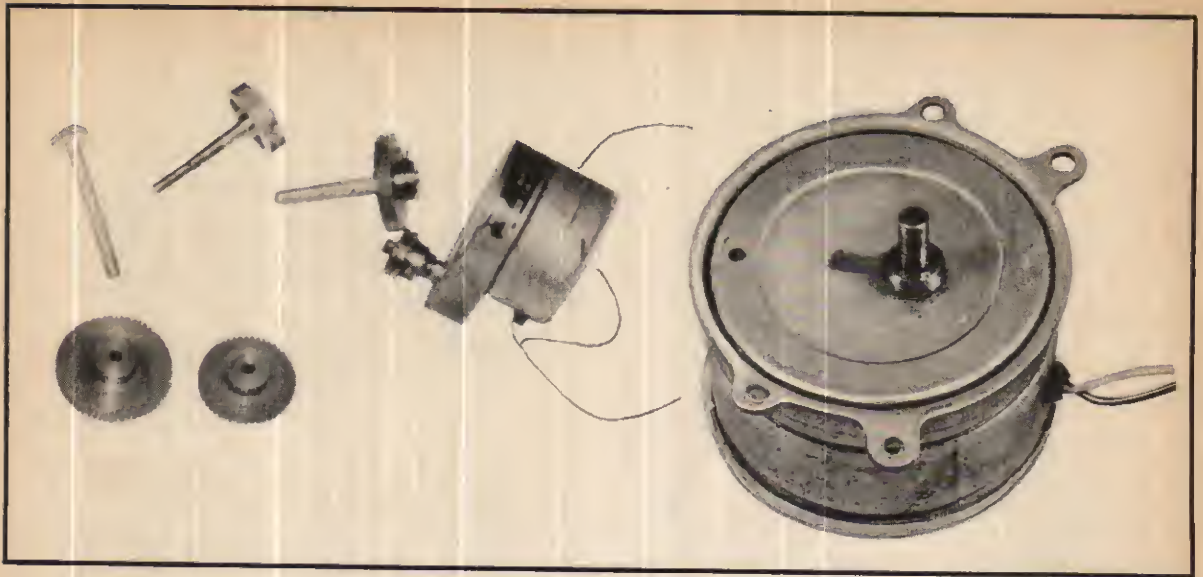

Fig. 5. Wiring diagram of the components mounted inside the tracker case



CONSTRUCTION

Most of the components are mounted on a printed circuit board, shown full size in Fig. 4. The board is fitted, together with the output transformer (T1), C5, the controls and associated resistors, inside a metal case of suitable size. A layout and wiring diagram of the components inside the case is shown in Fig. 5. The mains or battery supply is accommodated outside the case as is the tracking motor MO1.

When the telescope is tripod mounted and has a slow motion tracking screw the motor may be geared directly to this screw and hence revolve the telescope through an angle of some 20 degrees. The coupling gear ratio can be ascertained by calculation of the number of revolutions of the tracking screw to swing the telescope through 15 degrees. Assuming the speed of the motor is known the gear ratio can be found in the following manner

$$\text{Gear ratio} = \frac{\text{motor speed in rev. per min.} \times 60}{\text{revolutions of tracking screw required for 15 degree swing}}$$

Assuming the motor speed to be 0.5 r.p.m. and that 15.5 turns of the slow motion screw produce a 15 degree swing of the telescope the gear ratio required is:

$$\frac{0.5 \cdot 60}{15.5} \text{ or } 30/15.5$$

Since this is almost 2/1, gears of that ratio may be used and the slight error will be easily compensated by frequency adjustment in the circuit.

TESTING

The circuit should be set up with a polyester capacitor of 0.22 μF as C1 and a 100 kilohm resistor as R_1 ; the output waveform is examined on an oscilloscope and C5 adjusted until the waveform is as shown in Fig. 6b. If an oscilloscope is not available then the transformer should be resonated, with the load applied, by monitoring the output voltage with a voltmeter (approximately 180V r.m.s.) and adjusting C5 in fine increments for a maximum reading.

Use should be made of the primary tapings of the transformer (if available) not only to achieve the required output but to incrementally change the effect of C5.

Fig. 6a indicates an output waveform without C5 and Fig. 6c shows a waveform with the transformer resonated for 50Hz but with the generator frequency changed.

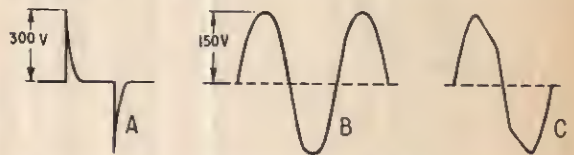
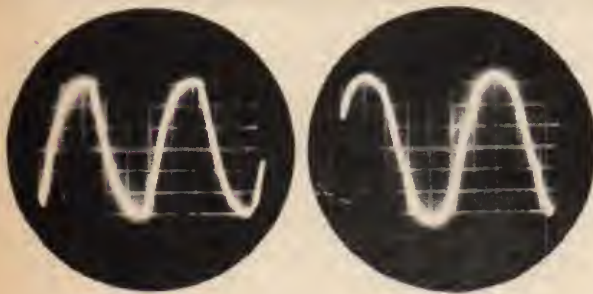

Fig. 6. Graphs of output voltage (a) without C5, (b) in resonance, (c) with transformer resonated for 50Hz but with the generator frequency changed





Off tune waveform
50V per division,
130V Avo monitor

On tune waveform
50V per division,
140V Avo monitor

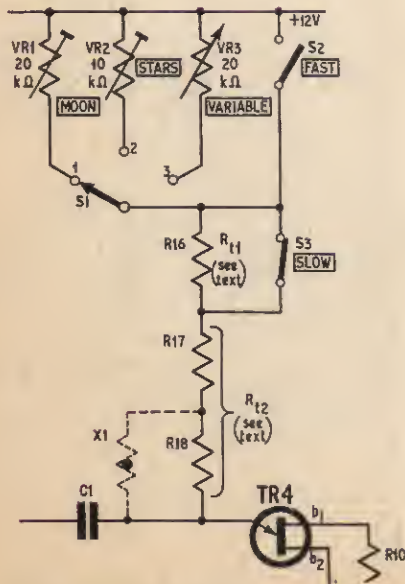

Fig. 7. Control circuit used to replace R_t in telescope tracker circuit

The output frequency should be accurately determined by connecting the generator to a household electric clock and noting the timing error over a period of hours. If this frequency is not close to 50Hz R_t should be changed and C5 readjusted. Finally, with C1 and C5 set for 50Hz replace R_t with a variable resistor to slow the frequency until the drive motor to be used will no longer start up on load: this value of R_t should be measured as $R_{t \text{ slow}}$; similarly determine the upper limit $R_{t \text{ fast}}$. The output voltage should be at least 150 volts r.m.s. in the slow and fast condition dependent upon R1 and R15.

CONTROL CIRCUIT

The timing resistor R_t is replaced by the circuit of Fig. 7. Switch S3 (slow) is replaced by the circuit of Fig. 7. Switch S3 (slow) is normally closed, and when S2 (fast) is closed resistor combination R_{t2} has the value of $R_{t \text{ fast}}$. The variable resistors VR1, VR2 and VR3 are chosen and adjusted for star, moon and auxiliary rates and switch S3 is used to introduce R_{t1} such that $R_{t1} + R_{t2} + VR1$ (etc.) = $R_{t \text{ slow}}$. The thermistor indicated may be used to shunt part of R_{t2} to give temperature compensation (if required) for the temperature coefficient of C1 (of the order of +300 parts per million per degree centigrade).

FINAL SETTING UP

Direct the telescope to a bright star group and use the fast and slow switches to centralise the group such that stars can be observed on the edges of the field of view. Preset VR2 is adjusted until the group is synchronously tracked. Repeat the above procedure using the moon, which moves relative to the stars, and adjust VR1 using a prominent crater as a marker. The remaining variable resistor VR3 is fitted with a suitable knob and used to track satellites, etc.

If the drive is fitted to a telescope, with an equatorial mount, as a 360 degree drive, the adjustment of VR2 can be accurately set by leaving the unit powered and performing a 24 hour check, preferably with the generator kept indoors at a reasonably constant temperature. The degree of temperature compensation can then be determined by noting the angular error over 24 hours for a given temperature change and determining the necessary change in the value of R_t to correct this. It will be found that a thermistor that changes from, say 10 kilohms to 3 kilohms (0 degrees C — 30 degrees C) can be used as indicated in Fig. 7 to compensate for the change in value of C1. ★