

48783

**NEW!
DIRECT-ETCH
FOIL PATTERNS INCLUDED**

**THE RIGHT WAY TO
HOOK UP YOUR VCR**

**\$1.95 AUGUST 1985
IN CANADA \$2.25**

Radio- Electronics®

TECHNOLOGY - VIDEO - STEREO - COMPUTERS - SERVICE

**Build a universal 64K
printer buffer for
your computer**

**Build R-E's infrared viewer
and see in the dark!**

How to design with digital IC's

**Build the HiTech
PC - IBM compatibility
without the IBM price**

**How comb filters
work to improve
video - system performance**

**Electric shock
and how it affects you**

**Special 16-page section:
COMPUTERDIGEST**

Attention retailers:
See page 26 for special
display allowance plan.

PLUS:

- ★ **Robotics** ★ **State-Of-Solid-State**
- ★ **Drawing Board** ★ **Service Clinic**
- ★ **Equipment Reports**

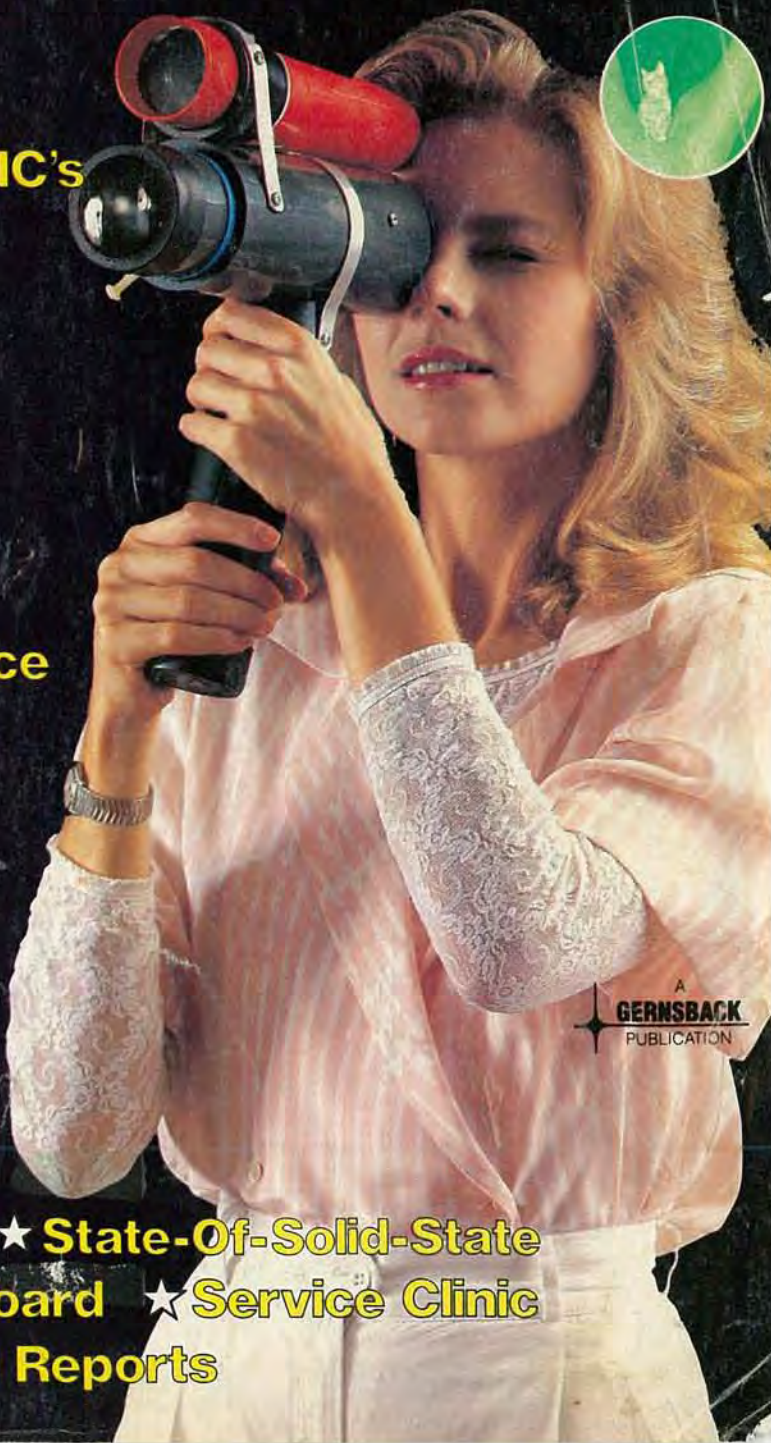

**A
GERNSBACK
PUBLICATION**



BUILD THIS

SEE-IN-THE-DARK

THE PHRASE "SEEING IN THE DARK" is a misleading one. With the possible exception of mystics and mutants, when the lights go out, we all walk into walls. Being able to see in the dark all depends on what you mean by "dark." The human eye is only sensitive to a very narrow band of the electromagnetic spectrum, as shown in Fig. 1. Figure 2 shows the eye's relative sensitivity to wavelengths in that narrow band.

The infrared portion of the electromagnetic spectrum is just below visible light and extends from about 700 to well past 10,000 millimicrons. The human eye is normally insensitive to electromagnetic radiation in that region. In order to produce a visible image using infrared light, then, we need a device that's both sensitive to infrared and able to translate an infrared image into one that the human eye can see. One such device is the RCA 6032 image converter tube, and that tube is the heart of the infrared viewer that we'll show you how to build.

The 6032 can be thought of as being divided into two parts. The front end is a photosensitive cathode that responds to infrared radiation in the range of 500 to 1200 millimicrons. Whatever image is focused on the cathode is reversed left-to-right and passed on to the second part of the tube. That is a small fluorescent screen on which the visible image is formed. Focusing the image on the screen is done electrostatically—a voltage is applied to the focus ring at the tube's center and controls the convergence and divergence of the electrons being aimed at the screen's phosphor. That is similar to the way the electron gun is focused in a television set.

Building the viewer

The schematic of our viewer is shown in Fig. 3. As you can see, the circuit's only job is to produce the voltages that the image converter tube needs to operate. Before we start talking about how the circuit works and what's needed to actually build it, there are two things that have to be said.

CAUTION! The tube needs about 12,000 volts to operate, and 12,000 volts is a very serious amount of voltage! Because of that, the utmost care must be



VIEWER

ROBERT GROSSBLATT

*"See in the dark"
with this easy-to-build
infrared viewer!*

observed when working with this circuit. Any carelessness is dangerous, and could very possibly be fatal. BE VERY, VERY CAREFUL!

That caution should be taken seriously, even though the circuit is powered by a 9-volt battery. That's because our power supply is capable of producing as much as 15,000 volts from a fresh battery. Also, although the tube only needs a handful of microamps to operate, the supply can produce over 200 microamps. There's a world of difference between 200 microamps at 10 volts and 200 microamps at 15,000 volts! Once again, 15,000 volts can be lethal, even if the current is negligible. Be careful!

Secondly, the tube itself is made of glass and, just as any other type of electronic tube, it contains a vacuum. Although the glass is thick and the tube is

strong, the tube will implode if punctured. Now, flying glass from such an occurrence is bad enough, but the phosphor on the screen can do you a lot of damage if it gets into a cut. To avoid any problems, handle the tube carefully and when you solder the high-voltage leads on the tube, make sure the iron is in contact with the tube for as short a time as possible. Tin the wire ahead of time and *never—repeat, never—*solder near the tube's glass seals.

Keeping those warnings in mind, let's take a look at the circuit.

The first stage of the power supply is an oscillator formed basically by Q1, Q2, and part of the primary of T1. Resistor R1 keeps the circuit unbalanced so that oscillation will start when power is first applied. The base current for the transistors is produced by induction in T1 and is limited by R2. The switching action of the transistors causes the induced voltage in T1 to switch polarity and that alternatively turns on Q1 and Q2 in turn. The two diodes, D1 and D2, are steering diodes for the base current.

When S1 is closed, current flows through R1 and T1. The base drive for the transistors comes from T1's stand-alone winding. Because the two transistors are being driven out of phase, the circuit begins to oscillate. That causes an induced voltage to appear across T1's secondary. How great that voltage will be depends on how much voltage is available from the battery. Assuming

that the battery is between 7 and 9 volts, the induced voltage on T1's secondary will be between 200 and 300 volts.

That voltage is rectified by the full-wave bridge made from diodes D3 to D6. Capacitor C2 is charged through D7 and R3, setting the stage for the next part of the circuit's operation. Transistor Q3 is the center of a timing circuit with an R-C constant determined by the values of R6, R7, and C3. The 15-microsecond pulse produced by that part of the circuit fires SCR1, and causes C2 to discharge, inducing a high-voltage pulse in the secondary of T2. That voltage is rectified by D9.

The voltage produced by the discharge of C2 is boosted by the inductance of T2's primary and that negative overshoot causes the SCR to turn off. As soon as the SCR turns off, the whole process starts all over again.

The image-converter tube requires a high voltage in order to focus the image on the fluorescent screen. That voltage is applied via a voltage-divider circuit made up of R8 and R9. Don't forget that by the time power gets up to the tube, we're talking about some 12,000 volts at fairly high peak-current values. The values for those two resistors are extremely high because only flea power is needed at the focus ring of the tube. Excessive current can destroy the tube, so the resistor values are probably higher than you've ever seen before.

Getting the tube to produce a sharp image is a matter of providing the right voltage at the focusing ring. The value of 2000 megohms for R9 can be considered a final value, but the voltage will have to be adjusted by daisy-chaining resistors together to form R8. A value of 200 megohms is a good starting point; the optimum value, which varies from tube to tube, will be within 15% of that.

If the operation of the power supply seems familiar to you, it's probably because the same basic principles are used in the design of most automobile capacitive discharge systems. The same sort of

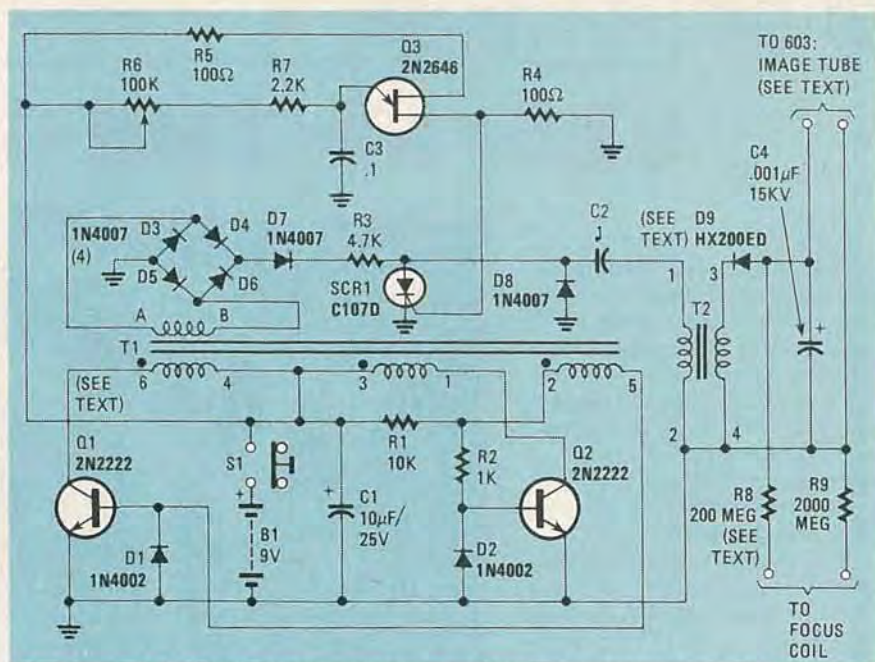

FIG. 3—THIS POWER SUPPLY can produce up to 15,000 volts from a single 9-volt nickel-cadmium battery.

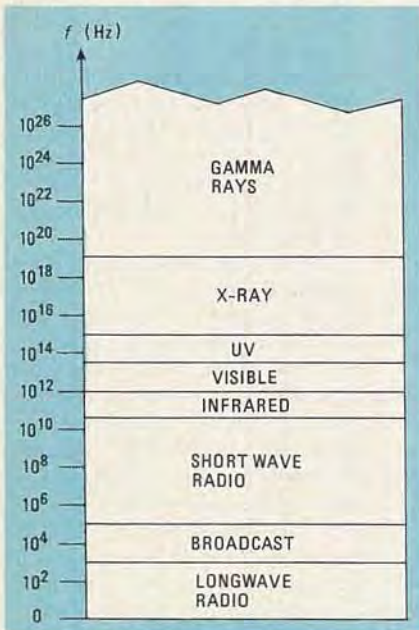

FIG. 1—VISIBLE LIGHT takes up only a small slice of the electromagnetic spectrum.

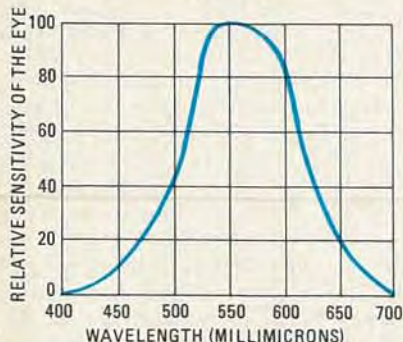

FIG. 2—THE EYE IS most sensitive to light in the range of 550 millimicrons.

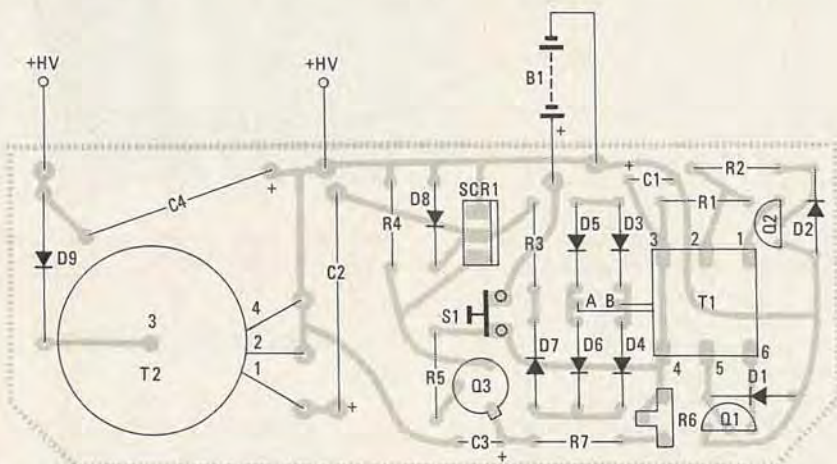

FIG. 4—IF YOU CHOOSE TO use a PC board, this parts-placement diagram should be followed.

pulsed high voltage is needed to make the spark plugs fire. And if you've ever fooled around under the hood of a car, you know that you can be knocked over backward by the juice at the plugs. Once again: **BE CAREFUL WHEN YOU ARE WORKING WITH THE HIGH VOLTAGES INVOLVED IN THIS PROJECT.**

Construction

Building the circuit for the infrared viewer is relatively straightforward and can be done on either a perfboard or PC board. We recommend using a PC board; an appropriate pattern is provided in our "PC Service" section, on page 78, and the corresponding parts-placement diagram in Fig. 4.

Whatever method you choose, because we're dealing with high voltages, there are several considerations that are different from a low-voltage circuit:

- All solder joints must be clean and shiny. Because of the voltages involved, anything less than a perfect joint will cause arcing.
- Leads must be absolutely cut as short as possible.
- All the components on the board, and especially those that follow T1, should be locked in position with paraffin, varnish, or high-voltage putty.

The first step is to mount and solder the components onto the board. Do not, however, mount the high-voltage portion of the circuit (T2 and the circuitry on the secondary side of that transformer). Before building that part of the circuit, you need to verify that the balance of the project is operating correctly. When you mount the components on the board, pay attention to the polarities of the diodes and capacitors. Make sure that the transistors are correctly oriented and the transformer

leads are properly identified. Do your soldering only when you're sure that everything is correct.

The next step is to verify that everything to this point is operating correctly. Connect the leads from an ohmmeter to the battery clips and press S1. That is an easy way to make sure you don't have a short across the power supply. If that checks out fine, connect the power leads to a 6-volt supply and measure D7's anode voltage. You should see about 175 volts there, and the drain on the 6-volt supply should be no more than 75 mA. *Be very cautious* when you're taking those measurements. It may seem that 175 volts is a long way from 15,000 volts, but that voltage can still do a bit of damage.

Once everything checks out, you can mount and wire the rest of the circuit. If you don't get the proper readings, check your connections on the board again. The circuit is simple enough for you to be able to find your mistake without too much irritation.

Take the high-voltage leads and tape them down so that they're about a quarter of an inch apart. Connect the circuit to the 6-volt source again and you should see sparking at the output. You have to adjust R6 for the minimum spark rate. If you watch the current draw, you should see it drop as the sparking rate is reduced.

Once again a word of caution. Anytime you're adjusting a circuit that produces high voltage, you want to be absolutely sure to isolate yourself from the board. That means that a metal-bladed screwdriver, or anything else metal, for that matter, to make adjustments is a definite no-no. And contrary to popular belief, you don't want to use a wooden anything either. High voltages do weird things and that includes traveling through anything that is even the least bit conductive. Wood is porous, can absorb moisture from the air; the result can very well be you lying on the floor!

Once you've finished assembling the high voltage supply and you're sure it works, you're ready to tackle the image converter tube. But just as there was for the power supply, there are some precautions to keep in mind for this part of the assembly as well.

- When you're soldering connections to the various rings on the tube, do it as quickly as possible. Tin the wires before you solder the connections. If you apply too much heat for too long, you'll destroy the glass-to-metal seals on the tube.

- The tube is made of glass and contains a vacuum. The weakest points on the tube are at the small areas where the glass was sealed after the tube was assembled. **Keep your iron and any solder away from the glass in general and those seals in particular.** The glass can implode and the phosphor coating on the screen can cause you a great deal of trouble.

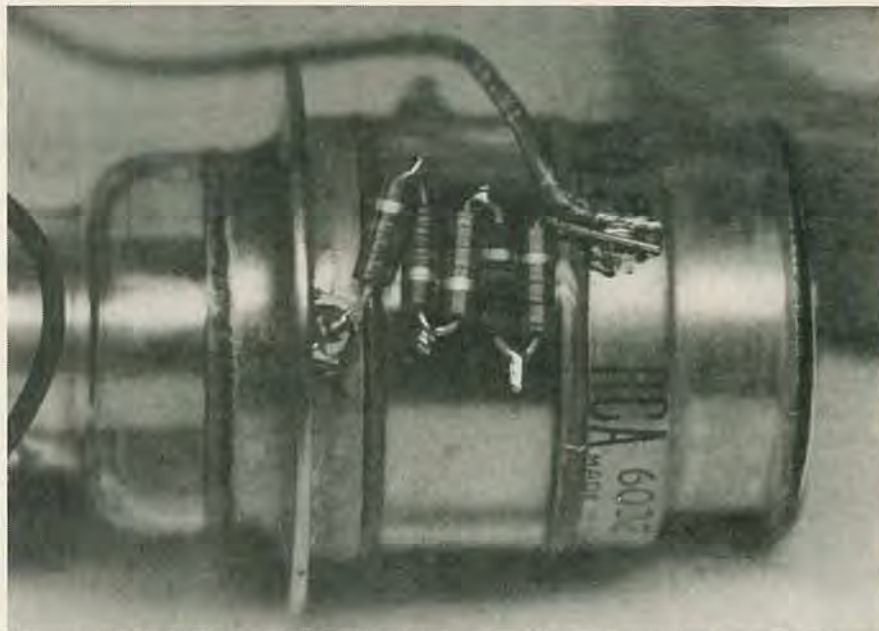

FIG. 5—SEVERAL RESISTORS will need to be daisy-chained to obtain the value needed for R8.

With those precautions in mind, solder R9 between the focus ring and the ring surrounding the fluorescent screen. Once you've done that, solder short pieces of wire to the ring surrounding the objective end of the tube and another point on the focus ring. Temporarily connect R8 across those pieces of wire as well as the high voltage leads from the power supply. Make sure that the lead coming from the D9-C4 junction on the power supply board is connected to the R8/objective end of the imaging tube and the other lead is connected both to ground on the board and the R9/eyepiece end of the tube.

When you've made sure that everything is hooked up properly, apply power to the circuit and you should see the phosphor at the eyepiece end of the tube glow with a green light. Turn off the power and fasten a piece of window screening flush against the objective end of the tube. Re-apply power and you should see an image of the screening on the phosphor screen. Your next step is to adjust the value of R8 to make the image as sharp as possible. Varying the voltage at the focusing ring changes the electrostatic focus of the tube. You'll have to experiment with a number of resistor combinations to find the value that produces the sharpest focus. As we said before, 200 megohms is the nominal value and the correct value for your tube is probably within plus or minus 15 percent of that.

Once you've daisy chained the resistors together and soldered them to the imaging tube (see Fig. 5), you have only one more final test to do before you can call it a wrap. Turn out the lights and apply power to the circuit again. What you're looking for here is evidence of high voltage leaks. Those will show up as small sparks or "corona." Note the places where they

show up and turn the power off. Wait a second or so for the circuit to discharge, then insulate those areas with high-voltage putty.

Believe it or not, once you've made sure that the focus is as sharp as you can make it, (or is at least acceptable to you), and there's no evidence of corona, the project is completed.

Now we come to the question of the case. You need a focusing lens in front of the tube and a viewing lens at the rear. In order for the front lens to focus a sharp image on the tube's objective, both the tube and the lens have to be on the same axis. And the same conditions apply to the

MEASURING WAVELENGTH

Whenever you're talking about the electromagnetic spectrum, some confusion can arise over the units used to refer to the wavelength of the radiation.

As you move up the spectrum from DC toward daylight, the frequency of the radiation will increase and the wavelength will decrease. Those two measurements are related by "c," the speed of light through: $\lambda = K(f/c)$

where λ is the wavelength, f is the frequency in Hertz, c is the speed of light, and K is a constant determined by the medium through which the radiation is travelling.

Although you can refer to the wavelength in meters, by the time you get up to the visible part of the spectrum, the wavelengths are pretty small. Green light, for example, has a wavelength of about 550×10^{-9} meters. The two most common units of measurement for the upper reaches of the spectrum are the millimicron (10^{-9} meters) and the Angstrom (10^{-10} meters). The latter is named after the 19th-century Swedish physicist A. J. Angstrom.

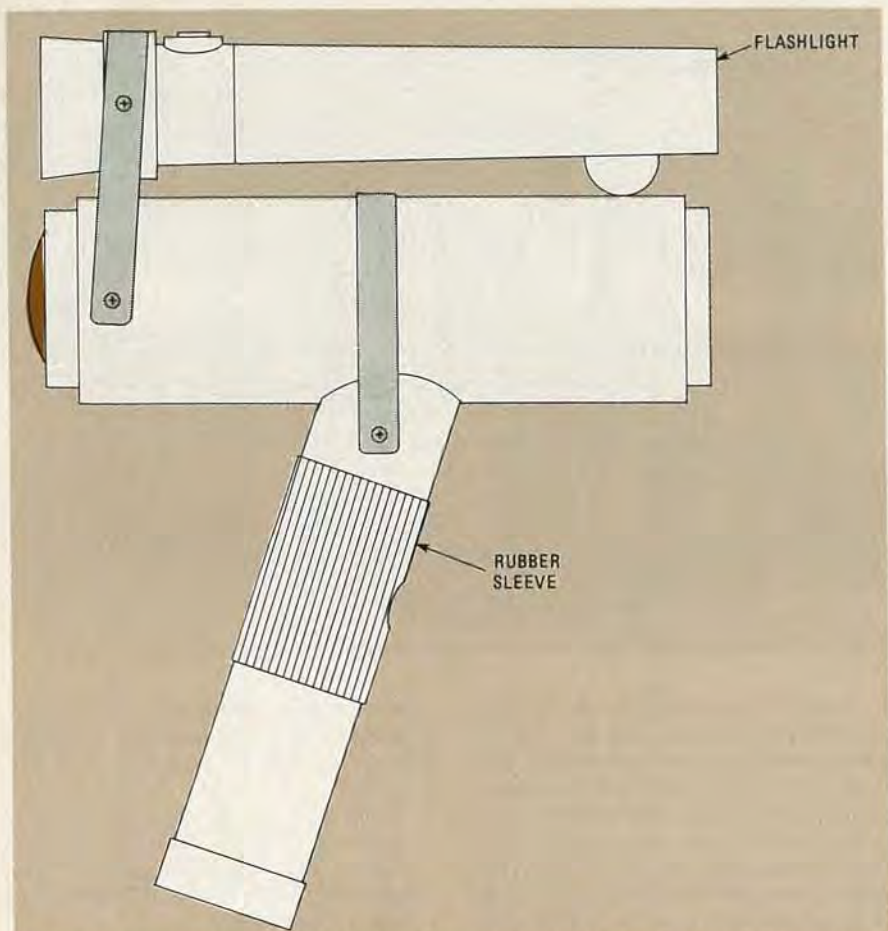

FIG. 6—THOUGH THE CASE is not critical, here is one that works well. The flashlight at the top is fitted with an infrared filter for use as a source of infrared light.

viewing lens at the rear. The easiest solution to the problem is to use a piece of tubing to hold the whole assembly. PVC tubing is perfect for that purpose.

A length of 2½-inch diameter PVC will hold the imaging tube if you shim the ends with 2⅜-inch tubing. The same 2⅜-inch tubing can also be used to mount the front and rear lenses. Use set screws to hold the 2⅜-inch tubes inside the main PVC enclosure.

One appropriate case is shown in Fig. 6. The optics in that unit are encased as just described. The PVC handle contains the power supply board and the battery. Once the board is mounted, cut a hole out over S1 so that it can be conveniently pressed. To prevent accidental contact with the board, slide a flexible rubber sheath (a section from an old bicycle tire inner tube will do) over the handle so that the hole is covered.

Note that there is nothing critical about the case. When designing and building a case for your unit, the only precaution is to make sure that no extraneous light can leak inside the tube, because that will degrade the quality of the image. Black tape or putty can take care of any light leaks.

Once you have the viewer assembled, you're ready to explore the world of in-

frared light. It's interesting, and somehow reassuring, to watch a television remote control. Yes, they really do put out bright flashes of previously invisible infrared. If you put an infrared filter in front of a flashlight, you'll be able to see in the dark by using the flashlight and peering through the viewer. (You'll note that the unit shown has such a flashlight mounted on it. That flashlight serves as an infrared light source. Also note that once the infrared filter is in place; the light emitted by the flashlight can not be seen by the naked eye.) Deep infrared filters are expensive but a piece of unexposed but developed Kodachrome will do almost as well. Use the ends that come back in the box along with your developed slides.

Infrared energy is also produced by heat. You can prove that by getting a steam iron nice and hot and putting it next to a piece of newspaper. Turn out the lights, look through the viewer, and you'll be able to read by the heat of the iron.

As to the quality of the image you see using the viewer, there are two limiting factors. Those are the "brightness" of the infrared source, and the quality of the optics used.

Turning first to the brightness of the source, the unit shown uses a common flashlight as described. That should be

PARTS LIST

All resistors ¼ watt, 10% unless noted

- R1—10,000 ohms
- R2—1000 ohms
- R3—4700 ohms
- R4, R5—100 ohms
- R6—100,000 ohms, potentiometer
- R7—2200 ohms
- R8—200 megohms, see text
- R9—2000 megohms, see text

Capacitors

- C1—10µF, 25 volts, electrolytic
- C2—1µF, 400 volts, electrolytic
- C3—1µF, 25 volts, electrolytic
- C4—.001µF, 15 kV, ceramic

Semiconductors

- Q1, Q2—2N2222 NPN transistor
- Q3—2N2646 FET transistor
- D1, D2—1N4002
- D3—D8—1N4007
- D9—MX200EP, 20-kV diode
- SCR1—C107D

Other components

- B1—9-volt nickel cadmium battery
- S1—SPST, momentary pushbutton, normally open
- T1—12 to 400 volts, 10kHz switching transformer
- T2—11 kV pulse transformer, 400-volt primary

Miscellaneous: 6032 image tube (RCA), PC board, PVC tubing for case, focusing and viewing lenses, battery clip, flashlight, wire, solder, etc.

The following are available from Information Unlimited, PO Box 716, Amherst, NH 03031: Complete kit, including case and basic lenses, but minus the 6032 image tube, \$99.50; 6032 image tube, \$49.50; assembled and tested unit \$199.50; power board kit \$34.50; assembled power board, \$49.40; T1 alone, \$14.50; T2 alone, \$15.50; D9 alone, \$2.50; C4 alone, \$3.00; optional 75mm telephoto focusing lens with iris adjustment and C-mount, \$125.00; optional 50mm wide-angle focusing lens with C-mount, \$95.00.

sufficient in most cases. If not, a brighter source of light can be substituted, as long as an infrared filter is used as outlined above.

The optics (lenses) are much more critical. The standard optics supplied with the kit offered by the source mentioned in the Parts List are adequate for most hobbyist applications. If you require images with more sharpness and clarity, however, you will need to use higher quality, and more expensive lenses. Such lenses are also available from the source given in the Parts List.

The uses of infrared imaging are endless and eye opening. If you want to find out more about the subject, Kodak publishes a wonderful booklet called "Applied Infra Red Photography." Write to Kodak, Consumer Markets Division, Rochester, NY 14650. R-E

PC SERVICE

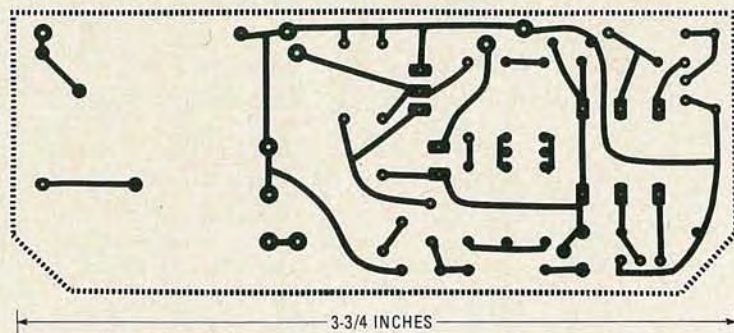

SOLDER SIZE OF THE INFRARED VIEWER board is shown here in a full-size mirror image. This side goes toward the board to be exposed. See page 49.