



# Hear with Ultrasound Using a TL494 as a Flanagan Neurophone

Written By: Andreas

## TOOLS:

- [Oscilloscope \(1\)](#)
- [Signal generator \(1\)](#)

## PARTS:

- [TL494 chip \(1\)](#)
- [Small Breadboard \(1\)](#)
- [10KΩ Potentiometer \(1\)](#)
- [47k potentiometer \(1\)](#)
- [1/4W 5% 10K resistor \(1\)](#)
- [.047uF 100v capacitor \(1\)](#)
- [0.001uF capacitor \(1\)](#)
- [Ceramic capacitor, 0.1uF \(2\)](#)
- [100uF / 25v capacitor \(electrolytic\) \(1\)](#)
- [9V battery \(2\)](#)
- [Piezo Element \(2\)](#)
- [Wire \(1\)](#)

## SUMMARY

Patrick Flanagan invented the "Neurophone" over 40 years ago. His original patent (US3393279) was basically a radio transmitter that could be picked up by the human nervous system. It modulated a one-watt 40kHz transmitter with the audio signal, and used very near-field antennas to couple it to the body. It also used extremely high voltages.

Fortunately, we don't need to work with radio transmitters or high voltages. Over a decade later, Flanagan came up with a version of the "Neurophone" that didn't use radio, or high voltages. (Patent US3647970)

The second version of the "Neurophone" used ultrasound instead. By modulating an ultrasonic signal with the audio we want to listen to, it gets picked up by a little-known part of the brain and turned into something that feels like sound.

The weird thing is this works even if the ultrasound transducers are far away from the head: maybe down at your waist, or even further (depending on your body).

### Step 1 — Hear with Ultrasound Using a TL494 as a Flanagan Neurophone

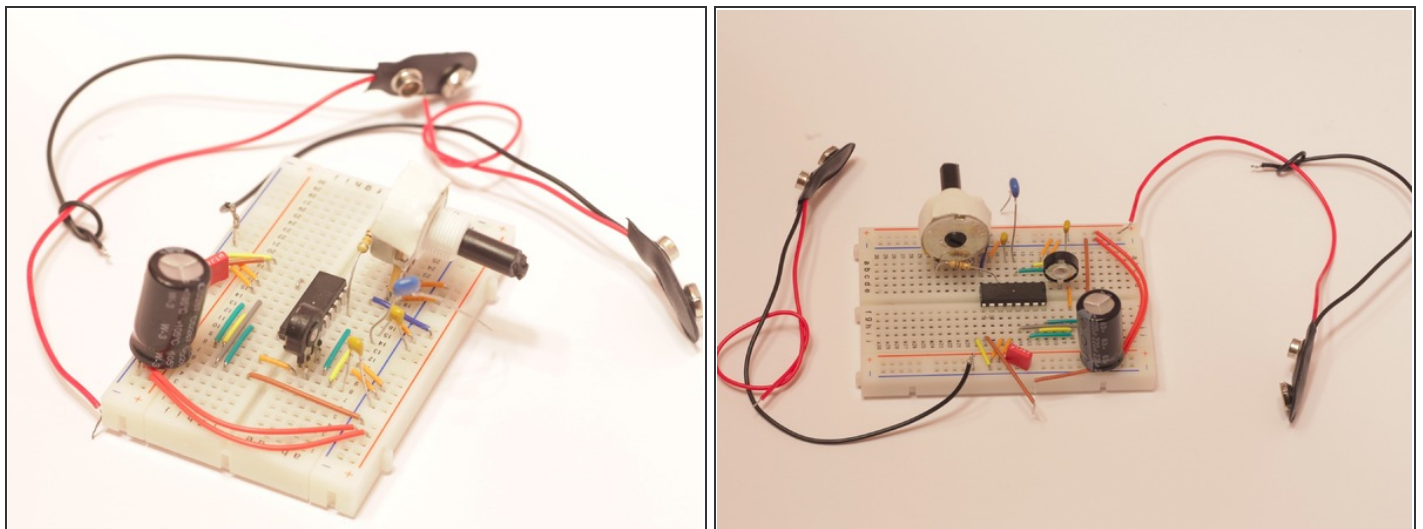

- To make the ultrasound signal, we'll use a widely-available TL494 pulse-width modulation controller. This isn't a perfect solution, so you won't hear the signal as well as with one of Flanagan's designs. But it's a lot simpler than messing around with DSP. And it gives you a chance to experience and experiment with the "Neurophone" effect.

## Step 2

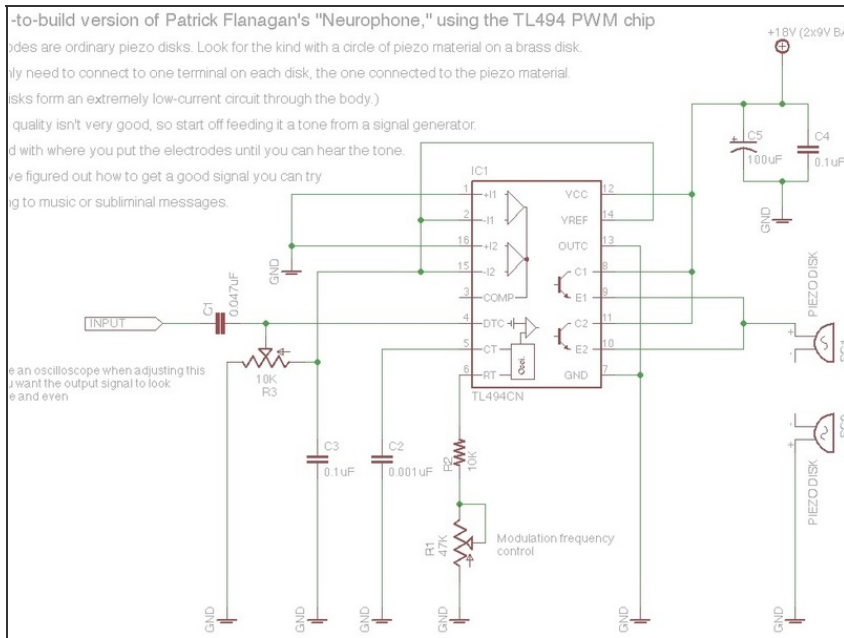

- Have a look at the schematic. You'll see there are two adjustment potentiometers.
- The first potentiometer is near the input, and it adjusts the DC bias of the input: whether the TL494 thinks the input signal is mostly positive, neutral, or mostly negative. The best way to adjust it is by connecting an oscilloscope to the circuit's output. Connect a sine wave signal generator to the input.
- (If you don't have a signal generator, generate a 440Hz sine wave in the open-source Audacity music editor and upload the file to an MP3 player.) You then adjust the potentiometer until the signal looks about even between top and bottom. If you don't have an oscilloscope, try with the potentiometer centered.
- The second potentiometer controls the modulation frequency. Using your oscilloscope or a frequency counter, turn it until you get about a 40-50kHz signal from the output (with nothing connected to the input). If you don't have either of those, play with the control until you can hear the signal.

**Step 3**



- The 'electrodes' are actually transducers. You can pick up the piezo disks online, or at an electronics shop. Try searching for 'piezo' or 'piezo element.' You only need to connect to the piezo side on each: the disks form an electric circuit through the surface of the skin.
- (This may help the signal be heard, since nerves are sensitive to electricity too.) Don't worry: there's so little current flowing between the electrodes that you'll feel nothing. (And while I'm not a medical professional, I don't think there's any way it could do any harm.)
- Do be careful about putting them on and taking them off, though. They're putting out a fairly high-power ultrasound signal, so if they sit too loosely on the skin they could irritate it.
- Lastly, you'll probably find the signal is easiest to hear 'in your head' with the electrodes near your head. Also, and this applies double if you're putting the electrodes far away from your head, you'll probably only be able to 'hear' a very narrow range of frequencies.
- A signal generator where you can easily vary the signal from 20Hz to 20,000Hz is very helpful in finding what you can hear and what you

can't.

- Oh, and don't forget to play with the volume control on your signal generator or MP3 player: you may need to set it a lot higher or lower than with regular headphones.

This document was last generated on 2012-10-31 10:38:37 AM.