

# Lie Detector

**We make no pretence to accuracy, but this simple skin resistance detector is instructive to build.**

T.R. de VAUX-BALBIRNIE

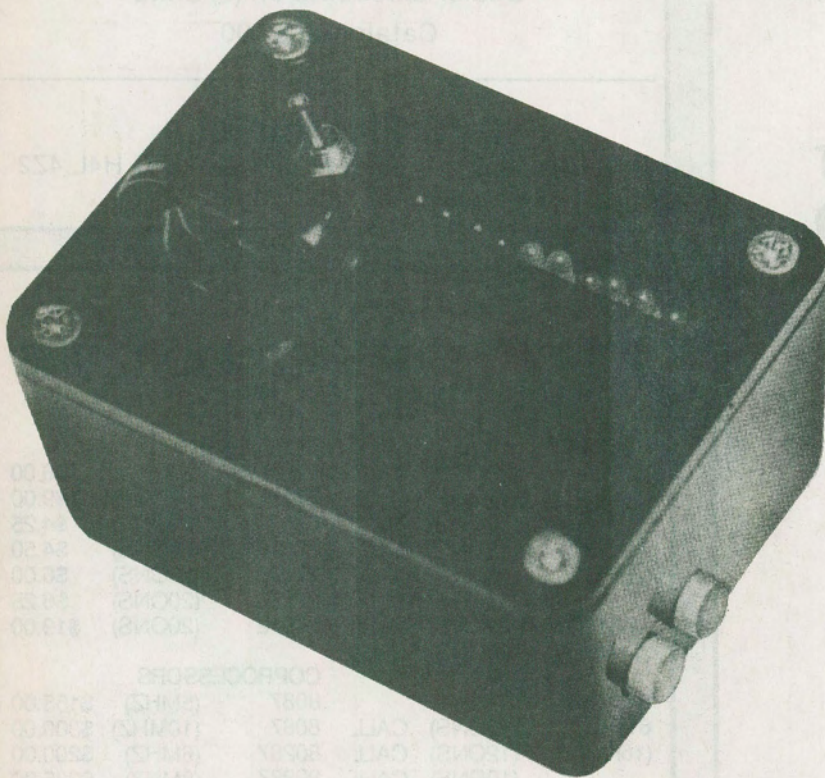

It is well known that a person's skin resistance varies with the emotional state. For example, many readers will have experienced wet hands while waiting to see the dentist. It is this moisture, together with the presence of salt, which reduces the skin resistance. It may be easily measured using an ohmmeter with one probe held in each hand. A typical "dry" resistance is 200k ohms, but with wet hands it may fall to 10k ohm or less. This effect is used in the "polygraph" or lie-detector. Here, changes in skin resistance cause pens to trace graphs on a moving paper roll. From the appearance of these traces, an expert operator can judge, with debatable accuracy, whether or not the subject is lying.

This battery-operated device is much simpler than a professional polygraph, and then some. The subject holds a pair of electrodes and a row of ten LEDs glow, thermometer fashion, according to the skin resistance. It makes no pretence to accuracy — indeed, considerable training is needed to obtain reliable results from any type of lie detector. However, it is good enough for entertainment and may be used either in its own right or in games where the detection of a lie might prove helpful to an opponent, but don't bet the rent on this one.

## Circuit Description

The circuit for the Lie Detector is shown in Fig. 1. The principle component is the bar driver IC1. This accepts an analogue voltage at the input, pin 5, and lights one of a row of ten LEDs connected to the outputs (pins 1 and 10 to 18) according to the voltage level.

The skin resistance, together with resistor R2 and potentiometer VR1, form a potential divider across the supply so a voltage appears at pin 5 whose value increases as skin resistance falls. This operates the IC in the manner described. VR1 sets the operating range and resistor R1 determines the LED operating current and hence their brightness.

Capacitor C1 prevents possible erratic behaviour caused by AC hum pick-up and also serves to slow down the response time. Resistor R2 prevents a short-circuit to the supply if the electrodes are allowed to touch while VR1 is set to minimum. The circuit is battery operated and so safe in use. On no account should it be converted to AC operation or an AC power supply used, or your first lie will be your last. The current requirement is about 20mA so the internal battery will give excellent service.

## Construction

Most of the components are mounted on a circuit panel consisting of a piece of 0.1in. perf-board or Veroboard. Make all breaks in the copper strips as shown and insert the inter-strip links.

Mount the soldered components as indicated

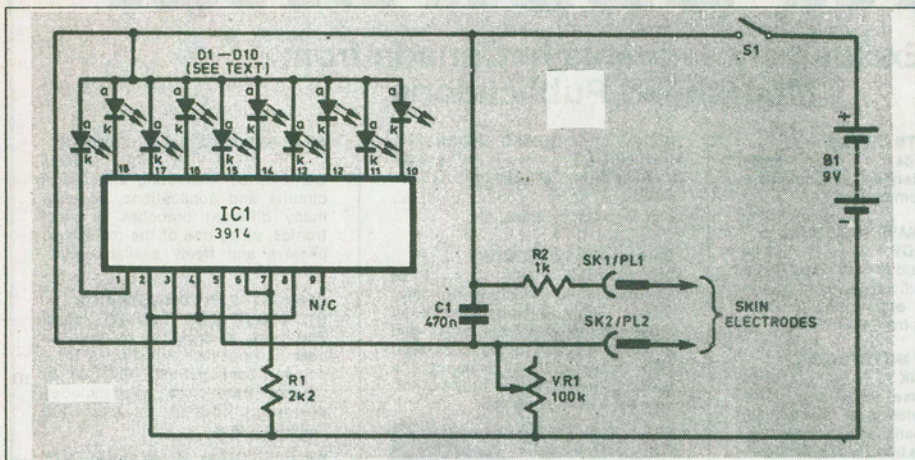

Fig. 1. Complete circuit diagram for the Lie Detector.

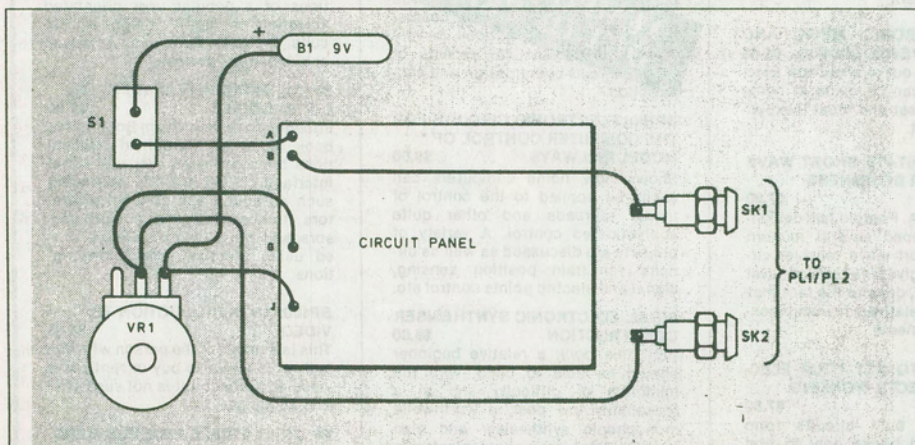

Fig. 3. Interwiring from board to case-mounted components.

but do not insert the IC into its holder until the end of construction. Pay particular attention to the polarity of the LEDs and when soldering them in position, note that the wire ends must be bent gently so that the array occupies the whole width of the circuit panel.

Also, take care to ensure that all LEDs reach the same height. In the prototype unit, D1 to D4 were red, D5 and D6 yellow and D7 to D10 green. This adds to the fun but they could all be the same colour if desired. Solder 10 cm. pieces of light-duty stranded connecting wire to each of strips A, B, G and J as indicated.

Drill holes in the case of S1, VR1 and for the sockets. Cut a slot in the lid size 3mm x 40mm for the LED display. Mount the remaining components and complete all wiring as shown in Fig. 3. Without touching the pins, remove the IC from its special packing and insert it into its socket. This precaution is necessary since IC1 is a CMOS device and therefore liable to be damaged by static charge.

Fit the battery and secure the circuit panel with the LEDs occupying the slot in

the lid. An adhesive fixing pad applied to the top of IC1 will serve this purpose. Attach the battery to the base of the box with a similar pad.

### Electrodes

The choice of electrodes is left to the constructor and may be the subject of experiment. One may be held in each hand or they may be combined for single-handed operation. In two-handed use, response depends largely on the pressure which the subject exerts on the electrodes. This may be seen as an advantage since a nervous person will tend to grip them more tightly.

On the other hand, a combination electrode responds mainly to the presence of moisture. Such a device may be made from a piece of stripboard with adjacent copper tracks jointed together (see Fig. 4). It may be taped to the subject's palm with the copper strips touching the skin. Light-duty twin wire connects the electrodes to SK1 and SK2 on the unit.

### Operation

Arrange the electrodes and switch on. Ad-

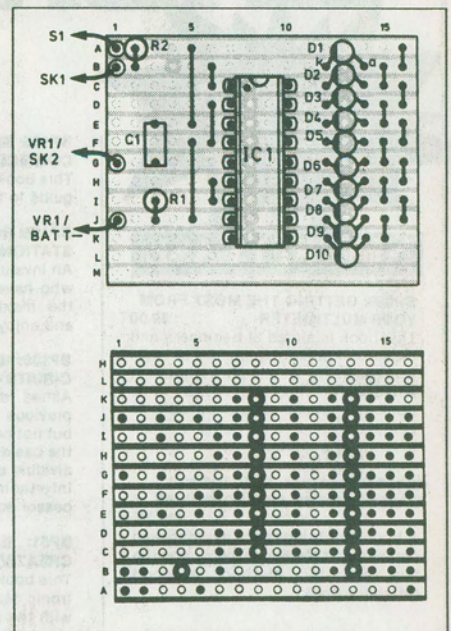

Fig. 2. Component layout.

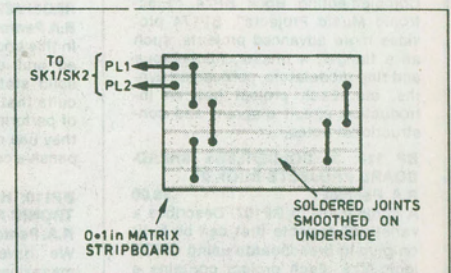

Fig. 4. Combination skin sensor electrode.

## PARTS LIST

### Resistors

R1	.....	2k2
R2	.....	1k
Both 0.25W 5% carbon		

### Potentiometer

VR1	.....	100k min.
-----	-------	-----------

### Capacitor

C1	.....	470n
----	-------	------

### Semiconductors

IC1	LM3914N linear bar driver
D1-D10	3mm LEDs: red (4), yellow (2), green (4), (or 10 red)

### Miscellaneous

Plastic case, 0.1in. Veroboard, 13 strips by 16 holes; S1 sub-miniature SPST toggle switch; pointer knob, plugs and sockets; 9V battery and connector; electrode materials (see text).

just VR1 for the required range of operation. Decreases in skin resistance will now cause the LEDs to glow in turn. Although the Lie Detector is great fun to use, the results should not be taken too seriously. ■