WIND FARM – TECHNICAL REGULATIONS, POTENTIAL ESTIMATION AND SITING ASSESSMENT

Edited by **Gastón Orlando Suvire**

INTECHWEB.ORG

Wind Farm – Technical Regulations, Potential Estimation and Siting Assessment

Edited by Gastón Orlando Suvire

Published by InTech

Janeza Trdine 9, 51000 Rijeka, Croatia

Copyright © 2011 InTech

All chapters are Open Access articles distributed under the Creative Commons Non Commercial Share Alike Attribution 3.0 license, which permits to copy, distribute, transmit, and adapt the work in any medium, so long as the original work is properly cited. After this work has been published by InTech, authors have the right to republish it, in whole or part, in any publication of which they are the author, and to make other personal use of the work. Any republication, referencing or personal use of the work must explicitly identify the original source.

Statements and opinions expressed in the chapters are these of the individual contributors and not necessarily those of the editors or publisher. No responsibility is accepted for the accuracy of information contained in the published articles. The publisher assumes no responsibility for any damage or injury to persons or property arising out of the use of any materials, instructions, methods or ideas contained in the book.

Publishing Process Manager Romina Krebel

Technical Editor Teodora Smiljanic

Cover Designer Jan Hyrat

Image Copyright maggee, 2010. Used under license from Shutterstock.com

First published July, 2011

Printed in Croatia

A free online edition of this book is available at www.intechopen.com
Additional hard copies can be obtained from orders@intechweb.org

Wind Farm – Technical Regulations, Potential Estimation and Siting Assessment,

Edited by Gastón Orlando Suvire

p. cm.

ISBN 978-953-307-483-2

INTECH OPEN ACCESS
PUBLISHER

INTECH open

free online editions of InTech
Books and Journals can be found at
www.intechopen.com

Contents

Preface IX

Part 1 Technical Regulations and Costs of Wind Power Generation 1

Chapter 1 **Technical and Regulatory Exigencies
for Grid Connection of Wind Generation 3**
Marcelo Gustavo Molina and Juan Manuel Gimenez Alvarez

Chapter 2 **O&M Cost Estimation & Feedback
of Operational Data 31**
Tom Obdam, Henk Braam, René van de Pieterman
and Luc Rademakers

Chapter 3 **Community Wind Power –
A Tipping Point Strategy for Driving Socio-Economic
Revitalization in Detroit and Southeast Michigan 65**
Daniel Bral, Caisheng Wang and Chih-Ping Yeh

Part 2 Potential Estimation and Impact on the Environment of Wind Farms 95

Chapter 4 **Methodologies Used in the Extrapolation
of Wind Speed Data at Different Heights
and Its Impact in the Wind Energy Resource
Assessment in a Region 97**
Francisco Bañuelos-Ruedas, César Ángeles Camacho
and Sebastián Rios-Marcuello

Chapter 5 **Wind Energy Assessment
of the Sidi Daoud Wind Farm - Tunisia 115**
F. Ben Amar and M. Elamouri

Chapter 6 **Wind Farms and Their Impact
on the Environment 141**
Vladimír Lapčík

Part 3 Siting Assessment of Wind Farms 163

- Chapter 7 **Advanced Wind Resource Characterization and Stationarity Analysis for Improved Wind Farm Siting 165**
Scott Greene and Mark Morrissey
- Chapter 8 **Spatial Diversification of Wind Farms: System Reliability and Private Incentives 175**
Christopher M. Worley and Daniel T. Kaffine
- Chapter 9 **Geotechnical and Geophysical Studies for Wind Farms in Earthquake Prone Areas 191**
Ferhat Ozcep, Mehmet Guzel and Savas Karabulut
- Chapter 10 **A Holistic Approach for Wind Farm Site Selection by FAHP 213**
Ilhan Talinli, Emel Topuz, Egemen Aydin and Sibel B. Kabakci

Preface

Wind power generation is considered as the most economic viable alternative within the portfolio of renewable energy resources. Among their advantages are the large number of potential sites for erection and the rapidly evolving technology with many suppliers offering from the individual turbine set to even turnkey projects. The disadvantages of wind energy include high capital costs and lack of controllability on the discontinuous or intermittent resource. However, the evolution of wind power generation is being produced with a very high growth rate at world level (around 30%). This growth, together with the foreseeable installation of many wind farms in a near future, forces the utilities to evaluate diverse aspects of the integration of wind power generation in the power systems.

This book addresses a wide variety of issues regarding the integration of wind farms in power systems, from technical regulations to siting assessment. The book is the results of contributions from many researchers worldwide. I hope that the book will become a useful source of information and basis for discussion for the readers. I wish to thank all chapter authors for their efforts and the quality of the material submitted.

The book contains 10 chapters divided into three parts, grouped by different themes. The first part (Chapters 1 to 3) outlines aspects related to technical regulations and costs of wind farms. In the second part (Chapters 4 to 6), the potential estimation and the impact on the environment of wind energy project are presented. Finally, the third part (Chapters 7 to 10) covers issues of the siting assessment of wind farms. A brief description of each chapter is presented below.

In Chapter 1 of the book, a revision of wind generation is presented, including a brief history of the wind energy developments, some remarks related to the modern wind energy systems, a survey of modern structures of wind turbines, major wind turbine concepts related to fixed and variable speed operation and control modes, and technical and regulatory exigencies for the integration of wind generation into the electrical grid, including a study of selected countries grid codes.

In Chapter 2, the whole approach of structured data collection, data analysis, and O&M cost estimation with the goal of increasing the accuracy and decreasing the uncertainties of O&M costs estimates is discussed.

Chapter 3 introduces the concept of Community Based Wind Power as a test bed solution to couple electric power generation with social and community development initiatives. The idea of this concept is to provide individuals within a community with an alternative model for the provision of their electric energy as well as socio-economic needs.

Chapter 4 is aimed at presenting the impact of various methods and models used for extrapolating wind speed measurements and generate a relevant wind speed profile. The results are compared against the real life wind speed readings. Wind resource maps come as a plus factor.

In Chapter 5, a meteorological and energetic study of the Sidi Daoud wind power station installed in Tunisia is presented. Based on the meteorological data recorded, the wind potential of the Sidi Daoud site has been evaluated by the meteorological method and the Weibull and Rayleigh analytical methods.

Chapter 6 summarizes author's experience with environmental impact assessment of wind farms. The chapter deals with experience with environmental impacts of wind farms and implementation of the environmental impact assessment process in the field of wind power in the Czech Republic.

Chapter 7 discusses statistical methods to identify potential sites for wind power projects, outlining the state of the art in understanding the wind resource, and discussing the strengths and weaknesses of existing methods.

Chapter 8 develops a simple theoretical model to compare the optimal siting decisions of individual wind developers versus the optimal siting decisions of system operators.

In Chapter 9, geotechnical and geophysical studies for wind farms in earthquake prone areas are investigated.

Finally, Chapter 10 aims to apply the fuzzy analytic hierarchy process (FAHP) to find priority sequence of alternatives and obtain the key success factors for the selection of appropriate sites of wind farms.

Gastón O. Suvire
Instituto de Energía Eléctrica
Facultad de Ingeniería
Universidad Nacional de San Juan
Argentina

Part 1

Technical Regulations and Costs of Wind Power Generation

Technical and Regulatory Exigencies for Grid Connection of Wind Generation

Marcelo Gustavo Molina¹ and Juan Manuel Gimenez Alvarez²

¹CONICET, Instituto de Energía Eléctrica, Universidad Nacional de San Juan

²CONICET, Depto. de Ingeniería Electromecánica, Universidad Nacional de San Juan
Argentina

1. Introduction

Pollution problems such as the greenhouse effect as well as the high value and volatility of fuel prices have forced and accelerated the development and use of renewable energy sources. In the three last decades, the level of penetration of renewable energy sources has undergone an important growth in several countries, mainly in the USA and Europe, where levels of 20% have been reached. Main technologies of renewable energies include wind, hydraulic, solar (photovoltaic and thermal), biofuels (liquid biodiesel, biomass, biogas), and geothermal energy. Within this great variety of alternative energy sources, wind energy has experienced a fast growth due to several advantages, such as costs, feasibility, abundance of wind resources, maturity of the technology and shorter construction times (Ackermann, 2005). This trend is expected to be increased even more in the near future, sustained mainly by the cost competitiveness of wind power technology and the development of new power electronics technologies, new circuit topologies and control strategies (Guerrero et al., 2010). However, there are some disadvantages for wind energy, as wind generation is uncontrollably variable because of the intermittency of the primary resource, i.e. the wind. Another important disadvantage is that the best places to install a wind farm, due to the certainty and intensities of suitable wind, are located in remote areas. This aspect requires of additional infrastructure to convey the generated power to the demand centres. Unfortunately, in several countries the regulatory aspect does not follow this fast growth of wind possibilities. Many countries do not have specific rules for wind generators and others do not make the necessary operating studies before installing a wind farm (Heier, 2006). Power system operators must consider the availability of these power plants which are not dispatchable and are not accessible all the time. Today, developing countries, such as Argentina, are subjected to an analogous situation with wind energy, having perhaps one of the best sources of such energy around the world. Nowadays, there are several operative wind farms and others in stage of building and planning. Similar to other countries, in Argentina there is a lack of regulatory aspects related to this topic (Labriola, 2007). This chapter thoroughly presents a revision of wind generation, including the following sections. In the first part, a brief history of the wind energy developments is presented. Following, some remarks related to the modern wind energy systems are made. Then, a survey of modern structures of wind turbines is carried out, including towers and foundations, rotor, nacelle with drive train and other equipment, control systems, etc.

Subsequently, major wind turbine concepts related to fixed and variable speed operation and control modes are described. Eventually, technical and regulatory exigencies for the integration of wind generation into the electrical grid are discussed in detail, including a study of selected countries grid codes.

2. Overview of wind energy technology

2.1 A brief history of wind energy development

Since ancient times, man has harnessed the power of the wind for a variety of tasks. Indeed, humans have been using wind energy in their daily work for some 4 000 years. In 1700 B.C., King Hammurabi of Babylon used wind powered scoops to irrigate Mesopotamia. Some other civilizations, like the Persians (500–900 A.D.), used the wind to grind grain into flour, while others used the wind to transport armies and goods across oceans and rivers. Sails revolutionized seafaring, which no longer had to be done with muscle power. More recently, mankind has used the power of the wind to pump water and produce electricity. So the idea of using wind, a natural source, is not new (Rahman, 2003).

The discovery of electricity generated using wind power dates back to the end of last century and has encountered many ups and downs in its more than 100 year history. In the beginning, the primary motivation for essentially all the researches on wind power generation was to reinforce the mechanization of agriculture through locally-made electricity generation. Nevertheless, with the electrification of industrialized countries, the role of wind power was drastically reduced, as it could not compete with the fossil fuel-fired power stations. This conventional generation showed to be by far more competitive in providing electric power on a large scale than any other renewable one.

Lack of fossil fuels during World War I and soon afterward during World War II created a consciousness of the great dependence on fossil fuels and gave a renewed attention to renewable energies and particularly to wind power. Although this concern did not extend for a long time. The prices for electricity generated via wind power were still not competitive and politically nuclear power gained more attention and hence more research and development funds. It took two oil crises in the 1970s with supply problems and price fluctuations on fossil fuels before wind power once again was placed on the agenda. And they were these issues confronting many countries in the seventies which started a new stage for wind power and motivated the development of a global industry which today is characterized by relatively few but very large wind turbine manufacturers (Vestergaard et al., 2004).

Wind turbines that generate electricity today are new and innovative. Their successful history began with a few technical innovations, such as the use of synthetic materials to build rotor blades, and continued with developments in the field of aerodynamics, mechanical/electrical engineering, control technology, and electronics provide the technical basis for wind turbines commonly used today. Since 1980, wind power has been the fastest growing energy technology in the world.

2.2 Modern wind energy systems

The beginning of modern wind turbine development was in 1957, marked by the Danish engineer Johannes Juul and his pioneer work at a power utility (SEAS at Gedser coast in the Southern part of Denmark). His R&D effort formed the basis for the design of a modern AC wind turbine – the well-known Gedser machine which was successfully installed in 1959.

With its 200kW capacity, the Gedser wind turbine was the largest of its kind in the world at that time and it was in operation for 11 years without maintenance. The robust Gedser wind turbine was a technological innovation as it became the hall mark of modern design of wind turbines with three wings, tip brakes, self-regulating and an asynchronous motor as generator. Foreign engineers named the Gedser wind turbine as 'The Danish Concept' (Chen & Blaabjerg, 2009).

Since then, the main aerodynamic concept has been this horizontal axis, three-bladed, upwind wind turbine connected to a three-phase electric grid, although many other different concepts have been developed and tested over the world with dissimilar results. An example of other concepts is the vertical axis wind turbine design by Darrieus, which provides a different mix of design tradeoffs from the conventional horizontal-axis wind turbine. The vertical orientation accepts wind from any direction with no need for adjustments, and the heavy generator and gearbox equipment can rest on the ground instead of on top of the tower (Molina & Mercado 2011).

The aim of wind turbine systems development is to continuously increase output power. Since the rated output power of production-type units reached 200 kW various decades ago, by 1999 the average output power of new installations climbed to 600 kW. Today, the manufactured turbines for onshore applications are specified to deliver 2-3 MW output power. In this sense, the world's first wind park with novel "multi-mega power class" 7 MW wind turbines was manufactured by the German wind turbine producer Enercon (11 E-126 units) and put into partial operation in Estinnes, Belgium, in 2010 (to be completed by July 2012). The key objective of this 77 MW pilot project is to introduce a new power class of large-scale wind energy converters (7 MW WECs) into the market with potential to significantly contribute to higher market penetration levels for wind electricity, especially in Europe. On the other hand, sea-based wind farms are likely to mean bigger turbines than on land, with models that produce up to three times power of standard on-shore models. Series production of offshore wind turbines can reach to date up to 5 MW or more, being the largest onshore wind turbine presently under development a 10 MW unit. At least four companies are working on the development of this "giant power class" 10 MW turbine for sea-based applications, namely American Superconductors (U.S.), Wind Power (U.K.), Clipper Windpower (U.K.) and Sway (Norway). Even more, it is likely that in the near future, power rating of wind turbines will increase further, especially for large-scale offshore floating wind turbine applications.

3. Structure of modern wind turbines

Basically, a wind energy conversion system consists of a turbine tower which carries the nacelle, and the wind turbine rotor, consisting of rotor blades and hub. Most modern wind turbines are horizontal-axis wind turbines (HAWTs) with three rotor blades usually placed upwind of the tower and the nacelle, as illustrated in Fig. 1 (Molina & Mercado, 2011). On the outside, the nacelle is usually equipped with anemometers and a wind vane to measure the wind speed and direction, as well as with aviation lights. The nacelle contains the key components of the wind turbine, i.e. the gearbox, mechanical brake, electrical generator, control systems, yaw drive, etc. The wind turbines are not only installed dispersedly on land, but also combined as wind farms (or parks) with capacities of hundreds MWs which are comparable with modern power generator units.

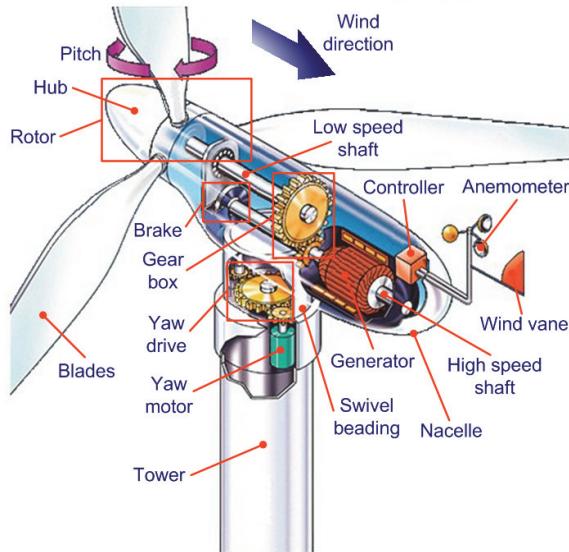

Fig. 1. Major components of a typical horizontal axis, three-bladed, upwind wind turbine

Of the various wind turbine models found around the world, most operate in a similar way and have components that serve very similar functions. Based on this feature, major components that most wind turbines have in common are described below.

3.1 Tower and foundation

One of the most important pieces of the wind turbine assembly is the tower that it is mounted upon. Mounting a wind turbine on the highest possible tower results in increased power production due to the stronger winds present at higher altitudes. In addition, the effects of the wind shear caused by the surrounding terrain is also much less at higher altitudes, providing yet another reason to mount the turbine as high as possible.

Of course, there are some limitations as to how tall of a tower is appropriate for a given application. One such consideration is the structural requirement necessary to support the turbine being considered, included how much the turbine weighs as well as what types of environmental forces (high winds, snow, rain) it will have to sustain over time. Zoning regulations may also play a role in dictating the maximum allowable height that the turbine assembly may be elevated off the ground (Villalobos Jara, 2009).

There are many different types of towers available for a wide variety of turbine sizes. One of the primary categories is the Lattice Tower which is essentially a very narrow, pyramid shaped structure that is strengthened with trusses. Towers of this variety may be self-supporting or they can be further supported by wires.

The other predominant type of tower is the monopole tower. This type of tower consists of a single pole that supports the turbine. As it is expected, lattice towers are much sturdier and can therefore elevate wind turbines to much greater heights than the monopole tower. However, the lattice towers also require more ground space for their larger footprint than what is necessary for a monopole tower. As a result, there is seemingly a tradeoff between strength and the amount of land consumed by the tower foundation. This was true up until

the advent of the now traditional tube tower. As strong, if not stronger, than a lattice tower, the tube tower takes up not much more land than a monopole tower. Due to its immense foundation, located almost entirely underground, tube towers are extremely sturdy structures that can withstand the strongest forces. While not possible until today's modern manufacturing and engineering practices, tube towers have engulfed the entire wind industry and it is rare to see a turbine of any appreciable size erected that is not sited on a tube tower.

The design of the wind turbine foundation in order to guarantee its stability at all operating conditions depends not only of the consistency of the underlying ground but also of the changing weather conditions (e.g. expanse and depth of permafrost in polar regions and where ice is prevalent) to support weight, plus huge static loads and variable forces exerted by the rotating turbine is extremely challenging. Tower foundations must not settle, tilt or be uplifted. Pile foundations may extend $1/3$ to $2/3$ the height of the tower into the ground. This requires thorough geotechnical research and testing to assess the ground conditions at the site to determine foundation design recommendations.

Offshore wind turbine foundation design requires development of highly cost effective concepts, because the share of the cost of the foundation relative to that of the complete wind turbine installation is considerably higher than that of an onshore foundation. Further, environmental and energy gain considerations require of wind farms to be located farther from shore at consequently deeper waters (Villalobos Jara, 2009). With this trend of ever larger turbines in deeper and rougher waters, the design and construction challenges and complexity increase proportionally, and both become closer to or beyond normal experience. Hence, value engineering becomes crucial for development of foundation concepts that are sufficiently robust to be carried through to site installation without impacting the economic viability of the projects.

3.2 Rotor

The rotor is the heart of a wind turbine and consists of multiple rotor blades attached to a hub. It is the turbine component responsible for collecting the energy present in the wind and transforming this energy into mechanical motion. As the overall diameter of the rotor design increases, the amount of energy that the rotor can extract from the wind increases as well. Therefore, turbines are often designed around a certain diameter rotor and the predicted energy that can be drawn from the wind.

The predominant aerodynamic principles that rotor designs are based upon are Drag Design and Lift Design. Drag design rotors operate on the idea of the wind "pushing" the blades out of the way, thereby setting the rotor into motion. Drag design rotors have slower rotational speeds but high-torque capabilities, making them ideal for pumping applications. With Lift design rotors, the blades are designed to function like the wing of an airplane. Each blade is designed as an airfoil, creating lift as the wind moves past the blades. The airfoil operates on the basis of Bernoulli's Principle where the shape of the blade causes a pressure differential between its upper and lower surfaces. This disparity in pressure causes an upward force that lifts the airfoil. In this case, this lift causes the rotor to rotate, once again transforming the energy in the wind into mechanical motion.

In the following, the structure and operation of rotors are discussed and concepts of power control presented (Freris, 1990; Stiesdal, 1999; Thomsen et al., 2007).

3.2.1 Rotor blades

Rotor blades are a crucial and basic part of a wind turbine. The design of the individual blades also affects the overall design of the rotor. Various strains are placed on them, and they must withstand very big loads. Rotor blades take the energy out of the wind; they “capture” the wind and convert its kinetic energy into the rotation of the hub. The profile is similar to that of airplane wings. Rotor blades utilize the same “lift” principle: below the wing, the stream of air produces overpressure; above the wing, the stream of air produces vacuum. These forces make the rotor rotate. Today, most rotors have three blades, a horizontal axis, and a diameter of between 40 and 90 meters. In addition to the currently popular three-blade rotor, two-blade rotors are also used to be common in addition to rotors with many blades, such as the traditional wind mills with 20 to 30 metal blades that pump water. Over time, it was found that three-blade rotor is the most efficient for power generation by large wind turbines.

In addition, the use of three rotor blades allows for a better distribution of mass, which makes rotation smoother and also provides for a “calmer” appearance. The rotor blades mainly consist of synthetic materials reinforced with fiberglass and carbon fibers. The layers are usually glued together with epoxy resin. Wood, wood epoxy and wood-fiber-epoxy compounds are less widely used. One of the main benefits of wooden rotor blades is that they can be recycled. Aluminum and steel alloys are heavier and suffer from material fatigue. These materials are therefore generally only used for very small wind turbines. Each manufacturer has its own rotor blade concepts and conducts research on innovative designs. In general, though, all rotor blades are constructed similarly to airplane wings.

3.2.2 Hub

The hub is the centre of the rotor to which the rotor blades are attached. Cast iron or cast steel is most often used. The hub directs the energy from the rotor blades on to the generator. If the wind turbines have a gearbox, the hub is connected to the slowly rotating gearbox shaft, converting the energy from the wind into rotation energy. If the turbine has a direct drive, the hub passes the energy directly on to the generator. The rotor blade can be attached to the hub in various ways: either in a fixed position, with an articulation, or as a pendulum. The latter is a special version of the two-blade rotor, which swings as a pendulum anchored to the hub. Most manufacturers nowadays use a fixed hub. It has proved to be sturdy, reduces the number of movable components that can fail, and is relatively easy to build.

3.2.3 Power control of the wind turbine

Wind turbines are generally designed to yield maximum power (nominal capacity) at a rated (or nominal) wind speed in the range of 11–15 m/s (around 40–54 km/h, or nearly 25–34 mph) for most commercial units. It does not justify designing turbines that maximize their output at stronger winds, because such strong winds are rare.

In case of stronger winds it is necessary to waste part of the excess energy of the wind in order to ensure that a maximum constant level of power is fed to the grid and thus avoids damaging the wind turbine.

Wind turbines begin generating power at the cut-on speed of around 2.5–4 m/s (about 9–14 km/h, or almost 6–9 mph) and cut off at wind speed of 25–34 m/s (around 90–122 km/h, or nearly 56–76 mph). The maximum wind speed (or survival speed), above which wind

turbines are destroyed, is in the range of 40–72 m/s (144–259 km/h, or 89–161 mph). The most common survival speed of commercial wind turbines is around 60 m/s (216 km/h or 134 mph).

Wind turbines have three modes of operation (Hansen et al., 2004.):

- Below rated wind speed operation
- Around rated wind speed operation (usually at nominal capacity)
- Above rated wind speed operation

If the rated wind speed is exceeded the power has to be limited. Therefore, all wind turbines are designed with a power control that achieves this goal and avoids a run-away situation. There are different ways of doing this safely on modern turbines, namely mainly pitch control and stall control.

3.2.3.1 Pitch control

This control concept was developed between years 1990 and 2000 and operates by turning the rotor blades into or out of the wind according to the control laws. An anemometer mounted atop the nacelle constantly checks the wind speed and sends signals to the pitch actuator, adjusting the angle of the blades to capture the energy from the wind most efficiently.

Standard modern turbines usually pitch the blades at high winds in order to prevent the rotational speed from rising to an unacceptably dangerous level. Since pitching requires acting against the torque on the blade, it requires some form of pitch angle control, which is achieved with a slewing drive. This drive precisely angles the blade while withstanding high torque loads. In addition, many turbines use hydraulic systems. These systems are usually spring loaded, so that if hydraulic power fails, the blades automatically furl. Other turbines use an electric servomotor for every rotor blade. They have a small battery-reserve in case of an electric grid breakdown. Small wind turbines (fewer than some kW) with variable pitching generally use systems operated by centrifugal force, either by flyweights or geometric design, and employ no electric or hydraulic controls.

In a pitch controlled wind turbine, the electronic controller checks the power output of the turbine several times per second. When the power output becomes too high, it sends an order to the blade pitch mechanism which immediately pitches (turns) the rotor blades slightly out of the wind. On the other hand, the blades are turned back into the wind whenever the wind drops again. The rotor blades thus have to be able to turn around their longitudinal axis (to pitch).

During normal operation (below or around rated wind speed) the controller generally pitches the blades a few degrees every time the wind changes in order to keep the rotor blades at the optimum angle in order to maximize output at all wind speeds.

3.2.3.2 Stall control

In a stall-regulated wind turbine, the blades are locked in place and do not adjust during operation. Instead the blades are aerodynamically designed and shaped to increasingly “stall” the blade angle of attack with the wind to both maximize power output and protect the turbine from excessive wind speeds. As the actual wind speed in the rotor area increases the angle of attack of the rotor blade also increases, until at some point it starts to stall. Thus, it is ensured that at the moment the wind speed becomes too high, it creates turbulence on the side of the rotor blade which is not facing the wind and prevents the lifting force of the rotor blade from acting on the rotor.

Stalling works by increasing the angle at which the relative wind strikes the blades (angle of attack), and it reduces the induced drag (drag associated with lift). Stalling is simple because it can be made to happen passively (it increases automatically when the winds speed up), or actively (the rotor blade angle is adjusted or pitched in order to create stall along the blades). Active stall regulation allows for power to be regulated more accurately than passive stall regulation does.

The main advantage of stall control is that it avoids moving parts in the rotor itself, and therefore a complex control system since they do not have the same level of mechanical and operational complexity as pitch-regulated turbines. In this way, stall-regulated turbines are often considered more reliable than pitch-regulated ones. On the other hand, stall control represents a very complex aerodynamic design problem, and related design challenges in the structural dynamics of the whole wind turbine, e.g. to avoid stall-induced vibrations. In addition, pitch-regulated wind turbines are generally considered to be slightly more efficient than stall-regulated ones. Around two thirds of the wind turbines currently being installed in the world are stall controlled machines.

3.2.3.3 Other power control methods

Some older wind turbines use ailerons (flaps) to control the power of the rotor, just like aircraft use flaps to alter the geometry of the wings to provide extra lift at takeoff. Another possibility is to yaw the rotor partly out of the wind to decrease power. This technique of yaw control is in practice used only for tiny wind turbines (1 kW or less), as it subjects the rotor to cyclically varying stress which may ultimately damage the entire structure. Braking of a small wind turbine can also be done by dumping energy from the generator into a resistor bank, converting the kinetic energy of the turbine rotation into heat. This method is useful if the kinetic load on the generator is suddenly reduced or is too small to keep the turbine speed within its allowed limit. Cyclically, braking causes the blades to slow down, which increases the stalling effect, reducing the efficiency of the blades. In this way, the turbine rotation can be kept at a safe speed in faster winds while maintaining (nominal) power output. This technique is also used only for tiny wind turbines and cannot be applied for large wind turbines.

3.3 Nacelle with drive train and other equipment

The nacelle contains all the machinery of the wind turbine, i.e. the drive train including the mechanical transmission (rotor shaft, bearings and the gearbox) and the electrical generator, and other equipment such as the power electronic interface, the yaw drive, the mechanical brake, and the control system, among others. Because it requires rotating in order to track the wind direction, it is connected to the tower via bearings. The build-up of the nacelle shows how the manufacturer has decided to place the drive train and other components above this machine bearing.

3.3.1 Drive train

3.3.1.1 Mechanical transmission

The gearbox is the major component of the mechanical transmission. Due to their huge diameters, the rotors of large scale wind turbines tend to have very slow rotational speeds (generally 18–50 rpm). In most cases, these speeds are insufficient to operate their generators at maximum efficiency (for most generators, somewhere in the range of 1200–1800 rpm).

The solution is to include a gearbox transmission between the rotor output shaft and the generator input shaft so that the rotor speed can be geared up to the appropriate rpm required by the generator for maximum power generation. In the case of multi-pole synchronous generators coupled to the electric grid via a full scale power converter, which decouples entirely the generator system from the utility grid, since it can operate at low speeds the gearbox can be omitted. Consequently, a gearless construction represents an efficient and robust solution that is beneficial, especially for offshore applications, where low maintenance requirements are essential. In the case of wind turbines with smaller rotor diameters, the gearbox transmission between the rotor and generator can be also omitted. A decrease in rotor diameter results in a smaller arc-length that the rotor must travel per revolution, eventually causing a comparatively larger rotational speed than that of a larger rotor for a given wind speed. If these larger rotational speeds are appropriate for the type of generator being used, the rotor can be connected straightforwardly to the generator resulting in a direct-driven system in the same way as in the system linked with the power converter. These smaller direct-driven wind turbine systems are predominately used in stand-alone (not grid-connected) DC applications (battery charging, etc).

3.3.1.2 Electrical generator

The generator is the component of the wind turbine responsible for converting the mechanical motion of the rotor into electrical energy. The blades transfer the kinetic energy from the wind into rotational energy in the transmission system, and the generator is the next step in the supply of energy from the wind turbine to the electrical grid.

There are many different types and sizes of electric generators for a wide range of applications. Depending on the size of the rotor and the amount of mechanical energy removed from the wind, a generator may be chosen to produce either AC or DC voltage over a variety of power outputs.

There are two major types of electrical generators for converting mechanical energy. The first is the synchronous generator. The synchronous generator operates on the principle that as a magnet is rotated in the presence of a coil of wire, the changing magnetic field in space induces a current, and therefore a voltage in the coil of wire. In this case, the magnet is attached to the input shaft of the generator and is surrounded by several coils of wire, individually referred to as a pole. As the shaft rotates, so does the permanent magnet which creates a changing magnetic field in the presence of the poles which surround it. This induces a current in each of these poles and electrical energy is produced. Synchronous generators are typically quite simple and can be used in a wide variety of applications.

The second type is the asynchronous generator. At the heart of this design is its rotor, which is essentially a cylindrical cage of copper or aluminium bars that concentrically surround an iron core. This rotor construction looks a bit like a squirrel cage, and accordingly the asynchronous generator is also called a squirrel cage generator. Once again, this rotor is surrounded by a series of poles on its periphery called the stator. One way in which the asynchronous generator varies from the synchronous one is in that it is actually powered by the grid to set itself into motion initially. As the current from the grid passes through the stator, a current is induced in the cage rotor itself; causing opposing magnetic fields that set the rotor in motion at a specific rotational speed (this speed is determined by the frequency of the supply current and the number of poles in the stator). The generation of electricity occurs when the wind causes the rotational speed of the rotor to increase above this idle speed caused by the grid. What is fascinating about this phenomenon is that very large

voltages can be produced for comparatively small increases in rotational speed (considerable voltage for 10–15 rpm increase). With the rotor already in motion, there is little torque applied to the rotor shaft, ultimately resulting in less wear on the transmission. However, the asynchronous generator is much more complex than the synchronous one and also requires an initial source of power to operate. Asynchronous generators are more appropriate for applications where there is a fairly constant wind speed that rarely drops below a certain value.

3.3.2 Other equipment

3.3.2.1 Power electronic converter

Power electronic systems are used by many wind turbines as interfaces. Wind turbines function at variable rotational speed; thus the generator electric frequency varies and needs to be decoupled from the grid frequency through a power electronic converter system.

The power electronic converter enables wind turbines to operate at variable (or adjustable) speed, and thus permits to provide more effective power capture than the fixed-speed counterparts. In variable speed operation, a control system designed to extract maximum power from the wind turbine and to provide constant grid voltage and frequency is required according to the type of wind turbine used. With the advance of power electronics technology, this objective is easy to be accomplished, as will be noted from description of the subsequent section.

The power converter is an interface found between the load/generator and the grid. Depending on the topology and the applications present in the system, power can flow into the direction of both the generator and the grid. In using converters, three important things must be considered: reliability, efficiency, and cost.

Converters are made by power electronic devices, and circuits for driving, protection and control. Two different types of converter systems are currently in use: grid commutated and self commutated converters. Grid commutated converters are thyristor converters containing 6 or 12 pulse, or even more, that can produce integer harmonics. This kind of converter does not control the reactive power and consume inductive reactive power.

The other type of converter, self-commutated converter systems, are pulse width modulated (PWM) converters that mainly use Insulated Gate Bipolar Transistor (IGBTs). In contrast to grid-commutated, self-commutated converters control both active and reactive powers. PWM-converters, therefore, have the capacity to provide for the demand on reactive power and a high frequency switching that make them produce high harmonics and interharmonics.

3.3.2.2 Yaw drive

The yaw drive is an important component of modern horizontal axis wind turbines yaw system. To ensure the wind turbine is producing the maximum amount of electric energy at all times, the yaw drive is actively controlled to keep the rotor facing into the wind as the wind direction changes. This is accomplished by measured the wind direction by a wind vane situated on the back of the nacelle. The wind turbine is said to have a yaw angle (the misalignment between wind and turbine pointing direction) error if the rotor is not aligned to the wind. A yaw error implies that a lower share of the energy in the wind is running through the rotor area. The power – output losses are proportional to the cosine of the yaw error.

3.3.2.3 Mechanical brake

A wind turbine has two different types of brakes. One is the blade tip brake and the other is a mechanical (or stick) brake. The mechanical brake is placed on the small fast shaft between the gearbox and the generator. This mechanical drum brake or disk brake is only used as an emergency brake, if the blade tip brake fails. The brake is also used when the wind turbine is being repaired to eliminate any risk of the turbine suddenly starting. Such brakes are usually applied only after blade furling and electromagnetic braking have reduced the turbine speed, as the mechanical brakes would wear quickly if used to stop the turbine from full speed.

3.3.2.4 Control system

The wind turbine control system is involved in almost all decision-making processes in the safety of the wind turbine. At the same time, it must supervise the normal operation of the wind turbine and carry out the measurements for monitoring, control, statistical use, etc. The control system is usually based on a number of dedicated computers, specially designed for industrial use, which continuously monitor the condition of the wind turbine and collect statistics on its operation. As the name implies, the controller also controls a large number of switches, hydraulic pumps, valves, and motors within the wind turbine. As wind turbine sizes increase to megawatt machines, it becomes even more important that they have a high availability rate, i.e. that they function reliably all the time.

A series of sensors measure the conditions in the wind turbine. These sensors are usually employed for measuring temperature, wind direction, wind speed, rotational speed of the rotor, the generator, its voltage and current, and many other magnitudes can be found in and around the nacelle (somewhere between 100 and 500 parameter values are sensed in a modern wind turbine), and assist in the turbine control. Computers and sensors are usually duplicated (redundant) in all safety or operation sensitive areas of newer large machines. The controller continuously compares the readings from measurements throughout the wind turbine to ensure that both the sensors and the computers themselves are correctly operating.

4. Wind turbine concepts

Wind turbines can either be designed to operate at fixed speed (actually within a speed range about 1%) or at variable speed. Many low-power wind turbines built to-date were constructed according to the so-called "Danish concept" that was very popular in the 80s, in which wind energy is transformed into electrical energy using a simple squirrel-cage induction machine directly connected to a three-phase power grid (Qiao et al., 2007). The rotor of the wind turbine is coupled to the generator shaft with a fixed-ratio gearbox. At any given operating point, this turbine has to be operated basically at constant speed. On the other hand, modern high-power wind turbines in the 2-10 MW range are mainly based on variable speed operation with blade pitch angle control obtained mainly by means of power electronic equipment, although variable generator rotor resistance could also be used.

Variable speed wind turbine generators permits to provide more effective power capture than the fixed speed counterparts (Timbus et al., 2009). In fact, variable speed wind turbines have demonstrated to capture 8-15% more energy than constant speed machines. In variable speed operation, a control system designed to extract maximum power from the wind turbine and to provide constant grid voltage and frequency is required. As well as becoming

larger, wind turbine designs were progressing from fixed speed, stall-controlled and with drive trains with gear boxes to become pitch controlled, variable speed and with or without gearboxes.

Among variable speed wind turbines, direct-in-line systems and doubly-fed induction generator (DFIG) systems have increasingly drawn more interests to wind turbine manufactures due to their advantages over other variable speed wind turbines and currently have the most significant potential of growth (Molina & Mercado, 2011). Direct-in-line systems consists of a direct-driven (without gearbox) permanent magnet synchronous generator (PMSG) grid-connected via a full-scale power converter, while DFIG systems are built with a common induction generator with slip ring and a partial-scale converter connected to the rotor windings. Both modern pitch-controlled variable speed wind turbines technologies are emerging as the preferred technologies and have become the dominating type of yearly installed wind turbines in recent years (Blaabjerg & Chen, 2006).

4.1 Variable speed wind turbine with partial-scale power converter

This concept, aka doubly-fed induction generator (DFIG), corresponds to a variable speed controlled wind turbine with a wound rotor induction generator (WRIG) and a partial-scale power converter (rated approximately at 30% of nominal generated power) on the rotor circuit (Muller et al, 2002), as shown in Fig. 2. The use of power electronic converters enables wind turbines to operate at variable (or adjustable) speed, and thus permits to provide more effective power capture than the fixed-speed counterparts (Blaabjerg et al. 2004). In addition, other significant advantages using variable speed systems include a decrease in mechanical losses, which makes possible lighter mechanical designs, and a more controllable power output (less dependent on wind variations), cost-effectiveness, simple pitch control, improved power quality and system efficiency, reduced acoustic noise, and island-operation capability.

The rotor stator is directly connected to the electric grid, while a partial-scale power converter controls the rotor frequency and consequently the rotor speed. The partial-scale power converter is composed of a back-to-back four-quadrant AC/DC/AC converter design based on insulated gate bipolar transistors (IGBTs), whose power rating defines the speed range (typically around $\pm 30\%$ of the synchronous speed). Moreover, this converter allows controlling the reactive power compensation and a smooth grid connection (Carrasco et al., 2006). The partial-scale power converter makes this concept attractive from an economical point of view. However, its main drawbacks are the use of slip rings, which needs brushes and maintenance, and the complex protection schemes in the case of grid faults.

4.2 Direct-in-line variable speed wind turbine with full-scale power converter

This configuration corresponds to the direct-in-line full variable speed controlled wind turbine, with the generator connected to the electric grid through a full-scale power converter, as illustrated in Fig 3 (Li et al., 2009). A synchronous generator is used to produce variable frequency AC power. The power converter connected in series (or in-line) with the wind turbine generator transforms this variable frequency AC power into fixed-frequency AC power. This power converter also allows controlling the reactive power compensation locally generated, and a smooth grid connection for the entire speed range. The generator can be electrically excited (wound rotor synchronous generator, WRSG) or permanent magnet excited type (permanent magnet synchronous generator, PMSG). Recently, due to

the development in power electronics technology, the squirrel-cage induction generator (SCIG) has also started to be used for this concept. The generator stator is connected to the grid through a full-scale power converter, which is composed of a back-to-back four-quadrant AC/DC/AC converter design based on insulated gate bipolar transistors (IGBTs).

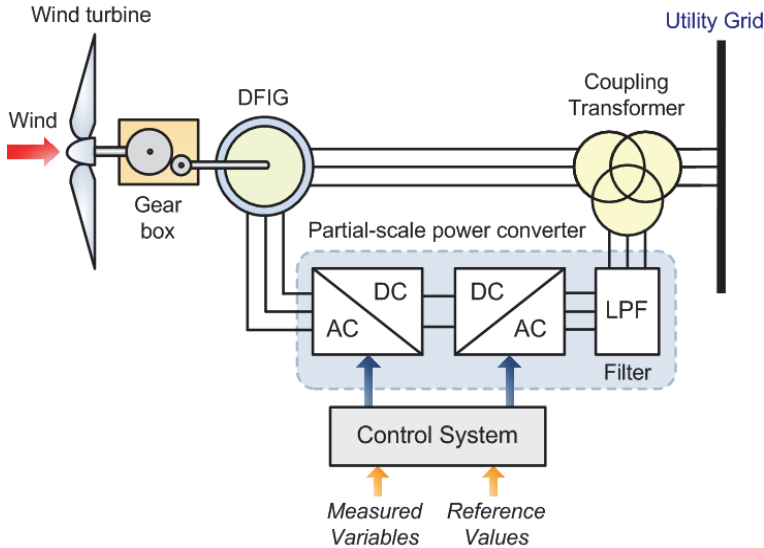

Fig. 2. Variable speed wind turbine with doubly-fed induction generator (DFIG) controlled with a partial-scale power converter

Some full variable speed wind turbine systems have no gearbox (shown in dotted lines in Fig. 3) and use a direct driven multi-pole generator.

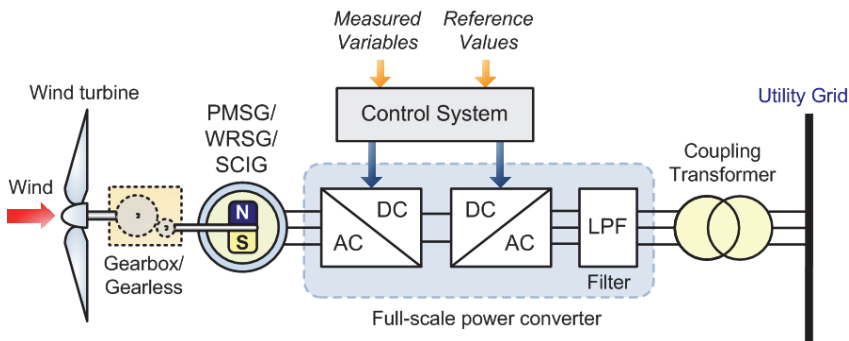

Fig. 3. Variable speed wind turbine with permanent magnet synchronous generator (PMSG) controlled with a full-scale power converter

Direct-in-line variable speed wind turbines have several drawbacks respect to the former variable speed DFIG concepts, which mainly include the power converter and output filter ratings at about 1 p.u. of the total system power. This feature reduces the efficiency of the

overall system and therefore results in a more expensive device. However, as the full scale power converter decouples entirely the wind turbine generator from the utility grid, grid codes such as fault ride through and grid support are easier to be accomplished, as required from modern applications. In addition, since a direct-in-line system can operate at low speeds, the gearbox can be omitted (direct-driven). Consequently, a gearless construction represents an efficient and robust solution that is beneficial, especially for offshore applications, where low maintenance requirements are essential. Moreover, using a permanent magnet synchronous generator, the DC excitation system is eliminated and allows reducing weight, losses, costs, and maintenance requirements (no slip rings are required). Even more, due to the intensified grid codes around the world, direct-driven PMSG wind turbine systems could be favoured in the future compared to DFIG wind turbine concepts (Li et al., 2009).

5. Technical exigencies for grid connection of wind generation

Any customer connected to a public utility electric network, whether generator or consumer, have to comply with agreed technical exigencies (aka demands or requirements) in order for the power grid to operate securely and efficiently. Electric power systems rely on generators to provide many of the control functions, and so the technical exigencies for generators are inevitably more complex than for demand customers. These technical requirements are often called “grid codes”, although the term should be used with care, as there are often different codes, depending on the voltage level of connection or the size of the application. In addition, there may be technical requirements that are not referred to the grid code, but which apply to the project through the connection agreement or the power purchase agreement or in some other way. Grid codes or interconnection guidelines can be summarized as a technical document containing the rules governing the operation, maintenance and development of the transmission system.

Large-scale penetration of wind generation may present a significant power contribution to the electric grid, and thus play an important role in power system operation and control (Slootweg & Kling, 2003). Consequently, high technical demands are expected to be met by these generation units. The purpose of these technical requirements is to define the technical characteristics and obligations of wind generators and the system operator (Martínez de Alegría et al. 2007), meaning that:

- Electric system operators can be confident that their system will be secure regardless of the wind generation projects and technologies applied.
- The amount of project-specific technical negotiation and design is minimised.
- Equipment manufacturers can design their equipment in the knowledge that the requirements are clearly defined and will not change without warning or consultation.
- Project developers have a wider range of equipment suppliers to choose from.
- Equivalent projects are treated fairly.
- Different wind generator technologies are treated equally.

This section includes the technical exigencies encountered in the majority of grid codes concerning wind generation interconnection. These include fault ride-through capability, system voltage and frequency operating range, reactive power and voltage regulation, active power regulation and frequency control as well as voltage flicker emission and harmonics emission.

5.1 Fault Ride-Through (FRT) capability

An important issue when integrating large-scale wind generation is the impact on the system stability and the transient behaviour. System stability is mainly associated with power system faults in the network such as tripping of transmission lines, loss of generation (generating unit failure) and short circuit. These failures disrupt the balance of power (active and reactive) and change the power flow. Although the capacity of the operating generators can be suitable, large voltage drops can occur suddenly and can propagate over very wide areas, affecting a great number of wind generators. The unbalance and re-distribution of active and reactive power in the network can force the voltage to vary beyond the boundary of stability. A period of low voltage (brownout) can occur and possibly be followed by a complete loss of power (blackout). (Jauch et al., 2004; Chen & Blaabjerg, 2009; Tsili & Papathanassiou, 2009).

Many faults in the power system are cleared by relay protections either by disconnection or by disconnection plus fast reclosing. In all the situations the result is a short period of low or no voltage followed by a period of voltage recovering. Some decades ago, when just a few wind turbines were connected to the grid, if a fault somewhere in the grid caused a short voltage drop at the wind turbine (aka voltage sag or dip), the wind turbine was simply disconnected from the electrical grid and had to be reconnected again when the fault was cleared and the voltage returned to the normal values. Because the penetration of wind generation in those days was low, the sudden disconnection of a wind turbine or even a wind farm from the grid did not cause a significant impact on the stability of the power system. With the increasing penetration of wind generation, the contribution of power generated by wind turbines is becoming a significant issue. If a large wind farm (or park) is abruptly disconnected when operates at full-rate, the power system will lose further production capability. Unless the remaining operating power plants have enough spinning reserve, in order to replace the lost power within very short time, a large power disturbance can occur and possibly be followed by a complete loss of power. It is, therefore, an essential requirement that wind generation is able to remain connected to the system during a power system fault, where the voltage on all three phases could fall to prevent extra generation losses. If wind generators are not able to ride-through voltage dips, the system will need a larger spinning reserve with consequent higher operating costs in order to avoid the system collapse because of the increasingly frequency drop.

The large increase in the installed wind capacity in transmission systems, especially in the last decade, requires that wind generation remains in operation in the case of disturbances and faults in the power system. For this reason, grid codes issued during the last years invariably demand that wind generation (especially those connected to high voltage grids) withstand voltage dips to a certain percentage of the nominal voltage (down to 0-15%) and for a specified duration (according to the country regulations). Such requirements are known as Fault Ride-Through (FRT) or Low Voltage Ride-Through (LVRT) capabilities and are described by a voltage vs. time characteristic such as the one shown in Fig. 4, denoting the minimum required immunity of the wind power generator (Kim & Dah-Chuan Lu, 2010). The FRT requirements under voltage dip is one of the main focuses of the grid codes and also include fast active and reactive power restoration to the pre-fault values, after the system voltage returns to its normal operation levels. Some codes impose increased reactive power generation by the wind turbines during the disturbance, in order to provide voltage support, a requirement that resembles the behaviour of conventional synchronous

generators in over-excited operation. The requirements depend on the specific characteristics of each power system and the protection employed and they deviate significantly from each other.

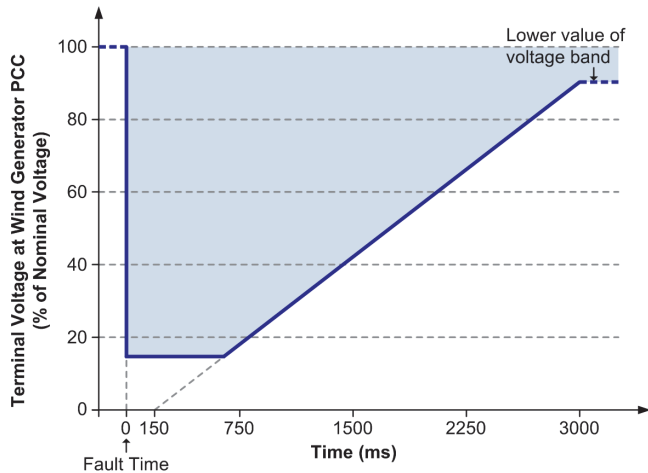

Fig. 4. Typical fault ride-through capability of a wind power generator

As previously described, the latest grid codes require that wind farms must remain in operation during severe grid disturbances, ensure fast restoration of active power to the pre-fault levels, as soon as the fault is cleared, and in certain cases produce reactive current in order to support grid voltage during disturbances. Depending on their type and technology, wind turbines can fulfil these requirements to different degrees.

In the case of fixed (constant) speed wind turbines, their low voltage behaviour is dominated by the presence of the direct grid-connected induction generator. In the event of a voltage dip, the generator torque reduces considerably (roughly by the square of its terminal voltage) resulting in the acceleration of the rotor, which may result in rotor instability, unless the voltage is restored fast or the accelerating mechanical torque is rapidly reduced. Further, operation of the machine at increased slip values results in increased reactive power absorption, particularly after fault clearance and partial restoration of the system voltage. This effectively prevents fast voltage recovery and can affect other neighbouring generators, whose terminal voltage remains depressed. Since the dynamic behaviour of the induction generator itself cannot be improved, a measure that can be employed in order to enhance the FRT capabilities of constant speed wind turbines is to supply reactive power through switched capacitors or static compensation devices connected at the wind turbine or wind farm terminals.

On the other hand, variable speed wind turbines, present the distinct advantages of direct generator torque and reactive current control and the possibility to endure large rotor speed variations without stability implications. For this reason, grid disturbances affect much less their operation and, generally, they are capable of meeting strict technical requirements.

In case of voltage disturbances, rotor overspeed becomes an issue of much smaller significance, since a limited increase of speed is possible (e.g. 10-15% above rated), the rotor inertia acting as an energy buffer for the surplus accelerating power, until the pitch

regulation becomes effective. In case of severe voltage dips, an energy surplus may occur in the electrical part, potentially leading to DC overvoltages. This is dealt with via proper redesign of the converter controllers, increase of the local energy storage capacity (e.g. capacitor size) or even by providing local power dissipation means. However, even with variable speed wind turbines there still exist LVRT issues affecting their response. In the case of DFIG wind turbines, the direct connection of the generator stator to the grid inevitably results in severe transients in case of large grid disturbances. Hence, the stator contributes a high initial short circuit current, while large currents and voltages are also induced in the rotor windings, as a consequence of the fundamental flux linkage dynamics of the generator. Furthermore, the depressed terminal voltage reduces accordingly the power output of the grid side rotor converter, leading to an increase of the DC bus capacitor voltage. To protect the power converters from overvoltages and overcurrents, DFIGs are always equipped with a device known as a crowbar that short-circuits the rotor terminals as soon as such situations are detected. Once the crowbar is activated, the DFIG behaves like a conventional induction machine, i.e. control is lost over the generator. Notably, crowbar activation is possible not only at the instant of a voltage depression, but also in case of abrupt voltage recovery, after clearance of a fault. Hence, although voltage dips inevitably cause torque and power transients in the DFIG wind turbine, which excite the rotor crowbar protection for a limited time interval, the various implementations of the active crowbar can improve the stability of the wind turbine and its response to sudden voltage changes.

Variable speed wind turbines with full-scale power converter present the distinct advantage that the converter totally decouples the generator from the grid. Hence, grid disturbances have no direct effect on the generator, whose current and torque variations during voltage dips are much lower compared to the DFIG and the respective transients fade out faster. From the point of view of the reactive output power, the grid side converter has the ability to produce reactive current during the voltage dip, up to its rated current. Notably, this wind turbine type can exhibit better voltage control capabilities even than conventional synchronous generators. Another notable advantage of this type against the DFIG-based wind turbines is related with the behaviour of the latter in case of unbalanced disturbances. In such situations, the low negative sequence impedance of the induction generator may give rise to large rotor currents, whose frequency lies outside the controllers bandwidth, resulting in the activation of the crowbar (or the disconnection of the stator) until the disturbance is cleared. Wind turbines can control their active power output by pitch control, while variable speed wind turbines have the additional capability for such control via variation of their rotor speed. Hence, power restriction, ramp rate limitations and contribution to frequency regulation is possible, even for constant speed machines. However, in the latter case the grid frequency is directly related to the generator slip and hence a change in frequency will transiently affect the active power produced by the wind turbine. In contrast, in the case of variable speed machines the generator power is directly controlled and therefore their primary frequency response is entirely adjustable via proper design of the control systems.

5.2 Voltage and frequency operating range

Wind farms must be capable of operating continuously within the voltage and frequency variation limits encountered in normal operation of the system. In addition, they should remain in operation in case of voltage and frequency excursions outside the normal operation limits, for a limited time and in some cases at reduced output power capability.

Tolerance to voltage variations in power systems depends on the level at the point of common coupling (PCC) of the wind power generator connected to the network. Transmission level voltages are usually considered to be 115 kV and above. Lower voltages such as 66 kV and 33 kV are usually considered sub-transmission voltages. Voltages less than 33 kV are usually used for distribution. Voltages above 230 kV are considered extra high voltage and require different designs compared to equipment used at lower voltages. The operating voltages at each voltage level are highly dependent on the local conditions and can be different in various countries. The lowest values are reached during operational disturbances and are usually not lower than 90% of the nominal voltage in the transmission level and can be down in some countries to 70% of the initial voltage for duration of up to 10 seconds, which must not lead to instability of the wind farm. Voltages above the upper limit for full-load voltage range is rarer and occurs for instance by reestablishment of the supply after major operational disturbances. These highest values are typically not higher than 113% in the transmission level. The system voltage operating range is generally narrower for higher voltage levels.

The frequency is one of the most important parameters in all power networks. The frequency of the electrical system varies by country; most electric power is generated at either 50 or 60 Hz. All the generating equipments in the electric system are designed to operate within very strict frequency margins. Grid codes specify that all generating plants should be able to operate continuously between a frequency range around the nominal frequency of the grid, usually between 49.5 and 50.5 Hz (for 50 Hz systems such as in Europe), and to operate for different periods of time when lower/higher frequencies down/up to a minimum/maximum limit, typically 47.5 and 52 Hz. Operation outside these limits would damage the generating plants, so even very short duration deviations from the nominal frequency values would trip load shedding relays and generation capacity would be lost. The lost of generation leads to further frequency deviation and a blackout can occur. Wind farms have to be dimensioned to generate power at voltages and frequencies deviated from rated values in the way indicated in Fig. 5, showing the power restriction in different operating areas (Eltra & Ekraft System, 2004). In this diagram, V_L is the lower voltage limit while V_{LF} is the lower voltage limit for full-load range for a nominal voltage V_N . In the same way, V_H is the upper voltage limit while V_{HF} is the upper voltage limit for full-load range. These voltage limits in a 132 kV (V_N) transmission grid may have values such as 119 kV for V_L , 125 kV for V_{LF} , 145 kV for V_H and 155 kV for V_{HF} for the case of the Danish system. The full-load range indicates the voltage range within which the wind farm can supply its nominal power without any restriction (continuous operation area).

5.3 Reactive power control and voltage regulation

Reactive power control is very significant for wind farms, because not all wind generation technologies have the same capabilities, while wind farms are often installed in remote areas and therefore reactive power has to be transported over long distances resulting in power losses. Some wind farms are required to have sufficient reactive power compensation to be neutral in reactive power at any operating point. Recent grid codes demand from wind farms to provide reactive output regulation, often in response to power system voltage variations, much as the conventional power plants.

The reactive power control requirements are related to the characteristics of each network and the voltage level considered, since the influence of the reactive power injection on the

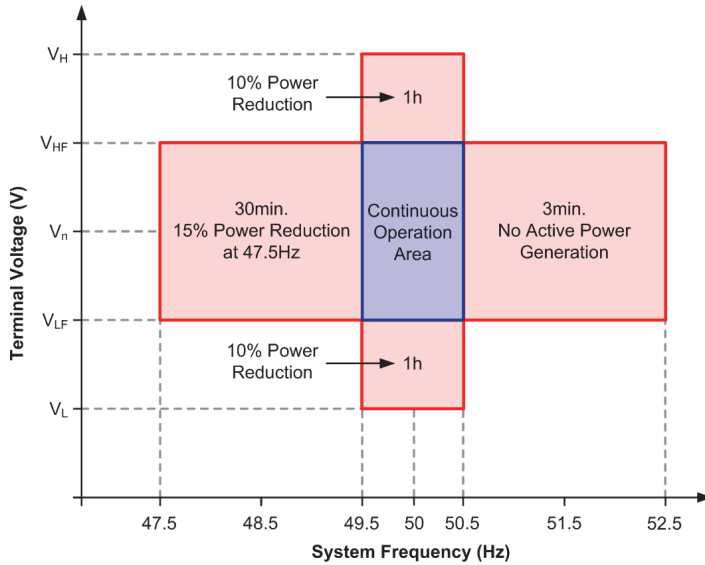

Fig. 5. Typical voltage and frequency dimensioning for wind generators

voltage profile is directly determined by the short-circuit capacity and impedance at the PCC of the wind farm. The short-circuit capacity at a given point in the electrical network represents the system strength or robustness. It is clear that the variations of the generated power result in variations of the voltage at PCC. If the impedance is small (the grid is strong) then the voltage variations are small. On the other hand, if the impedance is large (the grid is weak), then the voltage variations are large.

Voltage is closely related to the reactive power; consequently wind turbines with the ability of controlling reactive power can support and regulate the PCC local system voltage. Modern large wind farms are required to have the ability of controlling both active and reactive power. In the case of the fixed speed wind turbines with conventional induction generators, the reactive power can be controlled by thyristor-switched capacitor banks. Furthermore, a dynamic reactive power control unit based on power converters can additionally be installed at the PCC although at higher costs. In the case of power electronic converter-based variable speed wind turbines, such as those with DFIG systems or with full-scale power converters, the reactive power control can be performed by the converter itself. Consequently, significant active power fluctuations from the wind speed variations may not lead to corresponding fluctuations of the grid voltage at the connection point of the wind farm. Some codes recommend that the transmission system operators (TSOs) may define a set-point value for voltage or power factor or reactive power at the PCC of the wind farm.

A Voltage Regulator (VR) is included in modern wind generator in order to determine its terminal voltage magnitude to supply (or absorb) to the transmission system the desired amount of reactive power. A mismatch between the supply and demand of reactive power results in a change in the system voltage: if the supply of lagging reactive power is less than the demand, a decrease in the system voltage results; conversely, if the supply of lagging reactive power exceeds the demand, an increase in system voltage results. There are rigorous requirements on the extent to which the system voltage can be allowed to deviate

from its nominal values ($\pm 10\%$ for low voltage networks and $\pm 5\%$ for medium or high voltage networks). Voltage or reactive power requirements in the grid codes are usually specified with a limiting curve such as that shown in Fig. 6 (Martínez de Alegría et al. 2007). The mean value of the reactive power over several seconds should stay within the limits of the curve. When the generating unit is providing low active power the power factor may deviate from unity because it can support additional leading or lagging currents due to the reactive power demanded by the utility. When the generating unit is working under nominal conditions, the power factor must be kept close to unity so that it avoids excessive currents. Another advantage of local reactive power generation is the reduction of losses in the system. As the reactive power is locally generated and locally consumed, the current through all upstream devices and the power losses in the network are reduced. Thus, the wind farm should have the capability to control the voltage and/or the reactive power at the PCC. This is essential in order to ensure secure operation of the system. The wind farm operator has the opportunity to gain additional payments for providing reactive power.

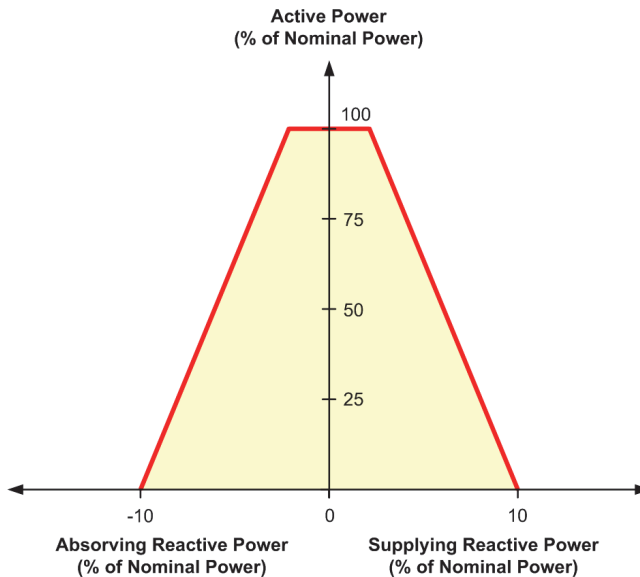

Fig. 6. Typical reactive power limiting curve for wind generators

5.4 Active power control and frequency control

One of the most important and limiting factors in wind power integration into the electric grid is the spinning reserve needed due to the unpredictability of wind and the possible sudden loss of wind generation. Usually, a good prediction of the wind can be achieved 1–4 h in advance; although better prediction methods are still needed. In order to avoid a collapse in the power system, adequate spinning reserve or very strong connections with neighbour countries are necessary.

Active power control requirements for supporting and stabilizing the system frequency refer to the ability of wind farms to regulate (usually, but not exclusively, reducing) their power output to a defined level (active power restriction), either by disconnecting turbines

or by pitch control action for the case of variable speed wind turbines. In addition, wind farms are required to provide frequency response, that is, to regulate their active output power according to the frequency deviations (Lalor et al., 2005). In some countries, generation based on intermittent sources of energy (i.e. wind and solar power) are exempted from the obligation to supply primary reserves. Neither do they, neither have to offer any capacity as reserve power or regulating power to the TSO. In some other countries, such as Germany, Ireland and Denmark, their grid codes demand that wind farms have the ability of active power restriction. Some other like the British code requires that wind farms have a frequency control device capable of supplying primary and secondary frequency control, as well as over-frequency control. As a general remark, it is clear that most grid codes require wind farms (especially those of high capacity) to provide frequency response, i.e. to contribute to the regulation of system frequency. It should be emphasized that the active power ramp rates must comply with the respective rates applicable to conventional power units.

Fig. 7 shows a typical grid code-limiting curve for frequency controlled regulation of the active power (Martínez de Alegría et al. 2007). High-frequency response can be provided from full output to a reduced output when the frequency exceeds 50 Hz and the new grid codes require that when the frequency increases above the rated value generating plants should decrease their output at a given rate. On the other hand, at nominal frequency, the wind farms would be required to limit their power output below the maximum achievable power level. By doing so, if the frequency starts to drop, the wind farm would increase the power output to the maximum achievable power, trying to sustain the frequency.

The provision of frequency response will be purchased based on the prices placed in the market. High-frequency response from wind powered generation is a service already of interest, especially at minimum demand conditions and it could become an additional source of income for wind farm owners. Low-frequency response capability would be interesting if the pay for such response would compensate the loss of generated power.

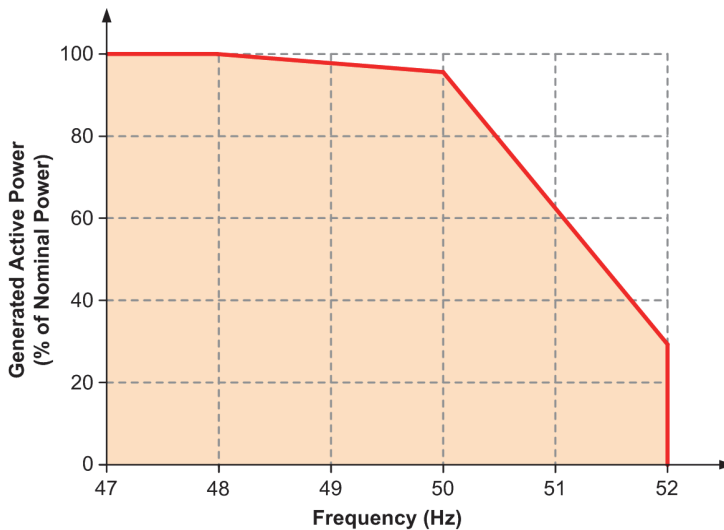

Fig. 7. Typical frequency controlled regulation of active power

5.5 Voltage flicker emission

Flicker is another voltage quality issue on wind power generation associated with the electric grid. Flicker is defined as a measure of annoyance of flickering light bulbs on human, caused by active and reactive power fluctuation as a result of the rapid change in wind speed. Fluctuations in the system voltage (more specifically in its RMS value) can cause perceptible light flicker depending on the magnitude and frequency of the fluctuation. This type of disturbance is called voltage flicker, or shortened as flicker (Bollen, 2000).

There are two types of flicker emissions associated with wind turbines, i.e. during continuous operation and switching operation due to the generator and capacitor switchings. The switching operation is the condition of cut-in and cut-out by the wind turbine. The standard IEC 61400-21 (2008) requires flicker to be monitored in these two operation modes. Frequently, one or the other is the predominant. The acceptable flicker limits are generally established by individual utilities. Rapid variations in the power output from a wind turbine, such as generator switching and capacitor switching, can also result in variations in the RMS value of the voltage. At certain rate and magnitude, the variations cause flickering of the electric light. In order to prevent flicker emission from impairing the voltage quality, the operation of the generation units should not cause excessive voltage flickers. It is reported that flicker is relatively less critical issue in variable speed wind turbine generation systems; however, it needs to be improved for higher power quality.

The flicker emissions from a wind turbine installation should be limited to comply with the flicker emission limits. It is recommended that the long term flicker severity factor P_{1t} , calculated with a "flicker algorithm" defined for 2 h periods, lesser or equal than 0.50 in 10–20 kV networks and $P_{1t} \leq 0.35$ in 50–60 kV networks are considered acceptable. However, different utilities may have different flicker emission limits.

5.6 Harmonics emission

Harmonic disturbances are a phenomenon associated with the distortion of the fundamental sine wave and are produced by nonlinearity of electrical equipment. Harmonic emission is another crucial issue for grid connected wind turbines because it can result in voltage distortion and torque pulsations, which consequently causes possible destructive overheating in the generator and in other equipment, and other problems such as increased currents and additional power losses (Bollen, 2000). Harmonics can also raise problems in communication and control systems. Although wind turbines emit low-order harmonics by nature, self-commutated power electronic converters used in modern variable speed wind turbines can filter out this low-order harmonics. In addition, the pulse width modulation (PWM) switching strategy employed to control these converters, with a typical switching frequency of a few thousand Hz, shifts the harmonics to higher frequencies where the harmonics can be easily removed by smaller filters (Acha et al., 2002). However, the self-commutated converters introduce high-order harmonics instead. In addition, inter-harmonics, which is non-integer harmonics, is another type of harmonic emission by these technologies. It contributes to the level of the flicker and has an interference with control and protection signals in power lines, which are regarded as the most harmful effects on the power system.

Harmonic standards are specified to set up the limits on the Total Harmonic Distortion (THD) as well as on the individual harmonics. Wind turbine power quality standard IEC 61400-21 (2008), along with harmonic measurement standard IEC 61000-4-7 (2008), provides

the requirements for on current harmonics, current inter-harmonics and higher current components to be measured and reported in modern wind power systems.

6. Regulatory exigencies for grid connection of wind generation in selected countries

This section briefly describes major technical regulations for grid connection of wind generation in selected countries such as Germany, Denmark and Argentina (Alboyaci & Dursun, 2008).

6.1 Germany

The German interconnected transmission system operates at voltage levels 220 kV and 380 kV (Lines of less than 150 kV are considered distribution lines in Germany) and is divided into four control areas, each in responsibility of one TSO: RWE Transportnetz Strom GmbH, E.ON Netz GmbH, Vattenfall Europe Transmission (VE-T) GmbH and EnBW Transportnetze AG. Together, the four control areas form the German control block, which makes part of the UCTE (Union for the Co-ordination of Transmission of Electricity) synchronous zone in continental Europe (Erlich & Bachmann, 2005). These TSOs issued grid requirements on wind turbine connection and operation on the electric grid (E.ON Netz, 2006). Simultaneously, the association of German transmission grid operators, VDN, summarized special requirements concerning renewable energy sources operating on the high voltage network in a document as an appendix to the existing general grid codes (Alboyaci & Dursun, 2008).

According to the German code, the requirements of transient fault behaviour of wind generators are divided mainly in two categories: one for generators with large contribution to the fault current at the grid connection requirement (GCR) i.e. the fault current is at least two times the nominal current for at least 150 ms, and one for generators where the fault current contribution is less than that.

Onshore wind farms require connection to the 380 kV high voltage system and must be treated like conventional power plants. However, new technical solutions are required for connecting large wind farms at a distance of 100-200 km offshore to the mainland. The German code related to the FRT (or LVRT) requirements of wind farms stipulate that they must remain connected during voltage dips down to 0%. However, it must be noted that these requirements apply to the PCC to the network, generally at high voltage level. This indicates that the corresponding voltage dip at lower voltage levels, i.e. near the wind turbine terminals, are likely to be rather above 15%.

The frequency range that wind turbines have to tolerate is about 47.5–51.5 Hz. It must be possible to limit the active power output from every operating point as a percentage of the nominal power. For power reduction a ramp rate of at least 10% of nominal power per minute must be possible.

It has to be possible to operate wind farms with nominal power of less than 100 MW with power factor between 0.95 lagging and 0.95 leading. The required power factor values are always applied at the grid connection point. Wind farms rated 100 MW or more have to be able to operate at power factor between 0.925 lagging and 0.95 leading. The power factor range is however limited depending on the grid voltage to avoid leading power factor at grid voltages below nominal values. Generators with small fault current contribution are

required to support grid voltage in case of faults by supplying reactive power proportional to the voltage drop. Between 10% and 50% voltage drop the generators have to supply reactive current between 10% and 100% rated current, linearly proportional to the voltage. Generators with big fault current contribution, on the other hand, are not required to contribute to voltage support during transient faults.

6.2 Denmark

The Danish transmission system operates at voltage levels 132 kV, 150 kV and 400 kV and has historically been administered by two independent TSOs: Eltra in the West, and Elkraft System in the East. In 2005, these merged to form the new state-owned operator, Energinet Denmark which also oversees operation of the gas network. The two separate TSOs arose because their respective networks were geographically and electrically separate from each other (Eltra & Ekraft System, 2004).

While not directly connected, both are interconnected to neighbouring countries. Western Denmark is synchronized by the UCTE system with Germany and has 1670 MW of DC links with Norway and Sweden. Eastern Denmark is part of the NordPool market and is connected synchronously to Sweden and asynchronously to Germany. While the physical transfer capability is significant, there are operational limits of 800 MW to the North and 1300 MW to the South because of congestion on their neighbours' grid (Eltra & Ekraft System, 2004; Alboyaci & Dursun, 2008).

According to the Danish code, no specific voltage operating ranges and respective trip times in transient fault situations are specified in these grid connection requirements. Wind farms have to stay connected and stable under permanent 3-phase faults on any arbitrary line or transformer and under transient 2-phase fault (unsuccessful auto-reclosure) on any arbitrary line. In the case of a fault incidence, the voltage can be down to 70% of the initial voltage for duration of up to 10 seconds, which must not lead to instability of the wind farm. The controllability of the wind farm must be sustained for up to 3 faults within 2 minutes, or for up to 6 faults if the delay between the faults is 5 minutes; each fault happening during steady state operation. This requirement makes sure that the turbines are fitted with sufficient auxiliary power supplies. When the voltage falls after a fault below 60–80% for longer than 2–10 seconds, it is likely that the turbines have accelerated so much, that the grid cannot get them back to normal speed. The Danish code related to the FRT requirements of wind farms stipulate about the same requirements than the German counterpart, i.e. wind generators must remain connected during voltage dips down to 0% at the PCC to the high voltage network (above 15% at the lower voltage wind turbine terminals). However, these specifications may vary according to the voltage level or the wind farm power: e.g. wind farms connected to the Danish grid at voltages below 100 kV are required to withstand less severe voltage dips than the ones connected at higher voltages, in terms of voltage dip magnitude and duration.

The frequency range that wind turbines have to tolerate is about 47–53 Hz. Controlled limitation of active power is demanded to limit the reactive power demand of wind farms after a fault. In addition, power limitation is demanded to ensure supply and demand balance if a part of Denmark becomes an island due to a fault. It must be possible to reduce power to less than 20% of nominal power within less than 2 seconds. This corresponds to a ramp rate of 40% of rated power per second.

Wind farms are required to have sufficient reactive power compensation to be neutral in reactive power at any operating point. This requirement has to be fulfilled at the grid connection point. In the 150 kV system, steady state operation has to be possible under full load in the voltage range between 0.95 p.u. and 1.13 p.u. In the 400 kV system the voltage range is narrower, hence less onerous for generators to cope with. If the voltage reaches 1.2 p.u. at the grid connection point (irrespective of the voltage level) the wind farm has to start performing voltage reduction within 100ms of detection. Voltage reduction can be achieved by switching reactors to increase the reactive power demand of the wind farm.

6.3 Argentina

Argentina has one of the best regions of wind characteristics of the world, which is The Patagonia. For many experts, the Patagonian wind is the world's best quality continental resource. The meteorological average wind speed in this region is from 5 to 10 m/s approximately at 10 m height. The meteorological wind power at 10 m height of Patagonia is about 200 GW. However, the wind energy market in Argentina has not yet taken off because of lack of effective government policy stimulus.

The Argentinean interconnected transmission system operates at voltage levels 132 kV, 220 kV and 500 kV and is in responsibility of just one TSO: CAMMESA (Wholesale Electricity Market Administration Company). This TSO has issued preliminary grid requirements concerning wind turbine connection and operation on the high voltage network in a document as an appendix No. 40 (CAMMESA, 2010) to the existing general grid codes (aka the procedures).

According to the Argentinean code, the requirements of transient fault behaviour of wind generators are separated in two groups: wind farms type A with big contribution to the fault current at the grid connection requirement and wind farms type B with the fault current contribution lesser than the previous category.

Wind farms must be treated as conventional run-of-river hydraulic power plants. However, those issues of exclusive nature to wind generation are defined in the appendix No. 40. This last document briefly considers four aspects: (a) requirements of insertion to the grid, (b) voltage control and reactive dispatch, (c) operation and restrictions and (d) power quality.

The main condition for a wind farm to be accepted to be included into the wholesale electricity market is its size, which must be larger than 1 MW.

The wind farm must perform the obligations of supply and absorption of reactive power so that exhibits a power factor ($\cos \varphi$) of 0.95 either inductive or capacitive at the PCC to the network. For the case of wind farms type A, the maximum admissible voltage disturbance at the PCC to the grid as a consequence of the larger rapid variation of generation and the greater variation of frequent generation is 1% for network voltage levels between 132 kV and 500 kV, 2% for levels between 35 kV and 132 kV and 3% for voltage levels lower than 35 kV. In this case, the wind farm must operate controlling the voltage at the PCC or at an internal bus, and must include a cooperative control so as to share the reactive power among each wind generator. For the case of wind farms type B, since the larger rapid variation of generation and the greater variation of frequent generation produce voltage changes lesser than the previously indicated, then it is not required that the wind farm operates controlling the terminal voltage level and may operate at the fixed power factor required by the TSO. The Argentinean code related to the FRT requirements of wind farms stipulate that they must remain connected during voltage dips down to 0 at the PCC to the

high voltage network (above 15% at the lower voltage wind turbine terminals). The frequency range that wind turbines have to tolerate is about 47.5–52.5 Hz. Wind turbines must meet, in regard to injection of harmonics, flicker, etc. with standard IEC 61400–21.

7. Conclusion

This chapter has provided an overall perspective of modern wind power systems, including a discussion of major wind turbine concepts and technologies. More specifically, of the various wind turbine designs, pitch-controlled variable speed wind turbines controlled by means of power electronic converters have been considered. A revision of modern structures of wind turbines has also been carried out, including towers and foundations, rotor, nacelle with drive train and other equipment, and control system, among others. In the survey, the technical exigencies encountered in the majority of grid codes concerning wind generation interconnection have been deeply reviewed. These include fault ride-through capability, system voltage and frequency operating range, reactive power and voltage regulation, active power regulation and frequency control as well as voltage flicker emission and harmonics emission. Moreover, an analysis of the different grid codes emitted by the organizations entrusted to regulate the electrical sector in selected countries such as Germany and Denmark has been carried out and compared to Argentina.

8. Acknowledgments

The authors wish to thank the CONICET (Argentinean National Council for Science and Technology Research), the IEE (Institute of Electrical Energy), the Department of Electromechanical Engineering, and the Faculty of Engineering of the Universidad Nacional de San Juan, for the financial support of this work.

9. References

- Acha, E.; Agelidis, V.; Anaya-Lara, O. & Miller, T. (2002). *Power Electronic Control in Electrical Systems*, Newness, 1st ed., United Kingdom.
- Ackermann, T. (2005). *Wind Power in Power Systems*, John Wiley & Sons, 1st Ed., United Kingdom.
- Alboyaci, B. & Dursun, B. (2008). Grid Connection Requirements for Wind Turbine Systems in selected Countries – Comparison to Turkey. *Electrical Power Quality & Utilization Magazine*. Vol. 3, No. 2, pp. 1-15.
- Blaabjerg, F.; Chen, Z & Kjaer, S. B. (2004). Power Electronics as Efficient Interface in Dispersed Power Generation Systems. *IEEE Trans. on Power Electronics*, Vol. 19, No. 5, pp. 1184-1194.
- Blaabjerg, F. & Chen, Z. (2006). *Power Electronics for Modern Wind Turbines*, Morgan & Claypool Publishers, 1st Ed., Seattle, WA, USA.
- Bollen, M. H. J. (2000). *Understanding Power Quality Problems*. IEEE Press, Piscataway, New Jersey, USA.
- CAMMESA (2010). *Los Procedimientos – Anexo 40: Generación Eólica (The Procedures – Appendix No. 40: Wind Generation)*. Technical Report (in Spanish).
- Carrasco, J. M.; Garcia-Franquelo, L.; Bialasiewicz, J. T.; Galván, E; Portillo-Guisado, R. C.; Martín-Prats, M. A.; León, J. I. & Moreno-Alfonso, N. (2006). Power Electronic

- Systems for the Grid Integration of Renewable Energy Sources: A Survey. *IEEE Trans. on Industrial Electronics*, Vol. 53, No. 4, pp. 1002-1016.
- Chen, Z. & Blaabjerg, F. (2009). Wind Farm – A Power Source in Future Power Systems. *Renewable and Sustainable Energy Reviews*, Vol. 13, No. 6-7, pp. 1288-1300.
- Eltra & Ekraft System (2004). *Regulation TF 3.2.5: Wind Turbines Connected to Grids with Voltages Above 100 kV. Technical Regulation for the Properties and the Regulation of Wind Turbines*. Technical Report.
- E.ON Netz (2006). *Grid Code High and Extra High Voltage*. Technical Report.
- Erlich, I.; Bachmann, U. (2005). Grid Code Requirements Concerning Connection and Operation of Wind Turbines in Germany, *Proceeding of the IEEE Power Engineering Society General Meeting*, Vol. 2, pp. 1253-1257.
- Freris, L. L. (1990). *Wind Energy Conversion Systems*, Prentice-Hall, 1st Ed., New Jersey, USA.
- Guerrero, J. M.; Blaabjerg, F.; Zhelev, T.; Hemmes, K.; Monmasson, E.; Jemei, S.; Comech, M. P.; Granadino, R. & Frau, J. I. (2010). Distributed Generation: Toward a New Energy Paradigm. *IEEE Industrial Electronics Magazine*, Vol. 4, No. 1, pp. 52-64.
- Hansen, A. D.; Iov, F.; Blaabjerg, F. & Hansen L. H. (2004). Review of contemporary wind turbine concepts and their market penetration, *Journal of Wind Engineering*, Vol. 28, No. 3, pp. 247-263.
- Heier, S. (2006). *Grid Integration of Wind Energy Conversion Systems*, John Wiley & Sons, 1st ed., United Kingdom.
- IEC 61000-4-7 (2008). *Electromagnetic Compatibility (EMC) – Part 4-7: Testing and Measurement Techniques – General Guide on Harmonics and Interharmonics Measurements and Instrumentation, for Power Supply Systems and Equipment Connected Thereto*.
- IEC 61400-21 (2008). *Wind Turbines – Part 21: Measurement and Assessment of Power Quality Characteristics of Grid Connected Wind Turbines*.
- Jauch, C.; Sorensen, P. & Jensen, B.B. (2004), International Review of Grid Connection Requirements for Wind Turbines. *Proceedings of Nordic Wind Power Conference, (NWPC 04)*, Göteborg, Sweden.
- Kim, H. S. & Dah-Chuan Lu, D. (2010). Wind Energy Conversion System from Electrical Perspective – A Survey. *Smart Grid and Renewable Energy*, Vol. 1, pp. 119-131.
- Labriola, C. V. M. (2007). Wind Potential in Argentina, Situation and Prospects. *Proceedings of the International Conference on Renewable Energies and Power Quality (ICREPQ)*, Sevilla, España.
- Lalor, G.; Mullane, A. & O'Malley, M. (2005). Frequency control and Wind Turbine Technologies, *IEEE Trans. on Power Systems*, Vol. 20, No. 4, pp. 1905-1913.
- Li, S.; Haskew, T. A.; Muljadi, E. & Serrentino, C. (2009). Characteristic Study of Vector-Controlled Direct-Driven Permanent Magnet Synchronous Generator In Wind Power Generation. *Electric Power Components and Systems*, Vol. 37, No. 10, pp. 1162-1179.
- Martínez de Alegría, I.; Andueza, J.; Martínez, J. L.; Ibañez, P., Villate, J. L. & Camblong, H. (2007). Connection Requirements for Wind Farms: A Survey on Technical Requirements and Regulation, *Renewable and Sustainable Energy Reviews*, Vol. 11, No. 8, pp. 1858-1872.
- Molina, M. G. & Mercado, P. E. (2011). *Modelling and Control Design of Pitch-Controlled Variable Speed Wind Turbines*. In: *Wind Turbines, Al-Bahadly, I. (Ed.)*, 1st ed., InTech, Vienna, Austria, pp. 1-30.

- Muller, S.; Deicke, M. & De Doncker, R. W. (2002). Doubly Fed Induction Generator Systems for Wind Turbines. *IEEE Industry Applications Magazine*, Vol. 8, No. 3, pp. 26-33.
- Qiao, W.; Harley, R. G. & Venayagamoorthy, G. K. (2007). Dynamic Modeling of Wind Farms With Fixed-Speed Wind Turbine Generators, *Proceedings of IEEE PES 2007 General Meeting*, June 24-8, Tampa, USA.
- Rahman, S. (2003). Going Green: The Growth of Renewable Energy, *IEEE Power and Energy Magazine*, Vol. 1, No. 6, pp. 16-18.
- Slootweg, J. G. & Kling, W. L. (2003). The Impact of Large Scale Wind Power Generation on Power System Oscillations, *Electric Power Systems Research*, Vol. 67, No. 1, pp. 9-20.
- Stiesdal, H. (1999). The Wind Turbine: Components and Operation, *Special Issue of the Bonus Energy A/S Info Newsletter*, Vol. 1, No. 1, pp. 1-25.
- Thomsen, H. J.; Forsberg, T. & Bittner, R. (2007). Offshore Wind Turbine Foundation: The COWI Experience. *Proceedings of the ASME 26th International Conference on Offshore Mechanics and Arctic Engineering (OMAE)*, San Diego, California, USA.
- Timbus, A.; Liserre, M.; Teodorescu, R.; Rodriguez, P. & Blaabjerg, F. (2009). Evaluation of Current Controllers For Distributed Power Generation Systems, *IEEE Transactions on Power Electronics*, Vol. 24, No. 3, pp. 654-664, March 2009.
- Tsili, M. & Papathanassiou, S. (2009). A Review of Grid Code Technical Requirements for Wind Farms. *IET Renewable Power Generation*, Vol. 3, No. 3, pp. 308-332.
- Vestergaard, J.; Brandstrup, L. & Goddard, R. D. (2004). A Brief History of the Wind Turbine Industries in Denmark and the United States. *Proceedings of the Academy of International Business (Southeast USA Chapter) Annual Meeting*, Knoxville, Tennessee, USA.
- Villalobos Jara, F. A. (2009). Foundations for Offshore Wind Turbines. *Revista Ingeniería de Construcción*, Vol. 24, No. 1, pp. 33-48.

O&M Cost Estimation & Feedback of Operational Data

Tom Obdam, Henk Braam, René van de Pieterman and Luc Rademakers
Energy research Centre of the Netherlands (ECN)
The Netherlands

1. Introduction

Several European countries have defined targets to install and to operate offshore wind energy and according to these targets more than 40 GW offshore wind power is expected for the year 2020. With an average turbine size of about 5 - 10 MW, four to eight thousand wind turbines should be transported, installed, operated and maintained. When not only the European plans are considered, but all international developments as well, these numbers are much higher. So worldwide the required effort for operation and maintenance (O&M) of offshore wind farms will be enormous, and control and optimisation of O&M during the lifetime of these offshore wind turbines is essential for an economical exploitation. At the moment O&M costs of offshore wind farms contribute substantially (2 to 4 ct/kWh) to the life cycle costs, so it may be profitable to check periodically whether the O&M costs can be reduced so that the total life cycle costs can be reduced (Rademakers, 2008b; Manwell)

During the *planning phase* of a wind farm an estimate of the expected O&M cost over the life time has to be made to support the financial decision making, and furthermore quite often an initial O&M strategy has to be set up. To support this process ECN has developed the O&M Tool (Rademakers 2009a). With this computer program developed in MS-Excel it is possible to calculate the average downtime and the average costs for O&M over the life time of the wind farm. Both preventive and corrective maintenance can be considered. To analyse corrective maintenance the failure behaviour of the wind turbine has to be modelled and a certain maintenance strategy has to be set up, i.e. for each failure or group of failures it has to be specified how many technicians are needed, how these technicians are transferred to the wind turbine (small boats, helicopter, etc.) and whether a crane ship is needed. By carrying out different scenario studies the most effective one can be considered for more detailed investigations and technical assessment. The long term yearly costs and downtime are calculated and for this purpose it is sufficient to assume a constant failure rate of the wind turbines over the life time, hence it is assumed that the number of failures of a certain type is constant over the years. With this assumption the annual cost and downtime for a certain failure equals the product of number of failures of this type per year, and the downtime or cost associated with this type of failure. The total cost is a simple summation over all failures assumed to occur. So the determination of the annual cost and downtime is a straightforward operation. Once the model has been set up, the effect of adjusting an input parameter is visible immediately, which makes the O&M Tool a powerful tool commonly used by the wind industry. However, the straightforward method based on long term

average values introduces some limitations as well. As the actual variation in failure rate from year to year is not considered, the tool is not really suitable to estimate the O&M effort for the coming period of e.g. 1, 2 or 5 years, which is required to control and optimise O&M of a wind farm in the operational phase. For this reason ECN initiated the idea of developing the “O&M Cost estimator” (OMCE), as a tool that could be used by operators of large offshore wind farms.

W.r.t. O&M during *operation* of a wind farm it is important (1) to monitor the actual O&M effort and (2) to control and to optimise future O&M costs. For both aspects operational data available for the wind farm are required. To be able to control the future costs and when possible to optimise the O&M strategy a computer tool is desired to estimate and to analyse the expected cost for the coming period. To support the process of monitoring, control, and optimisation ECN has started the development of the O&M Cost Estimator (Rademakers 2009a, 2009b; Pieterman). To handle both aspects, processing of operational data and prediction of future O&M costs two major parts can be distinguished:

1. OMCE Building Blocks for processing of operational data, where each building block covers a specific data set. Currently BB's are being developed for the following data sets:
 - *Operation and Maintenance;*
 - *Logistics;*
 - *Loads and Lifetime;*
 - *Health Monitoring;*

The main objective of these building blocks is to process all available data in such a way that useful information is obtained, which can be used on the one hand as input for the OMCE-Calculator and on the other hand to monitor certain aspects of the wind farm.

2. OMCE-Calculator for the assessment of the expected O&M effort and associated costs for the coming period, where amongst others all relevant information provided by the OMCE Building Blocks is taken into account.

In contrary to the ECN O&M Tool, the OMCE-Calculator is meant to be used during the operational phase of a wind farm, to estimate the required O&M effort for the coming period, taking into account the operational experiences of the wind farm acquired during the operation of the wind farm so far. This implies that for the OMCE model it is not sufficient to determine long term yearly average numbers, but that another approach has to be followed, viz. simulation in the time domain. Furthermore the feedback of operational experience is of great importance for the OMCE model. This approach enables the possibility to include features not straightforward possible in the O&M Tool, such as clustering of repairs at different wind turbines, spare control, optimisation of logistics of offshore equipment, and so on.

In the following sections firstly some more general information is provided on modelling the O&M aspects of offshore wind farms. Secondly, the OMCE project is discussed in more detail. In sections 3 and 4 some examples are provided to illustrate the possibilities of, respectively, the OMCE-Calculator and the OMCE-Building Blocks. Finally, in section 5 the main conclusions are summarised.

2. Modelling O&M of offshore wind farms

2.1 O&M aspects

A typical lay-out of an offshore wind farm is sketched in Figure 1. The wind farms consist of a number of turbines, switch gear and transformers (mostly located within the wind farm) and a

substation onshore to feed in the electrical power into the grid. The first wind farms are located in shallow waters at short distances from the shore in order to gain experiences with this new branch of industry. Presently, most offshore wind farms are located at distances typically 8 to 30 km from the shore in water depths of 8 to 30 m. Usually mono-piles are being used as a sub-structure and the turbine towers are mounted to the mono-piles by means of transition pieces. The size of an offshore wind farm is 50 to 200 MW and consists of turbines with a rated power of typically 1 to 3 MW. Future wind farms are planned further offshore and will consist of larger units, typically 5 MW and larger, and the total installed capacity will be 200 to 500 MW, but also wind farms with a capacity in the order of 1 GW are considered. New and innovative substructures are presently being developed to enable wind turbines to be sited in deeper waters and to lower the installation costs, see Figure 2.

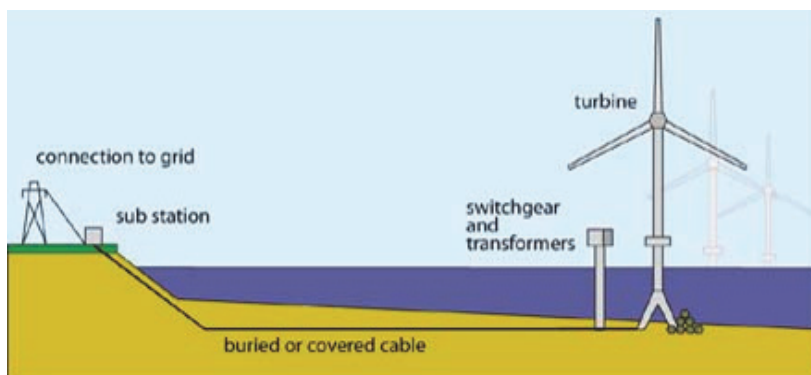

Fig. 1. Typical lay-out of an offshore wind farm (<http://www.offshore-sea.org.uk/site/>).

All systems and components within the wind farm need to be maintained. Typically for preventive maintenance, each turbine in a wind farm is being visited twice a year and each visit has a duration of 3 to 5 days. In addition a number of visits for corrective maintenance are needed due to random failures. Public information about corrective maintenance is very limited, but numbers of 5 visits or more are not unrealistic. In the future it is the aim to improve the turbine reliability and maintainability and reduce the frequency of preventive maintenance to no more than once a year. The number and duration of visits for corrective maintenance should be decreased also by improved reliability and improved maintainability. With the use of improved condition monitoring techniques the effects of random failures can be reduced by applying condition based maintenance. In addition to the turbine maintenance, also regular inspections and maintenance are carried out for the sub-structures, the scour protection, the cabling, and the transformer station. During the first year(s) of operation the inspection of substructures, scour protection, and cabling is done typically once a year for almost all turbines. As soon as sufficient confidence is obtained that these components do not degrade rapidly operators may decide to choose longer inspection intervals or to inspect only a sub-set of the total population.

The maintenance aspects relevant for offshore wind farms are among others:

- **Reliability of the turbines.** As opposed to onshore turbines, turbine manufacturers design their offshore turbines in such a way that the individual components are more reliable and are able to withstand the typical offshore conditions. This is being done by reducing the number of components, choosing components of better quality, applying

climate control, using automatic lubrication systems for gearboxes and bearings, etc. Often, the turbine control is modified in such a way that not all single failures lead to a stand still. Making better use of the diagnostics and using redundant sensors can assist in this.

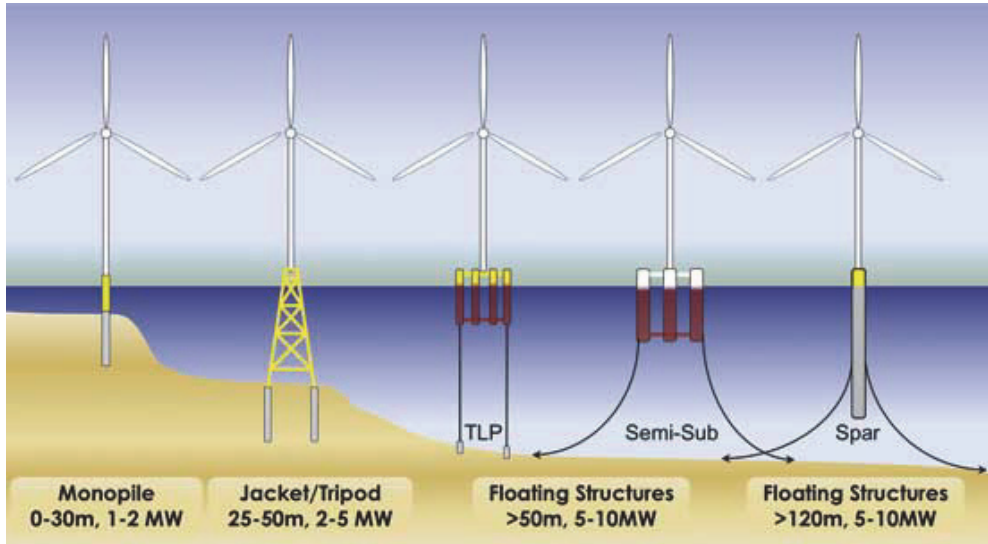

Fig. 2. Sub-structures (Roddier).

- Maintainability of the turbines.** If offshore turbines fail, maintenance technicians need to access the turbines and carry out maintenance. Especially in case of failures of large components, offshore turbines are being modified to make replacements of large components easy, e.g. by making modular designs, or by building in an internal crane to hoist large components, see for example Figure 3.

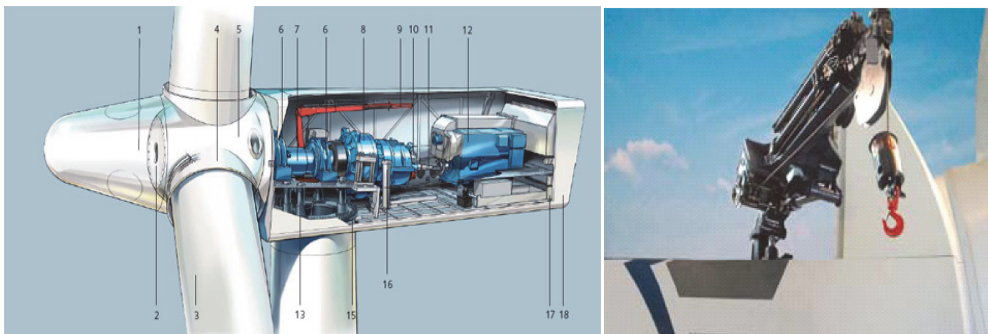

Fig. 3. Examples of internal cranes in the Siemens 3.6 (left) and Repower 5M (right) turbines

- Weather conditions.** The offshore weather conditions, mainly wind speeds and wave heights, do have a large influence on the O&M procedures of offshore wind farms. However, also fog or tidal flows may influence the accessibility. The maintenance

activities and replacement of large components can only be carried out if the wind speed and wave heights are sufficiently low. Preventive maintenance actions are therefore usually planned in the summer period. If failures occur in the winter season, it does happen that technicians cannot access the turbines for repair actions due to bad weather and this may result in long downtimes and thus revenue losses.

- **Transportation and access vessels.** For the nowadays offshore wind farms, small boats like the Windcat, Fob Lady, or SWATH boats are being used to transfer personnel from the harbour to the turbines. In case of bad weather, also helicopters are being used, see Figure 4. RIB's (Rigid Inflatable Boats) are only being used for short distances and during very good weather situations. The access means as presented in Figure 4 can also transport small spare parts. For intermediate sized components like a yaw drive, main bearing, or pitch motor it is often necessary to use a larger vessel for transportation, e.g. a supply vessel. New access systems are being developed to allow personnel transfer even under harsh conditions. An example which has been developed partly within the We@Sea program is the Ampelmann (www.ampelmann.nl).



Fig. 4. Examples of transportation and access equipment for maintenance technicians; clockwise: Windcat workboat, Fob Lady, helicopter, and SWATH boat

- **Crane ships and Jack-up barges.** For replacing large components like the rotor blades, the hub, and the nacelle and in some cases also for components like the gearbox and the generator, it is necessary to hire large crane ships, see Figure 5.



Fig. 5. Examples of external cranes for replacement of large components; Jack-up barge ODIN (left) and crane ship

- **Vessel and personnel on site all the time.** When going further offshore the time to travel from the harbour to the wind farm will increase, so that the technicians will have only limited production time, may be less than 5 hours. Advantage of having a vessel and personnel on-site all the time is that technicians are able to work a full day. For corrective maintenance this will imply that the total downtime can be reduced while for preventive maintenance less technicians are required. Figure 6 shows an impression of the Sea energy's Ulstein X-bow, which can take 24-36 technicians.

2.2 Types of maintenance

When looking at a general level, maintenance can be subdivided in preventive and corrective maintenance. Corrective maintenance is necessary to repair or replace a component or system that does not fulfil its designed purpose anymore. Preventive maintenance is performed in order to prevent a component or system from not fulfilling its designed purpose. Both preventive and corrective maintenance can be split up further and depending on the type of application different levels of detail are used. In the CONMOW project (Wiggelinkhuizen, 2007, 2008) it is shown that when considering wind turbine technology the following categories seem appropriate, see also Figure 7.

- Preventive maintenance;
 - Calendar based maintenance, based on fixed time intervals, or a fixed number of operating hours;
 - Condition based maintenance, based on the actual health of the system;
- Corrective maintenance;
 - Planned maintenance, based on the observed degradation of a system or component (a component is expected to fail in due time and should be maintained before the actual failure does occur);
 - Unplanned maintenance, necessary after an unexpected failure of a system or component.



Fig. 6. Impression of Sea energy's Ulstein X-bow
(<http://social.windenergyupdate.com/qa/sea-energy-takes-offshore-wind-om-another-level>).

Both condition based preventive maintenance and planned corrective maintenance are initiated based on the observed status or degradation of a system. The main difference between these two categories is that condition based preventive maintenance is foreseen in the design, but it is not known in advance when the maintenance has to be carried out, while the occurrence of planned corrective maintenance is not foreseen at all. This is illustrated by the examples below.

Example condition based preventive maintenance

The oil filter has to be replaced several times during the lifetime of the turbine. To avoid calendar based maintenance the oil filter is monitored and the replacement will be done depending on the pollution of the filter. So it is not the question **if** this maintenance has to be carried out, but **when** it has to be done.

Example planned corrective maintenance

During the lifetime of the turbine it appears that the pitch motors show unexpected wear out and have to be revised in due time to avoid complete failure. Until this revision, if carried out in due time, the pitch system is expected to function properly. On contrary to the example above this type maintenance was initially **not** foreseen, but as it is not necessary to shut down the turbine, the maintenance can be planned such that it can be carried out at suitable moment.

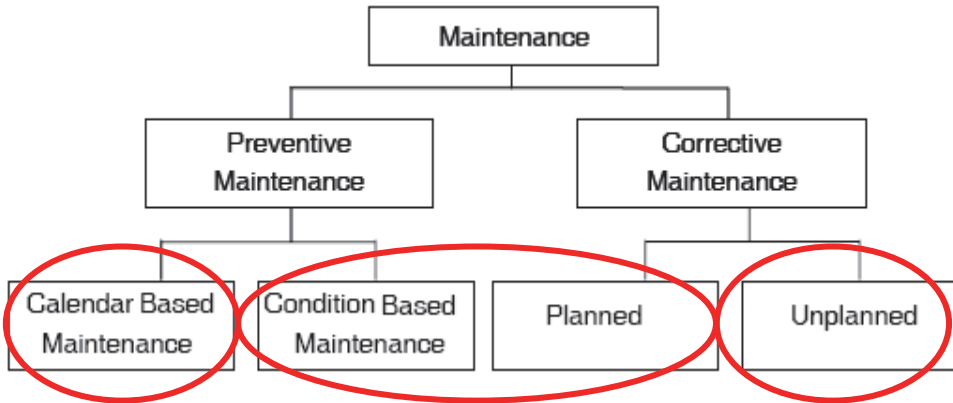

Fig. 7. Schematic overview of the different types of maintenance (Wiggelinkhuizen, 2008).

Considering the limited differences between condition based preventive maintenance and planned corrective maintenance, the planning and execution of both categories will probably be similar in practice. Hence, only three types of maintenance have to be considered:

- Unplanned corrective maintenance
- Condition based maintenance
- Calendar based maintenance

For offshore wind energy, condition based maintenance is preferred above unplanned corrective maintenance since it can be planned on time. Spare parts, crew and equipment can be arranged on time and the turbine can continue running during bad weather conditions. Consequently, revenue losses can be limited.

2.3 Cost estimation

Generally, the costs for maintaining an offshore wind farm will be determined by both corrective and preventive maintenance. In Figure 8, the different cost components are schematically drawn. The O&M costs consist of preventive maintenance costs which are usually determined by one or two visits per year. After 3 or 4 years the preventive maintenance costs can be somewhat higher due to e.g. oil changes in gearboxes. On top of that there are corrective maintenance costs which are more difficult to predict. At the beginning of the wind farm operation the corrective maintenance costs can be somewhat higher than expected due to teething troubles. Finally, it might be that major overhauls (e.g. replacement of gearboxes or pitch drives) are foreseen once or twice per turbine lifetime.

For many technical systems three phases can be identified over the lifetime and this is also schematically drawn in Figure 8.

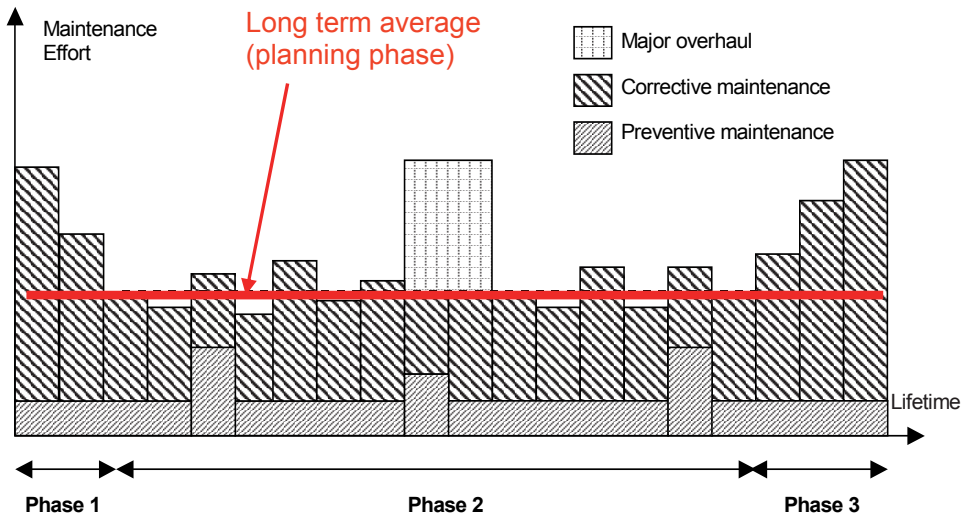

Fig. 8. Schematic overview of the maintenance effort over the lifetime of a turbine. In reality, none of the lines is constant; the actual maintenance effort will vary from year to year.

Phase 1: During the commissioning period, the burn-in problems usually require additional maintenance effort (and thus cost). Time should be spent on finding the right settings of software, changing minor production errors, etc. During this period the maintenance effort usually decreases with time.

The turbine manufacturer usually provides a contract to the customer with a fixed price for the first five years of operation. The contract includes commissioning, preventive and corrective maintenance, warranties and machine damage.

Phase 2: During this phase random failures might be expected, and the failure rate is more or less constant over this period. However in reality the actual maintenance effort will vary from year to year and will fluctuate around the long-term average value, which is displayed in Figure 8 by the red line.

After say about 10 years of operation, it is very likely that some of the main systems of the turbines should be revised, e.g. pitch motors, hydraulic pumps, lubrication systems, etc. With the offshore turbines, no experience is available up to now on how often a major overhaul should be carried out. The exact point in time at which the overhaul(s) should take place is presently not known, perhaps after 7 years, 15 years, or not at all. The major overhaul in fact is to be considered as “condition based maintenance”.

Phase 3: At the end of the lifetime it is likely that more corrective maintenance is required than in the beginning of the lifetime. It is presently unclear how much more this will be.

Figure 8 schematically shows the variation in O&M effort over the years that should be considered to assess the expected costs and downtime. If one is interested in the average O&M costs over the lifetime the yearly variation is not of importance and the annual costs can be determined based on long term average values of failure rate costs, etc. This

approach is used in the O&M Tool and is especially suitable in the planning phase of new project.

It is clear from Figure 8 that the costs in a certain year may deviate significantly from the long term average value. Due to the randomness of the occurrences of failures it may occur that in one year the number of failures is much higher than average and in another year much less. In case the number of failures is higher than average it may occur that the downtime per failure is higher than average due to the unavailability of ships or spares. On the other hand if the number of failures is less than average the cost of equipment per failure may be higher, because of overcapacity. In both situations it is assumed that the number of ships is allocated based on the average failure rate. So if one is interested not only in the average value of the cost but also in expected variation, the cost estimation should be based on the actual occurrences of failures, which can be modelled by means of a Poisson process (Vose) this implies that the cost estimation should be done based on time simulation taking into account operational data, which has been applied in the OMCE-calculator.

3. OMCE project

In this section information is provided on the OMCE project, where the background and objectives are listed, a description of the OMCE model is given and the position of the OMCE within an integral wind farm monitoring system is discussed.

3.1 Background and objectives

As part of the Bsik programme 'Large-scale Wind Power Generation Offshore' of the consortium We@Sea (www.we-at-sea.org) ECN initiated the idea of developing the Operation & Maintenance Cost Estimator as a tool that could be used by operators of large offshore wind farms to monitor the O&M effort for wind farms in operation already and to control the costs of these wind farms for the coming period of e.g. 1,2 or 5 years. To be able to control and subsequently to optimise the future O&M costs of these wind farms, it is necessary to accurately estimate the O&M costs for the next coming period, taking into account the operational experiences available at that moment. Several reasons are present for making accurate cost estimates of O&M of (offshore) wind farms. Examples are:

- to make reservations for future O&M costs (this is especially important for the party who is responsible for the financial management of the maintenance);
- operating experiences may give indications that changing the O&M strategy will be profitable, and then the costs need to be determined accurately in order to compare the adjusted strategy with the original one;
- before the expiration of the warranty period, a wind farm owner needs to decide how to continue with servicing the wind turbines (new contract with turbine supplier or to take over the total responsibility) after the warranty period;
- if a wind farm is going to be sold to another investor, the new owner wants to have detailed information on what O&M costs he can expect in the future.

It may be clear that such a tool with these features is not of interest for operators only, but also for other stakeholders (owners of wind farm, wind turbine manufacturers, etc.).

The above mentioned initiative of ECN resulted in the OMCE-project with the main objective to develop methods and tools that can be used to estimate the future O&M effort and associated costs for the coming period of f.i. 1, 2 or 5 years, taking into account the

operational experiences of the wind farm acquired during the operation of the wind farm so far. The objective is to determine not only the expected values for characteristic O&M parameters, but also to quantify the effect of uncertainties due to the random occurrence of failures, due to variability of the weather conditions, and the due to the uncertainty in the operational data. The O&M Cost estimator is developed in such a way that cost estimates can be made at any point in time during the operational phase. However, it is a prerequisite that at least 2 to 3 years of operational data are available.

The development of the specifications for the OMCE was carried out within the Bsik programme 'Large-scale Wind Power Generation Offshore' of the consortium We@Sea. At the moment that the We@Sea project finished in 2009, the D OWES (Dutch Offshore Wind Energy Services) project (DOWES, Leersum) was started, and within this project the development of the event list and the programming of the OMCE-Calculator is carried out.

3.2 Description of the OMCE model

3.2.1 Overall structure

The OMCE is designed to determine the O&M effort and associated costs for the coming period (say the next 1, 2 or 5 years) taking into account the operational experience available at that moment. That's why two major modules can be distinguished in the overall structure of the OMCE as depicted in Figure 9.

1. The OMCE Building Blocks

To process operational data four so called OMCE Building Blocks (BB) have been specified, each covering a specific data set.

- BB *Operation and Maintenance*;
- BB *Logistics*;
- BB *Loads and Lifetime*;
- BB *Health Monitoring*;

The main objective of these building blocks is to process all available data in such a way that useful information is obtained, which on the one hand can be used for monitoring purposes and which on the other hand can be used to specify the input for OMCE calculator. If convenient other types of building blocks can be included.

2. The OMCE-Calculator

The main objective is to determine the expected O&M effort and associated costs for the coming period, where amongst others all relevant information provided by the OMCE Building Blocks is taken into account. Three types of maintenance are included, viz. calendar based maintenance, condition based maintenance and unplanned corrective maintenance.

3.2.2 Event list

Originally it was assumed that the different data sources would provide enough information to execute the different BB's. However, from previous studies it was concluded that especially the O&M data and the logistics data were **not** available in a format suitable for straightforward further processing. The main reasons for this are:

- During the first few years of operation, operators are not in charge of the maintenance. Although they do receive copies of worksheets, SCADA data, and information on the use of equipment and spare parts, it is in most cases not traceable why certain activities are carried out and how some activities are linked to e.g. alarms or other activities.

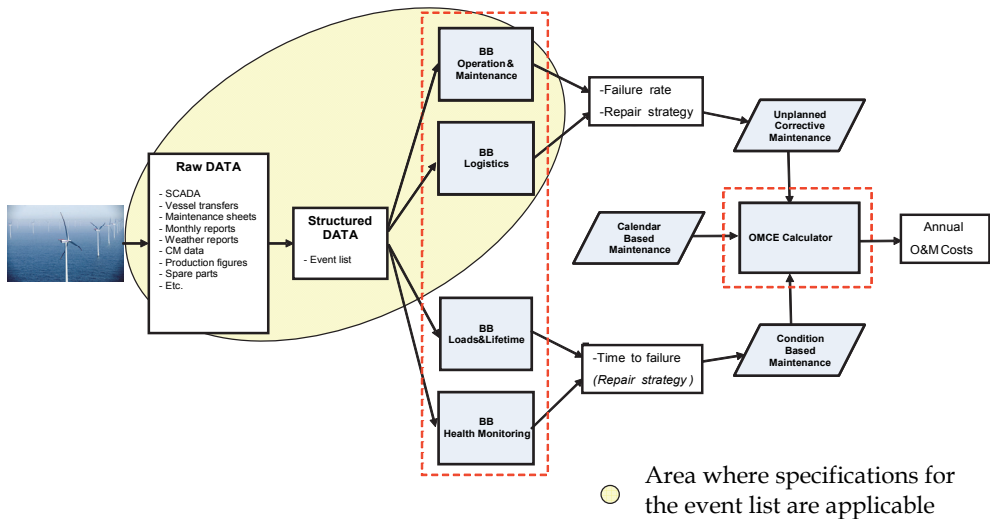

Fig. 9. OMCE concept including the process of structuring the raw data into an event list

- Since the operators are not in charge of the maintenance, there is not really a need to analyse the O&M data in large detail and to determine the cost drivers. In most cases long term contracts are signed with a service provider (usually the turbine supplier). The operator is not forced to analyse the data and thus to set up a structured format for data collection.
- The data are stored in different sources and in different formats, sometimes even handwritten. This makes it difficult to automate the processing, especially because the different data sources are generally not well correlated.

It was concluded that the acquisition of raw data generated by an offshore wind farm should be structured such that the data stored in various data sources are correlated uniquely. Based on the workflow controlled by the maintenance manager of a wind farm, a possible method is outlined for O&M related data. According to this method all O&M related data stored in the different data sources are correlated by means of the “initiating event” for a certain maintenance activity. In case data are collected in such a structured manner it should be possible to extract the so called “event list” from these data sources. Per turbine the event list contains an overview of the different maintenance events that have occurred in chronological order. Per event, relevant issues like the failed component, the trigger for a repair action, the equipment and labour used need to be stored. The event list is meant to structure and classify the raw data in such a way that it can be processed by the OMCE BB’s “Operation and Maintenance” and “Logistics”. For further development of the OMCE it is assumed that raw data can be imported in a relational database and that the event list can be extracted from this database.

3.2.3 Interface between building blocks and calculator

As shown in Figure 9 the OMCE consists of 4 building blocks to process a specific data set each. The objective of processing the operational data is in fact twofold:

1. To provide information to determine or to update the input values needed for the calculation of the expected O&M effort.
2. To provide information that gives insight in the health of the wind turbines, for example by means of trend analyses.

In this report special attention will be given to the first objective in order to specify in more detail what kind of output is expected from the different building blocks in order to generate input for the OMCE-Calculator. It is not expected that the input needed for the calculations can be generated automatically in all cases. The opposite might be true, namely that experts are needed to make the correct interpretations. It is important to realise that there is a difference between the output of the different Building Blocks and the input needed for the OMCE-Calculator. The input needed for the OMCE-Calculator should represent the expected values for the coming period. The various BB's describe the historical situation. If the future situation is similar to the historic situation, the information of the BB's can be used to generate input data for the OMCE-Calculator. If the new situation has changed, the information of the BB's should be used with care or maybe not used at all. Examples of changes are given below.

- The BB's "Operation & Maintenance", "Health Monitoring", and "Loads & Lifetime" generate data (failure rates and expected times to failure) at the level of main systems, components or even (and most preferred) at the level of failure modes. If for instance certain components have been replaced (or will be replaced soon) in all turbines (e.g. by components from different suppliers), the data determined by the various BB's do not necessarily represent the new situation. In the case of failure rates, new estimates need to be made for these components, e.g. by using data from generic databases, or by means of engineering judgement.
- Costs of personnel, equipment, spares, etc are very important input for the OMCE-Calculator to determine the (near) future O&M costs. Most of the cost items are very dependent on the type of contract between operator and e.g. component supplier or maintenance contractor. Such contracts, and thus the prices of spare parts or for renting equipment will change over time. The input for the OMCE should represent the contracts for the next coming period. Analysing the historical costs to generate input data only makes sense if the new situation with new contracts is similar to the historical situation.

So in general it can be said that it is not always necessary to extract all input data from historical data. It is important that the new cost estimates are based on values that represent the future developments best. This means that not all output of the BB's can and will be used as input data for the OMCE-Calculator. The BB's can be used later on to assess if the new situation indeed is an improvement as compared to the historical situation. E.g. the BB "Operation & Maintenance" can be used to verify if the failure rate of a new component indeed is less than the failure rate of the original component. Furthermore it is important to realise that the BB's "Operation & Maintenance", "Health Monitoring", and "Loads & Lifetime" generate data at the level of components or even at the level of failure modes whereas the OMCE-Calculator requires input data at the level of Fault Type Classes (FTC's).

3.3 Integral monitoring and control system

Although the OMCE is being developed as a standalone system it is expected that in the future the OMCE will become part of integral information and decision support systems, f.i.

an IT-system as being developed by Dutch Offshore Wind Energy Services DOWES (Leersum). DOWES is a 4 year research project, which started in May 2009, and will stretch until the end of 2013 and does focus on the development of an integral monitoring and control system. The integration of the DOWES systems is twofold. On one hand the development focuses on the raw data. The envisioned system is a platform which supports and enables the monitoring and control functionalities of (offshore) wind turbines, regardless of the type, manufacturer or capacity of the turbine. On the other hand the development is focused on the integration of data and information obtained and provided by parties in the value chain. This requires current insights and inclusion of detailed processes and information down to the individual users whereas information and decision support on strategic level requires overviews and extensive prognoses on the mid- and long-term.

The position of the OMCE BB's and the OMCE-Calculator within the DOWES portal is schematically depicted in Figure 10. The BB's will be integrated within the IT-system. However, the calculator is positioned as an add-in to the system. The input for the OMCE-Calculator is provided by the system and the results obtained with the OMCE-Calculator are stored in the integral system. In this way both the results of the BB's and the results generated by the calculator can be made available for long-term decision support. For instance when optimization of the O&M strategy has to be considered, several scenarios can be analysed by means of the calculator using data originating from the BB's and other data sources available. After the results of these analyses are stored in the system they can be approached by the user in connection with all kind of other data to decide upon possible improvements in the O&M strategy.

In case the OMCE has to be integrated in a client specific information and decision support system a system similar to Figure 10 can be set up such that the client specific requirements are fulfilled.

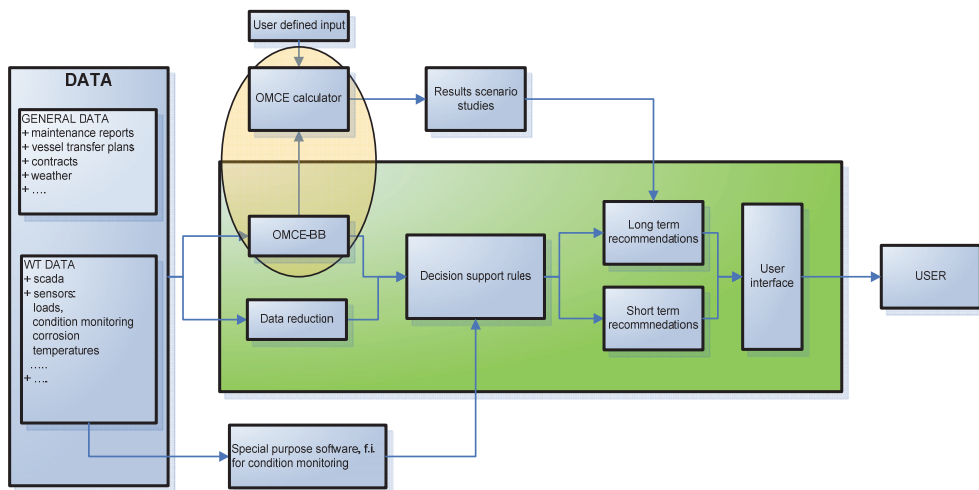

Fig. 10. Structure of the DOWES system for optimising O&M of offshore wind farms in the long and short term making use of wind farm data. The green rectangle represents the portal from which all data sources and models can be approached. The orange oval represents the OMCE-Calculator, which uses the data processed by the OMCE BB's as input.

4. OMCE-Calculator

In this section the functionality and capabilities of the OMCE-Calculator will be discussed in some more detail. In the following sections firstly the starting points for the development of the OMCE-Calculator as presented after which a number of examples are discussed which indicate the functionality of the developed software demo of the OMCE-Calculator.

4.1 Starting points

The main objective of the OMCE-Calculator is to assess the total O&M effort and the associated costs and downtime for the coming period of 1 to 5 years, where all aspects affecting O&M should be considered. Starting point for the OMCE-Calculator are all three types of maintenance described in section 2.2, where at least the following aspects should be included:

- Random occurrence of failures.
- The number of failures in a certain year is a stochastic quantity.
- Failures in different wind turbines may coincide or may happen close together. On the one hand repairs can probably be clustered (f.i. crane ship is mobilised only once to visit a number of turbines) , or on the other hand some repairs need to be postponed due to unavailability of equipment or spares.
- Flexibility w.r.t. maintenance strategies, because different types of failures may require completely different approach.
- For some repairs a sequence of maintenance phases are required. F.i. after a failure of a main component first two inspections have to be made and next the component has to be replaced using a crane ship. After the replacement another inspection has to be made before commissioning can be started. So in total 5 different phases have to be distinguished.
- Some phases have to be completed during one continuous operation, while other phases can be carried out during a number of non successive days. For both situations it should be optional to work in a number of shifts.
- Interaction between three types of maintenance.
- Availability of equipment may vary with time (more equipment is allocated during summer for preventive maintenance, of during certain period in which condition based maintenance is planned).
- Determination of waiting time due to bad weather and calculation of revenue losses should be based on representative weather data. In this way the effect of the inherent variability in weather data on waiting time can be quantified. Furthermore, a realistic estimate of the revenue losses can be made by taking into account the effect of relatively high wind speeds during the waiting period, and relatively low wind speeds during the actual repair.
- Logistic aspects of offshore equipment and spares should be treated such that results can be used for optimisation purposes. Stock control should be optional.
- Uncertainty in input parameters (cost, logistic etc.) may be time dependent, f.i. when considering a period of three years, the uncertainty in year three probably is higher than in year one).
- Reliability of wind turbines may be dependent on the location within the wind farm, f.i. the failure behaviour of a wind turbine always operating in the wake may differ from a wind turbine located at the edge of the wind farm, where this difference generally will not be the same for all components.

Considering these requirements it is clear that when analysing future O&M one has to deal amongst others with the random occurrence of failures, the stochastic nature of the weather conditions and furthermore a number of input variables are not known accurately but show some uncertainty. Because the OMCE-Calculator is meant to make estimations for a relatively short period (1 to 5 years) and because the random occurrence of failures in combination with the actual weather conditions has to be taken into account, it may be obvious to develop a time based simulation model and to quantify the uncertainties by carrying out a (large) number of simulations. To model the simulation process an integral maintenance plan will be elaborated as a function of time, taking into account the interaction between the different maintenance types, the simultaneous maintenance actions on different wind turbines, and the availability of resources.

4.2 Examples

To illustrate the capabilities of the OMCE-Calculator software a number of examples are presented. These examples are not representative for an entire wind farm, but are specifically defined to show how the OMCE-Calculator output can be used to optimise O&M on an operational wind farm. This paragraph will focus on the following 3 examples:

1. Consider limitations in stock control of spare parts for unplanned corrective maintenance and use this information to optimise the number of components on stock with respect to downtime of the turbines in the wind farm.
2. Consider limitations in vessels available for unplanned corrective maintenance and determine the optimal number of vessels to buy or hire with respect to total O&M costs of the wind farm.
3. Perform condition based maintenance in the wind farm with different amounts of dedicated equipment and show the advantage of having multiple vessels with respect to the maintenance planning period.

4.2.1 Stock size optimisation

To illustrate how the limitations in the number of spare parts available influence the downtime of the turbines in the wind farm, a simplified example is analysed. The objective of this example is to investigate the relation between the number of spare parts in stock, the total downtime, and to determine the optimal stock size. This example has the following significant inputs:

- 12 wind turbines
- Failure rate per turbine = 2/year
- Historical wind and wave data at the 'Munitiestortplaats IJmuiden' is used to determine site accessibility and revenues
- A work day has a length of 10 hours and starts at 6:00 am.
- 1 system with 1 fault type class for unplanned corrective maintenance, 1 corresponding repair class and 1 corresponding spare part
- The repair class will contain a maintenance event with 1 mission phase (repair) which can be split up in time.
- The reordering time of the spare part is set at 720 h (approximately 1 month), which is much higher than the logistic time to transport the spare part from the warehouse to the harbour at 2 h.
- The simulation will be run for a simulation period of 1 year with a start-up period of 1 year. The number of simulations performed is set at 100 to obtain statistically significant results with respect to the downtime.

If the failure distribution were to be uniform in time, then logically the number of failures will require 2 spare parts per month. With a reordering time of 1 month, a stock size of 2 spares would be sufficient. However, the failure distribution is a Poisson distribution. Now by varying the stock size from 1 to 12 the relation between the stock size and the total downtime of turbines in the wind farm can be set-up. A stock size of 0 spare parts is simulated by disabling stock control and increasing the logistic time to 722 h, while similarly an infinite stock size is simulated by simply disabling stock control and setting only the logistic time at 2 h. The simulation results are depicted in Figure 11.

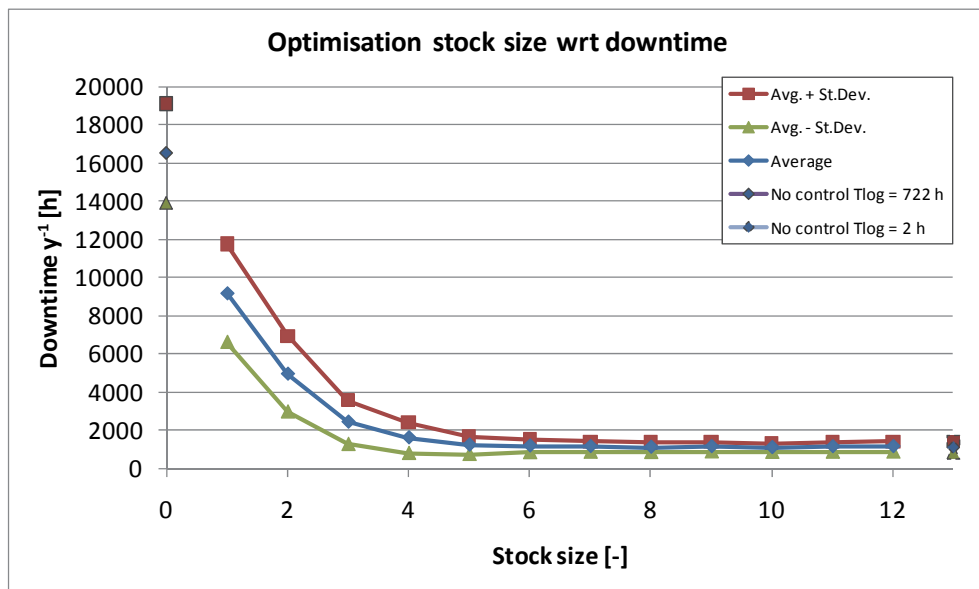

Fig. 11. Results of stock size variation vs. total downtime of wind turbines

In the graph it can now be seen that for this example when 6 or more spares are kept in stock, both the average downtime and the standard deviation in the results seem to converge to the static value obtained without stock control (the data points for 'no control $T_{log} = 2$ h'). The remainder of the downtime at this point is a combination of remaining logistic downtime, waiting time for a suitable weather window and repair time (the applied vessel for maintenance does not have mobilisation time).

Based on these observations the advantages of having spare parts (with high reordering time) in stock for components which fail frequently become very clear and can be quantified with the output of the OMCE-Calculator.

4.2.2 Equipment optimisation

To illustrate how the limitations in the number of vessels available for unplanned corrective maintenance influence the downtime of the turbines in the wind farm, a second simplified example is programmed in the OMCE-Calculator. Now the objective of this second example is to investigate the relation between the number of vessels available and the total downtime. This example has the following significant inputs:

- 50 wind turbines
- Failure rate per turbine = 5/year
- Historical wind and wave data at the ‘Munitiestortplaats IJmuiden’ is used to determine site accessibility and revenues
- A work day has a length of 10 hours and starts at 6:00 am.
- 1 system with 1 fault type class for unplanned corrective maintenance, 1 corresponding repair class and 1 corresponding spare part
- The repair class will contain a maintenance event with 1 mission phase ‘Repair’, where 6 hours of work with 2 technicians are required.
- The vessel used for the repair will be of the ‘support vessel’ type, which can only apply maintenance on a single wind turbine with a single crew when it travels to and from the wind farm. The travelling time of this equipment is set at 1 hour. The mobilisation time of this vessel will be set at 0 hours. In addition to hourly cost and fuel surcharges, fixed yearly cost of 250 k€ are assigned to each vessel.
- The simulation will be run for a simulation period of 1 year with a start-up period of 1 year. The number of simulations performed is set at 100 to obtain statistically significant results with respect to downtime and energy production.

The input details for the equipment defined are also shown in Table 1.

Project:		Equipment 1														
Equipment no.	Type	Name														
1	Support vessel	Support 1												Unplanned corrective	Condition based	Calendar based
	Logistics & availability	Unit	Input	Weather limits		Unit	Input	Cost	Unit	Input	Input	Input	Input	Input	Input	
	Mobilisation time	h	0	Wave height	Travel	m	2	Work	Euro/h		300	300	300	0	0	
	Demobilisation time	h	0		Transfer	m	2		Euro/day		0	0	0	0	0	
	Travel time	h	1		Positioning	m	2		Euro/mission		0	0	0	0	0	
	Max. technicians	-	6		Hoisting	m	2	Wait	Euro/h		0	0	0	0	0	
	Transfer category	-	single crew	Wind speed	Travel	m/s	12		Euro/day		0	0	0	0	0	
	Travel category	-	daily		Transfer	m/s	12		Euro/mission		0	0	0	0	0	
	Vessels available corrective	-	1		Positioning	m/s	12	Fuel surcharge per trip	Euro/trip		300	300	300	0	0	
	Vessels reserved condition	-	0		Hoisting	m/s	12	Mob/Demob	Euro/mission		0	30000	30000	0	0	
	Vessels reserved calendar	-	0					Fixed yearly	Euro/day		250000	250000	250000	0	0	

Table 1. Reflection of equipment input optimisation project (1 equipment available)

Although the example objective is similar to the example as discussed in section 0, the results are assumed to be different. The example inputs are set such that the average amount of failures will approximate to 250 per simulation. If these 250 failures were to occur independently on days where the defined support vessels’ weather limits are sufficient to carry out all of the work, it would theoretically be possible to service the entire wind farm with 1 vessel. However, the failures follow the Poisson distribution and the weather limits set for this vessel are relatively strict with respect to the measured wave heights and wind velocities. This is expected to lead to a large increase in resource-related downtime if only 1 vessel were to be available to perform maintenance.

Now, by varying the number of available support vessels from 1 to 6, the relation between the number of vessels available and the total downtime of wind turbines can be set-up. The simulation results are depicted in Figure 12. We see that if only one vessel is available, than the average total downtime is more than doubled compared to the case when there are 2 vessels available. From 4 vessels onward, the decrease in downtime due to a lack of resources becomes smaller.

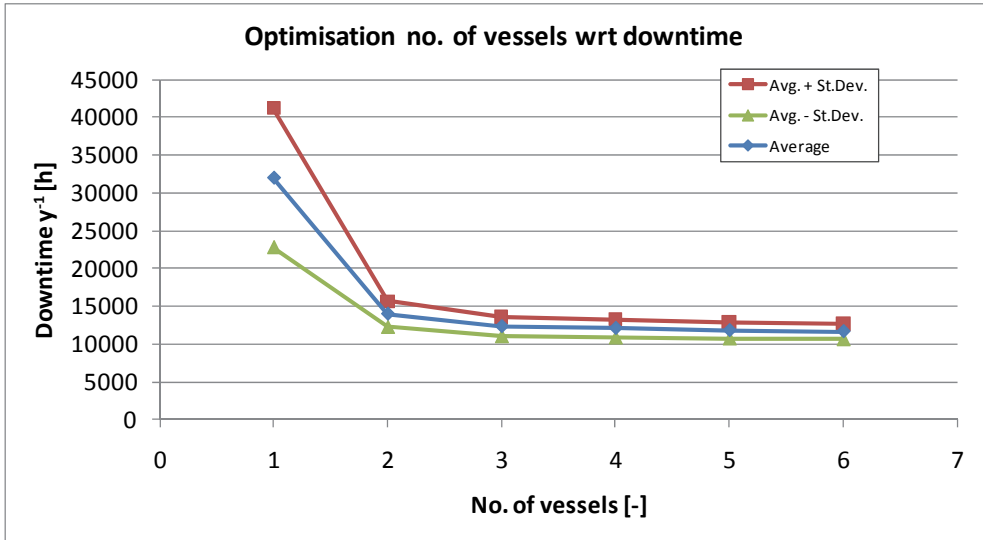

Fig. 12. Results of variation of no. of available vessels vs. total downtime of wind turbines

Although the number of available vessels with respect to downtime should be as high as possible to prevent revenue losses due to a lack of resources, additional vessels will require additional O&M investments. The optimum number of vessels available for a wind farm should be related to the increase in repair costs and the decrease in revenue losses. The number of available vessels with respect to repair costs and revenue losses is now plotted in Figure 13.

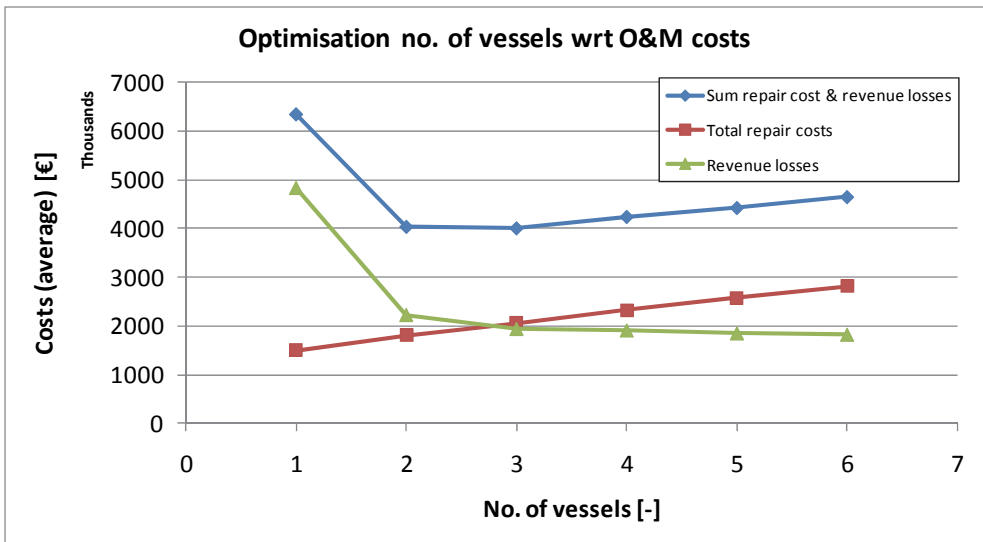

Fig. 13. Sum of total O&M cost and revenue losses as a function of no. of available vessels

In Figure 13 the trend of the revenue losses versus the number of available vessels is decreasing, which naturally resembles the trend in downtime of wind turbines in the wind farm. At the same time, the total repair cost is increasing almost linearly with respect to the number of vessels. To plot the total O&M cost, both the repair cost and the revenue losses are super-positioned leading to the blue line in the graph. Based on the sum of these repair cost and revenue losses, the optimum number of vessels for the proposed example is seen to be 3 support vessels, since the effect of having more than 3 vessels on the overall downtime (and thus revenue losses) is negligible and the cost of having those vessels available increases.

Based on the above observations we can conclude that with the output of the OMCE-Calculator demo it is possible to quantify the effect on downtime & costs and to optimise the number of vessels available to perform corrective maintenance.

4.2.3 Implementing condition based maintenance

One of the additional features of the OMCE-Calculator is the ability to model condition based maintenance. One of the main modelling assumptions is that the maintenance events can be planned in advance and the turbines will only be shut down during the actual repairs made. A period can be specified during which equipment is available for condition based maintenance. In case the work cannot be completed within this period, e.g. due to bad weather conditions or shortage of equipment a message will be given by the program (N.B. the number of repairs will be constant for each simulation, the random year chosen in the weather data will not). It can then be considered to allocate more equipment or to lengthen the period.

The current example will demonstrate the modelling of condition based maintenance in relation to the defined maintenance period and the number of equipment available. The objective is to model the same maintenance with 1 vessel available per equipment type and 2 vessels available per equipment type, after which the results can be compared with respect to the planned maintenance period and equipment cost. This example has the following significant inputs:

- 50 wind turbines
- Number of repairs to be made (no. of turbines) = 10
- Historical wind and wave data at the 'Munitiestortplaats IJmuiden' is used to determine site accessibility and revenues
- A work day has a length of 10 hours and starts at 6:00 am.
- 1 system with 1 fault type class for condition based maintenance and 1 corresponding spare control strategy
- The repair class will contain a maintenance event with the phase 'Replacement', where in total 16 hours of work with 4 technicians are required.
- The type of vessels used for the replacement are: 'Access vessel' and 'Vessel for replacement'. The travelling time of the access vessel is set at 1 hour, while the travelling time of the vessel for replacement is set at 4 hours. The vessel for replacement is assumed to have an overnight stay in the wind farm. Apart from the hourly cost and fuel surcharges, a mob/demob cost is added to both vessels.
- The maintenance period window is set from 1st of July up to and including the 31st of July.
- The simulation will be run for a simulation period of 1 year with a start-up period of 1 year. The number of simulations performed is set at 100 to obtain statistically significant results with respect to downtime and energy production.

The equipment input parameters are also displayed in Table 2.

Project: Condition based maintenance 1															
Equipment no.	Type	Name													
1		Access vessel	Swath workboat					Unplanned corrective						Condition based	Calendar based
		Logistics & availability	Unit	Input	Weather limits	Unit	Input	Cost	Unit	Input	Input	Input	Input		
	Mobilisation time	h		0	Wave height	Travel	m	2	Work	Euro/h	0	300	300		
	Demobilisation time	h		0		Transfer	m	2		Euro/day	0	0	0		
	Travel time	h		1		Positioning	m			Euro/mission	0	0	0		
	Max. technicians	-		5		Hoisting	m		Wait	Euro/h	0	0	0		
	Transfer category	-	multiple crews		Wind speed	Travel	m/s	12		Euro/day	0	0	0		
	Travel category	-	daily			Transfer	m/s	12		Euro/mission	0	0	0		
	Vessels available corrective	-		1		Positioning	m/s		Fuel surcharge per trip	Euro/trip	0	300	300		
	Vessels reserved condition	-		1		Hoisting	m/s		Mob/Demob	Euro/mission	0	25000	25000		
	Vessels reserved calendar	-		0					Fixed yearly	Euro/day	0	0	0		
2		Vessel for replacement	Crane ship					Unplanned corrective						Condition based	Calendar based
		Logistics & availability	Unit	Input	Weather limits	Unit	Input	Cost	Unit	Input	Input	Input	Input		
	Mobilisation time	h		16	Wave height	Travel	m	2	Work	Euro/h	0	10000	0		
	Demobilisation time	h		8		Transfer	m	2		Euro/day	0	0	0		
	Travel time	h		4		Positioning	m	2		Euro/mission	0	0	0		
	Max. technicians	-		0		Hoisting	m	2	Wait	Euro/h	0	0	0		
	Transfer category	-	single crew		Wind speed	Travel	m/s	8		Euro/day	0	0	0		
	Travel category	-	stay			Transfer	m/s	8		Euro/mission	0	0	0		
	Vessels available corrective	-		1		Positioning	m/s	8	Fuel surcharge per trip	Euro/trip	0	5000	0		
	Vessels reserved condition	-		0		Hoisting	m/s	8	Mob/Demob	Euro/mission	0	25000	0		
	Vessels reserved calendar	-		0					Fixed yearly	Euro/day	0	0	0		

Table 2. Reflection of equipment input condition based maintenance project

Based on the input parameters the minimum time required to fulfil 1 condition based maintenance repairs is exactly 2 work days. If the weather conditions are calm, it should be possible to perform all condition based repairs within the given maintenance period. However, the weather window limits for hoisting are set fairly strict and the weather pattern in the North Sea is known to be variable even in the summer periods.

Two different simulation runs have now been performed, the first run has 1 vessel available for both equipment types, the ‘access vessel’ and the ‘vessel for replacement’, while the second run has 2 vessels available for each equipment type. To determine whether or not the maintenance could be performed within the given maintenance period, the graph output of the OMCE-Calculator is used. Two cumulative distribution function (CDF) plots are shown in Figure 14. The CDF plot y-axis represents the fraction of simulations where the corresponding x-axis value (no. of events outside period) is below a certain value. So in this example 13% of the simulations result in all maintenance events finishing within the simulation period when there is 1 vessel available of each equipment type (left CDF plot in Figure 14). We also see that when there are 2 vessels available, than 85% of the simulations do finish within the simulation period (right CDF plot in Figure 14).

However, having additional vessels will not decrease in the revenue losses (turbines are only shut down during maintenance) and at the same time there may be an increase in equipment cost. Engineering judgement will be required to determine whether or not additional delays are allowable with respect to the remaining lifetime of the components which should be replaced.

Based on the above observations we can conclude that with the output of the OMCE-Calculator demo it is possible to quantify condition based maintenance replacements and to set a specific maintenance period when this maintenance should be performed. However, notice that the OMCE-Calculator demo is not intended to be used as a program to optimise maintenance planning in time. The output should rather be used by the maintenance engineer as a first indication whether or not a certain maintenance scenario is feasible to perform in a given time frame.

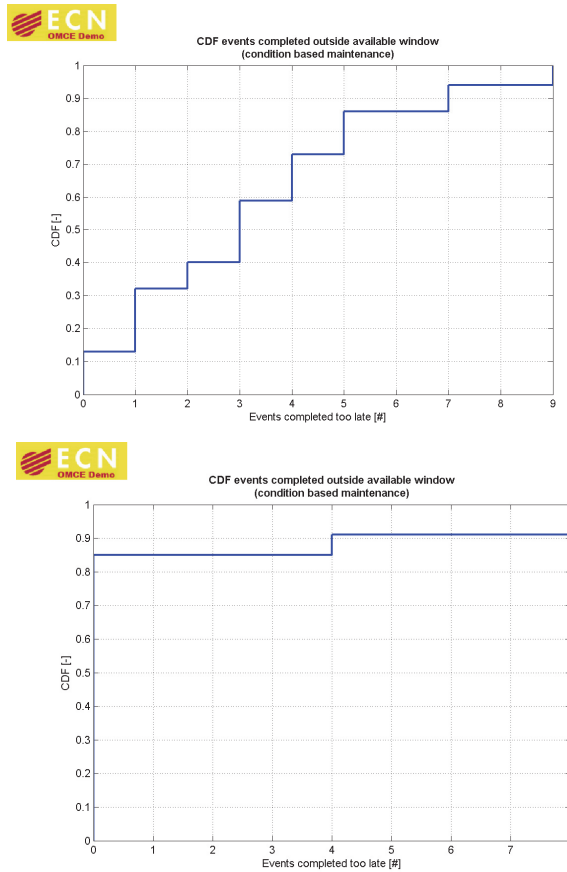

Fig. 14. CDF plot of number of maintenance events performed outside required maintenance period; Simulations with 1 vessel available (left) and simulations with 2 vessels available (right)

5. OMCE-Building blocks

As was shown in Figure 9 the OMCE consist of four Building Blocks (BB) to process each a specific data set. Furthermore, it was also mentioned that the Building Blocks in fact have a two-fold purpose:

1. To provide information to determine or to update the input values needed for the calculation of the expected O&M effort with the OMCE-Calculator.
2. To provide more general information on the wind farm performance and 'health' of the wind turbines.

The Building Blocks 'Operation & Maintenance' and 'Logistics' have the main goal of characterisation and providing general insight in the corrective maintenance effort that can be expected for the coming years. With respect to corrective maintenance important aspects are the failure frequencies of the wind turbine main systems, components and failure

modes. Furthermore, other parameters that are needed to describe the corrective maintenance effort are for instance the length of repair missions, delivery times of spare parts and mobilisation times of equipment.

As mentioned already in section 3.1.2 the format used by most wind farm operators for storage of data is not suitable for automated data processing by these Building Blocks. Usually, operators collect the data as different sources. In order to enable meaningful analyses with both Building Blocks 'Operation & Maintenance' and 'Logistics' these different sources need to be combined into a structured format. For this purpose an Event List format has been developed, in which the various 'raw' data sources are combined and structured (see also Figure 9).

For estimating the expected future condition based maintenance work load the Building Blocks 'Loads & Lifetime' and 'Health Monitoring' have been developed. The main goal of these Building Blocks is to obtain insight in the condition or, even better, remaining lifetime of the main wind turbine systems or components.

The expected preventive (or calendar based) maintenance work load is not something that will be estimated using the OMCE Building Blocks since this effort is generally well-known and specified by the wind turbine manufacturer.

In this report special attention will be given to the first objective in order to specify in more detail what kind of output is expected from the different Building Blocks in order to generate input for the OMCE-Calculator. It is not expected that the input needed for the calculations can be generated automatically in all cases. The opposite might be true, namely that experts are needed to make the correct interpretations. Furthermore it is also essential to keep in mind that the output of the Building Blocks (based on the analysis of 'historic' operational data) is not always equal to the input for the OMCE-Calculator (which aims at estimating the future O&M costs).

In the following subsections some examples for the Building Blocks "Operation & Maintenance", "Logistics" and "Loads & Lifetime" are presented.

5.1 Operation & maintenance

As has been mentioned in the first part of this section the OMCE-Building Blocks serve a twofold purpose. When looking at BB "Operation & Maintenance" it can be stated that on the one hand it should be suitable for general analyses, which can provide the user of the program with a general overview of the performance and health of the offshore wind farm with respect to failure behaviour. On the other hand the program should provide the possibility of analysing the Event List data in such a way that it can be determined if the failure frequencies used for making O&M cost estimates with the OMCE-Calculator are in accordance with the observed failure behaviour.

Using this Building Block basically two types of analyses can be performed; ranking and trend analysis. In Figure 15 a typical output of the ranking analysis is shown, where the number of failures are shown per main system. This type of output makes it easy to identify possible bottleneck systems. Similar pie charts can be plotted of the failures per (cluster of) turbines. This information could be used to identify whether f.i. the heavier loaded turbines (as could be determined with Building Block 'Loads & Lifetime') also show more failures.

In Figure 16 another example is given of the output of the ranking analysis of the Building Block 'Operation& Maintenance'. Here, for one of the main systems, the distribution of the failures over the defined Fault Type Classes (which indicate the severity of a failure) is

shown. This information can be directly compared with the input data for the OMCE-Calculator and serve as input for the decision whether the original assumptions in the OMCE-Calculator input should be updated or not.

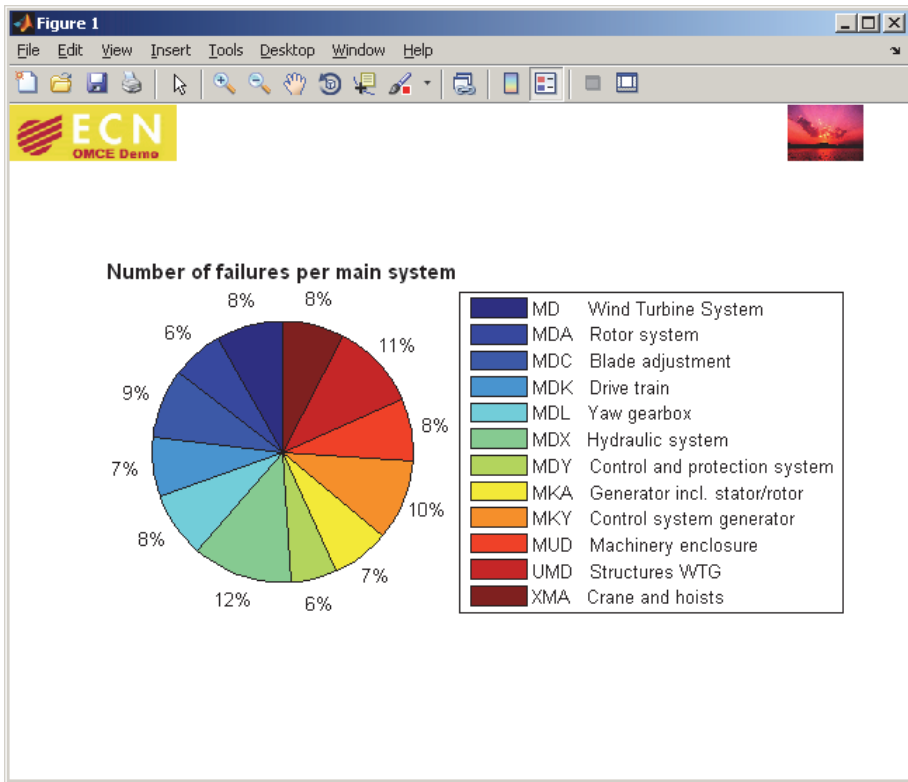

Fig. 15. Example of the output of the ranking analysis of OMCE Building Block 'Operation & Maintenance': Number of failures per main system.

In Figure 17 a typical output of the trend analysis of building block O&M is displayed. The graphs shows, for a selected main system, the cumulative number of failures as function of the cumulative operational time.

The slope of the graph is a measure for the failure frequency. The software allows the user to specify the confidence interval and the period over which the failure frequency should be calculated. This is important when considering that the historical failure behavior does not always have to be representative for the future, which is modeled with the OMCE-Calculator. For instance, when after two years a retro-fit campaign is performed for a certain component, the failures which occurred during the first two years should not be included in the analysis with the goal of estimating the failure rate for the coming years.

In this example the failure frequency is calculated over the period starting at 250 and ending at 350 operational years. The resulting average failure frequency is indicated by the blue line, whereas the 90% confidence intervals are shown by the red dotted lines. The calculated upper and lower limits (Davidson) can be compared with the failure frequency which is

used as input in the OMCE-Calculator. If this value lies outside the calculated boundaries it is recommended to consider adjusting the input for the OMCE-Calculator. If the OMCE-Calculator allows for stochastic input, the average and upper and lower confidence limits can be specified directly as input.

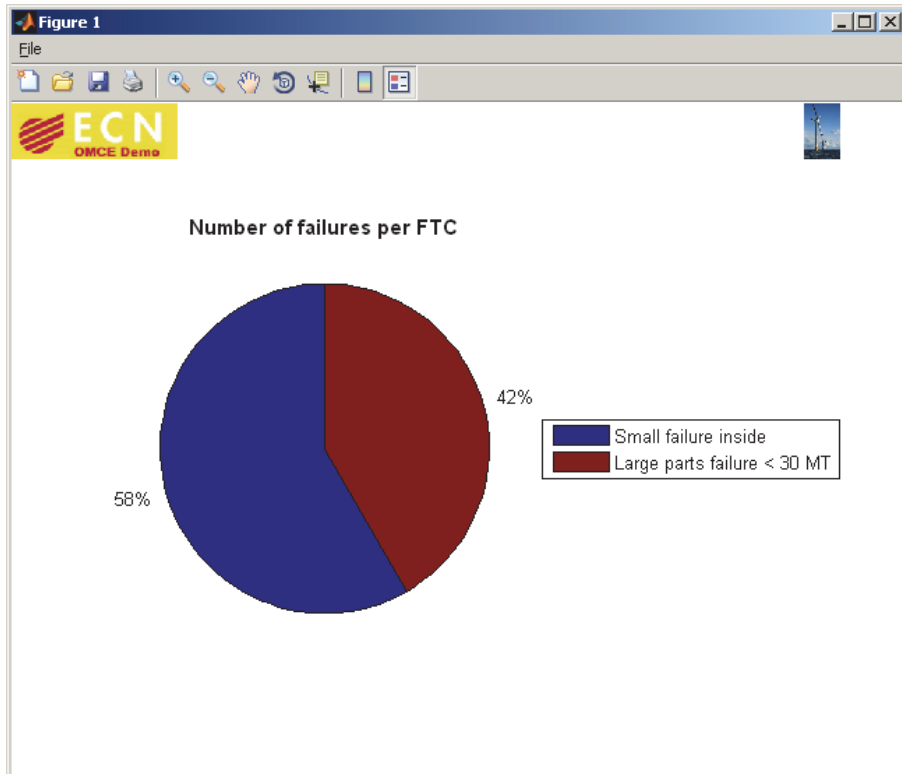

Fig. 16. Example of the output of the ranking analysis of OMCE Building Block 'Operation & Maintenance': Number of failures per FTC.

5.2 Logistics

Similar to the objectives of Building Block "Operation & Maintenance" the objective of the BB "Logistics" is twofold. Firstly this Building Block is able to generate general information about the use of logistic aspects (equipment, personnel, spare parts, consumables) for maintenance and repair actions. Secondly, the Building Block is able to generate updated figures of the logistic aspects (accessibility, repair times, number of visits, delivery time of spares, etc.) to be used as input for the OMCE Calculator.

In the remainder of this section some examples of the demo version of the software of the Building Block 'Logistics' are shown.

The first submenu, for characterisation of the Repair Classes for the OMCE-Calculator, is shown in Figure 18. On the left part of the menu the analysis options can be specified. Here the main system, Fault Type Class and maintenance phase (e.g. remote reset, inspection, repair or replacement) can be selected. Furthermore, boundaries can be set on the

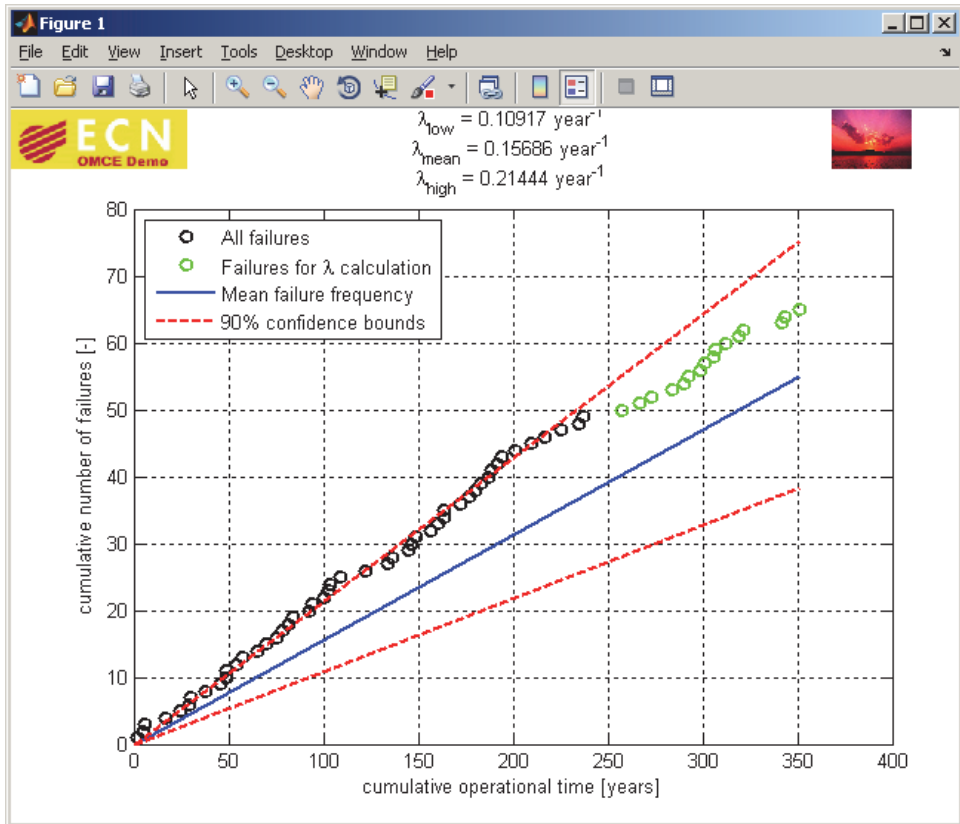

Fig. 17. Example of the output of the trend analysis of OMCE Building Block 'Operation & Maintenance'.

occurrence dates of the failures. This is useful if for instance at a certain date a change in the repair strategy has been implemented. In order to assess whether the 'new' repair strategy is in line with the input data for the OMCE-Calculator, the recorded failures where the 'old' repair strategy was still applied should not be included in the analysis with this Building Block.

On the right part of the menu the results are displayed in two tables. The upper table shows the average, standard deviation, minimum and maximum for time to organise, duration and crew size for the selected analysis options. The bottom table shows the usage of equipment. Furthermore also the number of records/failures that correspond to the selected analysis options are listed.

In Figure 19 an example of the graphical output of the Building Block is presented. In this figure a cumulative density function (CDF) is shown of the duration of a small repair on the generator. This type of information gives additional insight in the scatter surrounding the average value. Furthermore, the information in the graph can also be used to determine whether, in this example, the duration of the repair should be modelled as a stochastic quantity in the OMCE Calculator and, if so, what distribution function (e.g. normal, etc.) is most appropriate.

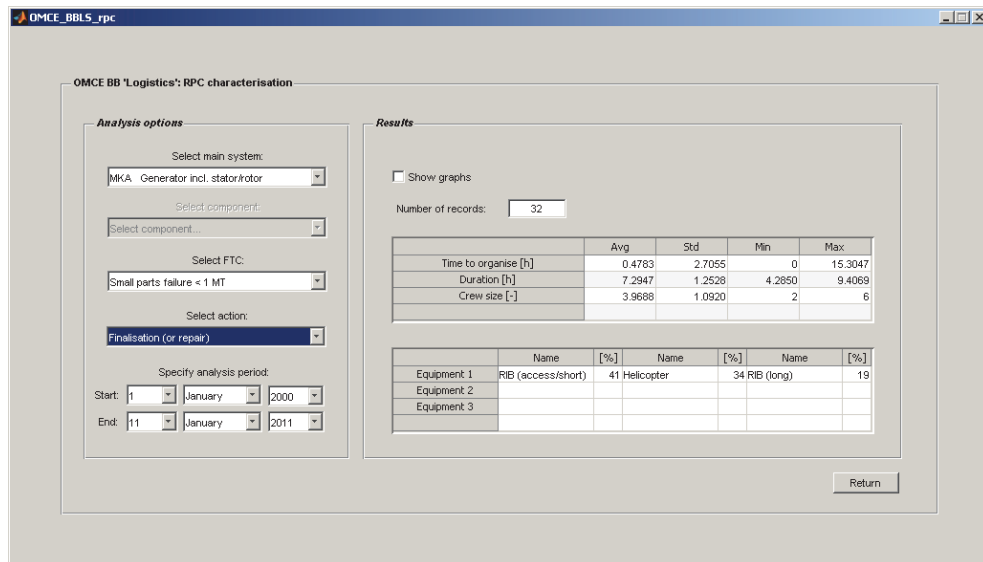

Fig. 18. Submenu for RPC characterisation of the Building Block 'Logistics'.

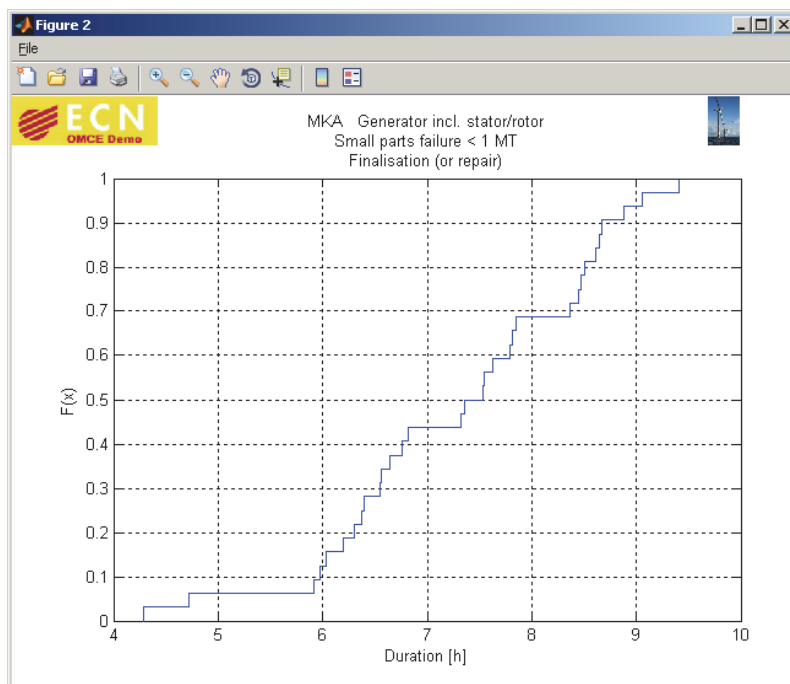

Fig. 19. Example of the output of the RPC characterisation of the Building Block 'Logistics'. Here the CDF of the duration of a small repair on the generator is shown.

In Figure 20 another example is shown. Here the usage of equipment is visualised for a selected Repair Class. The graph illustrates that in total five failures have been recorded which represent a large replacement of a drive train component. It can be seen that for access three different vessels have been used; once a RIB, twice a large access vessel and twice a helicopter. Furthermore, twice a crane ship and three times a jack-up barge has been used for hoisting the components.

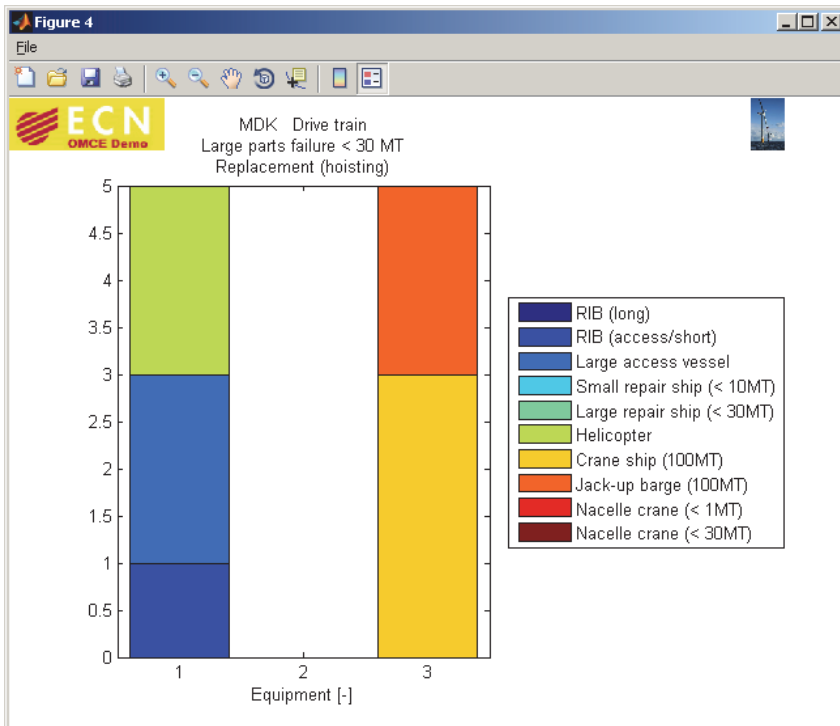

Fig. 20. Example of the output of the Repair Class (RPC) characterisation of the Building Block 'Logistics'. Here the usage of equipment is shown for a large replacement of the drive train.

5.3 Loads & lifetime

As mentioned before the Building Blocks 'Loads & Lifetime' and 'Health Monitoring' are used to make estimates of the degradation, or even better, the remaining lifetime of the main wind turbine components. The main goal of the Building Block 'Loads & Lifetime' is to keep track of the load accumulation of the main wind turbine components and to combine this information with other sources (e.g. condition monitoring systems, SCADA information, results from inspections, etc.) in order to assess whether (and on which turbines) condition based maintenance can be performed.

Previous research has shown that the power output of a turbine, and more importantly, the load fluctuations in a wind turbine blade, strongly depend on whether a wind turbine located in a farm is operating in the wake of other turbines or not. These observations imply

that the loading of the turbines located in a large (offshore) wind farm is location specific; the turbines located in the middle of the farm operate more often in the wake of other turbines compared to the turbines located at the edge of the wind farm. Therefore, it is expected, that during the course of the lifetime of the wind farm certain components will degrade faster on the turbines experiencing higher loading, compared to the turbines subject to lower loading.

This kind of information could be a reason to adjust maintenance and inspection schemes according to the loading of turbines, instead of assuming similar degradation behaviour for all turbines in the farm. When a major overhaul of a certain component is planned the turbines on which the specific component has experienced higher load can be replaced first, whereas the replacement of the component on the turbines which have experienced lower loading can be postponed for a certain time. This approach could result in important O&M cost savings.

In order to monitor the load accumulation in a wind farm in a cost-efficient manner the so-called 'Flight Leader' concept has been developed in order to make estimates of the accumulated loading on the critical components of all turbines in an offshore wind farm. The basic idea behind the Flight Leader concept is that only a few turbines in an offshore wind farm are equipped with mechanical load measurements. These are labelled the 'Flight Leaders'. Using the measurements on these Flight Leader turbines relations should be established between load indicators and standard SCADA parameters (e.g. wind speed, yaw direction, pitch angle, etc.), which are measured at all turbines. Once such relationships are determined for the reference turbines in a wind farm (the Flight Leaders) these can be combined with SCADA data from the other turbines in the wind farm. This enables the determination of the accumulated loading on all turbines in the farm. This is illustrated in Figure 21.

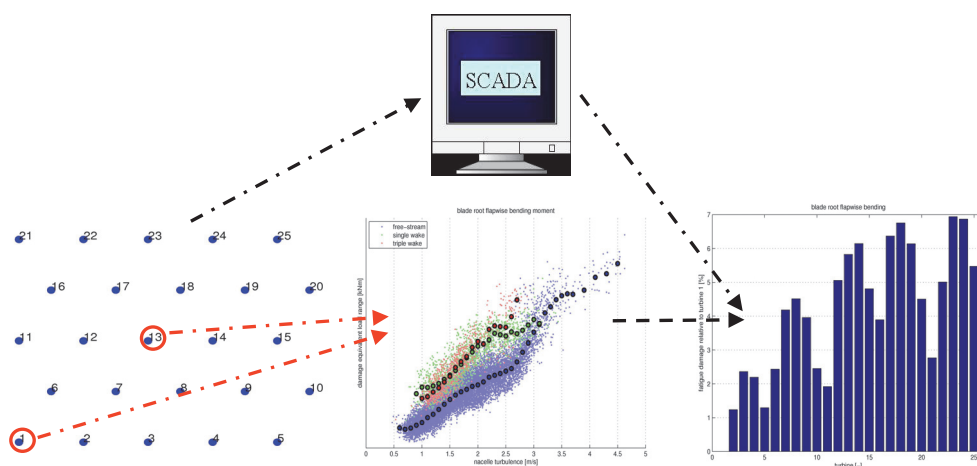

Fig. 21. Illustration of the Flight Leader concept; the load measurements performed on the Flight Leader turbines (indicated by the red circles) are used to establish relations between load indicators and standard SCADA parameters; these relations are combined with the SCADA data from all other turbines in the wind farm in order to estimate the accumulated loading of all turbines in the farm.

The proof-of-concept study and the development of a demo software tool of the Flight Leader was performed in a separate project. The results were reported in a number of publications (Obdam 2009a, 2009b, 2009c, 2010) and in a public report (Obdam, 2010). Therefore in this section only some brief information about the possible output of the Flight Leader software is provided.

The main output of the Flight Leader software consists of a comparison of the accumulated mechanical loading of all turbines in the offshore wind farm under consideration. This output needs to be shown for the different load indicators (e.g. blade root bending, tower bottom bending or main shaft torque). This information, possibly combined with information from BB “Health Monitoring” could be used to specify the input for condition based maintenance in the OMCE-Calculator, or, for a certain component, adjust the failure frequency between the different turbines in the farm according to their accumulated loading.

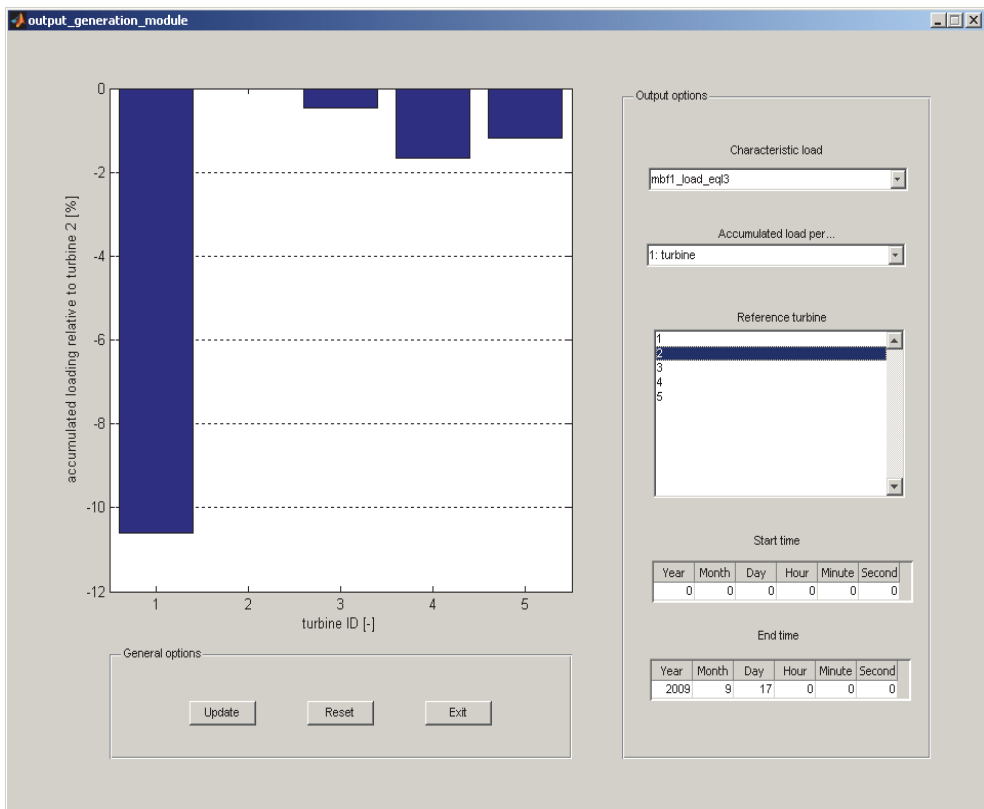

Fig. 22. Example of the output generation model of the Flight Leader software, where the relative (to turbine 3) load accumulation of all turbines is displayed.

Besides the main output the software model can calculate and display various breakdowns of the accumulated loading. For instance the contribution of each turbine state or transitional mode or wake condition to the total accumulated loading can be displayed. Furthermore the load accumulation per time period can be studied. These outputs can be used to get more insight in the performance of the offshore wind farm and what operating conditions have the largest impact on the loading of the turbines in the offshore wind farm. An example of such output is depicted in Figure 23.

Based on these two examples it can be concluded that the Flight Leader software does meet the two-fold criteria of the OMCE Building Blocks: It can generate specific information that could be used to generate or update input for the OMCE-Calculator but it can also be applied to obtain a general insight in the performance of the different wind turbines in the offshore wind farm.

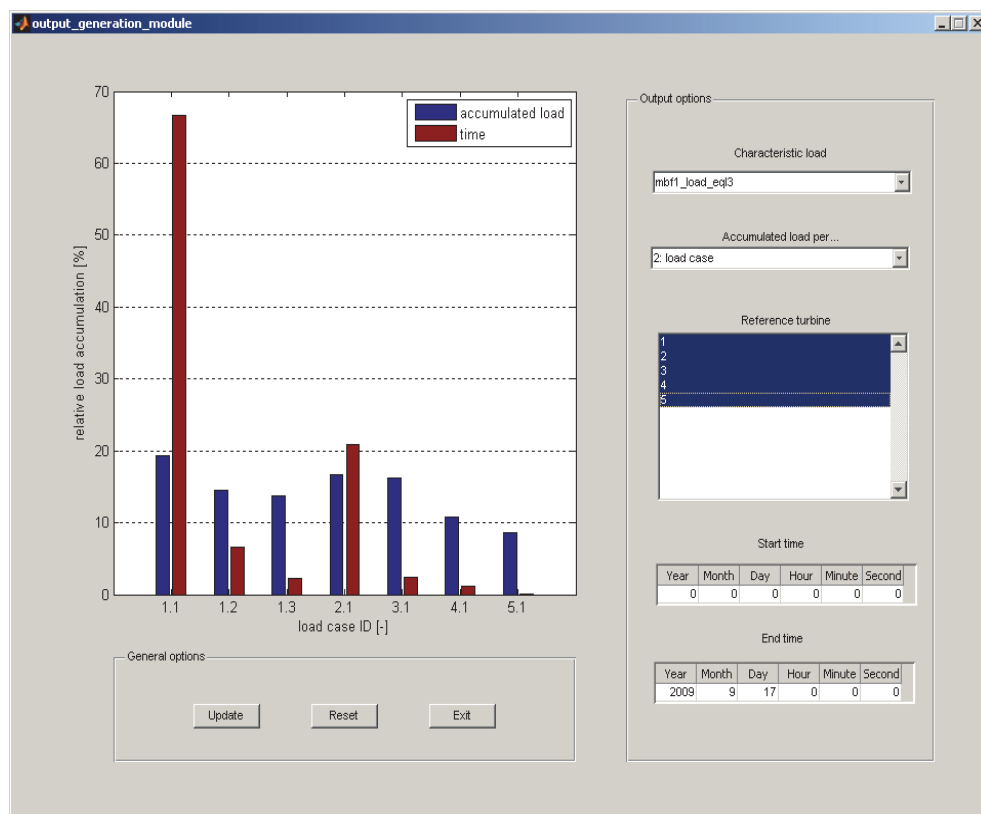

Fig. 23. Example of the output generation model of the Flight Leader software, where the contribution of each load case to the total load accumulation is shown.

6. Conclusion

Operation & Maintenance costs for offshore wind farms are high and contribute significantly to the cost-of-energy of offshore wind energy. In order to make offshore wind energy economically feasible in the long-term, the control and optimisation of O&M is essential. For this purpose ECN developed the ECN O&M Tool and is currently developing the Operation & Maintenance Cost Estimator (OMCE).

ECN's O&M Tool is useful to set-up an initial maintenance strategy, make estimates of the lifetime average O&M costs and support the financial decision making process in the planning phase of an offshore wind farm. This tool is now commonly used in the wind industry. However, the O&M Tool is less suited for usage during the operational phase of the wind farm, where it is more important to monitor the actual O&M effort and to control and optimised the future O&M costs. In order to assist in this process ECN started the development of the O&M Cost Estimator. The total OMCE-approach consists of two main parts: (1) The OMCE-Building Blocks, which are used to analyse operational data from the wind farm under consideration in order to get insight in the performance and health of the wind farm and to derive input data for (2) the OMCE-Calculator, which is a time-domain simulation program with which the expected future O&M costs can be estimated.

In this chapter information was given of the modelling aspects of Operation & Maintenance, the OMCE project and the functionality and capabilities of the OMCE-Calculator and OMCE-Building Blocks.

7. Acknowledgment

This contribution is written as part of the research project D OWES in the context of the development of the "*Operation and Maintenance Cost Estimator (OMCE)*" by ECN. Within this OMCE project a methodology has been set up and subsequently software tools are being developed to estimate and to control future O&M costs of offshore wind farms taking into account operational experience. In this way it can support optimisation of O&M strategies. The OMCE project was funded partly by We@Sea, partly by EFRO, and partly by ECN (EZS).

The development of the specifications for the OMCE was carried out and co-financed by the Bsik programme 'Large-scale Wind Power Generation Offshore' of the consortium We@Sea (www.we-at-sea.org). The development of the event list and the programming of the OMCE-Calculator is carried out within the D OWES (Dutch Offshore Wind Energy Services) project which is financially supported by the European Fund for Regional Developments (EFRO) of the EU (www.dowes.nl).

Nordex AG is thanked for supplying information of the Nordex N80 wind turbines located at the ECN Wind turbine Test site Wieringermeer (EWTW). EWTW supplied maintenance sheets, SCADA data, and PLC data for further processing.

Noordzeewind and SenterNovem are thanked for providing the O&M data and logistic data of the Offshore Wind farm Egmond aan Zee (OWEZ).

8. References

Davidson, J.; *The Reliability of Mechanical Systems*, The Institution of Mechanical Engineers, 1988.

- DOWES; Dutch Offshore Wind Energy Systems (DOWES),
<http://www.dowes.nl/>
- Leersum, B. van; et al; Integrated Offshore Monitoring System; Presented at the DEWEK Conference 2010, Bremen.
- Manwell, J.F.; McGowan, J.G.; Rogers, A.L.; Wind Energy Explained; Theory, Design and Application; University of Massachusetts, Amherst, USA, published by: John Wiley & Sons Ltd, West Sussex, England, 2003
- Obdam, T.S.; Rademakers, L.W.M.M.; Braam, H.; Flight Leader Concept for Wind Farm Loading Counting and Performance Assessment; ECN-M--09-054; Presented at the European Wind Energy Conference 2009, Marseille, France, 16-19 March 2009.
- Obdam, T.S.; Rademakers, L.W.M.M.; Braam, H.; Flight Leader Concept for Wind Farm Load Counting: First offshore implementation; ECN-M--09-114 Augustus 2009; Presented at the OWEMES 2009 Conference, Brindisi, Italy, 21-23 May 2009.
- Obdam, T.S.; Rademakers, L.W.M.M.; Braam, H.; Flight Leader Concept for Wind Farm Load Counting: Offshore evaluation; ECN-M--09-122; Presented at the European Offshore Wind 2009 Conference, Stockholm, Sweden, 14-16 September 2009.
- Obdam, T.S.; Rademakers, L.W.M.M.; Braam, H.; Flight Leader Concept for Wind Farm Load Counting - Final Report; ECN-E--09-068; October 2009.
- Obdam, T.S.; Rademakers, L.W.M.M.; Braam, H.; Flight Leader Concept for Wind Farm Load Counting: Offshore Evaluation; ECN-W--10-008; Published in Wind Engineering (Multi Science Publishing), 2010, Ed.Vol. 34, number 1 / January, p.109-122.
- Pieterman, R.P. van de; Braam, H.; Obdam, T.S.; "Operation and Maintenance Cost Estimator (OMCE) - Estimate future O&M cost for offshore wind farms"; ECN-M--10-089; Presented at the DEWEK Conference 2010, Bremen
- Roddiër, D.; Weinstein, J.; Floating Wind Turbines,
http://memagazine.asme.org/Articles/2010/April/Floating_Wind_Turbines.cfm
- Rademakers, L.W.M.M.; Braam, H , .; Obdam, T.S.; Frohböse, P.; Kruse, N., TOOLS FOR ESTIMATING OPERATION AND MAINTENANCE COSTS OF OFFSHORE WIND FARMS: State of the Art, ECN-M--08-026; Presented at the European Wind Energy Conference 2008, Brussels, Belgium, 31 March 2008-3 April 2008.
- Rademakers, L.W.M.M.; Braam, H.; Obdam, T.S.; Estimating costs of operation & maintenance for offshore wind farms"; ECN-M--08-027; Presented at the European Wind Energy Conference 2008; Brussels
- Rademakers, L.W.M.M.; Braam, H.; Obdam, T.S.; Pieterman, R.P. van de; Operation and maintenance cost estimator (OMCE) to estimate the future O&M costs of offshore wind farms, ECN-M--09-126; Presented at the European Offshore Wind 2009 Conference, Stockholm, Sweden, 14-16 September 2009.
- Rademakers, L.W.M.M.; Braam, H , .; Obdam, T.S.; Pieterman, R.P. van de; Operation and Maintenance Cost Estimator"; ECN-E-09-037, October 2009
- Vose, D.; Risk Analysis - A Quantitative Guide, John Wiley & Sons, Ltd.
- Wiggelinkhuizen, E.J. et al: "CONMOW Final Report"; ECN-E-07-044, July 2007

Wiggelinkhuizen, E.J.; Verbruggen, T.W.; Braam, H.; Rademakers, L.W.M.M.; Xiang, Jianping; Watson, S., Assessment of Condition Monitoring Techniques for Offshore Wind Farms, ECN-W-08-034 juli 2008; Published in Journal of Solar Energy Engineering (ASME), 2008, Ed.Vol. 130 / 03, p.1004-1-1004-9.

Community Wind Power – A Tipping Point Strategy for Driving Socio-Economic Revitalization in Detroit and Southeast Michigan

Daniel Bral, Caisheng Wang and Chih-Ping Yeh
Wayne State University
USA

1. Introduction

Since entering this new century, our global society has faced unprecedented challenges in energy production. It is more urgent than ever to address our ever increasing thirst for energy and the resultant environmental impact caused by the energy production. Today, electricity is one of the most common commodities of energy. The generation of electricity is, consequently, one of the largest global sources of environmentally concerning emissions. According to the U.S. Energy Information Administration (EIA), the overall electric power consumption in the United States has increased from 3302 billion kilowatthours (kWh) in 1997 to 3974 billion kWh in 2008. As a result, more than 2477 million metric tons of CO₂ were emitted in 2008 simply due to electricity generation, which accounts for about 40% of the U.S. total annual CO₂ emissions. In his 2011 address of the State of Union, President Obama mentioned an ambitious goal of achieving 80% of electricity from clean energy sources by 2015 [1]. A majority of states in the U.S. have passed Renewable Portfolio Standards (RPS), which set aggressive goals to achieve given percentages of electricity generated from renewables by particular deadlines [2]. To address the aforementioned challenges and to achieve the clean energy goals, given the ecological and social stagnation that we are experiencing in our urban centers, we will have to come up with innovative, cost effective, community energizing and ecologically friendly complementary additions and alternatives to our traditional power generation methods.

Before introducing what we call the Detroit and Southeastern Michigan Community Wind Power Cooperative Model (henceforth referred to as the “Detroit model”), we shall first describe the traditional community wind farm model upon which it is historically based. We shall also include some of the key refinements and improvements made to the traditional model which subsequently led to the development of the Detroit Model, in order to first familiarize the reader with the foundational concepts of community wind.

Traditionally, community based wind power has involved placing medium to large commercial sized (250 kW-2MW) wind turbines into rural settings to provide electric power for local communities or to be sold externally to make a profit or both. These turbines range in height from 150 to 425 feet and have rotor diameters of between 100 - 300 feet [8].

There have been many forms of ownership throughout the history of community wind, however the most prevalent forms, and for our purposes, most important one’s have

involved either direct community ownership of the wind turbines or land lease rights of ownership of the land upon which the turbines are built.

Most if not all traditional wind farms were developed in rural areas in Europe and North America. They usually consisted of individual farmers or groups of farmers and local community members pooling money together for investment into wind farm initiatives with the intent of providing power for the local community.

This ownership model, which usually took the form of an LLC (Limited Liability Corporation), in North America, eventually evolved to the point where not only was power provided for the local community, but there became a realization that excess power could be sold externally on a “for profit” basis with the revenue from these endeavors going back to the community. Ultimately this in turn grew into the concept of providing all of the power that the wind farm generated to be used in the external marketplace. By selling power this way the local community could derive revenue just like hydro-electric, coal fired and other utility providers do. The difference was that the revenue generated was intended to be shared by the community members as investors in the project as opposed to paying it out to remote stockholders of a corporation or to a private business investor group that had no interest in, or in many cases even knowledge of the community.

Later the concept began to expand further as the local community members allowed neighbors, friends and outside “community interested” investors to join their cooperative in order to attract additional investment dollars for projects. Profits were shared with them as well.

Fundamentally there was a difference in how these cooperatives operated as opposed to traditional companies and corporations. The purpose and intent of the cooperatives was to provide the “local community” with electric power and/or a source for profit which was intended to be shared locally amongst the community members.

There have recently been efforts to extend the “community” benefits of the cooperative model even further between cooperatives, communities and even entire countries (especially in Europe) with what are known as Tariff Feed In laws [8]. Tariff Feed In laws benefit communities as well as electric customers by paying the cooperative a predetermined, overall regionally or nationally averaged, and regulated base rate of revenue, which allows for fair competition between cooperatives regardless of size or affiliation. The payment is provided by the utility and government in partnership. It is a plan that also provides competitive electricity rates to the outside grid, market and ultimately the customer as well.

This is not the only intent of the Tariff Feed In laws, but it is a definite by-product of them and one in which the community benefits. These laws actually level the playing field so that small and large wind power providers benefit in a fair manner. This is accomplished by insuring that large and small producers alike receive appropriate adjustments in their revenue rate depending on economies of scale and the efficiencies that they provide.

The general idea is that the revenue rate paid goes down as efficiencies go up and vice versa relative to an established baseline “fair average rate” based on all of the turbines in a large geographic area in order to keep everyone’s rates equally competitive in the marketplace for all of the providers in that area. It keeps prices competitive based on laws of efficient averages which theoretically should also result in consumer electric rates that are as low as possible for the customers who buy the power.

In order to better understand how the community members benefit from the direct versus leased methods of ownership previously introduced, we now provide the following

simplified example to demonstrate the respective financial benefits of each method to the community. The revenue provided to the community can vary greatly as described in the example depending on many factors, but for the purpose of conveying the basic idea it should suffice.

Under the direct ownership method, a hypothetical 2 MW turbine could theoretically produce gross revenue of \$ 400,000/yr. for its owner if the electricity can be sold for \$0.10/kWh, [8]. From this amount the owner would deduct the aggregated costs of building, operating and decommissioning the turbine over typically a twenty year estimated life. This is usually referred to as operating the turbine at its rated capacity factor which is the proportion of the actual/estimated energy it is capable of generating while taking into account all of its 20 year lifetime amortized cost and performance factors, then comparing this as a proportional ratio to the theoretical amount of energy it is rated to generate for one year. After completing this accounting exercise the turbine could potentially produce a gross profit EBITDA (Earnings Before Interest, Taxes, Depreciation and Amortization), of approximately \$200,000/yr. for the community. Depending on the cost of ownership factors involved in determining the EBITDA the net profit to the owner could range between \$100,000 and \$200,000 yearly assuming that there are no catastrophic financial events and the project is managed in a reasonably responsible financial manner.

If leasing the land is the preferred method, the community can generate royalties, obtain electricity and derive other financial benefits that can total between 0.5-5% (typically \$2,000 to \$20,000 per turbine) depending on size of the turbines, the terms that they negotiate with the power company and other factors defined in the contract. Then there is a “shared ownership” arrangement where the community and the wind turbine power company share ownership and split the expenses and profits between them. This is the ownership model that we prefer and is the base upon which we build the Detroit Model.

The Detroit Model builds and expands upon the above shared ownership definition by adding “community partnership” to the base model. This addition requires that the partners must declare their fiduciary duty to, and be dedicated to the best interests of the community first and foremost. These “community investor / partners” may come from within or outside the community, they may also include the utility, the municipality, corporate investors or any combination there-of. The important idea is that all of the partners have a mutual and fiduciary duty as well as interest in making sure the local community benefits socio-economically and environmentally from the collaboration.

The socio-economic and environmental aspects of the model are crucial additions. The model emphasizes the direct engagement of the community in the development, deployment, execution and in its ongoing commitment to its basic tenet that socio-economic and environmental sustainability benefit the community [28], as a prime directive. It focuses this commitment by insuring that the reservation of jobs, providing education and technical training as well as environmental and community sustainability are incorporated into its fundamental principles [3, 8-10, 13, 14, 16-19, 27, 28].

The socio-economic tool we employ to accomplish the above is known as the 3 E's + 1 (Economic, Socio-Economic, Environmental + Educational) community sustainability concept [5]. The model demonstrates how community wind power can be coupled with the latest socio-economic management tools to provide jobs and education for the community while simultaneously giving them the opportunity to participate directly in the ownership of the business with their chosen partners. It is a model that promotes community self-

determinism and creates a partnership between the community and its utility, municipal, financial, educational, special interest and business institutions.

We now introduce the concept of Community Based Wind Power as a test bed solution to couple electric power generation with social and community development initiatives. As previously stated, the idea is to provide individuals within a community an alternative model for the provision of their electric energy as well as socio-economic needs. It is a popular urban sustainable community development concept that has been implemented successfully many times in Europe [3, 27, 30]. As a great alternate to centralized large wind farms, community based wind power systems for sustainable development of communities has also been the subject of increased interest in the United States recently [3, 8, 16, 27, 30] due to its potential for locating power at its point of application, that is to say close to the community it serves.

It is a model which encompasses all of the steps required to initiate, plan and manage the processes required for developing a community cooperative based wind power system and business partnership model for application in the Southeastern region of Michigan.

A unique feature of the Detroit Model is that it takes a community cooperative business approach which gives individuals within a local community the opportunity to take a direct ownership position in any wind energy venture (optionally along with other investors and/or the local utility) that may benefit their community. This type of business model provides the community with a direct way to benefit economically as business owners from the venture. At the same time it provides the community with employment opportunities as well as gives them a direct say in how their electric rates should be calculated as seen from a rate payer/cooperative owner perspective. The goal of course is to potentially lower their electric energy bills through effective self-management of costs. It is a concept that truly supports community self-sustainability in the best democratic sense.

For sustainable community development programs to be successful, it is crucial that the various constituencies within the community be tightly coupled via effective collaboration between each of their respective social networks within the community. The questions are then, who are these partners and how do we develop effective collaboration between them? In order to answer this question lets first start with a discussion of the history of community collaborative efforts in order to put our current effort to build the Detroit Model into context.

2. Literature review of community cooperative models

There has been a long and arduous history of attempted collaboration between government, community and business that dates back in post modern history to just after the Civil War. Examples exist of early successes and failures that are worth note. Chicago during the 1870's and 80's had extreme problems with filthy smoke and soot from coal used to power homes, steel plants, trains and many other endeavors as well as with stench from the numerous slaughter houses in the city [16]. This was one of the first opportunities for the "Business Community" to rise to the occasion and try to put reforms into place to mediate and control the pollution which they did by organizing the Chicago Citizens Association. They were successful in passing city ordinances to limit smoke from such businesses by passing key smoke ordinances in 1881. There were other successes as well, showing that business led consortiums could self-regulate to a limited degree.

On the other hand, there have been many notable failures and even deceptions that occurred when business colluded with government to manipulate the development and/or

application of regulatory laws put in place. This behavior provided numerous grounds for the community to not trust business to “go it alone” when developing ordinances and regulations. More recently many of the same negative lessons were more recently re-learned in the 1970’s through the 90’s when environmentalists clashed with business and industry over oil, forests and other natural resources [16]. People in the cities also felt that they were being disenfranchised in terms of having a voice in their communities economic well being and development as all the direction seemed to come out of Washington and to a lesser extent their local government. Little direct individual community involvement was tolerated nor were they invited to participate in the decisions that directly affected them.

In recognition of the above history as well as understanding that people from the community and their collaborative partners constitute the first of four key pillars that are necessary for successful community planning a mutual understanding must first be established between each partner’s perspectives, agendas, intentions, goals and objectives for their shared vision of and for the community. The question now becomes, who are these partners and how do we develop effective collaboration between them in order to develop successful sustainable community development programs.

To start, all of the partner members within the community must begin by taking a “team approach” to be successful at building their communities. Thus, community outreach has become a key factor in this arena. We find ourselves today in a place that includes environmentalism, community sustainability, recognition of the value of human capital and corporate stewardship as part of our community consciousness. This level of working together is opportunistic to the point where we have a synergistic possibility of uniting previously embattled and opposing forces to a degree previously not thought possible. Recognizing this fact may allow us to accomplish advances on a community development level that just a few short years ago would not have been thought possible.

It is important to note that the above principles mesh to support the community sustainability model based on the 3E’s (Economic, Socio-Economic, Ecologic) + 1 (Educational). In addition, there are 6 formally structured community sustainability models that particularly support the above principles: These include: The ORTEE (Ontario Round Table on Environment & Economy) Model, Minnesota Local Model, Netherland Model, Natural Step Model, Houston Model and the CERES (Coalition for Environmentally Responsible Economies) Model have been proposed and used as guiding principles for building sustainable communities [5]. The first three models are community level government focused while the last three models are business oriented. The details of the models are given in the rest of this section. Of these we shall select the best attributes of each to incorporate into the Detroit Model. But first let us review each of the older models before submitting our hybridized model for presentation.

The ORTEE Model defines 12 guidelines for “local” communities to achieve consensus, which is a locally focused model [5]:

1. Growth limits based on carrying capacity
2. Value cultural diversity
3. Respect for other life forms & biodiversity
4. Shared values with others in community (education)
5. Ecological thinking embedded in governmental decisions
6. Make balanced fair and informed decisions
7. Make best use of local efforts and resources

8. Use renewable resources
9. Minimize harm to environment
10. Use materials in continuous cycles
11. Not compromise other communities sustainability
12. Not compromise future generations sustainability

The Minnesota Model defines 5 guidelines for “local” communities to achieve consensus at a *regional* level [5]:

1. Global Interdependence - Consists of 4 factors - Economic prosperity, ecosystem health, liberty and justice.
2. Stewardship - Caretakers of our environment.
3. Conservation
4. Indicators - Clear Goals and Measurable Indicators.
5. Shared Responsibility - All take responsibility for sustaining the environment and economy.

The Netherland Model defines 11 guidelines for giving value and connecting local and regional sustainability issues to the national agenda [5].

1. Intergenerational equity
2. Precautionary principle - Not allow decisions to compromise environment.
3. Standstill principle - At a minimum environmental conditions within the community shall not be allowed to further deteriorate.
4. Abatement at the source
5. Polluter pays principle
6. Use best applicable technology
7. Prevent all unnecessary waste
8. Isolate, manage and control wastes that cannot be processed
9. Internalization - Environmental considerations are to be integrated into the actions of all responsible parties
10. Integrated lifecycle management
11. Environmental space - Recognize the limits of each resource that people can consume.

The three models previously discussed are considered community through national level government focused models. The following three are business focused. The key concepts of local community emphasis and partnership with business from these models are coupled in the Detroit Model.

The Natural Step Model is scientifically based on 4 “system conditions” for sustainability. This model combines business management and science to state rules for sustainability [5]:

1. In order for a society to be sustainable, nature’s functions and diversity are not systematically subject to increasing concentrations of substances extracted from the earth’s crust.
2. In order for a society to be sustainable, nature’s functions and diversity are not systematically subject to increasing concentrations of substances produced by society.
3. In order for a society to be sustainable, nature’s functions and diversity are not systematically impoverished by physical displacement, over-harvesting or other forms of ecosystem manipulation.
4. In a sustainable society resources are used fairly and efficiently in order to meet basic human needs globally.

The Houston Model takes the Natural Step model to an additional level by combining the business and science perspectives with the linkage of the labor and environmental movements. It asks for corporate, labor and environmental accountability. In essence it states in its charter that a healthy economy and environment for a sustainable community must require a “dynamic alliance” between labor, management, and environment advocates and sectors and quite importantly the agents from each of these sectors are required to sign the principle document and agree to work together in a spirit of cooperative partnership [5]. The CERES Model is less strident and demanding in its accountability requirements than the Houston Model and also less formal in its legal compliance requirements than the Houston Model in that it is voluntary. It does however focus on cooperative collaboration between the aforementioned groups as outlined in the Houston Model and also affirms support of protection of the biosphere, sustainability, reduction and disposal of wastes, energy conservation, risk reduction, dedication to safe products and services, environmental restoration, keeping the public informed, requires management commitment and relies on formal audits and reports.

3. Model template

The Detroit Model is based on the fundamental premises that community collaboration and direct democratic involvement is essential for the model to function properly. There are four key pillars and a community collaborative foundation that supports the scalable model in order to make it effective. The four pillars are:

1. Neighborhood/Municipal/Business/Utility/Financial/Educational Collaborative partnership model to support community sustainability.
2. Job creation model to support the community.
3. Educational model to support the community.
4. Mutually beneficial financial model for all partners.

The base foundation must be established first before the 4 pillars can be implemented. This foundation is the recognition by all of the stakeholders that effective communication must exist between them before any meaningful group trust, interaction and partnership can occur. It is of utmost importance to first recognize that it is the people from the community and the businesses within it that constitute one of the pillars that is necessary to have success when a team is charged with developing a community sustainability plan. It is crucial to recognize early on that the various constituencies within the community be tightly coupled via effective collaboration between each of their respective social networks within the community. The question is then, who are these partners and how do we develop effective collaboration between them in order to develop successful sustainable community development programs. To answer this question it is necessary to first understand that communities have recently begun to realize that it will take a “team approach” to be successful at building their communities. Outreach has become a key factor in this arena.

It is also important to recognize that we are currently at a tipping point in Southeast Michigan’s history due to economic, topologic and demographic shifts as well as social, educational and corporate shifts that have all recently converged to allow us a unique opportunity for rethinking what our future might be if we work together to redefine it. The opportunity to take advantage of this convergence indicates that if effective outreach is made between the community’s members and their municipal, educational, and business community partners in a collaborative “action based” way it will allow us to redefine the

foundation of what our socio-economic infrastructure is based upon [6, 22-24, 26, 27]. We may then be able to achieve socio-economic, community and environmental gains previously thought unattainable. Once the foundation is established, then each of the three remaining key pillars can be more effectively addressed.

It is crucial to recognize early on that the various constituencies within the community be tightly coupled via effective collaboration between each of their respective social networks within the community. The question remains then, who are these partners and how do we develop effective collaboration between them in order to develop successful sustainable community development programs. In order to answer this question we need to first understand how to establish the group dynamics necessary to build a strong foundation for each of the four pillars. To accomplish this we provide the following group dynamic insights, experiences and guidelines as being an essential pre-cursor to any effective group collaborative effort.

Also note that the socio-economic aspects of the model are intentionally designed to be extensible [9, 16, 17, 28]. Thus, before we explore the community wind power concept further the reader should note that the model is intended to be extended to other sustainable as well as regular community development efforts. These community business development efforts include but are not limited to: Alternative energy initiatives such as solar, geothermal and landfill gas, as well as development of regular businesses including retail establishments such as pizza shops, drug stores, and boutiques, and on to commercial ventures such as city parking lots and structures, city farming and many other potential cooperative community ventures.

The key to the overall concept is that it is based on “shared ownership/responsibility” within the “local” community [9, 10]. It includes all of the various community partners working in concert with the local municipality and educational institutions to effect positive and mutually beneficial socio-economic results for all of the partners sharing the community.

Before the group can work effectively together in order to achieve their goals and objectives we must first address the group dynamics with specific methodologies that can be used to influence and insure their effective interaction as a team.

The following discussion describes the internal and external influences that affect the group dynamic and addresses the methodologies that can be used to positively influence it. The process breaks down to understanding the following key concepts [11, 17]:

1. The model employs “actors” who are defined as interested or disinterested parties that are affected or involved in the collaborative process involved in building the community project.
2. There are realities, individual experiences and expectations that each member of the group has brought to the table in regard to how they perceive the project within the context of how it affects them and their community. Each perspective must be carefully understood by the group before any effective collaboration can begin. External real world factors and processes impact how each person sees the reality of their community’s situation. Internal psychological factors influence how they internalize and perceive the meaning of those factors. The idea is to get everyone as close to a common understanding of the situation as possible before beginning to discuss how to improve it.
3. The process involves first teaching the group why “instruments” (formal documented processes, procedures, laws and ordinances and project plans) are necessary for defining and attaining the key objectives of the group.

4. The implementation phase accounts for what is needed in terms of cost and effort to implement the instruments in a practical manner to achieve the objectives of the group.
5. The group must be taught that there needs to be a measure of effectiveness of the information produced in order to account for their impact on the project.

There are two major instrument categories for understanding, managing and directing community behavior: 1) Classic Instruments; and 2) New Environmental Policy Instruments [17]. These two categories equally and categorically break down into the following 5 major instrument “types” as follows:

1. Command and control instruments which are legal and regulatory in nature in order to influence behavior.
2. Economic instruments which are monetary and supply and demand based in nature and which rely on such “economic” laws and theory to influence behavior.
3. Service and Infrastructure instruments attempt to influence behavior by physically manipulating the environment to change or motivate behavioral changes.
4. Collaborative Agreements which seek to influence behavior by using either legally or non-legally binding commitments that seek to engage private and governmental entities in mutually beneficial collaboration in order to achieve behavioral change.
5. Communication and Diffusion Instruments which seek to initiate behavioral change by force of marketing and other public information dissemination techniques.

In addition when using the traditional approach in applying these instruments it is necessary to reassess the usefulness of using traditional policy instruments that are solely based on making decisions by using “public” community/government based analysis instruments only. We replace that model with a new one that also incorporates and couples them to the use of “private” business based instruments that together provide a much more comprehensive, cohesive and coordinated approach for doing the analysis. Many of these new private instruments address how the business world should interact with collaborative groups in the public sphere and government as well as how to become leaders and good partners with communities and ecological interest groups. In addition these instruments add technical and business process experience to the partnership. As an example, Six Sigma, Lean and ISO 14000 methodologies are now being added to the discussion making the resultant combined solutions much more robust and effective [20].

Next, our model proposes using the simplified model of human action as discussed by Ruth Kaufmann-Hayoz and Heinz Gutscher in their book *Changing Things-Moving People* [17] for explaining how people perceive information, react to it and then interact within the group based on these perceptions. The readers are referred to the book for more details about the Human Action Model and Group Dynamic Management.

We believe and emphasize that it is imperative that any community group first, engage in exercising these concepts before tackling the actual community wind project development. As previously stated, without setting the foundational stage for establishing the proper group dynamic, most group efforts of this complexity fail. It is also worth noting that group dynamics vary based on many factors such as their homogenous localized culture such as in small farming communities versus large diverse urban areas or because they are in areas that may or may not have large population densities or a complex non-homogeneous corporate/municipal/community/utility/special interest group mix where stakeholder agendas may conflict to a greater or lesser degree due to the constituency or interests that they represent. Basically group dynamics can be (but are not always) easier to accommodate in simpler more homogeneous circumstances when everyone knows everyone else within

the community and/or deals with one another on a regular basis due to the locality of their geographic circumstances and closely knit social networks. Essentially group effectiveness largely depends on how well the stakeholders know one another from a social networking perspective. It is this level of intimacy that the Detroit Model seeks to establish between the partners by first addressing the group member and constituency backgrounds, learned behaviors and expectations and assessing their dynamic interactions, abilities and capabilities in order to show them how to attain and instill within the group the levels trust, accountability and sense of common cause necessary for their community project to be a success.

There is a correlation between how complex the mix of social, economic and cultural factors is and how complex the management of the group dynamic may be within the group. These factors are addressed in the model by teaching the group how to refocus and manage their dynamic interactions, differences and energies in order to become a tightly knit and unified collaborative that has a new common sense of purpose and aim toward optimizing the community's potential for success instead of wasting it on group infighting and dissonance.

4. Project management and technical aspects of the combined model

There are several key and important project management steps that must be understood before undertaking the development of a wind power community cooperative. The most important of these is the recognition of the fact that the technical and project management goals cannot be achieved without putting "first things first", and that means attending to the group dynamics of the model first and foremost.

From a technical level we must consider the trade-offs required for using a central, distributed, localized or hybrid energy model for urban communities. For the type of urban design we are addressing i.e. urban community wind, a localized distributive model fits best. There are several reasons for this choice. First the currently favored and generalized model of bringing power into the community from the grid involves significant infrastructure costs (between \$500,000 and \$1,000,000 per mile), operational and maintenance issues and not least also involves a lack of convenient access or local control over its management and operation. These concerns take the issue of where to locate the power generation equipment out of the community's sphere of influence to a large degree and certainly do not require their involvement in its operation. It is "out of sight and out of mind". A legitimate argument can be made that this is a good thing and it is the traditional way that we have managed the power flow to our neighborhoods up to now. However, in the 21st century, this traditional approach may not make the most economic, environmental, technical or community sustainable sense in terms of how it impacts localized urban communities. These communities are distributed throughout a given geographic region and could benefit from the lower emissions given off of the power plants (i.e. wind turbines), the improvement in system reliability as the distributed electrical system model being superior to the centralized model currently used would have much more backup capacity and capability if power interruptions were to occur and the communities themselves would benefit much more from local jobs and financial offshoots from the projects put into their neighborhoods. In addition, instead of "out of sight, out of mind", the Detroit Model is designed to bring more "in sight and in-mind" awareness to the community of what the benefits would be for having an electric power company in their neighborhood.

Like any other business case, be it building a remote power plant or siting and installing a small wind turbine or solar array, it is important to remember that each case requires a technical, economic and social implication study before any of them can be either eliminated from contention or found to be a superior solution relative to other options. In the current business environment, these decisions are largely made solely by bigger businesses, utilities and government and not by local communities which given the current system makes significant sense, however we are now at a point where other options are available and at a point where society is looking for the best solutions it can identify for these new paradigms that are evolving.

In a sustainable community we are attempting to “empower” the community to have much greater say, control and awareness in the way energy is produced and consumed in order to provide them with an economic engine that can help support the community [28].

By employing a local owner/operator distributive hybrid model in partnership with the utility, the community has more control over costs as well as the benefits made available through education, local jobs and distributed profits from the endeavor to the participating community members. Reliability is also an issue and because local generation backed up by the grid and directly supported by the onsite workers in the community, we propose that the reliability would have the opportunity to improve because of the models distributed yet localized nature, if managed correctly in partnership with the utility.

One risk is that different communities would not have the same baseline electric cooperative building standards. For this contingency we propose that the state and federal government establish minimum standards through their electrical standard regulatory agencies such as the DOE (Department of Energy), FERC (Federal Energy Resource Commission), MISO (Midwest Independent Transmission System Operator) and on the state level the MPSC (Michigan Public Service Commission) for urban community wind just as they always have for the current traditional power generation and distribution model.

In addition not all technical choices make sense to implement on a local level based on a myriad of factors such as wind speed, amount of sunlight, noise, vibration, aesthetics, available land space, proximity to people and other factors. However, with proper community, municipal, business and utility involvement many favorable locations exist even in high density population areas. It is just that there has been very little actual research or attention paid to properly analyzing the business or technical cases for putting these systems in such areas. There has of course been a tremendous amount of discussion and opinion regarding the topic, but as of yet little empirical data has been actually collected in order to properly address the subject.

These projects as well as the Detroit and Southeastern Michigan model that we present here follow similar project path planning methodologies. It is important to emphasize the use of the concept of “process building” as central to the community building concept. Every task and project outcome is to be assigned and treated as a “process”. This is so that each process can be documented and optimized as the project progresses. In addition it is also important to make sure that the project is based on setting key milestones, goals and follows an “action oriented and accountable” methodology. In short good project management, communication and team building skills are a prerequisite for successful project planning and implementation. All of the above project planning and execution functions are embodied in the principles of Six Sigma, Lean and Professional Project Management. We propose and require that each of these methodologies be incorporated into the Detroit Model.

Goals and key project decisions are made up front and must include attention to “process” details such as how will the collaborative team be assembled and managed, how will the decision making processes be implemented, what process is to be used to choose 3rd party stakeholders, what criteria shall be used to determine investor participation, how is the grid interconnect process to be handled, how shall the site selection and permitting process be conducted, who and how will the administrative side of the business be organized, how will the procurement process work, how will the legal aspects of the project be managed, who and how will the political issues be managed between the community and municipality. These and many other processes need to be managed in a parallel fashion as the project progresses. A brief overview follows of some of the more important details that should be paid attention to.

There are several excellent community alternative energy projects and planning models which provide excellent guidance for building strong collaborative efforts for implementing wind power. Two examples are the Windustry Community Wind Toolbox project [3] and the LACCD (Los Angeles Community College District) project for community sustainability [16].

A project management plan is crucial for effective communication of the projects status to all of the stake-holders. A master plan is required for the Detroit Model and should be developed to include all of the necessary steps listed below [3, 5, 9, 20].

- Provide a project master summary document that outlines the goals and vision of the project.
- Identify the community members involved in the project including the business, community, academic and municipal partners and provide them with a communication and relations plan specific to each.
- Provide a “Group Dynamic” management plan and include upfront training to address group dynamics and project management skills.
- Develop a business structure and plan appropriate for the community. i.e. LLC, Corp., Sub Chapter S, etc.
- Develop an environmental risk, action and improvement plan.
- Develop a project risk plan.
- Develop a legal issues planning document.
- Develop a community and utility business partner plan.
- Develop a project management plan, flow and Gantt charts to manage construction, logistic, supplier schedules and other important project timelines and functions.
- Develop a community jobs, education and socio-economic development plan.
- Provide a community and business partner analysis plan showing the overall benefits to the community. Include all relevant economic, social and environmental benefits and potential detriments.
- Provide a wind and resource assessment plan.
- Provide an economic, social and demographic analysis plan.
- Provide a finance model and plan for the project.
- Provide a community revenue sharing plan.
- Provide an electric rate adjustment management plan.
- Provide an electric rate estimate projection plan.
- Manage the Power Purchase Agreement (PPA).
- Provide guideline for turbine selection and purchase.

- Provide a construction plan
- Provide a community architectural plan
- Provide a community sustainability plan
- Provide a long term power development plan
- Provide a grid interconnection plan.
- Provide a plan to address all legal, tax and insurance issues.
- Develop a plan for identifying financing resources and investors.
- Develop a financing plan for the purchase of the system
- Develop an operations, financial management and ongoing maintenance plan.
- Provide an end of life plan.

It is also important to carry out a risk management analysis of the cooperative. It is imperative that all of the various risk factors be identified and continually monitored throughout the project. Key early risk factors include determining the suitability of the site for a wind project, i.e. is there community, local business, special interest, banking and municipal support for the project. Is there a convenient grid interconnect available for the system, does a substation need to be built, is the wind speed and quality of sufficient magnitude to justify a system, do the zoning laws and or federal restrictions prohibit a wind farm from being built, is the community favorable to having a system put in their backyard, are the financial institutions favorable to the economic viability of the venture. These factors are important and must be addressed before committing the extreme amount of time, effort, financial risk and community good will to a project that may be doomed before it is even begun. So doing the preplanning and homework are critical to the success of the project right from the start [22].

Next, the wind site and resource assessment plan is critical in determining the success of the project and should be conducted upfront before any substantial investment is made in the project [3, 19, 31]. It includes assessment of wind speeds, site potential and identifies any barriers that would preclude building the system. The resource assessment should take into account the electric grid resource locally available. It should also account for any legal issues or protected environmental issues that would preclude building the project.

The economic assessment should account for all of the economic benefits and detriments that would be expected for the community. Particular attention should be placed on quantifying and explaining the potential benefits and detriments (emphasizing the potential detriments), in a very clear and concise manner so that everyone in the community is made aware of and can understand all of the personal as well as public risks they are taking on as an individual as well as a community. The public disclosure of these risks should include ongoing and regularly scheduled discussions of the projects financial, economic, safety, liability, environmental, legal, social and community disruption risks that the community may encounter. Initial and continuing meetings to keep the community informed on a personal as well as community level is imperative.

In addition close attention should be paid to the social and demographic aspects of the site. The community will have this installation in their backyard for 20 to 30 years and all of the social, economic, architectural, security and safety issues and impacts that it will have on the community need to be studied, documented, publically addressed and presented to the members of that community.

Financing options for community based wind power projects are first and foremost restricted to community ownership in our model [29, 30]. This is because the intent of the

model is to provide the members of the community with all of the financial advantages of shared business ownership between them and their community business partners, i.e. the utility, local businesses and possibly the municipality. It is a model that works quite well in rural areas already in the form of rural privately held community cooperative wind farms, electric cooperatives, public and private community/municipal wind and electric cooperatives, and other forms of mutually beneficial cooperatives.

The main idea of all types of cooperatives of this nature is that the “members”: the community members and special interest groups, community business partners, utility partner or municipal partner, share in the ownership and also enjoy receiving income and in many cases more competitive electric rates than would normally be provided by outside electric power providers. Much of this has to do with the idea that in a cooperative it is the members or a board of directors that the members elect who decide how the company will be run, how the rates will be set and how any profits will be distributed.

With the community wind power cooperative model we propose going even further [27, 29]. The members shall not only share in all of the above mentioned benefits of cooperative ownership, but will also have more direct say and involvement in the management and governance of the business. Those choosing to be non-active participants will still have voting and ownership rights. All members within the designated area of the community will be eligible for education and training provided to support the company. Those desiring to actively participate in the business will have the opportunity to do so based on paid or voluntary positions being available.

Owners will benefit financially from stock ownership in the cooperative as well as from their membership in their cooperative banking/credit union used to finance the project (to be discussed in a later section). People just outside the geographic area of the cooperative shall also have an opportunity for participating in the profitability of the business via reduced prorated levels of profit based on how close they live to its boundaries. They will not however be entitled to the direct community benefits of jobs, education, training or participative ownership. This is done so that neighboring communities are financially remunerated for allowing the wind systems to be built in proximity to their neighborhoods. It is a model that has been successfully used in Europe.

Because the model involves community ownership it necessarily excludes some of the standard options that would normally be pursued. Specifically, “exclusive” outside investor ownership is not allowed, nor is “exclusive” utility ownership. These exclusions vastly change- the business ownership landscape from that of the traditional utility ownership model. Now the local community must find a way to obtain financing. This is solved by using the partnering models as mentioned earlier. The challenge then becomes whether or not the venture can be made financially attractive enough for either the community alone or the community in partnership with the investor and utility together as one entity [8, 29].

The model provides financial options and resources to accomplish this as can be seen below [3,8,9,16,21,30,33]:

1. Utility financing/partnership
2. Outside investor partner financing/partnership
3. Sustainable Community “Common Good Bank” bank financing/partnership [21]
4. External public/private stockholder financing [8]
5. Municipal financing/partnership
6. Bank financing

7. Local credit union financing
8. Federal/State Government financing/grants
9. Industrial and commercial parks

Each of the above finance partner options has its pros and cons, those that we will focus on and incorporate into the model shall have the “partnership” element attached. The others, credit union and bank financing as well as self financing through federal grants follow a more traditional path of finance and are mentioned only to display, compare and contrast the other options that may be available.

We first consider the Utility financing/partnership concept. This potential partner has the benefits of possessing available land, financial resources, a moderate willingness to partner with the “right” partner, the know-how for understanding the financial picture required to build a community wind farm, the expertise and trained personnel to service/operate/maintain the wind farm, the ability to offer the community a long term loan to be able to finance the community’s half of the venture, and are in need of renewable energy sources to fulfill their Renewable Portfolio Standard federal gov’t requirements. They are eager to find capital investment programs that provide PTC (Production Tax Credits) and ITC (Investment Tax Credits) such as wind power projects offer to be able to offset their tax liability by up to 30% and are interested in any state and/or local government incentives that might be available to them [4,34].

All of the above factors combined result in lower costs for the utility should they maintain ownership of the system. These cost savings can be shared or passed on wholly or in part to the community/utility partnership if it makes economic sense to the utility to structure the endeavor in such a manner.

Another option is for the utility to provide the community partnership a lease arrangement. This allows the payments to be more predictable over a period of years because all costs are established up front for the duration of the lease versus being variable if the system were to be bought outright. The utility is agreeable to this arrangement in some cases because it is able to take advantage of the tax credits, incentives and depreciation because they own the assets.

There is also the option of using a buy-back arrangement where-by the utility is able to “own” the wind farm for a period of years (usually for at least the accelerated depreciation period allowed for wind of 5 years), during which time they take advantage of the tax credits, incentives and accelerated depreciation available to them. The community partnership pays the utility only the cost of the electricity sold to them, its initial capital acquisition costs and ongoing maintenance costs on a cents/kWh basis which is often less if the community owned the turbines outright. At the community’s option after a minimum holding period that usually corresponds with the 5 year depreciation period (during which the system had in most cases been paid off by the utility), the community takes full ownership, the only remaining costs are the ongoing operation and maintenance fees. It is only these fees that must be paid on a cents/kWh basis for the monthly bills to the community. Typically these bills are substantially less than what they were prior to the utility paying off the system, or even for the scenario where the community has outright ownership from the beginning.

On the other side, many utilities prefer to provide the community with power as they historically have and prefer to retain profits from 100% of the community as opposed to sharing 50/50 with them. Utilities also may not be inclined to loan the community funds for the community’s half of the venture. This could be for many reasons not the least of which is

that they may not see themselves in the lending business or are not willing to accept the risk. In addition, note, that utilities are looking for a minimum 15-20% ROI (Return on Investment), a 17-23 IRR (Internal Rate of Return) on their investments. All of this leads up to the fact that as you attempt to work with a utility as a business partner, it will require substantial work above and beyond that required to obtain financing from traditional lending sources. The reasons for this are clear from the previous discussion, however considering what the utility brings to the table in regard to the partnership may well be worth the effort.

Outside investor/partner financing in our model requires partnering with investors outside the community. These types of investors come in many forms such as individual investors, investment clubs, investment companies, energy fund companies, angel investors, investment partnerships and a myriad of other groups. However, they all have a couple of things in common. (1) All outside investors want and need to make money from what they perceive as being a solid investment in wind power projects. (2) Most people want a large share of ownership and profits and three many prefer to take a lead role in their investment, keeping their own company's best interests above that of the community partnership. This is not to say that the other partnership models are significantly different, but here it is a matter of degree. Expect to negotiate at the most direct and intense levels with this investment group. Their fiduciary responsibility is to their own company and the community wind partnership is an investment for them that they need to maximize to their greatest advantage. However, if negotiations are managed carefully and in the best interest of the cooperative, this is the most likely group that will give the partnership access to capital funding.

The purpose of forming a partnership with an outside investor is to gain access to funding, therefore in keeping with our models principles insure, that in no case voting rights, management, and distribution of profits be inequitably distributed to them. It is important that the partnership be fair and equitable for all parties. It is especially important that the decision making and voting rights of the community hold balance in a democratic way against the voting rights of the outside investor. This may mean that the deal be struck such that the investor be given their 50% or less share of the profits, but hold only one vote amongst the other community members individual votes. This requires difficult negotiations up front when the partnership is being formed. It is equally important that the investor not be given management authority beyond that which is balanced by management authority on behalf of the community. Essentially then, it is access to funding that is the key to this working relationship. Beyond that, unlike the utility partner model, alliances must still be sought outside the partnership in order to aggregate land, develop expertise and deal with the power utility for access to their grid.

It is of equal importance that the agreement between parties explicitly states that the intent of the project is not only to produce profit for both parties, but also to provide access to business ownership for the community members as partners of the cooperative. The partner must be agreeable to hiring to the maximum extent possible all manner of employees from the local community for the construction, supply of material, management and ongoing operations, maintenance and service of the community utility for the duration of its life. They must also be amenable to the collaborative providing educational opportunities via the partnership for the local middle schools, high schools, community colleges and universities in support of educational programs that support their employees and the community's educational needs in order to support the project.

Having stated the above, it is still advantageous to partner with outside investors if they will agree to become a true partner and support the community initiative's goals and objective unflinchingly. It is in this manner that jobs, investment and profits can still be kept within the community and the partnership still produce exceptional results for both parties.

All of this is accomplished under the direction of the banks chartered collaborative members. It is the members who become shareholders by becoming depositors just as in credit union cooperatives. The members must adopt the by-laws of the chartered bank which gives each member one vote which is valued the same for each member. Each member uses their vote to decide how to organize, operate and determine how loans shall be lent out for projects in the community. It is the community member stockholders who run and operate the bank, with local community members providing the workforce. All interest and profit derived from the income from the specific loans for the wind project are returned to the stockholder members. This banking business ownership concept is in exact harmony with the concept we are presenting for the operation and management of the community wind power cooperative [3, 16, 21].

The public/private stockholder/partner financing option involves soliciting funds through public and or private stock offerings. It is an excellent way to raise capital financing. It usually involves seeking financing to raise enough money to put a down payment on a loan. Usually this involves 20-50 % down. Then loan carrier then finances the remainder of the loan. However, in some cases higher levels of stockholder funding does occur. The main difference with this type of financing is that the "stockholders" do not have day to day management involvement in the project and only hold the shares as an investment just as they would any other stock or mutual fund investment. There are however tight restrictions to offering this type of financing arrangement. Now you are making a public/private stock offering which requires a specialized lawyer that is familiar with federal stock exchange laws. These specialists are necessary because they are familiar with how to structure a deal of this nature so that it meets the federal and state legal requirements for offering stock ownership in the company. Having said the above, this is a good way to raise capital in order to qualify for a loan for any outstanding balance while not having to take on an active partner in the business. Municipal financing and partnership is considered an adjunct to each of the other forms of community cooperative partnership. It takes its form by making the municipality a partner early in the formation of the cooperative effort. The benefits of partnering with the municipality are that they bring potential locations for siting and development of the wind farms to the table by giving the community access to public properties for minimal or no cost in many cases. The main goal of the municipality is to put their underused properties to their "highest and best use" as well as add them to their tax roles. In many cases school properties having adequate open space can be added to the tax roles as well as provide real life science laboratories for educational and trades training purposes. Coupled with the potential for federal and state grant funding to supplement and support the public education and community outreach efforts they can be a powerful incentive and symbol in the community for promoting and teaching the public about alternative energy, business and technology as well as an avenue for providing jobs.

5. Economic, socio-economic, ecological & educational aspects of the model

In regard to the socio-economic aspects of the model, there are currently quite a few (several hundred in the world) real world examples of entire communities that have become sustainably energy independent [16, 28].

A key goal in achieving that independence is to keep income from the venture within the community to the greatest extent possible for the direct benefit of its members. The traditional investor/owner/operator model is one that largely is owned by outside investors, run by outside management, operated and maintained by employees from outside of the community and dictates that profits be distributed not to the community but back to the outside investors in return for their involvement. This model rationalizes that the outside investors are relatively heavily capitalized, have the political and influential connections to be able to effectively take the risk and lend money to these types of ventures. As such the model also rationalizes that because of these factors that the outside investors deserve 100% of the profit returned from the investment in order to compensate them fairly for the risk that they take.

The community model re-balances this relationship by engaging both groups in a mutual partnership arrangement. The aim of such an arrangement is to provide economic and socio-economic advantage to both the community and its outside investor, be it the utility, municipality, business partner, bank or outside investor such that all parties derive fair and equitable benefit. It is a model that recognizes the risk taken by the outside investors and compensates them fairly for their investment while at the same time adding a new dimension to the "recognition of risk" factor taken by the community as well.

Here-to-fore there has not been much emphasis on the "risk factor" that is being undertaken by the community. In fact it is the community where the endeavor is being built, will operate for 20 or 30 years, impacts them by either providing or not providing direct company jobs, or impacts them by upsetting them to see the jobs go outside the community, it impacts commerce within the community, i.e. trucking, maintenance services, package delivery, and many other commercial offshoots, it directly affects the design and aesthetics of the community, it impacts the educational opportunities provided to the community, affects the return of profits and corporate benefits to the community, influences how community members think of themselves no longer as passive bystanders, but now business owners and financial partners with a say in determining a vision for the future of their community.

It also influences how the community members think of the possibilities for their own and their family's futures in regard to business ownership, jobs and careers. It also empowers them to recognize that it is their community's partnership with the municipality that has the potential to open up opportunity to provide land and resources to be able to share in determining how these resources might be best shared with the community to serve to benefit it and its partners to the maximum extent possible. It is both the community and their chosen partner's that are equally impacted by the decision to build a community wind power system in the neighborhood. It is the purpose of this model to demonstrate that with some new and out-of-the-box thinking that there can be a much more effective way to maximize the financial as well as societal benefits beyond those currently enjoyed by both partners being separate as is in the model.

In order to accomplish the objectives stated above, there are several key lessons learned that are significant enough to mention here before continuing in order that best practices can be appreciated and more so applied to future projects. First and foremost, the better designed community sustainability collaboration schemes have in common the fact that they put the interests of the community first. It is this crucial fact that seems to elude many communities that attempt to employ a sustainability effort in their own backyard, and fail. The better run collaboration schemes go to every length to plan, collaborate and enjoin not only people

within their small sphere of influence or social network but also include all of the key actors and outside influences in their plan. Many of the very best go so far as to reach out to their traditional opposition and try to get them to join the group, not to convert them but to get their balanced input so that should the community plan be developed it will have the very best pro and con perspectives and observations incorporated into their key documents. These groups actually “reach out” to other community members and request not only their opinions but also their active participation in the development of the community.

As discussed earlier, it is important to pay particularly close attention to the dynamic we call collaboration. It can and does determine whether projects succeed or fail regardless of the technical merits and planning that may have gone into the project.

Next we consider the Community partnership aspect of the model. Our partner model relies on the concept of the community members taking action and organizing their combined community strengths including their, intellectual and financial capital, political will, business acumen, educational and technical expertise for a common vision and cause that benefits all of its members equally. Those members include the community and activist organizations at large, the utility, municipal, educational, financial, legal, and business owners that have a stake in the community and have its best interests first and foremost in their hearts [4, 9, 15, 28, 30].

The model we propose is to develop legal partnerships between the project partners in the community that will come together for the specific purpose of developing, operating and maintaining wind power and its associated infrastructure for the benefit of the community. The partnership and resultant benefits that we propose are as follows:

- All community members and partners participate in the development board to insure all opinions are accounted for and addressed properly.
- Employ a Cooperative legal business structure that provides financial opportunities for its community members. Consider either for profit or non-profit model. Either way the financial benefits go directly to the community members and their business partners.
- Lower electric bills.
- Puts the community and its partners in charge of business decisions giving them a sense of control over their utility spending and allowing them to think like a business thus keeping expenses in check.
- The cornerstone community partnership in the model is that of the community and local utility in which a 50/50 business partnership is created. Revenue is shared equally.
- Excess revenue generated by the turbines is returned to the community to lower their electric bills or reinvest in other parts of the community.
- Operational, managerial, technical and maintenance responsibilities are also shared by forming a mentor/apprentice style relationship between the community members and the utility that apprentices community members in all aspects of the operation of the community utility.
- Municipality partners with community to provide zoning and political assistance and provide access to available community land for locating the turbines.
- Develop an educational community partnership to provide K-12, community college and university training in support of all aspects of operation of the community utility including business activities, technical, operational and maintenance/service activities. Include job, career and professional training as well as community and professional seminars inclusive of activities for K-12 and college level clubs, extra-curricular activities and competitions [12, 15, 16].

- Community construction and ongoing operational jobs to be legally reserved via ordinance for only the community members that live within the bounds of the community. Use the concept of community enterprise zones to accomplish this task. These are to be modeled similar to the business enterprise zones currently being used in the State of Michigan.
- Commitment to financing through local member banks and credit unions located only in the community area.

The prime directive of the community collaboration is to create an economic engine that will add value to the community by providing business partnership opportunities to the community members as well as jobs [29], technical and business education, apprenticed partnership and mentorship in all aspects of the operation of the system as well as provide direct cooperative style financial benefits

The educational aspect of the model includes training appropriate for middle and high school, community college and university levels that is either preparatory in nature or required to fulfill requirements to support job functions within the cooperative. These job functions include the technical disciplines such as the skilled trades as well as service and maintenance jobs, on through clerical, administrative, and professional disciplines such as finance, management, accounting, human resources, engineering and others [29]. It is necessary when planning the project that the educational program be developed in support of its long term viability.

To support the educational aspect of the Community Wind Power Cooperative model a formal alternative energy/sustainable community program should be set up by the community cooperative in partnership with the State of Michigan for grades K-12. Each school should be funded to develop its own independent alternative energy/community sustainability program. Funding to support alternative energy champions at each high school within the community should be provided. Ideally two or three of the champions should be assigned as to be liaisons between the schools, cooperative and municipality to insure that the school program is meeting expectations. This is a model that has been successfully applied in California schools [4, 12, 15, 35-37].

In terms of the community college and university training it should be closely coordinated with the wind power cooperative management and labor force. This is in order to be sure that all of the necessary trade, administrative, business, finance, engineering, and other professional disciplines required to run the business are being properly supported and that the curriculums are appropriate to meet the businesses needs for producing local talent to support the business.

Beyond paying attention to education we propose doing smaller projects, first which is a proven method in Asia with which to gain experience [16, 17]. From that experience we propose developing a template which includes all of the best practices identified on the smaller projects. From there we grow the model and expand its deployment in a controlled and measured manner in order to insure incremental and ever increasing success. Our model demonstrates community collaboration can be not only be profitable but also provide jobs, security, socio-economic benefits but also ecologically sustainable community benefits for everyone in the community. Also employed is the use of a PPA Power Purchase Agreement with its utility. This agreement allows for the cost of the system to be paid back in a new way. First the power used is all that is charged by the utility as one part of the payment. Second the capital costs are treated separately and a 2nd payment schedule is charged for the cost of the capital, after all tax credits and rebates have been applied [16].

The effective use of this concept has allowed the district to be charged a lower rate. For instance, the Los Angeles Community College District (LACCD) example shows that the district is charged at 13 cents per kWh instead of the standard 16 cents per kWh [16]. This has resulted in a \$9 million dollar savings for the district per year. In addition because an accelerated 5 year depreciation schedule is being used and the original contract allowed for the district to purchase the entire system after year 5, that after that time if they decide to execute their option to buy, that they would now take ownership and have reduced its energy use bill to nothing at that point. Of course the system will be older and require maintenance, but it would be at a much lesser rate than would otherwise be available to them [16]. As previously stated the people part of this equation or “partnership” is by far the most important element of making this project a successful one at the community level. Financing part in the Detroit Model shall consist of 3 components as in the LACCD model [16]. First is the “power unit used” payment model that is composed of the monthly per kilowatt hour charge we pay for the power we use that is associated with the financed components of the project. The second component is the payment that is charged for the financed component of the project that is amortized over a period of usually 15 years or more. This model provides a financing package that allows the loan portion to be paid off over time at which the payments go to zero. The last component is a buyout component that allows the city to purchase the system after five years or optionally anytime thereafter. This model also gives 3rd party financial investors an opportunity to provide the financing to the community and take the depreciation, incentives and tax rebates while assuming the risk of the project financing. It also however provides the ability for the community to benefit from the financial investors by way of receiving lower payment terms than would otherwise be made available to them by using this method [16].

6. Detroit and south eastern michigan community cooperative wind energy model: an example

A discussion of applying the proposed model in the Detroit area is given in this section. The model shall be put in the context of providing direct economic, social, and ecological benefits for the community via implementation of solar, wind and hybrid infrastructure projects within the community. The goals are as follows:

- Develop a model for the implementation of renewable community based wind power as related to sustainable community development synergies, their effectiveness, costs and acceptance.
- Promote and integrate the 3E's + 1E sustainability dimensions previously referenced, into our model [5].
- Include an optimized continuous improvement process in our sustainable community development model [17, 20].
- Define the community impacts and outcomes [9, 10, 16].

Before presenting the details of the model we present a brief review of Detroit's current socio-economic, geographic, demographic and environmental state of affairs. We hope this will give the reader a contextual understanding of why we are now at a critical tipping point where truly innovative socio-economic initiatives can be launched to provide previously unheard of levels of advancement for the citizens of Detroit and then copied and applied in other communities throughout the state of Michigan.

Detroit in 2011 is a city of 713,777 residents living in a 139 square mile area. This is an area that would include the combined areas of San Francisco (46.69 sq. mi.), Boston (48.43 sq. mi.) and Manhattan (22.96 sq. mi.) leaving 20 over square miles left over [6]. It is a city that has lost 61.4% of its population since 1950 when it was at its height of growth. It has a population density of about 5,135 people per square mile on average which is high compared to other cities such as Dallas with 3,400/sq. mi. and Phoenix with 2,900/sq. mi. However, Oakland County a suburban neighbor of Detroit has a population density of 1,400/sq. mi [6]. The greater Detroit region including its combined suburbs has a population of 4.4 million and has grown to that level from 3.9 million in 1960 [6]. Its form of government is referred to as a strong mayoral/city council form of government. Detroit has an average of 2.74 persons living in each household.

Of the total of 139 square miles of property within the city limits, 40 square miles is vacant. Most of this land is defined by smaller parcels ranging from 40' x 40' to 2.5 acres in size [6]. However much of that land is adjacent to municipal owned property, school property and utility and commercial/industrial park owned property. With the above in mind there are several aspects of the Detroit Model which aspire to take advantage of the above opportunity which is unique in Detroit's history and to benefit the local members of Detroit's communities and neighborhoods.

The model as we have previously stated and which we further elaborate upon later in this chapter is predicated upon the partnership between local communities within the Detroit region and their municipalities, utilities, schools and local businesses. In support of this effort the model proposes the use of land banking, an idea of Dan Kildee the treasurer of Genesee County, MI [6]. It simply states that vacant land be put back into productive use by giving it back to the community for free via annexation, for worthy community projects. It is an offshoot of the tried and true homesteading philosophy that our country was founded upon. By allowing the community to use this property for the generation of electricity for their members it would provide them with all of the afore-mentioned socio-economic benefits. This property can also be coupled with other municipal, school, utility, and local business properties to create urban wind and solar farms consisting from 1 to 10 (100 kW – 2 MW) wind turbines and from 5kW up to 100 kW solar arrays as well.

The property that is given to the community can but does not have to be located within the community itself. It can consist of one large parcel; or, it can be made up of several smaller geographically disconnected parcels located in different parts of the community or even the city.

The important thing is that each of them be annexed and put under the jurisdictional ownership of a particular community for their use and benefit.

Typically a given parcel or geographically dissociated parcel(s) located within the community or elsewhere in the city will have between 1 and 10 turbines of from 250 kW to 1 MW each and possibly 1 to 5 solar arrays of the similar size in power. Also note that hybrid models such as using wind and solar power together are capable of providing power than either of them are alone. When the wind is blowing the sun may or may not be shining and vice versa.

Thus, together they can supply power for longer periods than either can provide by themselves. However, if the wind is not blowing or the sun is not shining then neither can provide power. In this case the grid would still supplement the required power.

Furthermore, a typical Michigan home as of 2009 uses about 644 kWh of energy in average per month based on the statistics provided by the EIA (U.S. Department of Energy's, Energy

Information Administration). This means that a 1 MW wind turbine or solar array could support under average circumstances (i.e. 25% capacity factor, meaning that it can supply 25% of the 1 MW of rated power for the turbine on average throughout each day) about 250 homes could be supported per 1 MW turbine. This is a rough “average”, and doesn’t consider peak usage periods, or better capacity factors, but is sufficient to demonstrate how many houses in Detroit, MI might be able to be supported by each turbine. Now remembering that the average population density in Detroit is very high at 5,135 people per square mile and that the average household has 2.77 persons living in it. In other words, there would be approximately 1,853 households per square mile that we would need to provide power to within that area. This would require an average of 7.5 1-MW turbines per square mile.

The Detroit Model does require however that the units be located close enough to the community that they are easily accessible to the community workforce and visible to the members of the community. This could mean that they are up to 5 miles away depending on their size as they are highly visible for quite a distance. Preferably however land could be provided adjacent to the community given the amount of vacant land, utility, school, business park and municipal property previously discussed.

All of these turbines would also power the grid and add to its present capacity within the city, making it much more robust, reliable and capable of withstanding power failures because each turbine in the grid is backed up by all of the others. The main point is that the Wind Cooperative location is annexed or the property owners are given ownership rights by the municipality to take advantage of the Community Enterprise Zone benefits discussed earlier.

Larger turbines (e.g. 2-3 MW) would of course allow for fewer turbines to be required, however for aesthetic and social reasons we choose to use the smaller units so that they are not as imposing and don’t cause as much controversy as the larger units potentially could.

The power generated shall provide the community with “member cost managed” electricity for the benefit of local housing, public community projects such as urban farms [25], local community organizations, schools, and businesses [6]. It shall also provide its members with income from the sale of excess energy not used by the community, but sold on the external market for profit or as REC’s (Renewable Energy Credits) which can be traded on a renewable energy commodity exchange.

In addition the partnership shall provide local education, training and jobs for the members of the local community. These jobs shall include the skilled as well as professional positions needed to own, operate and manage the wind collaborative as a business in partnership with the utility. The jobs and educational programs needed to support them include: accountants, business/operational and technical managers, electrical, construction and mechanical skilled trades, electrical, mechanical and service technicians, engineers, community outreach personnel, school alternative energy liaison’s and many other disciplines.

All of these career opportunities shall be reserved for members of the local community, who live within its “Community Economic Enterprise Zone”, that being a specified geographic zone defined by the local community and municipality by ordinance. The municipality and state shall provide, via legislative action tax incentive to those living within the zone for a period of 7 to 10 years just as they presently do for businesses willing to establish operations within the currently popular “Economic Enterprise” and “Free Trade Zones” within the state of Michigan. The difference here is that the tax benefit will be provided to the

individuals within the community as an incentive to commit to live, work and participate in the community wind collaborative for a stated period of years. This part of the Detroit Model is intended to bring intrinsic value to the community that is to be viewed as a tangible benefit for people wanting to become part of the community while at the same time providing them with the socio-economic and educational benefits that the community has to offer its residents.

In the long term the model's "local community member's only" zone concept first stabilizes and then enhances property values, brings attention to the neighborhood and provides the magnet for being a desirable place to live, find educational opportunities, jobs, potential for business profit, lower electric rates, community pride of ownership and community sustainability. These values are specifically intended to be reflected in the enhanced worth of the household properties within the neighborhood should they ever be put on the market for sale by the individual owners. Favorable tax incentives are intended to attract people to become members of the community. Ultimately the intention is to provide a desirability and quality of living for each member within the community that impacts them in a very personal and yet community oriented way.

When considering the Detroit Model it is important to recognize that it is first of all a localized neighborhood based model. It is a model that is intended to be championed and driven by the local residents of the community. It must ensure that the "residents drive the process" [24]. It is imperative that there be effective community involvement at every stage of the process and that their concerns are addressed at every level. It is equally important to garner the support of the local municipality and seek guidance from it in order to achieve the goals of the project as defined and championed by the community members [10, 22, 23].

In order to accomplish the above the Detroit Model proposes using "Community Champions" to represent the voice of each of the key constituencies within the community. These champions are people nominated by their constituency to actively represent, engage, and ultimately integrate each of their particular group's interest's and vision into the fabric of the community wind power cooperative. The objective is to have these champions interact on a regular basis which consequentially will then result in a most effective tool for promoting the goals and objectives of the cooperative as a whole. In this way all of the constituencies within the "community" are genuinely represented and their voices heard. More so however as the project progresses throughout its life, each of these constituencies have ongoing involvement in the project which allows for more effective communication between each of their groups.

This aspect of the champion idea is where its true power resides. The champion board is not only expected to have its regular member meeting, but also is expected to take their meetings to each of the member constituencies to inform them of the group's progress on a regular basis. In this manner each of the individual constituencies will be assured to have regular input into the process as well as be regularly informed of the progress of the group as a whole. Mean while the individual champion for each group are expected to regularly inform their own constituency of their individual progress. In this way each constituency has the opportunity to voice their individual concerns while also being able to contribute their unique abilities and talents to the project.

The concept of using an ongoing board of directors insures that open communication of the goals and objectives of the collaborative are being effectively met throughout the life of the wind power collaborative.

Yearly elected collaborative board of directors (i.e. champions):

- Community Champion(s) [26]
- Community Special Interest Champion(s) [26]
- Religious Community Champion
- Municipal Champion – Mayoral and City Council Champion [22, 26]
- State of Michigan Champion – Representative of congressional district staff
- Utility Champion
- School Champion(s) – One per school, where alternative energy curricula is being taught
- Business Community Champion
- Bank/Financial Institution Champion
- Legal Community Champion

The Detroit Model is based on a localized community enterprise zone concept that is especially well suited to meet the socio-economic needs of many Southeast Michigan communities today. We believe that because the state of Michigan is currently experiencing here-to-fore unheard of negative dynamics in regard to its socio-economic viability that it is precisely due to these factors that the region is optimally positioned for the introduction of the Detroit Model. Perhaps at no other time in its modern history are so many people in the region united in purpose and conviction because of the commonality of economic cause that they have experienced. We believe that because of these factors the model is unexpectedly and yet opportunistically positioned to address the socio-economic needs of the community. We base this opinion on the fact that in history it has been noted that in many cases that tipping points occur when certain critical streams of events or conditions converge and present themselves in a city's, country's or even a civilization's field of view as they progress throughout history. These "conditions" are temporal and opportunistic. If as time passes these conditions such as population, demographic, economic status or social condition changes, the window of opportunity also changes and in many cases vanishes forever.

Case in point is in our own country's history. Our forefathers, Thomas Paine amongst them had the foresight in his call to arms book "Common Sense" to recognize that our population of 2,500,000 citizens in 1775 was at a tipping point in regard to knowing when it was of optimal size for our country to stage a rebellion. More-over he was able to see that waiting 50 years hence when the population might become 25,000,000 that we would not be able to stage a rebellion because the population would in his opinion be too large, distributed and unwieldy to focus their attention on a common cause. There were of course several other critical factors such as the level of industry and commerce that we had achieved, the support of the population for a popular cause, the experience the new country's army officers had gained over the previous 20 years fighting the Indian Wars, and not the least of which, the will of the people in both the U.S. as well as lack there-of in England, as well as other factors that opportunistically converged and were so very obvious to Mr. Paine for him to express that it was exactly the right time to attempt the rebellion. He intuitively knew that our country had reached a tipping point and just like in our own times there was the recognition that certain critical factors and circumstances might never converge again. As a man with foresight, vision and not afraid to lead, he intuitively knew that if these temporal factors changed in the predictable manner that he anticipated, that the window of opportunity could and most probably would vanish forever, unless he acted upon the opportunity. We

need to heed this lesson and apply its wisdom in modern times when we see these opportunities borne out of painful experience that confront us and make use of them in order to take action and leverage our cause.

The point is that when the time is right it takes foresight and leadership to recognize when it is the optimal time to act in order to not miss the window of opportunity being presented to us, even if it is borne out of painful experience. This is what the Detroit Model attempts to accomplish by providing a roadmap for addressing the rebirth of Southeastern Michigan's communities. The difference is only that we use the community wind power collaborative concept as the vehicle to achieve the goal. It is important to note however that it is a model that is untested up to now, in any highly urbanized city setting. There are large projects such as the LACCD project previously mentioned, but none of the smaller, more modular scale and intentionally tailored to be easily replicable as the Detroit Model proposes. As such we propose that the initial project(s) to be limited in size and scope as follows:

- Size will vary but be based on relatively small area neighborhoods or subunits thereof within the city. This is crucial especially in the initial phases of the models introduction to the city. Initially two neighborhoods should be selected via a Six Sigma Process through collaboration with the city leadership and Wayne State Engineering and Urban Planning department personnel.
- All of the previously mentioned pre-project preparation group dynamic management tools shall be applied in the model.
- Six Sigma, Lean and Best Practices including Toyota A3 project status reports shall be integrated into the methodologies of the project in order to optimize results. This includes establishing reliable timelines and formalized process management procedures for all of the key performance goals and milestones established for the project [4, 20].
- Currently there are several community revitalization projects being implemented within the city. The three best of these should be considered as possible implementation sites. And one selected for implementation of the model.
- The size of the neighborhood should depend on the mix of residential, commercial and industrial usage within the neighborhood and its physical footprint should be kept to a relatively small size for sake of simplicity and ease of management for the initial project.
- We recommend 1 square mile quadrants or less. By limiting the project to one of relatively small size such as this, effective understanding of the outcome(s) can be appreciated, firmly understood and finally formalized into a "How To" best practice guide.
- This initial project is to be considered an alpha test site project (with the community's knowledge and buy in of course).
- That "Before" and "After" snapshots of the project should be documented in order to provide a comparative validation to the community, stakeholders, partners and outside observers for the justification of the project. And to provide the project itself with a "Vision".
- Future projects shall then be "cookie cut" with appropriate modifications based on the "How To" best practice guide described above. It is important that this "smaller is better" regimen is adhered to because it provides for the greatest chance for success, as opposed to trying to implement a project on a larger scale. Once the model is optimized, then it is appropriate to expand the size and scope of the future projects to be considered.

- Initially a “community outreach” is required after the sites are selected. Continuous and ongoing meetings shall be scheduled to include, inform and involve the public. All interested and “invested” partners are reached-out to in order to develop a robust collaborative environment and group.
- Initially meetings will focus on conveying the concept of the community sustainability model in order to educate the community on how collaborative efforts of this type are formed and how they operate. This is a crucial step, as it sets the tone, guidelines and behavioral attitudes before commencing with the work of developing the community plan. This phase can take up to a year to complete.
- A “vision” for the community shall be established. It should include the E3 + 1 Community Partnership concept in its charter. The entire focus should be put on how the wind, solar and utility initiative shall benefit the community and its partners.
- Legal entities shall be formed between the community and utility to form a 50/50 community cooperative business structure. This idea is a cornerstone of the model. From it several other key advantages to the community and the utility shall evolve.
- Several key subgroups shall be formed within the cooperative as follows and they shall each be responsible for developing their part of the overall plan:
 - Community/Municipality/Legal to form a partnership to manage the political and legal aspects of the project at local level
 - Community/Federal/State/Local Government and Religious community to work on the socio-economic aspects of the project and grant submission process to the state and federal govt.
 - Community/Utility to form a partnership that will allow for business and technical mentorship, apprenticeship and profit sharing.
 - Community/Utility/Education to form a partnership to develop a K-12, community college and university training program to support the business, operational and technical aspects of the community collaborative.
 - Community/Business/Financial Institution to form a partnership to address the business and financial socio-economic aspects of the partnership. And determine the optimal financial solutions for project implementation.
 - An advisory group consisting of members from each of the stakeholder groups that help guide and focus the project and subgroup activities.
 - The cooperative shall be based on the concept of either a for profit or not for profit model, but the result should be that it provides the community with: Business ownership; Jobs as employees of the utility Educational opportunities to train specifically for all of the disciplines required to operate the power system; Profit sharing from the business opportunity; Lowering of electric bills.; Direct control over the business decisions that are made in regard to management of the power system cooperative thus helping to mitigate the cost of energy for the community.
 - Development of a program similar to the Detroit Edison Green Currents Solar purchase program is a focus and will help the community lower and manage its energy costs. This is a program that gives the community access to funding for alternative energy projects within Michigan communities, which is paid for by DTE.

Ultimately through use of instruments such as those discussed in the LACCD example, the Detroit model shall seek and make every effort to make the project “pay for itself” through careful financial planning of the project financing package. The goal is to lower monthly

energy bills such as the LACCD project did and gradually gain complete financial ownership of the system over a period of years, thus at that point in time allow for even further reductions in cost by separating the monthly energy unit delivery charges from the cost of paying for the assets over time via 3rd party investors (community partners) through optimized financial loan agreements that get paid back over time, thus leaving just maintenance costs remaining for the life of the system, leaving the community with a reduced bill at the end of the month for this aspect of the project as well.

This coupled with the financing being provided by the community's own "Common Good Bank" discussed previously, will allow the community members to not only partake in the wind power project's financial, jobs, educational and socio-economic benefits, but also give them the same opportunity to share in the same type of benefits derived from the community cooperative bank in which they have their own ownership interest.

As previously mentioned we recommend the integration of the Six Sigma and Lean concepts into the model. Six Sigma is a continuous improvement methodology that optimizes processes and quantifies expected results in a very deterministic way in terms of the project's execution as well as its financial return. This methodology has proven to be very successful and has helped to streamline the coordination and implementation of community wind projects in multiple cities all across the country [4, 17, 20].

7. Discussion and conclusion

A socio-economic model of community based wind power systems was given in the chapter. The application of the model in the Detroit area was also discussed in this chapter. In order to "ground" the model in practical and not just lofty terms it is necessary to include a business oriented perspective and approach to solving the challenges that developing community wind power present. This involves understanding the "how to" part of the equation that is necessary in order to take action while using measured and yet community sensitive techniques and methodologies to achieve the goals. Business models exist for satisfying this requirement and will be included in our model as well.

It is also of paramount importance to insure that the group dynamic is stable. The human action model makes it clear that it may be impossible to progress to the stage of effective group collaboration without accommodating group dynamics first. The "group dynamic" must supersede all other dynamics involved in the project including the technical dynamic. As a primary variable in our effort it can prevent us from achieving project success despite the quality or success of other dynamics involved in the project. The human action model provides us with insight and concrete solutions for addressing the group dynamic before "team dynamics" issues become critical.

Above all the Detroit Model is a model for establishing a socio-economic engine that uses community wind power cooperatives as the vehicle for creating community jobs, education, socio-economic wealth and pride of ownership that is supportive of community sustainability ideals that will result ultimately in a vibrant and successful future for the residents of the communities in Southeastern Michigan.

8. References

- [1] The White House, Office of the Press Secretary, "FACT SHEET: The State of the Union: President Obama's Plan to Win the Future," <http://www.whitehouse.gov/the>

- press-office/2011/01/25/fact-sheet-state-union-president-obamas-plan-win-future, Accessed January 25, 2011.
- [2] States with Renewable Portfolio Standards, The Office of EERE, DOE, http://apps1.eere.energy.gov/states/maps/renewable_portfolio_states.cfm.
- [3] Windustry Community Wind Toolbox. pp. 12-14. Available Online: http://windustry.org/sites/windustry.org/files/Full_CWT.pdf
- [4] Billman, L. (2009). Rebuilding Greensburg, Kansas, as a Model Green Community: A Case Study (National Renewable Energy Laboratory).
- [5] Edwards, A. R. (2005). The Sustainability Revolution. BC Canada: New Society Publishers.
- [6] Gallagher, J. (2010). Reimagining Detroit, Opportunities for Redefining an American City. Detroit, MI: Wayne State University Press.
- [7] Gipe, P. (2004). Wind Power, Renewable Energy for Home, Farm, and Business. White River Junction, Vermont: Chelsea Green Publishing Company.
- [8] Gipe, P. (2009). Wind Energy Basics, A Guide to Home and Community-Scale Wind Energy Systems (Second Edition ed.). White River Junction, VT: Chelsea Green Publishing Company.
- [9] Hubbard, A., & Fong, C. (1995). Community Energy Workbook, A Guide to Building a Sustainable Economy. Snowmass, Colorado: Rocky Mountain Institute.
- [10] Roseland, M. (2005). Toward Sustainable Communities, Resources for Citizens and Their Governments (Revised ed.). BC, Canada: New Society Publishers.
- [11] Stewart, C., Smith, Z., & Suzuki, N. (2009, December 2009). A Practitioners' Perspective on Developmental Models, Metrics and Community. *Integral Review*, 5(2).
- [12] U.S. Department of Energy. (2009). Wind for Schools: A Wind Powering America Project (GO-102009-2830). Washington, DC: U.S. Government Printing Office.
- [13] Walker, G., & Devine-Wright, P. (2007). Community renewable energy: What should it mean? Available Online: http://www.sociologia.unical.it/gunder_frank/walkercommunityenergy.pdf.
- [14] Walker, G., Devine-Wright, P., Hunter, S., High, H., & Evans, B. (2009). Trust and community: Exploring the meanings, contexts and dynamics of community renewable energy. http://www.staffs.ac.uk/schools/sciences/geography/link/IESR/staff_honfellow_s_gn.shtml.
- [15] Baring-Gould, I., Flowers, L., Kelly, M., Barnett, L., & Miles, J. (2009). Wind for Schools: Developing Education Programs to Train the Next Generation of the Wind Energy Workforce (NREL/CP-500-45473). . .
- [16] Clark II, W. W. (Ed.). (2010). Sustainable Communities. New York, New York: Springer Science+Business Media, LLC.
- [17] Kaufmann-Hayoz, R., & Gutscher, H. (Eds.). 2001. Changing Things – Moving People, Strategies for Promoting Sustainable Development at the Local Level. Germany: Birkhauser Verlag
- [18] Community Sustainability Guide, 2010. Affordable Housing Program, FHLBank Pittsburg. Available Online: <http://www.fhlp-gh.com/pdfs/cid/ahp/2010-Community-Sustainability-Guidebook.doc>
- [19] Community Sustainability Guide, (2010). Affordable Housing Program, FHLBank Pittsburg. Available Online: http://www.bouldercolorado.gov/files/final_sss_plan_060608.pdf
- [20] B. Wortman. (2008). Comprehensive Lean Six Sigma Handbook, Villanova University: Quality Council of Indiana

- [21] Common Good Finance, (2010). Common good finance: democratic economics for a sustainable world. The Common Good Bank, <http://www.CommonGoodBank.com> Ashfield, MA
- [22] Green Task Force Interim Report, Detroit City Council Presided by Kenneth V. Cockrel Jr. Detroit City Council President
- [23] Bing: Let's move Detroiters into the city's viable areas, Detroit News, 12-09-2010. Pg. 1A
- [24] Right-size the right way, Detroit Free Press Editorial, 12-12-2010. Pg. 28A
- [25] Urban Farmers Still Waiting on City, Detroit Free Press, 11-13-2010. Pg. 1A
- [26] Lesson of Detroiters' trip: Eat, love, play, Detroit Free Press 11-25-2010. Pg. 2A
- [27] P. Gipe. Community Wind: The Third Way, Community Wind Slide Show, 2003. <http://www.wind-works.org/articles/communitywindthethridway.html>
- [28] Pavel, M., (2009). Breakthrough Communities: Cambridge, MA; London, England: The MIT Press
- [29] Lantz, E., Tegans,S. (2009). Economic Development Impacts of Community Wind Projects: A Review and Empirical Evaluation. Boulder, CO. National Renewable Energy Laboratory. Conference Paper NREL/CP-500-45555
- [30] Bolinger, M., (2001). Community Wind Power Ownership Schemes in Europe and Their Relevance to the United States. Berkeley, CA. Lawrence Berkeley National Laboratory
- [31] Bailey, B., McDonald, S. (1997). Wind Resource Assessment handbook, AWS Scientific, Inc., Prepared for : national Renewable Energy Laboratory Sub Contract Number TAT-5-15-283-01
- [32] Lambert, J., Elix, J. (2003). Building Community Capacity Assessing Corporate Sustainability, Total Environment Center
- [33] Editors of E Magazine, (2005). Green Living, the E Magazine Handbook for Living Lightly on the Earth: NY, NY; Plume Book
- [34] Clean Energy Magazine, Guest Editorial: Feolmillbank, Tweed Hadley and McCloy, The American Recovery and Reinvestment Act of 2009, Pg. 8. LLPVolume 3, Issue 2, March/April 2009, Editor Michelle Froese, 255 Newport Drive, Ste. 356 Port Moody, B.C. V3H 5H1
- [35] Wescott, G. (2002). Partnerships for Capacity Building Community, Governments and Universities. Working Together. Elsevier Ltd. Burwood, Australia
- [36] Powers, A. (2004). An Evaluation of Four Placed-Based Education Programs. Education Research Associates. Richmond, VA
- [37] Management Steering Committee, (2009). Preparing the U.S. Foundation for Future Electric Energy Systems: A Strong Power and Energy Engineering Workforce. Prepared by the Management Steering Committee of the U.S. Power and Energy Engineering Workforce Collaborative. IEEE PES Power and Energy Society
- [38] Bolinger, M., Wiser, R., Wind, T., Juhl, D., Grace, R., West, P., (2005). A Comparative Analysis of Community wind Power Development Models. University of California, Lawrence Berkeley National Laboratory, escholarship Repository, Paper LBNL-58043
- [39] Weissman, j., (2004). Defining the Workforce Development Framework and Labor Market Needs for the Renewable Energy Industries. Interstate Renewable Energy Council, Latham, NY. www.ireusa.org
- [40] Global Water Intelligence Magazine, (5-1-2011). China to Double Environmental Spending. Volume11, Issue1, January2010. <http://www.globalwaterintel.com/archive/11/1/general/chint-to-double-environmental-spending.html>

Part 2

Potential Estimation and Impact on the Environment of Wind Farms

Methodologies Used in the Extrapolation of Wind Speed Data at Different Heights and Its Impact in the Wind Energy Resource Assessment in a Region

Francisco Bañuelos-Ruedas¹, César Ángeles Camacho¹
and Sebastián Rios-Marcuello²

¹*Instituto de Ingeniería de la UNAM*

²*Escuela de Ingeniería de la Pontificia Universidad Católica de Chile*

¹*México*

²*Chile*

1. Introduction

For many centuries to date, wind energy has been used as a source of power for a whole host of purposes. In early days it was used for sailing, irrigation, grain grinding, etc. At the onset of the 20th century, wind energy was put to work on a different use: power generation and electricity-generating wind turbines were produced.

Wind turbines do convert the wind renewable energy into electricity, thus becoming a clean and sustainable power generation alternative. There is a large number and wide assortment of wind turbines which, over time, have evolved in its two key areas: capacity and efficiency. The evolution of wind turbines has been boosted thanks to the growing awareness on environmental issues which in turn stems from an equally growing concern over conventional fossil fuel energy sources. Furthermore, high oil prices and other financial incentives are also bearing their respective weights on the issue. Large scale wind turbines in the range 4 to 10 MW are now being developed and used for equipping large-scale wind farms worldwide.

The power developed with wind generators depends on several factors with the noteworthy ones being the height above the ground level, the humidity rating and the geographic features of the area but the chief factor is the wind speed. Therefore, the first step in ascertaining the energy that can be produced and the effects of a wind farm on the overall electricity network calls for a thorough understanding of wind itself.

There are different methods used in estimating the wind potential. This paper is aimed at presenting the impact of various methods and models used for extrapolating wind speed measurements and generate a relevant wind speed profile. The results are compared against the real life wind speed readings. Wind resource maps come as a plus factor.

2. Wind power

Each turbine in a wind farm extracts kinetic energy from the wind. The commonplace literature states that real power produced by a turbine can be expressed with the following equation:

$$P = \frac{1}{2} \rho A v^3 c_p \quad (1)$$

where P is the real power in Watts, ρ is the air density in kg/m^3 , A is the rotor area in m^2 , v is the wind speed in m/s , and c_p is the power coefficient (Masters, 2004). Air density is a function of temperature, altitude and, to a much smaller extent, humidity. The power coefficient is simply the ratio of power extracted by the wind turbine rotor to the power available in the wind. This data is supplied in tabular and, sometimes, graphical formats. Since the power developed is proportional to the cube of wind speed, wind power production is highly dependent on the wind speed resources; thus an understanding of the wind speed variability is crucial if we are to determine the wind resources available at each wind farm location.

3. Factors influencing wind speeds

Empirical evidence has shown that at a great height over the ground surface (in the region of one kilometre) the land surface influence on the wind is negligible. However, in the lowest atmospheric layers the wind speed is affected by ground surface friction factors (Danish Wind Industry Association, 2003).

Local topography and weather patterns are predominant factors influencing both wind speed and wind availability. Differences in altitude can produce thermal effects. Usually the wind speed increases with altitude, so hills and mountains may come close to the high wind speed areas of the atmosphere. There is also an acceleration of wind flows around or over hills and the funnelling effect when flowing through ravines or along narrow valleys. On the other hand, artificial obstacles can affect wind flows. In short, there are two well-defined factors affecting wind speed: *environmental factors*, ranging from local topography, weather to farming crops, etc. and *artificial factors* ranging from man-made structures to permanent and temporary hindrances such as buildings, houses, fences and chimneys.

Natural or man-made topographical obstacles interfere with the wind laminated regime. A low level disruption will cause the wind speed to increase in the higher layers and drop in the opposite layers. In urban areas, a different situation arises: the so-called "island of heat"; an effect that will produce local winds. Due to this island of heat effect, the wind measurements readings at urban meteorological stations are not useful for predicting the wind patterns in other areas adjacent to large conurbations (Escudero, 2004).

The profile of average wind speed at one site is the representation of the wind speed variations in line with the height or distance of the site. Fig. 1 compares wind profiles at the CNA measurement station (CNA, "Comisión Nacional del Agua") in Guadalupe, Zacatecas during a four-month period; in it we can see a display of the profile variations in the months concerned (Torres, 2007). We have noted also that, usually, the wind profile repeats itself year-on-year.

4. Wind speed calculations at varying heights

The initial measurements are generally taken at some ten-metre heights (Johnson, 2001; Masters, 2004), although there are data capture undertaken at lower heights and for other purposes such as agricultural monitoring. The commonly used technique is to estimate speeds at higher altitudes and extrapolate the readings obtained and build-up the site's wind speed profile.

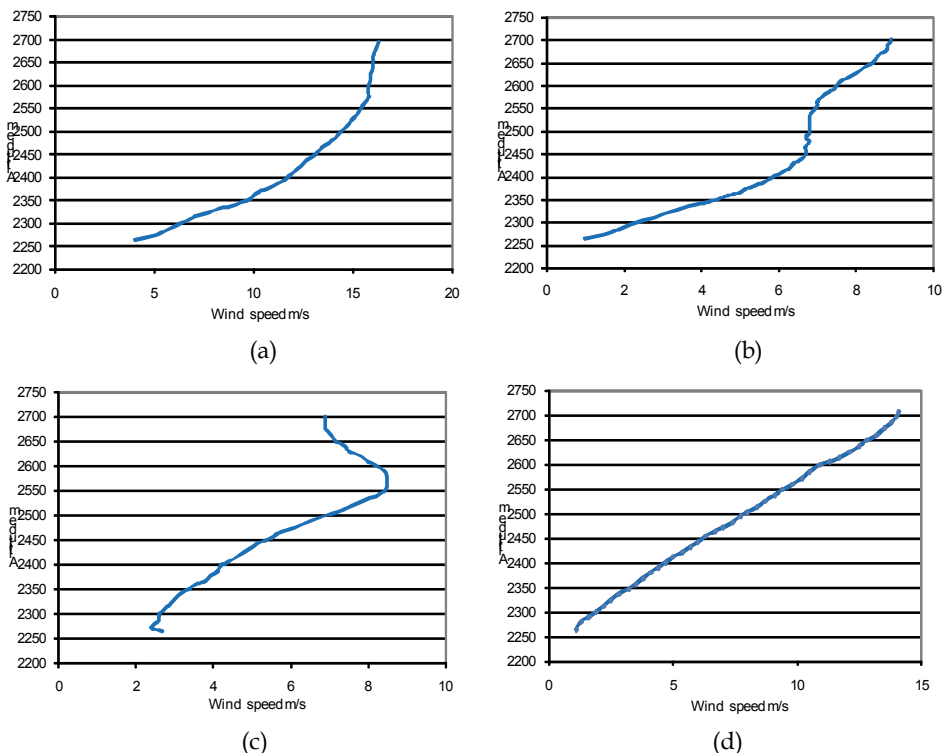

Fig. 1. Typical wind profile monitored at the station of CNA in Guadalupe, Zacatecas during the months of (a) January; (b) May; (c) July; and (d) November

There are sundry theoretical expressions used for determining the wind speed profile. The Monin-Obukhov method is the most widely used to depict the wind speed v at height z by means of a log-linear profile clearly described by:

$$v(z) = \frac{v_f}{K} \left[\ln \frac{z}{z_0} - \xi \left(\frac{z}{L} \right) \right] \quad (2)$$

where z is the height, v_f is the friction velocity, K is the von Karman constant (normally assumed as 0.4), z_0 is the surface roughness length, and L is a scale factor called the Monin-Obukhov length. The function $\xi(z/L)$ is determined by the solar radiation at the site under survey. This equation is valid for short periods of time, e.g. minutes and average wind speeds and not for monthly or annual average readings.

This equation has proven satisfactory for detailed surveys at critical sites; however, such a method is difficult to use for general engineering studies. Thus the surveys must resort to simpler expressions and secure satisfactory results even when they are not theoretically accurate (Johnson, 2001). The most commonly used of these simpler expressions is the Hellmann exponential law that correlates the wind speed readings at two different heights and is expressed by:

$$\frac{v}{v_0} = \left(\frac{H}{H_0} \right)^a \quad (3)$$

In which v is the speed to the height H , v_0 is the speed to the height H_0 (frequently referred to as a 10-metre height) and a is the friction coefficient or Hellman exponent. This coefficient is a function of the topography at a specific site and frequently assumed as a value of 1/7 for open land (Bansal et al., 2002; Masters, 2004; Patel, 2006). However, it must be borne in mind that this parameter can vary for one place with 1/7 value during the day up to 1/2 during at night time (Camblong, 2003). Equation (3) is also known as the power law when the value of a is equal to 1/7 is commonly referred to as the *one-seventh power law*.

Provided there are no significant ground level obstacles, the friction coefficient a (equation (3)) is set empirically and the equation can be used to adjust the data reasonably well in the range of 10 up to 100-150 metres. The coefficient varies with the height, hour of the day, time of the year, land features, wind speeds and temperature. All such findings have emerged from the analysis undertaken at several locations worldwide (Farrugia, 2003; Jaramillo & Borja, 2004; Rehman, 2007). Table 1 shows the friction coefficients of various land spots that, in each case, are given in function of the land roughness (Fernández, 2008; Masters, 2004; Patel, 2006).

Landscape type	Friction coefficient a
Lakes, ocean and smooth hard ground	0.10
Grasslands (ground level)	0.15
Tall crops, hedges and shrubs	0.20
Heavily forested land	0.25
Small town with some trees and shrubs	0.30
City areas with high rise buildings	0.40

Table 1. Friction coefficient a for a variety of landscapes

Another formula, known as the logarithmic wind profile law and which is widely used across Europe, is the following:

$$\frac{v}{v_0} = \frac{\ln(H / z_0)}{\ln(H_0 / z_0)} \quad (4)$$

where z_0 is called the roughness coefficient length and is expressed in metres, and which depends basically on the land type, spacing and height of the roughness factor (water, grass, etc.) and it ranges from 0.0002 up to 1.6 or more. These values can be found in the common literature (Danish Wind Industry Association, 2003; Masters, 2004). In addition to the land roughness, these values depend on several factors: they can vary during the day and at night and even during the year. For instance the reading or monitoring stations can be within farming land; it follows that the height/length of the crops will change. However, once the speeds have been calculated at other heights, the relevant equations can be used for calculating the power or average useful energy potential via different methods such as

Weibull or Rayleigh distributions. The specialist software package available for calculating such data is known as WAsP[®].

Something worth highlighting is that z_0 , for a homogeneous land, can be obtained by means of measurements at two different heights. Once this new z_0 is to hand, it becomes very straightforward to calculate the speed at other heights and the speed profile would be the one expressed by equation (3), thus turning calculations into a much simpler task (Borja et al., 1998).

It is also important to consider that as well as a wind compass rose is used for tracing the map of the amount of energy coming from different directions, a roughness rose is often created for a given site and where the roughness is specified for each directional sector. For each sector an estimate of the roughness is assumed, with a view to estimate how the wind speed does change in each sector due to the varying land roughness (Danish Wind Industry Association, 2003).

It is quite common to extract from the tables a rated value of such roughness factor. However, when these factors are compared against factor calculations you can conclude that the factors shown in the tables are not always accomplished. The common literature is fairly prolific on roughness coefficients used with Tables 2, 3 and 4 being the most commonly used. From the tables it is easy to note the differences among them, and a good sample of such differences is the value allocated to large cities and sizable forest areas.

Roughness Class	Description	Roughness length z_0 (m)
0	Water surface	0.0002
1	Open areas dotted with a handful of windbreaks	0.03
2	Farmland dotted with some windbreaks more than 1 km apart	0.1
3	Urban districts and farmland with many windbreaks	0.4
4	Densely populated urban or forest areas	1.6

Table 2. Roughness classes and lengths (Masters, 2004)

A way forward that allows us to obtain fairly reliable friction and roughness coefficients is to undertake estimates in similar places (proximity and environmental conditions' wise) is to register the wind speed readings from at least two different heights during a reasonable length of time. The friction coefficient a is firstly obtained for two different heights and speeds using equation (3), by:

$$\alpha = \frac{\ln(v) - \ln(v_0)}{\ln(H) - \ln(H_0)} \tag{5}$$

And then by using equations (3) and (4) with the roughness coefficient z_0 being obtained via;

$$z_0 = \exp \frac{H_0^\alpha \ln H - H^\alpha \ln H_0}{H_0^\alpha - H^\alpha} \tag{6}$$

Land features	z_0 (mm)
Very soft; ice or mud	0.01
Calm open seas	0.20
Chopped high seas	0.50
Snow Surface	3.00
Grassland and green areas	8.00
Pasture areas	10.00
Arable land	30.00
Annual crops	50.00
Scant trees	100.00
Heavily forested areas and few buildings	250.00
Forest land covered with large-size trees	500.00
City outskirts	1500.00
Downtown city areas with plenty of high rise buildings	3000.00

Table 3. Roughness lengths for varying landscape types (Borja et al., 1998)

Roughness class	Roughness length (m)	Landscape type
0	0.0002	Water surface.
0.5	0.0024	Completely open ground with a smooth surface, e.g. concrete runways at the airports, mowed grassland, etc.
1	0.03	Open farming areas fitted with no fences and hedgerows and very scattered buildings. Only softly rounded hills.
1.5	0.055	Farming land dotted with some houses and 8 m tall sheltering hedgerows within a distance of some 1,250 metres.
2	0.1	Farming land dotted with some houses and 8 m tall sheltering hedgerows within a distance of some 500 metres.
2.5	0.2	Farming land dotted with many houses, shrubs and plants, or with 8 m tall sheltering hedgerows of some 250 metres.
3	0.4	Villages, hamlets and small towns, farming land with many or tall sheltering hedgerows, forest areas and very rough and uneven terrain
3.5	0.8	Large cities dotted with high rise buildings.
4	1.6	Very large cities dotted with high rise buildings and skyscrapers.

Table 4. Roughness classes and lengths considered by the Danish Wind Industry Association (Danish Wind Industry Association, 2003)

Both friction a and roughness z_0 coefficients are completed for two different measurements and then it becomes feasible to depict the corresponding wind profile and relevant factors for one day, time and year for different wind directions (Farrugia, 2003; Jaramillo & Borja, 2004).

There are locations where it is difficult to match these factors or the results appear to be wrong because they do not show very reliable data. These locations are usually in mountain ranges where, according to national and international recommendations, it makes sense to take the readings at several altitudes during a reasonable length of time.

In 1947 Frost (Sisterson et al., 1983) proved that equation (3) with a value of $a = 1/7$ described good atmospheric wind profiles for heights ranging from 1.5 and 122 metres during almost neutral conditions (adiabatic). However, this data indicates that the values of a drop with the heat (unstable conditions) and increase with a land cooling down cycle (stable conditions). Nowadays the atmosphere trends, below the 10 metre mark, are illustrated easily by means of flux-gradient relationships whenever the land surface features and the momentum fluxes and heat have known values.

5. Case studies

With a view to showing the effectiveness of the extrapolation methods in securing a wind profile, three case studies are thoroughly scrutinised. In such case studies the information shown stems from the monitoring stations at different altitudes. Measurements are used for calculating the wind speeds using the exponential Hellmann law equation (3) and the logarithmic law profile equation (4).

5.1 Base case

This case was extracted from the paper published (Jaramillo & Borja, 2004) in which the average registered annual speeds in year 2001 - at 15 and 32 metres above ground level - were 9.3 and 10.557 m/s respectively. According to such data the friction coefficient a is 0.1673 and the roughness coefficient z_0 , is 0.055. These coefficients are used for calculating wind speeds at 32 and 60 metres. The calculated and measured average speeds are shown in Table 5, with a difference in the estimated speed at 60 metres with the calculated coefficients a and z_0 .

Height	15 m	32 m	60 m
Measured speed [m/s]	9.3	10.557	-
Calculated speed [m/s] with a	-	10.5568	11.7277
Calculated speed [m/s] with z_0	-	10.5563	11.5994

Table 5. Average wind speeds broken down by urban areas

The wind profile obtained from equations (3) and (4) is almost coincidental in the lowest heights but, as shown in Fig. 2, when going over the 35-metre ceiling, the wind speed value

differences start to show up. It is clear that calculated coefficients operate well for the first extrapolation but have a poor accuracy rating for speeds at higher altitudes.

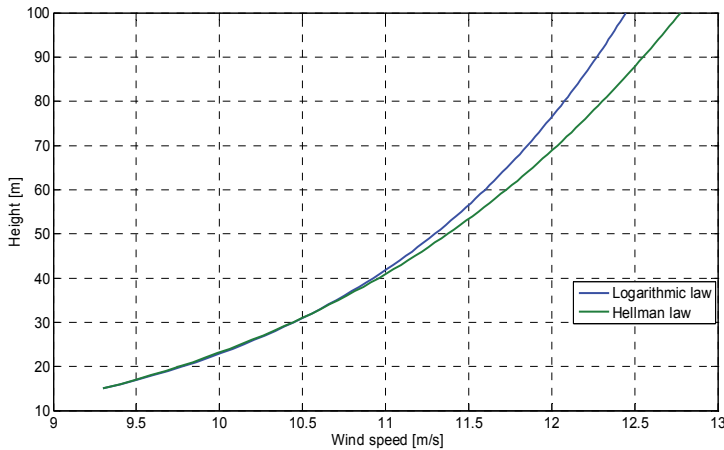

Fig. 2. Wind profile built up using the logarithmic law and the Hellman law applicable to rural areas

The curves of Fig. 2 shows that for a height of 100 m the difference between the speed values using both equations (3) and (4), is for about 0.35 m/s, which would represent a difference of approximately 100 W/m², since the energy content of the wind varies with the cube of the average wind speed, which is why one must be very careful when making extrapolated values using a single method, as this would impact on the estimation of wind resources, and economic aspects.

5.2 Case study: urban areas

In this case we considered the data from two different monitoring stations located in the main Universidad Nacional Autónoma de México (UNAM) campus, one of them known as DGSCA and the other referred to as JARBO (UNAM, 2008).

As regards the DGSCA station, the data was measured along a time horizon of 15 months at 10-minute intervals using two anemometers at 20 and 30 metres over the roof level of a building which is some 15 metres high and surrounded with vegetation whose altitude is some 15 metres over the roof level.

The JARBO station readings were taken over 11 months at 10-minute intervals and using 3 anemometers located at 20, 30 and 40 metres above ground level.

The procedure entailed using the readings for calculating the exponent a for two different heights and then secure the roughness coefficient z_0 using equation (5). The graphic results for both coefficients of the DGSCA station are shown in Fig. 3.

As you may have noted from the previous graphs, the roughness coefficient gets to values very close to zero and it is also distinctly obvious the sharp variations experienced in the roughness and friction coefficients during January and February in 2 different serial years. Thus, this case attracts very special attention and a considerable error will arise when

managing average coefficients. For instance, during the month of May and using equations (3) and (4), the estimated wind profile would be the one shown in Fig. 4. Likewise, Fig. 5 shows the wind profiles for December 2006 and 2007 highlights that although it is the same month for two consecutive years, the readings showed different wind average speeds and profiles.

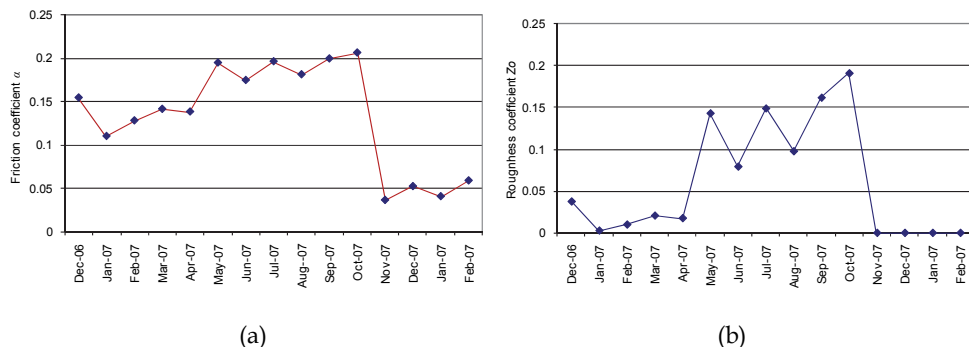

Fig. 3. Variation of the (a) friction coefficients and (b) roughness coefficients, at the DGSCA station

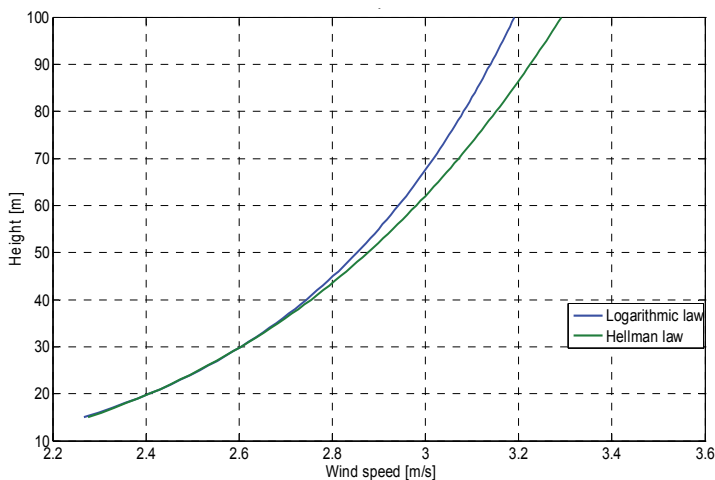

Fig. 4. Wind profile build-up for May 2007 using the logarithmic law and the Hellman law for urban areas at the DGSCA station

Looking at the JARBO station case - and resorting to the same procedure as with the DGSCA station case - friction coefficients were obtained for 20 and 30 metres (a_1), then for 20 and 40 metres (a_2) and finally for 30 and 40 metres (a_3). Such friction coefficients were then used to work out the respective roughness coefficients and their average values. The outcome is shown in Fig. 6.

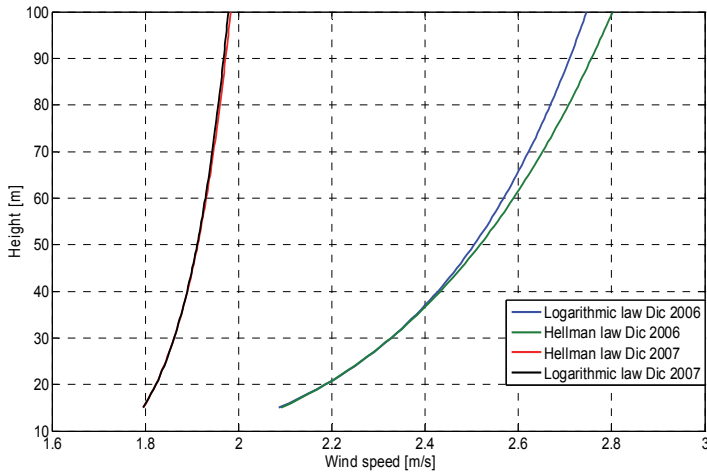

Fig. 5. Comparison of wind profiles for the months of December 2006 and December 2007, compiled with the use of the logarithmic law and the Hellman law for case study B, with all data captured at the DGSCA station

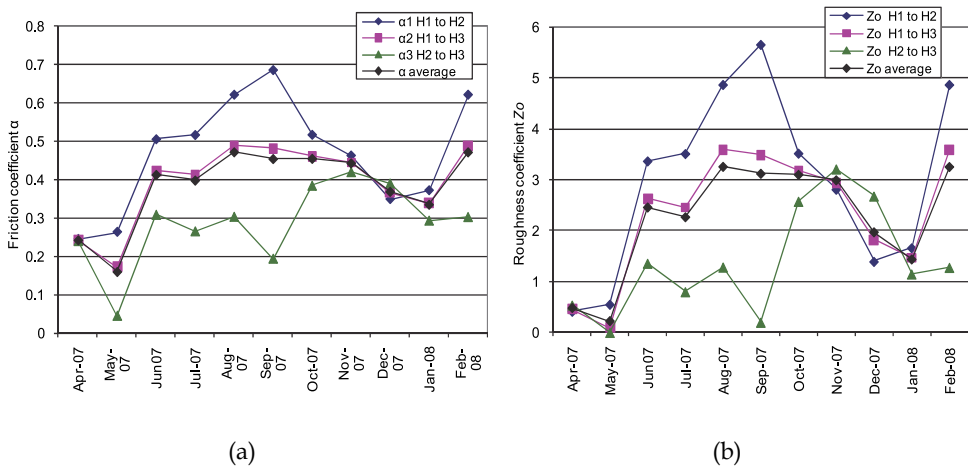

Fig. 6. Variation of the (a) friction coefficients and (b) roughness coefficients for the JARBO station

Furthermore, Fig. 6 shows that the variation of the two monthly average coefficients is remarkable. This is an issue we need to address since it would indicate that the extrapolation method is not the right one or is inconsistent when it comes to sites located within urban areas. The wind profiles for this case are more complex. Indeed Fig. 7 presents the average wind profiles for two different months together with the coefficients' average values. This finding illustrates that wind energy calculation errors using a friction coefficient of 1/7 could become quite significant.

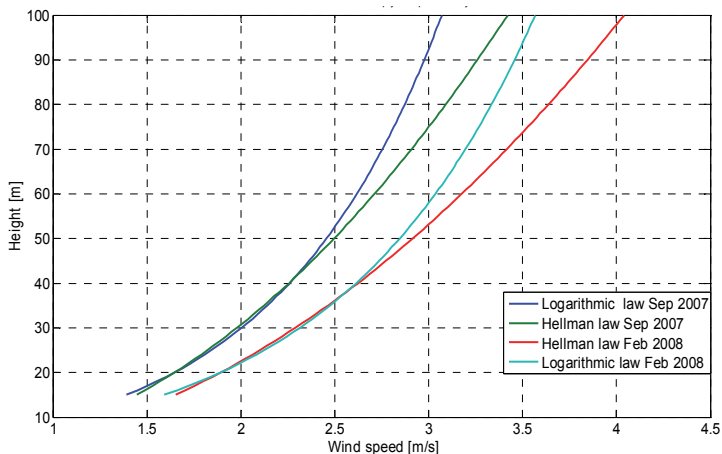

Fig. 7. Comparison of the wind profile for the months of September 2007 and February 2008 compiled using the logarithmic law and Hellman law for case study B, with all data captured at the JARBO station

For completeness sake, Fig. 8 shows the wind resource maps for the JARBO station referred to wind speed and power density at 20 metres high. The wind speed obtained in this area ranges from 1.70 to 2.38 m/s and the wind power variation goes from 7 to 18 W/m², which can hardly make a case for installing a wind turbine.

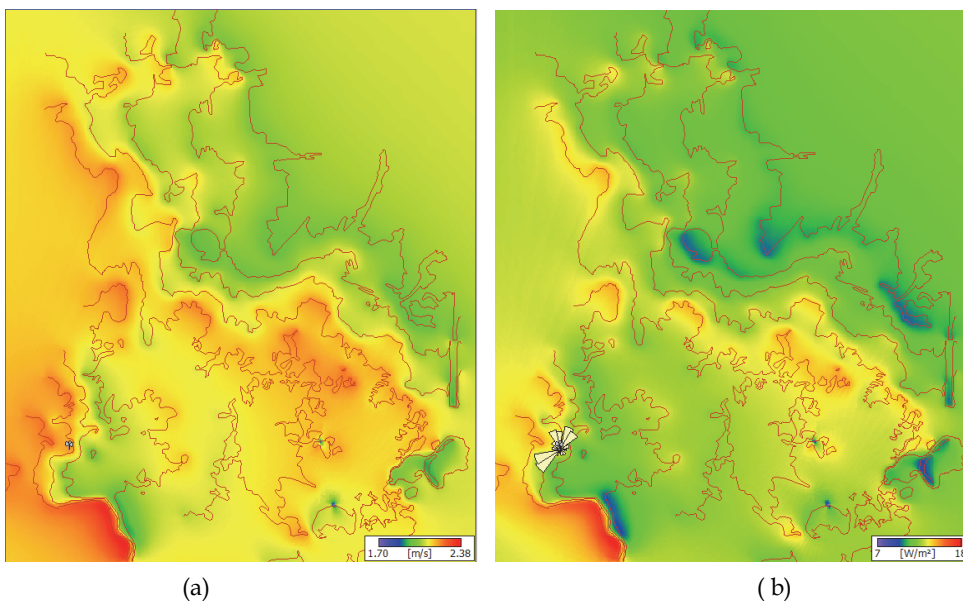

Fig. 8. Wind resource maps for (a) wind speed and (b) power density at the JARBO station produced with the use of the WAsP package

5.3 Case study: rural areas

In this case, the surveyed data stems from measurements taken at a monitoring station located in the UAA-UAZ rural and farming area (Medina, 2006; IIE, 2008). These readings were taken at three different altitudes, namely 3, 20 and 40 metres above ground level. Three friction coefficients were obtained from this data while resorting to equation (3) at 3 and 20 metres (a_1), at 3 and 40 metres (a_2) and, finally, at 20 and 40 metres (a_3). With these friction coefficients the relevant roughness coefficients and their average values were calculated using equation. (6). Thereafter we calculated the annual average values for the friction and roughness coefficient at 0.240 and 0.181 m respectively. The average speeds of every month and the annual average were calculated with the use of both friction and roughness coefficients. We then undertook a comparison between calculated and measured data at 20 and 40 metres high and we identified some variations. Tables 6 and 7 show the sets of calculated and measured data as well as highlighting the differences between them; in some cases in excess of 8%, as shown in the average speed columns calculated for 40 m (V_3 in August, column 4 from Table 6 and column 5 from Table 7) with both friction and roughness coefficients at the H_1 and H_3 altitudes.

Month	V_1 (1)	V_2 (2)	V_3 (3)	a_1 (4)	a_2 (5)	a_3 (6)	Z_0 (7)	Z_0 (8)	Z_0 (9)
August-2005	2.02	3.92	4.25	0.350	0.287	0.117	0.400	0.288	0.005
September 2005	2.53	4.55	5.03	0.309	0.265	0.145	0.279	0.218	0.028
October 2005	2.22	3.99	4.47	0.309	0.270	0.164	0.278	0.233	0.063
November 2005	2.04	3.78	4.34	0.325	0.292	0.199	0.325	0.302	0.186
December 2005	1.75	3.66	4.14	0.387	0.331	0.178	0.521	0.445	0.101
January 2006	2.20	4.18	4.63	0.337	0.286	0.148	0.360	0.284	0.032
February 2006	2.23	4.10	4.62	0.321	0.281	0.172	0.312	0.268	0.085
March 2006	2.92	4.83	5.47	0.265	0.242	0.180	0.165	0.155	0.107
April 2006	2.71	4.39	4.9	0.252	0.227	0.159	0.137	0.119	0.051
May 2006	2.63	4.34	4.85	0.264	0.236	0.160	0.162	0.139	0.055
June 2006	3.06	4.77	5.21	0.234	0.205	0.127	0.100	0.075	0.011
July 2006	2.84	4.40	4.91	0.231	0.211	0.158	0.095	0.086	0.051
Annual average	2.43	4.24	4.73	0.299	0.261	0.159	0.261	0.218	0.065

Notes:

- (1) Speed averages, at $H_1 = 3$ m, in m/s
- (2) Speed averages, at $H_2 = 20$ m, in m/s
- (3) Speed averages, at $H_3 = 40$ m, in m/s
- (4) Friction coefficient, monthly average using measurements at H_1, H_2, V_1, V_2 and Eq. (5)
- (5) Friction coefficient, monthly average using measurements at H_1, H_3, V_1, V_3 and Eq. (5)
- (6) Friction coefficient, monthly average using measurements at H_2, H_3, V_2, V_3 and Eq. (5)
- (7) roughness coefficient, monthly average using measurements at H_1, H_2, V_1, V_2 and Eq. (6), in m.
- (8) Roughness coefficient, monthly average using measurements at H_1, H_3, V_1, V_3 and Eq. (6), in m.
- (9) Roughness coefficient, monthly average using measurements at H_2, H_3, V_2, V_3 and Eq. (6) in m.

Table 6. Data and results for average friction and roughness coefficients in rural areas

Month	a monthly average (1)	Speed to 20 m m/s (2)	Speed to 40 m m/s (3)	Speed to 40 m m/s (4)	Z_o monthly average (5)	Speed to 20 m m/s (6)	Speed to 40 m m/s (7)	Speed to 40 m m/s (8)
August 2005	0.251	3.25	3.87	4.67	0.231	3.51	4.06	4.53
September 2005	0.240	3.99	4.71	5.37	0.175	4.22	4.84	5.22
October 2005	0.248	3.55	4.22	4.74	0.191	3.75	4.31	4.58
November 2005	0.272	3.42	4.13	4.56	0.271	3.65	4.24	4.39
December 2005	0.299	3.10	3.81	4.50	0.356	3.32	3.89	4.29
January 2006	0.257	3.59	4.29	4.99	0.225	3.82	4.41	4.83
February 2006	0.258	3.64	4.35	4.90	0.222	3.85	4.45	4.73
March 2006	0.229	4.51	5.28	5.66	0.142	4.74	5.40	5.51
April 2006	0.213	4.07	4.72	5.09	0.102	4.25	4.80	4.97
May 2006	0.220	3.99	4.65	5.06	0.119	4.18	4.74	4.93
June 2006	0.189	4.38	4.99	5.44	0.062	4.56	5.11	5.34
July 2006	0.200	4.15	4.77	5.05	0.077	4.31	4.85	4.95
Annual average	0.240	3.80	4.48	5.00	0.181	4.01	4.59	4.85

Notes:

- (1) Friction coefficient, monthly average using a_1, a_2, a_3 (from Table 6)
- (2) Calculated speed with friction coefficient a_1 (from Table 6)
- (3) Calculated speed with friction coefficient a_2 (from Table 6)
- (4) Calculated speed with friction coefficient a_3 (from Table 6)
- (5) Roughness coefficient, monthly average using columns (8), (9) and (10), in m. (from Table 6)
- (6) Calculated speed with roughness coefficient Z_o for H1, H2, V_1, V_2 (from Table 6)
- (7) Calculated speed with roughness Z_o for H1, H3, V_1, V_3 (from Table 6)
- (8) Calculated speed with roughness Z_o for H2, H3, V_2, V_3 (from Table 6)

Table 7. Wind speed data and readings when applying average friction and roughness coefficients in rural areas

Fig. 9 shows, for this case the variation experienced by the friction and roughness coefficients. The variation of the roughness coefficient for the height included in the analysis and for a specific month is also very noticeable (Fig. 10).

As it can be concluded from the data captured in the foregoing figures, in some cases there are important variations when using either average values for the roughness or friction coefficients; it is also noticeable that they experience changes throughout the season or month and with land altitudes.

In this case the wind profiles for both August-2005 and March-2006 on a 3-metre-high basis are shown in Fig. 11. The wind resource maps encompassing the wind speed and power density at this station are shown in Fig. 12. These maps are for a height of 80 metres.

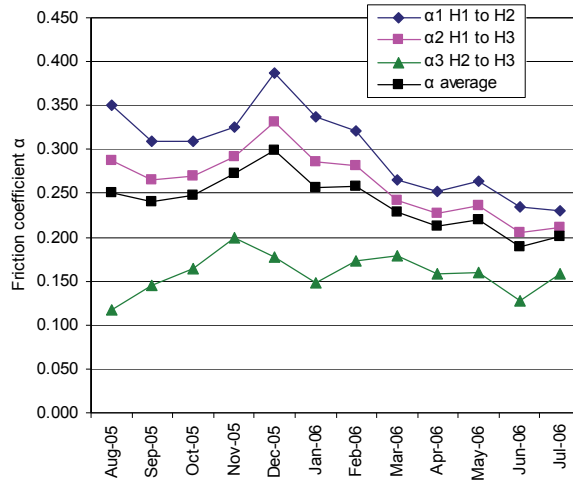

(a)

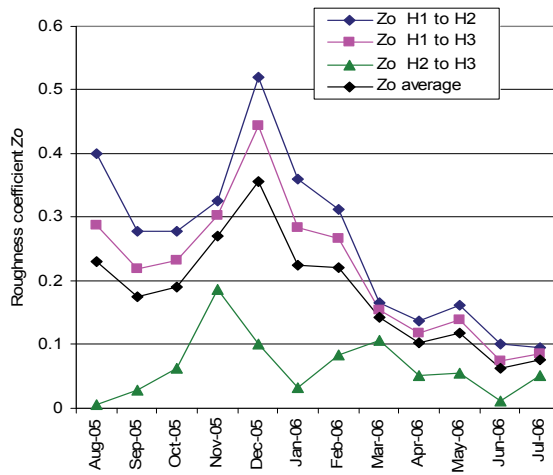

(b)

Fig. 9. Variation of (a) the friction coefficient, and (b) the roughness coefficient in rural areas at different heights

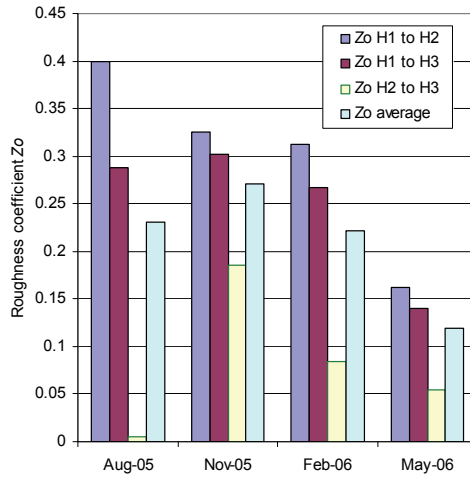

Fig. 10. Roughness coefficient for August 2005, November 2005, February 2006 and May 2006

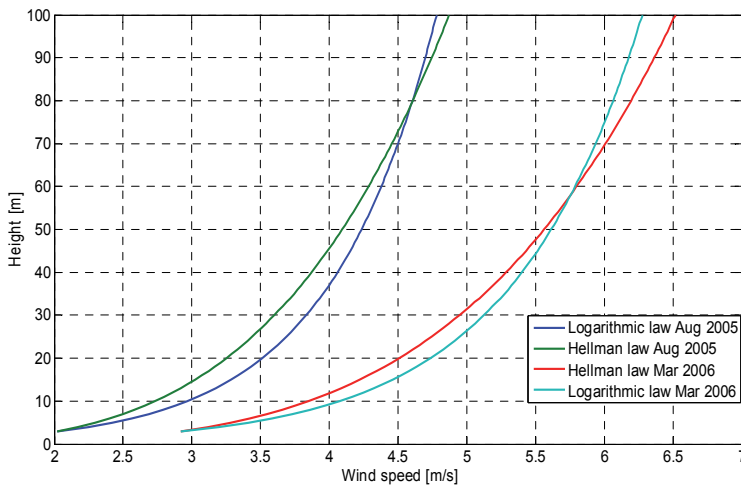

Fig. 11. Comparison of wind profiles for the months of August 2005 and March of 2006 compiled with the use of the logarithmic law and the Hellman law for rural areas, all data captured at the UAA-UAZ station

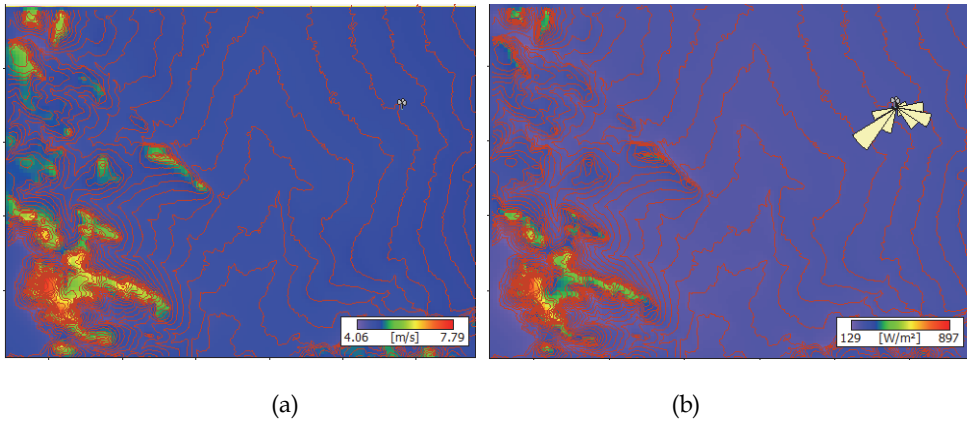

Fig. 12. Wind resource maps for (a) wind speed, and (b) power density at the UAA-UAZ station with all data captured with the WAsP package

From Fig. 12 it can be noted that the wind speed data obtained in this zone fluctuates between 4.06 and 7.79 m/s whereas the power density ranges from 129 and 897 W/m²; thus pointing out that using wind power here is a viable proposition.

6. Conclusions

This work focuses on the use of scientific findings and predefined coefficients for calculating the wind speed at different heights. Moreover, these findings must be pondered carefully because -as this work demonstrates- these coefficients are heavily dependent on the relevant land features.

Since the wind speed undergoes repeated changes and the roughness and friction coefficients also change in line with the landscape features, the time of the day, the temperature, height, wind direction, etc. it follows that the reading results (when extrapolating such wind speed data for a specific reference height) should be pondered carefully and taken with a pinch of salt.

This assumption is further enhanced by the basic hard facts that whenever we use a single equation or we have not identified the prevailing parameters on the site where the measuring instrument are placed, we could easily end up with misleading values or be far from their true values. Needless to say these wrong readings and assumptions will lead us to wrong estimates of energy obtained from the wind in a specific point, and thus it will impact in the wind energy resource assessment in a region.

The formulas and scientific findings can be used as initial estimates of the wind potential to be had at the desired altitudes. Such initial estimates do lead us to consider the necessity of an international standard to be applied and coupled with the necessary exceptions in each case. In real life and to sum up, there is no better substitute to actual site measurements.

This sort of surveys and analytical work are the initial steps prior to mounting the masts and towers fitted with either precision measuring instruments or wind generators. Indeed an analysis of this kind would help to save money and time that otherwise - i.e. in the absence of the appropriate methodology - would be totally wasted.

7. Acknowledgments

Our word of thanks goes to J. A. Serrano-García, D. E. Muciño-Morales for his significant contributions to this work. A significant fraction of this work was produced on the basis of monitoring station readings undertaken by the following institutions: IIE, INIFAP and UNAM. Their contribution is gratefully acknowledged. F. Bañuelos-Ruedas wishes to express his gratitude to the “Programa de Mejoramiento del Profesorado (PROMEP)” and to the UAZ for their support while this work was being compiled. Dr. Angeles-Camacho wishes to convey his gratitude for the support provided by DGAPA-UNAM under the project IN11510-2. Dr. Rios-Marcuello wishes to convey his gratitude for the support provided by the PUC of Chile.

8. References

- Bansal, R.; Bati, T.S. & Kothari, D.P. (2002). On Some of the Design Aspects of Wind Energy Conversion Systems. *Energy Conversion and Management* . Vol. 43, N° 16, pp. 2175–2187, November 2002.
- Borja M.A.; Gonzalez, R.; Mejía, F.; Hacuz, J.M.; Medrano, M.C.; & Saldaña, R. (1998). *Estado del Arte y Tendencias de la Tecnología Eoloeléctrica*. (In spanish) Instituto de Investigaciones Eléctricas, IIE/UNAM, ISBN 968-36-7433-X, México.
- Camblong, D. (2003). *Minimización de Impacto de las Perturbaciones de Origen Eólico en la Generación por Aeroturbinas de Velocidad Variable*. PhD Thesis. Mondragón Unibertsitatea, Spain.
- Danish Wind Industry Association. (2003). *Wind Energy Reference Manual*. Accessed Feb 2011, Available from: <http://guidedtour.windpower.org/en/stat/units.htm>.
- Escudero, J. (2004). *Manual de energía eólica*. (In spanish) Mundi prensa, ISBN 84-8476-165-7, Barcelona Spain.
- Farrugia, R.N.(2003).The wind shear exponent in a Mediterranean island climate. *Renewable Energy*. Vol. 28, N°. 4, pp. 647-653, April 2003.
- Fernández, P. *Energía Eólica*. Cantabria University. <http://www.termica.webhop.info/>; accessed March 2008.
- IIE. *Información Anemométrica de la Estación Cieneguillas, Zacatecas. 2005-2006*. Accessed May 2008. Available from: <http://planeolico.iie.org.mx>.
- Jaramillo, O.A. & Borja, M.A. (2004). Wind Speed Analysis in La Ventosa, Mexico: a Bimodal Probability Distribution Case. *Renewable Energy*. Vol 29, N° 10, , pp. 1613-1630, August 2004.
- Johnson, G.L. *Wind Energy Systems*. (December of 2006) Electronic Edition. <http://www.eece.ksu.edu/~gjohnson/Windbook.pdf>. Accessed May 2010.
- Masters, G.M. (2004). *Renewable and Efficient Electric Power Systems*. John Wiley and Sons, ISBN 0471280607, USA.
- Medina, G. (2007) *Reporte Agrometereológico Agosto de 2005-julio de 2006; Boletines informativos No. 15 al 26 INIFAP*. Centro de Investigación Regional Norte Centro, Campo Experimental Zacatecas. México.
- Patel, M.R. (2006). *Wind and solar power systems: design analysis, and operation*. 2nd ed. CRC Press, ISBN 0849315700, Florida (USA)
- Rehman, S. (2003) Wind shear coefficients and their effect on energy production. *Renewable Energy* 2007 Vol. 32, N° 5, pp. 738-74, April 2007.

- Sisterson, D.L.; Hicks, B.B.; Coulter, R.L. & Wesely, M.L. (1983). Difficulties in Using Power Laws for Wind Energy Assessment. *Solar Energy*; Vol. 31, N° 2, pp. 201-204.
- Torres, C.J. (2007) *Generación de Energía Eólica en el Estado de Zacatecas*. Comisión Nacional del Agua, Dirección Local Zacatecas. Ponencia en la Semana Internacional de Energía Fotovoltaica (Taller de Medición y Mapeo del Recurso Solar). June 2007.
- UNAM. *Proyecto CUenergía/1/17: "Diagnóstico del Potencial Eólico de Ciudad Universitaria del Macroproyecto "La Ciudad Universitaria y la Energía"*. Accessed December 2008. Available from: http://vesta.fi-b.unam.mx/cu_1_17/index.html.

Wind Energy Assessment of the Sidi Daoud Wind Farm - Tunisia

F. Ben Amar^{1,2} and M. Elamouri¹

¹*Preparatory Institute for Engineering Studies of Sfax*

²*Network and Machines Electric Research Unit, INSAT, Tunisia*

1. Introduction

In a world increasingly conscious of the degrading state of its environment and with the surge of the oil prices, renewable energies have found a choice place in the energy supply strategies of a great number of countries.

In fact, the growing interest in clean and durable energies in general, and in the wind energy in particular, is more than one society phenomenon. It presents today a true stake to which the energy supply security and the reduction of the toxic emissions are closely related. That's why, the contribution of the backers for the mobilization of the necessary financial and technical resources is a guarantee to support the efforts deployed by our countries in order to control the advanced technologies in this domain.

The African continent disposes of an important potential in renewable energies notably the hydraulics, the solar, the wind, the biogas and the geothermal. However, this potential remains strongly under exploited because of a certain number of obstacles related to the high cost of investment for these systems, the absence of competences and skilled human resources, the limit of the regional co-operation in this domain, the lack of maintenance structures and the absence of information and reliable data on the energy consumptions.

In Tunisia, the development that the country's economy has known for these last years with its positive repercussions on the social plan as well as on the living standard has contributed to the acceleration of the energy consumption rhythm, which on average has increased by 4% per year, thus exceeding the development rate of the hydrocarbons production. Indeed, since 2001, Tunisia has become an importer of primary energy (Fig. 1) [1-4].

In the electricity production sector, the Tunisian Company of Electricity and Gas (STEG) has engaged in a diversification of its production park mainly composed of conventional units (vapor thermic, gas turbine and combined cycle), through a progressive recourse to the production projects starting from renewable energies (hydraulic and wind turbines), in spite of their investment cost still high on a worldwide scale (Figs. 2 and 3) [1-4].

The wind power in Tunisia is considered, in the electricity production sector, as a vector carrying in the medium term in contribution to the energy balance improvement and equally to the fight against the climate change. In fact, it is proved that Tunisia is endowed with good wind energy potentials, hardly exploited so far. Moreover, this wind energy currently arouses a great interest not only on behalf of the authorities but also of the private

sector. An effort has been made in order to adapt the legal and institutional framework to this orientation [1-4].

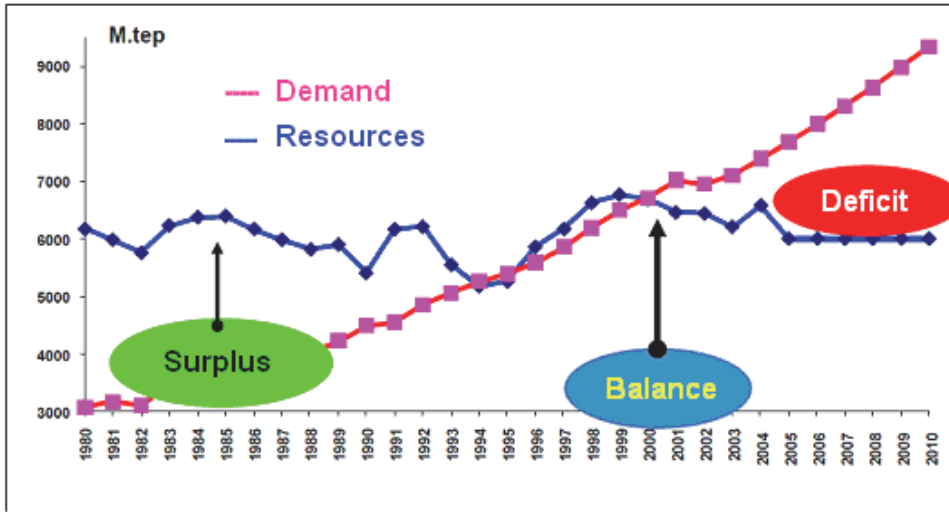

Fig. 1. Energy resources and demand in Tunisia.

Currently, the use of the wind energy in Tunisia and, consequently, the installation of wind farms have become unavoidable realities, due to the environmental problems posed by the traditional energy sources and of the aerogenerators technological progress. In fact, in order to meet the country's energy needs in the best economic conditions, of quality and respect of the environment as well as the users' safety, the STEG has already established its first wind park in Sidi Daoud in the area of the Cap Bon, in the North-East of the country (Fig. 4). This power station currently comprises 70 wind turbines of an installed power generation capacity of 53.6 MW, which corresponds to approximately 1 % of the national production park (Table 1). It has been accomplished in three stages [1-4]:

The first section of a power capacity of 10.56 MW, created in 2000, incorporates 32 aerogenerators (Made AE-32) with a asynchronous motor, having the unit nominal power of 330 kW. The second section of power capacity of 8.72 MW, created in 2003, comprises 12 aerogenerators: one wind turbine Made AE-52 with a synchronous motor of 800 kW and 11 wind turbines with asynchronous motor of which one machine Made AE-61 of 1.3MW capacity and 10 machines Made AE-46, each of them with a capacity of 660kW. The third section of power capacity of 34.32 MW, created in 2009, comprises 26 powerful wind turbines (MADE AE-61).

The wind energy station, the object of this study, with these 3 sections is located approximately 5 km of the coastal village of Sidi Daoud (800 inhabitants approximately). It is a sufficiently windy site, able to receive several wind turbines, far from the buildings and the obstacles and close to the electrical supply network (Fig. 5) [1-4].

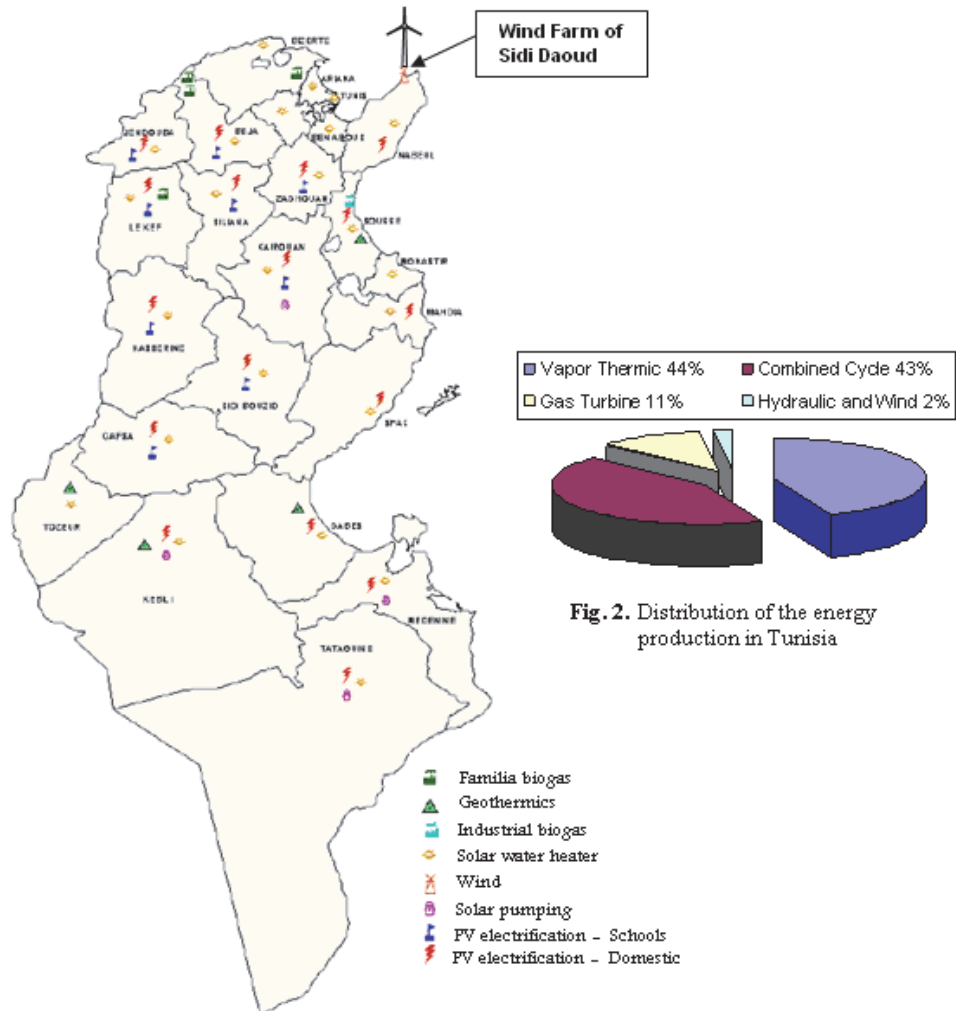

Fig. 2. Distribution of the energy production in Tunisia

Fig. 3. Distribution of renewable energy used in Tunisia.

Aerogenerator MADE	Generator type	Nominal power kW	Height (m)	Number	Section
• AE-32	Asynchronous	330	30	32	First
• AE-46	Asynchronous	660	45	10	Second
AE-52	Synchronous	800	50	1	"
AE-61	Asynchronous	1320	60	1	"
• AE-61	Asynchronous	1320	60	26	Third

Table 1. Aerogenerators of the Sidi-Daoud wind farm.

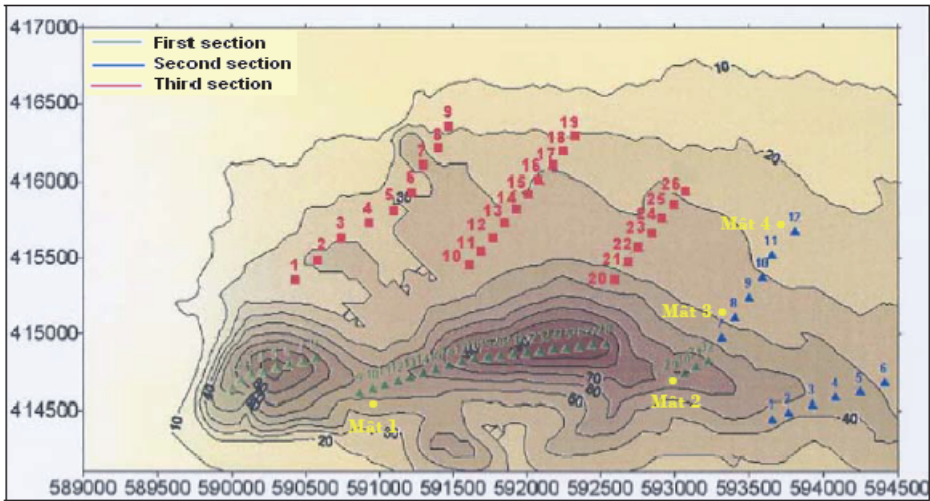

Fig. 4. Wind turbines installation of the Sidi Daoud wind farm - Tunisia.

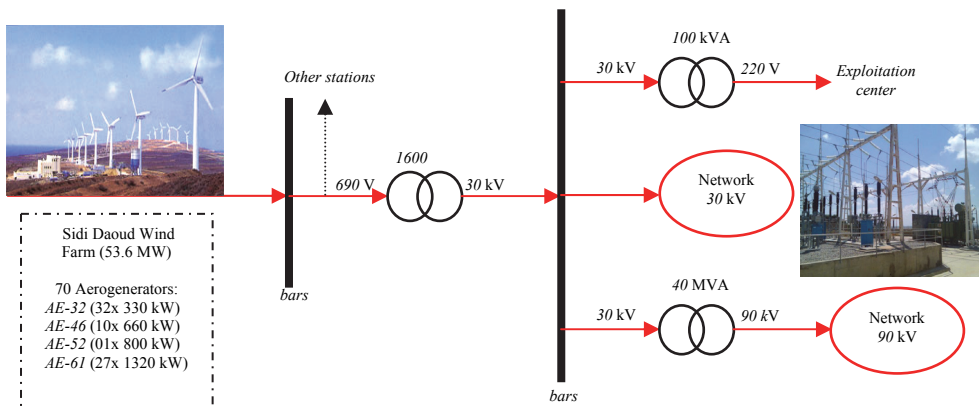

Fig. 5. Wind farm and electrical network of Sidi Daoud.

The objectives of this study are:

- The evaluation of the wind annual characteristics (distribution, direction, characteristic speeds and wind potential) of Sidi Daoud site by the meteorological method and the Weibull and Rayleigh analytical methods [5-21]. The data treated in this study, during four years period (2004-2007), are the measurements recorded in four places of the site (masts 1, 2, 3 and 4) at altitudes which correspond to the heights of the aerogenerators hubs (30, 45, 50 and 60 m above ground level). To evaluate statistically the performances of the Weibull and Rayleigh analytical distributions compared to the experimental distribution, we calculate the statistical parameters analysis for the wind speed and the power density distributions (The determination coefficient R^2 , the chi-square coefficient χ^2 and the root mean square error (*RMSE*)) [5-12].
- The modeling of the vertical profile of the wind speed in the measurement place mast 4 by the power and logarithmic laws, in order to know the evolution the wind speed at altitudes representing an energy interest [22-27]. A close attention is paid to the study of the influence height on the wind characteristics (mean speed and power density) by using the Rayleigh distribution.
- The determination of the energetic performances of the four aerogenerators with horizontal axis MADE AE-32, AE-46, AE-52 and AE-61 installed in site. From its characteristic curves, we study the aerodynamic and energy efficiency in terms of the wind speed, the use factor and the availability rate of each type of aerogenerator, installed with the various masts, and the whole wind farm [28-35].

2. Adjustment methods of the meteorological data

During the evaluation of the energetic performance of a wind system, it is essential to study the characteristics of the two elements: the site and the aerogenerator.

The object of the study of the site is to evaluate the following characteristics [5-21]:

- Mean speed ;
- Most energetic speed ;
- Most frequent speed ;
- Occurrence frequency ;
- Power density ;
- Available energy ;
- Duration of wind availability ;
- Shear coefficient.

The study of the aerogenerator makes it possible to define [28-35]:

- Usable energy ;
- Recoverable energy ;
- Power coefficient ;
- Mean efficiency ;
- Use factor ;
- Availability rate.

The used calculation methods [5-12]:

- Meteorological experimental method ;
- Weibull and Rayleigh distribution analytical methods.

From the tables of cumulated frequency of the classified wind speeds, the wind characteristics of the site are given by the following table 2:

The standard deviation enables to study the dispersion of wind speeds measurements around the mean speed. Indeed, if this standard deviation is weak, the values of measurements are regrouped around the average; if it is significant, they are very dispersed. The annual available energy of the wind in the site per unit area is given by the following relation:

$$E_d = 8,76 \cdot P_d \quad (1)$$

Wind characteristics	Meteorological method	Weibull method	Rayleigh method
Cumulated frequency	Tableau de l'I.N.M.	$F(V) = \int_V^{+\infty} f(V) \cdot dV = \exp \left[-\left(\frac{V}{A}\right)^k \right]$	$F(V) = \exp \left[-\frac{\pi}{4} \left(\frac{V}{V_m}\right)^2 \right]$
Occurrence frequency	$f(V) = F(V) - F(V+1)$	$f(V) = \frac{K}{A} \left(\frac{V}{A}\right)^{K-1} \exp \left[-\left(\frac{V}{A}\right)^K \right]$	$f(V) = \frac{\pi}{2} \left(\frac{V}{V_m}\right) \exp \left[-\frac{\pi}{4} \left(\frac{V}{V_m}\right)^2 \right]$
Mean speed	$V_m = \sum_{i=1}^n V_i f(V_i)$	$V_m = A \cdot \Gamma \left(1 + \frac{1}{k} \right)$	$V_m = \int_0^{+\infty} V \cdot f(V) \cdot dV$
Most frequent speed	$V_f = V [f(V)_{\max}]$	$V_f = A \cdot \left(1 + \frac{1}{k} \right)^{1/k}$	$V_f = \sqrt{\frac{2}{\pi}} \cdot V_m$
Most energetic speed	$V_e = V [P_d(V)_{\max}]$	$V_e = A \cdot \left(1 + \frac{2}{k} \right)^{1/k}$	$V_e = \sqrt{\frac{8}{\pi}} \cdot V_m$
Power Density	$P_d = \frac{1}{2} \cdot \frac{16}{27} \cdot \rho \cdot \sum_{i=1}^n V_i^3 f(V_i)$	$P_d = \frac{1}{2} \cdot \frac{16}{27} \cdot \rho \cdot A^3 \cdot \Gamma \left(1 + \frac{3}{k} \right)$	$P_d = \frac{3}{\pi} \cdot \rho \cdot V_m^3$
Standard deviation	$\sigma = \left[\sum_{i=1}^n (V_i - V_m)^2 f(V_i) \right]^{1/2}$	$\sigma = A^2 \left[\Gamma \left(1 + \frac{2}{k} \right) - \Gamma^2 \left(1 + \frac{1}{k} \right) \right]$	$\sigma = V_m^2 \left(\frac{4}{\pi} - 1 \right)$

Table 2. Evaluation methodologies of the wind characteristics.

3. Characterization of the site and evaluation of the wind potential

3.1 Sidi Daoud site relief

The establishment site of this wind station is located between the Mediterranean coasts in the north, of the villages of Sidi Daoud, Ghorman and of the forest dar Chichou in the south and the mountains of El Haouaria in the west coast. It has a mountainous relief, slightly lengthened according to the East-West direction. The vegetation in the neighborhoods of the site is practically uniform and it is composed of trees and shrubs of small sizes. Its geographical coordinates are of 37°02 ' for latitude and of 10°56 ' for longitude. The total

area used for the establishment of the power station is approximately 9 ha and extends on 3.5km from the coast (Fig. 6). It is a sufficiently windy site, able to receive several wind turbines, far from the buildings and the obstacles and close to the electrical supply network [1-4].

The aerogenerators of the first and the second section are established on the summits of the two mountains "Djebel El Hammam " and " Djebel Ghormane" whose altitude is respectively 50 and 100 m above sea level. The aerogenerators of the third section are located at the bottom of these two hills and about a hundred meters from the marine coasts.

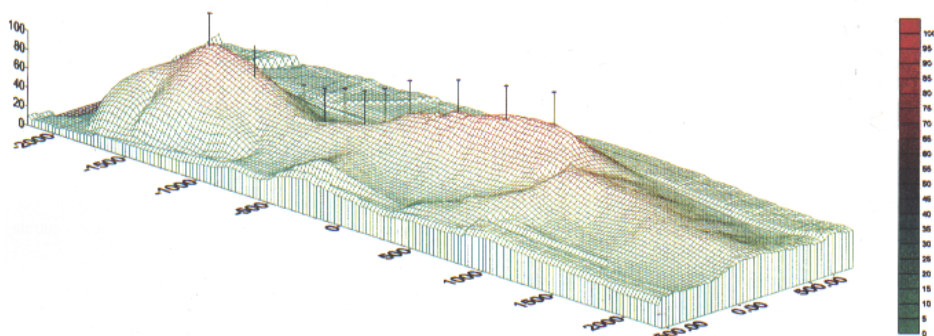

Fig. 6. Sidi Daoud site relief.

The meteorological data of the Sidi Daoud site used in this study were measured by the technical service of the wind farm during four years (2004–2007). The data relating to the direction and the wind speed were taken by four measurement masts at altitudes which correspond to the heights of the aerogenerators hubs (30, 45, 50 and 60 m above ground level) (Table 3).

Mast	1	2	3	4
Altitude (m)	68	75.3	40.42	22.78
Height sensor (m)	30	30	45 and 50	45 and 60

Table 3. Characteristics of the four measurement masts.

3.2 Wind roses

The wind rose is a spatial representation of the variation of the wind direction for such a site. It illustrates the direction of the dominant winds on a site and enables to plan the wind turbines installation in order to minimize the wake effect caused by nearby obstacles [5-12].

Fig. 7 represents the wind roses with 36 directions for the various masts. We note the importance of the wind coming from the West and South-East sectors and the wind's non-negligible existence from the North-West sector. In addition, the calm wind persists from both the north-east and south sectors.

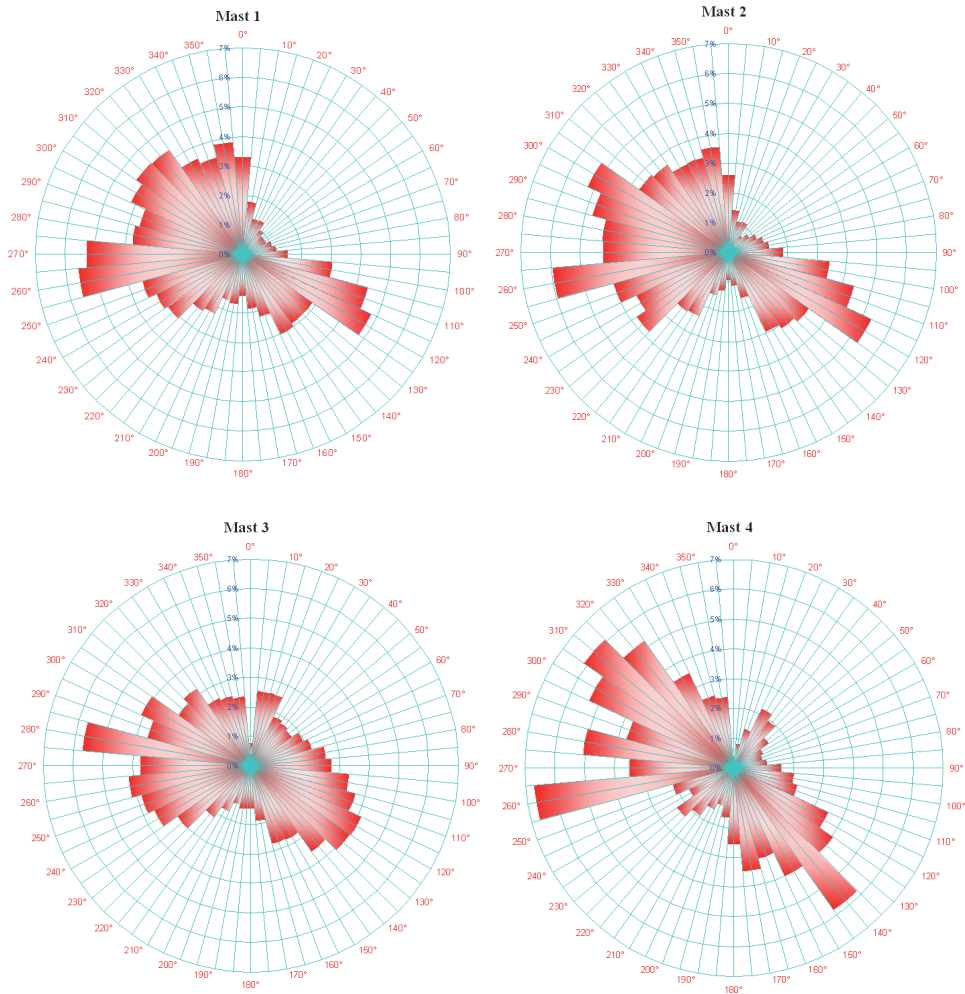

Fig. 7. Wind roses for the various measurement masts.

3.3 Wind characteristics: speeds and wind energy estimation

The statistical processing of the measured data has made it possible to determine the histograms and their adjustments by the meteorological method and the Weibull and Rayleigh methods, for various masts and heights, whose characteristic elements are:

- The analysis of table 4 shows that the wind characteristics (speeds and energy at the height 30 m) of mast 1 are better than those of mast 2. Indeed, the wind potential increased by 14% had with the increase the mean wind speed of 3.3% and the most energetic speed of 10%. The parameter k of the Weibull law, which characterizes the frequency distribution form, is about 1.9; whereas the parameter A , which determines the quality of the wind, is better with mast 1 (Figs. 8a and 8b).

- The wind characteristics at the height 45 m of mast 4 are slightly superior to those of mast 3 (Table 5). Indeed, the mean speed passes from 6.31m/s (mast 3) to 6.41 m/s (mast 4), which allows an energy profit of 5.6%. The most frequent and the most energetic speeds are respectively 5 m/s and 11 m/s for the two masts.
- For Mast 3, the passage of the height 45 m to 50 m allows a gain of 2.5% on the mean speed and 5.73% on the power density.
- For Mast 4, the passage of the height 45 m to 60 m allows a gain of 6.4% on the mean speed, 9% on most energetic speed and 20.12% on the power density.
- For masts 3 and 4, the parameter k of the Weibull law is about 2 for the various heights, whereas parameter A believes with the height. The distributions of the frequency classified speeds calculated by the two laws are equivalent; which seems normal to us because the form factor k is almost equal to 2 (Figs. 8c, 8d, 8e and 8f).
- The standard deviation σ is weak enough, which shows that the measurements are centered on the average (Tables 4 and 5).

Method	Mast 1 - 30 m			Mast 2 - 30 m		
	M	W	R	M	W	R
V_m (m/s)	6.59	6.68	6.59	6.38	6.45	6.38
V_f (m/s)	5	4.97	5.26	5	4.89	5.09
V_e (m/s)	11	11.13	10.51	10	10.62	10.18
E (kWh/m ² /an)	1921.61	1951.38	1737.17	1689.79	1719.9	1578
P (W/m ²)	219.36	222.76	198.31	192.90	196.34	180.14
A (m/s)		7.52035			7.26489	
k		1.86065			1.89609	
σ (m/s)	3.72887	3.72573	3.44427	3.53762	3.53601	3.33568

Table 4. Wind characteristics of the Sidi Daoud site calculated at the masts 1and 2.

Method	Mast 3 - 45 m			Mast 3 - 50m			Mast 4 - 45 m			Mast 4 - 60 m		
	M	W	R	M	W	R	M	W	R	M	W	R
V_m	6.31	6.40	6.31	6.47	6.59	6.47	6.42	6.54	6.42	6.83	6.91	6.83
V_f	5	5.12	5.04	5	5.36	5.16	5	5.19	5.12	5	5.47	5.45
V_e	11	10.201	10.071	11	10.38	10.32	11	10.46	10.24	12	11.08	10.89
E	1584.6	1588.9	1526.8	1675.4	1698.9	1644.7	1676.6	1704.4	1606.7	2013.8	2020.1	1932.3
P	180.89	181.38	174.29	191.25	193.94	187.75	191.39	194.57	183.41	229.89	230.61	220.58
A		7.222			7.440			7.374			7.794	
k		2.004			2.048			1.990			1.982	
σ	3.388	3.339	3.299	3.405	3.372	3.382	3.447	3.432	3.356	3.685	3.640	3.568

Table 5. Wind characteristics of the Sidi Daoud site calculated at the masts 3 and 4.

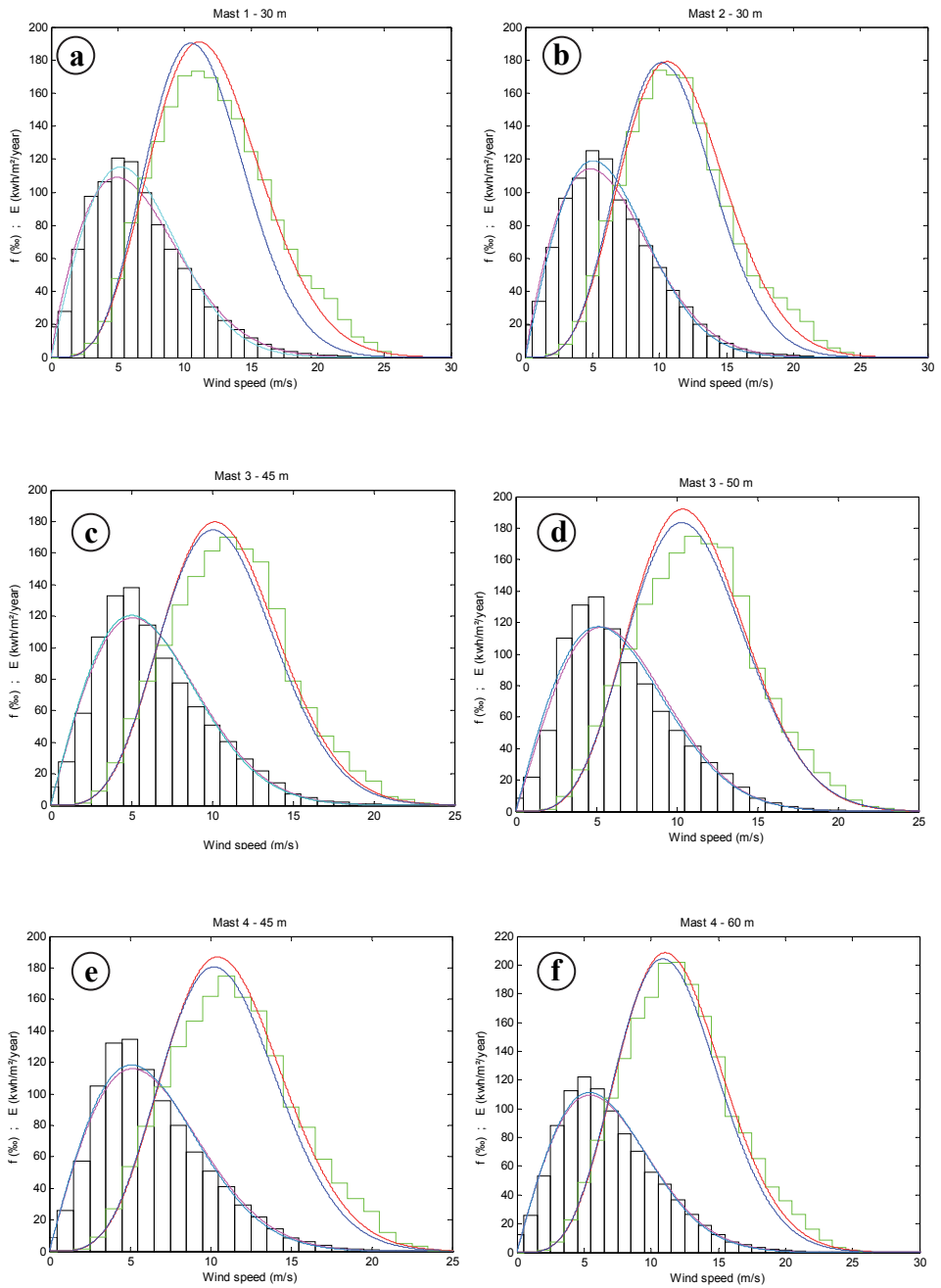

Fig. 8. Annual distributions of the wind speed and the available energy for the period 2004-2007.

These results prove that the Sidi Daoud site conceals a strong wind potential. Despite the complex relief of the site, the annual wind potential calculated at the various masts for the same height is almost constant, which shows the good stability of the wind resource of the Sidi Daoud site.

3.4 Statistical analysis parameters of Weibull and Rayleigh distributions

The determination coefficient R^2 (R is the correlation coefficient), the chi-square coefficient (χ^2) and the root mean square error ($RMSE$) analysis are statistically calculated to evaluate the performances of Weibull and Rayleigh models. Consequently, a better distribution has the highest value of R^2 and the lowest values of $RMSE$ and χ^2 [5-21].

The R^2 gives the effectiveness of the adjustment model. It is much better than its value being nearer to 1. It is calculated as follows:

$$R^2 = \frac{\sum_{i=1}^n (y_i - y_m)^2 - \sum_{i=1}^n (y_{ic} - y_i)^2}{\sum_{i=1}^n (y_i - y_m)^2} \quad (2)$$

The χ^2 is employed to determine the adjustment quality. At low values of χ^2 , the better adjustment quality is obtained. It is given by the following relation:

$$\chi^2 = \sum_{i=1}^n \frac{(y_i - y_{ic})^2}{y_i} \quad (3)$$

The $RMSE$ also gives the difference between computed and experimental values. Its minimal value tends toward zero. It is defined by the following expression:

$$RMSE = \left[\frac{1}{n} \sum_{i=1}^n (y_i - y_{ic})^2 \right]^{1/2} \quad (4)$$

The values of these parameters are given in table 6.

The comparison of the meteorological distribution (wind speed frequency and power density) with the Weibull and Rayleigh approximations shows that the latter two models present a better adjustment. Indeed, for these two models and for the four measurement masts (Table 6):

- The determination coefficient R^2 is very near to the unit.
- The $RMSE$ is very weak and does not exceed 0.95% for the adjustment of the wind frequency distribution and lower than 2 for the power density distribution.
- The chi-square coefficient χ^2 is also low and does not exceed 4% for the adjustment of the wind distribution and it varies from 2.7 to the 16.5 for the power density distribution.

It is noticed that the two adjustment models are equivalent for masts 3 and 4; which seems normal to us because the Rayleigh distribution is a particular case of Weibull (the form factor k of the studied site is about 2).

3.5 Availability duration of wind

Another parameter to be considered is the wind availability in the site. The curve speed-duration allows to determine the number of availability hours of the wind speed superior

or equal to a given threshold (Fig. 9); it is noticed that the wind blows at a speed higher than V_f (V_m and V_{er} , respectively) about 66% (48% and 11%, respectively) of annual time. Table 7 gives the durations and the minimum power densities for characteristic speeds (V_f , V_m and V_c) for various masts and at various heights.

Method		Occurrence frequency			Power density		
		R^2	χ^2	RMSE	R^2	χ^2	RMSE
Mast 1 30 m	W	0.977131	0.0321404	0.00617719	0.978849	3.63072	1.02
	R	0.982379	0.0314141	0.00542237	0.917189	16.5487	2.01828
Mast 2 30 m	W	0.981702	0.027062	0.00566918	0.988095	2.65463	0.754208
	R	0.985106	0.026041	0.00511471	0.973947	7.73753	1.11571
Mast 3 45 m	W	0.96582	0.0311569	0.00828543	0.973673	3.00107	1.12096
	R	0.968769	0.0317353	0.00791994	0.966837	4.14245	1.25812
Mast 3 50 m	W	0.956009	0.0365952	0.00942688	0.966365	3.65163	1.32168
	R	0.960885	0.0389296	0.00888907	0.972464	3.13961	1.19586
Mast 4 45 m	W	0.966577	0.0296976	0.00810549	0.973502	3.77	1.11853
	R	0.971301	0.0295496	0.00751076	0.965527	6.13694	1.2758
Mast 4 60m	W	0.980766	0.0230902	0.00563687	0.98726	2.74201	0.904176
	R	0.982598	0.0233729	0.00536173	0.979106	5.04789	1.15792

Table 6. Statistical analysis parameters for the wind speed distribution and the power density distribution relating to the various masts.

The curve power-duration also gives the hours' number when the site has a power density superior or equal to a given threshold (Fig. 10). For example, the site presents a power density higher than 0.5 kW/m² only from 12% (mast 3 at 45 m) to 16% (mast 4 at 60 m) of the annual time.

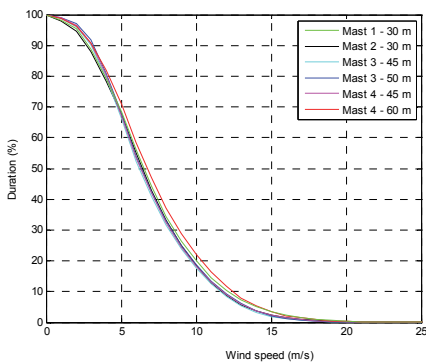

Fig. 9. Curve speed-duration of Sidi Daoud site.

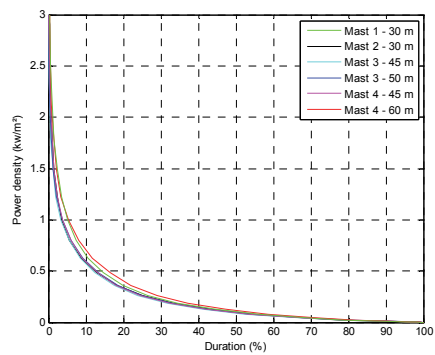

Fig. 10. Curve power-duration of Sidi Daoud site.

	Duration (%)			Minimum power density (W/m ²)		
	$V \geq V_m$	$V \geq V_f$	$V \geq V_e$	$V \geq V_m$	$V \geq V_f$	$V \geq V_e$
Mast 1 - 30 m	49.3	68.37	14.58	103.87	45.37	483.1
Mast 2 - 30 m	50.4	67.5	18.3	94.3	45.4	363.0
Mast 3 - 45 m	48.8	66.2	12.5	91.2	45.4	483.1
Mast 3 - 50 m	48.6	67.7	13.4	98.3	45.4	483.1
Mast 4 - 45 m	48.7	67.0	13.1	96.0	45.4	483.1
Mast 4 - 60 m	49.1	70.8	11.6	115.6	45.4	627.2

Table 7. Duration and minimum power density for the characteristic speeds.

4. Vertical extrapolation of the wind speed

4.1 Extrapolation laws

The precise evaluation of the wind power potential at a site place requires the knowledge of the wind speed at various heights. The standard height of measurement is generally of 10 m, but during a prospection of a site, in order to draw up a wind project, it is preferable to take measures at two or three levels for one period at least six months in order to know the evolution of the wind speed at altitudes representing an energy interest. The majority of work on the determination of the wind vertical profile in the surface boundary layer is based on the similarity theory of Monin-Obukov [22-23]. This theory was supplemented by studies which proposed extrapolation laws of the wind speed of a level H_1 on a level H_2 according to the variation of roughness classes.

In order to draw up a comparative study, two extrapolation laws are retained [22-27]:

- Logarithmic law ;
- Power law.

4.1.1 Logarithmic law

For neutral atmospheric conditions (i.e. when the turbulence forces are in balance), the Monin-Obukov expression, giving the wind speed profile, is written:

$$V(H) = \frac{u^*}{K} \cdot \ln\left(\frac{H}{Z_0}\right) \quad (5)$$

The ground roughness Z_0 and the corresponding friction speed u^* are then given starting from the wind speed measurements in two levels H_1 and H_2 by the following relations:

$$u^* = K \cdot \frac{V(H_2) - V(H_1)}{\ln\left(\frac{H_2}{H_1}\right)} \quad (6)$$

$$Z_0 = \exp\left[\ln(H_1) - \frac{K \cdot V(H_1)}{u^*}\right] \quad (7)$$

4.1.2 Power law

The extrapolation of the speed measured V_0 on a level H_0 towards speed $V(H)$ on a level H , is written:

$$V(H) = V_0 \cdot \left(\frac{H}{H_0} \right)^\alpha \tag{8}$$

α is the shear coefficient whose value depends on several factors like roughness, the topography and the atmosphere stability. It is given starting from the speed measurements in two levels H_1 and H_2 by the following relation:

$$\alpha = \frac{\text{Ln} \left(\frac{V_2}{V_1} \right)}{\text{Ln} \left(\frac{H_2}{H_1} \right)} \tag{9}$$

4.2 Results and comments

To identify the parameters of the site u^* , Z_0 and α , we applied the two extrapolation laws to mast 4 on the base of the annual mean speed (Table 8). It is noticed that these coefficients correspond to a rough ground with many hedges. Indeed, the Sidi Daoud site has a complex relief and very influenced by the sea (North and South-West sectors) and by the El Haouaria town (South-East and South-West sectors).

u^* (m/s)	Z_0 (m)	α
0.5701	0.4977	0.2152

Table 8. Extrapolation laws parameters calculated at mast 4.

The two extrapolation laws applied to the mast 4 have made it possible to trace the variation of the annual mean wind speed with height (Fig. 11). We note that the obtained results perfectly conform for all heights superior than 30 m. The passage of level 30 m at 100 m allows a gain on the mean speed of 30% and an energetic gain of 116%.

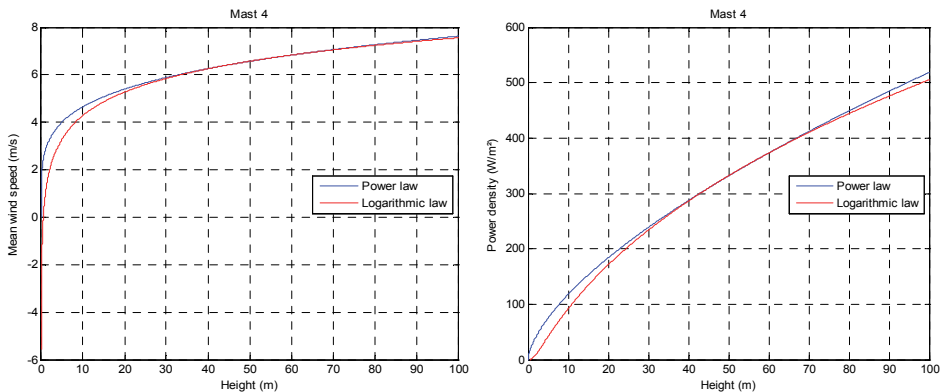

Fig. 11. Vertical profile of the wind speed and the power density.

5. Characterization of installed aerogenerators and evaluation of the energetic efficiencies

5.1 Aerodynamic efficiency of the aerogenerators

In this part, we are interested in the four types of aerogenerators MADE AE-32, AE-46, AE-52 and AE-61 with horizontal axis, installed in the Sidi Daoud wind farm.

According to the technical document of the manufacturer, the characteristics of the machines studied are given by Table 9.

Aerogenerators MADE	Regulation type	Generator speed	Nominal power (kW)	Multiplication coefficient	Rotor diameter (m)	Speeds (m/s)		
						Cut in V_d	nominal V_n	Cut out V_c
AE-32	Stall	1 speed	330	44.4	32	4	13	25
AE-46	Stall	2 speeds	660	59.5	46	3	15	"
AE-52	Pitch	variable	800	58.3	52	3	12	"
AE-61	Stall	2 speeds	1320	80.8	61	3	17	"

Table 9. Technical data of the aerogenerators.

Fig. 12. illustrates the variation of the electric power of each machine in function of the wind speed. The machines start from the same speed of 3 m/s (except the AE-32 which begins to 4 m/s) and must stop at 25 m/s. Beyond nominal speed, the power provided by synchronous machine AE-52 remains constant; on the other hand, that provided by asynchronous machines AE-32, AE-46 and AE-61 decreases slightly with the wind speed.

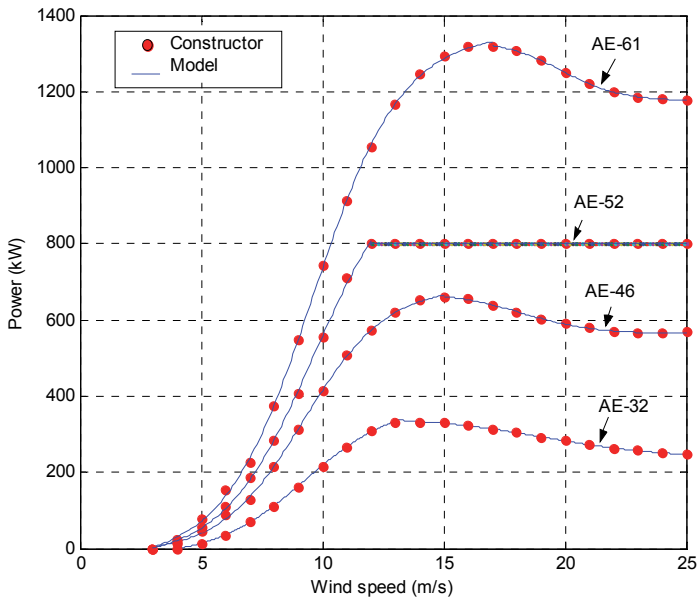

Fig. 12. Power curves of the aerogenerators.

The aerodynamic efficiency of the wind rotor defined by its power coefficient C_p is written:

$$C_p = \frac{P_s(V)}{\frac{1}{2} \cdot \rho \cdot S \cdot V^3 \cdot \mu_m \cdot \mu_g} \tag{10}$$

where μ_m and μ_g respectively represent the gearbox efficiency and the generator efficiency. This dimensionless parameter, which expresses the aerodynamic effectiveness of rotor of the various aerogenerators [20-21], is represented by Fig. 13. For such an aerogenerator, this coefficient is a function the wind speed wind, the chock angle and the rotational speed of rotor. The maximum theoretical value of C_p given by Betz limit is 59.3%.

For the four machines, this coefficient reaches its maximum at the optimal wind speed $V_{opt}=9$ m/s (Table 11). This maximum varies from 45.51% (AE-61) to 49.07% (AE-32). For low speeds, the curve of the power coefficient progresses quickly towards the optimum operating point. Beyond this point, we observe degradation slower of C_p towards a limiting value of the order 4% which corresponds at the cut out speed of the machine.

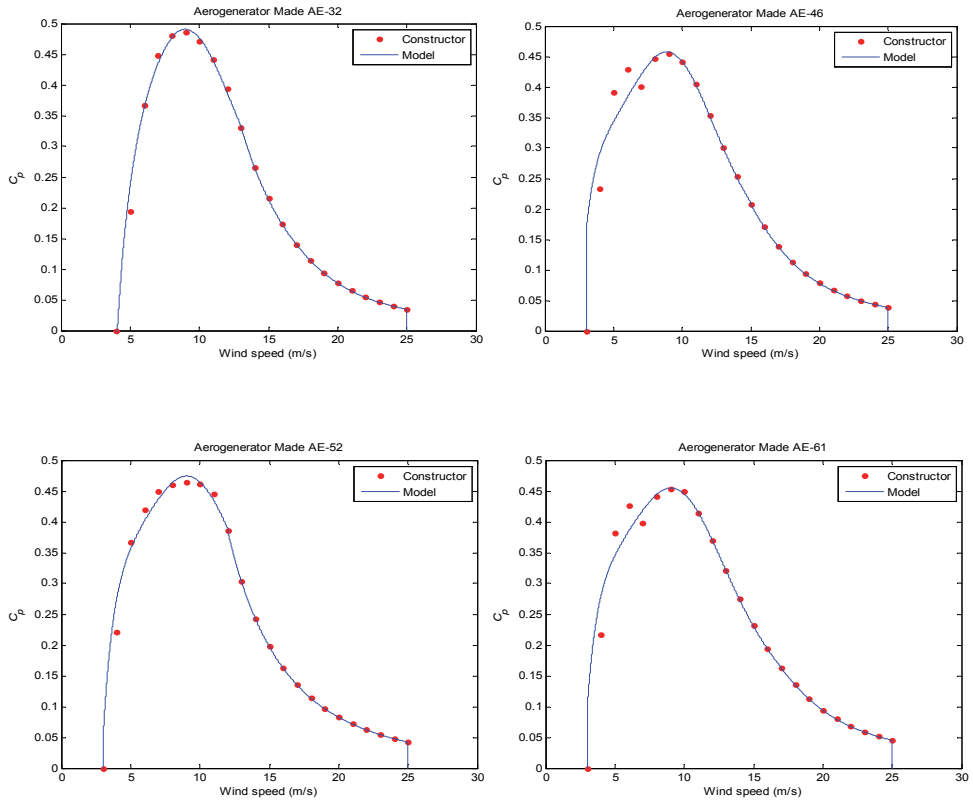

Fig. 13. Curves of aerodynamic efficiency $C_p=f(V)$ of the various aerogenerators.

In addition to the estimate of produced annual energy, it is interesting to know the annual time of the wind turbine production. Fig. 14 illustrates the site frequency-speed histograms and the machines reduced power curve. We observe that during 22 % (respectively 10%, 8% and 9.5%) of the annual time, the wind speed is insufficient to operate the wind turbine AE-32 (respectively AE-46, AE-52 and AE-61) and it blows sufficiently to obtain the full efficiency during 6 % (respectively 2%, 9% and 1.5%) of the annual time. The remaining time of value 72 % (respectively 88%, 83% and 89%), the efficiency varies with the wind speed. Also, we have plotted the power-duration curve of each aerogenerator indicating the time percentage when the wind turbine provides a power higher than a given threshold (Fig. 15). Thus, the machine AE-32 (respectively AE-46, AE-52 and AE-61) will produce its maximum power only for 526 h/year (respectively 175 h/year, 788 h/year and 131 h/year) of the annual time; which accounts for approximately 7.7% (respectively 2.2%, 9.8% and 1.7%) of its operating annual time. We notice that the four aerogenerators most of the time function below their nominal capacities.

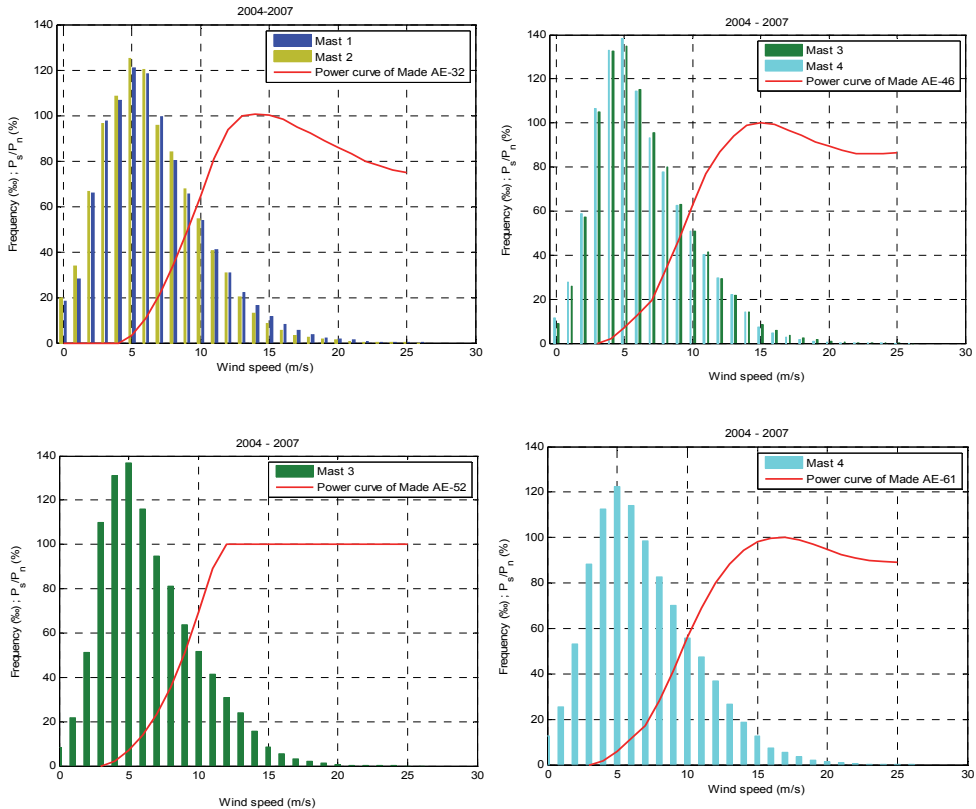

Fig. 14. Annual frequency-speed histograms of the site.

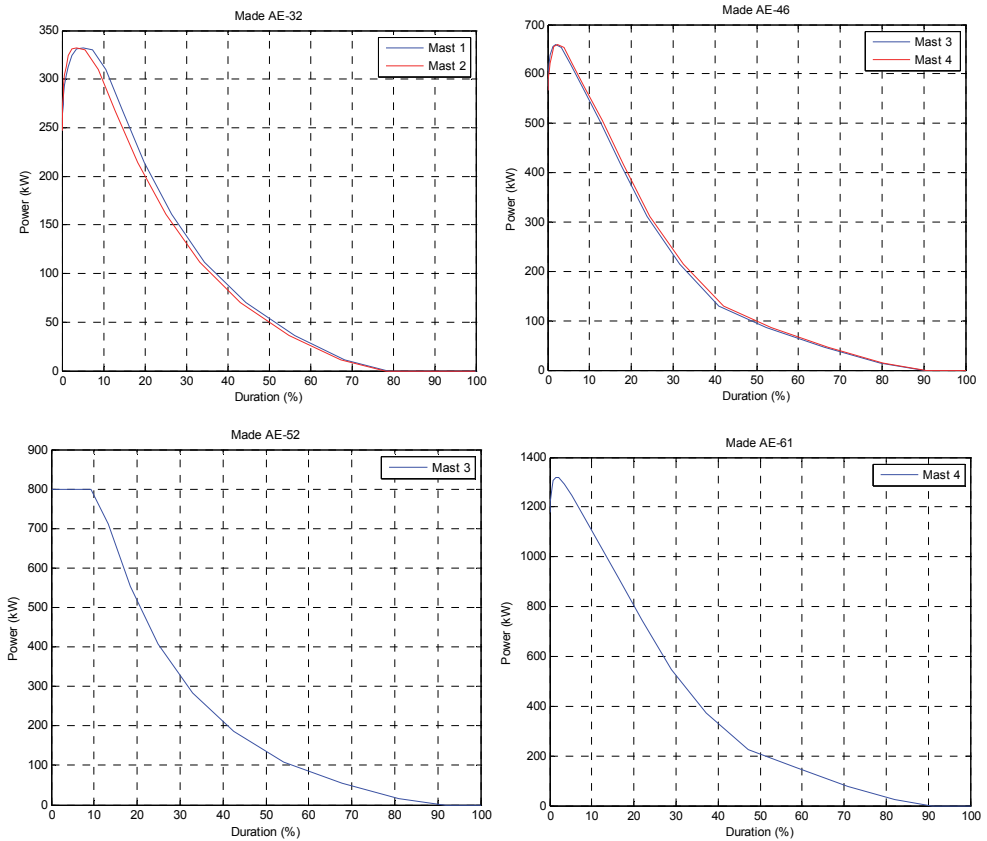

Fig. 15. Annual power-duration curves of the aerogenerators.

5.2 Annual energy produced by the various aerogenerators

The available energy really usable E_u that can be received by the aerogenerator is proportional to the cube of the wind speed and the wind distribution in the site [28-35].

Knowing the wind mode, this usable energy is given by the following expression:

$$E_u = \frac{1}{2} \cdot 8,76 \cdot \rho \cdot S \cdot \left(\sum_{i=d}^n (V_i)^3 f(V_i) + (V_n)^3 \sum_{i=n}^c f(V_i) \right) \quad (11)$$

where $S = \pi R^2$ is the rotor swept surface of radius R .

In the same way, recoverable energy E_r on the aerogenerator outlet (rotor+gearbox+generator) is given by the machine power curve and the wind statistical distribution.

$$E_r = 8,76 \cdot \left(\sum_{i=d}^c f(V_i) P_S(V_i) \right) \quad (12)$$

where $P_s(V_i)$ is the electric power on the aerogenerator outlet.

We notice that the calculation of recoverable energy by the Weibull and Rayleigh analytical methods necessitates of modeling the power curve $P_s(V)$ by an analytical expression. The Boltzman theoretical model allows reproducing this curve correctly. It is written as follows:

$$P_s(V) = \frac{A_1 - A_2}{1 + \exp\left(\frac{(V - V_0)}{\omega}\right)} + A_2 \tag{13}$$

The parameters V_0 , A_1 , A_2 and ω of each aerogenerator are identified by the software "Origin 5.0" and their optimal numerical values are determined by minimizing the quality criterion χ^2 (Table 10).

Aerogenerators	AE-32		AE-46		AE-52		AE-61	
Parameters	$3 \leq V \leq 13$	$13 \leq V \leq 25$	$3 \leq V \leq 15$	$15 \leq V \leq 25$	$3 \leq V \leq 12$	$12 \leq V \leq 25$	$3 \leq V \leq 17$	$17 \leq V \leq 25$
A_1	381.89	241.133	-13.38	672.75	-27.93	$P_s(V) = 800$ kW	-32.405	1334.8
A_2	-22.464	338.249	688.25	563.45	1045.5		1354.9	1175.2
V_0	9.3116	19.4191	9.2317	18.227	9.6543		9.6006	19.86
ω	-1.852	-2.136	1.6999	1.484	1.861		1.8287	1.221

Table 10. Boltzman theoretical model parameters of the power curve of each aerogenerator.

Fig. 16 represents the variation of annual energies (available, usable and recoverable) in function of the wind speed for the various masts and aerogenerators. We see that the maxima of the three energies curves pass approximately by the same wind speed, which shows the good adaptation of the aerogenerators to the Sidi Daoud site.

We notice that the annual wind power produced by each wind turbine represents approximately one-third of the total available energy in the site.

5.3 Energy efficiencies of the aerogenerators

Using the computed energies, the wind turbine mean efficiency relating to the available energy is estimated by the expression [28-35]:

$$\mu_d(V_i) = \frac{E_r(V_i)}{E_d(V_i)} = \frac{P_s(V_i)}{\frac{1}{2} \cdot \rho \cdot S \cdot V_i^3} \tag{14}$$

The wind turbine mean efficiency relating to usable energy can also be defined by the following expression:

$$\mu_u(V_i) = \frac{E_r(V_i)}{E_u(V_i)} = \begin{cases} \frac{P_s(V_i)}{\frac{1}{2} \cdot \rho \cdot S \cdot (V_i)^3} & \text{pour } V_d \leq V_i \leq V_n \\ \frac{P_s(V_i)}{\frac{1}{2} \cdot \rho \cdot S \cdot (V_n)^3} & \text{pour } V_n \leq V_i \leq V_c \end{cases} \tag{15}$$

These two ratios of energy represent the product of the mechanical efficiency (gearbox and generator) and the rotor aerodynamic efficiency.

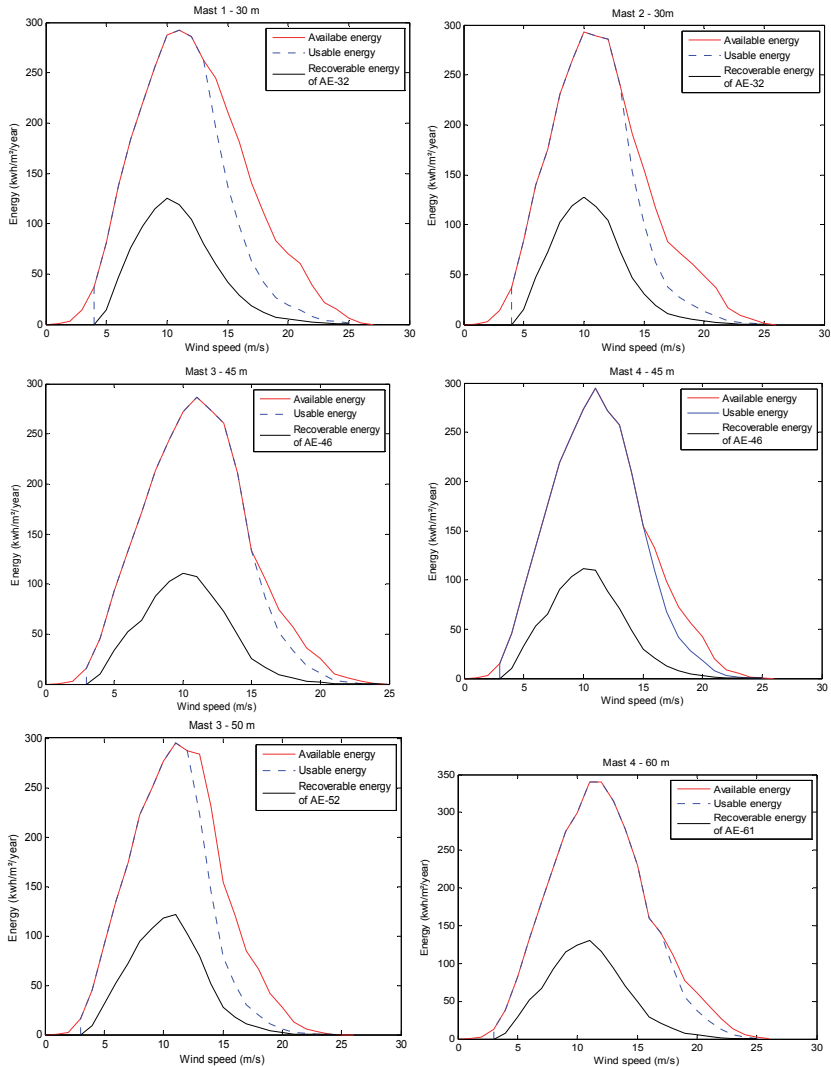

Fig. 16. Energies curves calculated by the meteorological method.

Fig. 17 represents the variation of these mean efficiencies as a function of the classified speed for the various aerogenerators. It is noted that the mean efficiencies pass by the same maximum μ_{max} for a wind speed of approximately 9 m/s. This maximum varies from 41.92 % (AE-61) to 44.8% (AE-32) (Table 11). It is significant to notice that this mean efficiency remains superior to 0.4 in the wind speed zone included between 6.8 m/s and 11.2 m/s for the AE-32, between 7.7 m/s and 10.25 m/s for the AE-46, between 6.5 m/s and 11.25 m/s for the AE-52 and between 7.8 m/s and 10.45 m/s for the AE-61.

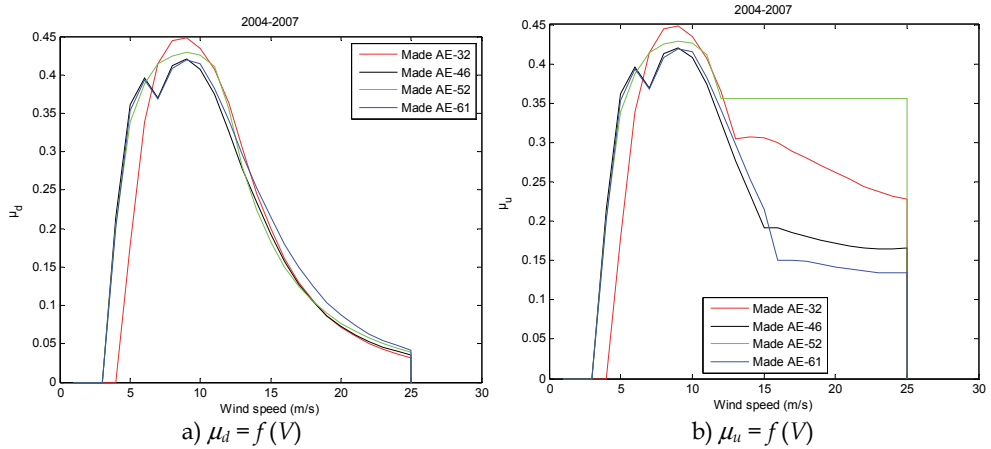

Fig. 17. Mean efficiencies curves of the aerogenerators calculated by the meteorological method.

Aerogenerators	C_{pmax} (%)	μ_{max} (%)	V_{opt} (m/s)
AE-32	49.07	44.83	9
AE-46	45.77	42.05	9
AE-52	47.44	42.92	9
AE-61	45.51	41.92	9

Table 11. Optimum operating point of wind turbines.

In addition, the annual mean efficiency of each wind turbine is defined by:

$$\mu = \frac{E_r}{E_d} \tag{16}$$

The numerical results obtained by the three methods are comparable and indicate that the annual mean efficiency remains higher than 30% for the various machines (Table 12). Consequently, the energy produced by each machine is important and reaches the 1/3 of the site available energy.

Aerogenerator	AE-32		AE-46		AE-52	AE-61
Mast	1	2	3	4	3	4
Meteorological	29.54	31.74	31.52	30.61	32.18	30.31
Weibull	30.53	32.10	32.45	31.73	34.63	31.09
Rayleigh	32.96	33.75	32.75	32.32	34.53	31.64

Table 12. Annual mean efficiency μ (in %) of each aerogenerator.

In practice, a maximum energy efficiency of wind turbine is ensured by an optimal aerodynamic efficiency of rotor. To optimize this efficiency, the control of the aerogenerator must be made so that the rotational rotor speed adapts to the site wind speed.

5.4 Use factor and availability rate

However, the wind turbine cannot function with full power all the time (maintenance, breakdowns, wind availability, etc.). To quantify the recovered power by each aerogenerator, it is interesting to calculate its annual use factor UF which is defined by the ratio of the produced electric power on the installed power [28-35]:

$$UF(\%) = 100 \cdot \frac{\sum_{i=d}^c f(V_i) P_s(V_i)}{P_n} \quad (17)$$

According to the relation (16), we note that this factor UF depends only on the wind frequency (at the nacelle height) for such an aerogenerator. Table 13 shows that the machine AE-52, which has the lowest nominal speed ($V_n=12\text{m/s}$), presents the best use factor.

Aerogenerator	AE-32		AE-46		AE-52	AE-61
Mast	1	2	3	4	3	4
Meteorological	26.65	25.18	24.23	24.90	27.58	26.04
Weibull	28.00	25.92	25.01	26.22	30.08	26.79
Rayleigh	26.90	24.99	23.70	25.19	29.04	26.11

Table 13. Annual use factor UF (in %) of each aerogenerator.

Based on the results of the annual energy recovered by each machine, we note that the use factor of the whole wind farm (70 aerogenerators of an installed power generation capacity of 53.6 MW) is about 25.87%; what shows that the maximum annual energy production of the wind power station is approximately 121.5 GWh/an.

To estimate the operation duration of an aerogenerator, we define the availability rate AF which depends on the machine characteristics and the wind potential in the site. For such a wind turbine having a cut in speed V_d and a cut out speed V_c , the availability rate AF is the probability P calculated by the following equation [28-35]:

$$AF(\%) = 100 \cdot P(V_d \leq V \leq V_c) = 100 \cdot [F(V_d) - F(V_c)] \quad (18)$$

In general, this factor rises when the difference ($V_c - V_d$) and the mean wind speed increase. The obtained values for the various aerogenerators are excellent (Table 14) and show that the production time exceeds 90% of annual time for machines AE-46, AE-52 and AE-61 and about 80% for the AE-32.

Aerogenerator	AE-32		AE-46		AE-52	AE-61
Mast	1	2	3	4	3	4
Meteorological	79.01	78.24	90.18	90.76	91.86	90.86
Weibull	73.41	82.94	92.66	92.81	93.44	93.47
Rayleigh	74.87	84.06	92.42	92.66	92.77	93.48

Table 14. Annual availability rate AF (in %) of each aerogenerator.

Consequently, to completely describe the energetic profitability of an aerogenerator, it is necessary to take account simultaneously of these four factors: the aerodynamic efficiency, the mean efficiency, the use factor and the availability rate.

6. Conclusion

This study has presented the development of the wind power use in Tunisia for the electricity production. The main contribution of this chapter is the energy performance evaluation of the first wind farm installed in Sidi Daoud - Tunisia, particularly the effectiveness of various aerogenerators (MADE AE-32, AE-45, AE-52 and AE-61) implanted on the site, by the meteorological experimental method and the Weibull and Rayleigh analytical methods.

The data treated in this study are the measurements recorded in four places (masts 1, 2, 3 and 4) of the site at altitudes which correspond to the heights of the aerogenerators hubs (30, 45, 50 and 60 m above ground level) (Tab. 2). These measurements are spread out over a four-year period (2004-2007).

The principal results of this study are:

Concerning the wind resource of the site,

- The Sidi Daoud site has an important and stable wind potential. Indeed, the power density calculated at the various heights (30, 45, 50 and 60 m) varies from 180 to 230 W/m^2 according to the measurement mast place. The mean speed also varies from 6.3 to 6.8 m/s. The dominant directions of the wind are the west and south-east sectors.
- The identified parameters of the two distribution functions (A , k and V_m) show that the two models are quasi-equivalent. Indeed, the values of the statistical analysis parameters (R^2 , $RMSE$ and χ^2) indicate a better adjustment of the meteorological data by the two models.
- The modeling of the wind vertical profile by the logarithmic and power laws is applied to the mast 4 place. The extrapolation of the height 30 to 100 m enables us to obtain a gain on the mean speed of 30% and a gain on the power density of 116%.

Concerning the aerogenerators performance,

- The maximum power coefficient C_{pmax} varies from 45.51% (AE-61) to 49.07% (AE-32) for the same optimal wind speed $V_{opt} = 9$ m/s.
- The annual mean efficiency remains superior to 30% for the various machines. Indeed, recoverable energy is important and it is about the 1/3 of the available energy in the site.
- The use factor UF varies from 23 to 28% according to the type and place of the aerogenerator. It is about 25.87% on average for the whole wind farm.
- The availability rate AF is excellent and exceeds 90% of annual time for aerogenerators AE-46, AE-52 and AE-61 and about 80% for the AE-32.
- The aerogenerator AE-52 presents the energetic performances higher than those of the other machines.

7. Nomenclature

V	Wind speed (m/s)
$F(V)$	Cumulated frequency
$f(V)$	Occurrence frequency
n	Number of wind-speed classes
V_m	Mean speed (m/s)
V_f	Most frequent speed (m/s)
V_e	Most energetic speed (m/s)
P_d	Power density at Betz limit (W/m^2)
E_d	Available energy at Betz limit ($kWh/m^2/year$)
E_u	Usable energy ($kWh/m^2/year$)
E_r	Recoverable energy ($kWh/m^2/year$)
P_s	Electric power on the aerogenerator outlet (W)
P_n	Nominal power of the aerogenerator (W)
$P_{d(M)}$	Mean power density calculated from the meteorological method (W/m^2)
$P_{d(W,R)}$	Mean power density calculated from the Weibull and Rayleigh functions (W/m^2)
μ_d	Mean efficiency relating to the available energy
μ_u	Mean efficiency relating to the usable energy
μ	Mean efficiency
μ_m	Gearbox efficiency (96%)
μ_g	Generator efficiency (96.2%)
u^*	Friction speed (m/s)
Z_0	Ground roughness (m)
a	Shear coefficient
H	Measurement height (m)
C_p	Power coefficient
UF	Use factor
AF	Availability rate
A	Paramètre d'échelle de Weibull (m/s)
k	Weibull scale factor
K	Von-Karman constant ($K=0.4$)
S	Rotor area (m^2)
ρ	Air density ($1.225 kg/m^3$)
$\sigma_{(M,W,R)}$	Standard deviation calculated from the meteorological, Weibull and Rayleigh methods (m/s)
R^2	Determination coefficient
χ^2	Chi-square coefficient
$RMSE$	Root mean square error
y_i	i th measured value
y_{ic}	i th calculated value
y_m	Mean value
Γ	Gamma function
M	Meteorological method
W	Weibull method
R	Rayleigh method

8. References

- [1] Agence Nationale des Energies Renouvelables (ANER). Etude Stratégique pour le développement des Energies Renouvelables en Tunisie. Rapport final, Alcor - Axenne, juillet 2003.
http://www.anme.nat.tn/sys_files/medias/documents/etudes/dvp_energies_renouvelables/1_-_Bilan_des_realisations.pdf
- [2] Ben Jannet Allal H. Energie et Ecodéveloppement en Tunisie. Report of Helio International,
[/http://www.helio-international.org/reports/pdfs/Tunisie-FR.pdf](http://www.helio-international.org/reports/pdfs/Tunisie-FR.pdf).
- [3] Société Tunisienne de l'Electricité et du Gaz (STEG). Projet Eolien de Sidi Daoud : Etude d'impact sur l'environnement de la 3ème tranche de la centrale éolienne. Gouvernerat de Nabeul, 31 Novembre 2009.
http://www.steg.com.tn/dwl/EIE_Centrale_Eolienne_Sidi_Daoud.pdf.
- [4] Société Tunisienne de l'Electricité et du Gaz (STEG). Réalisation d'une ligne électrique aérienne 90 KV/Sidi Daoud/Menzel Temime, ETUDE D'IMPACT SUR L'ENVIRONNEMENT. Gouvernerat de Nabeul, 31 Juillet 2009.
http://www.steg.com.tn/dwl/EIE_ligne_HT_Sidi_Daoud.pdf.
- [5] T. P. Chang, Estimation of wind energy potential using different probability density functions. *Applied Energy* 88 (2011) 1848-1856.
- [6] V. Lo Brano, A. Orioli, G. Ciulla, S. Culotta, Quality of wind speed fitting distributions for the urban area of Palermo, Italy. *Renewable Energy* 36 (2011) 1026-1039.
- [7] B. Safari, Modeling wind speed and wind power distributions in Rwanda. *Renewable and Sustainable Energy Reviews* 15 (2011) 925-935.
- [8] J. Zhou, E. Erdem, G. Li, J. Shi. Comprehensive evaluation of wind speed distribution models: A case study for North Dakota sites. *Energy Conversion and Management* 51 (2010) 1449-1458.
- [9] J.A. Carta, P. Ramirez, S. Velaiquez, A review of wind speed probability distributions used in wind energy analysis Case studies in the Canary Islands. *Renewable and Sustainable Energy Reviews* 13 (2009) 933-955.
- [10] Y.Q. Xiao, Q.S. Lia, Z.N. Li, Y.W. Chow, G.Q. Li, Probability distributions of extreme wind speed and its occurrence interval. *Engineering Structures* 28 (2006) 1173-1181.
- [11] M. Li, X. Li, On the probabilistic distribution of wind speeds: theoretical development and comparison with data. *Int. J. Exergy*, Vol. 1, No. 2, 2004.
- [12] Celik AN. A statistical analysis of wind power density based on the Weibull and Rayleigh models at the southern region of Turkey. *Renewable Energy* 29 (2003) 593-604.
- [13] S. Akpinar, E. K. Akpinar, Estimation of wind energy potential using finite mixture distribution models. *Energy Conversion and Management* 50 (2009) 877-884.
- [14] Elamouri M, Ben Amar F. Wind energy potential in Tunisia. *Renewable Energy* 33 (2008) 758-768.
- [15] Belu Radian, Koracin Darko. Wind characteristics and wind energy potential in western Nevada. *Renewable Energy* 34 (2009) 2246-2251.
- [16] Zhou W, Yang H, Fang Z. Wind power potential and characteristic analysis of the Pearl river delta region China. *Renewable Energy* 31 (2006) 739-753.
- [17] Jewer P, Iqbal MT, Khan MJ. Wind energy resource map of Labrador. *Renewable Energy* 30 (2005) 989-1004.

- [18] M. Li, X. Li, Investigation of wind characteristics and assessment of wind energy potential for Waterloo region, Canada, *Energy Conversion and Management* 46 (2005) 3014–3033.
- [19] Akpınar EK, Akpınar S. Determination of the wind energy potential for Maden-Elazığ, Turkey. *Energy Conversion Management* 45 (2004) 2901–2914.
- [20] J. Coriton : Energie éolienne et conversion en chaleur. Etude bibliographique. Centre Scientifique & Technique du Batiment (CSTB), Division climatologie, EN-CLI 82.9.R 1982.
- [21] Duchene-Marullaz PH, Sacre CH. Guide d'implantation des petites éoliennes. Centre Scientifique & Technique du Batiment (CSTB), Division climatologie, EN-CLI 84.4. L 1984.
- [22] Elamouri M, Ben Amar F, Trabelsi A. Vertical characterization of the wind mode and its effect on the wind farm profitability of Sidi Daoud - Tunisia. *Energy Conversion and Management* 52 (2011) 1539–1549.
- [23] Giannini L, Argentini S, Mastrantonio G, Rossini G. Estimation of flux parameters from sodar wind profiles. *Atmospheric environment* 31 (1997) 1307–1313.
- [24] Rehman S, Al-Abbadi NM. Wind shear coefficients and their effect on energy production. *Energy Conversion and Management* 46 (2005) 2578–2591.
- [25] Perez IA, Garcia MA, Sanchez ML, de Torre B. Analysis of height variations of sodar-derived wind speeds in Northern Spain. *J Wind Eng Ind Aerodynamics* 92 (2004) 875–894.
- [26] Farrugia RN. The wind shear exponent in a Mediterranean island climate. *Renewable Energy* 28 (2003) 647–653.
- [27] Hussain M. Dependence of power law index on surface wind speed. *Energy Conversion and Management* 43 (2002) 467–472.
- [28] F. Ben Amar, M. Elamouri, R. Dhifaoui : Energy assessment of the first wind farm section of Sidi Daoud, Tunisia. *Renewable Energy* 33 (2008) 2311–2321.
- [29] Chang TJ, Wu YT, Hsu HY, Chu CR, Liao CM. Assessment of wind characteristics and wind turbine characteristics in Taiwan. *Renewable Energy* 28 (2003) 851–871.
- [30] Acker TL, Williams SK, Duque EPN, Brummels G, Buechler J. Wind resource assessment in the state of Arizona: inventory capacity factor and cost. *Renewable Energy* 32 (2007) 1453–1466.
- [31] Abderrazzaq MH. Energy production assessment of small wind farms. *Renewable Energy* 29 (2004) 2261–2272.
- [32] E. Kavak Akpınar, S. Akpınar : An assessment on seasonal analysis of wind energy characteristics and wind turbine characteristics. *Energy Conversion and Management* 46 (2005) 1848–1867.
- [33] Johnson GL. Wind energy systems. Electronic Edition. December 10, 2001. Manhattan, KS.
- [34] Henderson-Sellers B. Plume rise modelling: the effects of including a wind shear and a variable surface roughness. *Ecological Modelling* 37 (1987) 269–286.
- [35] Cliff WC. The effect of generalized wind characteristics on annual power estimates from wind turbine generators. Report PNL-2436, 1977. US Department of Energy.

Wind Farms and Their Impact on the Environment

Vladimír Lapčík

*Institute of Environmental Engineering, Faculty of Mining and Geology
VSB – Technical University of Ostrava
Czech Republic*

1. Introduction

This chapter summarizes author's experience with environmental impact assessment in branch of wind farms. The introductory part of chapter describes history and development of wind power utilization world-wide and in the Czech Republic. Next part of chapter deals with technology of wind turbines and their development. The final part of chapter deals with experience with environmental impacts of wind farms and implementation of the environmental impact assessment process (pursuant to the Act No. 100/2001 Coll. on environmental impact assessment, as amended) in the field of wind power in the Czech Republic.

2. History and development of wind power utilization

2.1 Significance of wind energy as a renewable source

A direct impetus for the development of wind energetics in Europe was the energy crisis in 1973 caused by an embargo enforced by OPEC on the oil export into developed countries. Pressured by a sharp increase in the world-wide prices of oil, countries with own limited classical energy sources began to search for a possible utilization of renewable energy sources, including wind, in a wider scale. Denmark was the pioneer in the development of wind energetics in Europe as they started to construct the first wind farms at the end of the 1980s (Štekl et al., 1993).

Wind energetics uses inexhaustible kinetic energy of the wind, totally for free, and thus it is not subject to inflation. In this manner, it reduces the dependence on the import of raw materials for power generation, namely from regions characteristic for their political instability. The principle of inexhaustibility of the wind gains on importance when compared with the brown coal reserves in the Czech Republic (CR). Adhering to the territorial environmental limits set by 1991 government decree, between 2040 and 2050 the extraction of brown coal shall drop below the level of the coal fired power plant needs (Štekl, 2008).

Wind energetics is most environmentally friendly, which is currently extraordinarily important in the climate protection by means of reducing the production of greenhouse gases, particularly carbon dioxide (Cetkovský et al., 2010).

Another argument in favour of wind farms is the fact that the energy return on energy invested is much faster in wind farms than in case of nuclear or coal fired power plants. The

time when a WF generates the same amount energy as expended to construct it ranges from 6 to 12 months at the WF lifespan of 20 years (Mathew, 2006).

Building a WF strains the site in a minimum manner and, roughly, it is a question of one month. Dismantling of the structure takes 2-3 days and the structure hardly leaves any traces in the ground. Wind farms are excellent examples of multifunctional utilization of areas, which means that they permit utilization of agricultural land almost in the original extent both for plant growing as well as for pasturage.

Thanks to reducing specific costs of a generated kWh from wind it may be expected that in the next few years the price of electric power generated from wind and brown coal shall level off (Mathew, 2006).

2.2 Utilization of wind power within the Czech Republic in the past

The first mention of a windmill in Europe comes from 833. Historical sources relate the construction of the first windmill within the territory of the Czech Republic to the year of 1277, namely in the garden of the Strahov Monastery in Prague. The oldest reference from Moravia and Silesia comes from the Opava region and dates back to 1340. Before the 17th century the mentions of windmills are sporadic. In the 18th century the development of wind millery was stimulated by a court decree on the establishment of windmills of 1784, which pursued the objective for each community to have a windmill. As a result, there were thirty windmills registered in Moravia and Silesia. The boom of wind millery in Bohemia is connected with the first half or the first two thirds of the 19th century (Pokorný, 1973). In total, 198 localities with windmills were documented in Bohemia then. In Moravia and Silesia the boom occurred later, namely in the second half or last third of the 19th century and beginning of the 20th century. Within Moravia and Silesia there is a documented existence of 681 windmills (Burian, 1965). In total, within the territory of the CR there was a proven existence of 879 windmills (Cetkovský et al., 2010).

2.3 Development of wind energetics world-wide and in the Czech Republic

Along with cumulative problems in connection with fossil fuel utilization and environmental protection, wind energetics is getting into the forefront of interest and a formerly marginal and low prospective branch is gradually becoming one of the major trends of the world-wide power engineering.

There are registered attempts of wind exploitation for power generation from the very beginning of electroenergetics as such. However, a more systematic development in the sphere of wind energy may be dated approximately into the second half of the 1970s. Oil shocks at that time brought attention to limited classical sources of energy and led to a search for alternatives, wind energy being one of those. As in the nature of new technologies, the beginnings were not easy and for a long time wind energy appeared as interesting but expensive, and not a very utilizable option in a wider scale.

Nevertheless, development continued especially after a strong impulse from California which introduced a temporary generous support for wind energy in the 1980s. From today's point of view of miniature wind farms this era is responsible for the famous arrays in the Californian passes of Tehachapi or Altamont. The technology was in its infancy then and not all the attempts brought success. However, the "Californian boom" contributed to testing various technological concepts and an elimination of diverse development dead ends.

The following years were characteristic for a slow but more organized development under a systematic support, particularly from the part of Denmark and, to a smaller extent, some

other European countries (particularly Denmark much benefited from the support and, as a result, it has currently become a technological leader in the field and wind energetics represents a considerable contribution within the national economy). The basic technological principle of wind farms does not change much nowadays, but it is their reliability, efficiency and last but not least their size that grow gradually. This jointly contributes to lower costs per unit of energy produced and permits a meaningful construction of wind farms also outside prominent localities on the sea coast (Cetkovský et al., 2010).

A country which also takes advantage of the opportunity apart from Denmark is Germany. In connection with introducing favourable and transparent conditions for wind energy purchase and granting permissions for wind farm constructions there was an unprecedented development in the construction of wind farms, which started approximately in the mid 1990s and peaked in the early 21st century. At that time wind energetics turned out to be a considerably inexpensive method how to generate clean energy from home sources and not a mere inconvenient “alternative” technology.

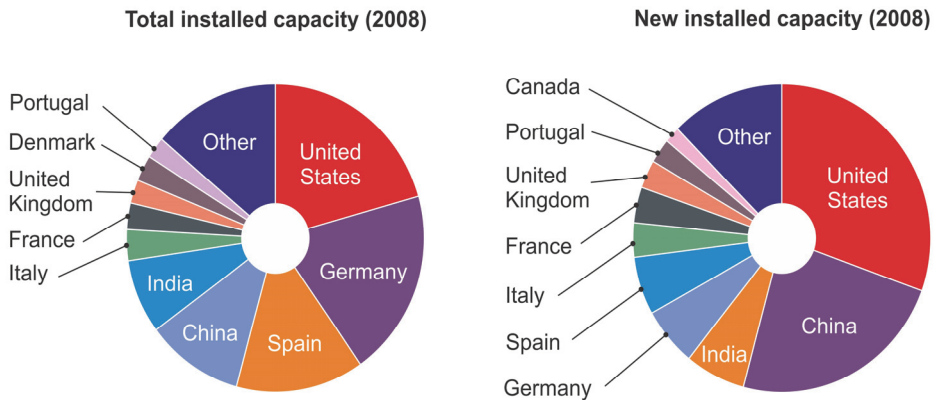

Fig. 1. Participation of the individual countries on the total wind farm output (left) and on the increase in the installed power capacity (right) in 2008 (according to GWEC - Global Wind Energy Council data)

Globally, the present times may be seen as a vast boom in the construction of wind farms. This trend is given by having perfected the technology compared to the past (lower breakdown rate and noisiness of the wind farms, higher outputs), a significant drop in their cost and higher interest in the exploitation of wind energy due to high and unstable oil prices as well as growing urgency of environmental issues and forthcoming climatic changes.

While the first surge of wind farm erection concerned a rather narrow number of countries with Denmark and Germany leading the list (including Spain since 2000), since 2005 there has been a massive expansion of wind energetics across the continents. Recently, wind energy has been systematically supported in the USA and China and nowadays also in a number of European countries (e.g. France, Great Britain, Portugal, Italy) as well as in extra-European countries (traditionally India, followed by Canada, Japan, etc.). The United States along with China have become leaders as for the countries with newly installed power

capacities, even if much smaller Germany and Spain (behind the USA) still maintain strong positions as for the so far installed power capacity thanks to their head start.

Overall, in 2008 the world-wide installed capacity of wind farms reached the level of 120 GW, out of which 26 GW were gained last year (for a better idea: the total installed capacity of all the power plants in the Czech Republic is about 17.5 GW). The appreciable significance of wind energetics is documented by the fact that within the European Union energy from wind covered 4.2 % of electric energy consumption in 2008 and that year wind farms achieved the highest increase ever in the installed capacity among all the energetic sources.

As for the future development, a decrease in constructions may be expected in the regions where power energetics broke through as first, i.e. particularly in Germany and Spain. The construction of wind farms is slowly facing a shortage of suitable inland localities and power system limits as for the generated power transmission. However, an intense development will continue in other European countries, particularly in the extra-European ones and globally the existing record growth of wind energetics is likely to be beaten. In the near future, we should also live to see a more extensive construction of off-shore wind farms, mainly in the area of the North Sea. It is in case of the “off-shore” wind farms where major technological innovations may be expected and in all probability, for example, floating wind farms to be erected in deep waters or huge off-shore wind farms with an output of over 10 MW may even be anticipated (Cetkovský et al., 2010).

The Czech Republic cannot be included among advanced states as for wind energy exploitation even if the historical development may suggest otherwise. The fact that a lot of attention was paid to wind energetics in the Czech Republic in the past is evidenced by a book by František Kašpar (Kašpar, 1948). The modern development of wind energetics proceeded in two stages in the Czech Republic. The first stage is related to the period of 1990-1995. Then 24 wind turbines were constructed with a total installed nominal output of 8.22 MW. Before 2001 the wind energy purchase prices fluctuated from 0.9 to 1.13 CZK/kWh, which did not make a profit-making operation of WF possible.

The second stage of the development of wind energetics was started by the Energy Regulatory Office price decision for 2002, and gradually also for 2003, which set the minimum purchase price of power generated from wind for the amount of 3 000 CZK/MWh. This price went gradually down to 2 340 CZK/MWh in 2009 and to 2230 CZK/MWh in 2010 and nowadays, but still permits a profit-making construction and operation of wind farm projects.

Since then, the construction of wind farms has been rising slowly. Currently, there are wind farms predominantly in the region of the Ore Mountains (Krušné hory), less in the Drahaný Upland (Drahanská vrchovina) or in the Nížký Jeseník Mountains (Czech Republic). The individual wind farms or small wind farms are operated also in other parts of the Czech Republic. The largest wind farm in the CR was erected in 2007 near Měděnec and the water reservoir of Přísečnice in the Ore Mountains. In total, there are nowadays 24 wind turbines of a total output of 49.5 MW, which thus account for more than a third of the overall wind farm output in the CR. The construction of this wind farm resulted in a rather sharp increase in the installed capacity in 2007 (Cetkovský et al., 2010).

In 2008 an increase in the installed capacity was not that significant, namely due to prolonged delivery dates of wind turbines, blocking the capacities to supply the output into the electric network (wind farm projects and projects of other types of renewable energy sources) and growing obstructions from the part of certain state administration authorities.

By the end of 2008 there were 111 wind turbines in operation in the Czech Republic of an overall output of 145 MW. In 2008 wind participated by 0.29 % on the power generation in the CR. The capacity factor (efficiency) of the majority of the wind farms ranges from 20 to 25 %; rarely, however, wind farms in exposed sites achieve much higher values.

The future development of wind energetics in the Czech Republic is unclear. On one hand, there is a favourable purchase price in favour of constructing wind farms and in many localities of the Czech Republic there are quite good wind conditions. On the other hand, the construction is rather slowed down by a complicated and non-transparent permission-granting process and inconsistent public administration's attitude. The most probable scenario for the next few years is a further but slow increase in new wind farms with annual output increases at the level of about 50 MW (in 2010 mere 20 MW - Lapčík, 2010). However, the real development shall predominantly depend on the support from the part of the political representation which is rather unenthusiastic despite the international agreements and national joint responsibility for a dismal development of the earth's climate. The Czech Republic's wind energy interests are defended by the Czech Wind Energy Association, a voluntary organization of physical and legal entities who are active in the field of wind energy exploitation or are interested in the issue.

3. Technology of wind turbines and their development

A wind turbine is a machine that converts kinetic energy from the wind into electric energy. In dependence on the rotor diameter, defining an area S swept by the rotating blades, the machines are divided into small, medium-sized and large wind turbines (WT).

Among *small wind turbines* (SWT) there are turbines with a nominal output below 60 kW and blade diameter up to 16 m. The most significant category is small SWT with a nominal output below 10 kW, which dominate in producers' catalogues. This group may be divided into two subgroups (Štekl, 2007).

They are micro-sources of a rough output up to 2 or 2.5 kW, the assortment of which is the widest as for the producers. They are small WT with a blade diameter from 0.5 to 3 m, which are solely designed for charging batteries. Such accumulated energy may be used to power communication systems, radio and televisions receivers, fridges and other electrical appliances and light. Small WT have come much useful on sea yachts as energy sources for radio stations, navigation systems, maintaining capacities of starter batteries and lighting. Such devices usually operate with a direct current $12 \div 24$ V.

The second subgroup of the SWT category are machines with a nominal output from 2.5 to 10 kW. These are turbines with a blade diameter from 3 to 8 m, which similarly to the machines of the previous group operate in the stand-alone regime (are not connected to the grid). Such machines have a usual output voltage of 48 to 220 V and they are offered for the house heating or moderate heating purposes, water heating or to drive engines. A published analysis back in 2002 (Štekl, 2002) proved that power generation by such sources for the needs of houses or small farms, which may be connected to the power grid, is not profitable. From the economic point of view, they are justifiable only in places without a possible connection to the grid and a minimum mean annual wind rate of 4.5 m/s at the altitude of 10 m. Power generation by SWT in order to sell energy to power distributors is not economical due to significantly higher specific costs (by as much as several tens of percents).

Thanks to the growing dimensions of new wind turbine blades, the former category of large WT split into two categories, namely *medium sized wind turbines* with a blade diameter from

16 to 45 m and a nominal output ranging from 60 ÷ 750 kW and *large wind turbines* with a blade diameter from 45 to 128 m and a nominal output of the turbines from 750 to 6 400 kW. The largest WTs with a nominal output over 3 000 kW are mostly facilities designed for offshore operations. Producers sporadically offer WT with a nominal output up to 300 kW or WT with outputs ranging 300 ÷ 750 kW. The widest line of products concerns the output ranges from 1 500 to 3 000 kW. Keeping to this fact, the highest number of WT is in this category (40 %) out of all the constructed WT in Germany before 2005 generating 66 % of the German annual WF energy production. The mean output of all the WF constructed before 2005 in Germany was 1723 kW (Ender, 2006).

3.1 Technical solution of wind turbines

3.1.1 Wind turbine rotors

Apart from the meteorological parameters, the output gained from the flowing air depends on the WT rotor swept area and power ratio value (See the Chapter 3.2). Therefore, rotors are the cardinal components of a WT and they have experienced a surprising development for the past 30 years, as for their size, aerodynamic characteristics and operation regimes. For example, back in 2004 there were 90% of WT with a rotor diameter below 60 m in Germany. A lot produced wind turbines used to be three-bladed, mostly with a “pitch” system rotor regulation and a variable number of revolutions. Growing dimensions of the rotors lay high demands on the construction and used materials in order to ensure reliability of operation. Large blades suffer from considerable loads, e.g. at the moment when a large mass of the blades is halted rearranging the blades into a so-called flag position. Apart from small-scale turbulence, possibly huge vertical wind speed gradients, which may in extreme cases reach up to 10 m/s per 100 m, have a negative impact on the lifespan of the material of large blades (Štekl, 2007).

To prevent an increase in the wind speed, which leads to a rise in output, from causing any damage to the generator, a suitable method must be used how to limit the output supplied by the rotor. There are various methods of the rotor output regulation, which are characteristic for the individual types of WT. In principle, there are three methods of control:

- a. regulation when the rotor blades with a constant angle of blades setting cause flow separation, the so-called “stall” regulation,
- b. regulation by pitching the rotor blades into larger angles and reducing the lift force and output, the so-called “pitch” regulation,
- c. regulation by setting the rotor blades into smaller angles and thus reducing the lift force, increasing the resistance and causing a drop in output, the so-called “active stall” regulation.

The turbines regulated by the “stall” regime are simpler in their construction than the turbines with “pitch” regulation, as they do not have a technical system changing the rotor blades setting. When compared to “pitch” regulated wind turbines, technically the “stall” regulation of output has the advantages below:

- simple construction,
- undemanding maintenance with respect to a lower number of mobile parts,
- high reliability of the output regulation.

What is a disadvantage of the regulation method is the fact that the rotor output falls at high speeds, and thus its efficiency decreases too, which happens in case when the wind energy is at its top. Another drawback of the method is the necessary fine adjusting of the blades

frequently after the pilot operation in the given locality. Another *disadvantage* of the rotor is its *inability to start on itself*, which is secured by an *electric motor*. Currently, producers offer the “stall” regulation regime in WT of a nominal output roughly below 1 000 kW, and exceptionally with larger ones.

The “pitch” regulation represents an active system which works with an input signal about the generator’s output. Always when the generator’s nominal output is exceeded, the rotor blades change the stagger angle towards the flow, which causes a reduction in the drive and aerodynamic forces as well as it limits the utilization of the turbine output. For all the wind speeds over the “nominal” speed which is vital to achieve the nominal output, the angle of attack is set so that the turbine provided the required output. Wind turbines with the “pitch” regulation are more sophisticated than the “stall” regulation turbines as the rotor blades setting changes continuously. The “pitch” regulation has the following advantages:

- it permits an active output control within the overall wind speed range,
- when compared to the “stall” regulation, it provides a higher production of energy under the same conditions,
- a simple start of the turbine’s rotor changing the setting of the angle of attack,
- it does not require any strong brakes for a sudden halt of the rotor,
- it limits the rotor blade load at higher wind speeds over the “nominal speed”,
- a favourable position of the rotor blades with respect to a low load in case of extreme wind speeds.

The drawback of this type of regulation is a more complicated and significantly more expensive rotor shafts which must carry enormous force exerted on the blades and, at the same time, ensure a possible pitching of the blade around the blade’s linear axis.

In the initial regimes, the regulation “active stall” is identical to the previous type of regulation, i.e. the “pitch” one. It differs in the last regime when maintaining the constant output is not achieved by increasing the blade setting angle but decreasing this angle. In such a regime it is the case of separation control on the blades, thus “active stall”. The advantage of this type of regulation, compared to the previous one, is lower sensitivity to the surface pollution on the blade’s leading edges (insects).

3.1.2 Wind turbines with/without a gearbox

Besides the traditional technology with a mechanic gearbox ensuring a transmission of a rotor’s low speed into much faster rotation speed of conventional generators, wind turbines without a gearbox are also produced. So far both types of wind turbines have been successful in the international market. Enercon is one of the leaders in the gearbox-free technology. Both the types have their advantages and disadvantages. A decision whether to make wind turbines with or without a gearbox is often a matter of philosophy from the part of the individual producers, while it is the brand’s tradition, development targets and economic analyses that play an important role too.

The gearbox free solution is based on the exploitation of multi-pole low-speed generators. However, they have rather big dimensions, which may cause problems during transport, especially in the megawatt class. On the other hand, there are a significantly lower number of the machine components. There is no need for a large gearbox, connecting parts, there is a fewer number of rotating elements, simpler nacelle and, after all, the maintenance is easier as well. Both in “stall” as well as in power controlled “pitch” regulation and in power controlled system of gondola turning no hydraulic oils are required, which is a great

advantage both for the operation and maintenance. An argument that special generators made only for wind farms in small series are expensive when compared to classical generators is out of place. Along with higher outputs and dimensions of wind turbines, the classical generators and gearboxes are manufactured in small numbers too, which means that a lower price with respect to mass production is not probable.

Traditional constructions of wind turbines are grounded in the use of a drive shaft, bearings, gears and couplings. Technically, all the components are common machinery components that may be supplied by specialized producers. This way it is possible to guarantee a high quality of products at low costs and a possible replacement of a component supplier in order to improve the quality or lower the price. Thanks to the current manufacturing standards of gearboxes, the noise caused by a gearbox does not give cause to construct wind turbines without one. Nowadays, gearboxes are able to last twenty years, while lubricating oil need not be changed that often. The overall machine unit of the gondola is divided into compact components which enable for an easy transport and assembly on site even in the megawatt class.

3.1.3 Wind turbine towers

As clear from company catalogues, the most widespread wind turbine towers are slightly conical steel tubes. Along with a rise in the turbine outputs, towers are becoming higher, as high as 100 to 120 m. Therefore, certain suppliers offer concrete towers for heights over 100 m (e.g. Enercon 4.5 MW near Magdeburg, Germany) and towers in the form of a lattice construction (Štekl, 23007). Lattice towers are perceived adversely due to their “non-aesthetic” appearance and many environmentalists have stigmatized them for damaging the face of the landscape. Other oppose the criticism and say that when compared with the tube towers, the lattice towers have the following advantages in the landscape:

- transparentness, which means that the lattice towers better blend in the landscape, particularly looking from a greater distance,
- minute reflexion of incident light,
- suitable planting into a specific face of the landscape, e.g. forest landscape,
- incorporation into the landscape with already erected structures of such a character (e.g. line masts).

Another advantage of the lattice towers when compared to the tube ones is a lower consumption of steel, which means that at identical costs the produced lattice tower is 20 % higher than the tube one. For instance, the company of Nordex offers a steel tower of 100 m at 319 t and a lattice tower of 105 m at 185 t. The company of Fuhrländer even offers a lattice tower which is 160 m high (weight of 350 t). The assembly of a lattice tower and the transport of its components is simpler, which constitutes a great plus in the construction of wind farms in the mountainous conditions. Having finished the lattice tower by zinc coating a 40-year lifespan is guaranteed, which means no painting the steel tube towers is required.

3.1.4 Wind turbine Vestas V90 – 2.0 MW

Another example is a wind turbine by Vestas Wind Systems A/S, type Vestas V90 – 2.0 MW, which is a characteristic representative of the wind turbine group with a gearbox (from the rotor the mechanical energy is carried by the main shaft via a gear unit onto the generator). Such wind turbines are produced in a mass scale and at present are erected both in the EU countries as well as outside the EU (in the USA, Mexico, Australia, etc.). It must be pointed

out that as for the basic parameters, wind turbines with a gearbox from other producers do not much differ from the Vestas machines, which still belong to the most experienced producers in the field.

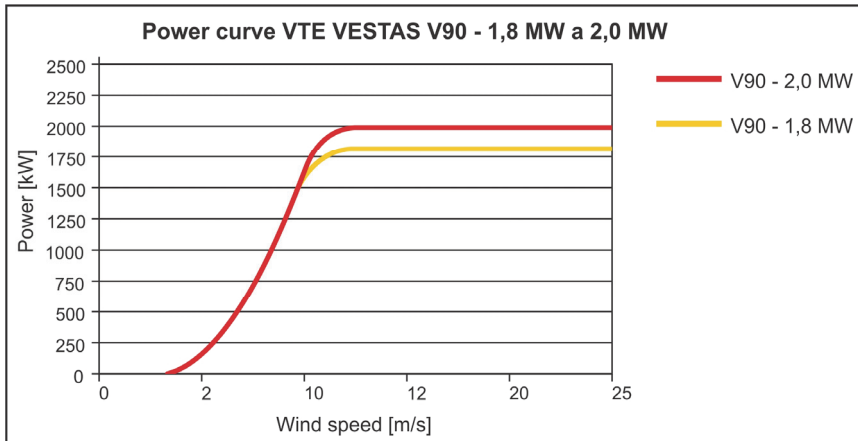

Fig. 2. Wind turbine power curve (Vestas V90)

A Vestas V90-2.0 MW wind turbine has a 45 m long rotor blade (rotor diameter is 90 m – See Figures 3 and 4). It is a slow-circulating machine with revolutions from $9 \div 14.9$ rev/min. The cut-in wind speed is 2.5 m/s, the wind nominal speed is 13 m/s (See Fig. 2), and the cut-out (maximum) wind speed is 21 m/s. Exceeding this speed the machine automatically brakes and shuts down.

The wind turbine is regulated by pitching the blades (“pitch” regulation) by means of an OptiTip® device by Vestas with an active steering the rotor up the wind. By means of OptiTip® the rotor blade setting angles are under permanent control and thus the blade setting angle is always adjusted to the prevailing wind conditions. In this manner, power generation is optimized and noise is minimized.

The rotor blades (Fig. 4, Lapčík, 2009) are made from epoxy resin reinforced by glass fibre (laminate). Each rotor blade is made up from two halves glued together by a carrier profile. Special steel anchoring fills join the rotor blades to a rotor blade bearing. If required, a technology with heated rotor blades may be supplied.

The main machine room and rotor shaft segments are in Figure 6. From the rotor the mechanical energy is carried by the main shaft via a gear unit onto the generator. The gearbox is combined with a planet gear and spur bearing. The output transfer from the gearbox onto the generator is carried out by means of a composite coupling that does not require any maintenance. The generator is special as it is quadripolar, asynchronous and with an advanced rotor.

Braking the wind turbine is conducted via arranging the rotor blades into a so-called flag position. The parking disk brake is situated on the high-speed power shaft.

All the wind turbine functions are controlled by control units based on a microprocessor base. This operation control system is placed in the nacelle. Changes in the rotor blade setting angle are activated via a torque arm by a hydraulic system which allows the rotor blades rotate axially by 95° .

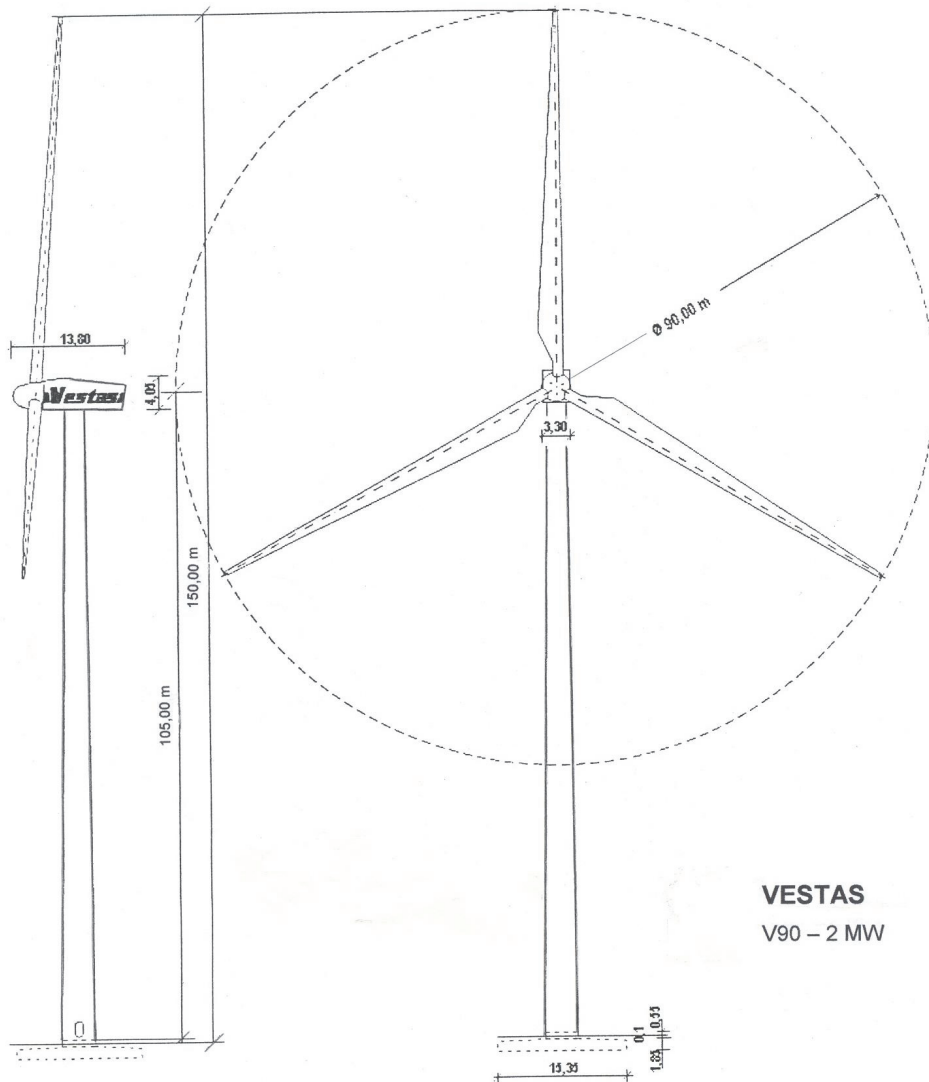

Fig. 3. Wind turbine of Vestas company - an overall view

Four power driven gearboxes are responsible for positioning the nacelle up the wind turning the pinions that reach into the dents of a yaw bearing placed on the top of the tower. The bearing system of positioning up the wind is a sliding bearing system with a built-in friction and self-locking function.

The nacelle cover (Fig. 6) made of plastic reinforced by glass fibre protects all the components inside the nacelle from rain, snow, dust, solar radiation, etc. The gondola is accessible through a central aperture from the tower. Inside the nacelle there is a jib crane for maintenance.



Fig. 4. View of a rotor blades, nacelle and upper section of the Vestas wind turbine tower

There has been a significant development in the wind turbine towers, which have grown from the original 20 m to 100 or 120 m, or higher in extreme cases. The most widespread are poles in the form of slightly conical steel tubes. Currently, at the heights over 100 m the poles are usually made of concrete or combine steel and concrete. A possible option are lattice construction poles which are advantageous both as for their price and construction. However, they are refused by a group of "environmentalists" who feel that the towers damage the face of the landscape.

A conical steel tubular tower (Vestas) is either 105 metres or 80 metres high (Fig. 3 and 4). The diameter of the ground flange is 4.15 m (Fig. 5), the top flange diameter is 2.3 m. It is supplied with a finish in a green-grey colour. The tower is anchored into the foundation in the form of a ferroconcrete plate of about 16 metre diameter, height of 1.9 m (on a footing bottom in the depth of 3 m). The foundation is placed below the ground surface and topped with a one-metre-thick layer of ground.

The total weight of the technological part of the wind turbine (without the foundation) is 331 tons (gondola 68 t, rotor 38 t, tower 225 t).

The wind turbine is constructed for the temperatures ranging from -20 °C to +55 °C. Special measures must be taken beyond the afore mentioned temperature range.

Beside the wind turbine there is a container concrete transformer station (in the majority of cases there is one transformer station for three machines). The transformer is oil, two-winding in a container version. The transfer is from 690 V to 34 kV and the nominal output is 1.6 MVA. Nowadays most of producers place the transformer station directly inside the wind turbine tower.



Fig. 5. View of the anchorage of the wind turbine pole into the anchor plate (Lapčík, 2008)

3.2 Calculation of wind turbine output

The term of wind power density P is understood as the capacity which could be obtained at hundred-percent exploitation of the kinetic energy of the wind flowing by an area per unit perpendicularly to the flow direction. It may be determined according to the relation

$$P = \frac{u^3}{2} \cdot \rho \quad [W/m^2] \quad (1)$$

The wind power density passing through the plane S [m^2] perpendicular to the flow direction is expressed as below

$$P_S = \frac{u^3}{2} \cdot \rho \cdot S \quad [W] \quad (2)$$

The power of a wind turbine removed from the blowing air through the turbine rotor P_s is expressed by the relation below

$$P_s = \frac{u^3}{2} \cdot \rho \cdot S \cdot c_p \quad [W] \quad (3)$$

where

u ... wind speed (m/s),

ρ ... specific weight of the air (kg/m^3),

S ... rotor swept area (m^2),

c_p ... power coefficient (-) which is dependent on the extent to which the rotor decreases the speed of the flowing air; the power coefficient has a theoretical maximum $c_{p\text{max}} = 0.593$, really is value to 0,5.

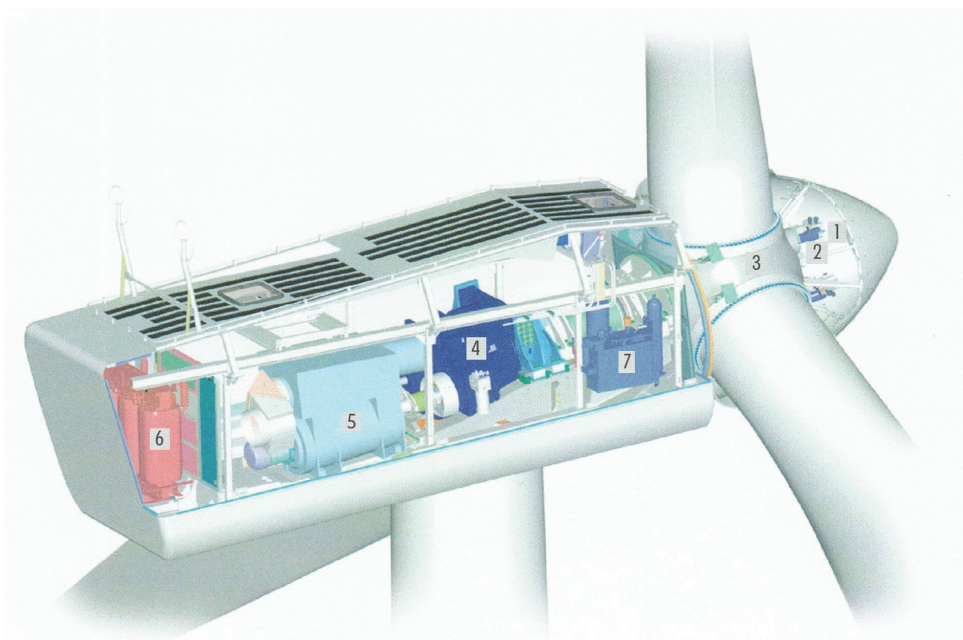

Fig. 6. View of the wind turbine nacelle: 1 - hub controller, 2 - "pitch" control cylinders, 3 - blade hub, 4 - gearbox, 5 - generator, 6 - high voltage transformer, 7 - hydraulic unit (Vestas, 2009)

The dependence of power in the wind on the air density in the real atmosphere is expressed by a function of the altitude and further on, it is a function of an aperiodic alternation of warm and cold air masses (Štekl, 2007). Roughly, if we take as a basis a wind turbine output at the sea level, the output will be lower by 5 % at the altitude of 500 m, at the altitude of 800 m by 7 % and at the altitude of 1200 m by 11 %.

The output produced by a wind turbine is indicated by a power curve (See Fig. 2 above), which is a basic indication of each wind turbine type.

It is apparent from the relations above that the wind turbine output depends on wind speed in an extraordinarily sensitive manner. It is clear that evaluating the wind potential, errors in wind speed determination may thus project into the result in a negative way.

Pursuant to the law, the power grid operator is obligated to take electric power generated by a wind turbine at a rate set by the Energy Regulatory Office price decision. According to this price decision for wind farms put in operation after 1st January 2010, the purchase price of

power supplied to the network is 2.23 CZK/kWh and for wind farms put in operation after 1st January 2009 it was 2.34 CZK/kWh. In 2008 it was 2.55 CZK/kWh, in 2007 2.62 CZK/kWh and in 2006 it was 2.67 CZK/kWh.

In 2008 the new wind turbines in Germany belonged to Enercon 52 %, Vestas 32 %, REpower 6 %, Fuhrlander 5 %, Nordex 2 % and other companies are represented by three percents (Ender, 2009).

The technology of wind turbines has experienced an extraordinary progress since 1980, a beginning of the modern wind energetics in Europe. The development has been manifested by:

- increasing the WT output per unit due to a growth in rotor diameter,
- increasing the WT tower height and reducing the adverse influence of the earth surface roughness,
- higher quality WT demonstrated by lower break-down rates, noisiness and demands of operation,
- lower specific costs of the generated power.

4. Environmental impacts of wind farms

Assessing the environmental impacts of wind energetics projects the following factors must be taken mainly into consideration (Lapčík, 2008, 2009):

1. noise,
2. impacts on the face of the landscape,
3. impacts on the migration routes and bird nesting, impacts on the fauna, flora and ecosystems,
4. stroboscopic effect,
5. impacts on the soil, surface water and ground water,
6. other impacts.

4.1 Noise

Operating a wind farm two types of noise arise. It is a **mechanical noise**, the source of which is a **machine room** (a generator including a ventilator, gearbox, rotation mechanisms or a brake). The amount of noise emitted into the environment depends on the construction quality of the individual components (e.g. gearwheels) of the overall machine as well as on the placement and enclosure of the overall machinery. All the stated parameters of the currently lot produced wind turbines are optimized. Except for small deviations when turning the gondola, the noise is stable.

Certain noise impacts result from the blades passing the wind turbine tower. In the past, pole vibrations appeared in some wind turbines, which has been overcome by modern technologies (Štekl, 2007). Next, it is an **aerodynamic noise** that arises due to the interaction of flowing air and the rotor airfoil and whirl winds relaxing behind the blade edges. Its frequency spectrum is very balanced and falls with a rise in frequency. Aerodynamic noise is reduced by the state-of-the-art constructions of rotor blades or rotor types when at the expense of a slight fall in the generator's output the noise levels are reduced.

The noise spreads from the point source in dependence on the direction and speed of air flows, in dependence on the intensity of vertical mixing of air (below the temperature inversion the transfer of noise is prevented in the vertical direction), on the shape of the

earth surface and on the existence of obstacles to the noise spread. The noise spreading from the point source subdues along with the distance. A simplified version deals with a drop in the acoustic pressure along with a distance logarithm as a wind speed function. Mostly, this simplified version of the calculation (i.e. without the influence of the wind rose, relief shape, temperature layers, etc.) is used in model calculations to define an noise field in the surroundings of a wind farm.

The intensity of the perception caused by noise is greatly influenced by the proportion between its intensity and the intensity of other noises labelled as the **background noise**. It is known that a noise caused by a viscous and turbulent friction of air and the earth surface reaches high values, especially in the mountain conditions. For instance, during a windstorm human speech becomes difficult to understand under such conditions. In the test polygon in Dlouhá Louka in the Ore Mountains measurements were conducted that showed that at wind speed up to 5 m/s the background noise level was within the limits $30 \div 40$ dB, but at the wind speed about 6 m/s the background noise was from 33 to 47 dB. At the wind speed over 8 m/s the noise exceeded the value of 45 dB (Štekl, 2007).

Government Decree 148/2006 Coll. on health protection against negative impacts of noise and vibrations sets the top admissible level of acoustic pressure outdoors at 50 dB during the day (06 ÷ 22 hours) and at 40 dB at night. However, this decree does not consider the circumstances when the background noise exceeds the noise produced by a wind farm.

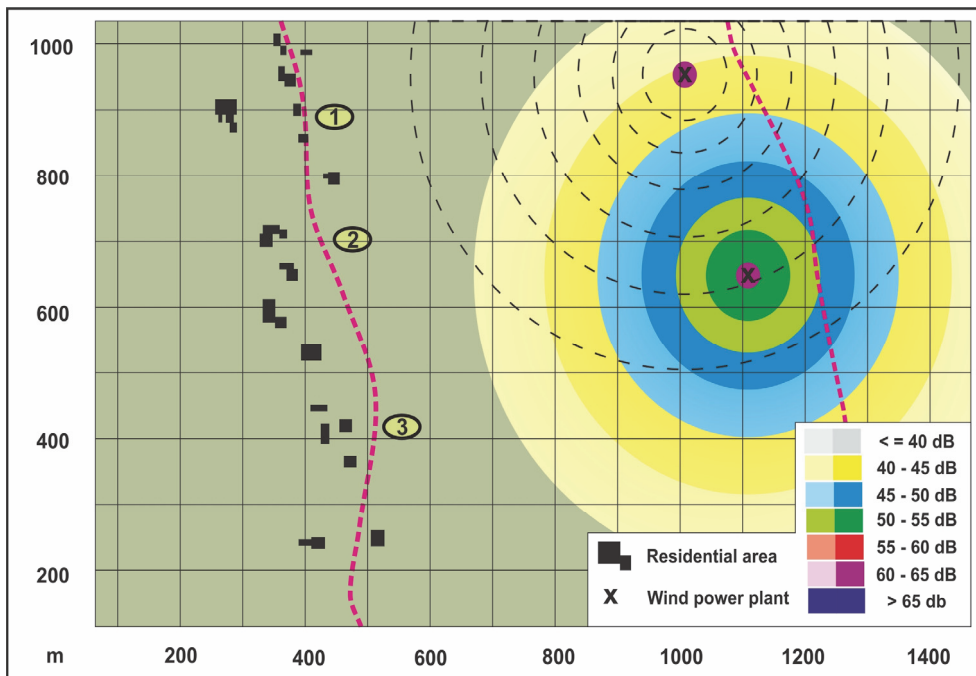

Note: Wind turbine No. 1 (in the top) is shut down at night time. Check point of noise – points No. 1, 2 and 3.

Fig. 7. Equivalent levels of noise – night operation of wind farm.

The own assessment of acoustic situations is carried out by means of a noise study which assesses the noise near the nearest built-up area. It happens that the admissible equivalent noise level is not observed in the loudest night hour in the outside protected area. In such cases, the wind farm regime is required to be limited via reducing the output, which thus results in lowering the acoustic output (e.g. from 109.4 dB to 102.0 dB). In some cases it is though necessary to switch off several machines at night – See Fig. 7 (Lapčík, 2006, 2007, 2009). For example, in Germany it is recommended to construct wind farms more than 300 m from a single residence and more than 500 m from an end of a settlement. Nevertheless, the experience of the monograph author is that the minimum distance of wind farms from any housing development should be 575 to 600 metres.

Traffic noise arising in the time of construction and operation of a wind farm is time limited and usually negligible. In the time of construction it is important to ensure disposal of the spoil in the volume of about 770 m³, delivery of concrete in the volume of about 490 m³ per one machine and delivery of the own technological facility (Lapčík, 2006, 2007, 2010). In the time of operation, there are only one or two vans per week.

The impact of traffic noise and its changes in connection with construction and later operation of wind farms mostly shows in the day in the surroundings of the access road to the site. As the points for calculations, for which the calculation of noise from stationary sources is carried out, are often far away from the road, it is important to describe changes in the noise situation in a noise study changing the equivalent noise levels in a standardized distance from roads (e.g. 7.5 m from the axis of the closest lane).

4.2 Impacts on the face of the landscape

A term of the face of the landscape has been introduced by Act 114/1992 Coll. on the conservation of nature and landscape. Therein, the face of the landscape is defined (§ 12) as a natural, cultural and historic characteristics of a particular site or region. The face of the landscape is protected against activities degrading its aesthetic and natural value. Interference with the face of the landscape, particularly as for locating and approving structures, may occur only with regard to keeping significant landscape elements, especially protected areas, cultural dominant features of the landscape, harmonic criteria and relations in the landscape.

Talking of the impacts on the face of the landscape, in case of complying with measures connected with the interests of health protection against unfavourable impacts of noise and the interests of the nature conservation, the impact on the face of the landscape may be defined as a dominant aspect in connection with the assessed type of project.

There is no doubt that the erection of wind farms embodies a highly visible interference with the face of the landscape. As for the protection of the face of the landscape it is vital to find out if the planned structure does not interfere with any natural park. Stipulated by law, a natural park represents one of the most sensitive areas in the protection of the face of the landscape and a construction of a wind farm should not be implemented there. Natural parks are landscapes with concentrated significant aesthetic and natural values for the conservation of which they have been established (in accordance with § 12 art. 3 of Act 114/1992 Coll. on the conservation of nature and landscape, as amended). It is solely the protection of the face of the landscape which makes the core of their protection.

Visualization of wind farms is usually processed by means of computer animation and making use of photographs of the existing landscape in order to assess the impacts on the face of the landscape – See Figure 8 (Lapčík, 2009).



Fig. 8. A view of photo-visualized wind farm

The site of the face of the landscape affected by the assessed wind farm plans (i.e. an area from where wind farms can be potentially seen) is usually a vast territory. The site of the face of the landscape, i.e. an area which may be visually influenced by the assessed structure, is considered in terms of distance views as far as 2 to 5 km in case of a strong visibility range and as far as 10 km in case of a clear visibility range – by course of a Methodical Direction 8/2005 (Methodical Direction of the Ministry of the Environment No.8, June 2005). Areas which are shaded by forming the georelief are excluded from the ranges.

There is a frequent question whether it would be possible to generate an identical volume of electric power by wind farms even at possible lowering of their towers and reducing the rotor diameters as in this manner the face of the landscape would be less altered. The calculations may be carried out on the grounds of known relations for the calculation of wind (P_s) power (See Chapter 3.2 above).

The calculation results though imply that shortening the wind turbine pole height from 100 metres to 70 metres (at wind speeds $c = 8.5$ m/s and $c = 6.5$ m/s) and using a rotor of 90-metre diameter, the electric power fell from 100 % (pole height of 100 m) to 45 % (pole height of 70 m). Using a rotor of 50-metre diameter (instead of 90 m) the electric power would drop to 31 % (pole height of 100 m) or to 14 % (pole height of 70 m) – (Lapčík, 2006, 2007, 2008).

It is thus clear that lowering the pole height or reducing the wind turbine rotor diameter there would be a considerable loss in the gained electric power and practically an analogous facility with all its negative environmental impacts would have to be constructed (noise, land required for the machine's foundations, access roads, energy infrastructure, etc.) as if implementing a wind turbine of 100-metre-high pole and 90-metre rotor diameter. At the same time, the impact on the face of the landscape in smaller machines would be identical. The facilities would only appear to be located further away from the observer than in case of higher facilities (higher pole and wider rotor diameter).

4.3 Impacts on the migration routes and bird nesting, impacts on the fauna, flora and ecosystems

The literature does not report any significant negative impacts of wind farms on birds. The results of a wind farm impact research on the avifauna in the Netherlands (Winkelman, 1992) imply that no verifiable impacts on nesting birds or birds perching for food into the vicinity of wind farms have been registered. A long-term observation of 87,000 birds in the vicinity of wind farms show that the majority of birds completely avoided the wind farms (97 %) and only a fraction chose to fly through a rotor. This usually results in a clash with a blade. Despite being hit by the blade there is no inevitable rule of a serious injury or death of the bird. The existence of a pressure field in front of the rotating blade forms a barrier which often repels the birds.

Experience from the observation of bird behaviour close to wind farms has also been gained in the Czech Republic. For example, in the Ore Mountains in the surroundings of the municipality of Dlouhá Louka a detailed research in nesting bird associations in three most significant biotopes (in the forest, on the meadow and cottage settlement) was carried out in 1993 and 1994, i.e. prior to and after the construction of a wind farm. The results presented in the study document that the operation of the wind farm does not affect nesting of bird associations in a significant manner.

Based on surveys, possible risks connected with wind farm operation (particularly collisions of birds and bats with the facility) are greater than those related to an operation of other similar structures (high towers, high voltage wires, roads, etc.). Moreover, it may be said that in the majority of cases applying suitable technical solutions there is no reason to expect distinct degradation of the conditions of the site suggested for the construction of wind farms from the environmental point of view.

Nevertheless, it is convenient for wind farms to be located outside important birds' migration routes and breeding places. This may be checked preparing a study which assesses impacts of planned wind farms on birds and other vertebrates.

The wind farm structures are mostly situated outside the component parts of the ecological stability zoning system, outside areas of higher degrees of ecological stability, or outside localities with near nature ecosystems. Also, a possible impact on especially protected areas and biotopes of specially protected animal species is negligible. In order to exclude unfavourable impacts on the flora and fauna it is advisable to process a biological (floristic and faunistic) assessment of the localities in question.

4.4 Stroboscopic effect

Stroboscopic effect is a phenomenon when rotating objects lit by a periodically variable light do not seem to be moving. In case of wind farm operation it is a rather a possible effect of gleams and shading by a mobile shade under the sunlight. The gleams of light from the rotor blades may be eliminated by a matte finish of the rotor blades (e.g. in grey colour).

If a rotor of commonly applied wind turbines rotates within the range of 8 to 17 revolutions per minute, the frequency of gleams is at the level of 0.4 Hz to 0.9 Hz. Safely outside the frequency from 5 to 30 Hz, it is however on a level which could cause the so-called photosensitive epilepsy in sensitive people found near wind farms.

Shading by a mobile shade may be observed in wind farms at optimal light conditions within 250 to 300 metres from the wind farm. It is practically negligible at further distance. With regard to the fact that the majority of assessed wind turbines are usually located in the distance of 500 metres from any residence, this phenomenon appears as minor.

4.5 Impacts on the soil, surface water and ground water

One wind turbine is expected to take up an agricultural land from 0.10 to 0.13 ha, where the own built-up area for the machine is about 200 m² (Lapčík, 2006, 2007, 2010). Mostly, it is land with predominantly substandard production capacities and limited protection. Having terminated the wind turbine operation, the land is expected to be reclaimed for possible agricultural use. The stabilized access roads can be used as access roads for pieces of land from the adjacent roads.

The operation of wind turbines does not produce any technological water or sewage. The rainwater from the stabilized access road areas is mostly drained gravitationally into the surroundings and the ditches.

The impact on the surface and ground water is not expected implementing such projects, but it is important to adhere to all the relevant safety measures. The wind turbine facilities do not influence surface water or the quality, water level or flow directions of the ground water, both during construction and own operation. However, during construction of service roads and the wind turbine facilities it is important to take such measures to prevent

changes or worsening of water discharge, the occurrence of the manifestations of erosion or to limit the pollution and soil drag into influent stream beds to minimum in course of construction.

4.6 Other impacts

Within the winter operation there may be a situation when *ice* or *ice fragments* fall off the blades. New wind turbines are expected to be equipped with signalling which recognizes ice in time or the wind turbine is shut down. Also, technical equipment is expected which is able to prevent the formation of ice in an effective manner (the rotor blades are produced from such materials that prevent clinging of the ice onto the blades).

A minimum measure in this respect is an installation of panels warning about a possible risk of injury due to falling ice off the rotor blades in a sufficient distance from wind farms (about 250 m).

5. Conclusion

In the Czech Republic a big number of wind turbines and wind farms are being prepared to be constructed. Nevertheless, the implementation of the approved structures is progressing rather slowly. The total installed capacity of wind farms in the Czech Republic had been 50 MW by the end of 2006 (Koč, 2007). By the end of December in 2009 the Czech wind farms had a total installed capacity of 192,9 MW, by the end of November in 2009 then a total installed capacity of 212,6 MW.

Wind farms of a total installed capacity higher than 500 kW_e or with tower height exceeding 35 meters are classified according to the Appendix 1 to Act 100/2001 Coll., as amended, into the category II (projects requiring rogatory proceedings), article 3.2 (the project is administered by Regional Offices). This implies that the majority of the designed wind farms in the Czech Republic nowadays must undergo rogatory proceedings.

As a rule, a number of studies make parts of the notification processed according to Appendix 3 to the Act. For example, they are a noise study, assessment of impacts on the face of the landscape, assessment of wind turbine impact on birds and other vertebrates, or the project's impact assessment on Europe's outstanding localities and birds' territories according to §45i of Act 114/1992 Coll. on the conservation of nature and landscape, as amended. Certain notifications also contain health risk assessments, which are required by the law processing the documentation according to Appendix 4 to Act 100/2001 Coll. on environmental impact assessment, as amended.

Nevertheless, despite the complications (the notification actually takes the form of documentation) in the majority of cases the process of impact assessment for wind farms is not currently discontinued within the rogatory proceedings (in the so-called shortened proceedings), but it must be continued in the full extent (documentation compilation, opinion elaboration, public hearing), often with repeated supplements to the documentation before the opinion is elaborated.

This is caused by the negative attitude of the regional offices as well as of the public to wind energetics, who mostly hold a negative attitude to this renewable source of energy. Nevertheless, it must be said that the public comments are frequently presented in a very general manner and still certain types of criticisms reappear even if those have already been discussed and disproved.

With regard to the above mentioned public and regional offices' attitudes to wind farms, the environmental impact assessment process for the facilities is protracted and complicated (in the majority of cases the full assessment process must be taken into account).

6. References

- Burian, V. (1965). Wind Mills in Moravia and Silesia. *Proceedings of Homeland Study Institute in Olomouc*, Issue 7, 79 p. (in Czech).
- Cetkovský, S., Frantál, B., Štekl, J. (2010). *Wind Energy in the Czech Republic: Assessment of Spatial Relations, Environmental Aspects and Socio-Economic Context*, Czech Academy of Sciences. 208 p. ISBN 978-80-86407-84-5. (in Czech).
- Ender, C. (2006). Windenergienutzung in der Bundesrepublik Deutschland - Stand 30.6.2006. *DEWI Magazin*, No. 29, pp. 27-36.
- Ender, C. (2009). Wind Energy Use in Germany - Status 31.12.2008. *DEWI magazin*, Vol. 34, pp. 42-58.
- Kašpar, F. (1948). *Wind Engines and Power Stations*, Part 1, Czechoslovak Electrotechnical Union, Prague. 367 p. (in Czech).
- Mathew, S. (2006). *Wind energy. Fundamentals, Resource Analysis and Economics*.
- Koč, B. (2007). Record Year of Wind Generators in Europe, *Alternative energy*, Vol. 10, č. 2, pp.32-33. (in Czech).
- Lapčík, V. (2006). Notification according to Czech Act No 100/2001 Coll. on environmental impact assessment, as amended, of project „Wind Park Potštát-Lipná“. Ostrava. 75 p. (in Czech).
- Lapčík, V. (2007). Environmental Impact Assessment in Branch of Wind Power Plants and Corresponding Studies. *SEA/EIA 2007 Conference Proceedings*, Ostrava, pp. 64 - 70.
- Lapčík, V. (2008). Environmental Impact Assessment of Wind Generators in the Czech Republic, *Acta Montanistica Slovaca*, Vol. 13, Issue 3, pp. 381 - 386. Technical University of Košice. ISSN 1335-1788. (in Czech).
- Lapčík, V. (2008). Notification according to Czech Act No 100/2001 Coll. on environmental impact assessment, as amended, of project „Wind Park Partutovice“. Ostrava. 77 p. (in Czech).
- Lapčík, V. (2009). *Industrial Technologies and their Impact on Environment*. (monograph), VŠB-Technical University, Ostrava. ISBN 978-80-248-2015-6. 362 p. (in Czech).
- Lapčík, V. (2010). Documentation according to Czech Act No 100/2001 Coll. on environmental impact assessment, as amended, of project „Wind Park Potštát-Kyžlířov“. Ostrava. 91 p. (in Czech).
- Mathew, S. (2006): Wind energy. Fundamentals, Resource Analysis and Economics.
- Pokorný, O. (1973). *List and Location of Wind Mills in Bohemia*, *Studia geographica* 18, Geographic Institute of Czech Academy of Sciences. 179 p.
- Štekl, J. (1993). Wind Energy for Production of Electric Energy in the Czech Republic. Research report for EACR, Institute of Physics of Atmosphere, Czech Academy of Sciences. 65 p. (in Czech).
- Štekl, J. et al. (2002). Final report of project VaV 320/6/00, subproject Wind Energy. Vol. 1 and 2. Prague: Institute of Physics of Atmosphere, Czech Academy of Sciences. 117 p. and 82 p. (in Czech).

Štekl, J. et al. (2007). *Renewable Energy Resources and their Possibilities of Utilization*, ČEZ, a.s. Prague, pp. 79-112 p. (in Czech).

Štekl, J. (2008). Will Apply Wind Energy also in the Czech Republic? *Energie (Energy)*, Vol. 21, Issue 1, pp. 31-33. (in Czech).

www.vestas.com

Part 3

Siting Assessment of Wind Farms

Advanced Wind Resource Characterization and Stationarity Analysis for Improved Wind Farm Siting

Scott Greene^{1,2} and Mark Morrissey³

¹*Geography and Environmental Sustainability*

²*Oklahoma Wind Power Initiative*

³*School of Meteorology,*

University of Oklahoma

USA

1. Introduction

A fundamental question of interest is “What are the geographic patterns of the renewable wind resources?” Knowledge of the location of local wind capacity remains vital to the industry, yet commercially viable renewable-related geospatial products that meet the needs of the wind and weather science industries are often suspect. There are three stages involved with wind power project planning and operations during which accurate characterization of the wind plays a critical role:

- Prospecting (Siting): uses historical data, retrospective forecasts, and statistical methods to identify potential sites for wind power projects;
- Site Assessment (Micrositing): determines the placement of a wind power project; and,
- Operations: uses wind forecasts to determine available power output for hour-ahead and day-ahead time frames.

The most critical of these is the first - identifying and characterizing the resource. This chapter will discuss this first stage in detail, outlining the state of the art in understanding the wind resource, and discussing the strengths and weaknesses of existing methods. For example, appropriate statistical and modeling methods to compute the wind speed probability density function (PDF) will be described and critically examined.

In addition, although there has been an increasing awareness of renewable energy as a viable energy supply source, there has not been a concomitant increase in the awareness of the impacts that any spatial and temporal trends in the resource (e.g., in the wind speeds themselves) may have on long-term production, use, and implementation of renewable energy and renewable energy policy. Thus, potential changes of the wind field under a changing climate will also be discussed. As will be described in more detail below, the main topics under examination in this paper are: 1) accurate portrayal of the resource; and 2) potential implications of climate change on the wind resource of the future. The overall result will be an improved understanding of how the siting process works.

2. Wind resource modeling

The first step in determining the amount of potential electrical generation is developing an accurate portrayal of the resource. Thus, for an accurate representation of the wind energy at a particular location, correct estimates of the wind speed are necessary. Figures 1 and 2 illustrate the types of products that are typically used by in determining the wind resource. Figure 1 represents the wind resource at 50 m over the contiguous United States (obtained from the US DoE Wind Powering America program; http://www.windpoweringamerica.gov/wind_maps_none.asp), and Figure 2 is a closer look at a particular state, in this case, the wind resource map for the state of Oklahoma (provided by the Oklahoma Wind Power Initiative; <http://www.ocgi.okstae.edu/owpi>). The fundamental core of these estimates of the resource is a model of the probability density function (PDF) of wind speed. This is increasingly used in the wind power industry where it is required for the assessment of power potential in different locations for wind farm and wind turbine siting (e.g., Hennessey 1977; Garcia-Bustamante et al. 2008; Li and Li 2005; Lackner et al. 2008). The wind power density is required for the estimation of power potential from wind turbines (Justus, 1978). Since it is a function of the wind speed probability density function, it is critical that the wind speed PDF be estimated accurately from the available data. The question then becomes how best to model the resource via fitting the wind speed or wind power density PDF. As stated by Manwell, et al. (2002): "In general, either of two probability distributions (or probability density functions) are used in wind analysis: (1) Rayleigh and (2) Weibull." (See also Conradsen, et al. (1984) for a description of the use of Weibull distribution for determination of wind speed statistics.)

Historically, the wind PDF is most often estimated using a parametric model. These models generally include the Weibull (Stevens and Smulder 1979), Rayleigh (Celik 2003b) and Lognormal functions (Zaharim et al., 2009). The two parameter Weibull function has generally been accepted, and is most often used in research and industry, as an adequate model for the wind speed PDF (Hennessey, 1977; Justus et al., 1979; Pavia and O'Brien, 1986; Ramirez and Carta, 2005; Monahan, 2006). However, as the Weibull distribution has become the industry standard, there have been many attempts to improve its overall applicability for modeling the wind speed PDF. For example, Justus and Mikhail (1976) developed an approach to adjust Weibull shape/scale parameters to a desired height. Stewart and Essenwanger (1978) developed a three-parameter Weibull distribution approach which shows a better fit than a traditional two-parameter Weibull; however, there are significant difficulties in estimating parameters, so its applicability has been limited.

It has been shown, however, that wind speed does not always have a Weibull-like distribution (e.g., Tuller and Brett, 1984, Jaramillo and Borja 2004; Yilmaz and Çelik 2008). The result is that for wind power density computations, large errors in the resource estimation will result from this imperfect Weibull approximation. This is especially true since wind power density is a function of the expected value of the cube of the wind speed (Petersen, et al., 1997). Therefore, there has been range of other approaches attempting to fit the wind speed (or wind power density) PDF. These include: Lognormal (Luna and Church, 1974); elliptical bivariate-normal (Koepl, 1982, who describes the difficulty translating such an approach to univariate (speed-only) distributions); and inverse Gaussian (Bardsley, W.E., 1980, which is offered as an alternative to Weibull distribution, especially in cases with low frequencies near zero).

While much research has focused on parametric and related approaches to this critical estimation of the wind speed or wind power density PDF, when a robust, smooth histogram of the wind speed distribution can be determined from the available data, non-parametric techniques (e.g., Izenman, 1991; Silverman 1986) can also be used given their flexibility and the likelihood that the actual wind power density may not be adequately represented by one of the models listed above (Jaramillo and Borja, 2004). A commonly used non-parametric method in industry and for research is the kernel method (Silverman 1986, Juban et al., 2007). While the kernel method is becoming increasingly popular in industry, there are significant problems with this approach. For example, the PDF functional representation using the Kernel has a number of terms equal to the number of data points used in the fitting process. Thus, the kernel method is not an optimal method for estimating the wind speed PDF, since if a PDF estimator is to be used in further mathematical computations a tractable function with a limited number of terms is required (Hall 1980).

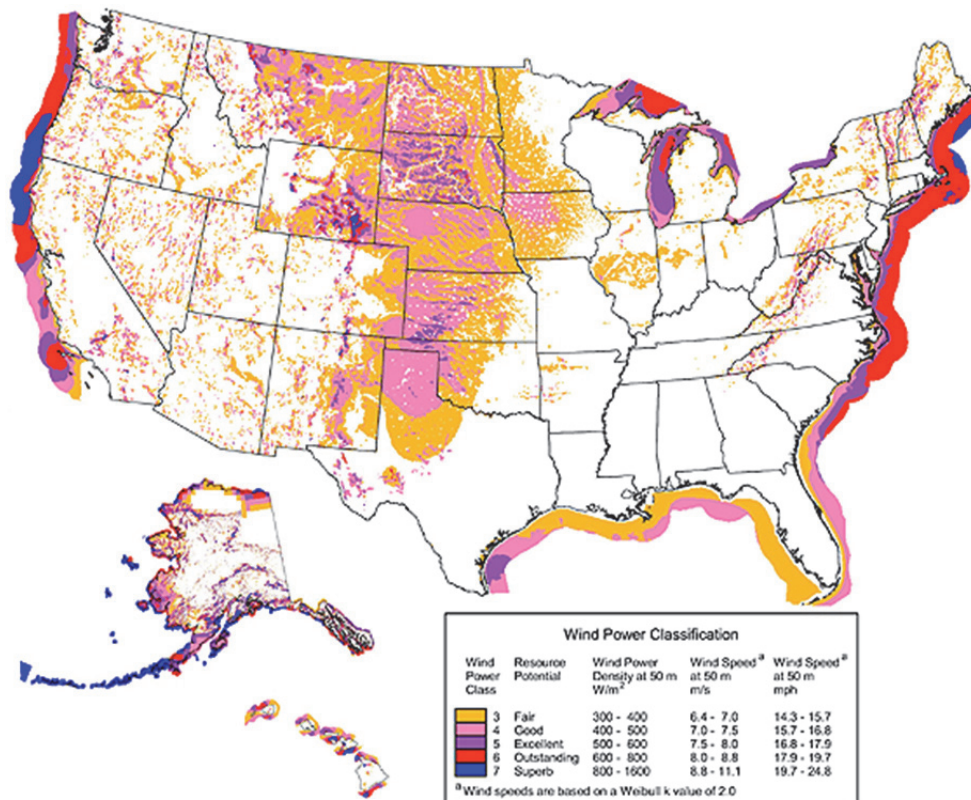

Fig. 1. U.S. Wind Resource Map US wind resource map provided by the Wind Powering America Program (http://www.windpoweringamerica.gov/wind_maps_none.asp)

There has also been recent research to utilize concepts from the field of geostatistics to develop a transform function of the wind speed PDF as a function of scale (Morrissey, et al., 2010a, 2010b). If knowledge of the variance of the wind speed at a given scale is known (or

can be estimated) then the probability density function representing the required scale may be estimated. In simple terms, the PDF from the higher resolution estimates can be ‘upscaled’ to match that from the lower resolution estimates. Thus, the PDFs can be scale-corrected, and the problems associated with the Weibull or other approaches can be overcome. This innovative approach uses the theoretical basis of orthogonal series estimators, or more specifically, Hermite polynomials (Schwartz (1967), Hall (1980) and Liebscher (1990)).

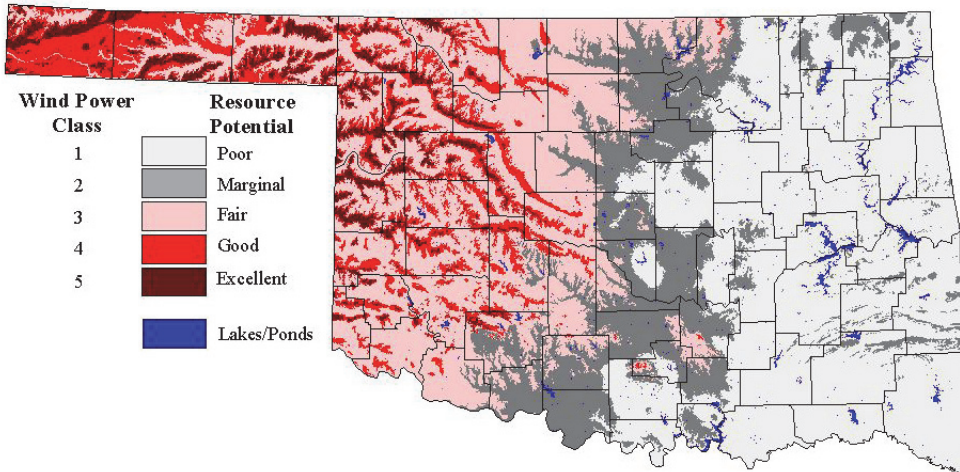

Fig. 2. Oklahoma Wind Resource Map Modeled wind resource provided by the Oklahoma Wind Power Initiative, <http://www.ocgi.okstate.edu/owpi>. Classes are defined as above with Figure 1.

To illustrate this new approach, a series of data fits were applied to a dataset of 10m windspeeds at five-minute intervals from Boise City, Oklahoma, which is part of the Oklahoma Mesonetwork (Brock, et al., 1995). The results are shown in Figure 3. The y-axis in Figure 3 is a representation of wind power density. The value is normalized wind power density per unit speed. The units are watts/square meter/meter per second divided by air density. This value is used so that when the integral of the curve is computed, the units reflect a measure of the actual wind power density. Although not commonly used in previous research, this is how the wind PDF values should be developed, as it is a more representative value of the variable in interest (e.g., actual electrical production).

A standard Weibull fit is compared to a kernel estimator and to a new approach using a Gauss-Hermite polynomial expansion (see Morrissey, et al., 2010a for details on the Gauss-Hermite approach). While there is a noticeable variation in the middle of the distribution, this is less significant in terms of the computation of the overall wind power. The Weibull distribution performs poorly where it matters the most – at the higher wind speeds. As might be expected, both non-parametric methods provide a better fit to the histogram than does the Weibull. The mean squared error for the Weibull distribution is approximately 10 times higher than the value for the other model approaches. Since the upper end of the wind speed distribution is the most significant when attempting to determine potential energy,

this illustrates that the Weibull approach is not the best approach to fit the wind power PDF. For this location, the Gauss-Hermite and Kernel approaches have approximately the same error. However, since the kernel estimates are produced using parameters which are computed over the whole range, there is a tendency and risk that the kernel approach will be too weighted toward the lower (e.g., less significant, from an electrical production standpoint) end of the spectrum, and therefore the Gauss-Hermite approach will yield results which more accurately model the wind power density and the electrical production potential.

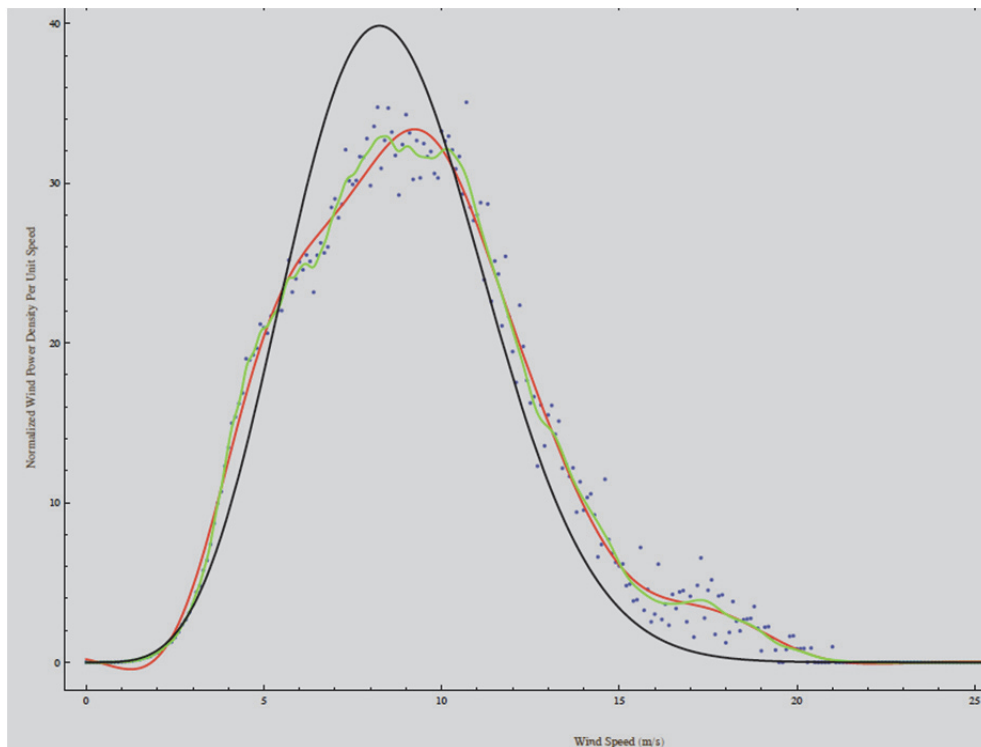

Fig. 3. Actual and Modeled Wind Power Density at Boise City, Oklahoma. Values represent model estimates of scaled wind power density. The Black curve Weibull distribution fit; the Green curve is a Kernel estimator, and the Red curve is a Gauss-Hermite expansion fit.

3. Non-stationarities and impact of climate change

It is well-known that climate change can influence the radiation balance and therefore wind patterns. Recent findings from the Intergovernmental Panel on Climate Change (IPCC, 2007) have shown that greenhouse gas-induced climate change is likely to significantly alter climate patterns in the future. One wind-industry relevant example is that climate change global warming is expected to affect synoptic and regional weather patterns, which would result in changes in wind speed and variability. Therefore, there is a need to examine climate change scenarios to determine potential changes in wind speed, and thus wind

power. Wind power facilities typically operate on the scale of decades, so understanding any potential vulnerabilities related to climate variability is critical for siting such facilities. An exhaustive review of the existing research on the projected impacts of climate change on the wind industry can be found in Greene, et al. (2010). The purpose of this section is not to reproduce that work, but to illustrate what the potential impacts might look like.

Thus, as an example of the specific impacts of climate change on a particular location, future summer wind speed estimates at 10m were computed for Chicago, Illinois. The data used represents estimates of daily wind speed. The dates of the model outputs were: 1990-1999, and for the decades of the 2020s, 2040s, and 2090s This was accomplished by using the Parallel Climate Model (PCM) model, and then downscaling the data. The PCM was developed at the National Center for Atmospheric Research (NCAR), and is a coupled model that provides state-of-the-art simulations of the Earth's past, present, and future climate states (see Hayoe, et al., 2008a, 2008b). The projections for the future using the AOGCM are based on the IPCC Special Report on Emission Scenarios (SRES, Nakićenović et al., 2000) higher (A1FI) and lower (B1) emissions scenarios. These scenarios set the future atmospheric carbon equivalent amounts based upon estimates of a range of variables that could impact carbon emissions. These include estimates of future changes in population, demographics, and technology, among others. The B1 scenario values are considered a proxy for stabilizing atmospheric CO₂ concentrations at or above 550 ppm by 2100, and atmospheric CO₂ equivalent concentrations for the higher A1FI scenario are approximately 1000 ppm (Nakićenović et al. 2000). These estimates do not explicitly model carbon reduction policies, but are considered an approximate surrogates for carbon policy (B1), or a "business as usual" option (A1FI).

The results shown in Figure 4 illustrate the changes in average wind speed throughout the spring and summer months (April – August), for the different decades listed above. Results show a decrease for April -June of approximately 3-5% by the end of the century. There is a slight increase for July and August. Overall for the summer, the total values are approximately equal (decreases of 0-1%), but the changes in the seasonal patterns illustrate the need for a more complete analysis in computing the climate change impact on wind speed and wind power density. Also, potential carbon management policy implications need to be considered. Figure 4 shows that there is a significant difference for the 2090s between the policy and no-policy estimates. For example, the May values show a decrease of 5% for the no policy option, and increase of over 4% for the climate policy estimates. This difference illustrates that for this location, a carbon management public policy would dramatically increase the wind, and therefore the potential for increased electrical production.

4. Summary and conclusions

This chapter has provided an overview of some key points associated with improved understanding of wind farm siting. Specifically, the focus has been on two areas of importance in this topic: 1) accurate wind resource assessment; and 2) potential implications of climate change on the wind resource of the future.

For the first topic, there has been much research into the best way to model the wind speed probability density function, as this is the core basis for estimation of the resource. Traditionally, the industry standard has been to model the PDF using either a Weibull or Rayleigh distribution. It has been pointed out that both of these approaches suffer severe

limitations that call into question their effectiveness, and other approaches have been suggested by a range of different authors. A review of the trends and current state of the wind PDF modeling has been provided, illustrating a several new and potentially useful approaches. However, many of these approaches have the same inherent flaws, in that the efforts have been spent on modeling the wind speed PDF, when what the industry (e.g., utilities and electrical providers) are really interested in is an estimate of the amount of electrical production. Thus, this analysis of the existing research has illuminated two areas of potential improvement. First, continued improvements in the wind PDF modeling, including, for example, adopting approaches from other disciplines, such as the Gauss-Hermite approach illustrated above, are necessary to develop more accurate portrayals of the resource. Second, geographers and climatological researchers need to more effectively link their efforts to industry needs on trying to model, reproduce, and understand the resource of interest to utilities (e.g., potential electrical production) rather than the more simple and straightforward approach of analyzing the climatological variables (e.g., the wind speed).

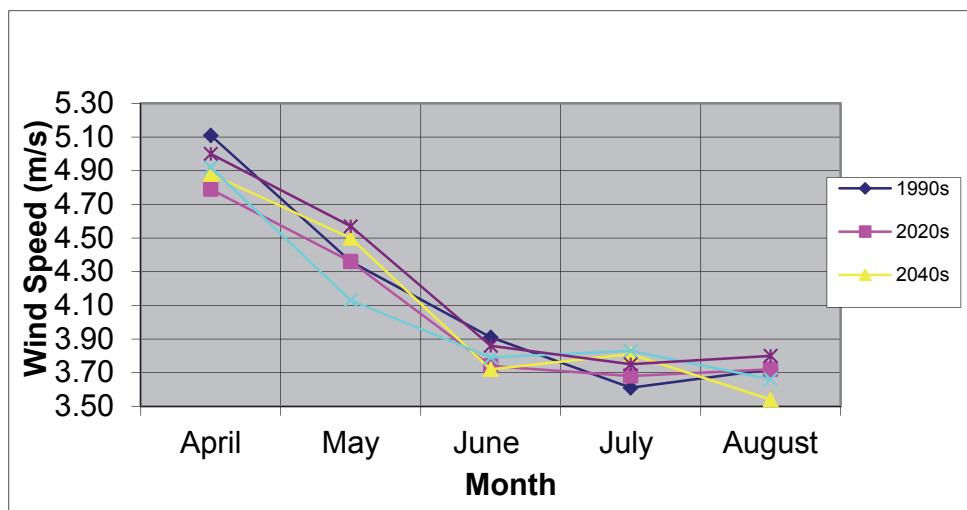

Fig. 4. Estimated Future Wind Speeds, Chicago. Values represent GCM-estimated wind speeds.

Finally, previous research has shown a projected slight decrease in wind speeds in the future, which would result in serious implications for wind farm siting. As shown in the analysis performed here, in the United States, particularly for the wintertime, this is theorized to be associated with a poleward shift of the mean thermal gradient as the earth warms and results in a northward shift of the associated storm track patterns. It is suggested that there will be pronounced regional and seasonal variability in the changes that are currently underway. The wind industry has been growing exponentially over the last decade, and is projected to expand and continue to play an ever-increasing role in electrical production around the world. Improved understanding of the resource, and in any inherent non-stationarities in the wind will help with transition to a sustainable energy future.

5. Reference

- Brock, F. V., Crawford, K. C., Elliott, R. L., Cuperus, G. W., Stadler, S., Johnson, H., and Eilts, M. (1997). The Oklahoma Mesonet: A technical overview. *Journal of Atmospheric and Oceanic Technology*, 12, pp. 5-19.
- Celik, A. N., (2003a). Assessing the suitability of wind speed probability distribution functions based on wind power density. *Renewable Energy* 28, pp.1563-1574.
- Celik, A. N., (2003b). A statistical analysis of wind power density based on the Weibull and Rayleigh models at the southern region of Turkey. *Renewable Energy* 29, pp.593-604.
- Conradsen, K., Nielsen, L. B., and Prahm, L. P. (1984). Review of Weibull statistics for estimation of wind speed distributions. *Journal of Climate and Applied Meteorology* 23, pp.1173-1183.
- Garcia-Bustamante, E., Gonzalez-Rouco, J. F., Jimenez, P. A., Navarro, J. and Montavez, J.P. (2008). The influence of the Weibull assumption in monthly wind energy estimation. *Wind Energy* 11, pp.483-502.
- Greene, J.S., M.L. Morrissey, and S. Johnson (2010). Wind Climatology, Climate Change, and Wind energy, *Geography Compass*, 4/11, 1592-1605.
- Hall, P., (1980). Estimating a density of the positive half line by the method of orthogonal series. *Annals of the Institute of Statistical Mathematics* 32, pp.351-362.
- Hayhoe, K., Cayan, D., Field, C. B., Frumhoff, E. P., Maurer, E. P., Miller, N. L., Moser, S. C., Schneider, S. H., Cahill, K. N., Cleland, E. E., Dale, L., Drapek, R., Hanemann, R. M., Kalkstein, L. S., Lenihan, J., Lunch, C. K., Neilson, R. P., Sheridan, S. C., and Verville, J. H., (2008). Emissions pathways, climate change, and impacts on California. *Proceeding of the National Academy of Sciences* 101, pp.12422-12427.
- Hayhoe, K., Wake, C., Anderson, B., Liang, X. L., Maurer, E., Zhu, J., Bradbury, J., DeGaetano, A., Stoner, A., and Wuebbles, D., (2008). *Regional Climate Change Projections for the Northeast USA. Mitigation and Adaption Strategies for Global Change*. DOI 10.1007/s11027-007-9133-2.
- Hennessey, J. P, Jr., (1977). Some aspects of wind power statistics. *Journal of Applied Meteorology*, 16, pp.63-70.
- Intergovernmental Panel on Climate Change, IPCC, (2007). *The Physical Science Basis, Fourth Assessment Report*.
- Izenman, A. J., (1991). Recent developments in nonparametric density estimation. *Journal of the American Statistical Association*, 86, pp.205-224.
- Jaramillo, O. A., and Borja, M. A., (2004). Wind speed analysis in La Ventosa, Mexico: A bimodal probability distribution case. *Renewable Energy* 29, pp.1613-1630.
- Juban, J., Siebert, N., Kariniotakis, G. (2007). Probabilistic short-term wind power forecasting for the optimal management of wind generation. Proceedings of PowerTech 2007 IEEE Conference, Lausanne, Switzerland.
- Justus, C. G., (1978). *Winds and wind system engineering*. Franklin Institute Press, Philadelphia, PA.
- Justus, C.G., and Mikhail, Amir. (1976). Height variation of wind speed and wind distribution statistics. *Geophysical Research Letters* 3, pp.261-264.
- Justus, C. G., Hargraves, W. R., Mikhail, Amir, and Graber, Denise. (1978). Methods for estimating wind speed frequency distributions. *Journal of Applied Meteorology* 17, pp.350-353.
- Koepl, G. W., (1982). *Putnam's Power from the Wind*. Von Nostrand, pp.470.

- Lackner, M. A., Rogers, A. L., Manwell, J. F., (2008). Uncertainty analysis in MCP-based wind resource assessment and energy production estimation. *J. Solar Energy Eng.* 130, doi: 10.1115/1.2931499.
- Liebscher, E., (1990). Hermite series estimators for probability densities. *Metrika* 37, pp.321-343.
- Li, M., and Li, X., (2005). MEP-type distribution function: A better alternative to Weibull function for wind speed distributions. *Renewable Energy* 30, pp.1221-1240.
- Luna, R. E. and Church, H. W. (1974) Estimation of Long-Term Concentrations Using a Universal Wind Speed Distribution. *Journal of Applied Meteorology* 13, pp.910-916.
- Monahan, A. H., (2006). The probability distribution of sea surface winds. Part II: Dataset intercomparison and seasonal variability. *Journal of Climate* 19, pp.521-534.
- Morrissey, M.L., Albers, A., J.S. Greene, and S.E Postawko (2010a), "An Isofactorial Change-of-Scale Model for the Wind Speed Probability Density Function", *Journal of Atmospheric and Oceanic Technology*, 27(2): 257-273.
- Morrissey, M.L., W.E. Cook, J.S. Greene (2010b), An Improved Method for Estimating the Wind Power Density Function, *Journal of Atmospheric and Oceanic Technology*, 27(7): 1153-1164.
- Najac, J. Boe, Julien and Terray, Laurent. (2009). A multi-model ensemble approach for assessment of climate change impact on surface winds in France. *Climate Dynamics* 32, pp.615-634.
- Pavia, E. G., and O'Brien, J. J. (1986). Weibull statistics of wind speed over the ocean. *Journal of Climate and Applied Meteorology* 25, pp.1324-1332.
- Pirazzoli, P. and Tomasin, A. (1990). Recent abatement of easterly winds in the northern Adriatic. *International Journal of Climatology* 19, pp.1205-1219.
- Ramirez, P. and Carta, J. A. (2005). Influence of the data sampling interval in the estimation of the parameters of the Weibull wind speed probability density distribution: a case study. *Energy Conservation and Management* 46. pp.2419-2438.
- Rehman, Shafiqur and Al-Abbad, Naif M. (2008). Wind shear coefficient, turbulence and wind power potential assessment for Dhulom, Saudi Arabia. *Renewable Energy* 33. pp.2653-2660.
- Sailor, D. J., Rosen, J. N., Hu, T., Li, X. (1999). A neural network approach to local downscaling of GCM output for assessing wind power implications of climate change. *Renewable Energy* 24. pp.235-43.
- Schoof, J. T. and Pryor, S.C. (2003). Evaluation of the NCEP-NCAR Reanalysis in terms of the synoptic-scale phenomena: A case study from the Midwestern USA. *International Journal of Climatology* 23. pp.1725-1741.
- Schwartz, M. and Elliott, D. (2006). *Wind shear characteristics at central plains tall towers*, NREL/CP-500-40019.
- Schwartz, S. C. (1967). Estimation of a probability density by an orthogonal series. *Annual Mathematical Statistics* 38. pp.1262-1265.
- Segal, M., Pan, Z., Arritt, R. W., and Takle, E.S. (2001). On the potential change in wind power over the US due to increases of atmospheric greenhouse gases. *Renewable Energy* 24. pp.235-243.
- Silverman, B. W. (1986). *Density Estimation*. London: Chapman and Hall.

- Stevens, M. J. M., Smulders, P. T. (1979). The estimation of the parameters of the Weibull wind speed distribution for wind energy utilization purposes. *Wind Energy* 3. pp.132-145.
- Stewart, D. A., and Essenwanger, O. M. (1978). Frequency distribution of wind speed near the surface. *Journal of Applied Meteorology* 17. pp.1633-1642.
- Tuller, S. E. (2004). Measured wind speed trends on the west coast of Canada. *International Journal of Climatology* 24. pp.1359-1374.
- Tuller, S. E., and Brett, A. C. (1984). The characteristics of wind velocity that favor the fitting of a Weibull distribution in wind speed analysis. *Journal of Climate and Applied Meteorology* 23. pp.124-134.
- Wackernagel, H. (2003). *Multivariate Geostatistics*. New York, NY: Springer.

Spatial Diversification of Wind Farms: System Reliability and Private Incentives

Christopher M. Worley and Daniel T. Kaffine
Colorado School of Mines
USA

1. Introduction

A growing literature suggests that intermittency issues associated with wind power can be reduced by spatially diversifying the location of wind farms. Locating wind farms at sites with less correlation in wind speeds smooths aggregate electricity generation produced by the multiple sites. However, technical studies focusing on optimal siting of wind farms to reduce volatility of total wind power produced have failed to address the underlying private incentives regarding spatial diversification by individual wind developers. This chapter makes a simple point: Individual wind developers will in general seek out the windiest sites for development, and as these locations are likely to be highly correlated in a given region, this pattern of development will tend to amplify (rather than smooth) problems associated with the variable nature of wind power. As such, private wind developers cannot be depended upon to provide reliability benefits from spatial diversification in the absence of additional incentives.

Wind power is growing rapidly in the United States and throughout the rest of the world. As concerns about global climate change intensify, policymakers and power utilities look to less carbon-intensive energy sources.¹ As a near-zero emission source of generation, wind provides a mature alternative technology with some of the most competitive renewable energy costs.² However, the potential for wind power to provide a substantial percentage of world electricity is hindered by the stochastic nature of the wind resource. Due to this intermittency, electricity from wind power cannot be dispatched like electricity from a coal boiler or a natural gas turbine. The day-to-day and hour-to-hour variability of wind power requires power utilities to maintain excess capacity of dispatchable electricity or face a potential shortfall when wind speeds diminish.

The capacity credit of wind power—the amount of dirty capacity that can be removed from the grid—is around 20% when wind power is initially added to the generation portfolio. In other

¹ The precise level of emissions avoided by wind power is a topic of much debate, and likely varies considerably with the existing generation mix, load levels, and other factors (Kaffine et al., 2011; Novan, 2010). The intermittency issues addressed in this chapter are in fact related to emission savings from wind power, as substantial variability in wind generation levels may require aggressive (emissions-intensive) ramping of thermal generation for load balancing.

² The Energy Information Administration Annual Energy Outlook 2011 (DOE/EIA-0383) gives U.S. national averages for the levelized costs of energy for different energy sources, including wind (\$97.0/MWh), conventional coal (\$94.8/MWh), solar PV (\$210.7/MWh), and solar thermal (\$311.8/MWh) under an assumed \$15 per metric ton of CO₂ emissions fee.

words, a wind farm with a nameplate capacity of 100 MW may only remove around 20 MW of dirty capacity. Furthermore, each additional marginal megawatt of wind capacity installed has a diminished ability to remove dirty generating capacity.³ If the aggregate supply of wind power were more reliable, then less backup generation capacity would be needed per MW of wind capacity. Thus, improving the reliability of wind power reaching the grid may provide economic benefits by allowing system operators and utilities to better schedule generation and reduce backup generation, not to mention the environmental benefits of reducing reliance on dirty generation.

Empirical work has shown that sites with high mean wind speed also have high variance in wind speeds.⁴ Given this, there are two ways that the variability of wind power produced by multiple wind farms may be reduced. First, wind farms could be built on sites with low variance. Unfortunately, wind developers have little incentive to build on sites with low wind speed variance because those sites also tend to have low mean wind speeds. The second method for reducing the variability of wind generation would be to diversify the supply of wind power over sites with low spatial correlation (an algorithm for determining the variance-minimizing locations for wind farms is presented in Choudhary et al. (2011)). Just as a diversified investment portfolio has less risk than investing in a single asset, a spatially-diversified portfolio of wind capacity could improve the reliability of wind power, reduce the risks of outage, and increase the capacity credit of wind power.

Kempton et al. (2010) examined offshore wind resources along the length of the Eastern Seaboard of the United States and found that wind speed correlations between sites dropped to 0.25 at around 500 km, implying that wind farms spread far apart could reduce the volatility of wind power reaching the electrical grid. Based on their simulation results, it may be socially beneficial if wind developers would hedge the unreliability of wind power by developing wind power at spatially disparate sites with less correlated wind speeds. Kempton et al. (2010) note that such a system may prove to be difficult to develop because electricity generation is largely a state-level concern, and it may be difficult to align the incentives of the many states required for a system of interconnected wind farms along the Eastern Seaboard. In the particular case of the Eastern Seaboard, achieving such a spatial diversification of wind farms would require the input and cooperation of four electricity reliability councils, the public utilities commissions of fifteen states, dozens of power companies, and many, many individual wind developers.

In fact, the role of locational investment incentives may be even more important at the individual firm level. Roughly 80% of wind farms are independent power producers (IPP), which are not owned or operated by power utilities.⁵ These wind developers search for windy sites on which to build, and then negotiate a Power Purchase Agreement (PPA) with the utility to lock in a fixed rate for electricity sales. These independent wind developers are motivated purely by the private cost-benefit analysis of site development, so they hunt for “jackpot” sites with the greatest return (typically the very windiest sites with correspondingly high variance). Furthermore, wind farms in a region are likely to be closely co-located in space because meteorological wind speeds are spatially correlated. As a result, individual wind

³ A technical report from the National Renewable Energy Laboratory summarizes capacity credit estimates from around the U.S., which tend to fall in the 5-35% range (Milligan & Porter, 2008).

⁴ As such, one potential model for wind speeds is a Weibull or Rayleigh distribution. Beenstock (1995) argues that a Rayleigh distribution is a useful assumption that is a good baseline approximation of the true wind distribution.

⁵ This estimate comes from interviews with wind researchers and wind industry professionals.

developers are unlikely to ultimately build on sites that enhance the reliability of the total supply of wind generation.

To illustrate the central point of this chapter, we first develop a simple theoretical model to compare the optimal siting decisions of individual wind developers versus the optimal siting decisions of system operators.⁶ Given a 1-dimensional region with a concave distribution of wind speeds, all individual wind developers will choose to build as close to the wind speed maximum as possible. As such, wind speeds at these wind farms will be highly correlated and thus aggregate wind generation will be highly volatile. In contrast, the system operator will trade off the benefits of generating electricity at the windiest site for a more reliable supply of wind power, spreading out wind farms farther from the location of the wind speed maximum. To provide further economic intuition, we present a closed-form analytical solution for siting decisions that can be generalized for up to n wind farms.

To highlight the divergence of incentives between decentralized wind developers and the system operator, we develop a spatial optimization model, loosely calibrated to the plains of eastern Colorado, whereby agents maximize profit by choosing a number of locations for wind farms. In the case of individual, decentralized wind developers, each firm maximizes their expected private returns by selecting the most profitable site for development, given wind speed of known mean and variance. On the other hand, for the case of the system operator, a single agent selects locations that maximize expected total returns from development and includes costs associated with the reliability of aggregate wind power reaching the grid. The model generates Rayleigh-distributed, correlated wind speeds for each site over a lengthy time horizon. Importantly, wind speed correlation between sites declines over distance and we allow for differing mean wind speeds for each site. Both the individual wind developers and system operator select the location that maximizes their objective functions based on the generated wind speeds.

There is a significant divergence between the optimal locational decisions of the individual wind developers and the system operator. Individual wind developers choose to build on the windiest sites, and as wind power produced at those sites is highly correlated, high reliability costs are incurred. By contrast, the system operator internalizes the tradeoffs between system reliability generated by diversified siting decisions and the profits associated with the windiest sites, resulting in more spatially diverse locations being selected and an improvement in reliability and total economic value. We note that providing the correct siting incentives to individual wind developers will require those incentives to be conditioned on the siting decisions by all other wind developers, and we finish this chapter with some concluding remarks and suggestions for further work.

⁶ There are many parties that may receive benefits from wind reliability, including Independent System Operators (ISO) responsible for load balancing, or rate payers who ultimately pay the cost of maintaining backup generation, or public utilities who must ramp their thermal generation units for load balancing. We use the 'system operator' as a catch-all for all such parties that receive reliability benefits (in addition to economic returns from generation) and would therefore internalize these benefits into their optimal decisions regarding wind farm location. We also recognize that the economic incentives of real-world system operators may not precisely match those of the economic agent that we have dubbed the 'system operator' in the analysis below. Ultimately we are interested in comparing the siting decisions of individual wind developers interested in purely private profits versus an economic agent with a more systemic outlook, concerned with system profits including benefits and costs associated with system reliability. Determining the distribution of the costs and benefits of reliability to the various parties is outside the scope of this study.

2. Background

The electricity and wind engineering literatures have analyzed the role of wind farm locations in electrical grid reliability as far back as Kahn (1979), who first notes that the variance of wind power output decreases as the geographic distance between wind farms increases. Since then, much work has been done to analyze this issue at many scales. Cassola et al. (2008) proposes a procedure for minimizing wind power variance through optimal siting of wind farms over the island of Corsica, which is slightly smaller than the State of Delaware. Milligan & Artig (1999) analyzes potential wind sites in Minnesota, while Milligan & Factor (2000) analyzes sites in Iowa and find that state-level diversification allows power utilities to reduce wind power supply risk. Archer & Jacobson (2007) select nineteen sites in four mid- and southwestern states (i.e., Kansas, Oklahoma, Texas, and New Mexico) and find results similar to those of previous studies, mainly that reliability benefits increase with distance between wind farms and reduced variability translates into fewer high and low wind events. Choudhary et al. (2011) develop a variance-minimizing algorithm for wind farm additions in Oklahoma, and find that the algorithm will select the site that is geographically most distant from existing stations. Kempton et al. (2010) used five years of wind data from eleven offshore sites along the Eastern Seaboard of the United States to test the reliability benefits of spatially diversifying wind farms on a synoptic-scale, meaning that they test reliability with respect to differing pressure patterns at distances of 1,000 km or greater. They find that such a system experienced few periods of complete power outage or full capacity, and power levels changed slowly over time.

While all of these studies show that there are reliability benefits of spatially diversified wind farms (in terms of reducing power variance), they fail to address how the incentives of wind power developers may affect reliability. In fact, this issue has been overlooked by the economics literature as well. To remedy this, we present a spatial optimization model that simulates the differing locational incentives of wind power players. Spatial optimization models have been broadly used for many types of land-use issues like optimal managing of timber harvests with wildlife habitats (Hof & Joyce, 1992), the trade-offs of biodiversity and land-use for economic returns (Kagan et al., 2008), and efficient utilization of urban areas (Ligmann-Zielinska et al., 2008) among other types of problems. Before simulating the decisions of wind power developers, we develop an analytical model to better understand the intuition behind locational investment decisions.

3. Analytical model

How might we illustrate the differing incentives of private wind developers and a system operator? We develop a simple analytical exercise that captures the spatial variation in wind speeds and corresponding impacts on reliability.⁷ Let wind speed v be distributed over a 1-dimensional space $(-\infty, \infty)$ given by the concave function $v(x)$ where the maximum windspeed v_{max} is located at the origin $x = 0$. At a given site x , wind can be converted into electricity (kWh) as represented by the function $W(v(x))$ (where $W_v > 0$). Each of two individual wind developers will chose their privately optimal wind farm location (x_1 and x_2) that maximizes this objective:

$$\max_{x_i} \pi = pW(v(x_i)) - F \quad \forall i = 1, 2 \quad (1)$$

⁷ In the spirit of using the simplest possible model to make an analytical point, much of the real-world complexity of siting decisions have been stripped out.

where p is the per-unit price of electricity (\$/kWh) and F is the fixed cost (\$) of operating the wind farm over the time horizon. The first-order conditions for building wind farms x_1 and x_2 are given as:

$$\pi_{x_i} = p \frac{dW}{dv} \frac{dv}{dx_i} = 0 \quad \forall i = 1, 2 \tag{2}$$

Because $v(0) = v_{max}$, the location that maximizes profit for both wind developers exists at the maximum of the wind speed distribution, such that $x_i^* = 0, \forall i = 1, 2$. Thus, when the wind developers choose wind farm locations based on their private incentives, both wind farms will be built as close as possible to the point with the highest mean wind speed. Due to their proximity, wind speeds at these sites will be highly correlated, resulting in a supply of wind power that is less reliable than had the two sites been located farther apart. Thus, any benefits from spatial diversification are not realized under this setting where individual wind developers select locations for wind development.

By contrast, the system operator internalizes the reliability benefits of spatial diversification when locating wind farms. These reliability benefits will be simply expressed by the function $r(d)$ (where $r_d > 0$), such that the distance between wind farms is given as $d = x_2 - x_1$. The system operator’s optimization problem is given as the joint maximization of profits from locating two wind farms plus reliability benefits from spatial diversification:

$$\max_{x_1, x_2} \pi = [pW(v(x_1)) - F] + [pW(v(x_2)) - F] + r(d) \tag{3}$$

Given this objective, the first-order conditions are as follows:

$$\begin{aligned} \pi_{x_1} &= p \frac{dW}{dv} \frac{dv}{dx_1} - r'(d) = 0 \\ \pi_{x_2} &= p \frac{dW}{dv} \frac{dv}{dx_2} + r'(d) = 0 \end{aligned} \tag{4}$$

Given positive benefits of spatial diversification ($r_d > 0$) and comparing against the decentralized first-order conditions in equation 2, the system operator will choose to build on either side of $x = 0$ (where $v(x) < v_{max}$). Relative to the case of individual wind developers, the system operator will spread the wind farms farther apart ($x_2 - x_1 > 0$) as long as there are positive marginal benefits from spatial diversification, $r_d > 0$. While wind speeds are slower and less power is produced at locations away from the location corresponding to v_{max} , the system operator offsets those power losses with the gains from a more reliable supply of wind power.

These results can be generalized to the case of multiple wind farms. Individual wind developers will choose to build all wind farms as close to v_{max} as possible ($x_i^* = 0, \forall i = 1, \dots, n$). On the other hand, the system operator realizes reliability benefits depending on the pairwise distances between wind farms, $r(d_{ij})$.⁸ The system operator’s objective function when choosing to develop three sites is given as the following:

⁸ More formal and realistic treatments of how reliability benefits might enter the system operator’s objective function are certainly possible, though the basic intuition outlined below will still hold. For simplicity, we will assume $r'(d_{ij}) = r'(d)$.

$$\begin{aligned} \max_{x_1, x_2, x_3} \pi = & [pW(v(x_1)) - F] + [pW(v(x_2)) - F] + [pW(v(x_3)) - F] \\ & + r(x_3 - x_2) + r(x_3 - x_1) + r(x_2 - x_1) \end{aligned} \quad (5)$$

Given this objective, the first-order conditions are given as:

$$\pi_{x_1} = p \frac{dW}{dv} \frac{dv}{dx_1} - 2r'(d) = 0, \quad \pi_{x_2} = p \frac{dW}{dv} \frac{dv}{dx_2} = 0, \quad \pi_{x_3} = p \frac{dW}{dv} \frac{dv}{dx_3} + 2r'(d) = 0 \quad (6)$$

where the system operator locates one wind farm at the origin, and the remaining two wind farms on either side of the origin.

A closed-form solution of the optimal development locations cannot be obtained without some assumptions on the parametric forms of the spatial distribution of wind, wind power production function, and reliability benefits of spatial separation between sites. Supposing $v(x) = v_{max} - bx^2$, $W(v) = \gamma v$, and $r'(d) = \bar{r}$ we arrive at the system operator solution for the two wind farm case:⁹

$$x_1^* = -\frac{\bar{r}}{2p\gamma b'}, \quad x_2^* = \frac{\bar{r}}{2p\gamma b'} \quad (7)$$

and the three wind farm case:

$$x_1^* = -\frac{\bar{r}}{p\gamma b'}, \quad x_2^* = 0, \quad x_3^* = \frac{\bar{r}}{p\gamma b'} \quad (8)$$

These closed-form solutions yield some intuitive comparative statics that illustrate the tradeoffs that the system operator faces. As the benefits from spatial diversification, \bar{r} , increase, the wind farms will be located further away from v_{max} . By contrast, as the price of electricity p increases, the system operator will value the profitable generation associated with high wind speeds near v_{max} relative to the reliability benefits. As a result, they will build closer to v_{max} . In fact, an increase in any parameter in the denominator will shift the optimal wind farm sites for the system operator closer to $x = 0$. The parameter b captures the curvature of the spatial distribution of wind speed. As this parameter increases, the curvature of the wind speed distribution becomes steeper, further reducing the wind speed at sites away from the origin and pushing development towards $x = 0$ and v_{max} . Finally, the parameter γ describes the efficiency of the wind turbines for producing electricity. When γ increases, turbines become more efficient at producing power, and the reliability benefits of spatial diversification become less valuable than building closer to the higher wind speeds located at $x = 0$.

These results can be extended to the case of n wind farms as given in table 1. In short, for an even number of wind farms, the system operator will build matching wind farms equidistant on either side of $x = 0$. For an odd number of wind farms, the system operator will build one wind farm on $x = 0$, and build matching pairs of wind farms further and further away from v_{max} . By contrast, the individual wind developers will build as close to $x = 0$ as physically possible.

⁹ As noted in Beenstock (1995), electricity is generated as a cubic function of the wind speed. While the linear function $W(v) = \gamma v$ fails to capture real-world characteristics of wind, this assumption allows us to find a closed-form solution.

Number of wind farms	1	2	3	4	5	...	n
Individual developer locations							
Wind farm 1 . . . n	0	0	0	0	0	...	0
System operator locations							
Wind farm 1	0	$-\frac{\bar{r}}{2p\gamma b}$	$-\frac{\bar{r}}{p\gamma b}$	$-\frac{3\bar{r}}{2p\gamma b}$	$-\frac{2\bar{r}}{p\gamma b}$...	$-\frac{(n-1)\bar{r}}{2p\gamma b}$
Wind farm 2	-	$+\frac{\bar{r}}{2p\gamma b}$	0	$-\frac{\bar{r}}{2p\gamma b}$	$-\frac{\bar{r}}{p\gamma b}$...	$-\frac{(n-3)\bar{r}}{2p\gamma b}$
Wind farm 3	-	-	$+\frac{\bar{r}}{p\gamma b}$	$+\frac{\bar{r}}{2p\gamma b}$	0	...	$-\frac{(n-5)\bar{r}}{2p\gamma b}$
Wind farm 4	-	-	-	$+\frac{3\bar{r}}{2p\gamma b}$	$+\frac{\bar{r}}{p\gamma b}$
Wind farm 5	-	-	-	-	$+\frac{2\bar{r}}{p\gamma b}$
...
Wind farm n - 1	-	-	-	-	-	...	$+\frac{(n-3)\bar{r}}{2p\gamma b}$
Wind farm n	-	-	-	-	-	...	$+\frac{(n-1)\bar{r}}{2p\gamma b}$

Table 1. Optimal wind farm location decisions for individual wind developer and the system operator

This analytical model is a very simplified version of the real-world spatial incentives of wind development. In the next section, we design a numerical simulation model that is multidimensional, has stochastic and spatially-correlated wind speeds, and features a more realistic power curve. Calibrating the simulation model to real-world parameters allows us to capture the relative scale of the trade-offs involved.

4. Simulation model

To highlight the differing incentives of individual wind developers and the system operator, we next develop a spatial optimization model. As in the previous section, we will be comparing the optimal siting decisions of individual wind developers with those of the system operator. The physical space is a 3-x-3 grid of $n = 9$ potential sites for development with wind speeds of known mean and variance. We generate Rayleigh-distributed, spatially-correlated random wind speeds for each site over 1,000 days (with one random draw per day), allowing differing mean wind speeds for each site.¹⁰ The windiest sites are located near each other (see figure 1(a)), and the wind speed correlation between sites declines with the pairwise distance between sites (see figure 1(b)).

We very loosely calibrate the model to the northeastern plains region of the State of Colorado, a windy part of the state with some wind development. Each of the sites in figure 1(a) would be 100 km on each side, meaning that the nine sites would roughly cover an area from the northeastern corner of the state to Colorado Springs (roughly located in the center of the state). The U.S. Department of Energy provides state level wind maps, showing that Colorado has windy locations along the eastern border with Nebraska, Kansas, and Oklahoma.¹¹ The general pattern of wind speeds from these state level wind maps provide the basis for the mean wind speed distribution across the nine sites in the model. Site 9 is the windiest

¹⁰ The procedure for generating Rayleigh-distributed, spatially correlated wind speeds is adapted from Natarajan et al. (2000) and Tran et al. (2005)

¹¹ The DOE Office of Energy Efficiency & Renewable Energy maintains a website that provides maps of wind resource potential at 80 meter heights (http://www.windpoweringamerica.gov/wind_maps.asp Accessed 2/18/2011).

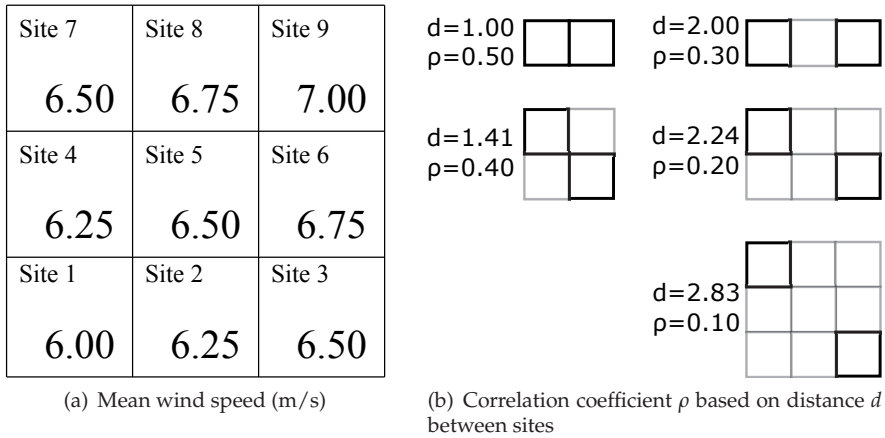

Fig. 1. Mean wind speed and pairwise correlations for 3x3 scenarios

site with wind speeds decreasing with distance from Site 9, meaning that Site 1 is the least windy location. We generate wind speed correlations between sites that decay over distance in the spirit of Kempton et al. (2010, Fig. 2). We stress that the quantitative results below are primarily illustrative, with the primary insights of the simulation model arising from the qualitative comparison of the siting decisions made by individual wind developers versus the system operator.

4.1 Individual wind developer model

We begin by simulating two wind farm developers each choosing the site $(1, \dots, n)$ that maximizes their expected profit over the time horizon, $T = 1000$. As in the analytical model developed above, individual wind developers are only interested in the private economic return from developing a given site for wind power. Each wind developer i has an identical objective function:

$$\max_{X_i} \pi = \sum_{i=1}^n \sum_{t=1}^T p k_{it} X_i - \sum_{i=1}^n c_i X_i \tag{9}$$

The binary choice variable, X_i , equals 1 when the developer builds a wind farm on site i and 0 otherwise, and a developer cannot build on a site that has already been built upon by the other developer.¹² The parameter p is the price of electricity, which we assume to be \$0.10.¹³ We assume that the fixed costs of operating a wind farm, c_i , are equal at all sites, which we estimate to be \$557,160 over the 1,000 day time horizon.¹⁴ The variable k_{it} is the

¹² The size of the wind farm (i.e., the number of turbines) arbitrarily affects the model, only scaling the magnitude of each scenario’s profit and power produced. While one could simulate 10, 20, or 100 turbines, we simplify the model by assuming that each wind farm consists of one turbine.

¹³ A value close in scale to estimates in the Energy Information Administration Annual Electric Power Industry Report (Form EIA-861).

¹⁴ This is based on estimates from Elkinton et al. (2006) that annualized fixed costs plus yearly variable costs of 3.7 cents/kWh - 5.5 cents/kWh. We choose levelized production costs of 6.0 cents/kWh. Given that the mean power produced at Site 9 at any given time is 9,286 kW, we arrive at a fixed cost of \$557,160 over the 1,000 day time horizon. This is held constant over all sites even though the levelized production costs may differ for sites with slower mean wind speeds.

generation (in kWh) at site i in time period t . This is calculated from the spatially-correlated Rayleigh-distributed randomly drawn wind speeds v_{it} via the following power function:

$$k_{it} = \begin{cases} 0 & \text{if } 0 \leq v_{it} < 4 \\ \lambda \cdot v_{it}^3 & \text{if } 4 \leq v_{it} < 11 \\ \lambda \cdot (11)^3 & \text{if } 11 \leq v_{it} \leq 25 \\ 0 & \text{if } v_{it} > 25 \end{cases} \quad (10)$$

The parameter λ is the power proportionality constant that converts wind speeds in m/s to electricity generation in kWh.¹⁵ Wind turbines are able to generate electricity only over certain wind speeds. No electricity can be generated for wind speeds below 4 m/s as the wind is too slow. For wind speeds above 4 m/s, electricity is proportional to the cube of wind speed, topping out at 11 m/s. Constant generation is produced for windspeeds between 11 - 25 m/s, and for speeds above 25 m/s, turbines are shut down for fear of damage. Each developer is constrained to build on only one site:

$$\sum_{i=1}^n X_i \leq 1 \quad (11)$$

Thus, given a draw of 1,000 Rayleigh-distributed, spatially correlated wind speeds v_{it} at each site i for each period t , each wind developer selects the site for development that maximizes private profits.

4.2 System operator model

The system operator chooses the location of two wind farms by balancing the high revenues associated with concentrating development at windier sites with the reliability cost of spatial diversification. The objective function looks similar to that of individual wind developers except for the addition of the reliability cost variable, R_t , in each time period t . The system operator incurs a nonnegative reliability cost (in dollars) for each time period when the system supply of wind power is less than the expected level.¹⁶ The system operator’s objective function is as follows:

$$\max_{X_1, X_2} \pi = \sum_{i=1}^n \sum_{t=1}^T p k_{it} X_i - \sum_{i=1}^n c_i X_i - \sum_{t=1}^T R_t \quad (12)$$

The system operator is constrained to build on two sites:

$$\sum_{i=1}^n X_i \leq 2 \quad (13)$$

¹⁵ For an assumed 1.5 MW wind turbine rated at 11 m/s, the power proportionality constant is equal to 1128 (found by simply dividing 1,500,000 by 11³)

¹⁶ Thus, reliability costs are incurred when the sum of wind power from the two wind farms falls below expected levels. It should be noted that we are only considering the reliability costs associated with a shortfall in wind generation. However, it may also be the case that a temporary overabundance of wind generation can also be problematic from the perspective of the system operator. For example, large amounts of wind power reaching the grid may require sudden and costly curtailment of other generation sources, which then have to be ramped back online when wind power diminishes. Including such considerations would further sharpen the contrast between the incentives of individual wind developers and the reliability-internalizing system operator.

The system operator model has two additional constraints that define and ensure nonnegativity of the reliability cost. This first constraint calculates the value of the reliability cost, which we conceptualize as the cost of maintaining backup generating capacity or purchasing electricity on the wholesale market when a wind farm's generation k_{it} does not meet the mean generation level \bar{k}_i .¹⁷ The parameter z is the per-unit reliability cost, which we set at \$0.10.¹⁸ The difference $\sum_{i=1}^n (\bar{k}_i - k_{it})X_i$ is the system power shortage in period t . The parameter M is an arbitrarily large number and the binary variable β_t is equal to 1 when there is a system shortage of wind power and equal to 0 otherwise.¹⁹

$$R_t \geq z \cdot \sum_{i=1}^n (\bar{k}_i - k_{it})X_i - M(1 - \beta_t) \quad \forall t \quad (14)$$

This second constraint forces the reliability cost to be zero when $k_{it} > \bar{k}_i$.

$$\sum_{i=1}^n k_{it} \cdot X_i \geq \sum_{i=1}^n \bar{k}_i \cdot X_i - \beta_t \cdot M \quad \forall t \quad (15)$$

The system operator problem is solved by jointly selecting the two best sites, accounting for the benefits from spatial diversification.

4.3 Results

Before discussing the optimization results, we begin with a cursory examination of wind power produced from randomly generated, Rayleigh-distributed, spatially correlated wind speeds at sites with varying levels of spatial diversification. Figure 2 compares the capacity factor of two wind farms over a horizon of 100 time periods for three different groupings of the two wind farms.²⁰ We wish to compare the variability in power supplied when there are two wind farms located on Site 3, one on Site 3 and one on Site 5, and one on Site 3 and one on Site 7. Visual comparison in figure 2 of the joint capacity factor across groupings is somewhat difficult, but there are fewer dramatic peaks when wind farms are spatially diversified in figure 2(c) compared to when wind farms are co-located in figure 2(a). This suggests that the volatility of wind supply from wind farms on Sites 3 and 7 is less than that of two wind farms co-located on Site 3.

As noted in figure 1(b), these three sites have the same mean wind speed and variance, but when wind farms are located at less spatially correlated sites, there is a reduction in the total variance of total power produced. For two wind farms co-located on Site 3, the sample variance in capacity factor is 0.093. The sample variance decreases as the wind farms are located farther apart. For wind farms on Sites 3 and 5, the sample variance is 0.076, and for Sites 3 and 7, the sample variance is 0.061.

¹⁷ As noted previously, this is a simplification of the cost imposed on the utility when they have an unreliable source of power, but it allows for a tractable solution with easily interpretable results.

¹⁸ We believe this to be a reasonable cost, as this might be the price that a utility pays for electricity on the spot market or for natural gas backup generation.

¹⁹ The variable β and the parameter M are used in these constraints to ensure nonnegativity of the reliability cost as is consistent with "Big-M" formulations.

²⁰ Capacity factor is the percentage of nameplate capacity that a turbine produces at a given point in time. For example, a 2 MW turbine operating with a capacity factor of 0.6 would produce 1.2 MW of electricity.

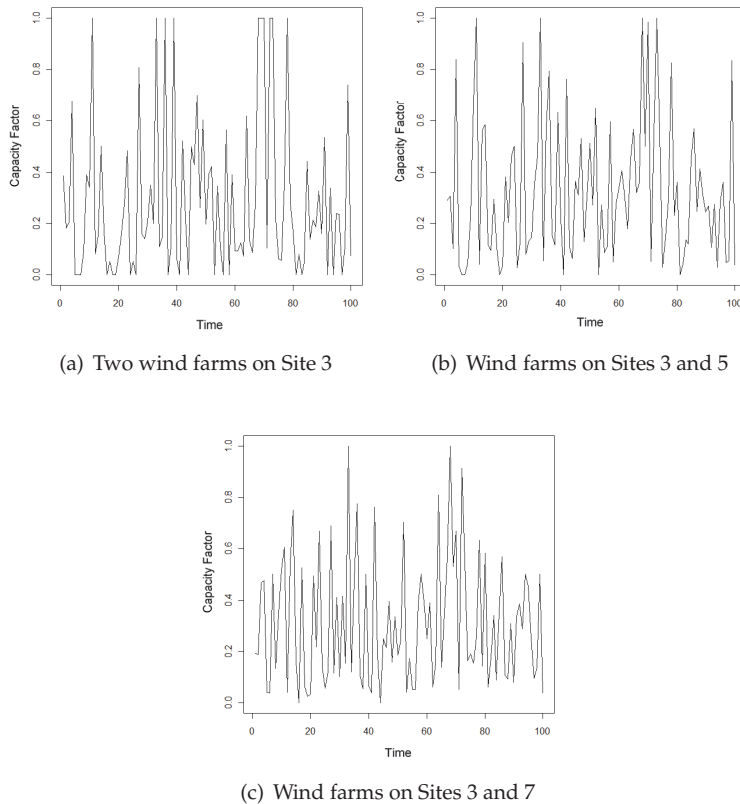

Fig. 2. Capacity factor of two wind farms

As theory suggests, spatial diversification reduces the volatility of the supply of wind power. But how do agents respond to these diversification incentives? We run the optimization model over the 1,000 day time horizon with daily random wind speed draws for each site and determine the optimal siting decisions of individual wind developers and a system operator. However, the locations chosen represents the optimum for a specific set of 1,000 day random draws. To get a better sense of the incentives as play, the model itself is simulated over 1,000 runs, with the optimal decisions for each run recorded and reported in distribution form below.

As discussed in the analytical model, because individual wind developers do not receive any benefits from spatial diversification, they will look to develop on the sites with the highest expected electricity production (and therefore profits). The simulated optimal siting decisions for the individual wind developers are shown in figure 3.

As the model is run 1,000 times, the results in (figure 3(a)) give the number of times out of 1,000 that site was selected for a wind farm by the individual wind developers. As suggested in the analytical model, most wind development is clustered around the site with the highest mean wind speed, Site 9. Sites 6 and 8 are the next windiest sites and are selected the next greatest

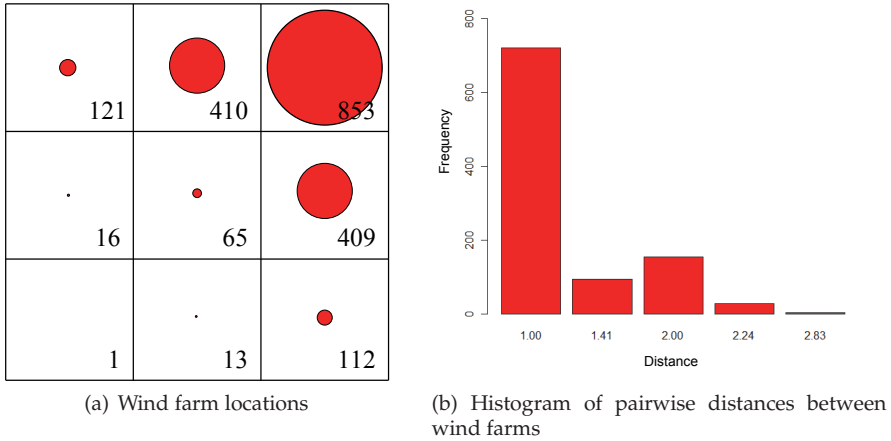

Fig. 3. Individual wind developers location results

number of times. The pairwise distance between wind farms is calculated for each run, and, as expected, most wind farms built by individual developers are built a single unit apart (figure 3(b)). Thus, individual wind developers are typically selecting the jackpot outcome in the northeast corner of the grid and are not spatially diversifying wind farms.

In contrast to individual wind developers, the system operator benefits from higher wind speeds but also incurs the costs of any demand shortfall should the wind not blow. The system operator maximizes profit by jointly considering windy sites and the benefits from a more reliable wind portfolio. We again present the results of the simulation model as a distribution of optimal siting decisions and a histogram of the pairwise distance between wind farms for each run (figure 4).

In contrast to the locations chosen by individual wind developers, the system operator chooses to develop sites all around the map (figure 4(a)). In particular, locations near the center of the grid (Site 5) are eschewed in favor of more spatially disparate sites due to the reliability benefits from less correlated wind speeds. The histogram makes this point even more clear (figure 4(b)), as the most common pairwise distance between sites is 2.24 units (Sites 6 and 7 for example - the equivalent of a 'knight-move' in chess), followed by the maximum distance of 2.83 units (Sites 3 and 7 or Sites 1 and 9, corresponding to the corners). The system operator is willing to choose sites with lower mean wind speed due to the benefits of a reliable supply of wind power.

In addition to the differences between the optimal siting decisions of individual wind developers and the system operator, system profits and total power produced differ as well.²¹ Table 2 lists total power and system profit results for the individual wind developer and system operator scenarios averaged over the 1,000 simulated runs. Noting again that the quantitative values are subject to the various parameter assumptions, we focus on the

²¹ We define system profit as total revenue - fixed costs - reliability cost, ignoring which party actually receives the revenues and costs in each scenario. The total power shortage is defined as the sum of power shortages at both wind farm over all time periods.

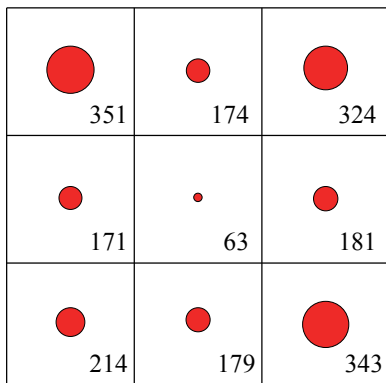

(a) Wind farm locations

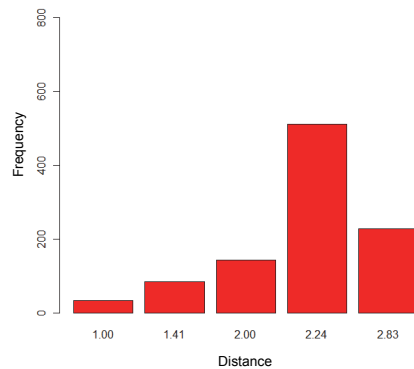

(b) Histogram of pairwise distances between wind farms

Fig. 4. System operator location results

relative differences between the two scenarios. Most notably, the reliability cost is reduced by 27% under the system operator scenario as compared to the individual wind developer scenario, reflecting the less volatile wind supply at sites chosen by the system operator. Correspondingly, the locations selected by the system operator reduce total power shortage by 15% relative to the sites selected by individual wind developers. As the system operator internalizes reliability costs when selecting sites, total system profit increases by 8% under the system operator scenario relative to the individual wind developer scenario. However, by trading off windier sites for a more reliable supply of power, the total power produced decreases under the system operator, but only by about 2%.

Scenario	System Profit (\$)	Reliability Cost (\$)	Total Power Produced (kWh)	Total Power Shortage (kWh)
Individual wind developers	942,542	481,740	25,385,700	6,278,120
System operator	1,015,220	350,656	24,801,600	5,344,600

Table 2. System profits, reliability costs and power results

These results show that while individual wind developers are privately better off when they choose the windiest sites for development, they pass along large reliability costs as an externality that is directly borne by the system operator (or other economic agents). By contrast, the system operator trades off the benefits of high wind speed sites for a reliable portfolio of sites, resulting in an increase in system profit and only a minor decrease in total power produced.²²

²² To the extent that wind power offsets emissions-intensive forms of generation, changes in total power produced may also have economic efficiency implications. However, in this particular case, the extra power production under the individual wind developer scenario comes at the substantial cost of 12 cents of system profit per additional kWh of generation.

5. Discussion

We conclude with a discussion of how incentives may be structured to encourage individual wind developers to appropriately internalize reliability costs. We also discuss how additional factors omitted from the above analysis might affect spatial diversification and end with some concluding remarks and directions for future work.

5.1 Incentives for individual wind developers to spatially diversify

While spatially-diversified wind farms may generate reliability benefits, if individual wind developers do not receive those benefits, their locational decisions for development will not internalize these benefits and the total supply of wind power will be less reliable. Creating incentives for individual wind developers to internalize their reliability effects and spatially diversify would likely take two forms: price premiums or penalties. First, site-specific deterministic prices could be built into PPA's, whereby a relative price premium would be attached to sites that improve reliability. Second, some form of deterministic or stochastic penalty could be levied conditional on the generation level produced by individual wind developers.

Whatever form these incentives take, they must be set conditionally with respect to the locations and spatial correlations of all other wind farms. So for a deterministic site-specific pricing system, the price paid for development at a given site would have to appropriately internalize the marginal impact of an additional wind farm on system reliability. For a penalty system, the penalty applied to an individual farm would need to be tied to systemic shortfalls in generation from *all* wind farms to generate the correct incentives to spatially diversify.²³ By contrast, a flat wind integration charge, such as the 0.6 cents per kWh charge imposed by the Bonneville Power Authority (BPA) (Choudhary et al., 2011), will not provide any incentive for an individual wind farm to spatially diversify and choose a location that improves system reliability.²⁴

5.2 Additional factors affecting locational decisions

The preceding analysis explored the optimal siting incentives of individual wind developers versus the system operator. Locational incentives were driven by differences in mean wind speeds and spatial correlations between sites. However, factors such as access to transmission lines and interactions between wind farms also play a role in siting decisions. In particular, transmissions costs and constraints are likely to generate additional incentives for spatial clustering of wind farms as individual wind farms minimize any private costs incurred with transmission. By contrast, wake effects between wind farms (Kaffine & Worley, 2010) may lead to some spatial diversification by individual wind farms, however the scale of wake

²³ See Worley (2011) for a further exploration of different penalty structures and the corresponding impacts on locational decisions and system profit, reliability and power. In particular, Worley (2011) finds that a penalty leveled on individual wind developers when aggregate wind generation levels fall below a threshold power level will provide individual wind developers the correct incentives to spatially diversify like the system operator. Despite the theoretical appeal of a penalty system that generates individual penalties based on system performance, such a penalty scheme may be difficult to implement. A penalty scheme of this nature is similar to ambient pollution taxes (Segerson, 1988) which have appealing theoretical properties but have not been frequently employed.

²⁴ Note that we are not commenting on the wisdom of such a charge as there are obviously other reasons for imposing such charges (such as cost-recovery). We simply mention it as an example of a penalty scheme that would not provide incentives for spatial diversification.

effects (5-20 km) is likely too small relative to the large scale required for reducing system volatility.

5.3 Concluding remarks

Our results show that individual wind developers choose sites with the highest mean wind speed, while the system operator will trade off the increased revenue of windy sites for a more reliable wind supply. Because wind speeds are correlated over space, individual wind developers in a given region will choose to build on windy sites that are likely to be closely located to one another. By contrast, the distance between wind farms built by the system operator is likely to be larger in order to capture the benefits of a reliable supply of wind power from less correlated wind farms.

These results raise further questions about the reliability benefits of spatial diversification. Further work could be done to estimate the magnitude of reliability benefits (or equivalently, the costs of intermittency), or to estimate the effect of serially-correlated, hourly wind speeds on reliability benefits. Additionally, work could be done to more accurately calibrate the simulation model to the real world using historical wind speed data and installed wind capacity for a given region. Using this information, it would be possible to choose locations that provide the most reliability benefits to the electrical grid (Choudhary et al., 2011) while balancing generation and revenue considerations. Finally, another avenue of research might examine the effect of reliability incentives on intensive and extensive margins of investment in wind development. Internalizing the costs of reliability will decrease the private profitability of wind power and reduce overall wind development, which may be in conflict with other policy objectives.

6. References

- Archer, C. L. & Jacobson, M. Z. (2007). Supplying baseload power and reducing transmission requirements by interconnecting wind farms, *Journal of Applied Meteorology and Climatology* 46: 1701–1717.
- Beenstock, M. (1995). The stochastic economics of windpower, *Energy Economics* 17(1): 27–37.
- Cassola, F., Burlando, M., Antonelli, M. & Ratto, C. (2008). Optimization of the regional spatial distribution of wind power plants to minimize the variability of wind energy input into power supply systems, *Journal of Applied Meteorology and Climatology* 47: 3099–3116.
- Choudhary, P., Blumsack, S. & Young, G. (2011). Comparing decision rules for siting interconnected wind farms, *Proceedings of the 44th Hawaii International Conferences on System Sciences*, hicc, pp. 1–10.
- Elkinton, C. N., Manwell, J. F. & McGowan, J. G. (2006). Offshore wind farm layout optimization (owflo) project: Preliminary results, 44th AIAA Aerospace Sciences Meeting and Exhibit.
- Hof, J. G. & Joyce, L. A. (1992). Spatial optimization for wildlife and timber in managed forest ecosystems, *Forest Science* 38(3): 489–508.
- Kaffine, D., McBee, B. & Lieskovsky, J. (2011). Emissions savings from wind power generation: Evidence from texas, california and the upper midwest, *Working paper*.
- Kaffine, D. T. & Worley, C. M. (2010). The windy commons?, *Environmental and Resource Economics* 47(2): 151–172.
- Kagan, J., Starfield, A. & Tobalske, C. (2008). Where to put things? Spatial land management to sustain biodiversity and economic returns, *Biological Conservation* 141: 1505–1524.

- Kahn, E. (1979). Reliability of distributed wind generators, *Electric Power Systems Research* 2(1): 1–17.
- Kempton, W., Pimenta, F., Veron, D. & Colle, B. (2010). Electric power from offshore wind via synoptic-scale interconnection, *Proceedings of the National Academy of Sciences* 107(16): 7240–7245.
- Ligmann-Zielinska, A., Church, R. & Jankowski, P. (2008). Spatial optimization as a generative technique for sustainable multiobjective land-use allocation, *International Journal of Geographical Information Science* 22(6): 601–622.
- Milligan, M. R. & Artig, R. (1999). Choosing wind power plant locations and sizes based on electric reliability measures using multiple year wind speed measurements, *Technical report*, National Renewable Energy Laboratory.
- Milligan, M. R. & Factor, T. (2000). Optimizing the geographic distribution of wind plants in iowa for maximum economic benefit and reliability, *Wind Engineering* 24(4): 271–290.
- Milligan, M. R. & Porter, K. (2008). Determining the capacity value of wind: An updated survey of methods and implementation, *NREL/CP-500-43433*.
- Natarajan, B., Nassar, C. & Chandrasekhar, V. (2000). Generation of correlated rayleigh fading envelopes for spread spectrum applications, *IEEE Communications Letters* 4(1): 9–11.
- Novan, K. M. (2010). Shifting wind: The economics of moving subsidies from power produced to emissions avoided, *Working paper*.
- Segerson, K. (1988). Uncertainty and incentives for nonpoint pollution control, *Journal of Environmental Economics and Management* 15: 87–98.
- Tran, L. C., Wysocki, T. A., Mertins, A. & Seberry, J. (2005). A generalized algorithm for the generation of correlated rayleigh fading envelopes in wireless channels, *EURASIP Journal on Wireless Communications and Networking* 31(1): 801–815.
- Worley, C. M. (2011). *Reaping the whirlwind: Property rights and market failures in wind power*, PhD thesis, Colorado School of Mines.

Geotechnical and Geophysical Studies for Wind Farms in Earthquake Prone Areas

Ferhat Ozcep¹, Mehmet Guzel² and Savas Karabulut¹

¹*Istanbul University*

²*MES Yeraltı Araştırma, Adana
Turkey*

1. Introduction

As Redlinger et al (2002) point out, since antiquity; people have used technology to transform the power of the wind into useful mechanical energy. Wind energy is accepted one of the world's oldest forms of mechanic energy. The re-emergence of the wind as a significant source of the world's energy must rank as one of the significant developments of the late 20th century (Manwell et al, 2009).

Across the Earth's surface, wind is in horizontal motion. Wind power is produced by differences in air pressure between two regions. Wind is a product of solar energy like most other forms of energy in use today. Wind is a clean, abundant, and renewable energy resource that can be tapped to produce electricity. Wind site assessments include: (1) high electricity rates, (2) rebates or tax credits from utilities or governments, (3) a good wind resource, and (4) a long-term perspective (Chiras, 2010).

Procurement costs for critical components and subsystems are given in Table 1. The critical components of *Wind Turbines* include blades, rotor shaft, nacelle, gear box, generator, and pitch control unit. The tower, site foundation, and miscellaneous electrical and mechanical accessories are characterized as subsystem elements. As you can see in Table 1, medium percent cost of site and foundation is 17.3. For this reason, soil investigation should carefully be carried out for the wind energy systems.

2. Soil investigation procedures for wind energy systems

Site investigation is part of the design process (Day, 2006). A foundation is defined as that part of the structure that supports the weight of the structure and transmits the load to underlying soil or rock. The purpose of the site investigation is to obtain the following (Tomlinson, 1995):

- Knowledge of the general topography of the site as it affects foundation design and construction, e.g., surface configuration, adjacent property, the presence of watercourses, ponds, hedges, trees, rock outcrops, etc., and the available access for construction vehicles and materials.
- The location of buried utilities such as electric power and telephone cables, water mains, and sewers.

- The general geology of the area, with particular reference to the main geologic formations underlying the site and the possibility of subsidence from mineral extraction or other causes.
- The previous history and use of the site, including information on any defects or failures of existing or former buildings attributable to foundation conditions.
- Any special features such as the possibility of earthquakes or climate factors such as flooding, seasonal swelling and shrinkage, permafrost, and soil erosion.
- The availability and quality of local construction materials such as concrete aggregates, building and road stone, and water for construction purposes.
- For maritime or river structures, information on tidal ranges and river levels, velocity of tidal and river currents, and other hydrographic and meteorological data.
- A detailed record of the soil and rock strata and groundwater conditions within the zones affected by foundation bearing pressures and construction operations, or of any deeper strata affecting the site conditions in any way.
- Results of laboratory tests on soil and rock samples appropriate to the particular foundation design or construction problems.
- Results of chemical analyses on soil or groundwater to determine possible deleterious effects of foundation structures.

Component	Percent of Total System Cost	Medium Percent Cost
Rotor blades	3 to 11.2	7.1
Gear box and generator	13.4 to 35.4	24.4
Hub, nacelle and shaft	5.3 to 3.5	18.4
Control system elements	4.2 to 10.2	7.2
Tower	5.3 to 31.1	18.2
Site and foundation	8.4 to 26.2	17.3
Miscellaneous engineering	3.2 to 11.4	7.3

Table 1. Estimated Procurement Costs of Critical Components of *Wind Turbines* (Jha, 2010)

An approach for organizing a site investigation assessment is given In Table 2. Geotechnical site characterization requires a full 3-D representation of stratigraphy (including variability), estimates of geotechnical parameters and hydrogeological conditions and properties (Campanella, 2008).

The natural materials that constitute the earth's crust are rather arbitrarily divided by engineers into two categories, soil and rock. Soil is a natural aggregate of mineral grains that can be separated by such gentle mechanical means as agitation in water (Terzaghi and Peck, 1967). in a dynamic sense, seismic waves generated at the source of an earthquake propagate through different soil horizons until they reach the surface at a specific site. The travel paths of these seismic waves in the uppermost soil layers strongly affect their characteristics, producing different effects on earthquake motion at the ground surface. Local amplification caused by surficial soft soils is a significant factor in destructive earthquake motion. Frequently, site conditions determine the types of damage from moderate to large earthquakes (Bard, 1998; Pitikalis, 2004; Safak, 2001).

Site Investigation		Ground Investigation		Records and reports	
Planning	Administration	Preliminary	Feasibility	Priliminary Assesment	Planned Strategy and programme contingency proposals
	Desk Study	Main study	Geotechnical Evaluation		
	Reconnainces		Profiling		
	Constraints		Material and Groundwater characteristics		
Design	Procurement Method	Specialised Studies	Geophysics	Field data Presentation	as per code
	Foundation Design Assesment		Dynamic and static probes		
	Development of Investigation Strategy		Presurmenters		
	Programme of Site Activity		Dilatometers		
			Hydrographic		

Table 2. Planning and Design of Site Investigations (Head, 1986)

The design of a foundation, an earth dam, or a retaining wall cannot be made intelligently unless the designer has at least a reasonably accurate conception of the physical properties of the soils involved. The field and laboratory investigations required to obtain this essential information constitute soil exploration (Ozcep, 2010). There are several soil problems at local and regional scale related to the civil engineering structures (Ozcep, F. and Zarif, H., 2009; Ozcep, et al 2009;2010a, b, c Korkmaz and Ozcep, 2010).

2.1 Subsurface exploration

In order to obtain the detailed record of the soil/rock media and groundwater conditions at the site, subsurface exploration is usually required. Types of subsurface exploration are the borings, test pits, and trenches. Many different types of samplers are used to retrieve soil and rock specimens from the borings. Common examples show three types of samplers, the "California Sampler," Shelby tube sampler, and Standard Penetration Test (SPT) sampler (Day, 2006).

2.2 Field testing

There are many different types of tests that can be performed at the time of drilling and/or project site. The three types of field tests are most commonly used geotechnical practice: *Standard Penetration Test (SPT)*, *Cone Penetration Test (CPT)* and *Geophysical Tests*.

2.2.1 Standard Penetration Test (SPT)

The Standard Penetration Test (SPT) consists of driving a thick-walled sampler into a sand deposit. The measured SPT N value can be influenced by many testing factors and soil conditions. For example, gravel-size particles increase the driving resistance (hence increased N value) by becoming stuck in the SPT sampler tip or barrel. Another factor that could influence the measured SPT N value is groundwater (Day, 2006).

2.2.2 Cone Penetration Test (CPT)

The idea for the Cone Penetration Test (CPT) is similar to that for the Standard Penetration Test, except that instead of a thickwalled sampler being driven into the soil, a steel cone is pushed into the soil. There are many different types of cone penetration devices, such as the mechanical cone, mechanical-friction cone, electric cone, seismic and piezocone (Day, 2006).

2.2.3 Geophysical tests

Broadly speaking, geophysical surveys are used in one of two roles. Firstly, to aid a rapid and economical choice between a number of alternative sites for a proposed project, prior to detailed design investigation and, secondly, as part of the detailed site assessment at the chosen location. Geophysical methods also have a major role to play in resource assessment and the determination of engineering parameters. The recently issued British Code of Practice for Site Investigations (BS 5930:1999) sets out four primary applications for engineering geophysical methods:

1. **Geological investigations:** geophysical methods have a major role to play in mapping stratigraphy, determining the thickness of superficial deposits and the depth to engineering rockhead, establishing weathering profiles, and the study of particular erosional and structural features (e.g. location of buried channels, faults, dykes, etc.).
2. **Resources assessment:** location of aquifers and determination of water quality; exploration of sand and gravel deposits, and rock for aggregate; identification of clay deposits.
3. **Determination of engineering parameters:** such as dynamic elastic moduli needed to solve many soil-structure interaction problems; soil corrosivity for pipeline protection studies; rock rippability and rock quality.
4. **Detection of voids and buried artefacts:** e.g. mineshafts, natural cavities, old foundations, pipelines, wrecks at sea etc.

2.2.3.1 Seismic tests

Seismic tests are conventionally classified into borehole (invasive) and surface (noninvasive) methods. They are based on the propagation of body waves [compressional (P) and/or shear (S)] and surface waves [Rayleigh (R)], which are associated to very small strain levels (i.e. less than 0.001 %) (Woods, 1978). Seismic surveys provide two types of information on the rock or soil mass (McCann et al, 1997):

- Seismic refraction and reflection surveys may be carried out to investigate the continuity of geological strata over the site and the location of major discontinuities, such as fault zones.
- From measurements of the compressional and shear wave velocities it is possible to determine the dynamic elastic moduli of the soil/rock mass and estimate its degree of fracturing

2.2.3.2 Electrical resistivity measurements

Electrical depth soundings are effective in horizontal stratified media, since the spatial distribution of the electrical current in the ground and, hence, the depth of investigation depends on the configuration of the array and the spacing of the electrodes. When using a Standard Wenner or Schlumberger array the depth of investigation increases with the current electrode spacing and this gives rise to an electrical resistivity depth section which can be related to the geological structure beneath the survey line (McCann et al , 1997).

2.3 Laboratory testing

In addition to document review, subsurface exploration and field tests, laboratory testing is an important part of the site investigation. The laboratory testing usually begins once the subsurface exploration and tests is complete. The first step in the laboratory testing is to log in all of the materials (soil, rock, or groundwater) recovered from the subsurface exploration. Then the engineer prepares a laboratory testing program, which basically consists of assigning specific laboratory tests for the soil specimens (Day, 2006).

2.3.1 Index tests

Index tests are the most basic types of laboratory tests performed on soil samples. Index tests include the water content (also known as moisture content), specific gravity tests, unit weight determinations, and particle size distributions and Atterberg limits, which are used to classify the soil (Day, 2006).

2.3.2 Soil classification tests

The purpose of soil classification is to provide the geotechnical engineer with a way to predict the behavior of the soil for engineering projects (Day, 2006).

2.3.3 Shear strength tests

The shear strength of a soil is a basic geotechnical parameter and is required for the analysis of foundations, earthwork, and slope stability problems (Day, 2006).

3. On geophysical and geotechnical parameters based on site-specific soil investigations

A geotechnical study (i.e site-specific soil investigation) must be carried out for all “Wind Farm” projects. All geotechnical designs must be based on a sufficient number of borings, geophysical and geotechnical tests. At each foundation of Wind Energy System (WES), integrated use of one borehole, geophysical and geotechnical tests is strongly recommended. If some sites vary in soil features, different number of suitable boreholes is made on the edges of the proposed foundation, based on discussions and meetings with the

geotechnical/geophysical/geological engineers according to the local soil characteristics. Related to the static and dynamic loads, the parameters and problems such as foundation bearing capacity, settlement, stiffness, possible degradation, soil liquefaction and amplification must be investigated in detail.

There are an interaction between tower stiffness, foundation stiffness and soil stiffness, and these are formed total stiffness of Wind Energy System (WES).

Engineer requires to calculate static and dynamic coefficients of compressibility by using the soil dynamic properties such as:

- G_d [MN/m²] - dynamic shear modulus
- ρ [kg/m³] - soil density [t/m³]; the moist density of natural soil, in case of water saturation including the water filling the pore volume, is introduced as density
- ν - Poisson's ratio.

The dynamic properties of the soil material are obtained by using geophysical testing. These geophysical (spectral analysis of surface waves, seismic CPT, down-hole, seismic cross-hole seismic refraction and reflection, suspension logging, steady-state vibration) tests are based on the low-strain tests. It does not represent the non-linear or non-elastic stress strain behavior of soil materials. These studies must be performed by a qualified geophysical engineer or geophysicists.

The sampling intervals of SPT (standard penetration test) should not be in excess of 1 to 1.5m. CPT (cone penetration testing tests) is recommended, because they continuously give the soil properties with depth. All soil layers that influence foundation of project must be investigated.

3.1 Soil settlement criteria

The settlement analysis is taken in to consideration as immediate elastic settlements (primer) and time-dependent consolidation (secondary) settlements. For the tower, a foundation inclination has 3mm/m permissible value after settlement. In the case of the dynamic analysis of the machine, it should be considered additional rotations of the tower base during power production.

The completely vertical long-term settlement due only to the gravity weights is less than 20mm in any case. This situation should be verified by Geotechnical Engineer.

The safety factor for failure of the soil material (soil shear failure) should be min.3.

3.2 Stiffness requirements

Wind Energy Structures (WES) are subject to strong dynamic stresses. Dynamic system properties, i.e. in particular the natural frequencies of the overall system consisting of the foundation, tower, machine and rotor, are therefore of particular importance for load determination.

The foundation structures in interaction with the foundation soil, is modeled by approximation using equivalent springs (torsion and linear springs). Figure 1 provides a comparison between wind turbine generator system and the simplified analysis model. Each model parameter is dependent on soil properties.

Over its design lifetime, the foundation of wind energy structure must provide the minimum levels of stiffness required in the foundation loads. The rotation of the foundation (and resulting maximum permissible vertical settlement of the foundation soil) under the operational forces is limited to be less than the values of rotational stiffness.

3.3 Ground water and dewatering requirements

The two properties of a rock or soil which are most important in controlling the behaviour of subsurface water are (a) how much water the rock or soil can hold in empty spaces within it, and (b) how easily and rapidly the water can flow through and out of it (McLean and Gribble, 1985).

For all required foundation excavation depths, ground water table level shall be considered. Excavation dewatering due to high ground water levels, presence of water bearing strata or impermeable materials (rock, clays, etc.) must be considered as required by specific site conditions.

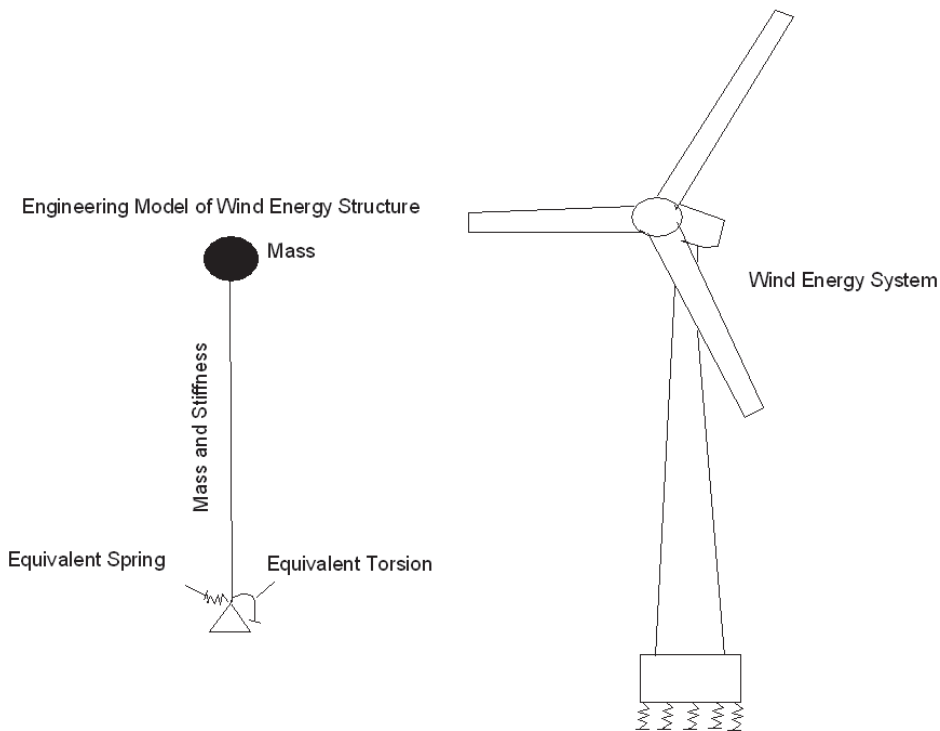

Fig. 1. Wind energy system and the analysis model.

3.4 Design of wind energy systems to withstand earthquakes

Earthquakes impose additional loads on to wind energy systems. The earthquake loading is of **short duration, cyclic** and involves **motion in the horizontal and vertical directions**. Wind energy system (The tower and foundation) need to withstand earthquake forces.

Earthquakes can affect these systems by causing any of the following:

- Soil settlement and cracking
- Liquefaction or loss of shear strength due to increase in pore pressures induced by the earthquake in systems and its foundations;
- Differential movements on faults passing through the foundation

- Soil amplification
- Soil bearing capacity reduction

The potential for such problems depend on:

- The seismicity of the project area
- Soil / rock materials and topographic conditions at the site;
- The type and detailed construction of the wind energy system;
- The groundwater level in the wind energy system at the time of the earthquake.

As shown in Figure 2, the focal distance from an earthquake to a point on the earth's surface is the three dimensional slant distance from the focus to the point, while the epicentral distance is the horizontal distance from the epicentre to the point. Possible earthquake magnitude and these factors (epicentral distance, focal dept and focal distance) are related to the ground motion level at the project site.

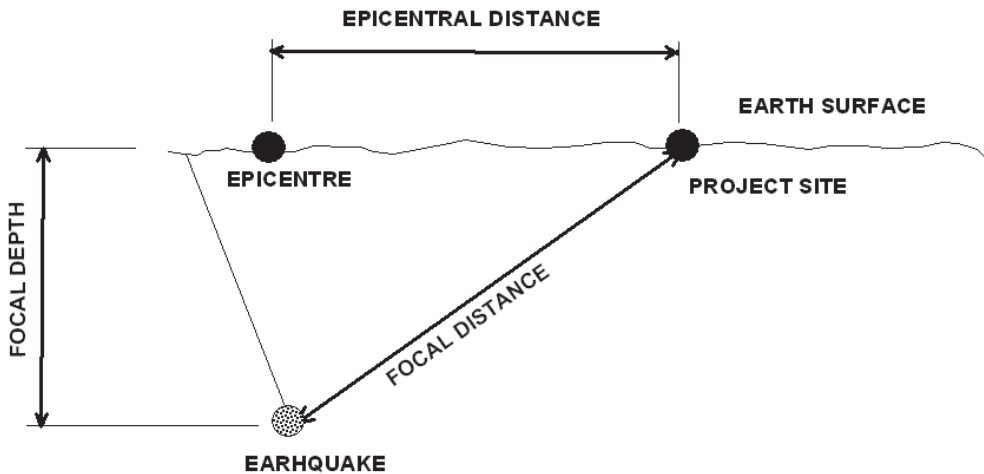

Fig. 2. The focal distance from an earthquake to a point on the earth's surface.

3.4.1 Evaluation of seismic hazard

For a given project site, a seismic hazard evaluation is to identify the seismic sources on which future earthquakes are likely to occur, to estimate the magnitudes and frequency of occurrence of earthquakes on each seismic source, and to identify the distance and orientation of each seismic source in relation to the site. When the deterministic approach is used to characterize the ground motions for project site, then a scenario earthquake is usually used to represent the seismic hazard, and its frequency of occurrence does not directly influence the level of the hazard. In the other hand, when the probabilistic approach is used, then the ground motions from a large number of possible earthquakes are considered and their frequencies of occurrence are key parameters in the analysis (Somerville and Moriwaki, 2003).

3.4.1.1 Probabilistic approach

Given the uncertainty in the timing, location, and magnitude of future earthquakes, and the uncertainty in the level of the ground motion that a specified earthquake will generate at a

particular site, it is often appropriate to use a probabilistic approach to characterizing the ground motion that a given site will experience in the future (Somerville and Moriwaki, 2003).

The probabilistic estimation of ground motion requires the following seismicity information about the surrounding area:

- The rate of occurrence and magnitude of earthquakes;
- The relative proportion of small to large events (b value);
- The maximum earthquake size expected
- The spatial distribution of earthquake epicenters including delineation of faults

3.4.1.2 Seismic hazard from known active faults: deterministic approach

This method is used where faults in the vicinity of the wind farm can be identified. The procedure will usually include:

- Identification of major faults within the vicinity of the wind farm.
- Assessment of whether the faults are active or potentially active, by consideration of whether modern (including small) earthquakes have been recorded along the fault.
- Assessment of the maximum earthquake magnitude on each identified fault. This will usually be determined by considering the length and/or area of the fault and the type of fault. The likely focal depth and, hence, focal distance are also estimated.

3.4.1.3 Selection of design seismic loading

There are two ways of selecting the design seismic loading: *deterministic* and *probabilistic*. Whichever approach is taken, the bedrock ground motions need to be adjusted where appropriate for amplification (or de-amplification) effects. The probabilistic approach to seismic hazard characterization is very compatible with current trends in earthquake engineering and the development of building codes. Examples of conceptual frameworks are given in Figure 3.

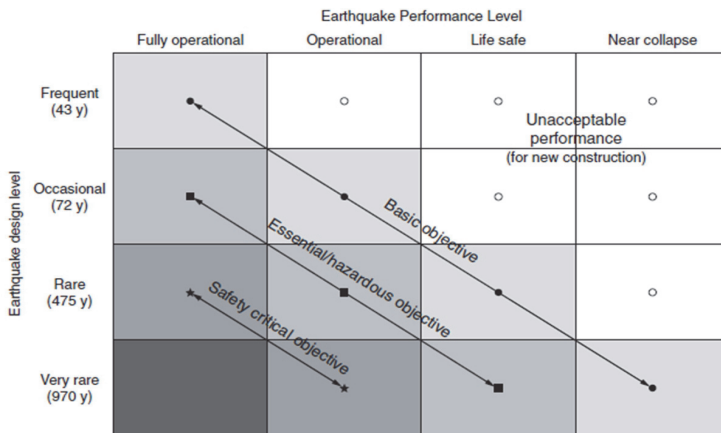

Fig. 3. Seismic performance objectives for buildings (SEAOC, 1996), showing increasingly undesirable performance characteristics from left to right on the horizontal axis and increasing level of ground motion from top to bottom on the vertical axis. Performance objectives for three categories of structures are shown by the diagonal lines (Hall et al, 1995).

4. Bahce (Osmaniye, Turkey) case for wind energy systems (from Ozcep et al, 2010)

4.1 Introduction

Geological observations, geophysical measurements, soil explorations, in-situ tests and laboratory tests have been performed over the study area. This survey has been realized in order to be able to decide basic systems in an element, which is one of the turbine locations of Wind Power Plant (135 MW) that is planned to be constructed in Bahçe county of Osmaniye province and in order to be used as a basis for the superstructure loads to be transferred to the soil in detail. Presentation of the location map of the site with several cities and main seismogenetic fault described in Figure 4.1a.

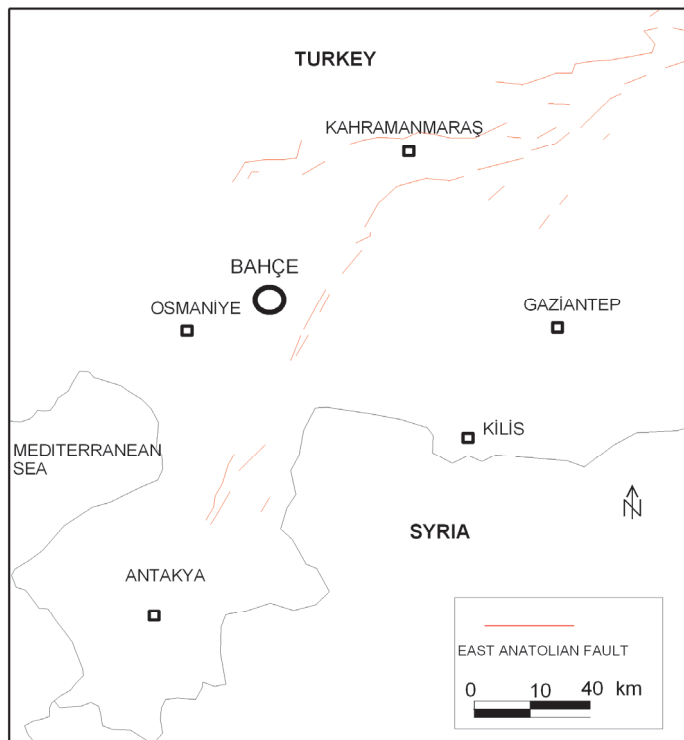

Fig. 4.1a. Presentation of the location map of the site with several cities and main seismogenetic fault

4.1.1 Geological framework

From the structural point of view; Amanos Mountain is located over the intersections of the tectonic zones or within the impact area of these zones which are well known world wide. At Nur Mountain, characteristic folding and faulting properties are being observed. Overturned, overthrust and canted folding in different scales are observed. Spring water

and percolating water are becoming dense in the western part and are being observed over discontinuity zones depending on the structural geology. These springs and percolations have resulted important amount of decomposition over the main rock. The engineering properties of the geological units differ from one region to another depending on the structure and hydro-geology and types of rocks. Study area is near the Eastern Anatolia Fault zone which is strike slip fault zone. Eastern Anatolia Fault has not been formed of only one single fault but has been formed of as a complex fault system or zone.

4.1.2 Seismic hazard analysis of region

Seismic hazard analyses aim at assessing the probability that the ground motion parameter at a site due to the earthquakes from potential seismic sources will exceed a certain value in a given time period (Erdik et al, 1999, Erdik and Durukal, 2004). Deterministic and Probabilistic approaches are used in developing ground motions in professional practice. The deterministic approach is based on selected scenario earthquakes and specified ground motion probability level, which is usually median ground motion or median-plus-one standard deviation. The probabilistic approach encompasses all possible earthquake scenarios, all ground motion probabilities and computes the probability of the ground motion to be experienced at the site exceeding a certain value in a given time period. Empirical attenuation relationships are generally employed in the quantification of seismic hazard in either deterministic or probabilistic approaches (Seismic Microzonation for Municipalities: Manual, 2004).

For deterministic seismic hazard analysis, two fault model are selected namely A (fault rapture is 50 km) and B faults (fault rapture is 245 km) within east Anatolian fault Zone (Table 4.1.1a and 4.1.1b).

Researcher	M (magnitude)	Magnitude Type
Ambraseys and Zatopek (1969)	$M = (0,881 \text{ LOG}(L)) + 5,62$	Ms
Douglas and Ryall (1975)	$M = (\text{LOG}(L) + 4,673) / 0,9$	Ms
Ezen (1981)	$M = (\text{LOG}(L) + 2,19) / 0,577$	Ms
Toksöz et al (1979)	$M = (\text{LOG}(L) + 3,62) / 0,78$	Ms
Wells and Coppersmith (1994)	$M = 5,16 + (1,12 \text{ LOG}(L))$	Mw

Table 4.1.1a. Equations for Rapture Length and Magnitude Estimations

Researchers	M (magnitude) Estimations For A Model	M (magnitude) Estimations For B Model
Ambraseys and Zatopek (1969)	7,1	7,5
Douglas and Ryall (1975)	7,1	7,6
Ezen (1981)	6,7	7,5
Toksöz et al (1978)	6,8	7,4
Wells and Coppersmith (1994)	7,1	7,6

Table 4.1.1b. Selected two fault model (A : fault rupture length is 50 km) and B : fault rupture length is 245 km) within East Anatolian Fault Zone.

Earthquake ranges for analysis were taken from 4.5 to 7.5 about 100 km radius (Table 1c) Gutenberg-Richter recurrence relationships was determined as

$$\text{Log}(N) = a - b M \quad (1)$$

Earthquake occurrence probability were given by using

$$R_m = 1 - e^{-N(M) \cdot D}$$

Where R_m = Risk value (%); D , duration; $N(M)$ for M magnitude (1) equation value.

Magnitude Ranges	$4.5 \leq M < 5.0$	$5.0 \leq M < 5.5$	$5.5 \leq M < 6.0$
Number of Earthquakes	34	9	6

Table 4.1.1c. Earthquake Magnitude ranges in study area about 100 km radius. Data are obtained by BU KOERI, compiled by Kalafat et al, 2007)

Attenuation relationship was defined by several attenuation models (see Table 4.1.2a). From a set of attenuation relationships, the average acceleration values of the cities was calculated with exceeding probability of 10 % in 50 years by using several attenuation models as shown in Table 4.1.2b and c.

<p>a = Acceleration Value (cm/sn²) PHA = Pick Horizontal Acceleration M = Earthquake Magnitude D = Epicentral Distance (km) R = Radial Distance from Focal depth (km)</p>	<p>Researchers</p>
<p>$.a = 1300 e^{0.67M} (R + 25)^{-1.6}$</p>	<p>Donovan (1973)</p>
<p>$.\log a = 3.09 + 0.347 M - 2 \log (R + 25)$</p>	<p>Oliviera (1974)</p>
<p>$\log (a/g) = -1.02 + 0.249 M - \log R - 0.00255 R + 0.26$</p> <p>where; $R = (D^2 + 7.32)^{0.5}$</p>	<p>Joyner and Boore (1981)</p>
<p>$\ln (a_H) = (-3,512 + 0,904M - 1,328 \ln [(R_{seis}^2) + (0,149 e^{0,67M})^2])^{0,5}$ $+ (0,44 - (0,171 \ln(R_{seis})) + (0,405 - (0,222 \ln(R_{seis}))))$</p> <p>where, M is moment magnitude; R_{seis} is shortest distance to seismogenetic fault</p>	<p>Campbel (1997)</p>

Table 4.1.2a. Used Acceleration Attenuation Relationships in this Study

Figure 4.1.1b. shows active fault zones, earthquakes in historical and instrumental periods near study area. Seismic hazard analysis for the region are carried out on the earthquakes bigger than 4.5 for 106 years of period.

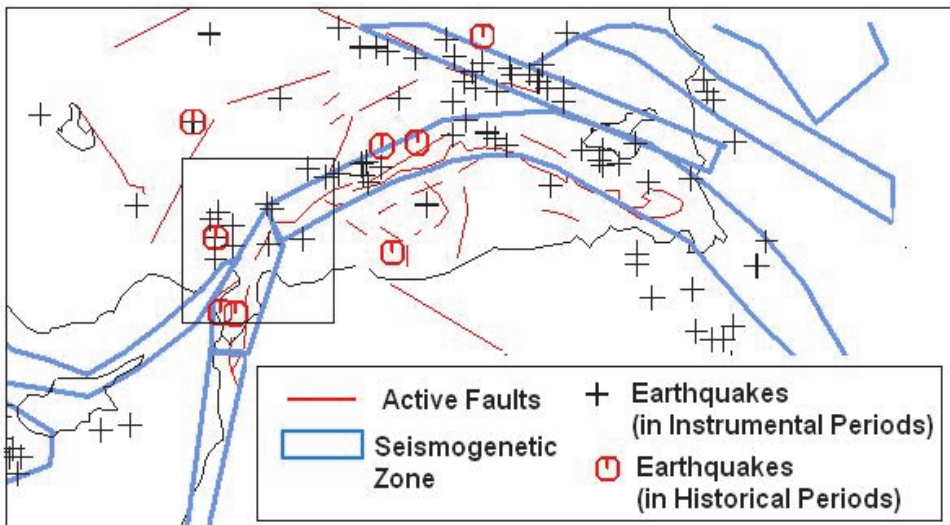

Fig. 4.1.1b. Active fault zones, earthquakes (M larger than 5.5) in Historical and Instrumental time intervals around the Study Area (a quadrangle) (map is redrawn by Erdik et al, 1999)

Poisson probabilistic approach is applied to earthquake data. Table 2b. shows earthquake probability (%) for selected year by Poisson distribution in the study area, and Table 2c shows ground motion level at the site exceeding (%10) in a given time period (50 years).

Magnitude	Probability (%) For D (Year)				Average Return Period (Years)
	10	50	75	100	
5	90,5	100,0	100,0	100,0	4
5,5	56,1	98,4	99,8	100,0	12
6	25,0	76,3	88,5	94,4	34
6,5	9,6	39,6	53,1	63,5	98
7	3,5	16,2	23,3	29,7	281
7,5	1,2	6,0	8,8	11,6	802

Table 4.1.2b. Earthquake Occurrence Probability (%) for D (Year) by Poison distribution in the Study Area

	D (year)	Probability of Exceedence (%)	M (magnitude)	
for	50	10	7,2	
	Δ , Epicentral Distance (km)	H, Focal depth (km)		
for	25	15		
	Donavan (1973)	Oliviera (1974)	Joyner and Boore (1981)	Campbell (1997)
Estimated a (g)	0,26	0,19	0,59	0,45

Table 4.1.2c. Ground motion probabilities show the probability of the ground motion to be experienced at the site exceeding (10%) in a given time period (50 years).

4.3 Site investigations

4.3.1 Test pits

Information has been obtained from observation purpose superficial excavations and in the laboratory evaluations, drilling samples have been used.

4.3.2 Drilling wells

As a result of the observations and analysis performed over the survey area and near environment, it has been planned and realized 2 drilling (SK-1 on the middle of the base, SK-2 at the edge of the base) wells with 30 meter over the area at which the construction base will be settled (Table 4.3a).

Borhole	Depth (m)	LITHOLOGY
SK-1	0,00 - 7,50	gray colored, faulted and fractured, melted cellular from place to place limestone with rarely calcite filled faults, calcite grained, with brown colored decomposition surfaces
	7,50 - 30,00	gray colored, melted cellular limestone with brown colored decomposition surfaces, calcite grained from place to place, fractured, medium sometimes thick layered
SK-2	0,00 - 7,50	gray colored, faulted and fractured, melted cellular from place to place limestone with rarely calcite filled faults, calcite grained, with brown colored decomposition surfaces
	7,50 - 30,00	gray colored, melted cellular limestone with brown colored decomposition surfaces, calcite grained from place to place, fractured, medium sometimes thick layered

Table 4.3a. Lithology according to the drilling results

4.3.3 Surface and ground water

There is no ground or superficial water danger which could affect the basic systems of the turbine planned to be constructed over the survey area. However, the contact and interaction of the superficial water and standing water which can accumulate during and after the construction of the foundations of the turbine as a result of the seasonal precipitations should be prevented.

4.3.4 Field tests

4.3.4.1 SPT tests and core evaluations

Since the survey area is formed by rock units even from the surface (not suitable for SPT experiment), core samples obtained from drillings have been evaluated.

4.3.4.2 Geophysical tests

A. Seismic tests

In the seismic studies which have been performed over the soil of the survey area, mainly seismic refraction method which is used in direct and reverse shooting has been applied. Seismic measurements have been made by measuring both longitudinal (or compressional), V_p and also transversal (or shear), V_s wave velocities. V_p has been measured in order to determine the underground structural locations in horizontal and lateral directions, V_s has been measured in order to know the elastic properties. Geophone intervals in seismic measurements have been selected as 2 m. Table 3b shows geotechnical parameters obtained by seismic tests.

Vp Velocity (m/s)	Vs Velocity (m/s)	Vp/Vs	Density (gr/cm ³)	Poisson Rate	Shear Module (Kgf/cm ²)	Dyn. Ela. Mod. (Young) (Kgf/cm ²)	Soil Amplifications (Borcherdt et al 1991)	Soil Predominant Period To (s)
1811	834	2,17	2,1	0,37	14.922	40.750	0,7	0,16
1835	791	2,32	2,1	0,39	13.419	37.195	0,8	0,17

Table 4.3.b. Average geotechnical parameters obtained by seismic tests

B. Electric resistivity applications

In the resistivity studies which are made in order to clarify the lithological structure of the soil of the survey area, SAS (signal Average System) resistivity measurement system has been used. Soil resistivity is being changed depending on the grain size, water content, porosity and permeability. At the survey area, the variation of the apparent resistivity with the depth has been analyzed by applying Vertical Electric Drilling, in the Schlumberger permutation technique with $2 AB/2 = 40$ m expansion and so the structural disorder, depth, lithology, thickness of layers, underground water capacity, corrosion degree which is especially important in the structuring have been analyzed by using the resistivity differences (Table 4.3c).

Resistivity Value	Corrosion Degree
Resistivity < 10 ohm.m	More Corrosive
10 < Resistivity < 30 ohm.m	Corrosive
30 < Resistivity < 100 ohm.m	Medium Corrosive
100 ohm.m < Resistivity	Not Corrosive

Table 4.3c. Soil Resistivity and Corrosion Level According to Turkish Standards

The results of the measurements obtained in survey area and the soil curves formed by the apparent resistivity values which are varied according to the depth have been evaluated manually and by using computer. The resistivity values of the survey area are as follows (Table 4.3.d).

Resistivity Values of the units in survey area		
Unit	Thickness(m)	Resistivity (Ohm.m)
First Layer	7-8	345-360 Ohm.m
Second Layer	50	1083-1217 Ohm.m

Table 4.3d. Resistivity Values of the units in survey area

4.4 Laboratory tests and analysis

Index / Physical Properties of the Soil / Rock

The tests which are complying with the R.T. Ministry of Public Works norms and TS1900 have been performed over the soil / rock core samples which have been taken from the boreholes that had been drilled during field surveys.

4.5 Engineering analysis and evaluations

4.5.1 Determination of soil -structure relation

a. Foundation System

Required laboratory studies have been made over the observations, soil excavations, geophysical applications about the mentioned foundation soil which has been analyzed regarding geotechnical perspective and the obtained parameters have been specified in the above sections.

The planned structures (wind towers) are high towers having rigid bearing systems. Raft foundation will be a proper foundation solution for this project since this kind of a foundation will provide safety against differential settlements, will protect the integrity of the bearing system under the earthquake loads and dynamic wind load, as well as static loads.

b. Bearing Capacity

Allowable bearing capacity calculations regarding the related parameters about either soil / rock or structure have been made separately in different approaches by taking into account land data, laboratory experiment results and drilling core observations and Rock Quality *Designation* (RQD) values. The rock and soil formations of the environment have been taken into account in the selection of the calculation methods. At the soil / rock locations which are not convenient to provide samples proper for the experiments required for the method (especially in rock tri-axial experiment required for the Bell method), values which have been obtained from the other locations of the same unit or the known technical literature values have been taken into account.

c. Settlements

Even it is not expected to occur the Settlements which exceeds the acceptable limits under the load to the soil as a result of the structuring over this soil of which most parts that the structure foundation will be based are clay, silt the Settlements value of the medium which has been calculated according to the elasticity module (dynamic) and Poisson ratio values.

Special attention should be given not to place the foundation over the excessive splitted, weak durable or decomposed units except the survey points during the foundation excavation and not to place the foundation over differentiated units. Before the construction

and after the excavation, and during and after the construction, it is required to protect the foundation area from the superficial waters and rains and adequate discharging system should be designed.

d. Liquefaction

There is no ground water danger in a depth up to 20 meters which can negatively affect the foundation structure over the survey area.

e. Soil Class and Other Parameters

The soil of the survey area is rock formed of faulted, fractured, layered limestone units, V_s shear wave velocity (if the thin layer in the surface is ignored) which has been obtained from the Geophysical – Seismic studies has been measured in between 791-834 m/s. According to the Turkish Earthquake Code, these velocities correspond to Soil Group (A), Local Soil Class (Z1) but since these units are fractured and have frequent discontinuity intervals, it is better to classify them as B group Z2 soil class. A little bit more clarification explaining the difference between both classes is given Table 4.5.1 and 4.5.2. Spectrum characteristic periods which are regarded according to the selected foundation type **TA and TB** are respectively **0,10-0,40 (s)**. Soil dominant vibration period has been calculated as **0,16 sec**.

<i>Soil Group</i>	<i>Shear Wave Velocity (m/s)</i>
(A)	> 700
(B)	400–700

Table 4.5.2. Soil Groups according to Turkish Earthquake Design Code

Local Site Class	Soil Group according to Table 6 and Topmost Layer Thickness (h_1)	Spectrum Characteristic Periods (T_A , T_B)
Z1	Group (A) soils Group (B) soils with $h_1 \leq 15$ m	Between 0.10 and 0.30 s
Z2	Group (B) soils with $h_1 > 15$ m Group (C) soils with $h_1 \leq 15$ m	Between 0.15 and 0.40 s

Table 4.5.3. Local Site Class and Spectrum Characteristic Periods (T_A , T_B) According To Turkish Earthquake Design Code

5. Conclusions and suggestions

The following results have been obtained after the geological, geophysical, geotechnical studies performed over the area at which the Wind Power Plant turbine (Osmaniye Bahçe) will be constructed;

- a. In the performed observational geological surveys; as a result of the laboratory experiments performed over the core drilling applications of which the survey depth is 30 meter, geophysical seismic velocity measurements and electric sounding (resistivity) applications, samples / drilling cores obtained from the soil.
- b. It has been found out that there are limestone units which are gray colored, cracked and fractured, melted cellular from place to place, with rarely calcite filled cracks,
- c. calcite grained, with brown colored decomposition surfaces up to 7,5 meter and from this depth until 30 meters,
- d. it has been found out that there are limestone units which are gray colored, melted cellular, with brown colored decomposition surfaces, calcite grained from place to place, fractured, medium sometimes thick layered.
- e. The point load bearing of the ponderous samples of the units are in between 19,83-58,78 kg/cm² values and the uniaxial pressure bearing are in between 125,44-358,64 kg/cm² values. Cohesion value against the main rock is (Si)=6,72 Mpa and internal friction angle is (ϕ)=34,80. These data are obtained by laboratory measurements.
- f. Over the survey area, there is no natural disaster risk such as floods, landslides, flows, avalanches, rock fallings are not observed.
- g. Over the survey area, there is no underground water which could negatively affect the foundations of the turbine. There is no liquefaction hazard.
- h. Even it is not expected to occur the settlements which exceed the acceptable limits under the load to the soil as a result of the structuring over this soil of which most parts that the structure foundation will be based are limestone. The cracked, fractured, decomposed units at the upper parts should be removed gradually and in a controlled manner during the foundation excavation. Special attention should be given not to place the foundation over the excessive splitted, weak durable or decomposed units except the survey points.

It is required to inform the designing company whenever a situation such as undesirable due to the foundation structuring or poor durability, micro faults, etc., is met different than the soil profile described in logs, in order company to get necessary precautions on time and in required locations.

e) **Raft (spread) foundation** will be a proper foundation solution in order to be on the safe side against cracks and discontinuities, since this kind of a foundation will provide safety against differential settlements, will protect the integrity of the bearing system under the earthquake loads and dynamic wind load, as well as static loads. After the foundation excavations are completed, the upper surface of the foundation soil should be smoothly leveled and the foundation construction (in order to increase the friction) should be started by concreting over the natural soil surface.

6. References

- Ambraseys, N.N. & Zapotek, A. (1969). The Mudurnu valley (West Anatolia, Turkey) earthquake of 22 July 1967, *Bull. of the Seis. Soc. of Am.*, 59,2,521-589 p.

- Bard, P.Y. (1998). Microtremor measurements: a tool for site effect estimation ? *Proceedings Second International Symposium on the Effects of Surface Geology on Seismic Motion – ESG98*, Yokohama, Japan, pp. 1251-1279.
- Borcherdt, R.D.; Wentworth, C.M.; Janssen, A.; Fumal, T. & Gibbs, J. (1991). Methodology for Predictive GIS Mapping of Special Study Zones for Strong Ground Shaking in the San Francisco Bay Region, *Proc. Fourth Intern'l. Conf. on Seismic Zonation*, Vol.3, pp. 545-552.
- BS 5930, (1999). The Code of Practice for Site Investigations, *The British Standards Institution*.
- Campbell, K.W. (1997). Empirical Near-Source Attenuation Relationships for Horizontal and Vertical Components of Peak Ground Acceleration, Peak Ground Velocity, and Pseudo-Absolute Acceleration Response Spectra, *Seismological Research Letters*, Vol. 68, No. 1, pp. 154-179.
- Campanella, R.G. (2008). Geo-environmental site characterization, *Geotechnical and Geophysical Site Characterization – Huang & Mayne (eds)*, Taylor & Francis Group, London, ISBN 978-0-415-46936-4
- Chiras, D. (2010). *Wind Power Basics*, New Society Publishers, P.O. Box 189, Gabriola Island, BC v0r 1x0, Canada
- Day, R., 2006, *Foundation Engineering Handbook*, The McGraw-Hill.
- Douglas, M.B., Ryall, A. (1975). Return periods for rock acceleration in western Nevada , *Bull. of the Seis. Soc. of Am.*, 65: 1599-1611
- Donovan, N.C. (1973). A Statistical Evaluation of Strong Motion Data Including the February 9, 1971 San Fernando Earthquake, *World Conference on Earthquake Engineering, V, Rome, Proceedings*, v. 2, paper 155., Milano, Italia.
- Erdik, M. & Durukal, E. (2004) Strong Ground Motion in Recent Advances, In: *Earthquake Geotechnical Engineering and Microzonation*, A. Ansal (ed.) , Kluwer Academic Publishers, Netherlands.
- Erdik, M.; Alpay, T.; Biro, Y.; Onur, T.; Sesetyan, K. & Birgoren, G. (1999). Assessment of earthquake hazard in Turkey and neighboring regions, *Annali di Geofisica*, Vol. 42, pp. 1125-1138.
- Ezen, Ü. (1981). Kuzey Anadolu fay zonunda deprem kaynak parametrelerinin magnitüde ilişkisi, *Deprem Araştırma Enstitüsü Dergisi*, No: 31, p. 32, Ankara.
- Hall, J.H.; Heaton, T.H.; Halling, M.W. & Wald, D.J., (1995). Near-Source Ground Motion and its Effects on Flexible Buildings, *Earthquake Spectra*, Vol. 11.
- Head, J.M. (1986). Planning and Design of Site Investigations, In: *Site Investigation Practice: Assessing BS 5930*, edited by A. B. Hawkins *Geological Society, Engineering Geology Special Publication No. 2*.
- Jha, A.R. (2010). *Wind Turbine Technology*, CRC Pres.
- Joyner, W.B. & Boore, D.M. (1981). Peak Horizontal Acceleration and Velocity from Strong Motion Records, Including Records from the 1979 Imperial Valley, California, Earthquake, *Bull. Seis. Soc. Am.*, Vol:71, No:6, pp. 2011-2038.
- Kalafat, D.; Gunes, Y.; Kara, M.; Deniz, P.; Kekovali, K.; Kuleli, S.; Gulen, L.; Yilmazer, M. & Ozel, N.M. (2007). *A revised and extended earthquake catalog for Turkey since 1900 (M > 4.0)*, Bogazici University Kandilli Observatory and Earthquake Research Institute, İstanbul.
- Oliviera, C.S. (1974). *Seismic Risk Analysis*, Univ. of California, Berkeley, Report no: EERC 74-1

- Manwell, J.; McGowan, J. & Rogers, A. (2009). *Wind Energy Explained: Theory, Design, And Application*, John Wiley & Sons Ltd.
- McLean, A.C., Gribble, C.D. (1985). *Geology For Civil Engineers*, Taylor & Francis.
- McCann, D. M., Eddleston, M., Fenning, P. J. & Reeves, G. M. (eds), 1997, *Modern Geophysics in Engineering Geology*. Geological Society Engineering Geology Special Publication No. 12, pp. 3-34.
- Ozcep, F., Guzel, M., Kepekci, D., Laman, M., Bozdog, S., Cetin, H. & Akat, A. (2009). Geotechnical and Geophysical Studies for Wind Energy Systems İn Earthquake-Prone Areas: Bahce (Osmaniye, Turkey) Case, *International Journal of Physical Sciences* Vol. 4 (10), pp. 555-561.
- Ozcep, F. (2010). SoilEngineering: a Microsofts Excel® Spreadsheet© Program for Geotechnical and Geophysical Analysis of Soils, *Computers & Geosciences, Volume 36, Issue 10, October 2010, Pages 1355-1361*
- Ozcep, F. & Zarif, H. (2009). Variations Of Soil Liquefaction Safety Factors Depending On Several Design Earthquakes in The City Of Yalova (Turkey), *Scientific Research and Essay* Vol. 4 (6) pp. 594-604.
- Ozcep, F.; Tezel, O. & Asci, M. (2009). Correlation between Electrical Resistivity and Soil-Water Content: Istanbul and Golcuk, *International Journal of Physical Sciences*, Vol. 4 (6), pp. 362-365.
- Ozcep, F.; Yildırım, E.; Tezel, O.; Asci, M. & Karabulut, S. (2010a). Correlation between Electrical Resistivity and Soil-Water Content based Artificial Intelligent techniques, *International Journal of Physical Sciences*, Vol. 5 (1), pp. 047 – 056.
- Korkmaz, B. & Ozcep, F., (2010). Fast and Efficient Use of Geophysical and Geotechnical Data in Urban Microzonation Studies At Small Scales : Using Sisli (Istanbul) As Example, *International Journal of Physical Sciences*, Vol. 5 (2), pp. 158 – 169.
- Ozcep, F.; Karabulut, S.; Korkmaz, B. & Zarif , H. (2010b). Seismic Microzonation Studies in Sisli / Istanbul (Turkey), *Scientific Research and Essay*, 4 July 2010; 5(13), pp. 1595 – 1614.
- Ozcep, F.; Erol, E.; Saraçoğlu, F. & Haliloğlu, M. (2010c). Seismic slope stability analysis: Gurpinar (istanbul) as a case history, *Scientific Research and Essay*, 4 July 2010; 5(13), pp. 1615 - 1631.
- Pitikalis, G. (2004). Site effects, In: *Recent Advances in Earthquake Geotechnical Engineering and Microzonation*, A. Ansal (Ed.) Kluwer Academic Publishers, Netherlands, p. 139-197.
- Redlinger, R.Y.; Andersen, P.D. & Morthorst, P.E. (2002). *Wind Energy in the 21st Century: Economics, Policy, Technology and the Changing Electricity Industry*, PALGRAVE Pub.
- Safak, E. (2001). Local site effects and dynamic soil behavior, *Soil Dynamics and Earthquake Engineering* 21(5), 453-458.
- Somerville, P. & Moriwaki, Y. (2003). Seismic Hazards and Risk Assessment in Engineering Practice, In: *International Handbook Of Earthquake And Engineering Seismology, Vol. 81B*, Edited by William H. K. Lee, Hiroo Kanamori, Paul C. Jennings, and Carl Kisslinger.
- Terzaghi, K. & Peck, R.B. (1967). *Soil Mechanics in Engineering Practice*, Second Edition, A Wiley International Edition, New York. 321pp.
- Toksöz, N.; Nabalek, J. & Arpat, E. (1978). Source Properties Of The 1976 Earthquake İn East Turkey, *Tectonophysics*, 49, 3-4, 199-205.

- Tomlinson, M.J., 1995, *Foundation Design and Construction*, 5th ed., John Wiley & Sons, Inc., New York.
- Wells, D.L. & Coppersmith, K.J. (1994). New Empirical Relationships among magnitude, rupture length, rupture width, rupture area, and surface displacement, *Bull. of the Seis. Soc. of Am.*, 84, N0: 4, 974-1002.
- Woods, R. D. (1978) Measurement of dynamic soil properties, *Earthquake Engineering and Soil Dynamics*, Pasadena, CA, 1: 91-179

A Holistic Approach for Wind Farm Site Selection by FAHP

Ilhan Talinli¹, Emel Topuz¹, Egemen Aydin¹ and Sibel B. Kabakcı²

¹*Istanbul Technical University, Environmental Engineering Department*

²*Yalova University, Energy Systems Engineering Department*

Turkey

1. Introduction

In recent years an increasing number of countries have implemented policy measures to promote renewable energy. However, the most important problem that the policy makers face with is the conflicting linguistic terms and subjective opinions on energy and environment policy. As the environmental policy and energy policy always go hand in hand, it is quite clear that wind as a renewable resource should be competitive with conventional power generation sources. From technical, environmental, socio-economical and socio-political standpoint, wind power is the most deserving of all of the cleaner energy production options (geothermal, solar, tidal, biomass, hydro) for more widespread deployment. Although wind power is a never ending green resource, assessment of environmental risks and impacts- which comprise the backbone of environmental policy- in the context of specific projects or sites often are necessary to explicate and weigh the environmental trade-offs that are involved. In the case of wind farms, a number of turbines (ranging from about 250 kW to 750 kW) are connected together to generate large amounts of power. Apart from the constraints resulting from the number of turbines, any site selection should think over the technical, economic, social, environmental and political aspects. Each aspect uses criteria for its own evaluation. Decision making by using multi criteria decision analysis is an attractive solution for obtaining an integrated decision making result. Although Lee et al. (2009), Kaya and Kahraman (2010) and Tegou et al. (2010) has studied wind farm site selection by using different kinds of Analytic Hierarchy Process (AHP), Cheng's extent analysis of Fuzzy AHP (FAHP) is used in this study and a holistic hierarchy were developed.

The analytic hierarchy process (AHP) is a multi-criteria decision making tool to deal with complex, unstructured and multi-attribute problems. This method is distinguished from other multi-criteria methods in three ways: I. Construction of the hierarchy structure II. Pair-wise comparisons of different criteria III. Weighing with respective to the overall objective. In AHP, decision makers quantify the importance of criteria by using Cheng's 1-9 scale. To overcome the disadvantage of reluctant and inconsistent comparison judgments, fuzzy analytic hierarchy process (FAHP) might be used on each factor to determine the weight of fuzziness of its attributes. Hierarchy structure diagram of wind farm site selection is given in Figure 1. This study aims to apply the FAHP to find priority sequence of alternatives and obtain the key success factors for the selection of appropriate sites of wind farms.

Technical factors are related with the suitability of site for wind energy production. An average wind speed must be sustained in the area in order to produce wind energy. Land topography and geology must ensure some specifications for turbine construction. Turbine size is also a distinguishing factor, because it changes region to region due to some regional differences. Additionally, wind farm siting depends on existing grid structure and connection conditions for transmission process. Capital costs such as construction, equipment e.g., land and operational & management costs change from site to site based on site specifications. Electricity market in the region will affect the capacity of the farm directly. Incentives provided by some regional governance can determine the attractiveness of the site for wind farm due to economic reasons. When the wind energy production process is evaluated in a systematic manner, it is seen that possible environmental impacts are related with noise, aesthetic, wild life and endangered species near wind farm site and electromagnetic interference. Socio-political aspects consist of regulating barriers, public acceptance, land use in the area and distance from residential area. Regulatory actions differ for regions and set some restrictions or incentives related with the siting of wind farms such as limitations for distance from grid or land use in the area. As a part of wind farm projects, public may oppose wind farm siting due to some regional specifications such as environmental aspects. Alternative and especially existing land use options in the region might reduce or increase the suitability of wind farm siting such as being a touristic or strategic region. More factors could be added to or some factors could be eliminated from hierarchy based on the need of analysis or characteristics of the sites that are being evaluated.

In conclusion, although wind is one of the renewable energy sources and has begun to be preferred commonly; wind farm siting must be evaluated with a holistic approach by considering all of the aspects such as technical, economic, environmental and socio-political in order to integrate energy policy with environmental policy for a sustainable environment.

2. Wind farm

In recent years, many people have recognized the value of wind power as a major renewable energy source of long term; because wind is free, clean and renewable. Thus, using wind power helps to reduce the dependence on traditional fossil fuel based power generation. This in turn ensures the environmental sustainability and security of supply. Furthermore, wind energy is reported to be close to becoming financially self-sustaining without the extensive governmental support (Welch and Venkateswaran, 2009).

Wind energy can be harnessed by a single wind turbine or several power generating units which are commonly called as wind farm. A wind farm has the following components:

- wind turbines
- towers
- transformers
- internal access roads
- transformer station
- transmission system connecting the facility to the national grid (UNDP, 2010).

The blades of the turbine collect the kinetic energy of the wind. Flow of the wind over the blade causes lift which results in a rotation. The blades are connected to a drive shaft that turns an electric generator through a gear box. The profitability of generating wind energy mainly depends on the site of the wind farm. An inadequate site selection would lead to lower than

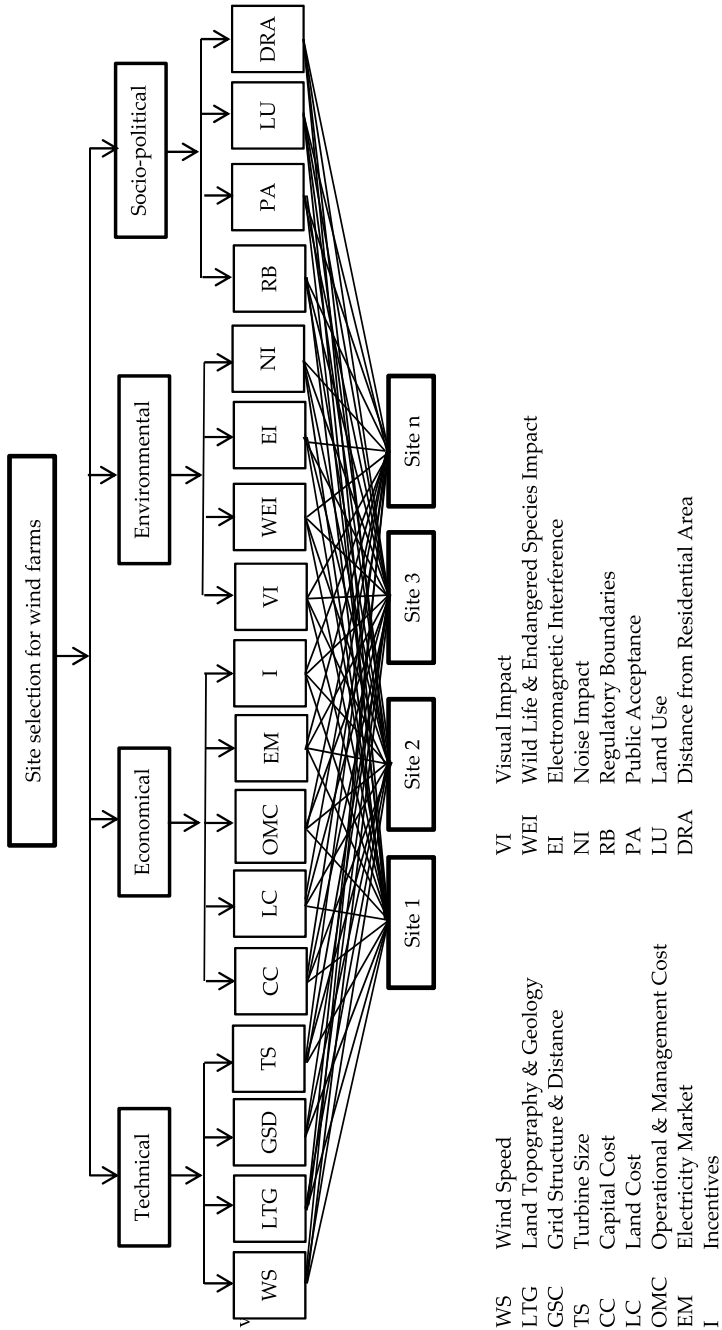

* Priority Number

Fig. 1. Hierarchy structure diagram for wind farm site selection

expected wind power capture, increased maintenance costs, and so on (Kusiak and Song, 2010). Finding a wind farm site is so critical that the site is required to maximize the energy production and minimize the capital cost (EWEA, 2009). The decision of which areas to consider for siting wind farms and where to place wind turbines is a complex study involving not only technical considerations, but also economic, social and environmental requirements (Tegou et al., 2010). This complexity is resulting because of the combination of obstacles in siting process including environmental, topographic and geographic constraints, public opposition, regulatory barriers etc.

2.1 Technical considerations

Many technical factors affect the decision making on site selection including wind speed, land topography and geology, grid structure and distance and turbine size. These technical factors must be understood in order to give pair-wise scores to sub-factors.

2.1.1 Wind speed

The viability of wind power in a given site depends on having sufficient wind speed available at the height at which the turbine is to be installed (Vanek and Albright, 2008). Any choice of wind turbine design must be based on the average wind velocity at the selected wind turbine construction site (Ucar and Balo, 2009). In most of the countries, meteorological stations may provide average wind velocity data and wind maps for the regions. Cubic wind speed directly related with the energy generation potential of wind. Site's wind energy potential can be formulated with the wind power density which represents the effect of wind speed distribution and wind speed. Wind speed data must be recorded for at least 1 year in order to have mapping for potential energy yield over site. WindPro, WAsP, MesoMap are most widely used wind source mesoscale mapping software that use a variety of parameters in order to combine weather and wind flow models (Ozerdem et al., 2006).

2.1.2 Land topography and geology

The speed and the direction of wind can be various depending on the characteristics of topography (Brower, 1992). Wind farms typically need large lands. Topography and prevailing wind conditions determine turbine placement and spacing within a wind farm. In flat areas where there is nothing to interfere with wind flow, at least 2600-6000 m²/MW may be required (Kikuchi, 2008). More land may be needed in areas with more rugged or complex topography and/or wind flow interference. Wind turbines are usually sited on farms that have slope smaller than 10-20% (Baban and Parry, 2001). Garrique or maquis are more advantageous than forests as land cover for wind farm sitting (Tegou et al., 2010). It would be needed to clear and grade land in order to provide roads for trucks, constructions trailer or equipment storage area, access to construction site. Soil stability, foundation requirements, drainage and erosion problems must be assess by conducting geotechnical study (Ozerdem et al., 2006).

2.1.3 Grid structure and distance

The connection of wind turbines to an electricity grid can potentially affect reliability of supply and power quality, due to the unpredictable fluctuations in wind power output (Weisser and Garcia, 2005). Feeding intermittent power into electricity grids can affect

power quality. The impact depends primarily on the degree to which the intermittent source contributes to instantaneous load (i.e. on power penetration). At low penetrations, wind farms can be connected to the grid as active power generators, with control tasks concentrated at conventional plants. Many studies agree that penetrations of up to 10–20% can be absorbed in electricity networks without adversely affecting power quality and needing extra reserve capacity (Weisser and Garcia, 2005). Grid distance is one of the 10 most important steps that were determined by American Wind Energy Association (AWEA) for wind farm building (AWEA, 2007).

2.1.4 Turbine size

Required height for the installation of turbine above ground is one of the important factors that affect the annual energy generation (Herbert et al., 2007). Turbine size is related with the energy output, because the bigger the turbine size is, the more wind it is exposed to. However, bigger turbines need bigger turbine towers which can be limited with construction and maintenance related with site dependent specifications (Munday et al., 2011).

2.2 Economic considerations

The economic sub factors that affect the site selection include capital cost, land cost and operational and management costs. One of the biggest advantages of renewable energy sources is that there is no fuel cost during operation of the plant, therefore contribution of capital cost to the overall wind farm economy is very high. It is important to make economical evaluations by considering time value of money due to long periods of service life of wind farm projects (Ozerdem et al., 2006).

2.2.1 Capital cost

Construction, electrical connection, grid connection, planning, wind turbines, approvals, utilities and management are the main components of capital cost for wind farm projects (Lee et al., 2009). There will be meteorological towers which will include anemometers to measure wind speed and direction, a data logger and meteorological mast. Steel tube or lattice could be used to construct these towers and would be free standing or guyed. It is required to take a special permit in order to build such a meteorological tower (AWEA, 2007). Capital cost related with these components will change due to region that wind farm is located. It would be needed to clear about 150-250 feet around a wind turbine site to prepare wind turbine construction. Electrical collection lines are constructed in order to connect wind turbines and collection substation. Based on the land geometry, costs of these lines vary. Even, O&M building would need new roadways, sewage collection system to main collector or installation of municipal water connection. In addition, construction debris is also one of the expenses that must be considered.

Capital cost of a typical wind farm project change between £600,000 and £1,000,000 per MW per annum. Turbine costs (64%), construction (13%) and electrical infrastructure (8%) costs constitute the major items of capital expenditures (Munday et al., 2011). The amount of transmission infrastructure that has to be installed directly increases the cost of building a wind farm. Therefore, availability of existing transmission lines should be considered in selecting a site.

2.2.2 Land cost

Generally, wind power production cost is currently higher than that of the conventional fuels. Technology of the production is the main effect of cost in the case of production cost. But for the site selection, main economic factor is the cost of the land where the wind farm is constructed; because, the cost of land primarily depends on the region, soil condition and the distance from the residential area. Since large areas are needed for wind farms, the rent or cost of the land becomes the major factor of site selection. For a commercially viable project, the size of the site is a crucial parameter. As the size of the site gets bigger, the possibility of facing with more than one landowner increases. The ideal situation is to communicate with few landowners who can give exclusive rights to the wind power project owner.

2.2.3 Operational and management cost

There will be control functions such as supervisory control and data acquisition (SCADA) which will provide control of each wind turbine in O&M facilities. It is estimated that O&M cost of wind farms require about £8000-£10,000 per MW per annum. Business rates, maintenance expenses, rents, staff payments are main components of O&M costs. O&M cost are usually very small percentage of total investment costs of wind farm projects (Munday et al., 2011).

2.2.4 Electricity market

Existing of an electricity market for the energy generated is an important factor affecting the economic benefits of the project. There should be energy demand in regions close to wind farms. When the intermittency of the wind energy taken into consideration, a continuous electricity market gains an extra importance for the region wind farm sited.

2.2.5 Incentives

Incentives are economic tools applied in order to encourage investors to support socially beneficial projects such as renewable energy projects that reduce the number of thermal power plants and so the carbon emissions. Regions, where advantageous incentives applied for wind energy generators, are very fascinating for the economic considerations.

Applications of incentives such as specific levy exemptions and renewables obligations certificates vary from region to region (Munday et al., 2011). For example, China has been applying some concession programs for wind power generation since 2005 (Zhang, 2007). In Turkey, in the Law on The Utilization of Renewable Energy Resources For The Purpose of Generating Electrical Energy, there is a special case for the investors in the cost of land. In the case of utilization of property which is under the possession of Forestry or Treasury or under the sovereignty of the State for the purpose of generating electricity from the renewable energy resources included in the law, these territories are permitted on the basis of its sale price, rented, given right of access, or usage permission by the Ministry of Environment and Forestry or the Ministry of Finance (Erdoğan, 2009). A 50% deduction shall be implemented for permission, rent, right of access, and usage permission in the investment period.

2.3 Environmental considerations

The environmental sub factors that affect the site selection of a wind farm include visual impact, electromagnetic interference, wild life and endangered species and noise impact. As

a renewable energy source, wind farm do not cause reduction in natural resources. As a result of having no input other than wind, there is no formation of emission during the energy generation process. Wind turbines can generate noise while they are working and their image can be incompatible with the general view of the region. Wild life and endangered species could be disturbed during the construction of wind farm.

2.3.1 Visual impact

Wind turbines are located in windy places, and most of the time, those places are highly visible. To many people, those big towers with 2 or 3 blades create visual pollution. To minimize the impacts of visual pollution, many investors implement the actions listed below:

- The wind turbine tower, nacelle and blades as well as the transformer box, is painted a neutral color to blend in with the surroundings.
- The turbine is sited to reduce the possibility of shadow flicker falling on surrounding inhabited structures.

2.3.2 Wild life & endangered species

Wind farms affect birds mainly through the actions listed below:

- collision with turbines and associated power lines,
- disturbance leading to displacement including barriers to movement,
- loss of habitat resulting from wind turbines (Bright et al., 2008; Kikuchi, 2008).

To minimise the risk of bird collision, site selection should be done precisely. But decision making in site selection is problematic due to the reason that migration roads of birds may vary from one year to another. Long term monitoring before giving the decision is necessary. Also, soil and water habitat must be protected from possible effects of wind farm projects (AWEA, 2007).

2.3.3 Electromagnetic interference

Electromagnetic interference is an electromagnetic disturbance that interrupts, obstructs, or degrades the effective performance of electronics or electrical equipment (Manwell et al., 2002). Wind turbines may reflect, scatter or diffract the electromagnetic waves which in turn interfere with the original signal arriving at the receiver. Although several parameters that influence the extent of electromagnetic interference are listed in the study of Manwell et al. (2002) the blade construction material and rotational speed are key parameters (AWEA, 2007).

2.3.4 Noise impact

Noise can generally be classified according to its two main sources: aerodynamic and mechanical. Aerodynamic noise is produced when the turbine blades interact with eddies caused by atmospheric turbulence. Mechanical noise is generated by the rotor machinery such as the gearbox and generator. Noise could be reduced by better designed turbine blade geometry and by selection of proper operating conditions (Cavallaro and Ciraolo, 2005).

2.4 Social considerations

Social factors that affect the selection of a site include public acceptance, distance from residential area and alternative land use options of candidate wind farm site. Some

regulatory procedures may set restrictions or incentives to apply wind farm projects. Public acceptance is vital for the application of that kind of projects. Public may oppose projects because of possible environmental or social effects. Distance from residential area gain importance not to interfere with social life during wind farm construction or operation.

2.4.1 Regulatory boundaries

There may be some national or international level regulation related with the construction and operation of wind farms. These regulations must be explored before evaluating the socio-political position of a wind farm project. Most of them probably change from region to region. For example this distance is given as 300 m in the study of Clarke (1991), and 500m in the study of Yue and Wang (2006). Some nations encourage use of renewable energy resource and develop special regulations for the renewable energy generation plants. On the other hand, there could be some restrictions related with the construction and operation of energy generating plant. For example, in many of the national legislations, there is a distance where wind turbines are located from bird flyways.

2.4.2 Public acceptance

Public is the most vital component of a region and their opposition to issues can lead to abolish proposed projects. Support of public for wind energy generation is expected to be high in general but proposed wind farms have often been met with strong local opposition. In the study of D.van der Horst and Toke (2010), it is stated that nearby residents are more likely to become involved in decision making. It is recommended to inform public before deciding to construct a wind farm in a region especially where alternative land use is more beneficial to public than wind farm sitting (AEWA, 2007).

2.4.3 Land use

Land use affects the decision of wind farm siting from two points of view. Firstly, there are some cases where no wind farms can be built although sufficient wind speed was detected. These cases are mainly related with land use or condition. Land related constraints are:

- forest area
- wetlands
- land of high productivity
- archaeological sites
- aviation zones
- military zones

Alternative land uses of site where wind farm to be constructed affect the decision of wind farm site. More beneficial land uses for public especially such as agriculture, potential of being residential or industrial area, tourism cause oppositions and more detailed analysis of decision.

2.4.4 Distance from the residential area

Wind turbines are giant machines that can be over 120m tall and have blades that sweep up to 6000m² in area. Because of their big size, these machines have the potential to disturb visual scene. Besides, noise and vibration stemming from the wind turbines may cause residents to suffer from sleep disturbance, headaches, visual blurring. Those types of complaints can be avoided if the wind turbines are sited a considerable distance from the

residential area. In addition, construction of wind farm can disturb social life in the region for a long time due to large trucks carrying blades and debris from site excavation and construction machines.

3. FAHP Chang’s model

AHP is a multi-criteria decision making tool which provides to structure complex problems in a hierarchic manner, as a result it simplifies evaluating all of the criteria which are relevant with the decision that must be given (Saaty, 1980). All of the alternatives are compared pairwise based on each criterion by using a preference scale and a priority list of alternatives is achieved for each criterion (Taha, 2003). Most widely used preference scale is 1-9 scale which lies between “equal importance” to “extreme importance”. Fuzzy AHP enables the decision analyst to give more realistic scores for alternatives for the cases in which there are lots of uncertainties. For different perspectives, a variety of modified versions of fuzzy AHP can be used. Chang’s model of extent analysis (1992) is one of them which depends on degree of possibility of the each criterion. Triangular fuzzy numbers (l, m, u) are used in order to develop pair wise comparison scale and a pair wise comparison matrix is constructed for each level in the hierarchy. Then, subtotals of each row in the matrix are calculated in order to have a new set. Overall triangular fuzzy values (li, mi, ui) for criterion Mi is obtained by calculating li/Σ li, mi/Σ mi, ui/Σ ui, (i=1,2,...n). Membership functions, which mean corresponding weights of alternatives in the related matrix, are calculated for each criterion by using these values. They are normalized and final importance weights of each criterion are obtained.

To apply the process depending on this hierarchy, according to the method of Chang’s (1992) extent analysis, each criterion is taken and extent analysis for each criterion, gi is performed on, respectively. Therefore, m extent analysis values for each criterion can be obtained by using following equation 1 (Kahraman, et al., 2004):

$$S_i = \sum_{j=1}^m M_{g_i}^j \otimes \left[\sum_{i=1}^n \sum_{j=1}^m M_{g_i}^j \right]^{-1} \tag{1}$$

Where gi is the goal set (i = 1, 2, 3, 4, 5,, n) and all the gi M (j = 1, 2, 3, 4, 5,,m) are Triangular Fuzzy Numbers (TFNs). The steps of Chang’s analysis can be given as in the following:

Step 1. The fuzzy synthetic extent value (Si) with respect to the ith criterion is defined as equation 1.

Step 2. The degree of possibility of M₂ = (l₂, m₂, u₂) > M₁ = (l₁, m₁, u₁) is defined as equation 2:

$$V(M_2 \geq M_1) = \sup_{y \geq x} [\min(\mu_{M_1}(x), \mu_{M_2}(y))] \tag{2}$$

Step 3. x and y are the values on the axis of membership function of each criterion. This expression can be equivalently written as given in equation 3 below:

$$V(M_2 \geq M_1) = \begin{cases} 1, & \text{if } m_2 \geq m_1, \\ 0, & \text{if } l_1 \geq u_2, \\ \frac{l_1 - u_2}{(m_2 - u_2) - (m_1 - l_1)} & \text{otherwise} \end{cases} \tag{3}$$

4. Case study: Turkey

Turkey, with a fast growing economy and population, has been experiencing substantial demand growth in all segments of the energy sector. This demand is mainly met by importing of energy primarily oil and natural gas. With the enforcement of the Electricity Market Law in 2001, the Natural Gas Market Law in 2001, the Oil Market Law in 2005, Liquefied Petroleum Gases Law in 2005 and the Market Law in 2005, significant steps were taken for the creation of a competitive and functional market in Turkish energy sector. Liberalization which aims to create a competitive environment and to enhance the investment is now being applied under the supervision of the Energy Market Regulatory Authority (EMRA).

In order to reduce the energy import dependency, utilization of renewable energy sources has been supported since 1984. Diversifying the country's natural resource supply and increasing the share of renewable energy sources are at the top of the list of the Turkish Ministry of Energy and Natural Resources' four year strategic plan (2010-2014) (ETKB, 2010). With this aim, first in 2005, The Law on The Utilization of Renewable Energy Resources For The Purpose of Generating Electrical Energy was enacted. By the end of 2010, an amendment to this law (Law number 6094) was done. The main reason of amendment is the reconstruction of the supporting mechanisms (feed-in tariff and purchase guarantee) to increase the investments. With the supporting mechanisms and the developments in the renewable energy technologies, Prime Ministry Undersecretariat of State Planning Organization put a target of increasing the share of renewable resources in electricity generation up to at least 30% by 2023 (DPT, 2009).

To reach the target, maximum use of renewable resources must be ensured. Among the renewable energy resources, wind has been the most popular for the investors. Turkey has a very large potential for wind power. Turkey has a minimum wind energy potential of 5.000 MW in regions with annual wind speed of 8.5 m/s and higher, and 48.000 MW with wind speed higher than 7.0 m/s (REPA, 2007). However, not all of the sites having high wind velocity are suitable for wind farm construction due to several reasons explained in the study. Therefore, it is necessary to evaluate potential sites for wind farm construction by considering using a holistic approach such as proposed in this study.

4.1 Scenario: Alternative sites for wind farm in Turkey

According to the data published on the webpage of the Ministry of Energy and Natural Resources (ETKB), Turkey's installed power for wind energy reached the level of 802.8 MW as of the end of 2009. Upon taking effect of the Renewable Energy Law, licenses were granted to 93 new wind projects which deliver a total installed power of 3.363 MW.

To decrease the time and cost of any feasibility analysis, General Directorate of Electrical Power Resources Survey and Development Administration (EIE) developed a wind map which provides three different numerical atmosphere analysis model combined with meteorological data (Figure 2). For potential wind farm locations, map is integrated to a geographical information system model. This map includes topography, rivers, lakes, civilization areas, special forest terrain, highways, railroads, harbors, airports, energy transmission lines and transformer stations.

REPA also has a map where the wind farms cannot be built for various reasons such as cities, density of population, archeological value, historic value and many more. In Figure 3, the black area shows the place where no wind farms can be built.

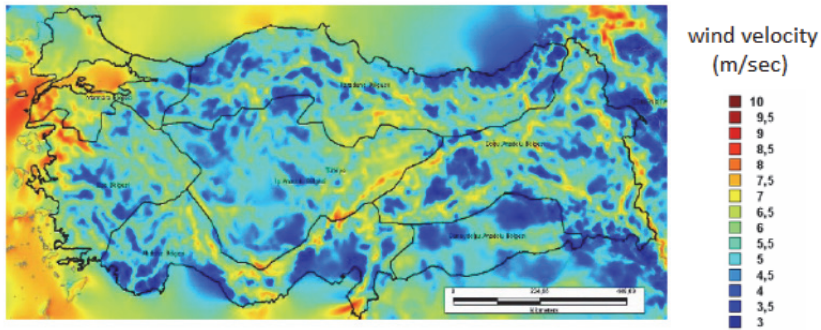

Fig. 2. Average yearly wind velocity distribution of 50 m height (REPA, 2007).

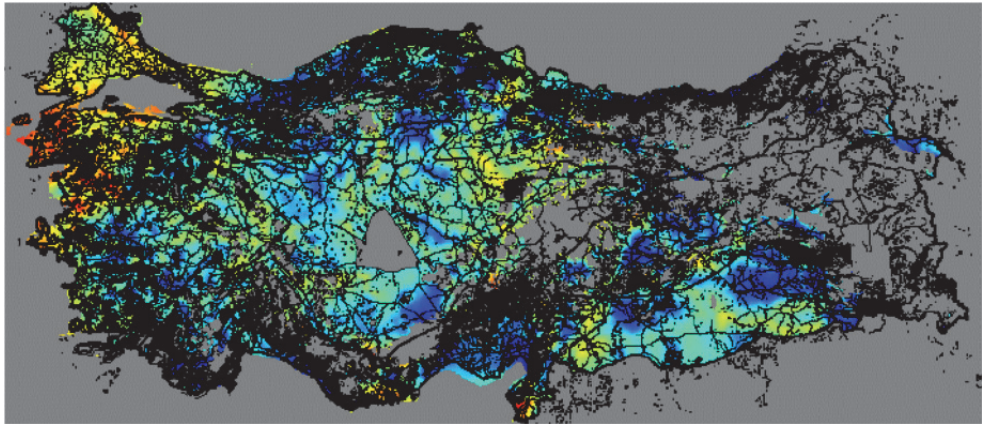

Fig. 3. REPA map of unusable area for wind farm siting (Edremitlioğlu et al., 2007)

Based on the REPA map, it may be concluded that the regions of north Aegean, Marmara and East Mediterranean have high wind energy potential. Annual average wind speed and wind density values for the regions of Turkey were given in Table 1 in order to compare with Figure 2 where wind velocity distribution is given for each point in Turkey.

Region	Annual average wind speed (m/s)	Annual average wind density (W/m^2)
Marmara	3.3	51.9
Southeast Anatolia	2.7	29.3
Aegean	2.6	23.5
Mediterranean	2.5	21.4
Black Sea	2.4	21.3
Central Anatolia	2.5	20.1
East Anatolia	2.1	13.2
Turkey Average	2.5	24.0

Table 1. Wind potential of various regions in Turkey (Erdoğan, 2009).

It is clear that wind distribution map is more meaningful than annual average wind speed data for regions. As a result, wind velocity distribution map should be used in order to determine alternative sites for wind farm construction, and to make decision analysis for selecting the most suitable location among the alternative sites.

It is planned to construct a wind farm that has a capacity of 750 MW according to the strategic plan of ETKB. Based on the Figure 2 and Figure 3, Karaman (Sertavul), İzmir (Bergama), İstanbul (Tuzla) and Muğla (Gökova) are selected as candidate sites for wind farm construction due to their potential wind speed and not being an unusable area. Necessary information about alternative sites were given that would be useful while assessing alternative sites for wind farm construction. However, they must be assessed from much more points of view than wind speed; necessary data must be gathered in order to make evaluation between alternatives by using proposed hierarchy. For this cases study, economical factors of electricity market and incentives and social factors of regulatory boundaries were not considered, since electricity that is produced by each alternative site will be delivered to the central grid system of Turkey. Therefore, electricity market is the same for all of the alternatives. Also, all of them share the same restrictions or the opportunities from the incentives and regulatory boundaries point of view; there is no change region to region for incentives and regulations.

4.1.1 Properties of alternative sites for wind farm construction

Karaman (Sertavul) is located in Central Anatolia of Turkey and have average wind speed of around 7-7.5 m/s (Figure 1) which has the potential of wind power and above the average speed of Turkey. However, land topography and geology is not so suitable to construct wind farm. It is relatively a steeper land and there are high mountains having 2000 m average height round the site. On the other hand, selected area is far away from surface and ground water sources. Although, Karaman has a rich wild life & endangered species; location of candidate wind farm site does not endanger the life of a substantial number of species. Population density is high in the central of city, as a result noise and visual impact may not be considered as an important environmental issue of wind farm due to its being very far away from central of city. In addition, location does not have a beneficial alternative land use such as being an agricultural, touristic or strategic area (URL-1). However, the grid is not so close to wind farm area due to being a relatively isolated area (ETKB, 2010).

Istanbul is located in the south west of Turkey in Marmara Region. Tuzla is located in the Anatolian (Asia) region of the city. Tuzla has an average wind speed of 7-7.5 m/s (Figure 1). Relatively steeper lands and solid rocks are dominant geologic formation in the region. However, sources of groundwater and foundation are spread in the region and precautions have to be taken about the stability of constructions. Tuzla has high population density and boundaries of residential area are extensive. There are lots of industrial estates and zones due to its being close to important transportation means. Visual and noise impact of wind farm become important as a result of the topography and existing layout of the region (residential areas and industries). On the other hand, the region is not rich of wild life and endangered species (URL-2). Alternative land uses are critical for Tuzla, because region is one of the most widely preferred areas for industrial zones and depending on this the demand for residential area close to these zones is high. Tuzla is close to grid and transmission lines (ETKB, 2010).

İzmir (Bergama) is located in the west of Turkey in Aegean Region. There are valleys, mountains and surface water sources in the region. Population density is about tenfold

higher in central of the region than in rural areas. However, there are very steep lands, protected areas due to archaeological heritages in the region and primary seismic zones; selected wind farm site is relatively a plain area, the potential of earthquake is not so high and it is far away from protected areas. There are not wild life and endangered species that must be protected in the site. There is another wind farm site in the region which will provide compatibility of proposed wind farm project with the view of the region. In addition, area is far away from the residential area and noise and aesthetic possibly will not disturb residents of the region (Bergama, 2009). Although proposed site has not any beneficial alternative, it may be attractive for touristic plants due to its being relatively close to touristic areas. Wind speed is about 8-8.5 m/s (Figure 1) in the region and there is a high potential of energy production. Moreover, there is a ready grid to transmit energy to central system very close to site (ETKB, 2010).

Muğla is located in the south west of Turkey in Aegean Region. Wind speed of the region is around 6 m/s (Figure 1) and it is the smallest among the other alternative sites. However, land topography of Muğla is very plain and formation of earth is relatively strong enough for wind farm sitting. Population density of Muğla varies seasonally. Population is heavily crowded in the seaside in summer and low in winter. Wild life and endangered species is a very important environmental aspect for Muğla (URL-3). Noise and visual impact could be neglected, when the existing residential layout which is far away from the site and facilities such as thermic central near the site are taken into consideration. Alternative land use of Bergama is also valid for Muğla, however Muğla has much more problematic facilities in the site which decreases the possibility of alternative land use in the site. There is a grid close to site and structure is compatible with the planned wind farm project (ETKB, 2010).

4.1.2 Application of proposed hierarchy to case study

Four alternative sites for wind farm sitting are evaluated based on the necessary information given about sites and scenario by using the methodology explained. All of the factors in the same level were compared with each other by using the scale (Table 2) formed in order to make pair-wise comparison. Comparisons are made based on the priority of the factor relative to the other factor being compared.

Evaluation is made by the authors of the study who have background of environmental, chemistry, energy systems and industrial engineering and business administration. Therefore, expert opinions on technical, economic, environmental and social factors could be provided. For further applications, contributions of experts on earth science and social science and representatives of non-governmental organizations are advised in order to have an extended analysis of decision making on real-time issues.

An individual score must be given for each factor comparison by discussing and sharing the knowledge about factors in order to have a holistic evaluation. Based on the scores given for comparison, synthetic numbers were formed by using equation 1 and minimum ones were chosen by using equation 2. Priority numbers of factors were derived from normalized synthetic results (Table 3). Secondly, alternatives are compared based on each sub factor in order to have priority numbers of alternatives which are specific to factor considered. These priority numbers were obtained by following the same procedure explained above. For the overall results, in which priority number for the alternatives are obtained, priority numbers of the alternatives for each factor is aggregated after multiplying it with the priority number of the related factor.

Intensity of Importance	Triangle Fuzzy Number
Very low	(1/9, 1/9, 1/7)
Low	(1/9, 1/7, 1/5)
Moderately Low	(1/7, 1/5, 1/3)
Moderate Low	(1/5, 1/3, 1)
Just equal	(1, 1, 1)
Moderate High	(1, 3, 5)
Moderately High	(3, 5, 7)
High	(5, 7, 9)
Very High	(7, 9, 9)

Table 2. Triangle Fuzzy Number for Intensity of Importance

4.1.3 Results and discussion

First group of results, which are related with the priority of factors for site selection, are more general than others. They have been scored by considering general aspects related with the aim. According to the results given in Table 3, among the factors effecting the wind farm site selection, environmental (0.33) and social ones (0.29) are mostly effective.

Technical factors are relatively close to social factors; however economic factors have the least priority from site selection point of view. All of the production and service facilities must ensure the sustainability of life and environment. Selection of a project that costs very low in spite of harming environment and society should not be allowed. Technical and economic feasibility must be optimized based on the restrictions of environmental and social sustainability. Damage on wild life and endangered species and electromagnetic interference have the same and highest priority (0.32) for selection due to their being irreparable injuries. Noise and visual impact is relatively tolerable (0.19 and 0.18, respectively) than other environmental effects, because there are precautions that can be taken during or after wind farm construction.

Land use is the most important social factor (0.45), since there is a need for big lands in order to construct wind farm and these lands may be used for much more beneficial purposes such as agriculture, tourism or strategic. Distance to residential area must be considered seriously due to its effect on society both during and after the construction. If environmental and other social factors are sustained, public acceptance will also be provided mostly. Therefore, its direct effect on the site selection become as least effective social factor.

Among technical sub factors, wind speed and grid structure and distance have the highest priority (0.31) due to their effects on energy efficiency, capacity factor and being ever ready. On the other hand, land topography and geology (0.25) determines the stability of the wind turbines and technical feasibility of their construction. Also, turbine size does not have a direct contribution to technical feasibility (0.13), required turbine size for the planned capacity would be restricted with alternative suppliers of turbine generators and available land resources.

Capital cost is the most distinguishing factor (0.46), because it is known that capital cost is the biggest contributor of total cost due to high construction and turbine costs. However, need of large area makes land cost as important as capital cost and varies region to region dramatically. Although operational & management costs varies with region, its contribution

to total cost is mostly very small which include the expenses of the employees and maintenance of equipment in general.

Factors	S number Eq 2	$\min V(S_i > S_j)$ Eq 3	Priority normalization
Technical Factors	[0.06, 0.19, 0.71]	0.73	0.24
Wind Speed	[0.19, 0.5, 1.33]	1	0.31
Land Topography & Geology	[0.05, 0.16, 0.49]	0.8	0.25
Grid Structure & Distance	[0.08, 0.26, 0.80]	1	0.31
Turbine Size	[0.04, 0.07, 0.22]	0.43	0.13
Economic Factors	[0.04, 0.08, 0.36]	0.44	0.14
Capital Cost	[0.15, 0.54, 1.67]	1	0.46
Land Cost	[0.11, 0.34, 1.06]	1	0.46
O&M Cost	[0.07, 0.12, 0.23]	0.16	0.07
Environmental Factors	[0.1, 0.42, 1.43]	1	0.33
Visual Impact	[0.05, 0.16, 0.49]	0.56	0.18
Wild Life & Endangered Species	[0.14, 0.43, 1.19]	1	0.32
Electromagnetic Interference	[0.06, 0.16, 0.47]	1	0.32
Noise Impact	[0.06, 0.17, 0.53]	0.6	0.19
Social Factors	[0.08, 0.37, 1.07]	0.9	0.29
Public Acceptance	[0.07, 0.13, 0.45]	0.42	0.19
Land Use	[0.15, 0.54, 1.67]	1	0.45
Distance to Residential Area	[0.11, 0.34, 1.06]	0.81	0.36

Table 3. Calculating the priority numbers by Chang Model

Detailed results of calculations for each alternative are shown in Table 4. Priority numbers of the alternatives for each main factor is shown in Figure 4. From environmental point of view, Karaman and İzmir has the same and highest priority as a candidate for wind farm sitting. İzmir is one of the preferable regions due to its having very small number of wild life and endangered species and being relatively isolated from the electromagnetic interference potential. Moreover, location of the selected site has a low potential of visual and noise impact. Although wild life and endangered species are relatively rich in Karaman, it is also the most preferred site based on environmental factors due to its being isolated from residential area which leads to low noise and visual impact.

Although İstanbul is the most preferred site because of being poor in number of wild life and endangered species, it is the least preferred site from other environmental points of view due to high number of industrial zones and its being close to residential area. However, Muğla is moderately preferred based on visual, noise impact and electromagnetic interference, richness of wild life and endangered species near the candidate location make Muğla one of the two least favourable site based on environmental issues.

Karaman									
	S number	minV (Si>S)	P*	S number	minV (Si>S)	P	S number	minV (Si>Sj)	P
Technical Factors									
WS	[0.17, 0.61, 1.88]	0.75	0.35	[0.17, 0.39, 1.13]	0.39	0.18	[0.73, 1.00, 1.56]	1	0.47
GD	[0.08, 0.16, 0.52]	0.20	0.08	[0.17, 0.44, 1.25]	0.63	0.26	[0.31, 1.00, 2.81]	1	0.41
L7G	[0.08, 0.16, 0.52]	0.20	0.08	[0.13, 0.39, 1.25]	0.61	0.23	[0.17, 0.61, 1.88]	0.80	0.31
TS	[0.17, 0.61, 1.88]	0.63	0.24	[0.13, 0.22, 0.63]	0.41	0.16	[0.21, 0.83, 2.50]	1	0.39
Economic Factors									
CC	[0.08, 0.16, 0.52]	0.29	0.10	[0.21, 0.83, 2.50]	1	0.33	[0.13, 0.39, 1.25]	0.70	0.23
LC	[0.31, 1.00, 2.81]	1	0.40	[0.12, 0.38, 1.15]	0.57	0.23	[0.17, 0.44, 1.25]	0.63	0.12
OMC	[0.17, 0.61, 1.88]	0.88	0.35	[0.08, 0.17, 0.63]	0.51	0.20	[0.13, 0.39, 1.25]	0.12	0.05
Environmental Factors									
VI	[0.31, 1.00, 2.81]	1	0.42	[0.08, 0.16, 0.52]	0.02	0.08	[0.17, 0.44, 1.25]	0.63	0.26
WL	[0.13, 0.39, 1.25]	0.61	0.23	[0.31, 1.00, 2.81]	1	0.38	[0.17, 0.61, 1.88]	0.80	0.31
EI	[0.17, 0.61, 1.88]	0.97	0.30	[0.08, 0.17, 0.63]	0.45	0.14	[0.21, 0.67, 1.88]	1	0.31
NI	[0.23, 0.56, 1.56]	1	0.29	[0.08, 0.16, 0.52]	0.42	0.12	[0.21, 0.67, 1.88]	1	0.29
Social Factors									
PA	[0.17, 0.61, 1.88]	0.88	0.28	[0.08, 0.17, 0.63]	0.38	0.12	[0.21, 0.83, 2.50]	1	0.32
LU	[0.31, 1.00, 2.81]	1	0.38	[0.08, 0.16, 0.52]	0.20	0.08	[0.17, 0.61, 1.88]	0.80	0.31
DRA	[0.31, 1.00, 2.81]	1	0.36	[0.09, 0.16, 0.52]	0.20	0.07	[0.17, 0.44, 1.25]	1	0.36

* Priority Number

Table 4. Comparison results of sub-factors for Chang's Analysis

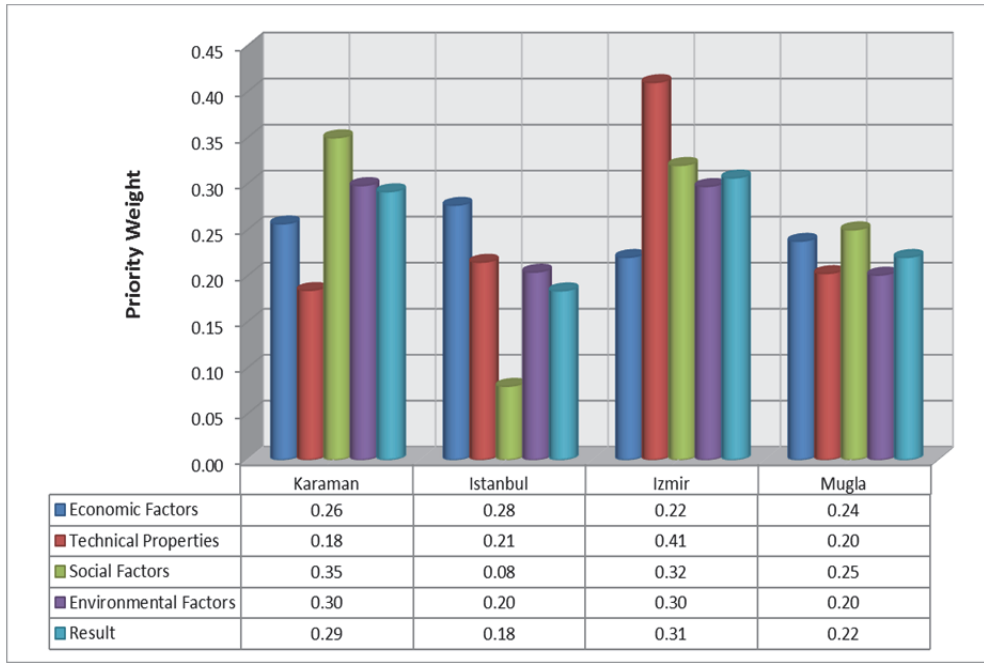

Fig. 4. Priority weights of each factor for the alternatives

Social factors lead to selection of Karaman as most appropriate site (0.35) for wind farm project. Expectation of society to become a developed city results in the acceptance of such an energy production project which is already does not cause serious environmental problems. In addition, there is no alternative beneficial use for the land and residential area is far away from the site. Same reasons are valid for Izmir which has about the same priority number (0.32) with Karaman.

For Muğla, public acceptance and alternative land uses are critical. Muğla has a thermal power plant and against to the further projects around the region. Istanbul is certainly the least preferred site due to social factors. High potential of being an industrial zone bring the alternative land use in the foreground and public acceptance become restricted due to both alternative land use and environmental impacts. Also, being a dense residential area is a big disadvantage that cannot be tolerable in any way.

Izmir is a distinguished alternative from technical points of view. Average wind speed is higher than the other sites and there is a close grid in the site serving for another wind farm. Therefore, its turbine size is small as possible as due to high wind speed and there is no restriction about the suppliers. Land topography and geology is relatively make it hard to construct a wind farm, however it can be overcome relatively easier due to existing experiences about wind farm construction in the site.

Istanbul, Muğla and Karaman have almost the same priority number for technical factors which are 0.21, 0.20 and 0.18, respectively. Although average wind speed is relatively high in Karaman and there is no debate about turbine size due to large available area, long distance between wind farm and grid in Karaman and construction problems due to land topography and geology cause Karaman to be in the last order based on technological factors. Muğla also has low priority due to low wind speed and high turbine size which need large area. Low wind speed and especially the availability of wind reduce the electability of Istanbul.

Economic priorities of the sites are very close to each other. Istanbul is the most advantageous city from economic point of view due to low capital cost need which has the highest share in the total cost. There are lots of construction firms in Istanbul and land topography and geology is not so hard in Istanbul for construction. Most of the construction equipment is readily available and the need of construction of extra roads, equipment storage areas etc. are minimum owing to existing infrastructure.

Muğla also have the same advantageous for capital cost. Land cost is lowest in Karaman and highest in Muğla where public acceptance is doubt and alternative use of the site is possible. Muğla and Karaman have the lowest operational and maintenance cost due to cheap work force.

When all of the priority numbers of each alternative are aggregated, results shown in Figure 5 are achieved. Izmir is the most preferred site for wind farm construction and Karaman has around the same priority number with the Izmir. They have almost the same characteristics for environmental, social and economic factors, however wind speed of Karaman is lower than Izmir and grid distance is much closer in Izmir than it is in Karaman. As priorities of technological factors are lower than priorities of environmental and social factors; there is not a big difference between Izmir and Karaman to construct wind farm.

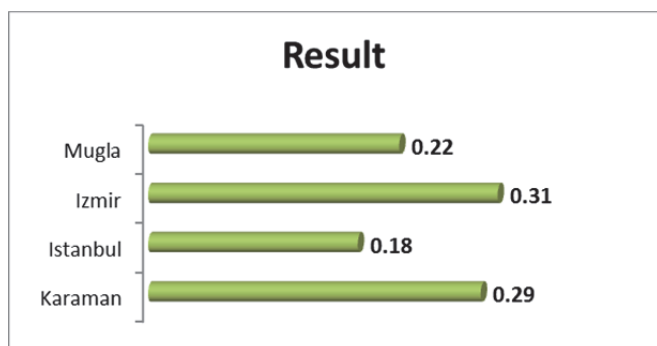

Fig. 5. Priority weights of alternatives

Methodology provides the decision maker to make extended analysis of results based on the priorities of alternatives specific to factors. Decision maker can determine a critical factor to give decision and select the site by considering the priority of the site based on this factor.

For example, Karaman can be selected due to its higher priority for economic and social factors rather than Izmir.

Moreover, Karaman and Izmir can be analysed in detail which is not possible for more than two alternatives from economic and social point of view. Muğla and Istanbul, which has low priority for environmental, social and technical point of view, is certainly must be eliminated according to the results.

5. Conclusion

Wind energy has become widely used in recent years in order to increase the usage of renewable energy sources instead of fossil fuels or nuclear energy. Therefore, wind farm site selection is a vital issue that must be analysed deeply in order to have efficient wind power generation from technical and economic point of view without damaging environment and society. However, there are lots of factors that make contribution to selection of wind farm site and they must be organized with a systematic hierarchy in order to make decision with a holistic approach. Also, uncertainties could appear about the effects of these factors. Due to these reasons, Chang's extent analysis of FAHP is a proper method for decision making on wind farm site.

This methodology provides three groups of the result which are priority numbers of the factors based on the wind farm site selection, priority numbers of the candidate sites specific to each factor and aggregated priority number of each alternative based on all of the factors affecting wind farm selection. Therefore, methodology offers a number of advantages for analysing the wind farm site selection deeply.

First of all, it enables the user to identify the source of the problem related with the inappropriateness of the site owing to priority numbers of the site specific to each factor. Secondly, priority numbers of the factors based on the wind farm site selection give the opportunity of reflecting the importance weight of the factor on site selection in quantitative assessments. Overall results provide to distinguish the alternatives from each other and reduce the number of alternatives especially for further detailed decision analysis.

Technical, economic, environmental and social factors are the main factors contributing site selection problem. Environmental and social factors are distinctive ones that distinguish technically and economically feasible sites. Different alternatives could be the most suitable area for wind farm according to different factors. Composing of these factors gives the most suitable site according to combined effect of factors.

6. References

- American Wind Energy Association (AWEA). (2007). *10 Steps in building a wind farm*. 17.02.2011, Available from <http://www.awea.org/pubs/factsheets.htm>
- Baban, S. & Parry, T. (2001). Developing and applying a GIS-assisted approach to locating wind farms in the UK, *Renewable Energy*, Vol. 24, pp. 59-71, ISSN 0960-1481
- Bergama Municipality, (2009). 2010-2014 Strategic Plan. 13.01.2011 Available from <http://www.bergama.bel.tr/Dokumanlar/2010-2014stratejikplan.pdf>

- Bright, J.; Langston, R.; Bullman, R.; Evans, R.; Gardner, S. & Pearce-Higgins, J. (2008). Map of bird sensitivities to wind farms in Scotland: A tool to aid planning and conservation. *Biological Conservation*, Vol. 141, pp. 2342-2356, ISSN 0006-3207
- Brower, M. (1992). *Cool energy: Renewable solutions to environmental problems*, MIT Press, Cambridge, ISBN 0262023490.
- Cavallaro, F. & Ciruolo, L. (2005). A multicriteria approach to evaluate wind energy plants on an Italian island, *Energy Policy*, Vol. 33(2), pp. 35-44, ISSN 0301-4215
- Chang, D.Y., 1992. Extent analysis and synthetic decision. *Optimization Techniques and Applications*, 1. World Scientific, Singapore, Vol. 1, p. 352.
- Clark, J. G. (1991). *The political economy of world energy: A twentieth-century perspective*, Chapel Hill, North Carolina, USA, ISBN 0807819441
- Edremitlioglu, H. H.; Toydemir, C. K. & Başkan, O. (2007). Economical, Environmental Outcomes of Wind Energy Production in Turkey. Qualifying Project for the degree of Bachelor of Science
- Erdoğan, E. (2009). On the wind energy in Turkey. *Renewable and Sustainable Energy Reviews*, Vol. 13, pp. 1361-1371, ISSN 1364-0321
- European Wind Energy Association (EWEA). (2009). *Wind Energy-The Facts*, ISBN 9781844077106, Earthscan, UK
- Herbert G. M. J.; Iniyar S.; Sreevalsan, E. & Rajapandian S. (2007). A review of wind energy technologies. *Renewable and Sustainable Energy Reviews*, Vol. 11, pp. 1117-45, ISSN 1364-0321
- Kahraman, C., Cebeci, U. & Ruan, D. (2004). Multi-attribute comparison of catering service companies using fuzzy AHP: the case of Turkey, *International Journal of Production Economics*, Vol. 87, pp. 171-184, ISSN 0925-5273
- Kaya, T. & Kahraman, C. (2010). Multicriteria renewable energy planning using an integrated fuzzy VIKOR & AHP methodology: The case of Istanbul, *Energy*, Vol. 35, pp. 2517-2527, ISSN 0360-5442
- Kikuchi, R. (2008). Adverse impacts of wind power generation on collision behavior of birds and anti-predator behavior of squirrels. *Journal for Nature Conservation*, Vol. 16, pp. 44-55, ISSN: 1617-1381
- Kusiak, A. & Song, Z. (2010). Design of wind farm layout for maximum wind energy capture. *Renewable Energy*, Vol. 35, pp. 685-694, ISSN 0960-1481
- Lee, A. H. I.; Chen, H. H. & Kang, H. Y. (2009). Multi-criteria decision making on strategic selection of wind farms, *Renewable Energy*, Vol. 34, pp. 120-126, ISSN 0960-1481.
- Manwell, J.F.; McGowan, J.G. & Rogers, A.L. (2002). *Wind Energy Explained: Theory, Design and Application*, John Wiley&Sons, ISBN 0-471-49972-2, UK
- Munday, M.; Bristowb, G. & Cowell, G. (2011). Wind farms in rural areas: How far do community benefits from wind farms represent a local economic development opportunity?, *Journal of Rural Studies*, Vol. 27, pp. 1-12, ISSN 0743-0167

- Ozerdem, B.; Ozer, S. & Tosun, M. (2006). Feasibility study of wind farms: A case study for Izmir, Turkey. *Journal of Wind Engineering and Industrial Aerodynamics*, Vol. 94, pp. 725-743, ISSN 0167-6105
- Republic of Turkey- Prime Ministry Under secretariat of State Planning Organization (DPT). (2009). *Electricity Energy Market and Supply Security Strategy Paper*, 13.11.2010. Available from http://www.enerji.gov.tr/yayinlar_raporlar_EN/Arz_Guvenligi_Strateji_Belgesi_EN.pdf
- Saaty, T. L. (1980). *The Analytical Hierarchy Process*, Mc Graw Hill, New York.
- Taha, H. A., (2003). *Operations Research*, Pearson Education Inc., Fayetteville, ISBN 0131429159
- Tegou, L. I.; Polatidis, H. & Haralambopoulos, D. A. (2010). Environmental management framework for wind farm siting: Methodology and case study. *Journal of Environmental Management*, Vol. 91, pp. 2134-2147, ISSN 0301-4797
- The Republic of Turkey Ministry of Energy and Natural Resources (ETKB). (2010). *Strategic Plan (2010-2014)*, 24.12.2010, Available from http://www.enerji.gov.tr/yayinlar_raporlar_EN/ETKB_2010_2014_Stratejik_Planı_EN.pdf
- Turkey Wind Energy Potential Atlas (REPA). (2007). 12.11.2010 Available from <<http://repa.eie.gov.tr>>
- Twidell, J. & Weir, T. (2006). *Renewable Energy Resources*. Taylor&Francis, 2nd Edition, ISBN 978-0-419-25330-3, UK
- Ucar, A. & Balo, F. (2009). Evaluation of wind energy potential and electricity generation at six locations in Turkey. *Applied Energy*, Vol. 86, pp. 1864-1872, ISSN 0306-2619
- UNDP, Serbia. (2010). Guidelines on the environmental impact assessment for wind farms. 05.12.2010 Available from http://www.unece.org/env/eia/documents/EIAGuides/Serbia_EIA_windfarms_Jun10_en.pdf
- Url-1 <<http://www.larende.com/default.asp?islem=k&islemx=cografya&islemx=ibo>>
- Url-2 <http://www.tuzla.gov.tr/default_B1.aspx?content=1>
- Url-3 <<http://www.mugla.gov.tr/>>
- Van der Horst, D. & Toke, D. (2010). Exploring the landscape of wind farm developments; local area characteristics and planning process outcomes in rural England. *Land Use Policy*, Vol. 27, pp. 214-221, ISSN 0264-8377
- Vanek, F. M. & Albright, L. D. (2008). *Energy Systems Engineering-Evaluation and Implementation*. McGraw-Hill, ISBN 978-0-07-149593-6, USA.
- Weisser, D. & Garcia, R. S. (2005). Instantaneous wind energy penetration in isolated electricity grids: concepts and review, *Renewable energy*, Vol. 30 (8), pp. 1299-1308, ISSN 0960-1481
- Welch, J. & Venkateswaran, A. (2009). The Dual Sustainability of Wind Energy. *Renewable and Sustainable Energy Reviews*, Volume 13, Issue 5, pp. 1121-1126, ISSN 1364-0321

- Yue, C. D. & Wang, S. S.; 2006. GIS-based evaluation of multifarious local renewable energy sources: a case study of the Chigu area of southwestern Taiwan, *Energy Policy*, Vol. 34, pp. 730-742, ISSN 0301-4215
- Zhang, Z. X. (2007). China is moving away the pattern of “develop first and then treat the pollution. *Energy Policy*, Vol. 35, pp. 3547–3549, ISSN 0301-4215