

AUTOMATIC LIGHT CONTROLLER FOR CARPORT

MY WIFE WORKS EVENINGS AND GETS home well after dark. Because no one is at home to greet her upon her return, we used to leave the carport light on for many energy-wasting hours, just so she could avoid tripping over bicycles or stepping on the dog's tail when she returned in the evening.

To save my marriage—and conserve electricity—I devised the following circuit. It is simply a 555 timer IC, operating in the one-shot mode, that is triggered by light striking photoresistors. These normally have a resistance of several megohms but, in the presence of light, that resistance drops to several hundred ohms, permitting current from the six-volt source to flow in the circuit. The R-C combination shown gives an on-time of about two minutes. Photoresistors PC3 and PC4 are mounted at headlight-height on the carport wall (one for each of our two cars).

Now, when my wife pulls into the car-

port at night, the headlights illuminate the photoresistor, and the timer starts. That actuates a relay, RY1, in parallel with the carport light switch, and the lights are turned on long enough for her to get safely into the house. The lights are automatically turned off when the timer's two minutes are up.

We also have a push-button switch mounted inside the house and, when we go out at night, that allows us to turn on the outside lights to see our way out to the car, knowing they'll turn themselves off after we've left.

Photoresistors PC1 and PC2 are mounted on the outside of the house where they are in the sun much of the time. That keeps the timer from triggering during daylight hours. Resistors R1 and R2 establish the thresholds for proper on/off control.

My unit has been in service for over a year and has not given me any problems. I've also installed quite a few of these for friends, and they are pleased as can be.

All the components used are stock items.—Ronald Picard

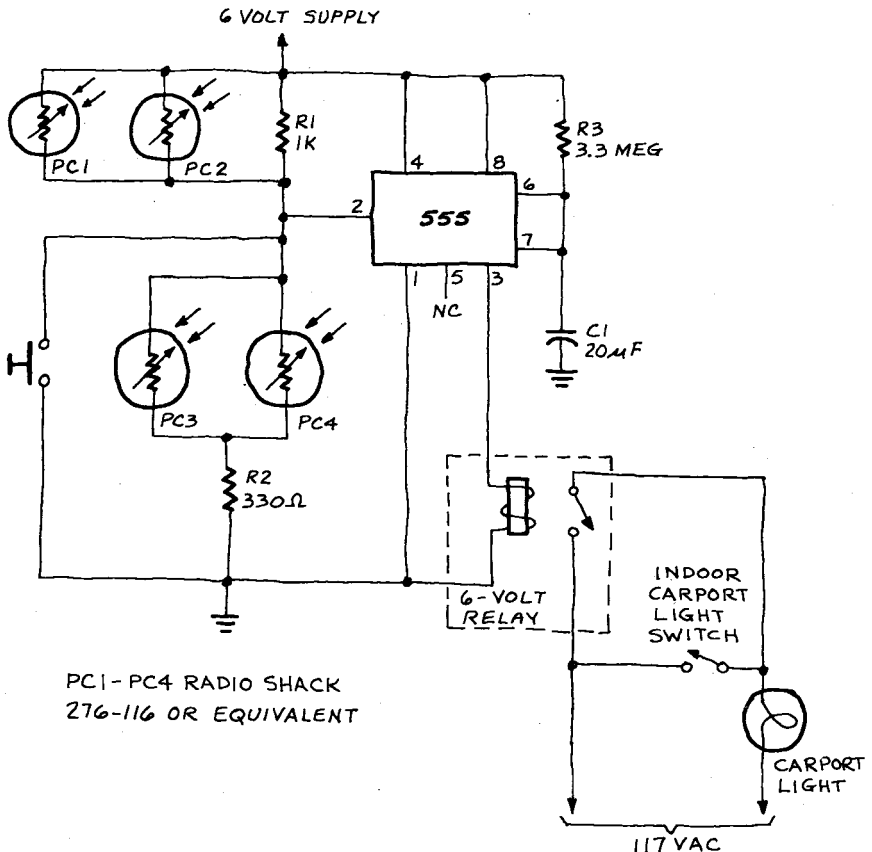

FIG. 1