

Stabilized Power Supplies Part 3

More hands-on practice with two regulated power supplies.

STEVE KNIGHT

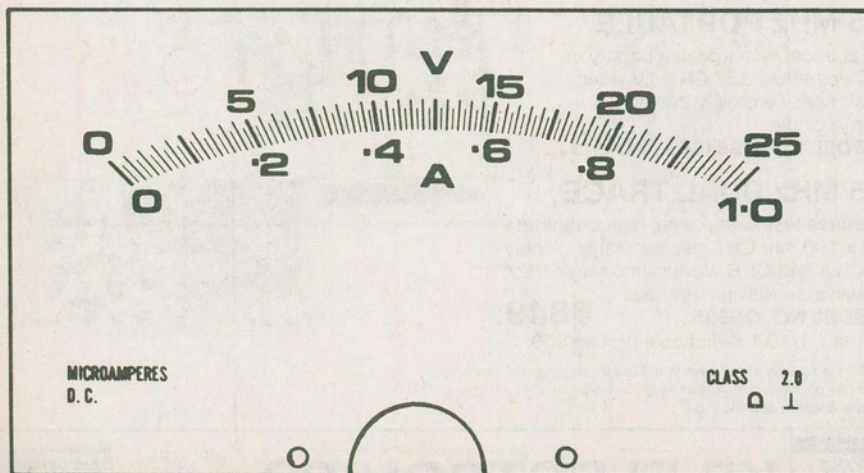
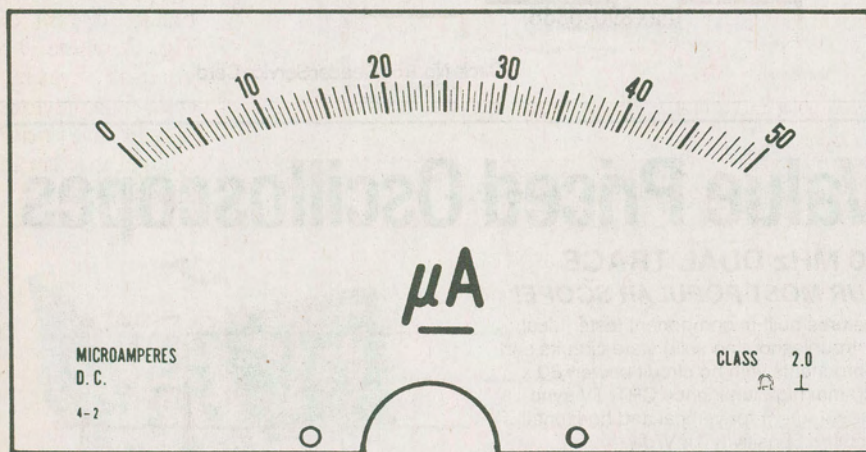

Fig. 1. Meter scaling before (top) and after modification (bottom). The top figures are removed, as well as the μA marking.

Two regulated power supplies with current limiting, one providing 0 to 25V at 700mA and the other 0 to 30V at 1.0A, are our subjects this month. Before getting on with the constructional details, however, a few words about the meters used on these projects won't be out of place.

The addition of a voltmeter/ammeter indicator to any power unit, although not strictly necessary, really completes the job and gives it a more professional finish. Of course, it is always possible to calibrate the voltage control knob on the panel with voltage markers, and since for a stabilized supply there is negligible variation in the output voltage within the specified current range, this is an inexpensive alternative. If cost is also in mind, a single voltmeter can be fitted; this will indicate gross current overloads by either falling to zero on short-circuited loads or failing to increase when the normal current has been exceeded.

The thing to try to avoid is rescaling a meter which has a scale marked in a completely different fashion from what is actually wanted. This *can* be done and the author has rescaled many, but it is a job that requires some skill and a whole lot of patience in removing an existing scale without damaging the instrument itself and some reasonable artistry in marking the new scale to its proper divisions.

Meter

In both this month's designs, a 50 μA meter, has been used. This is a large meter measuring 110mm X 83mm and the scale, as provided, is marked (naturally) 0-50 μA .

The scale changes needed are fairly simple to carry out, but don't under any circumstances do this on a dirty bench top or anywhere else where there are iron filings or other pieces of eager minutiae waiting to get into the moving-coil mechanism and jam everything solid. Find yourself a dust free corner away from the wife, kids and the dog; then carefully remove the plastic covering and put it to one side.

Equally carefully remove the two scale fixing screws and *slide* the scale from beneath the pointer. Now put the meter and the two screws inside the plastic cover and put the lot in a safe place.

Meter Scale

The first of this month's project's needs a scale reading 0-25V and 0-1A, and Fig. 1a and Fig. 1b show the scale before modification and afterwards. You need instant lettering with figures that reasonably match those already in the scale.

The existing μA marking and scale

figures have now to be removed; this is best done by *gently* scraping them with a used razor blade, keeping the blade at right angles to the surface and avoiding "digging in" the corner of the blade. This sounds as though we are going to end up with a patchy surface but with the necessary patience the scale print will come off and leave the underlying white surface undisturbed.

Practise on the small unimportant printing at the foot of the scale first. Then get rid of all the dust and add the V and A lettering and the additional numbering as shown in Fig. 1b. You then have a scale reading 0-25V and 0-1A.

For the second project we need a scale reading 0-30V and 0-1A. Here the voltage scale doesn't fit readily into the existing divisions, so we leave the 0-50 markings as they are and add only the current figures 0-1A in exactly the same way as before. True, we shall only be using three-fifths of the scale length for our 30V output, but these scales are quite large

and easily read so this is no great hardship.

Reassemble the scale on to the meter, taking care that the screws don't fall into the works, and snap the cover back into place. Do this at the bottom first so that the zeroing button engages properly. It should do this without adjustment if you haven't disturbed it.

You can if you wish use a smaller 50uA version of this meter, the type T21, and modify the scale in the same way. If you don't fancy rescaling meters in this way, use separate meters for voltage and current. The 1A type T30 and the 30V type T43 are suitable.

Regulated Supplies

Both projects to be described are very similar in construction and apart from a few minor details, the assembly instructions which follow can apply equally to both designs. Both circuits use discrete transistors, four in the case of the 25V unit and six in the case of the 30V unit.

Some might think that the circuits are retrograde in that they are not using integrated packages, but apart from fairly expensive regulator ICs, the performance figures for these designs are better than those obtainable from integrated systems. Also, few external components are saved by their use and additional circuitry is nearly

always required to get the output voltage range from IC regulators down to zero.

Both circuits operate on the principles shown in the block diagram of Fig. 2 where the various parts covered in previous issues are now brought together in practical form.

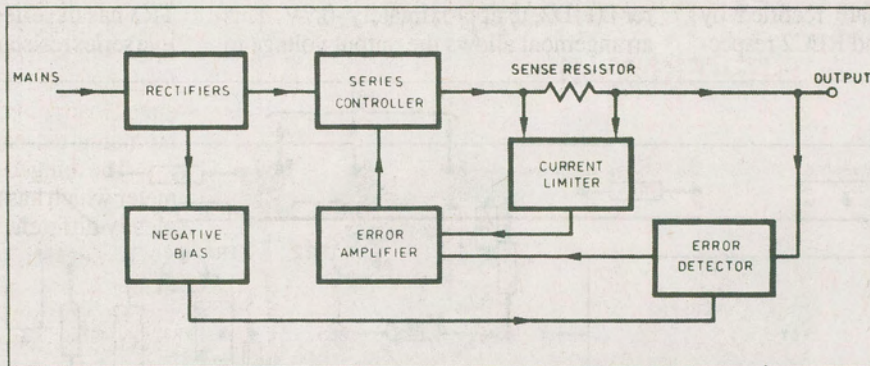

Fig. 2. The general block diagram for the two stabilized supplies.

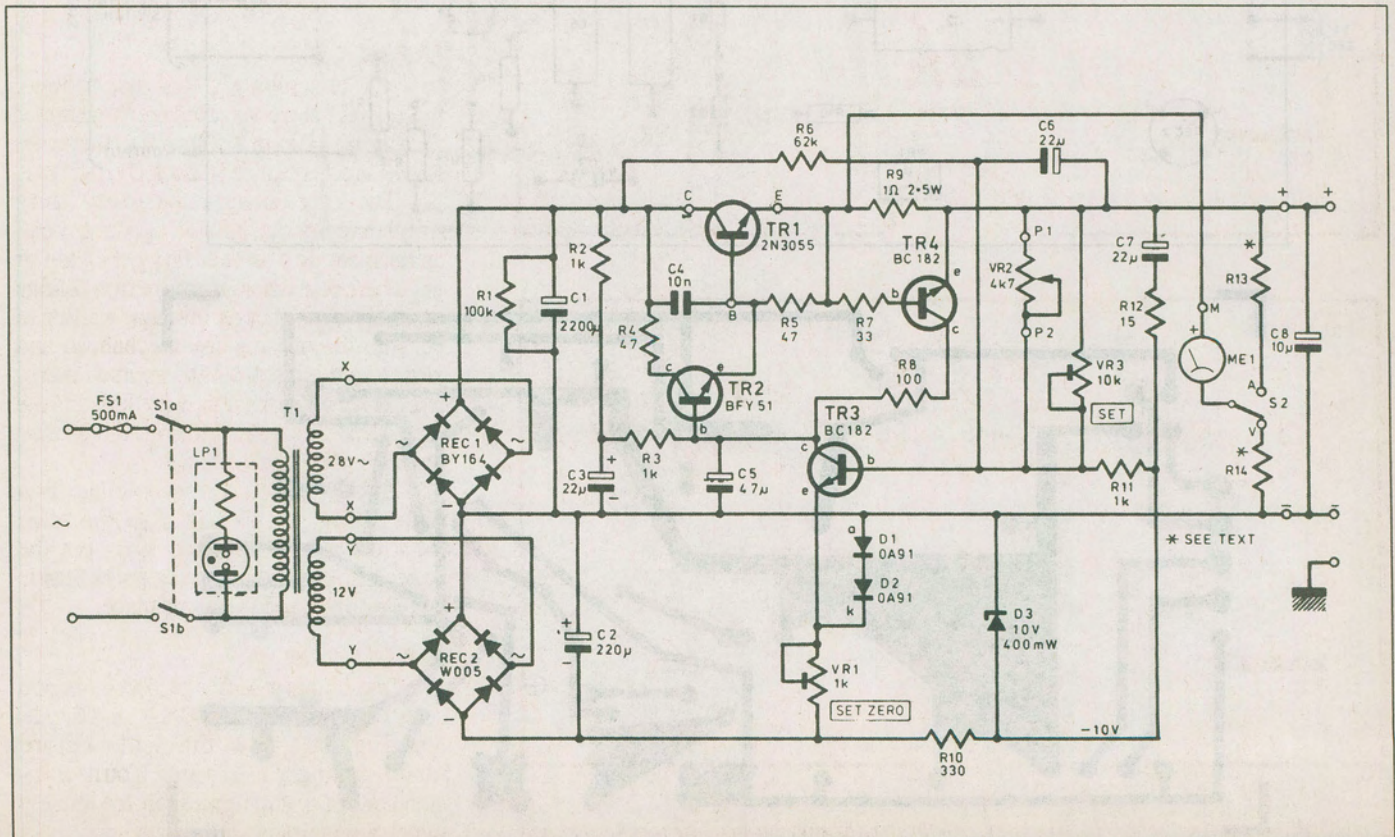

Fig. 3. Circuit diagram for the 25V 700mA variable stabilized supply. Capacitor C8 is mounted across the output terminals.

VARIABLE STABILIZED POWER SUPPLY 0-25V at 700mA maximum, ripple less than 3mV RMS

The circuit diagram for the 0-25V Stabilized Power Supply is shown in Fig. 3. This design will provide a highly stabilized output adjustable from 0 to 25V at a maximum current of 700mA and with a ripple of less than 3mV RMS at full load. The output impedance is one ohm, D.C. to 80kHz.

The power input is derived from transformer T1 which has two secondary windings, one of 28V at a current rating of 1.5A and the other of 12V at a rating of 100mA. Both of these supplies are rectified by bridge rectifiers REC1 and REC2 respec-

tively. After smoothing by capacitor C1, the positive supply line from REC1 goes on through the series regulator transistor TR1, a 2N3055 (or a 2N3771 may be used), and the current sense resistor R9 to the positive supply output terminal.

The output from bridge rectifier REC2 provides, after smoothing by capacitor C2, a negative line which supplies the zener reference diode D3 and also biases the emitter of the error detector D1, D2, to approximately -0.7V. This arrangement allows the output voltage to

be taken down to zero.

The series regulator transistor Tr1 carries the whole of the output current and acts as an automatic resistance. Its base current is controlled by the error amplifier TR2 which amplifies the output from the error detector TR3 to a level sufficient to drive the base of TR1.

Base bias for TR1 and collector bias for TR2 are provided by resistor R4. Hence, whatever happens at the base of TR3 has the effect of adjusting the effective series resistance of TR1.

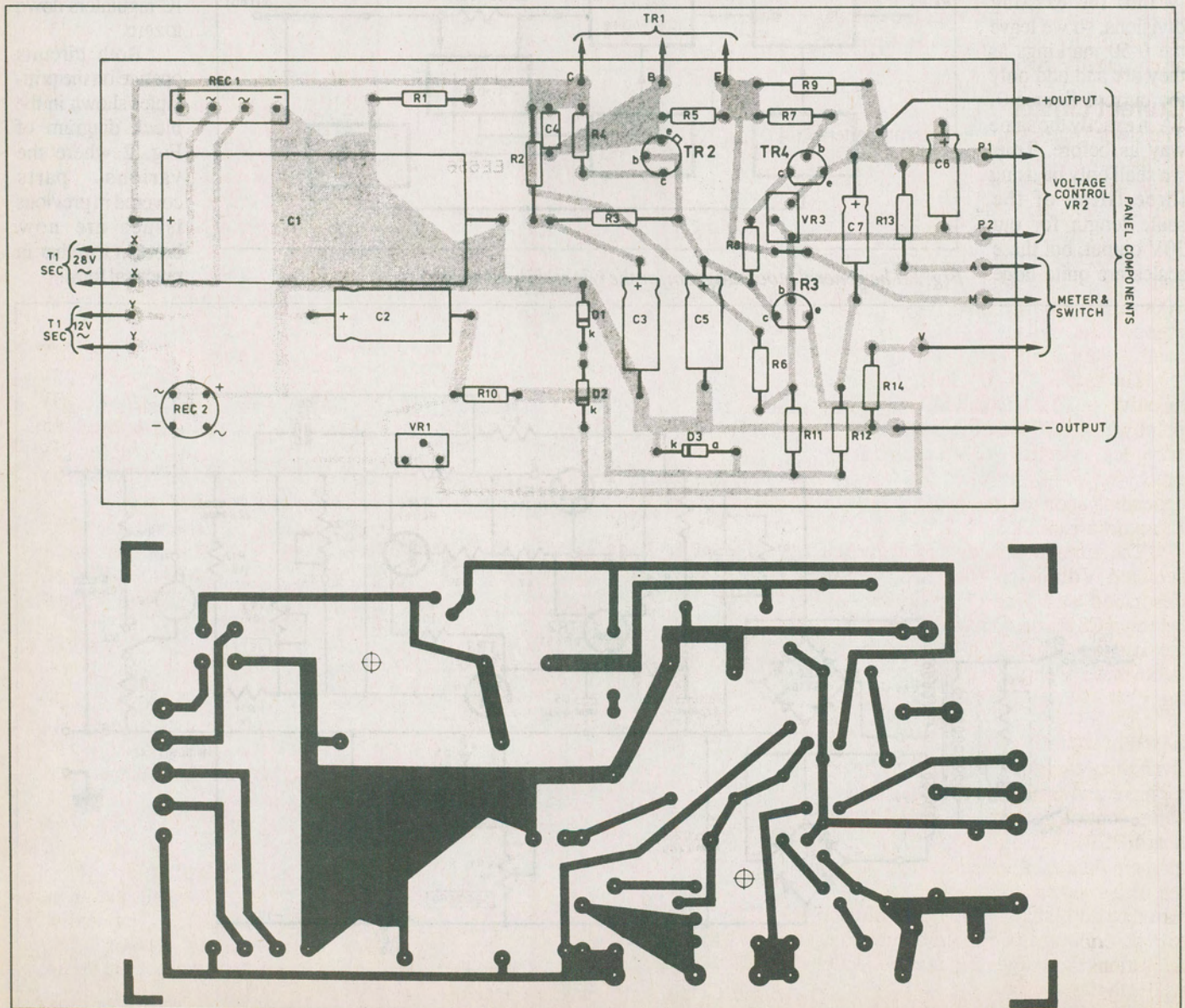

Fig. 4. PCB component layout and full sized copper foil pattern. Drill mounting holes to suit mounting spacers.

The base of TR3 connects to the voltage adjusting potentiometer VR2. The control sets the required output voltage to anything between 0V and 25V. Once this is set, any unwanted variation in the output level is passed to the base of TR3 and initiates the feedback to TR1.

Suppose the output tends to fall slightly. The voltage at the base of TR3 falls and its collector current (derived through resistors R2-R3) also falls. This increases the base current of TR1. This reduces the resistance of TR1 and the output fall is compensated.

This regulation also acts to reduce the output ripple voltage; any ripple on the rectifier side of transistor TR1 is passed by way of resistor R6 to the base of the error detector (TR3), and this, together with capacitor C6 effectively bypassing VR2 to AC ripple components in the output, enables the feedback to treat the ripple as an unwanted variation.

Current Limiter

Transistor Tr4 serves as the current limiter. Its base-emitter bias is derived from the voltage developed across the series resistor R9. Providing that this voltage is less than about 0.7V, TR4 remains switched off.

The value of resistor R9 is one ohm and when the output current reaches 700mA, the voltage drop is 0.7V. This then switches transistor TR4 on and takes control away from the error detector TR3.

The base of Tr2 consequently moves negative and TR1 is biased back to the point where a 700mA current cannot be exceeded. In actual practice, the current limit may lie between 650 and 750mA, depending upon the tolerances of resistor R9 and transistor TR3.

The output is monitored by the switch selected Voltmeter/Ammeter already described and finally smoothed by capacitor C8. Preset controls VR1 and VR3 are used to set up the voltage limit reading on the meter when the unit is ready for testing.

Construction

Everything except the mains transformer, the meter and its switching, and the voltage adjust control, goes on to a printed circuit board (PCB). In turn, this PCB screws on to a simple aluminum heatsink which carries the series regulator transistor TR1. The same heatsink is used in the second project to be described, and what is said here about the various mountings will apply equally well to the later design.

The circuit board component layout

and full-size copper foil master pattern is shown in Fig. 4.

When assembling this board the only precautions to be taken are, the usual ones of getting the rectifiers, electrolytics and diodes the right way round. More care is needed for bridge rectifier REC2 than for REC1. Bridge REC1 can only go in one of two ways but REC2 can go in any one of four.

Check very carefully, and take care with the soldering, in particular around the transistor connections. Transistor TR2 must have a corrugated type heatsink pushed on to it, and wirewound resistor R9 should be spaced away from the surface of the board by at least 3mm. There is a short link needed immediately below the position of VR3, don't overlook this or the meter won't work, although everything else will.

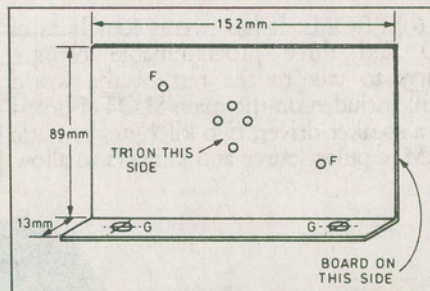

Fig. 5. Heatsink drilling details. Holes at F to match PCB; centre holes TO3 pattern.

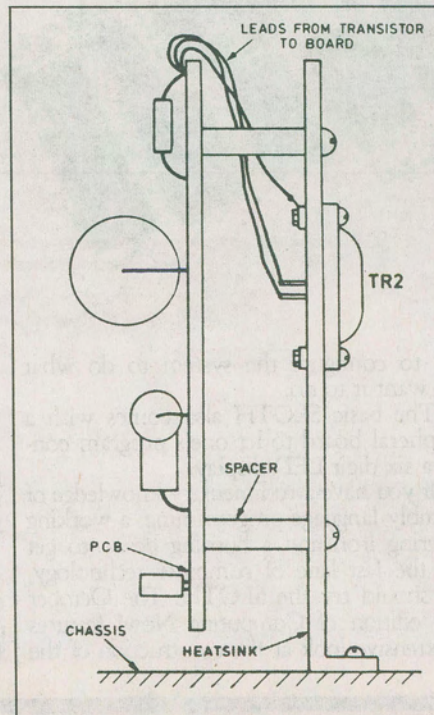

Fig. 6. Circuit board mounted on heat-sink.

Ammeter/Voltmeter

Resistors R13 and R14 need a few words. These convert the basic 50uA meter movement into an ammeter (A) and a voltmeter (V) respectively. Resistor R14 is switched in series with the meter on the *voltage range*; since the meter has to read 25V full scale deflection (FSD) and its own internal resistance is stated to be 1700ohms, we have to

PARTS LIST 25V UNIT

Resistors

| | | |
|------|-------|-------------------|
| R1 | | 100k |
| R2,3 | | 1k0.5W |
| R4,5 | | .47 |
| R6 | | .62k |
| R7 | | .33 |
| R8 | | 100 |
| R9 | | 12.5W wirewound |
| R10 | | .330 |
| R11 | | 1K |
| R12 | | .15 |
| R13 | | 18K 1% (see text) |
| R14 | | .510k 1% |

Potentiometers

| | | |
|-----|-------|------------------------|
| VR1 | | 1k min. preset, vert. |
| VR2 | | 4k7 carbon, lin. |
| VR3 | | 10k min. preset, vert. |

Capacitors

| | | |
|----------|-------|------------------|
| C1 | | 2200u elec. 63V |
| C2 | | .220u elec. 25V |
| C3,C6,C7 | | .22u elec. 25V |
| C4 | | 10n metal film |
| C5 | | .47u elec. 25V |
| C8 | | 10u tantalum 35V |

Semiconductors

| | | |
|---------|-------|----------------------------|
| REC1,2 | | 1.5A or larger bridge |
| D1,2 | | OA91, 1N34, 1N60 germanium |
| D3 | | 10V 400mW Zener |
| TR1 | | 2N3055 NPN power |
| TR2 | | BFY51, 2N2297, 2N2219 |
| TR3,TR4 | | BC182, 2N3904 |

Miscellaneous

| | | |
|-----|-------|-----------------------------------|
| S1 | | 2-pole toggle (or slide) |
| S2 | | centre-off toggle |
| LP1 | | neon pilot with internal resistor |
| T1 | | 28V 1A and 12V 100mA transformers |
| ME1 | | 50uA moving coil meter |

Case, front panel minimum of 229X127mm; 16 gauge aluminum heatsinks corrugated TO heatsink; terminals, 4mm type 1 black, 1 red; 500mA fuse; connecting wire, solder, etc.

Stabilized Power Supplies, Part 3

restrict the current through it to 50uA when 25V is applied to it and R14 in series. By Ohm's law we get: $R14 = 25 / (50 \times 10^{-6}) = 500k$ ohms, less 1700 ohms = 498,300 ohms.

Well, we aren't going to pick that off the shelf, and the best we can do is to use a 510k ohm, 1 percent resistor. This will tend to make the reading slightly on the low side but this is compensated for by the fact that the voltage is actually being measured on the higher potential side of resistor R9 and what appears at the terminals is always slightly less than this.

For the *current reading*, the FSD is 1A. What we are now effectively reading is the voltage drop across R9 interpreted in terms of current. If 1A flowed through R9 it would drop 1V, hence we want the meter to provide FSD when 1V is applied to it and the series resistor R13. Hence $R13 = 1 / (50 \times 10^{-6}) = 20k$ ohm, less 1700 ohm = 18.3k ohm. An 18k ohm, 1 percent resistor will do here.

If, of course, you use any alternative meter, you will need to recalculate these values.

Heatsink

We now have to fit the circuit board to the heatsink which carries the 2N3055 series controller transistor (TR1), and we do this in the same way as we did for last month's project. Bend a piece of 16 gauge aluminum (you can use 14 gauge if you want) to the dimensions shown in Fig 5.

Place the board on the heatsink, away from the "bend" side, and mark through the two mounting holes. The board will be screwed to the aluminum sink at these points using 1/2in. spacers or similar.

Let the bottom edge of the board be a quarter inch or so above the foot of the aluminum. There is nothing critical about the actual positioning.

Spray the heatsink black if possible and mount TR1 at its center, insulating the transistor TO3 case from direct contact with the aluminum with the usual insulating kit. A silicone rubber washer is preferable to mica here, but if you use the latter, give both sides of it a thin smear of heat transfer compound before mounting.

Solder three differently colored flexible leads to the emitter, base and collector (case) of transistor TR1 long enough to reach to the E, B and C solder pads at the top edge of the board after it has been screwed to the heatsink. It is easier if you have soldered Vero pins to these points, and the same, if you wish, to the other output pads.

E&TT December 1989

When the board has been screwed to the heatsink, it should look something like Fig. 6; TR1 leads looping neatly over the top edge of the board and soldered to the appropriate pins. The spacers may be either metal or plastic types, 6BA or 4BA threaded. If you use metal types, ensure that they are not fouling the board wiring tracks. Their length is not critical, but 1/2in. should be considered a minimum.

This completes the board and heatsink assembly.

Boxing Up

We have not specified any particular case for this project (or for the next one come to that) because there is a vast range of suitable cases available at a vast range of prices. Enough to say that the front panel shouldn't measure less than about 229mm (9in.) wide

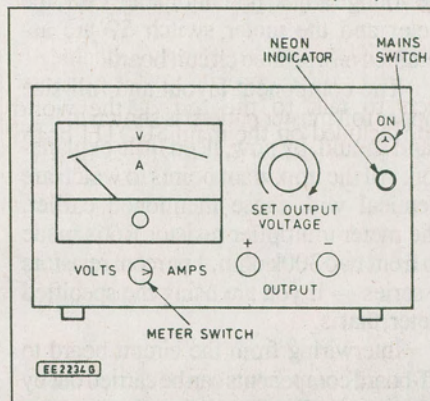

Fig. 7. Suggested front panel layout.

by 127mm (5in.) high, and you will need a depth of 102mm (4in.) minimum.

This panel size will allow room for the specified meter, the meter switch, the voltage adjust potentiometer, the mains switch and indicator neon and the output terminals. The mains lead can come in at the rear where the fuse can also be mounted. A suggested layout is shown in Fig. 7, with the lettering carried out in rub-down letters before the components are fitted.

Inside the box, mount the mains transformer and the heatsink and board panel. The wiring from the board to the external parts is fairly self-explanatory from the circuit diagram: there are two pairs of leads from the XX, YY points to the mains transformer T1 secondary windings (make sure you put them to the right windings) and three leads to the meter switch from points A, M and V.

There are two leads, positive and negative respectively, to the output terminals (note that capacitor C8 is soldered directly across these), and two leads from points P1, P2 to the voltage adjust poten-

tiometer VR2.

Just one point about this last component; the *maximum* output voltage corresponds to the control resistance being all in, i.e. connect P1 to the slider or wiper (W) terminal and P2 to the terminal representing the fully *anticlockwise* position of the slider as viewed from the front. If you do get it wrong, no harm will be done, the output will just decrease instead of increasing as you advance the control clockwise.

Testing

Before switching on and testing the unit, carry out the following adjustments: set preset control VR3 fully anticlockwise i.e. all in circuit. Also preset VR1 to mid-position and the voltage adjust control VR2 fully anticlockwise (minimum output).

Put the meter switch S2 into the VOLTAGE (V) position. Switch on and carefully advance the voltage control on the front panel; if all is well, the voltmeter should read an increasing output.

If this does not happen, it may be that the meter switch has been wired the wrong way round, so switch over to the "amps" side as a quick check. If the meter now reads, reverse the switch wiring.

As the maximum of 25V is approached, adjust the voltage control VR2 in conjunctions with preset VR3 so that, by the time the voltage control has reached its maximum position, the voltmeter just reads 25V FSD (full scale deflection). Preset Vr3 is simply in parallel with VR2 and adjusts the total resistance to give the output level we want.

Now reduce the voltage control to its minimum setting and adjust preset VR1 so that the meter reads exactly zero. Return to maximum voltage and readjust VR3 if necessary to restore the output to 25V. This completes the voltage setting up.

To check on the current side of things and to ensure that the current limiter is working, switch over to CURRENT (A) on the meter switch S2 and short circuit the output. The ammeter should read somewhere about 700mA (0.7A).

This checks the limiting and also the current metering. Remove the short circuit and if by now nothing has started to complain, the power unit is ready for use.

Keep in mind when using this power unit, that once the current limit is reached, the voltage output will stay put and cannot be further increased. For example, suppose you have a load resistance of 30 ohms, then the greatest voltage you can get before 0.7A is reached is 21V. The voltmeter will not, therefore, go past the 21V position.

VARIABLE STABILIZED POWER SUPPLY 0-30V at 1A maximum.

The second of this month's offerings, a 0-30V regulated supply which will provide us with a maximum current of 1A. The complete circuit diagram for the 0-30V Stabilized Power Supply is shown in Fig. 8.

In most respects this circuit is similar to the one we have already discussed, as a glance at Fig. 8 will show. A mains transformer T1 with twin secondary windings provides a positive and a negative supply by way of the two bridge rectifiers and appropriate smoothing and there is the familiar series controller transistor TR1 with its driver TR2.

The error detector this time consists of a "long tailed pair", transistors TR5 and TR6 in a differential circuit. This gives an advantage over the previous supply in that stabilization against temperature changes is provided by this form of circuit. Only the difference between the two bases is amplified and temperature variations will tend to move both bases in the same direction.

The output from the collector of TR5 goes to the error amplifier TR4 which in turn drives the base of TR2. This, along with series controller TR1, forms a Darlington pair which controls the effective resistance of TR1 and so regulates the output against unwanted variations in the manner already described.

The current limiter this time is TR3 which senses the voltage developed across resistor R5, a part of which is tapped off by way of preset VR2. In this way the maximum output current can be set to 1A, or anything smaller if you so desire. The output is smoothed by capacitor C3 and protected against reverse input transients by diode D5.

Construction

The 0-30V unit is built in exactly the same way as the previous project. All components except the mains transformer T1, the voltage adjust potentiometer VR3, the meter and the meter switch S2 are assembled on a printed circuit board.

The component layout and full-size copper foil master pattern is shown in Fig. 9 and should, by now, need little explanation. All the important points to watch are identical with those mentioned earlier. The meter multiplier resistor R6 is made up from two 300k ohm, 1 percent resistors in series — if you are using the specified meter, that is.

Interwiring from the circuit board to off-board components can be carried out by referring to Fig. 9 and the photographs. Two pairs of leads from the points Z-Z and X-X go to the mains transformer secondary windings of 32V and 15V respectively.

Four leads from points A, B, C and D on the board go to the meter switch S2, which this time is a double-pole change-over miniature toggle (or you may use a slide type if you wish); two leads are taken to the voltage adjust potentiometer VR3, one of which is common to the output positive lead; and the positive and negative outputs themselves. Use at least 16/0.2mm flexible wire for the transformer connections and the output leads.

After completing the board and drilling the two fixing holes marked F, mark these through on to the heatsink, and drill these and the TO3 case fitting holes for TR1 in the same way as was described previously. Transistor TR1 should now be fitted to the heatsink, and the board screwed in place, using 1/2 in. spacers; refer back to Fig. 6. Three colored leads from points C, B and E should be soldered to TR1 pins.

The assembly, together with the various other components can then be fitted into a suitable case and the panel layout can again follow that suggested in Fig. 7. The meter this time, of course, is calibrated 0-50V, 0-1A (see "Meter Scale" section).

Testing

Set preset VR1 and rotary control VR3 fully anticlockwise (all in, presets VR2 and VR4

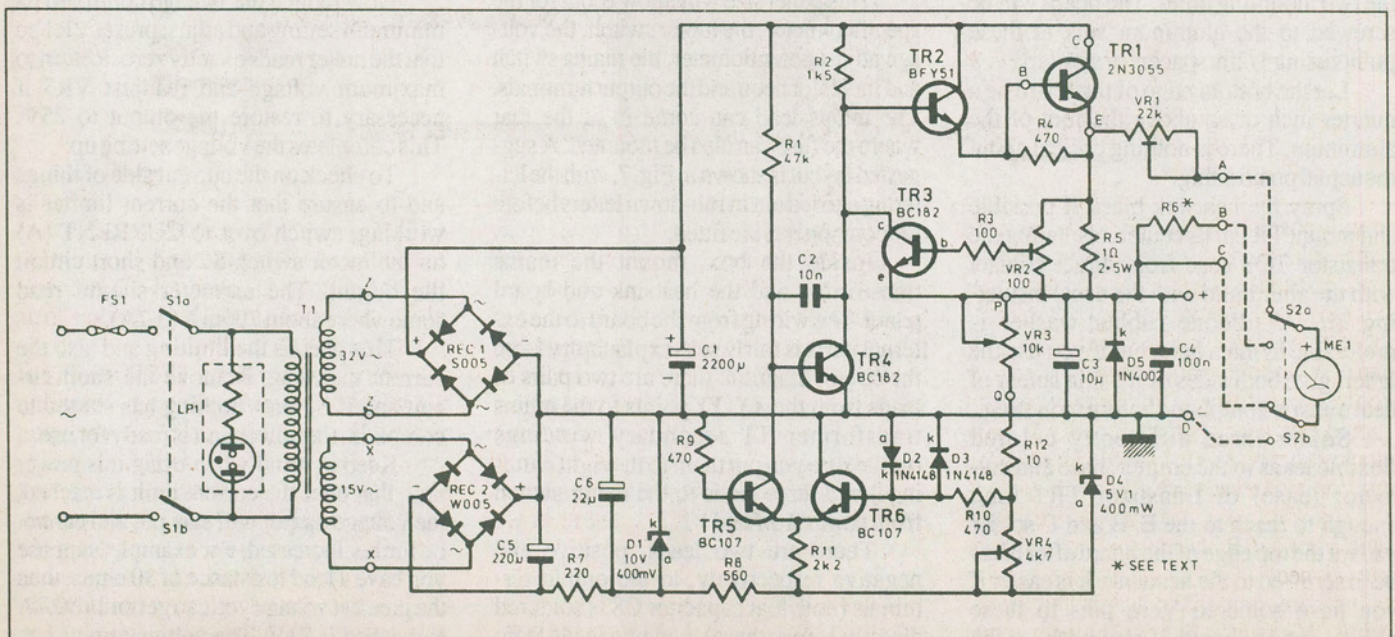
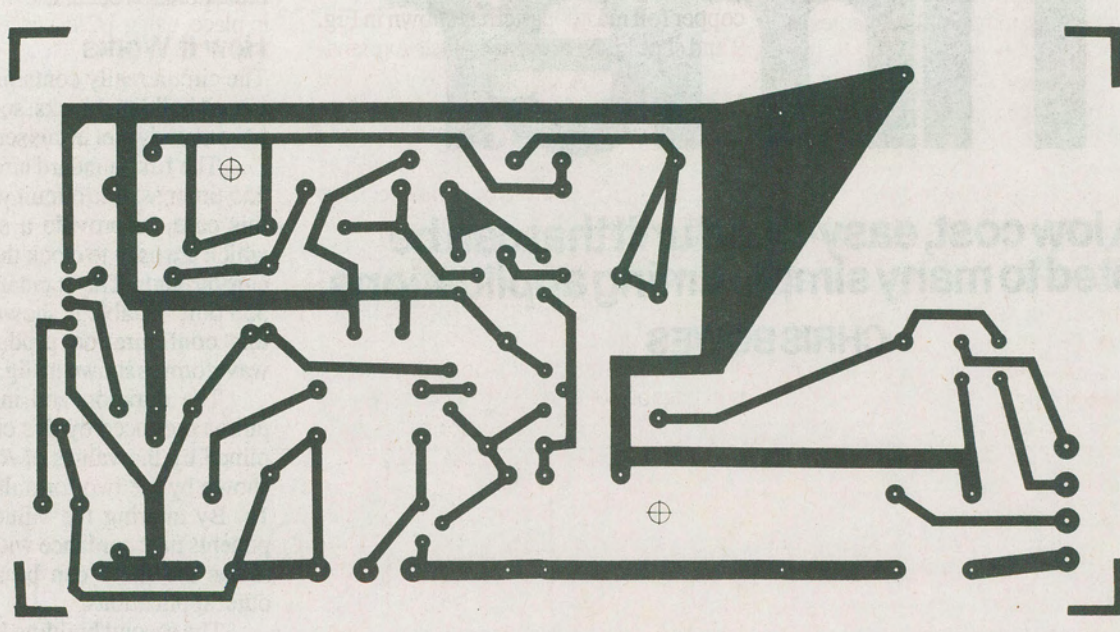
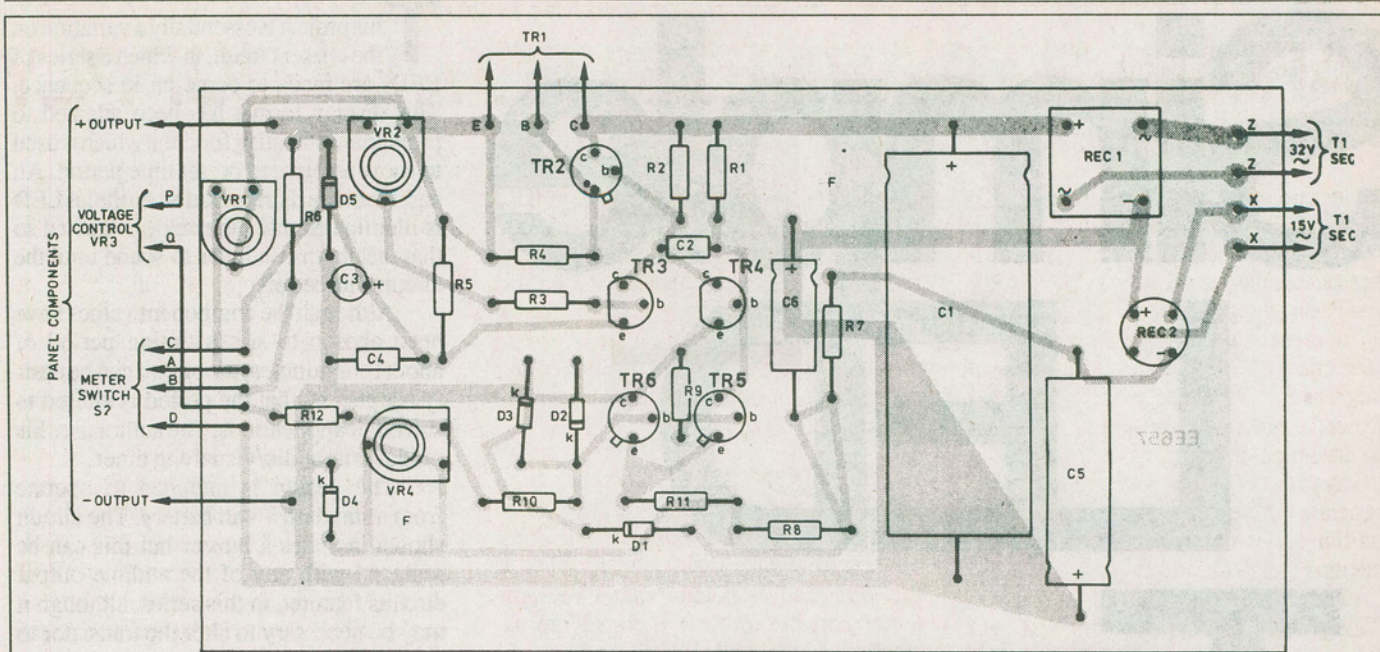

Fig. 8. Circuit diagram for the 0-30V 1A supply.



to mid-position. Note that VR3, the front panel voltage control, is wired so that all the track resistance is in circuit with the wiper fully anticlockwise viewed from the front.

Set the meter switch S2 to VOLTAGE and after switching on, advance the voltage control carefully. The voltage output should rise and when the control is fully clockwise, preset VR4 should be adjusted until the meter reads exactly 30V FSD

To calibrate the current reading, switch to CURRENT on the meter switch and connect a load resistor in series with an ammeter across the output terminals. Adjust VR1 until the panel meter reads identically to the external ammeter.

If you don't have another ammeter as a checker, connect a known resistance (say 10 ohm, 3W) across the output terminals and advance the voltage control to provide, say, 5V output (as seen on the voltmeter). The current will now be 0.5A, so switch over to CURRENT and adjust VR1 accordingly. If you don't fancy all this, just replace VR1 with an 18k ohm, 1 percent resistor (0.5W) and the current reading will be sufficiently accurate not to lose any sleep over.

Current Limit

mit of 1A now has to be set. Turn the voltage control to minimum, switch over to

CURRENT, and put a short-circuit across the output. Advance the voltage control so that the meter goes over to FSD or thereabouts, then adjust VR2 until the current is just below the 1A reading.

What you aim for is a FSD reading of 1A when the output is shorted — nothing more. If the meter cracks over, you haven't adjusted VR2 properly.

You can, if you wish, set the current limit to any value less than 1A; simply adjust VR2 to give you that limit when the output is short circuited. Like the previous design, the voltage will then not increase above the point at which the current has reached its limiting value.

Continued on page 54

Power Supplies

Continued from page 15

PARTS LIST 30V UNIT

Resistors

| | |
|---------------|--------------------|
| R1 | 47k |
| R2 | 1.5k 0.5W |
| R3 | 100 |
| R4,9,10 | 470 |
| R5 | 102.5W wirewound |
| R6 | 300k 1% (see text) |
| R7 | 220 |
| R8 | 560 |
| R11 | 2k2 |
| R12 | 10 |

All 0.25W carbon film, except where stated.

Potentiometers

| | |
|-----------|--------------------|
| VR1 | 22k preset, horiz. |
| VR2 | 100 preset, horiz. |
| VR4 | 4k7 preset, horiz. |
| VR3 | 10k carbon, lin. |

Capacitors

| | |
|----------|-----------------------|
| C1 | 2200u axial elec. 63V |
| C2 | 10n metal film |
| C3 | 10u tantalum 35V |
| C4 | 100n metal film |
| C5 | 220u axial elec. 25V |
| C6 | 22u axial elec. 25V |

Semiconductors

| | |
|-------------|---------------------------|
| REC1 | 2A bridge rectifier |
| REC2 | 1.5A bridge rectifier |
| D1 | 10V 400mW Zener |
| D2,3 | 1N4148 signal diode |
| D4 | 5.1V 400mW Zener |
| D5 | 1N4002 1A 100V diode |
| TR1 | 2N3055 NPN power |
| TR2 | BFY51, 2N2297, 2N2219 NPN |
| TR3,4 | BC182, 2N3904 NPN |
| TR5,6 | BC107, 2N3904 NPN |

Miscellaneous

| | |
|-----------|---------------------------------|
| S1 | 2-pole toggle (or slide) |
| S2 | centre-off miniature toggle |
| T1 | transformers, 32V and 15V secs. |
| ME1 | 50uA moving coil meter |

Case, 16 ga. aluminum heatsink; corrugated TO heatsink; terminals, 4mm type 1 black, 1 red; 500mA fuse; connecting wire, solder, etc.