

Designing With Switching Regulators

IC switching regulators simplify power supply design, increase efficiency and reduce size

By Anthony J. Caristi

Whatever your interest in electronics, by now you've probably noticed that a relatively new type of power supply is appearing in every type of sophisticated electronic equipment from color TV receivers to microcomputers. Called the "switching regulated supply," it has just about made obsolete the bulky and expensive 60-Hz power transformer that has heretofore predominated in power supply designs. Not only does the switching regulated power supply satisfy the compact design demands required in miniaturized products, it offers better efficiency and costs less to make compared to traditional designs.

On first encounter, a switching regulated power supply might appear to be extremely complicated. Earliest designs, built around discrete components, certainly were very complicated. However, development of specialized switching regulator integrated circuits have made switching supply design quite straightforward nowadays. One such IC is the Raytheon RC4192, which we'll be discussing at length in this article. Once you understand how this chip works, switching regulated power supplies should hold no mystery.

Raytheon's RC4192 is an excellent chip to use to illustrate the switching regulator circuit because of its sim-

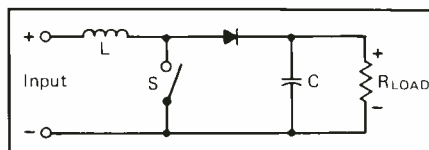

Fig. 1. In step-up mode, voltage at output is greater than that at input.

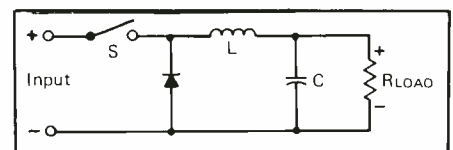

Fig. 2. In step-down mode, output voltage is less than input voltage.

plicity and the fact that it works well in battery-powered equipment. Since it operates with an input of as little as 2.4 volts, the RC4192 is very practical to use in electronic equipment that requires 9 volts or more of battery power, such as small AM and FM radios. Using this chip in its step-up mode makes it possible to operate the equipment from a 3.6-volt NiCd rechargeable battery or even four solar cells connected in series.

Switching Regulation Defined

Basically, a switching regulator controls the output voltage of a dc supply by toggling a switch, usually a transistor, on and off in response to a change in input voltage or the demand of the load on the supply. Connected to the output of the supply, a sensing circuit monitors the voltage and varies the switching duty cycle to deliver more or less energy to maintain a constant output voltage.

Since a transistor has practically no dissipation when fully on and zero dissipation when off, there's much less power loss in this type of circuit

than there is in a linear regulated supply that uses dissipative elements to control output voltage. This is the key to high efficiency. Since the frequency of the switching supply is usually above the audible range, ac line-powered regulators can be designed with an isolation transformer that is considerably smaller than the equivalent old fashioned 60-Hertz power transformer.

There are two basic categories of switching regulators: step-up and step-down, which produce regulated output voltages that are higher or lower, respectively, than the input voltage. Simplified diagrams of both types of regulators are shown in Figs. 1 and 2. The switch shown in both is usually a transistor that is turned on and off at a rate of 20 kHz or greater, with varying duty cycle. In general, if the regulated output voltage of the supply should tend to decrease, due to an increase in load or a drop in input voltage, the duty cycle of the transistor will automatically change to increase the amount of current delivered to the output circuit of the supply. Should the output voltage of

Applying Raytheon's PC4192 integrated circuit

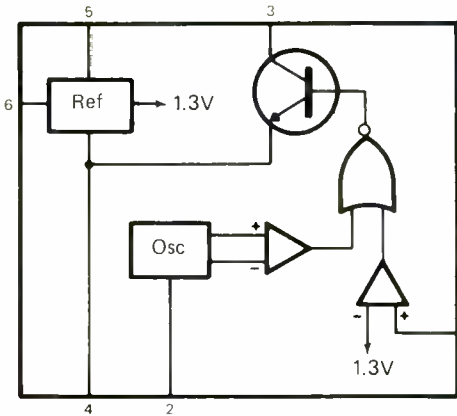

Fig. 3. This is the simplified block diagram of the RC4192 regulator chip.

the supply tend to increase for any reason, the transistor's duty cycle would react in the opposite manner.

Theory Of Operation

In the step-up mode of Fig. 1, full input voltage appears across the inductor when the switch is closed, charging the inductor with a current that rises linearly with time. During the time the switch is closed, the diode is back-biased and current to the load is supplied by the charge on the capacitor. When the switch opens, the charged inductor develops a voltage, from the collapsing magnetic field, that aids the input voltage. This provides current to feed the load while replenishing the charge on the capacitor. When the switch opens again, the cycle is repeated. A sensing circuit (not shown in Fig. 1) monitors the output voltage of the supply and controls the duty cycle of the switch so that average current through the inductor is equal to load current.

The step-down circuit in Fig. 2 operates in a slightly different manner. In this mode, the switch is connected in series with the supply voltage source. When the switch is closed, the voltage across the inductor is equal to the input voltage minus the output voltage ($V_{in} - V_{out}$), and the inductor is charged with a current that increases linearly with time. As induc-

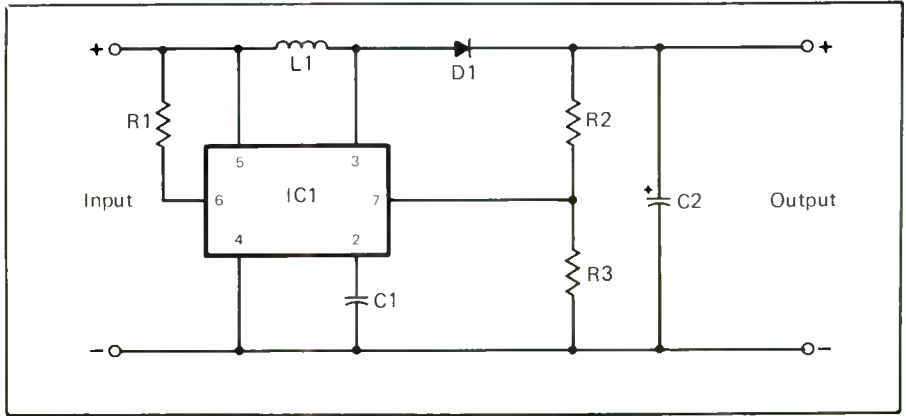

Fig. 4. Using the RC4192 regulator in the step-up mode, the circuit is relatively simple and straightforward, as shown in this schematic representation.

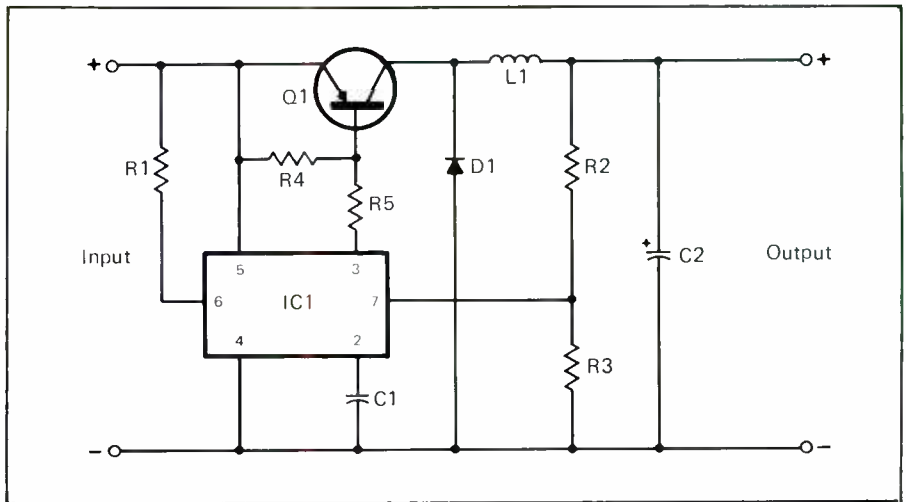

Fig. 5. In the step-down mode, external transistor Q1 is required to perform the switching function because of design restraints of the RC4192 regulator.

tor current builds up, the capacitor feeds current to the load. When the current through the inductor exceeds load current, the capacitor is charged. When the switch opens, the diode is forward-biased by the voltage across the inductor and current provided by the charged inductor continues to feed the capacitor and load. The cycle is repeated when the switch closes again. As in the step-up configuration, the average current through the inductor is equal to the load current.

Figure 3 is a simplified block diagram of the RC4192 regulator. It contains a reference circuit that de-

velops a stable output of 1.3 volts against which the output of the regulated supply is compared. Bias current (about 5 microamperes) for the reference circuit is set by an external resistor connected to pin 6 of the chip. The reference voltage is fed to one input of a comparator, the divided-down output of the regulator to the other input. Thus, when the voltage at pin 7 of the chip exceeds 1.3 volts, the comparator output goes high and cuts off the switching transistor through the NOR gate. An internal oscillator, whose frequency is determined by an external capacitor connected to pin 2, provides the

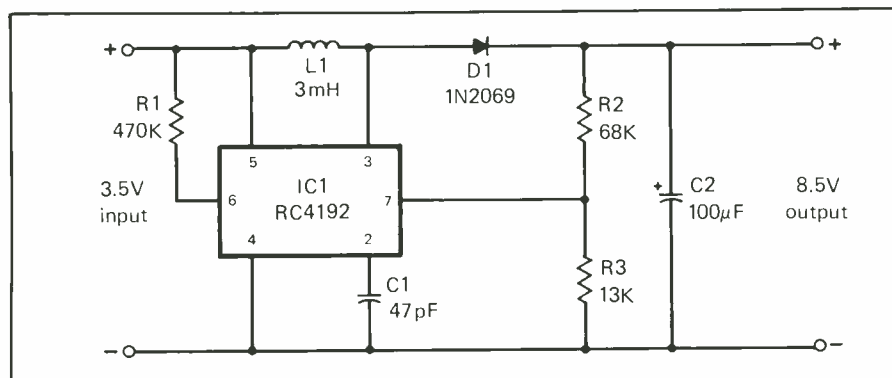

Fig. 6. Shown here is the complete schematic diagram of the step-up switching regulator built around the RC4192 and designed to deliver an 8.5-volt output.

switching signal through the NOR gate. The chip's internal transistor is the switch illustrated in Fig. 1. It's capable of switching currents as great as 150 milliamperes.

Although the step-up and step-down configurations of the switching regulator are different, it's possible to use the same IC to accomplish both tasks. Illustrated in Figs. 4 and 5 are the complete schematic diagrams of the two types of regulator circuits.

In the step-down circuit, an additional transistor is required to perform the switching function, since the RC4192's internal switching transistor is connected to circuit common and cannot be placed in series with the input voltage.

Design Equations

Design of a step-up or -down switching regulator has been simplified by

the Design Equation Table, which enables you to calculate the values of R , L and C for each circuit. The only things you must provide to solve the equations are input voltage, output voltage, and load current. The regulator's operating frequency is determined by the value of $C1$. This frequency is about 45 kHz for a $C1$ value of 47 picofarads. The calculated value of $C2$, using the table, will provide a ripple output of about 0.1 volt rms or 0.3 volt peak-to-peak.

To illustrate an application that replaces a 9-volt transistor battery with a 3.6-volt NiCd battery as the power source that feeds a small AM/FM radio, it's assumed that load current (I_L) will be 10 milliamperes, input voltage (V_{in}) will be 3.5 volts, and that the switching regulator will provide an output (V_{out}) of 8.5 volts. Plugging these figures into the design equations for the step-up regulator, we obtain: $R1 = 460,000$ ohms (460k); $R2 = 72,000$ ohms (72k); $L1 = 0.0033$ H (3.3 mH); and $C1 = 8.82$ microfarads (8.82 μ F).

Figure 6 illustrates the overall schematic diagram of this step-up switching regulator circuit in which the closest standard values for the calculated component values are shown.

Regulator Design Equations

Component	Step-Up (Fig. 4)	Step-Down (Fig. 5)
R1	$\frac{V_{in} - 1.2}{5 \times 10^{-6}}$ (ohms)	$\frac{V_{in} - 1.2}{5 \times 10^{-6}}$ (ohms)
R2	$\frac{V_{out} - 1.3}{0.0001}$ (ohms)	$\frac{V_{out} - 1.3}{0.0001}$ (ohms)
R4	—	$\frac{35}{I_L}$ (ohms)
R5	—	$\frac{0.3V_{out}}{45,000I_L}$ (ohms)
L1	$\frac{0.3V_{in}(V_{out} - V_{in})}{45,000I_L(V_{in})}$ (Henrys)	$\frac{0.3V_{out}}{45,000I_L}$ (ohms)
C2	$\frac{2V_{out} - V_{in}}{0.018V_{out}}$ (microfarads)	$\frac{I_L}{0.018}$ (microfarads)
R3	13,000 ohms	13,000 ohms
C1	47 pF	47 pF

In Closing

When using switching regulator circuits, a word of caution is in order. Keep in mind that switching regulators operate at high audio frequencies and are rich in harmonics, the latter the result of sharp risetimes of the waveforms. If you use a switching regulator to power a radio receiver, be sure to use full shielding and filtering. If you don't, you'll find that the harmonics will cause considerable r-f interference with the signals being received. This interference is one of the penalties you must pay when using switching regulators. But it's little enough, considering the advantages to be gained.

ME