

# GUARD PRECIOUS COMPONENTS from Overload Damage

*A single IC provides extra protection for a variety of electronic circuit devices*

*By Harold Wright*

**V**OLTAGE regulators such as those used in many electronic circuits require a much higher source voltage than what they deliver as a regulated output. If such a regulator fails, it is quite possible that its output will increase to a disastrously high voltage for the components it is supplying. For in-



...OVERVOLTAGE

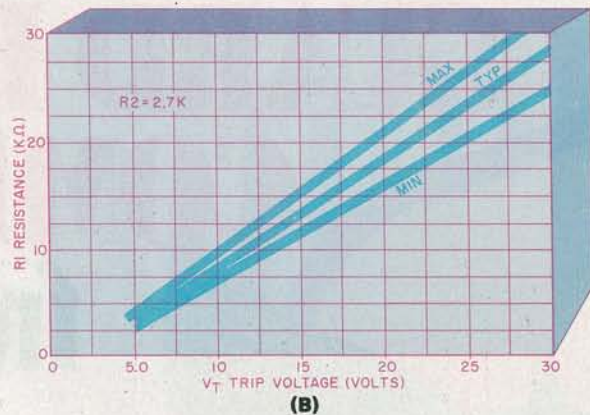
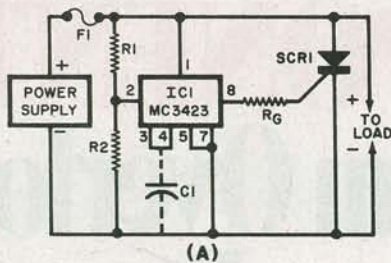

Fig. 1. The basic overvoltage circuit (A) using an MC3423 for power supplies between 4.5 and 36 V. The curves at (B) show how  $R_1$  can be used to adjust the trip point.

stance, such components as the Intersil 7107 V/F converter is rated to operate normally at  $\pm 5$  V, with  $\pm 6$  V being an absolute maximum. Thus, if the power supply fails and the voltage rises above the maximum, this expensive chip will be destroyed. Consequently, it is advisable to check the spec sheets of the ICs you are using. Then check your power supply; and, if necessary, provide some means of overvoltage protection.

Very few experimenter circuits (and not much commercial equipment) have overvoltage protection; and except for having fuses, not many automotive electronic items are protected in this manner. The overvoltage protection schemes shown in this article can be applied to existing (or planned) circuits and will work with both line-powered and mobile equipment, including those operating from the vehicle battery/alternator system.

The circuits to be discussed are

designed around the MC3423 Overvoltage Protector (OVP). The basic circuit, used for power supplies between 4.5 and 36 V, is shown in Fig. 1A. When  $IC_1$  is triggered through pin 2, pin 8 goes high. This triggers  $SCR_1$  through resistor  $R_g$ . The SCR then acts as a short circuit across the power supply, causing the fuse to blow and remove power from the load. This approach is called a "crowbar."

The trigger level is determined by the ratio of  $R_1$  to  $R_2$ . As shown in Fig. 1B,  $R_2$  is fixed at 2.7 kilohms and the value of  $R_1$  can be scaled from the graph. To permit precise adjustment of the trip point,  $R_1$  can be divided into two components—one a fixed resistor and the other a multi-turn trimmer potentiometer. The total value of the fixed resistor and half the value of the trimmer potentiometer add up to the value of  $R_1$  as determined by Fig. 1B. Thus, the trimmer potentiometer can be set slightly above or

below the desired trip point. To protect a 5-V TTL supply, for example, make the variable trimmer 1 kilohm and the fixed portion 3.3 kilohms. Set the trip point to 6 V, a safe value for TTL.

No type number is given for  $SCR_1$ , since it depends on the value of the protective fuse,  $F_1$ . Select an SCR whose turn-on current exceeds the value of the fuse so that, when the SCR is turned on, it will take sufficient current to blow  $F_1$ . Gate-current limiting resistor,  $R_g$ , is selected by the graph in Fig. 2A. For voltages below 11 V, omit  $R_g$ .

To avoid tripping the protector when line transients occur, pins 3 and 4 (connected together as shown in Fig. 1A) can be connected to the negative (common) line through a bypass capacitor ( $C_1$ ). This sets the minimum duration of overvoltage allowed before  $IC_1$  triggers. When the voltage rises above the trip point,  $C_1$  starts to charge. If the voltage is transient and is over be-

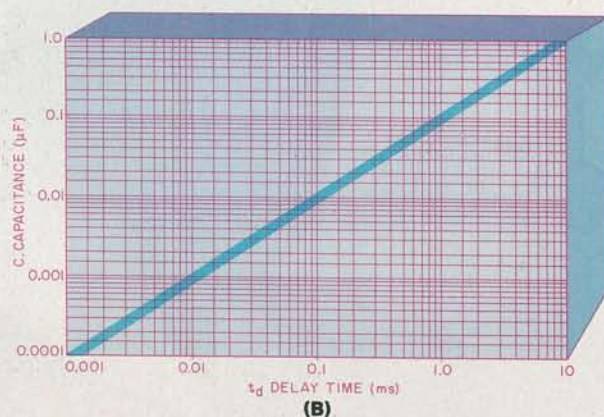
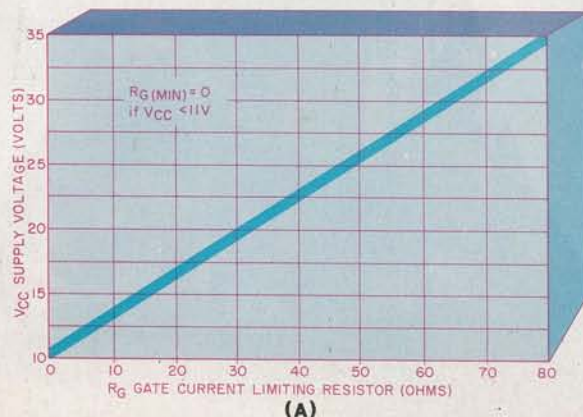

Fig. 2. The curve at (A) is used to select a value of  $R_g$  for the SCR and (B) is to choose a bypass capacitor for  $IC_1$ .

## ...OVERVOLTAGE

fore the capacitor charges, *IC1* does not trip. Figure 2B shows the relationship between the value of *C1* and the duration of the delay. For example, with a value of 0.01  $\mu\text{F}$ , the delay is 0.1 millisecond. The partial circuit shown in Fig. 3 is a modification that does not blow fuses. Instead, when turned on, the SCR operates relay *K1* to remove power from the load. Diode *D1* protects the SCR from the back emf generated when the coil inductance is removed from the circuit. Capacitor *C2* reduces sparking at the relay contacts when they open, thus improving relay life.

If a two-pole relay is used, the second pole can provide power to a LED or operate a warning device such as a Sonalert. Resistor *R3* is selected for safe LED current.

To protect a negative power supply, use the circuit shown in Fig. 4., an inverted version of Fig. 1A.

Both sides of a dual supply can be protected by the circuit shown in Fig. 5. In a  $\pm 5\text{-V}$  supply, the total voltage across the two outputs is 10 V. Any increase in voltage in either side of the supply (such as the negative voltage becoming more negative or the positive more positive) will increase the total voltage across *R1/R2* and *IC1*. If *IC1* is set to trip at 11 V, then a negative increase to  $-6\text{ V}$  or a positive increase to  $+6\text{ V}$  will cause triggering. When *IC1* triggers, pin 8 goes high relative to both ground (common) and the negative side of the supply. It will reach a voltage slightly less than half the tripping level when referenced to the common. In a dual  $\pm 5\text{-V}$  supply set to trip at 11 volts, pin 8 would reach a high of about 5.5 V to ground. This is enough to trip the SCR. The voltage across the SCR load can be used to operate a relay to shut down the power.

If an inhibiting high signal is needed from a negative output supply, use the circuit shown in Fig. 6.

Note that an opto-coupler is used as the load instead of the SCR. Before *IC1* triggers, pin 8 is negative with respect to ground and when *IC1* triggers, pin 8 drops to ground. When this occurs, the LED in the opto-coupler is properly biased and turns on. Resistor *R3* limits the LED current to the required value. The other side of the opto-coupler is connected between an external positive supply and ground through *R4*. When the LED glows, a high will be present across *R4* and it can be used for inhibiting purposes.

**Mobile Use.** Much expensive electronic equipment is used in vehicles and boats. These also require protection. One of the problems can be

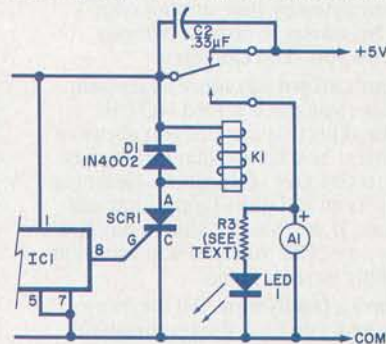

Fig. 3. Circuit to remove power from the load and sound an alarm.

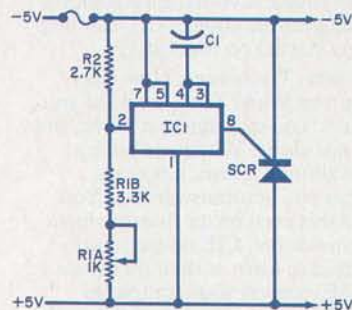

Fig. 4. Use this circuit instead of Fig. 1A for a negative supply.

a type of overvoltage peculiar to battery/alternator/regulator systems. Alternator regulators can fail in such a way that the alternator is allowed to run out of control or wide open. In this situation, as much as 20 to 22 V can be present on the 12-V system of the vehicle.

In the circuit shown in Fig. 7, the trip point can be set to about 15 V. In this case the load is fed from the relay contacts; and, if an overvoltage occurs, the relay operates to remove the damaging voltage from

# The Safe Video Head Cleaner is Dry.



Yes, dry!

The Discwasher® Video Head Cleaner is the only truly nonabrasive dry head cleaner on the market today.

Its superior cleaning action is the result of its textured fabric matrix, not the result of abrasive properties (like those often utilized in aluminum oxide cleaners). This exclusive matrix safely cleans not only the video heads, but the audio and sync heads as well.

The Discwasher Video Head Cleaner is less abrasive than both the video head and video drum. In fact, it's even less abrasive than video tapes themselves. And best of all...it works. Easily, safely, and quickly.

The graph below represents approximate hardness ratings of individual VCR components and various tapes and cleaners using the Temper scale, developed by industry to measure materials. A diamond, one of the hardest materials known, rates T-10.

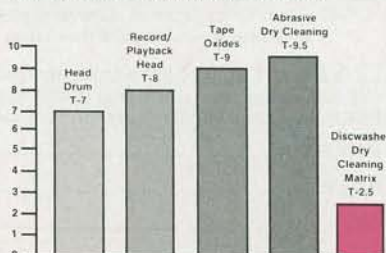

## discwasher

1407 N. PROVIDENCE RD., P.O. BOX 6021, DEPT. CE, COLUMBIA, MO 65205 USA  
A DIVISION OF JENSEN an ESMARK Company

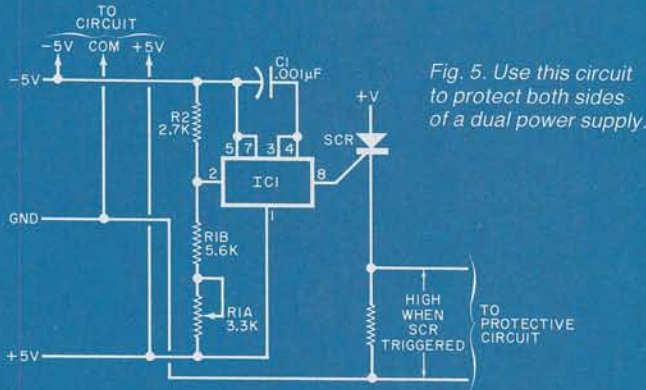

Fig. 5. Use this circuit to protect both sides of a dual power supply.

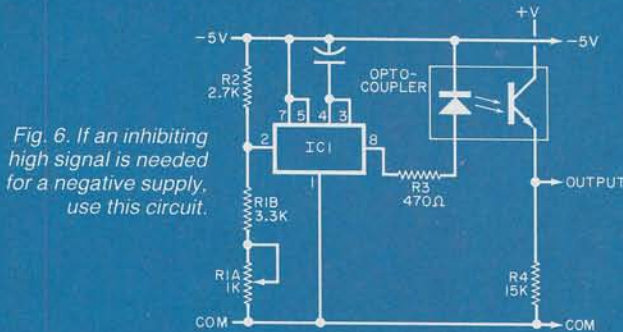

Fig. 6. If an inhibiting high signal is needed for a negative supply, use this circuit.

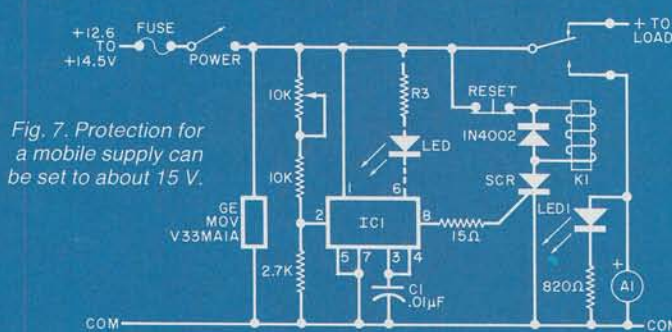

Fig. 7. Protection for a mobile supply can be set to about 15 V.

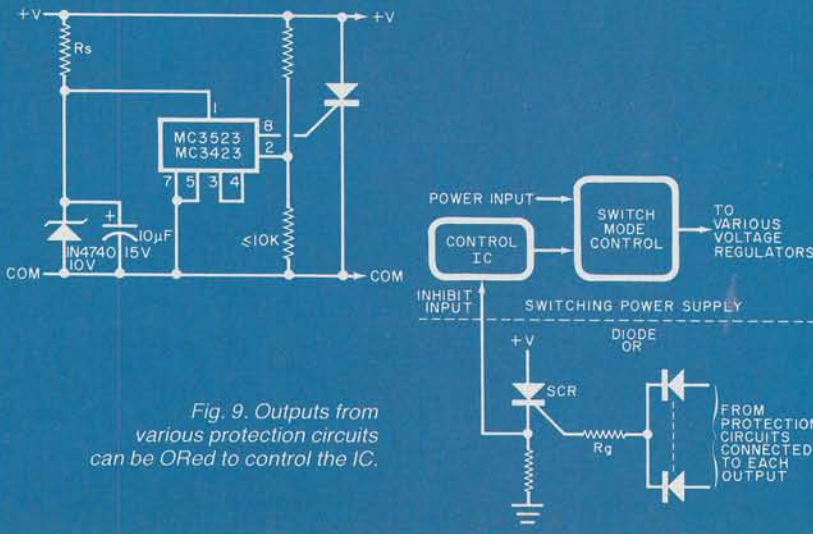

Fig. 9. Outputs from various protection circuits can be ORed to control the IC.

the load and activate the alarm.

Since mobile systems tend to have more voltage transients than power-line systems, if a number of false alarms are encountered (system shutting down often), the value of *C1* must be increased. However, excessive tripping may indicate that the vehicle electrical system needs cleaning up. Sparking brushes in alternators, windshield wipers, bilge pumps, blower motors, etc. can be the main culprits.

The optional GE MOV varistor protection transient protector for 15 V will catch most transients, while the MC3423 circuit will catch the rest. The normally closed RESET switch is used to reset the SCR after trip (if the fuse does not blow) and should not be held open for any reason, otherwise the damaging voltage can get to the load.

If you want to have only a transient monitor, remove the circuit coming from pin 8. Internally, *ICI* has an uncommitted npn transistor collector tied to pin 6; and, when *ICI* trips, this transistor turns on. You can connect a LED and current-limiting resistor (shown dotted in Fig. 7) to this pin.

For voltages higher than 36 V, Motorola recommends the following SCRs: for 50 V—2N6504; 100 V—2N6505; 200 V—2N6506; 400 V—2N6507; 600 V—2N6508; and 800 V—2N6509. Either an MC3523 or MC3423 can be used for *ICI*, if it is powered from a zener-regulated 10-V source (Fig. 8).

**Switching Supplies.** The protection circuit can also be used with pulse-width modulated switching power supplies. Most of these are provided with an inhibit input that shuts the supply down when a high is applied.

A protection circuit, such as those shown here, can be connected to each dc output of a switching supply. Each output from the various protection circuits can be applied to a diode-OR circuit, such as that shown in Fig. 9, with the OR driving an SCR gate. When the SCR triggers on, the voltage developed across its load resistor is applied to the inhibit input of the control chip of the switching supply, thus shutting it down. ♦