

BUILD THE "SUPER MARKER"

Inexpensive marker generator with selectable 100-, 50-, 20-, or 10-kHz output allows precise tuning of shortwave receivers.

A STABLE source of marker frequencies is one accessory that belongs in every shortwave listener's shack. Many receivers contain built-in 100-kHz calibrators, but for exact tuning, smaller marker increments are required. The Shortwave Super Marker described in this article is an inexpensive, easily built frequency standard that will provide precise markers at selectable increments of 100, 50, 20, or 10 kHz. Built around a quartz crystal, two npn transistors, and a CMOS divider IC, the project can be assembled in two hours or less. Total parts cost is about \$15.

About the Circuit. Transistor *Q1*, the quartz *XTAL* and their associated components comprise a stable 100-kHz oscillator. Trimmer capacitor *C1* allows the

user to zero-beat the oscillator against a frequency source of known accuracy such as radio station WWV or WWVH. The 100-kHz output of the oscillator is applied to pin 14 of *IC1*, the CLOCK input of a CD4017 CMOS decade counter/divider with ten decimal outputs.

Depending on the position of *S1*, the RESET terminal of *IC1* is either grounded or connected to one of three decoded decimal outputs. When the RESET terminal (pin 15) is grounded, *IC1* functions as a ÷10 counter and a 10-kHz pulse train appears at pin 2. If pin 15 is connected to pin 1, the counter resets itself every 5 clock pulses and a 20-kHz pulse train is developed. Connecting pin 15 to pin 4 causes the counter to reset after every second clock pulse. The counter then acts as a ÷2 stage and produces a

50-kHz output. When pin 15 is connected to pin 2, the counter resets itself on the negative edge of each clock pulse, acting like a ÷1 stage and producing a 100-kHz pulse train at pin 2.

Transistor *Q2* and its associated components comprise an amplifier which is driven by the programmable counter's output pulses. This stage amplifies the harmonics of the fundamental pulse train frequency so that they are of usable strength up to 30 MHz. Accordingly, if *S1* is placed in the 100-kHz position, the user will hear marker signals every 100 kHz as he tunes across the dial of his general-coverage receiver. Successively higher-order harmonics will be increasingly weaker, but usable markers will be found to at least 30 MHz, the upper limit of most receivers.

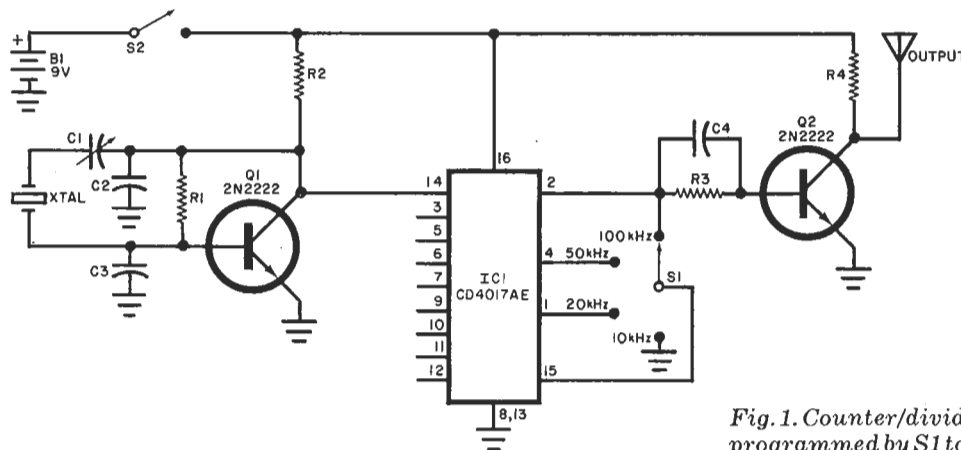

Fig. 1. Counter/divider IC1 can be programmed by S1 to provide marker frequencies at selected intervals.

PARTS LIST

B1—9-volt transistor battery
C1—7-to-45-pF trimmer
C2, C3—0.001- μ F disc ceramic
C4—50-pF disc ceramic
IC1—CD4017AE CMOS decade counter/
divider with decoded decimal outputs
Q1, Q2—2N2222 npn silicon transistor

The following are 1/4-watt, 10% tolerance fixed carbon-composition resistors:

R1—150,000 ohms
R2, R3—8200 ohms
R4—5600 ohms
S1—1-pole, 4-position nonshorting rotary switch

S2—Spst toggle switch
XTAL—100-kHz quartz crystal
Misc.—Molex Soldercons or IC socket, printed circuit or perforated board, suitable enclosure, battery holder and clip, hookup wire, machine hardware, circuit board standoffs, solder, etc.

Construction. Parts placement is not critical, so printed circuit or point-to-point perforated board techniques can be employed. The use of an IC socket or Molex Soldercons is recommended for mounting the CMOS device. Carefully observe the standard precautions when handling the CMOS device and pay attention to the pin basing of both the IC and transistors. Any four-position rotary switch can be used for *S1*. If you already have a switch with more than four positions, you can use it in the circuit if the extra positions are grounded.

The output antenna shown in the schematic is simply a length of hookup wire that can either be wrapped around the antenna lead-in (if a single wire feed is used) or physically placed close to the r-f input stage. No direct connection between the Super Marker and receiver is required. The project can be housed in any small enclosure or even mounted inside the receiver if space is available. For simplicity, a 9-volt battery is used as the power source. However, a small well-filtered, line-operated supply can be used instead. A third alternative is to tap the receiver's dc supply or, if the project is to be used with an older tube-type receiver, the ac filament voltage can be rectified, filtered and zener regulated.

Calibration. Tune your receiver to WWV or WWVH at 2.5, 5, 10 or 15 MHz. With the Super Marker's antenna coupled to the input of the receiver and switch *S1* in the 100-kHz position, close power switch *S2*. You should hear both the NBS transmission and an audio tone whose pitch will vary as trimmer capacitor *C1* is adjusted. If you don't hear the audio tone, increase the coupling between the Super Marker's antenna and the receiver input.

Carefully adjust *C1* so that the audio tone decreases in pitch and becomes a "flutter" on the NBS transmission. Ideally, *C1* should be set for a zero beat. That is, the marker and r-f carrier are at exactly the same frequency and no beat note is created. Adjust the trimmer capacitor during the portions of the WWV or WWVH transmission when only second ticks and no continuous audio tone superimposed on the ticks are heard. Otherwise, you may zero beat the marker to the modulating tone instead of the r-f carrier.

A nonmetallic screwdriver, alignment, or neutralization tool should be used when making these adjustments. Even so, you might find that the presence of the tool and/or your hand will affect the

oscillator's frequency. Withdraw the tool and your hand between adjustments to ensure that a true zero beat has been obtained.

It's a good idea to drill a hole in the project enclosure so that *C1* can be adjusted after the enclosure has been "buttoned up." This will minimize the detuning effects of hand, tool and even enclosure capacitance. Also, this hole will enable you to periodically touch up the adjustment of *C1* without having to remove the top of the enclosure.

Use. Turn on the receiver's bfo and tune up the band until another marker is encountered. (Don't confuse a broadcaster's carrier with a marker. Open and close power switch *S2*. The marker tone should appear and disappear as power is applied to and removed from the circuit.) Note the frequency indicated on the dial and tune back to WWV or WWVH. Next, place *S1* in the 50-kHz position and tune up the band until you encounter a marker. The dial frequency should be midway between that of WWV or WWVH and the previously noted marker frequency. With *S1* in the 20-kHz position, you should detect five markers—one at the NBS station's frequency, one at the previously noted marker frequency, and three spaced evenly between the two. In the 10-kHz mode, the Super Marker should generate ten evenly spaced markers across this 100-kHz band segment.

The Super Marker will allow you to tune your receiver very precisely even if its tuning mechanism and dial are less than optimum. Let's assume that a weak DX station you've been chasing is listed as transmitting on 15.370 MHz. Tune your receiver to WWV or WWVH and turn on the Super Marker. Place *S1* in the 100-kHz position, turn on the receiver's bfo and tune up three markers to 15.300 MHz. Place *S1* in the 50-kHz position and tune up one marker to 15.350 MHz. Next, place *S1* in the 10-kHz position and tune up two markers and open *S2*. Your receiver is now tuned to exactly 15.370 MHz. If propagation conditions are favorable, you'll hear the station with no need for further tuning.

If the desired station is transmitting at, say, 15.380 MHz, the procedure is less complicated. After tuning to 15.300 MHz, place *S1* in the 20-kHz position and tune up four markers to exactly 15.380 MHz. You can develop your own tuning procedures after you have logged some time practicing with the Super Marker. ◇