

An elegant 6-IC circuit gauges relative humidity

"It's not the heat, it's the humidity"—traditionally an easy claim to make and a difficult one to prove. But now a few low-cost devices and some novel circuit tricks simplify humidity measurements.

Jim Williams, National Semiconductor Corp

For use in critical applications such as food processing, paper and lumber production, pollution monitoring and comfort control, the humidity-meter design presented here requires only about \$30 worth of parts—in contrast to other configurations, which are far more expensive and often don't perform any better. This design also overcomes the calibration and signal-conditioning difficulties that complicate traditional approaches.

Consider some relatively simple concepts

The key to the relative-humidity (RH) meter lies in the signal conditioning it applies to the output of a humidity sensor. Fig 1 depicts such a transducer's sensing characteristic—an approximately exponential resistance change spanning nearly four decades. You can linearize this response by taking the logarithm of the sensor's resistance and utilizing a breakpoint-approximation technique to minimize residual non-linearities.

Consider further that no significant dc current component should be allowed to pass through the sensor; the device must be excited by an unbiased ac waveform to preclude detrimental electrochemical migration. Exhibiting a 0.36 RH-unit/°C positive temperature coefficient, the sensor consists of a chemically treated styrene copolymer, and because its humidity-sensitive portion resides at its surface, it responds fairly rapidly (on the order of seconds) to humidity changes.

Fig 2 illustrates the technique chosen to instrument the sensor. An amplitude-stabilized square wave (symmetrical about 0V) provides a precision alternating current through the sensor, satisfying the requirement for a zero-dc-component drive. To obtain a linear signal, the sensor's output feeds a current-sensitive logarithmic amplifier, whose input is at virtual ground. The circuit then scales, rectifies and filters this amplifier's output to provide a dc level proportional to relative humidity. In this final stage, breakpoint techniques compensate for residual nonlinearity arising from the sensor's nonlogarithmic response below 40% RH.

The hardware realization of these functions appears in Fig 3. Operating as a positive-feedback oscillator, A_{1A} outputs a symmetrical square wave (Fig 4) whose amplitude is stabilized by an LM334 current-source/diode-bridge combination. Biased by a 15Ω resistor, the 334 current-limits at about 5 mA, forcing

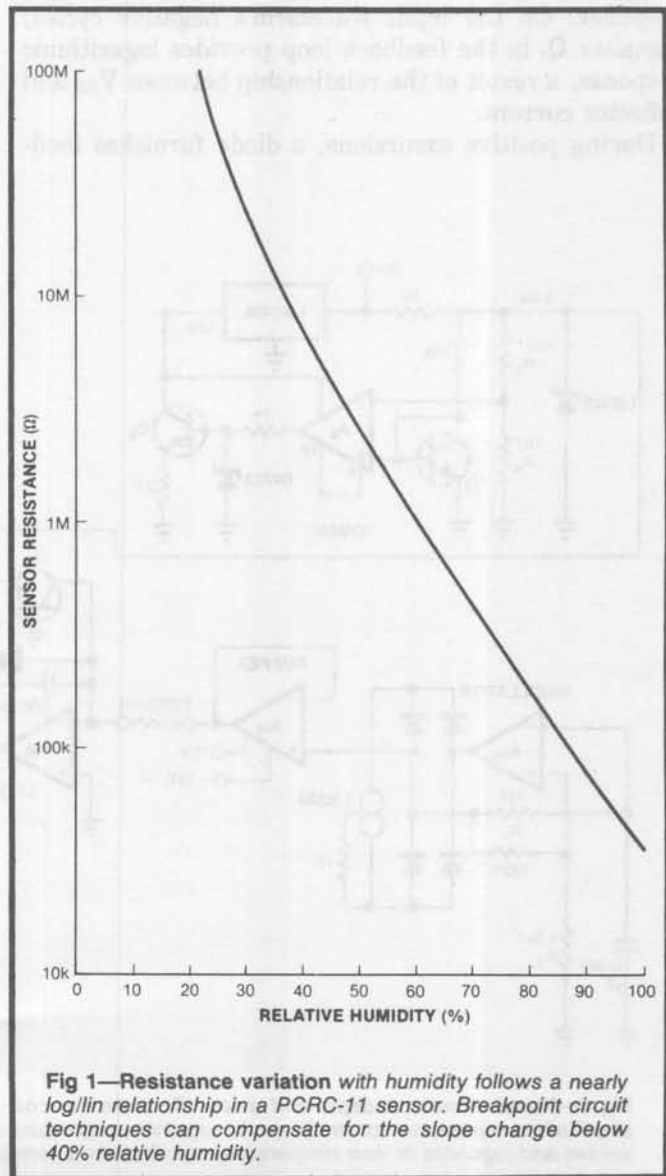

Fig 1—Resistance variation with humidity follows a nearly log/lin relationship in a PCRC-11 sensor. Breakpoint circuit techniques can compensate for the slope change below 40% relative humidity.

Accurate humidity measurement requires temperature stability

the voltage across a divider (R_1 , R_2) to stabilize at about $\pm 8V$. The waveform's amplitude stability depends upon the 334's $0.33\%/^{\circ}C$ temperature coefficient. (This TC was designed into the device to allow use in temperature-sensing and -compensation applications.)

The LM334's TC reduces the humidity sensor's $-0.36\%/^{\circ}C$ temperature dependence by more than an order of magnitude, causing the sensor's thermally induced inaccuracy to drop out as an error term. (In practice, mount the LM334 near the humidity sensor.) The residual $-0.03\%/^{\circ}C$ temperature coefficient is negligibly small compared with the sensor's $\pm 1\%$ accuracy specification and the circuit's overall 2% accuracy.

A transistor provides logarithmic response

Functioning as a buffer, A_{1B} drives a current through the sensor and into the summing junction of A_{1C} , the log amplifier. On the input waveform's negative cycles, transistor Q_1 in the feedback loop provides logarithmic response, a result of the relationship between V_{BE} and collector current.

During positive excursions, a diode furnishes feed-

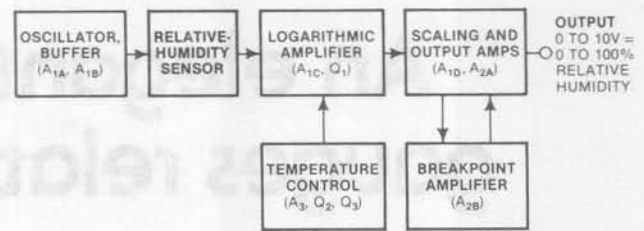

Fig 2—A humidity meter employs a sensor to convert a temperature-compensated square-wave voltage generator into a humidity-controlled current source. Logarithmic-to-linear signal conversion is followed by a scaling amplifier and a gain-corrected output stage. (Device designations in parentheses refer to Fig 3.)

back to the amplifier's summing junction. Thus, the summing junction always remains at virtual ground, while a negative-going square wave expresses the input current in logarithmic form at the transistor's emitter. Because the summing junction always remains at ground potential, the sensor sees the required symmetrical drive (Fig 5).

The log amplifier's output feeds to A_{1D} , an amplifier used to sum a 40%-RH trim with the main signal and provide adjustable gain to set a 100%-RH trim. A_{1D} 's output is filtered to dc and routed to A_{2A} , which unloads the filter and provides additional gain.

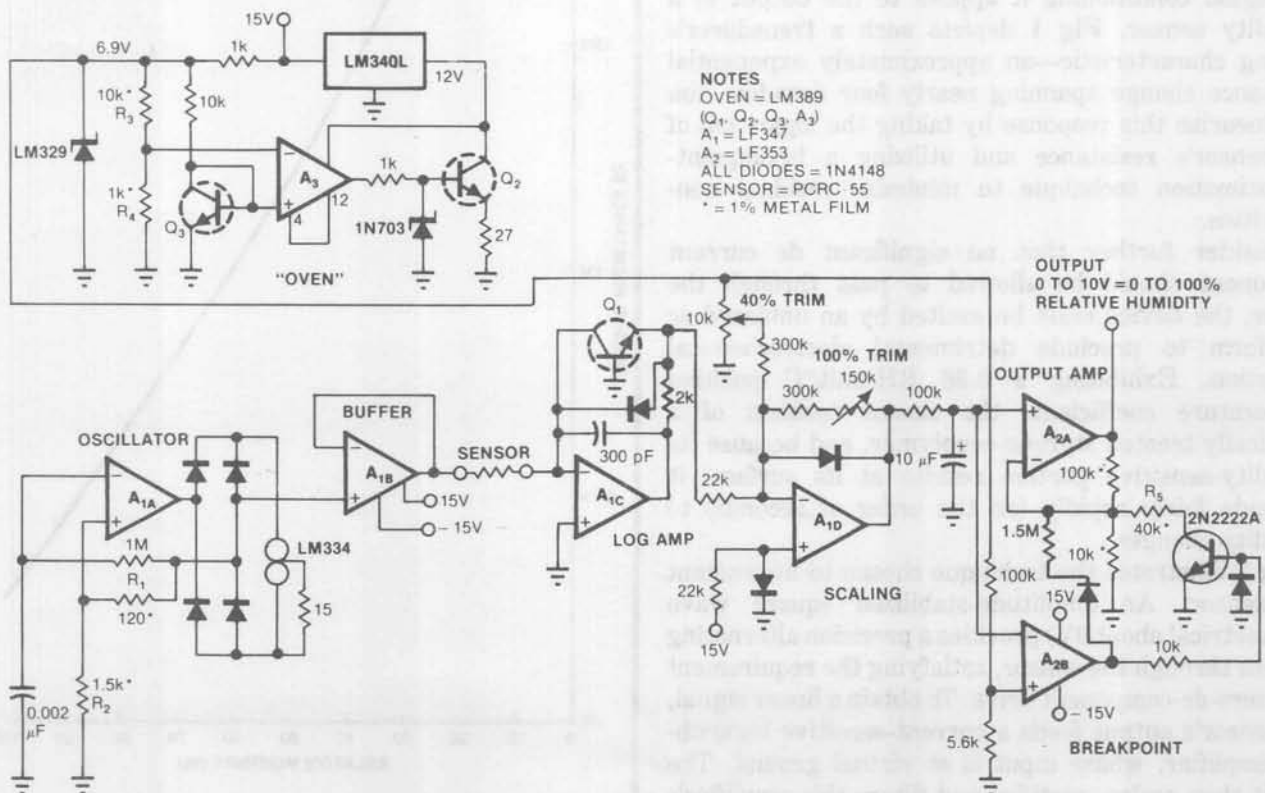

Fig 3—Novel circuit concepts and a few ICs make low-cost humidity measurement a reality. Controlling the A_{1A} oscillator's amplitude compensates for the sensor's negative temperature coefficient. An oven-like environment (within the LM389, which senses and regulates its own temperature) stabilizes the operation of logging transistor Q_1 .

Breakpoint amplifier A_{2B} compensates for the sensor's departure from logarithmic conformity below 40% RH by changing A_{2A} 's gain for RH readings below that level. It performs this function by sensing the input to A_{2A} and swinging positive when this input goes below RH=40 (about 0.36V at A_{2A} 's positive terminal). This swing turns a 2N2222A on, causing the required gain change at the output amplifier. For RH values above 40%, the transistor is OFF, and the log amplifier alone determines the circuit's linearizing function.

An IC becomes an oven

In a logarithmic configuration such as this circuit, Q_1 's dc operating point (and thus logging accuracy) varies wildly with temperature. This factor would normally mandate careful and extensive temperature compensation, which in turn would result in the expense normally associated with log amplifiers. But here, an LM389 (an audio-amplifier IC that also contains three discrete transistors) accomplishes the required temperature stabilization in a rather unorthodox—and inexpensive—manner.

LM389 transistor Q_3 functions as a chip-temperature sensor, while Q_2 , another of the device's transistors, serves as a heater. The 389's amplifier, A_3 , senses Q_3 's temperature-dependent V_{BE} and drives Q_2 , servoing the chip temperature to the setpoint established by a voltage divider (R_3 , R_4). Q_1 , the logging transistor, also resides in the 389 and thus operates in a tightly controlled thermal environment (typically at 50°C), immune to ambient-temperature shifts. (An LM329 voltage reference ensures power-supply independence for the temperature setpoint, and an LM340L 12V regulator provides safe operation from the 15V supply for the 12V temperature controller.)

How does the oven work? When the circuit first turns on, the voltage at Q_2 's emitter is about 3.3V, resulting in a current flow of 120 mA. This current forces Q_2 to dissipate about 1.5W, which raises the chip to operating temperature very rapidly. At this point, the thermal servo takes control and reduces the power.

The LM340 regulator has only 3V across it, so its dissipation never exceeds about 0.3W. A zener at the base of Q_2 prevents servo lockup during circuit initialization. Because the LM389's chip is small, it warms quickly and consumes little power.

Fig 6 shows the thermal servo's performance for a step function of 7°C change in setpoint. Note how the output responds almost instantaneously, and how complete settling to the new setpoint occurs within 100 msec.

Simple adjustments calibrate the circuit

To adjust this circuit, ground Q_2 's base, apply circuit power and measure Q_3 's collector potential at a known room temperature. Next, calculate Q_3 's collector potential at 50°C, allowing -2.2 mV/°C. Select R_4 's value (≈ 1 k Ω) to yield a voltage at A_3 's negative input close to the calculated 50°C potential. (This adjustment can be a fairly loose trim, because the exact chip

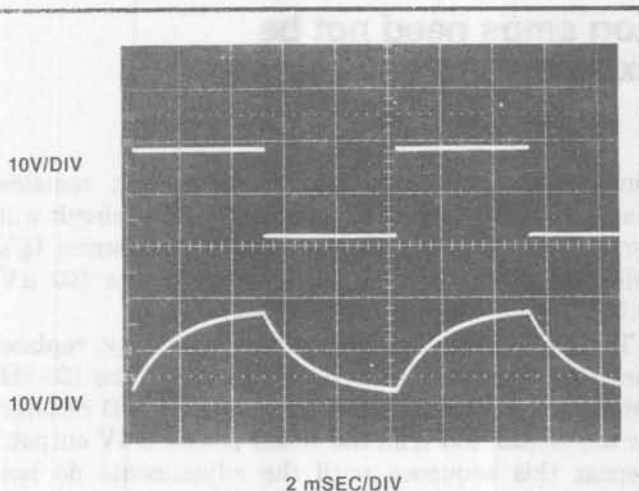

Fig 4—An amplitude-stabilized square wave (upper trace) drives the humidity sensor. Operating as a positive-feedback oscillator, A_{1A} in Fig 3 switches when its negative input port reaches threshold level (lower trace).

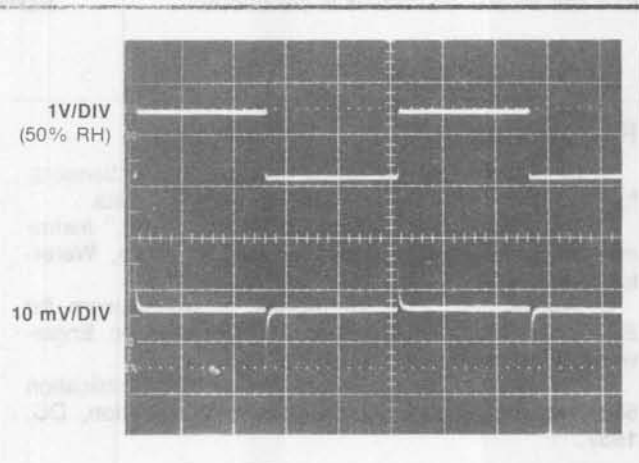

Fig 5—Sensor linearization is accomplished by the Q_1/A_{1C} stage in Fig 3. A signal at Q_1 's emitter (upper trace) is logarithmically converted and fed back to the op amp's summing junction (lower trace). The residual peaks cancel, leaving a true dc level proportional to measured humidity.

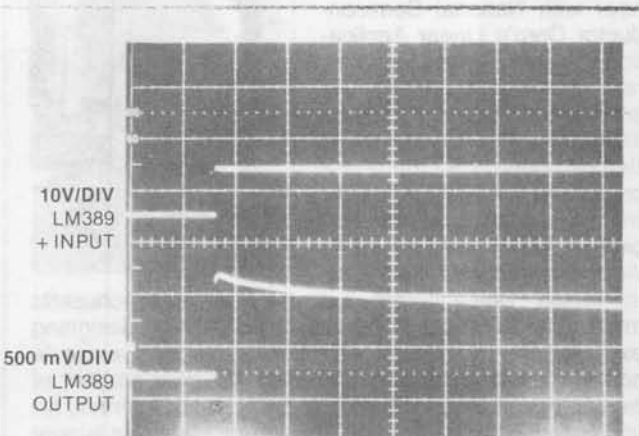

Fig 6—Rapid thermal regulation results with the LM389 "oven." The circuit completely stabilizes an equivalent 7°C change in setpoint temperature (upper trace) within 100 msec (lower trace).

Log amps need not be expensive to be accurate

temperature is unimportant so long as it remains stable.) Finally, unground Q_2 's base, and the circuit will servo. You can check this function by measuring Q_3 's collector voltage and noting stability within $100 \mu\text{V}$ (0.05°C) while blowing on the LM389.

To calibrate the circuit for relative humidity, replace the sensor with a $35\text{-k}\Omega$ resistor and trim the $150\text{-k}\Omega$ pot for a 10V output. Next, substitute a $5\text{-M}\Omega$ resistor for the sensor and trim the $10\text{-k}\Omega$ pot for a 4V output. Repeat this sequence until the adjustments do not interact with one another. Finally, substitute a $60\text{-M}\Omega$ resistor for the sensor and select an R_5 value (nominally $40\text{ k}\Omega$) for a reading of $\text{RH}=24\%$ (2.4V). The circuit is now calibrated and will read ambient relative humidity when the PCRC-55 sensor is connected. **EDN**

References

1. Phys-Chemical Research Corp, *Humidity Sensors*, for Models PCRC-11 and PCRC-55 technical data.
2. Widerhold, P R, "Humidity Measurement," *Instrumentation Technology*, General Eastern Corp, Watertown, MA.
3. Norton, Harry N, *Handbook of Transducers for Electronic Measuring Systems*, Prentice-Hall Inc, Englewood Cliffs, NJ, 1969.
4. Wexler, A, *Electric Hygrometers*, NBS Publication 586, National Bureau of Standards, Washington, DC, 1957.

Author's biography

Jim Williams, design engineer with National Semiconductor Corp's Linear Applications Group, Santa Clara, CA, has made a speciality of analog circuit design and instrumentation development. Before joining NSC, he was a consultant with Arthur D Little Inc in analog systems and circuits. From 1968 to 1977, Jim was director of the Instrumentation Development Lab at the Massachusetts Institute of Technology, where in addition to designing experimental biomedical instruments, he was active in course development and teaching. A former student of psychology at Wayne State University, he lists tennis, art and collecting antique scientific instruments as his leisure interests.

