

**POWER TOOL
OPERATION
MANUAL
&
PARTS LIST**

ELECTRIC

1/4" DRILL

Note: This manual covers three (3) models of this tool.
Check name plate on tool for your exact model.

- 1. STANDARD MODEL**
- 2. VARIABLE SPEED MODEL**
- 3. 2-SPEED MODEL**

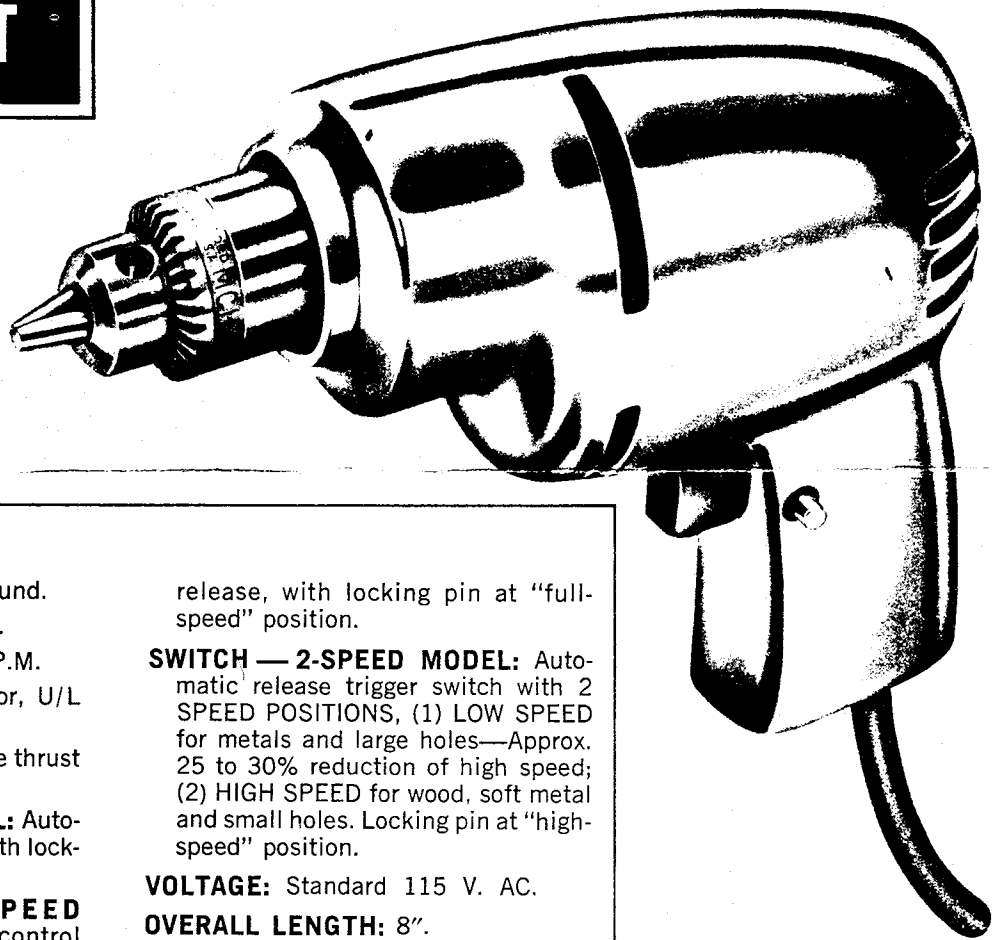

SPECIFICATIONS:

MOTOR: Universal—Series Wound.

NO LOAD SPEED: 2000 R.P.M.

FULL LOAD SPEED: 1200 R.P.M.

LEAD CORD: 6 Ft. 3 Conductor, U/L
Approved.

BEARINGS: Heavy Duty multiple thrust
ball bearings.

SWITCH—STANDARD MODEL: Auto-
matic release trigger switch with lock-
ing pin at "On" position.

**SWITCH — VARIABLE SPEED
MODEL:** Finger-tip speed control
from 0 to 2000 R.P.M. — Automatic

release, with locking pin at "full-
speed" position.

SWITCH — 2-SPEED MODEL: Auto-
matic release trigger switch with 2
SPEED POSITIONS, (1) LOW SPEED
for metals and large holes—Approx.
25 to 30% reduction of high speed;
(2) HIGH SPEED for wood, soft metal
and small holes. Locking pin at "high-
speed" position.

VOLTAGE: Standard 115 V. AC.

OVERALL LENGTH: 8".

NET WEIGHT: 3 lbs.

POWER TOOL DIVISION

2110 W. Walnut Street

Chicago, Illinois 60612

IN CANADA

1179 Finch Avenue

Downsview, Ontario, Canada

GUARANTEE

This tool is guaranteed against defective workmanship and materials from the established time of purchase for a period of ninety (90) days. Our obligation under this guarantee is limited to the repair or replacement, free of charge, to the original purchaser of any parts found to be defective upon examination, with the exception of cord and plug. **DO NOT ALTER THE CORD SET OR GROUNDED PLUG.** This guarantee shall not apply to items such as brushes, blades, and other wear accessories or where repairs have been attempted by unauthorized persons, or due to misuse or abuse or accident, neglect, or overloading. Where such things are apparent you will be notified as to cost of adjustment.

If service is required, ship tool **PREPAID** to our Factory, or Authorized Service Station. Include letter explaining nature of difficulty, date of purchase and enclose check or money order for \$1.50 to cover return postage and handling charges.

PARTS LIST

S=Standard Model/ V=Variable Speed Model/ 2=2-Speed Model

Part No.	Model	Description
2-3	S-V-2	Housing Screws (6)
2-4	S-V-2	Housing Handle Screw
2-8	S-V-2	Arbor Assembly
2-10	S-V-2	Front Armature Oil Plug
2-10	S-V-2	Arbor Oil Plugs (2)
2-10	S-V-2	Rear Armature Bearing Plug
2-10	S-V-2	Rear Armature Oil Plug
2-14	S-V-2	Steel Front Armature Washer
2-17	S-V-2	Ground Screw
2-19	S-V-2	Cord Assembly
2-21	S-V-2	Right Side Casting
2-22	S-V-2	Left Side Casting
2-23	S-V-2	Armature & Fan
2-24	S-V-2	Field
2-25	S-V-2	Field Spring (not shown)
2-26	S	Switch Assembly
250-26	V	Switch Assembly
4-6	2	Switch Assembly
3-7	S-V-2	Rear Armature Washer
250-8	S-V-2	Brush Holders (2)
250-7	S-V-2	Brushes & Springs (2)
4-9	S-V-2	Rear Arbor Bearing
100-16	S-V-2	Front Arbor Bearing
100-17	S-V-2	Front & Rear Armature Bearing
250-10	S-V-2	Geared Chuck
250-11	S-V-2	Chuck Key (not shown)
250-15	S-V-2	Ball Bearing & Thrust Washers
250-20	S-V-2	Front Armature Washer

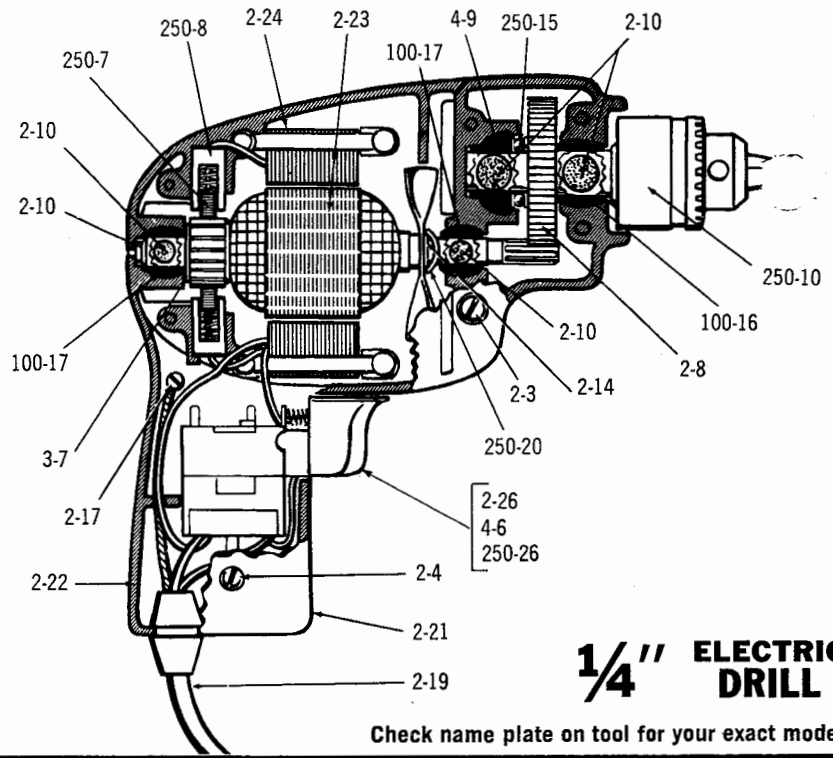

1/4" ELECTRIC DRILL

Check name plate on tool for your exact model.

OPERATING INSTRUCTIONS

LUBRICATION: To re-lubricate, remove the gear box and gear box cover and flush out all the old grease. (Use a good grease solvent). Re-pack gear box with a good quality lithium-soap base grease of No. 2 consistency, about $\frac{1}{2}$ full. This re-lubrication should be done every 6 months, depending upon the use of the drill.

The rear armature bearing should be oiled (every 3 to 4 months under normal usage) with S.A.E. No. 10 motor oil, applied through oiling hole or rear of the drill housing.

BRUSHES: Severe damage to the armature can result if brush replacement is not performed. Brushes should be replaced when worn $\frac{3}{16}$ " to $\frac{1}{4}$ " in length.
CHUCK: A. Always insert drill bit far enough into the chuck so that the full length of the chuck jaws are brought to bear. B. Don't overload the chuck by using a larger drill bit than capacity of chuck will allow. C. A small drop of oil, periodically placed inside chuck jaws will ensure long life and ease of operation.

The following gauges of EXTENSION CABLES should be used. **25 to 50 feet use 18 gauge, 75 to 100 feet use 16 gauge.**

DRILLING TIPS

Use center punch on metal surfaces, to insure proper hole placement.

Keep drill bits sharp for greatest accuracy.

Light, even pressure produces best work faster and cleaner. Under heavy pressure drill may stall or lose speed. If this happens, release pressure against work and allow drill to regain full speed.

Drill small hole first—follow with larger drill bit for more accuracy and satisfaction.

Keep body of drill and drill bit in line with each other during drilling operations. Keep drill clean and dry. Don't allow cord to become scraped or broken.

KEEP THIS MANUAL IN A SAFE PLACE

Fill out and return **GUARANTEE CARD**.
 Guarantee void unless card is returned within 10 days from date of purchase.

HOW TO ORDER PARTS

- Order by Part Number and Description.
- Specify Model and Serial Number (see name plate on tool.)
- Check enclosed list of Authorized Service Stations—order from the one nearest you.

ELECTRICAL CONNECTIONS. GROUNDING—This electric tool is equipped with an Underwriters' Laboratories approved 3 prong plug for your safety. The longer prong in this plug is connected through the power cord to the tool housing.

When the plug is inserted in a properly grounded receptacle box, it will protect the user from shock, should the drill insulation for any reason fail.

If you use an extension cord with this tool it should also be 3 wire.

Since many receptacle boxes in present construction will not have provision for 3 prong plugs, an adapter is available for this tool. Make sure grounding lead is firmly attached to a grounded receptacle box as shown below, before attempting to operate the tool.

* Not Used in Canada

3 conductor adapter plug not included.

