

instructions

FOR THE



RF PROBE

Model PK-3

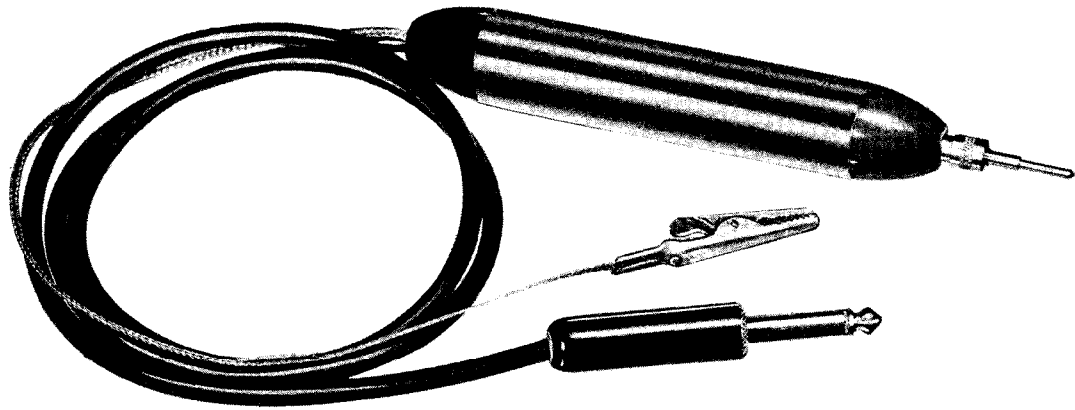

INTRODUCTION

The Heathkit Model PK-3 RF Probe expands the usefulness of any 11 megohm DC input voltmeter by providing an RF voltage measurement capability. The crystal diodes provide a frequency response that is flat and linear from 1000 hertz to over 100 megahertz. Printed circuit board wiring reduces circuit capacitance, improving high frequency response. The grounded probe body housing and short input leads prevent hand capacitance effects and extraneous signal pickup from producing false voltage readings.

All readings obtained will be in rms (root-mean-square) volts. RF voltages of 90 volts or less can be easily measured, as well as RF voltages superimposed on DC potentials of 1000 volts or less. Accuracy of the Probe is maintained within approximately 10%, which is adequate for most RF work. Provisions for improved accuracy at low RF voltages (less than 1 volt) are explained in the Step-By-Step Assembly. If this change is incorporated, the maximum RF voltage that can be measured will be 30 volts rms.

STEP-BY-STEP PROCEDURE

Unpack the kit and check each part against the Parts List. Then proceed with the Step-By-Step Assembly.

For best soldering results, a 25 to 50 watt iron is recommended. The tip should be clean and well tinned in order to obtain a quick, clean solder joint. Hold the tip of the iron at the junction of the component lead and the circuit board conductor, and apply good solder at the same point until a good connection is obtained between the two parts. When all parts are clean, the connection can be made very quickly, preventing heat damage to resistors, capacitors, and diodes.

ROSIN CORE SOLDER IS SUPPLIED WITH YOUR KIT. THIS TYPE OF SOLDER MUST BE USED FOR ALL SOLDERING IN THE KIT. THE USE OF OTHER TYPES OF SOLDER VOIDS THE WARRANTY, AND WE WILL NOT SERVICE EQUIPMENT IN WHICH ACID CORE SOLDER OR PASTE FLUXES HAVE BEEN USED.

FOR GOOD SOLDERED CONNECTIONS, YOU MUST KEEP THE SOLDERING IRON TIP CLEAN...

WIPE IT OFTEN WITH A DAMP SPONGE OR CLOTH.

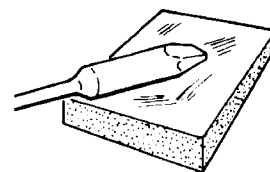

PARTS LIST

PART No.	PARTS Per Kit	PRICE Each	DESCRIPTION	PART No.	PARTS Per Kit	PRICE Each	DESCRIPTION
1-39	1	.10	4.7 MΩ (yellow-violet-green) 5% resistor	477-3	1	.20	Solderless probe tip
21-43	1	.10	.001 μF disc capacitor	391-34	1	-	Blue and white label
56-26	3	.25	1N191 crystal diode	597-260	1	-	Parts Order Form
70-4	1	.10	Insulator sleeve	597-413	1	-	Instruction Sheet
85-275	1	.35	Circuit board	331-6	1	.15	Solder
250-212	4	.05	2-56 x 3/16" self-tapping screw				
260-1	1	.10	Alligator clip				
340-2	1	.05/ft	Bare wire				
343-2	1	.10/ft	Shielded cable				
345-1	1	.10/ft	Flat braid				
390-13	1	.10	Label				
438-3	1	.45	Phone plug				
459-2	1	.15	Red probe end				
459-3	1	.10	Black probe end				
476-8	1	.40	Aluminum probe body				

The above prices apply only on purchases from the Heath Company where shipment is to a U.S.A. destination. Add 10% (minimum 25 cents) to the price when ordering from an authorized Service Center or Heathkit Electronic Center to cover local sales tax, postage and handling. Outside the U.S.A. parts and service are available from your local Heathkit source and will reflect additional transportation, taxes, duties and rates of exchange.

STEP-BY-STEP ASSEMBLY

CIRCUIT BOARD ASSEMBLY

Parts will be installed on the circuit board in the following steps on Pictorial 1. Position the circuit board as shown. All parts will be mounted on the plain side of the circuit board, with

the leads coming out the foil side. Generally, it is best to mount all parts before soldering. Bend the leads over slightly as you install each part to lock it in place until the leads are soldered. Proceed to Pictorial 1.

START

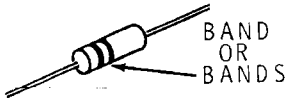

(✓) 2" bare wire. Solder this wire to the foil and cut off the excess lead length. The other end will be connected later.
(✓) .001 μ F disc capacitor.
() 4.7 M Ω (yellow-violet-green).
NOTE: When mounting crystal diodes in the next steps, position the cathode end of each diode as shown. The cathode end is marked with a band or bands.

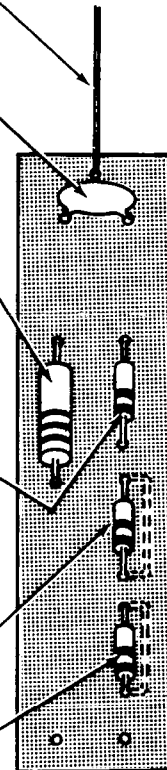
() Crystal diode.
NOTE: If all applications for which you plan to use this probe involve RF voltages of less than 30 volts rms, substitute a length of bare wire (excess lead cut from the resistor) in place of each of the next two diodes. This will increase the accuracy of the probe at very low voltages (less than 1 volt), but will limit the maximum RF voltage to 30 volts rms.
(✓) Crystal diode or bare wire.
(✓) Crystal diode or bare wire.
() Solder all leads to the foil and cut off the excess lead lengths. Do not cut off the length of bare wire.

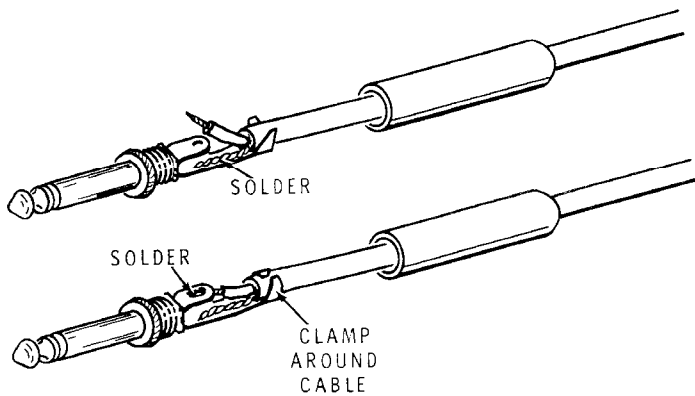

Proceed to the Cable and Probe Body Assembly

PICTORIAL 1



PICTORIAL 2

CABLE AND PROBE BODY ASSEMBLY

Refer to Pictorial 2 for the following steps.

- (1) Refer to Detail 2A and prepare the shielded cable as shown.
- (2) Unscrew the cap from the phone plug.
- (3) Insert the end of the shielded cable with the $\frac{3}{4}$ " center conductor through the phone plug cap.
- (4) Twist the shield wires into one strand and apply a small amount of solder to hold the separate strands together. Take care not to melt the inner insulation.

NOTE: In the following steps you will connect the prepared cable to the phone plug as shown in Pictorial 2. To avoid overheating the cable insulation, first apply a film of solder to the phone plug terminals; then hold the wires to the phone plug and apply just enough heat to melt the solder.

PREPARE EACH END AS SHOWN.

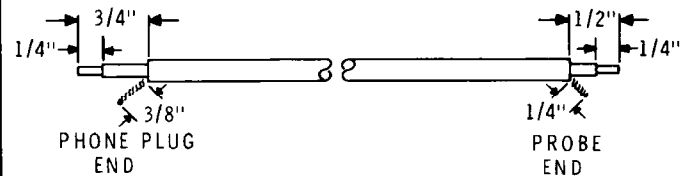

TAKING CARE NOT TO CUT THE OUTER SHIELD OF VERY THIN WIRES, REMOVE THE OUTER INSULATION.

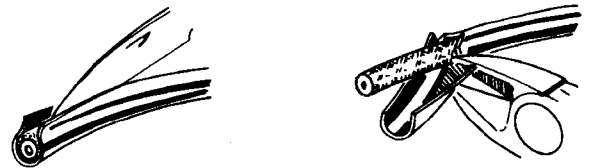

UNBRAID THE SHIELD WITH A NAIL OR POINTED TOOL AND TWIST THE SHIELD WIRES INTO ONE STRAND. REMOVE THE INNER INSULATION. THEN APPLY A SMALL AMOUNT OF SOLDER TO THE END OF THE CENTER CONDUCTOR.

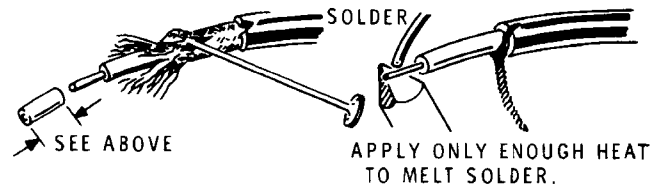

Detail 2A

- (5) Refer to Pictorial 2 and solder the shield wire to the phone plug. Be careful not to melt or burn the inner plastic insulation of the shielded cable.
- (6) Solder the inner wire of the shielded cable as shown. Be sure the phone plug cap will still fit over the wires. Use only enough heat to melt the solder and make a good connection.
- (7) After the wires have completely cooled, use pliers to bend the tabs on the phone plug over to secure the cable.
- (8) Screw the cap onto the phone plug.

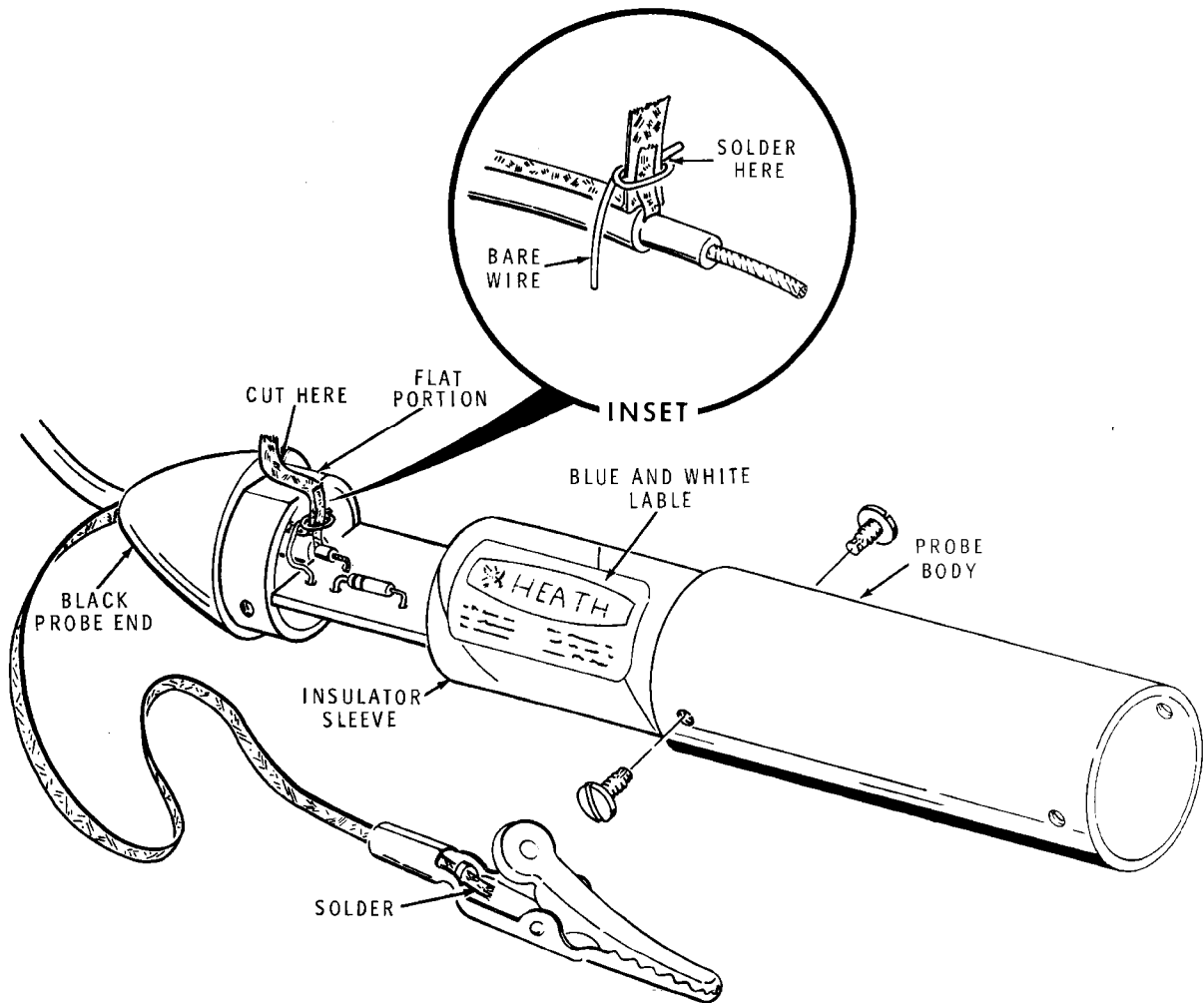

PICTORIAL 3

Refer to Pictorial 3 for the following steps.

- (✓) Place the flat braid and the free end of the shielded cable through the black probe end.
- (✓) Bend the flat braid 1" from the end and position it against the shield of the shielded cable as shown in the inset drawing of Pictorial 3.
- (✓) Wrap one end of a 1-1/2" bare wire around the two shields and apply a small amount of solder. Be careful not to melt the inner insulation of the shielded cable.
- (✓) Position the circuit board as shown and insert the bare wire into the circuit board hole closest to the crystal diode (or closest to the bare wire taking the diodes place) (S-1).
- (✓) Insert the inner conductor of the shielded cable into the remaining hole (S-1).
- (✓) Cut off the excess lead lengths.
- (✓) Slide the black probe end against the circuit board.
- (✓) Bend the flat braid over the flat portion of the probe end. Cut off any excess braid.
- (✓) Remove the paper backing from the blue and white label. Then press the label on the side of the insulator sleeve.
- (✓) Install the insulator sleeve over the circuit board.
- (✓) Install the probe body over the insulator sleeve and onto the probe end. Be sure the flat braid is positioned on the flat portion of the probe end.
- (✓) Align the holes in the probe body with those in the probe end and install two 2-56 x 3/16" self-tapping screws.
- (✓) Insert the free end of the flat braid into the alligator clip and solder as shown in Pictorial 3.

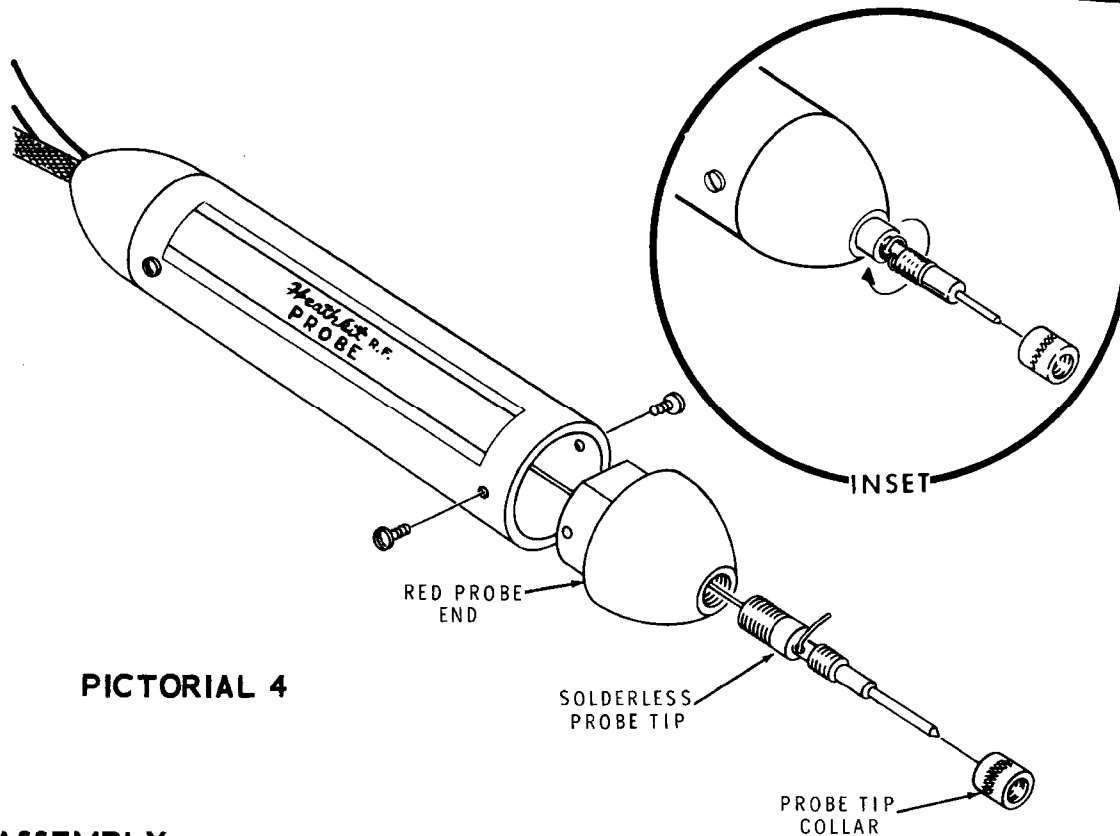

PICTORIAL 4

PROBE TIP ASSEMBLY

Refer to Pictorial 4 for the following steps.

- () Install the solderless probe tip into the red probe end and remove the probe tip collar.
- () Insert the red probe end into the probe body, making sure the bare wire from the circuit board appears through the hole in the side of the probe tip.
- () Align the holes in the probe body with those of the probe end and install two 2-56 x 3/16" self-tapping screws.

- () Wrap the wire extending through the probe tip clockwise around the tip as shown in the inset drawing of Pictorial 4.
- () Install the probe tip collar.
- () Remove the "RF Probe" label from the label sheet and place it on the probe body. Discard the other labels.

This completes the assembly of the Probe.

APPLICATION

The PK-3 RF Probe can be connected to any 11 megohm input DC voltmeter. The output voltage of the Probe is negative DC, and the voltmeter should be set accordingly. It may be used as a signal tracer and gain analyzer, as well as an RF voltage measuring device. Also, because this Probe is designed primarily for RF applications, signals below 1000 hertz will read low. Disconnect the RF Probe and use the AC section of the voltmeter for these low frequencies. (NOTE: The capacitive effect of the AC test leads will be negligible at frequencies below 1000 hertz.)

If a receiver is not functioning properly, the Probe can be used as a signal tracer in the following manner: First, connect the Probe to the plates of the second detector stage and note the amount of RF energy that is present there. If there is no indication, move the Probe back to the plate of the last IF stage and observe the meter again. If there still is no indication, move the Probe to the grid of this stage and, if necessary, further forward toward the RF input in this step-by-step manner. The point at which RF energy first appears will indicate that the trouble is in the circuit immediately following

this point. (Local oscillator operation can be checked by connecting the Probe to the grid or cathode of the oscillator tube.) Transistor circuits may also be tested in a similar manner. Remember that probe sensitivity is limited by the sensitivity of the voltmeter, so it is unlikely that you will obtain satisfactory indications in the RF and mixer stages of a receiver.

Use this same procedure to check RF or IF amplifier gain. Write down the readings you obtain and divide the output voltage by the input

voltage. The answer you obtain will be the gain of the stage or stages.

RF signals present in transmitters can also be measured, providing the ratings of the probe are not exceeded.

Remember that 90 volts is the maximum AC voltage that should be applied to the Probe. DC voltages up to 1000 volts can be connected to the Probe safely as long as the superimposed RF voltage does not exceed the 90 volt limit.

CIRCUIT DESCRIPTION

DC isolation is provided by the .001 μ F capacitor. Since this input capacitor is rated at 1000 volts DC, the Probe must not be applied to circuits where DC voltages are higher than this.

An RF signal at the probe tip will be coupled through the low impedance of the input capacitor to the 4.7 megohm resistor and the crystal

diodes. The positive half-cycles of the RF signal are grounded through the crystal diodes. The remaining negative half-cycles are filtered by the 4.7 megohm resistor and the cable capacitance, and appear at the input of the meter as a negative DC voltage. The filter resistor forms a voltage divider with the input resistance of the meter to provide an rms voltage (70% of the negative peak) to the meter input.

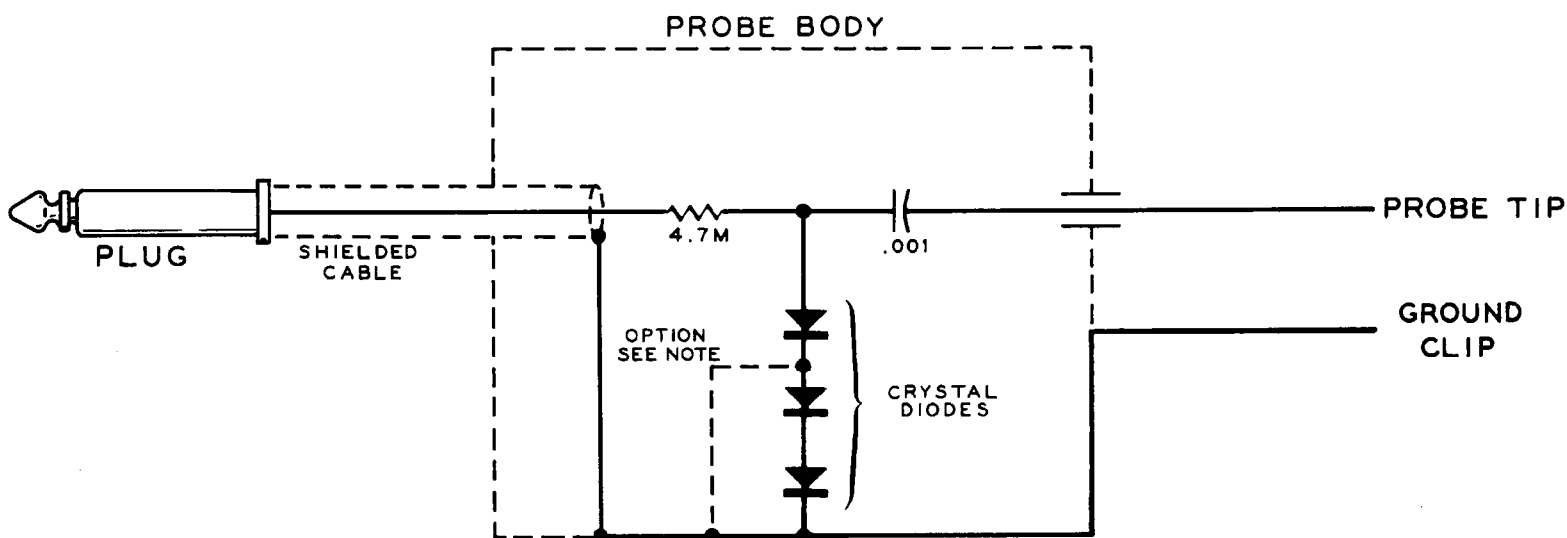

NOTE: REFER TO PICTORIAL 1 OF THE STEP-BY-STEP ASSEMBLY FOR OPTIONAL WIRING.

SERVICE

If the unit does not function properly, recheck the wiring and solder connections. Also check the connector (s) on the end of the cable. Be sure the connections are made correctly and that there are no short circuits.

FACTORY REPAIR SERVICE

You can return your completed kit to the Heath Company Service Department to have it repaired for a minimum service fee. (Kits that have been modified will not be accepted for repair.) If you wish, you can deliver your kit to a nearby Heath Authorized Service Center. These centers are listed in your Heathkit catalog.

To be eligible for replacement parts under the terms of the warranty, equipment returned for factory repair service, or delivered to a Heath Authorized Service Center, must be accompanied by the invoice or the sales slip, or a copy of either. If you send the original invoice or sales slip, it will be returned to you.

If it is not convenient to deliver your kit to a Heath Authorized Service Center, please ship it to the factory at Benton Harbor, Michigan and follow the following shipping instructions:

Prepare a letter in duplicate, containing the following information:

- Your name and return address.
- Date of purchase.
- A brief description of the difficulty.

- The invoice or sales slip, or a copy of either.
- Your authorization to ship the repaired unit back to you C.O.D. for the service and shipping charges, plus the cost of parts not covered by the warranty.

Attach the envelope containing one copy of this letter directly to the unit before packaging, so that we do not overlook this important information. Send the second copy of the letter by separate mail to Heath Company, Attention: Service Department, Benton Harbor, Michigan.

Check the equipment to see that all parts and screws are in place. (Do not include wooden cabinets when shipping receivers, tuners, amplifiers, or TV sets, as these are easily damaged in shipment.) Then, wrap the equipment in heavy paper. Place the equipment in a strong carton, and put at least **THREE INCHES** of resilient packing material (shredded paper, excelsior, etc.) on all sides, between the equipment and the carton. Seal the carton with gummed paper tape, and tie it with a strong cord. Ship it by prepaid express, United Parcel Service, or insured parcel post to:

Heath Company
Service Department
Benton Harbor, Michigan 49022

The Heath Company reserves the right to discontinue instruments and to change specifications at any time without incurring any obligation to incorporate new features in instruments previously sold.

WARRANTY

The Heath Company warrants parts in its kits for 90 days after shipment. Under this warranty, we will exchange any defective part returned prepaid within the 90 days. If a part is defective, its replacement is shipped prepaid by us anywhere in the continental United States or to APO and FPO addresses. Shipments to all other areas are FOB factory. Heath's obligation is limited to such replacement or repair by Heath, and Heath is not responsible under this warranty or otherwise for any consequential damage or other loss in connection with the purchase, assembly, or use of the kit or parts. Use the Parts Order Form in the kit to notify us of the defective part and return instructions will be sent to you, or contact any Heathkit Electronic Center.

Questions relating to repairs or warranty replacement in the continental United States (APO and FPO included) should be addressed to Heath Company, attention: Customer Relations, or the nearest Heathkit Electronic Center. In all other areas please contact the authorized Heathkit representative in your country, or Heath Company, attention: International Division.

HEATH COMPANY
Benton Harbor, Michigan 49022