

Servicing the Hitachi VM Series camcorder

By Timothy W. Durhan

VHS camcorders from all manufacturers have a lot in common. They have to have a lot of similarities in order to record and play back on the same VHS tape cassette. On the other hand, manufacturers also have a great deal of freedom in the details of how they design and construct their camcorders.

This article will describe procedures for servicing Hitachi models VM 3000 through VM 5000 camcorders. Many of the problem symptoms and actions to correct the problems will also apply to other brands and models of camcorder.

Hitachi manufactured thousands of camcorders in the late 80's as models VM 3000 to VM 5000. Radio Shack, RCA and Sears sold these units too, using their own names and model numbers. All feature the same tape mechanism. The capstan,

Durhan is an independent consumer electronics servicing technician and a freelance technical writer.

mode cam and tape wind functions are actuated by belts.

Symptoms of worn rubber parts

You probably know rubber parts deteriorate in time, even if they're not used often. Chances are, a five or six year old camcorder will need new rubber. Some common symptoms of worn belt problems include:

- Tape starts to load, then camcorder shuts off.
- *Tape runs, then after a while, shuts off.
- Camcorder eats tapes.
- Tapes won't play or record.

If you have serviced VCRs with similar problems, you know it's not too difficult to replace worn rubber parts.

Many VCR technicians are reluctant to service camcorders, even though they wouldn't think twice about opening up

and repairing a hand held remote control. If you can repair a remote control unit without destroying the case or losing any of the buttons, performing a mechanical repair on a camcorder shouldn't be too difficult. Lost screws, pinched wires and broken pc boards can be avoided by using a systematic disassembly and reassembly procedure.

Getting started

Start by powering up the camcorder using the customer's ac adapter, since a defective battery may also be the cause of any of the symptoms mentioned earlier. Moreover, there is nothing more frustrating than running out of power in the middle of a repair. If your customer didn't include the adapter along with their camcorder, put this repair on hold until they do.

Slide the power switch to on, and press eject. If the mode belt is in good shape, the cassette lid should pop up. If it doesn't

1. Upper Cylinder (Video Head)
2. Audio/Control (A/C Head)
3. Dew Sensor
4. Pressure Roller
5. Capstan Motor
6. Capstan Flywheel
7. Take-up End Sensor
8. Take-up Reel Disk
9. End Lump
10. Take-up Guide Roller
11. Supply Reed Disk
12. Tension Band
13. Tension Arm
14. Supply Guide Roller
15. Supply End Sensor
16. Impedance Roller
17. Full Erase Head
18. Cylinder Brush

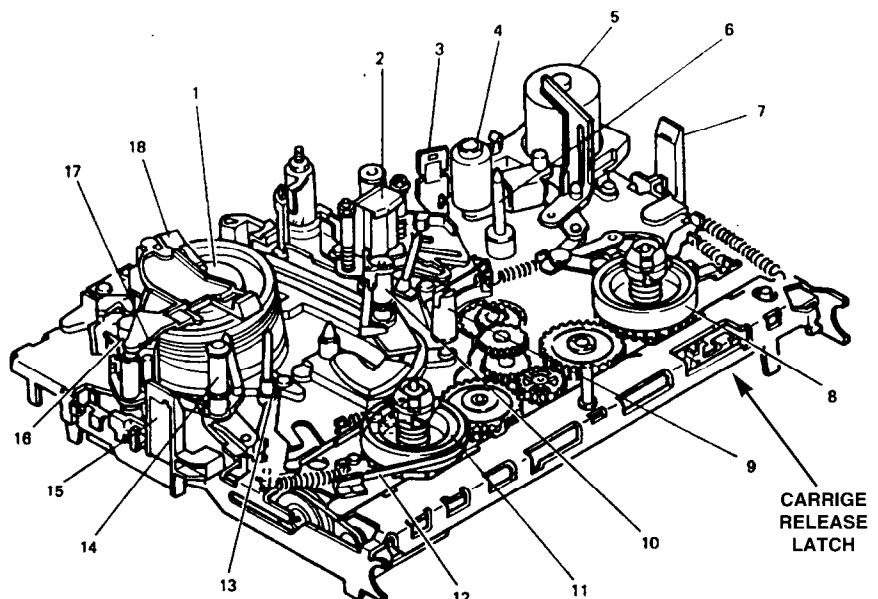

Figure 1. Tape transport mechanism-Top View.

open, you'll have to trigger the carriage latch manually.

To open this latch manually, unplug the ac adapter and remove the two screws that hold the cassette lid on. Carefully slide off the lid, and set it out of your way. On the right side at the top edge of the chassis is a tiny latch (Figure 1). Gently move the latch to one side with a small screwdriver or pick. The housing should pop up, and you can remove the video tape, if one is stuck inside.

Performing the diagnosis

Once the cassette lid is off, power-up the camcorder again. Cover up the sense LED in the center of the transport with black tape or other suitable light shield, and press play. Again, if the mode belt is in good shape, the guide posts should move to their stoppers, and the drum will start to spin.

To determine whether the tape-wind belt is doing its job, use a torque gauge on the take-up spindle. Hitachi recommends 80gm-cm to 1 10gm-cm. If you lack such a handy tool, you can try to stop the spindle with your fingers. Obviously, if the spindle doesn't turn, or stops very easily, the tape-wind belt is defective. Is the pinchroller turning?

If the take-up spindle and pinchroller aren't moving, the capstan belt is defective, or there may be an electronic fault. Listen closely for the sound of the capstan motor spinning. You will have to press the play button continually in this

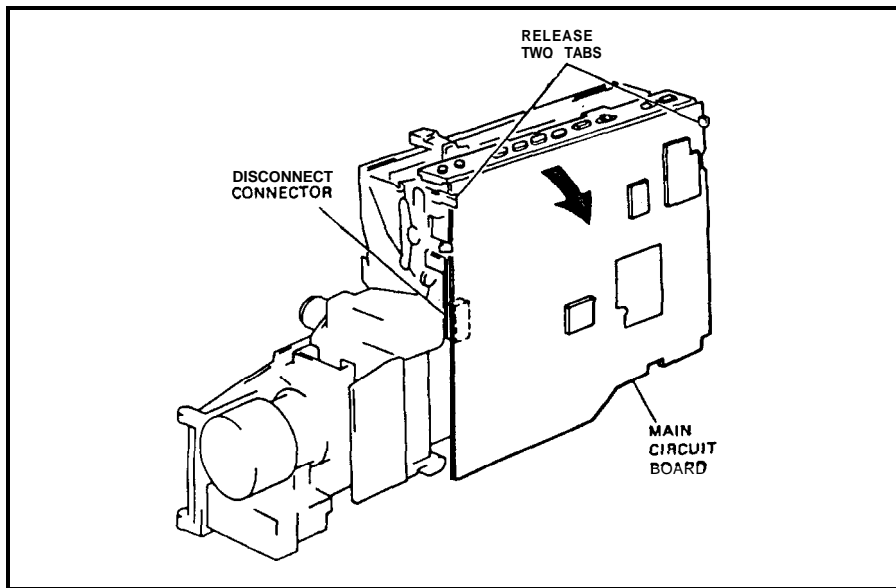

Figure 2. Jack circuit board removal

condition, because the lack of pulses from the capstan and take-up sensors will alert the system control microprocessor to enter the protection mode, and the camcorder will shut off.

If you have checked all of these functions, and have determined that a belt may need to be replaced; replace them all.

There are only three belts on the mechanism, and since they were all manufactured at the same time, if one is worn, the other two can't be far behind.

Belt part numbers 6356445, 6356472 and 6358012 should be available from any Hitachi part distributor. Use numbers 174757, 174758 and 174759 if you want

to order your parts from RCA instead of ordering from Hitachi.

Getting to the belts

To begin, remove the covering from the sense LED you put on earlier. Close the cassette holder, (if you can). Unplug the adapter cable to give yourself more room. Unplug and remove the viewfinder.

Lay the camcorder on its side, with the cassette housing facing down, and the lens assembly pointing to your left. Remove the screws that hold the case shells together. Next, carefully pull the shell that's facing you off and set it aside.

Release the main pc board from the two

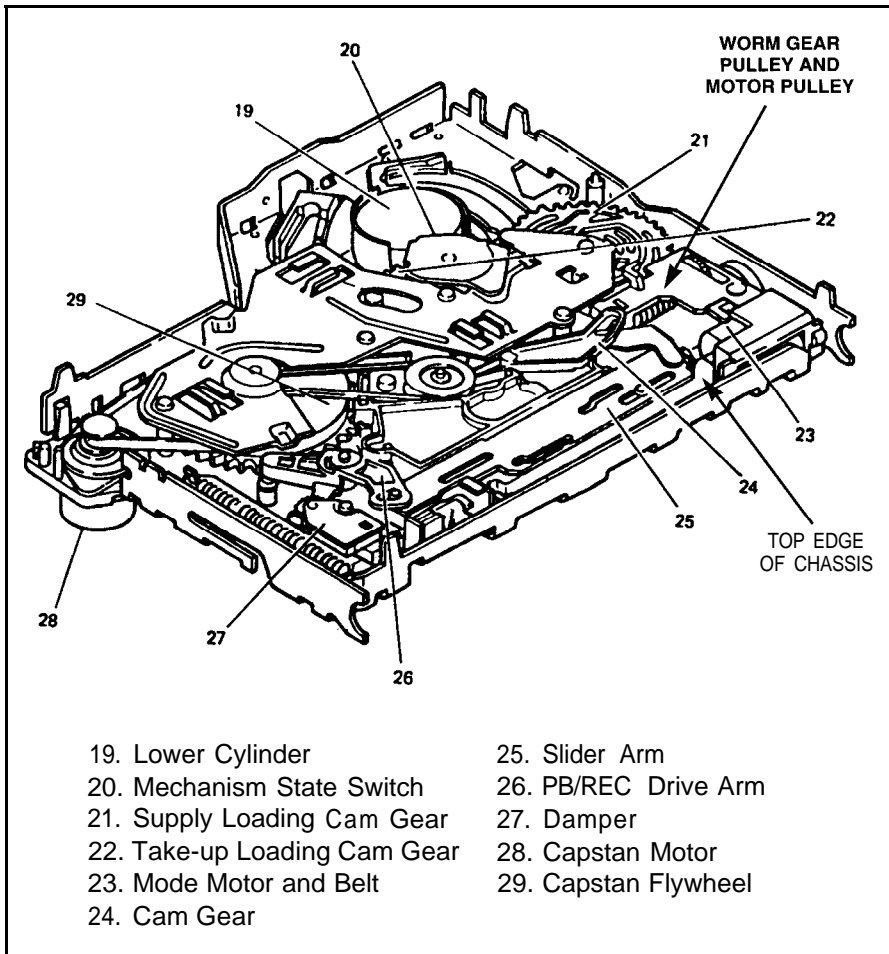

Figure 3. Tape transport mechanism- Bottom view.

white clips on both sides (Figure 2) and slide the control pc board (buttons and all) slowly toward you. Unplug the small connector from the bottom of the main pc board, and remove the large wiring harness from its holder. This should allow you to tilt the board for free access to the tape mechanism.

Next, remove the plastic sheet covering the capstan pulley. Locate and remove the screws and cover holding the flywheel in place, and lift off the cover. Remove the old belts and clean the gum deposits off the pulleys with a solvent, such as alcohol or acetone.

Replacing the belts

Replace the capstan belt, then the tape-wind belt. Rotate the flywheel by hand to insure that there are no twists in the belts, and remove any grease that may have found its way onto the new belts.

Reinstall the flywheel cover and screws. Reinstall the plastic sheet and

inspect the area for wiring that may interfere with any movement of the mechanism. It's a tight squeeze, but you can take off the mode belt from the motor pulley and worm gear pulley without removing either one.

Located in the top left corner (Figure 3), these pulleys should be cleaned too. Again, make sure there are no twists or excess grease on the new belt.

While you have the case off, it's a good idea to use a small soft brush to clean out the dirt and dust that has found its way inside. Reinstall the connector to the main pc board, tuck the large wiring harness back into its holder and slide the control pc board into the slots on the top case. Then snap the main pc board back into the clips that hold it in place.

The finishing touches

Next, turn the camcorder over and remove the other side shell. Clean the video heads, lower cylinder lip, guides, guide

rollers, pinchroller, ACE heads, impedance roller and capstan shaft with isopropyl alcohol (or other suitable chemical).

Always be extremely careful when cleaning the video heads. Follow the manufacturer's directions carefully, and use only specially made plastic foam or chamois leather swabs.

Remove any excess grease and dirt with Q-tips or a soft brush. Reinstall the side shells and viewfinder.

Before powering up the camcorder, clean the lens and viewfinder window with a lens cleaning solution and lens tissue (available at any retail camera store). Then connect the camcorder and TV (or monitor) to the ac adapter and plug it in.

Slide the power switch to on, press eject and put in a tape to test play quality. If everything is in order, you should have a clear picture on the screen and in the viewfinder. Make sure that the audio is playing back at the proper level and that it is not distorted.

Perform a thorough operational test

Stop and eject your play test tape and insert a tape you can record on. Remove the lens cover and put the camcorder into the record mode. While recording, use the zoom, focus and other features on the camcorder to verify that everything is working properly, and that no connectors are loose. Playback your recording and check the video and sound for accurate and natural qualities.

Because you didn't disturb any electrical circuitry or tape path geometry, you won't need expensive jigs, charts or other test equipment for a repair job such as this. Replacement of pc boards, power supply components or the CCD and associated parts would require a more involved repair and adjustment procedure.

If, after a few belt and cleaning jobs, you like the challenge that a camcorder provides, there are books available from Ryder Press, Howard Sams and others that deal with camcorder theory and operation in full detail. Also, Philips of North America, and others, have classroom education on camcorder repair.

Camcorders manufactured in the 90's require more elaborate test jigs and contain exotic concepts never thought of in the 80's. But isn't the same true in other areas of electronics? ■