

HISTORY INFORMATION FOR THE FOLLOWING MANUAL:

# SERVICE MANUAL

# AX1 CHASSIS

<u>MODEL NAME</u>	<u>REMOTE COMMANDER</u>	<u>DESTINATION</u>	<u>CHASSIS NO.</u>
<b>KDP-51WS550</b>	RM-Y192	US/CND	SCC-M11CA
<b>KDP-57WS550</b>	RM-Y192	US/CND	SCC-M11AA
<b>KDP-65WS550</b>	RM-Y192	US/CND	SCC-M11BA

## ORIGINAL MANUAL ISSUE DATE: 7/2003

 :UPDATED ITEM

<u>REVISION DATE</u>	<u>REVISION TYPE</u>	<u>SUBJECT</u>
7/2003		No revisions or updates are applicable at this time.
7/25/2003		Updated Table of Contents (Replaced Page 3 with Page 3) Updated 2-4. Focus Lens Adjustment step #11 (Replaced Page 17 with Page 17), Exchanged order of procedures for 2-6. & 2-7. (2-Pole Magnet Adjustment & Centering Magnet Adjustment), Added step #7 to 2-6. Centering Magnet Adjustment, Updated 2-9. Defocus Adjustment (Blue) step #5 (Replaced Page 18 with Page 18) Corrected instructions for 3-2. HV Hold Down Circuit Operation Check (Replaced Page 38 with Page 38) Corrected procedure for 3-4. +B OVP Confirmation (Replaced Page 39 with Page 39)
10/2004		Removed Note from section 2-12-1. Setup For Adjustment. Note is intended for use by the factory during production, and should not be performed by service technicians. (Replaced Page 30 with Page 30) Added new Q Box Assembly PNs for all models to Exploded View 6-3. Chassis section (Replaced Page 101 with Page 101)
1/2005		Added Caution statement. (Replaced Page 5 with Page 5)

**COLOR REAR VIDEO PROJECTION**

**SONY®**

# SERVICE MANUAL

# AX1 CHASSIS

<u>MODEL NAME</u>	<u>REMOTE COMMANDER</u>	<u>DESTINATION</u>	<u>CHASSIS NO.</u>
<b>KDP-51WS550</b>	RM-Y192	US/CND	SCC-M11CA
<b>KDP-57WS550</b>	RM-Y192	US/CND	SCC-M11AA
<b>KDP-65WS550</b>	RM-Y192	US/CND	SCC-M11BA



KDP-65WS550



RM-Y192

COLOR REAR VIDEO PROJECTION

# SONY®

## TABLE OF CONTENTS

SECTION TITLE	PAGE	SECTION TITLE	PAGE
Specifications .....	4	<b>SECTION 4: CIRCUIT ADJUSTMENTS .....</b>	<b>40</b>
Warnings and Cautions .....	5	4-1. P & P Sub Contrast Adjustment (Video) (SCON) .....	40
Safety Check-Out .....	6	4-2. P & P Sub Contrast Adjustment (RF) (SCON) .....	40
Self-Diagnostic Function .....	7	4-3. P & P Sub-Hue and Sub-Color Adjustment Video (SHUE, SCOL) .....	40
<b>SECTION 1: DISASSEMBLY .....</b>	<b>10</b>	4-4. P & P Sub-Hue and Sub-Color Adjustment (RF) (SHUE, SCOL) .....	40
1-1. Rear Board Removal .....	10	4-5. Blue Offset Adjustment .....	41
1-2. Terminal Board and UD Board Removal .....	10	<b>SECTION 5: DIAGRAMS .....</b>	<b>42</b>
1-3. Chassis Assembly Removal .....	11	5-1. Circuit Boards Location .....	42
1-4. Service Position .....	11	5-2. Printed Wiring Boards and Schematic Diagrams Information .....	42
1-5. MA Board, BM Board, G2 Board, AD board, Q Box Assembly, and UA Board Removal .....	12	5-3. Block Diagrams .....	44
1-6. D Board, A Board, and DS Board Removal .....	12	5-4. Schematics and Supporting Information .....	48
1-7. High-Voltage Cable Installation and Removal .....	13	CR Board Schematic Diagram .....	48
1-8. Picture Tube Removal .....	13	CB Board Schematic Diagram .....	49
1-9. Grille, HA Board, QH Board, and HB Board Removal .....	14	CG Board Schematic Diagram .....	50
1-10. Bezzet Assembly Removal .....	14	VM Board Schematic Diagram .....	51
1-11. SR Board Removal .....	15	MA Board Schematic Diagram (1 of 3) .....	52
1-12. Mirror Cover Removal (KDP-51WS550/57WS550 Only) .....	15	MA Board Schematic Diagram (2 of 3) .....	53
<b>SECTION 2: SET-UP ADJUSTMENTS .....</b>	<b>16</b>	MA Board Schematic Diagram (3 of 3) .....	54
2-1. Screen Voltage Adjustment (G2) (Coarse Adjustment) .....	16	A Board Schematic Diagram (1 of 2) .....	56
2-2. Screen (G2) Adjustment (Fine Adjustment) .....	16	A Board Schematic Diagram (2 of 2) .....	57
2-3. Deflection Yoke Tilt Adjustment .....	16	UA Board Schematic Diagram (1 of 2) .....	60
2-4. Focus Lens Adjustment .....	17	UA Board Schematic Diagram (2 of 2) .....	61
2-5. Focus VR Adjustment .....	17	AD Board Schematic Diagram .....	64
2-6. Centering Magnet Adjustment .....	18	D Board Schematic Diagram (1 of 3) .....	66
2-7. 2-Pole Magnet Adjustment .....	18	D Board Schematic Diagram (2 of 3) .....	67
2-8. 4-Pole Magnet Adjustment .....	18	D Board Schematic Diagram (3 of 3) .....	68
2-9. Defocus Adjustment (Blue) .....	18	UD Board Schematic Diagram .....	71
2-10. Electrical Adjustments by Remote Commander .....	19	BM Board Schematic Diagram (1 of 3) .....	73
2-10-1. Method of Entering the Service Adjustment Mode ..	19	BM Board Schematic Diagram (2 of 3) .....	74
2-10-2. Memory Write Confirmation Method .....	19	BM Board Schematic Diagram (3 of 3) .....	75
2-10-3. Adjusting Buttons and Indicator .....	19	DS Board Schematic Diagram .....	77
2-11. Adjustable Service Data Lists .....	20	G2 Board Schematic Diagram .....	78
2-11-1. ID Map Table .....	29	QI Board Schematic Diagram (1 of 3) .....	80
2-12. Registration Adjustment (PJE Mode Only) .....	30	QI Board Schematic Diagram (2 of 3) .....	81
2-12-1. Setup for Adjustment .....	30	QI Board Schematic Diagram (3 of 3) .....	82
2-12-2. Main Deflection Adjustment .....	30	QM Board Schematic Diagram (1 of 5) .....	84
2-12-3. Operation Method for Projector Engine Mode .....	31	QM Board Schematic Diagram (2 of 5) .....	85
2-13. PJE Adjustment (Sub Deflection Adjustment) .....	32	QM Board Schematic Diagram (3 of 5) .....	86
2-13-1. Adjustment for NTSC Full Mode .....	33	QM Board Schematic Diagram (4 of 5) .....	87
2-13-2. Copying All Registration Data to Other Modes .....	35	QM Board Schematic Diagram (5 of 5) .....	88
2-14. Auto Registration Offsets .....	35	QT Board Schematic Diagram .....	91
2-15. Auto Registration Error Codes .....	36	HA Board Schematic Diagram .....	93
2-16. Auto Registration Diagnostics .....	37	QH Board Schematic Diagram .....	95
<b>SECTION 3: SAFETY-RELATED ADJUSTMENTS .....</b>	<b>38</b>	SR Board Schematic Diagram .....	96
D BOARD .....	38	HB Board Schematic Diagram .....	97
3-1. HV Regulation Circuit Check and Adjustment .....	38	5-5. Semiconductors .....	98
3-2. HV Hold Down Circuit Operation Check .....	38	<b>SECTION 6: EXPLODED VIEWS .....</b>	<b>99</b>
G BOARD .....	39	6-1. Cover (KDP-51WS550/57WS550 Only) .....	99
3-3. +B Max Voltage Confirmation .....	39	6-2. Cover (KDP-65WS550 Only) .....	100
3-4. +B OVP Confirmation .....	39	6-3. Chassis .....	101
		6-4. Picture Tube .....	102
		<b>SECTION 7: ELECTRICAL PARTS LIST .....</b>	<b>103</b>

## SPECIFICATIONS

**Power Requirements** 120V AC, 60Hz

**Power Consumption (W)**

**In Use (Max)** 295W  
**In Standby** Under 1 W  
**In i.LINK Standby** Under 17 W

**Inputs/Outputs DVI-HDTV**

1 terminal, 3.3V T.M.D.S., 50 ohms  
 The DVI-HDTV input terminal is compliant with the EIA-861 standard and is not intended for use with personal computers.

**Video (IN)**

4 total (1 on front panel)  
 1Vp-p, 75ohms unbalanced, sync negative

**S Video (IN)**

3 total (1 on front panel)  
 Y: 1Vp-p, 75ohms unbalanced, sync negative  
 C: 0.286Vp-p (Burst signal), 75ohms

**Control S (IN/OUT)**

1 total

**Audio (IN)**

7 total (1 on front panel)  
 500 mVrms (100% modulation)  
 Impedance:47 kilohm

**Component Video Input**

2 ( Y,P<sub>B</sub>,P<sub>R</sub>)  
 Y: 1.0 Vp-p, 75 ohms unbalanced, sync negative;  
 P<sub>B</sub>: 0.7 Vp-p, 75 ohms;  
 P<sub>R</sub>: 0.7 Vp-p, 75 ohms

**Digital Audio Optical Output PCM/Dolby Digital**

1 total Optical Rectangular

**i.LINK**

3 total (1 on front panel)  
 4-pin S400 i.LINK terminal

**Variable/Fixed Audio (OUT)**

More than 408 m Vrms at the maximum volume setting (Variable)  
 More than 408 m Vrms (Fixed) Impedance (output):2 kilohms

	KDP-51WS550	KDP-57WS550	KDP-65WS550
<b>Speaker Output (W)</b>	20W x 2		
<b>Dimensions (W x H x D)</b>			
mm	1194 x 1350 x 650 mm	1362 x 1377 x 690 mm	1542 x 1507 x 735 mm
in	47 x 53 <sup>1/8</sup> x 25 <sup>5/8</sup> in	52 <sup>1/4</sup> x 54 <sup>3/16</sup> x 27 <sup>1/8</sup> in	60 <sup>3/4</sup> x 59 <sup>1/4</sup> x 28 <sup>15/16</sup> in
<b>Mass</b>			
kg	79.3 kg	87 kg	139.5 kg
lbs	174.5 lbs	191.5 lbs	307 lbs

**Projection System**

3 picture tubes, 3 lenses, horizontal in-line system

**Picture Tube**

7-inch high-brightness monochrome tubes (6.3 raster size), with optical coupling and liquid cooling system.

**Projection Lenses**

High performance, large diameter hybrid lens F1.1

**Antenna**

75 ohm external terminal for VHF/UHF

**Television System**

NTSC, American TV Standard

**Channel Coverage**

VHF: 2-13/UHF: 14-69/DTV: 1-999/CATV: 1-125

**Screen Size (measured diagonally)**

51 inches (KDP-51WS550)  
 57 inches (KDP-57WS550)  
 65 inches (KDP-65WS550)

**Supplied Accessories**

Remote Control RM-Y192  
 Batteries (2) size AA (R6)

**Optional Accessories**

A/V Cable (VMC-810/820/830 HG)  
 Audio Cable (RKC-515HG)  
 Component Video Cable (VMC-10/30 HG)  
 Control S Cable (RK-G69HG)  
 i.LINK cables: VMC-IL4415 (4-pin to 4 pin, 1.5 meters);  
 VMC-IL4435 (4-pin, 3.5 meters)

## WARNINGS AND CAUTIONS

### CAUTION

 These servicing instructions are for use by qualified service personnel only. To reduce the risk of electric shock, do not perform any servicing other than that contained in the operating instructions unless you are qualified to do so.

### WARNING!!

An isolation transformer should be used during any service to avoid possible shock hazard, because of live chassis. The chassis of this receiver is directly connected to the ac power line.

### SAFETY-RELATED COMPONENT WARNING!!

Components identified by shading and  mark on the schematic diagrams, exploded views, and in the parts list are critical for safe operation. Replace these components with Sony parts whose part numbers appear as shown in this manual or in supplements published by Sony. Circuit adjustments that are critical for safe operation are identified in this manual. Follow these procedures whenever critical components are replaced or improper operation is suspected.

---

### ATTENTION!!

 Ces instructions de service sont à l'usage du personnel de service qualifié seulement. Pour prévenir le risque de choc électrique, ne pas faire l'entretien autre que celui contenu dans le Mode d'emploi à moins que vous soyez qualifié faire ainsi.

Afin d'éviter tout risque d'électrocution provenant d'un châssis sous tension, un transformateur d'isolement doit être utilisé lors de tout dépannage. Le châssis de ce récepteur est directement raccordé à l'alimentation du secteur.

### ATTENTION AUX COMPOSANTS RELATIFS A LA SECURITE!!

Les composants identifiés par une trame et par une marque  sur les schémas de principe, les vues explosées et les listes de pièces sont d'une importance critique pour la sécurité du fonctionnement. Ne les remplacer que par des composants Sony dont le numéro de pièce est indiqué dans le présent manuel ou dans des suppléments publiés par Sony. Les réglages de circuit dont l'importance est critique pour la sécurité du fonctionnement sont identifiés dans le présent manuel. Suivre ces procédures lors de chaque remplacement de composants critiques, ou lorsqu'un mauvais fonctionnement suspecte.

## SAFETY CHECK-OUT

After correcting the original service problem, perform the following safety checks before releasing the set to the customer:

1. Check the area of your repair for unsoldered or poorly soldered connections. Check the entire board surface for solder splashes and bridges.
2. Check the interboard wiring to ensure that no wires are "pinched" or touching high-wattage resistors.
3. Check that all control knobs, shields, covers, ground straps, and mounting hardware have been replaced. Be absolutely certain that you have replaced all the insulators.
4. Look for unauthorized replacement parts, particularly transistors, that were installed during a previous repair. Point them out to the customer and recommend their replacement.
5. Look for parts which, though functioning, show obvious signs of deterioration. Point them out to the customer and recommend their replacement.
6. Check the line cords for cracks and abrasion. Recommend the replacement of any such line cord to the customer.
7. Check the B+ and HV to see if they are specified values. Make sure your instruments are accurate; be suspicious of your HV meter if sets always have low HV.
8. Check the antenna terminals, metal trim, "metallized" knobs, screws, and all other exposed metal parts for AC leakage. Check leakage as described below.

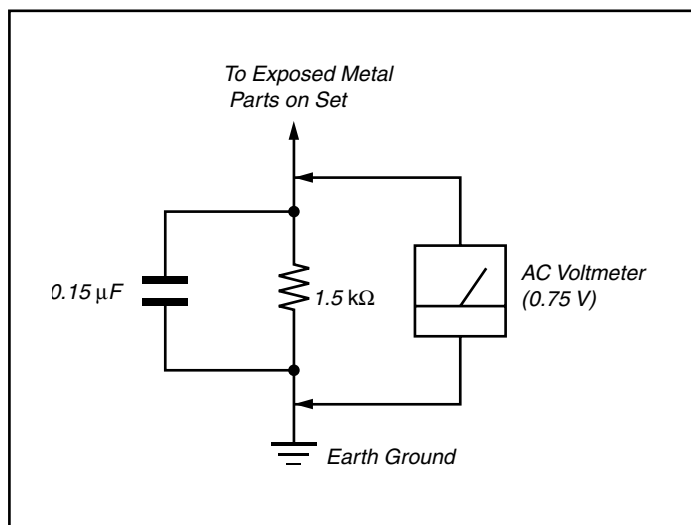

Figure A. Using an AC voltmeter to check AC leakage.

### Leakage Test

The AC leakage from any exposed metal part to earth ground and from all exposed metal parts to any exposed metal part having a return to chassis, must not exceed 0.5 mA (500 microamperes). Leakage current can be measured by any one of three methods.

1. A commercial leakage tester, such as the Simpson 229 or RCA WT-540A. Follow the manufacturers' instructions to use these instructions.
2. A battery-operated AC milliammeter. The Data Precision 245 digital multimeter is suitable for this job.
3. Measuring the voltage drop across a resistor by means of a VOM or battery-operated AC voltmeter. The "limit" indication is 0.75 V, so analog meters must have an accurate low voltage scale. The Simpson's 250 and Sanwa SH-63TRD are examples of passive VOMs that are suitable. Nearly all battery-operated digital multimeters that have a 2 VAC range are suitable (see Figure A).

### How to Find a Good Earth Ground

A cold-water pipe is a guaranteed earth ground; the cover-plate retaining screw on most AC outlet boxes is also at earth ground. If the retaining screw is to be used as your earth ground, verify that it is at ground by measuring the resistance between it and a cold-water pipe with an ohmmeter. The reading should be zero ohms.

If a cold-water pipe is not accessible, connect a 60- to 100-watt trouble-light (not a neon lamp) between the hot side of the receptacle and the retaining screw. Try both slots, if necessary, to locate the hot side on the line; the lamp should light at normal brilliance if the screw is at ground potential (see Figure B).

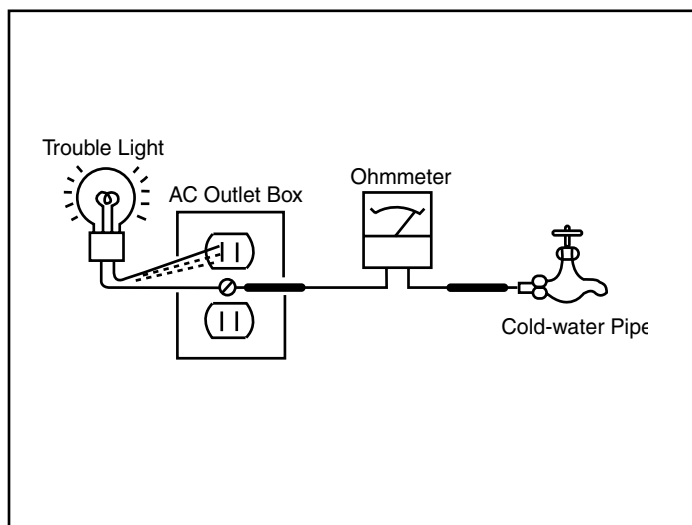

Figure B. Checking for earth ground.

## SELF-DIAGNOSTIC FUNCTION



The units in this manual contain a self-diagnostic function. If an error occurs, the STANDBY/TIMER LED will automatically begin to flash. The number of times the LED flashes translates to a probable source of the problem. A definition of the STANDBY/TIMER LED flash indicators is listed in the instruction manual for the user's knowledge and reference. If an error symptom cannot be reproduced, the Remote Commander can be used to review the failure occurrence data stored in memory to reveal past problems and how often these problems occur.

### Diagnostic Test Indicators

When an error occurs, the STANDBY/TIMER LED will flash a set number of times to indicate the possible cause of the problem. If there is more than one error, the LED will identify the first of the problem areas.

Results for all of the following diagnostic items are displayed on screen. If the screen displays a "0", no error has occurred.

Diagnostic Item	No. of times STANDBY / TIMER lamp flashes	Display Result	Probable Cause Location	Detected Symptoms
Power does not turn on	Does not light	_____	<ul style="list-style-type: none"> <li>Power cord is not plugged in.</li> <li>Fuse is burned out (F6000). (A Board)</li> </ul>	<ul style="list-style-type: none"> <li>Power does not come on.</li> <li>No power is supplied to the TV.</li> <li>AC Power supply is faulty.</li> </ul>
+B Overcurrent (OCP)*	2 times	2:0 or 2:1	<ul style="list-style-type: none"> <li>H.OUT (Q5001) is shorted. (D Board)</li> <li>+B PWM (Q5201) is shorted. (D Board)</li> </ul>	<ul style="list-style-type: none"> <li>Power does not come on.</li> <li>Load on power line shorted.</li> </ul>
Low +B Overvoltage (OVP)	3 times	3:0 or 3:1	<ul style="list-style-type: none"> <li>IC6503 is faulty. (D Board)</li> </ul>	<ul style="list-style-type: none"> <li>Has entered standby mode.</li> </ul>
Vertical Deflection Stopped	4 times	4:0 or 4:1	<ul style="list-style-type: none"> <li>15V is not supplied. (D Board)</li> <li>IC5101 is faulty. (D Board)</li> </ul>	<ul style="list-style-type: none"> <li>Has entered standby mode after Horizontal raster.</li> <li>Vertical deflection pulse is stopped.</li> <li>Power line is shorted or power supply is stopped.</li> </ul>
White Balance Failure (not balanced)	5 times	5:0 or 5:1	<ul style="list-style-type: none"> <li>Video OUT (IC9101, IC9201, IC9301) is faulty. (CR, CG, CB Board)</li> <li>CRT drive (IC0401) is faulty. (MA Board)</li> <li>G2 is improperly adjusted.**</li> </ul>	<ul style="list-style-type: none"> <li>No raster is generated.</li> <li>CRT cathode current detection reference pulse output is small.</li> </ul>
LOW +B OCP/OVP (overcurrent/overvoltage)***	6 times	6:0 or 6:1	<ul style="list-style-type: none"> <li>+5 line is overloaded. (A, BM, MA Boards)</li> <li>+5 line is shorted. (A, BM, MA Boards)</li> <li>IC6201 is faulty. (A Board)</li> </ul>	<ul style="list-style-type: none"> <li>No picture</li> </ul>
Horizontal Deflection Stopped	7 times	7:0 or 7:1	<ul style="list-style-type: none"> <li>Q5006 is broken (D Board)</li> <li>IC0401 is faulty (MA Board)</li> </ul>	<ul style="list-style-type: none"> <li>No picture</li> </ul>
Audio Protection	8 times	8:0 or 8:1	<ul style="list-style-type: none"> <li>+ or - 22V audio supply is not present—Check PS2001 &amp; PS2000</li> <li>Audio AMP is damaged IC2000 on A Board</li> </ul>	<ul style="list-style-type: none"> <li>No picture</li> </ul>
Zero Crossing Detector	9 times	9:0 or 9:1	<ul style="list-style-type: none"> <li>D6166 or D6114 is open (A Board)</li> </ul>	<ul style="list-style-type: none"> <li>No picture</li> </ul>
HV Protection	10 times	10:0 or 10:1	<ul style="list-style-type: none"> <li>Q8014 or Q8013 have shorted replace along with R8051 on D Board</li> <li>IC8005 is damaged (D Board)</li> </ul>	<ul style="list-style-type: none"> <li>No picture</li> </ul>

\* If a +B overcurrent is detected, stoppage of the vertical deflection is detected simultaneously. The symptom that is diagnosed first by the microcontroller is displayed on the screen.

\*\* Refer to Screen (G2) Adjustment (Fine Adjustments) in Section 2 of this manual.

\*\*\* If STANDBY/STEREO LED flashes six (6) times, unplug the unit and wait 10 seconds before performing the adjustment.

**Display of Standby/Timer LED Flash Count**

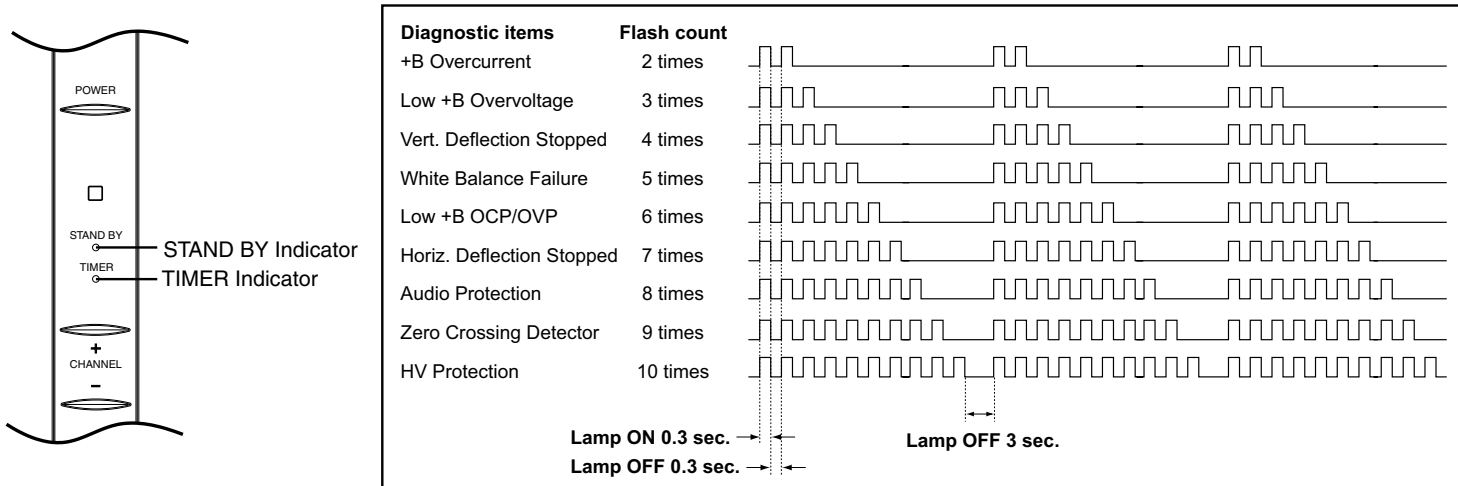

**Release of TIMER STAND BY indicator blinking**

The TIMER/STANDBY indicator blinking display is released by turning OFF the power switch on the TV main unit or removing the plug from the power.

**Self-Diagnosis Screen Displays**

In cases of malfunctions where it is not possible to determine the symptom such as when the power goes off occasionally or when the screen disappears occasionally, there is a screen display on whether the malfunction occurred or not in the past (and whether the detection circuit operated or not) in order to allow confirmation.

**Screen Display Method**

Quickly press the remote command button in the following order from the standby state.

Display → Channel 5 → Sound Volume\* → Power ON

SELF DIAGNOSIS	
2: +B OCP	0
3: +B OVP	0
4: VSTOP	0
5: AKB	1
6: LOWB	0
7: H-STOP	0
8: AUDIO	0
9: ZCD	0
10: HV PROT	0
101: WDT	24

\*Note that this differs from entering the service mode (sound volume +)

Numeral "0" means that no fault was detected.  
 Numerical "1" means a fault was detected one time only.

**Self-Diagnosis Screen Display**

The results display is not automatically cleared. In case of repairs and after repairs, check the self-diagnosis screen and be sure to return the results display to "0".

If the results display is not returned to "0" it will not be possible to judge a new malfunction after completing repairs.

**Method of Clearing Results Display**

1. Power off (Set to the stand by mode.)
2. Display → Channel 5 → Sound Volume + → Power ON (Service Mode)
3. Channel 8 → ENTER (Test reset = Factory preset condition)

**Method of Ending Self Diagnosis Screen**

When ending the self-diagnosis screen completely, turn the power switch OFF on the remote commander or the main unit.



**Self-Diagnosis Function Operation**

**+B overcurrent (OCP)**

Occurs when excessive current flows through R6812. The increase in voltage across Q6803 causes it to turn on which sends a high signal to the micro.

**+B overvoltage (OVP)**

IC6801 detects +B OVP condition and turns on Q6802. This sends a high signal to the micro and also shuts down the AC relay.

**V-STOP**

Occurs when an absence of the vertical deflection pulse is detected by pin 56 of IC0401 (MA Board). Power supply will shut down when waveform interval exceeds 2 seconds.

**White Balance Failure**

If the RGB levels\* do not balance within 2 seconds after the power is turned on, this error will be detected by IC0401. TV will stay on, but there will be no picture.

\*(Refers to the RGB levels of the AKB detection Ref pulse that detects 1K).

**Low B OCP/OVP**

Occurs when set 5V is out.

**Horizontal Deflection Stopped**

Occurs when either:

- 1) a +B overcurrent is detected (Q6803), or
- 2) IC0401 (MA Board) is damaged.

**Self-Diagnosis Block Diagram**

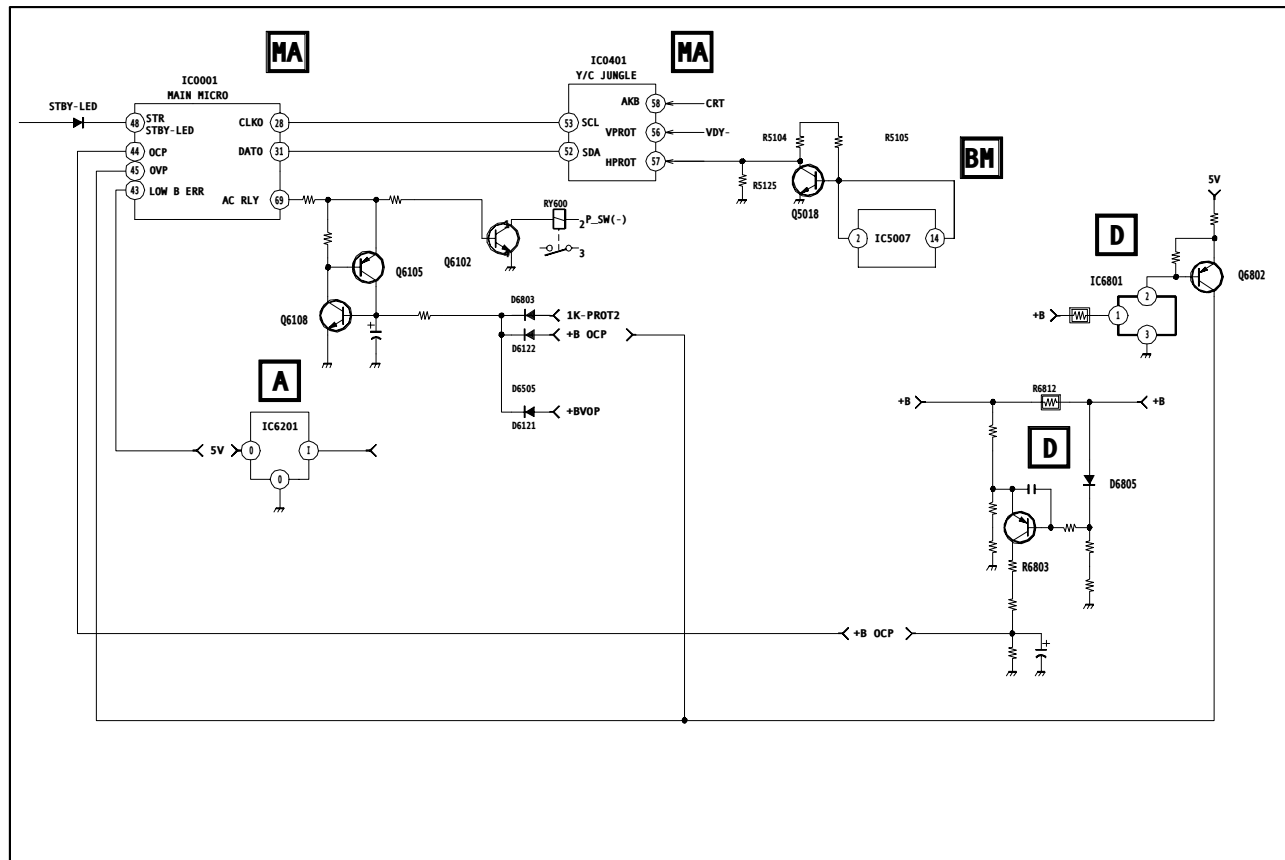

# SECTION 1: DISASSEMBLY

## 1-1. REAR BOARD REMOVAL

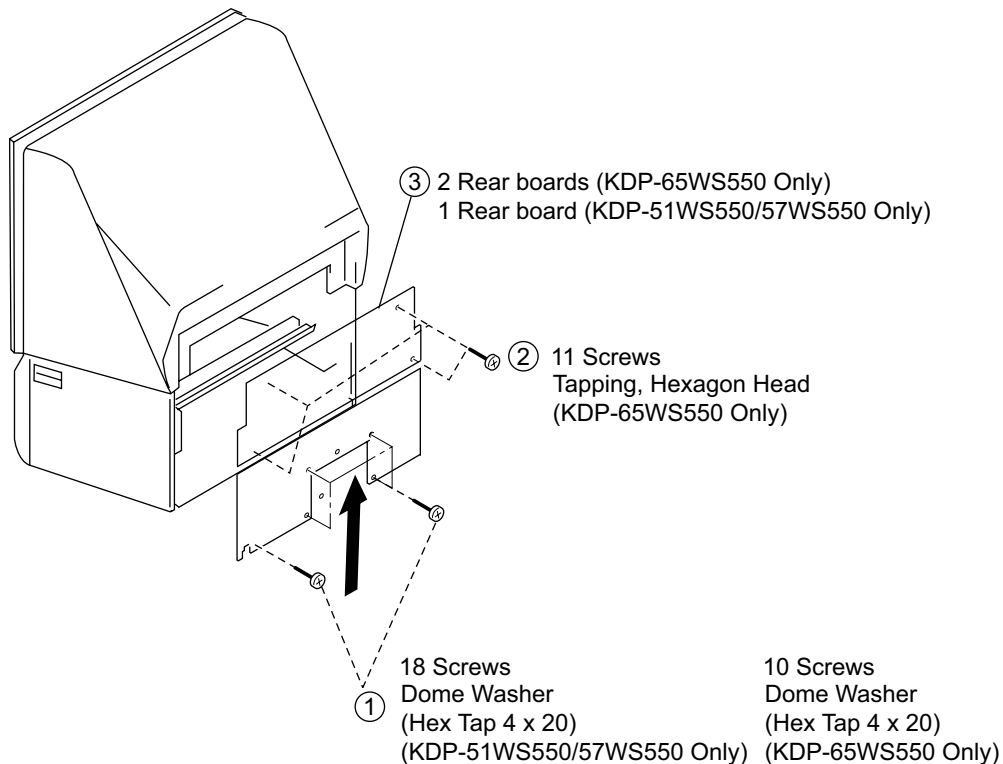

## 1-2. TERMINAL BOARD AND UD BOARD REMOVAL

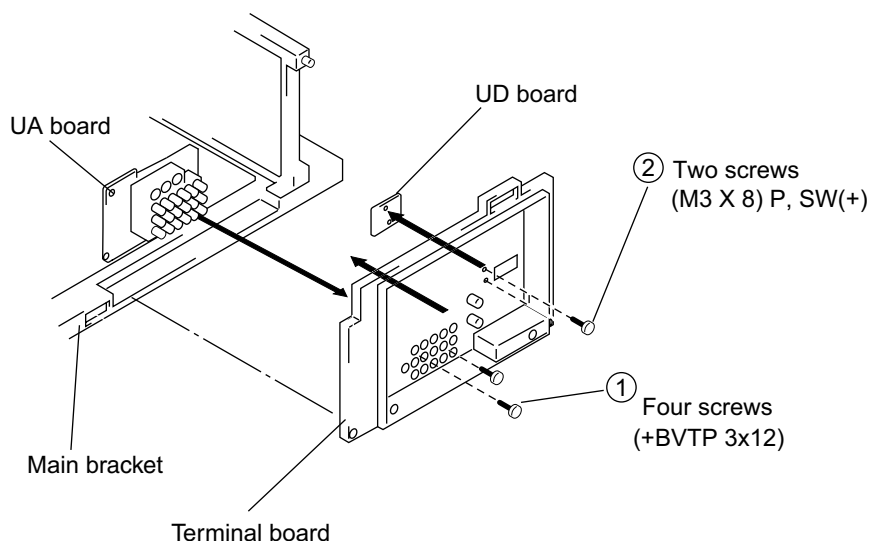

### 1-3. CHASSIS ASSEMBLY REMOVAL

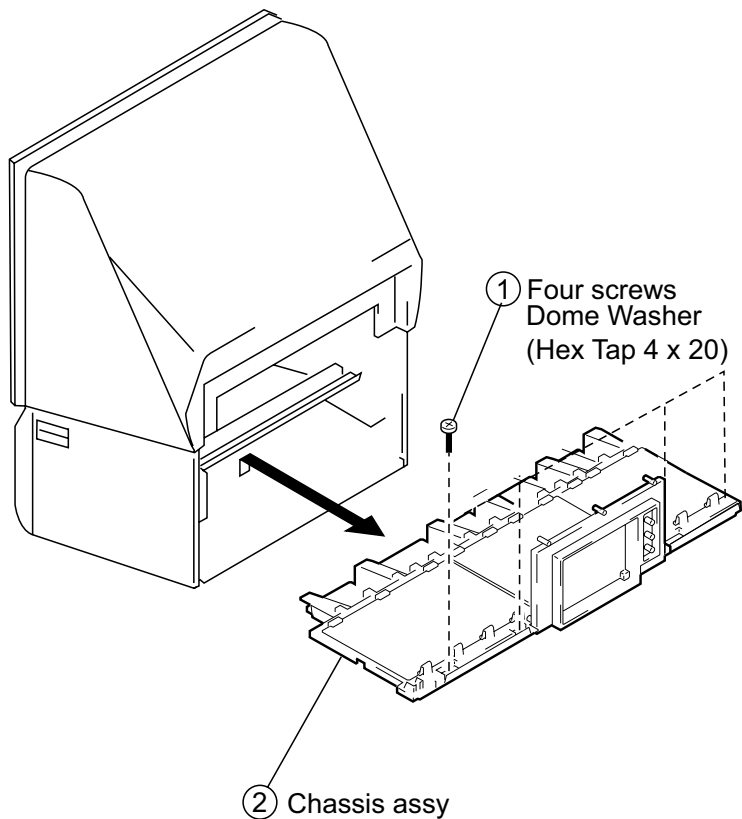

### 1-4. SERVICE POSITION

- ① Free wiring from purse locks.  
NOTE: Observe wire dress and return to original condition.
- ② Covers  
Remove covers from chassis assembly with pliers when checking printed circuit boards. After checking, turn the covers over and re-secure them with the screws.

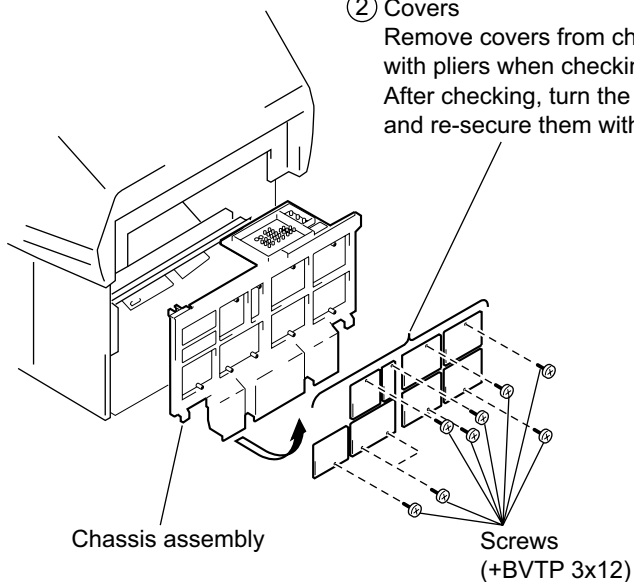

### 1-5. MA BOARD, BM BOARD, G2 BOARD, AD BOARD, Q BOX ASSEMBLY, AND UA BOARD REMOVAL

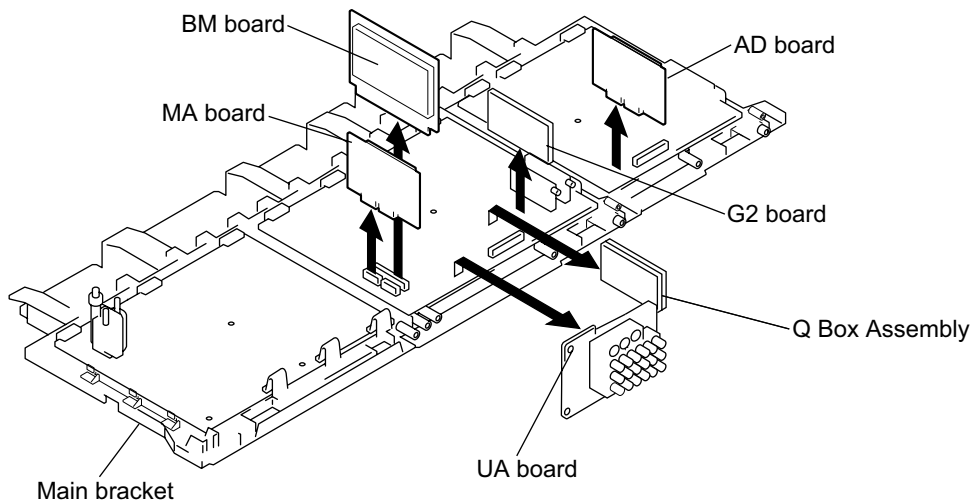

### 1-6. D BOARD, A BOARD, AND DS BOARD REMOVAL

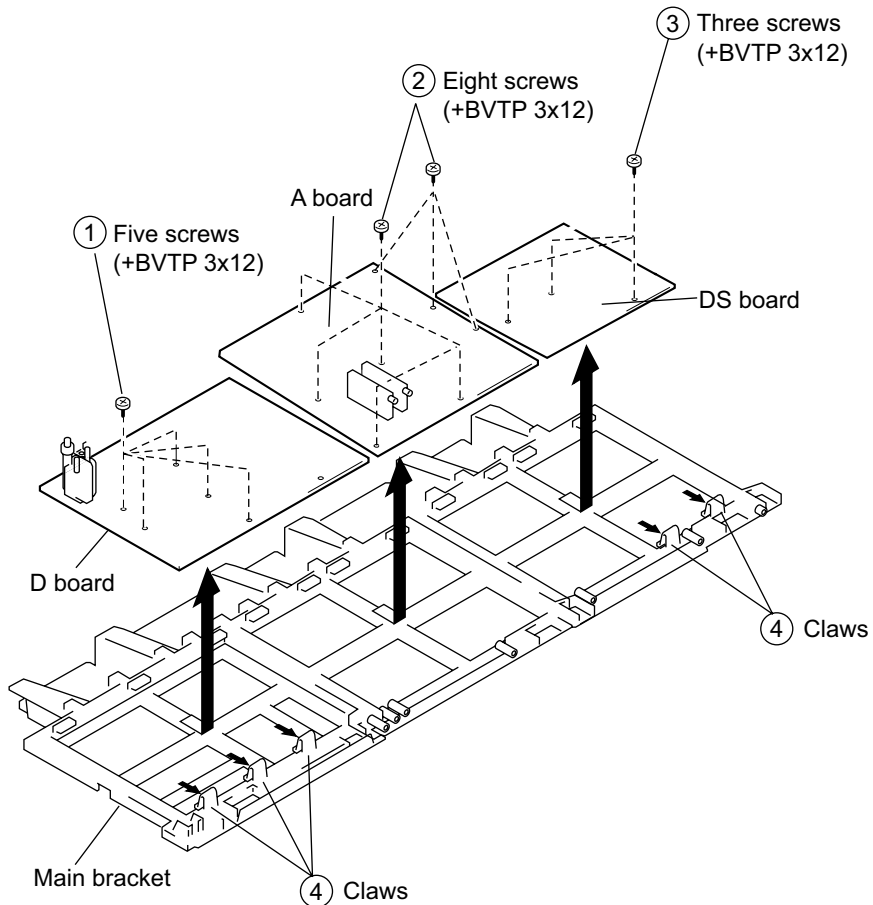

### 1-7. HIGH-VOLTAGE CABLE INSTALLATION AND REMOVAL

(1) Removal

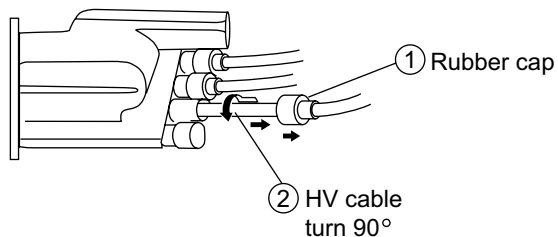

(2) Installation

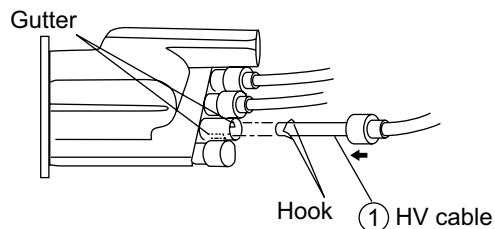

### 1-8. PICTURE TUBE REMOVAL

**CAUTION:** Removing the arrow-marked screws is strictly prohibited. If removed, it may cause liquid to spill.

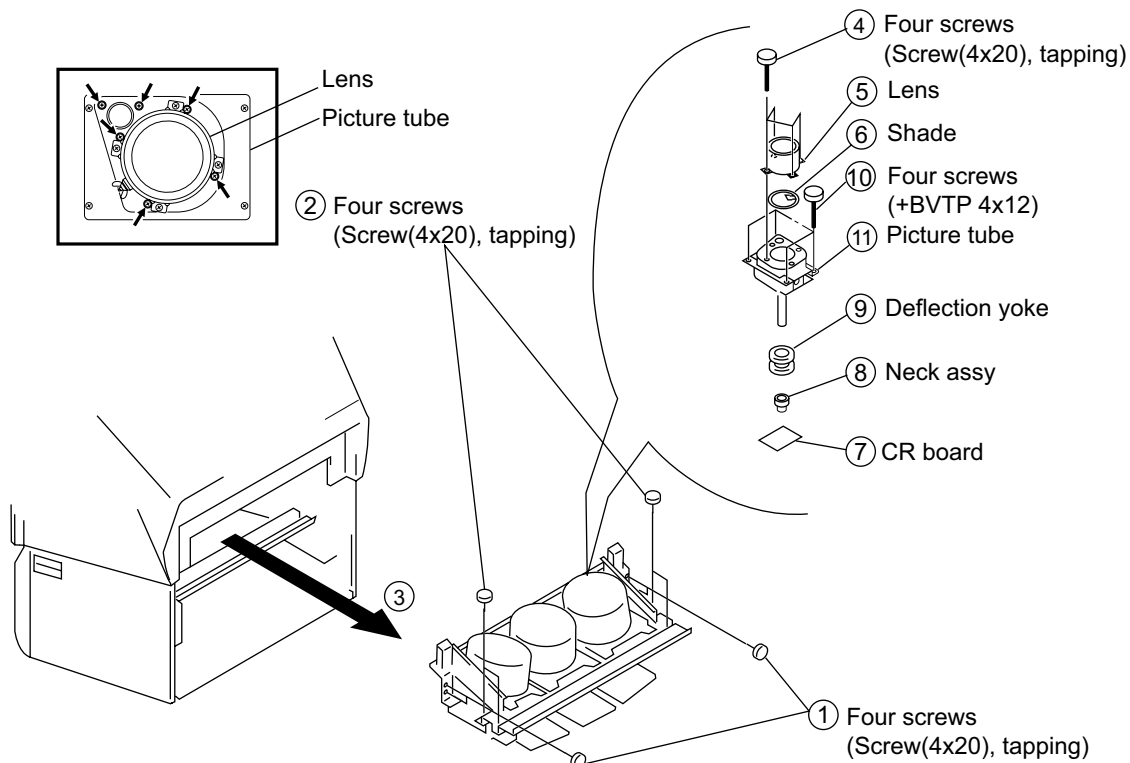

### 1-9. GRILLE, HA BOARD, QH BOARD, AND HB BOARD REMOVAL

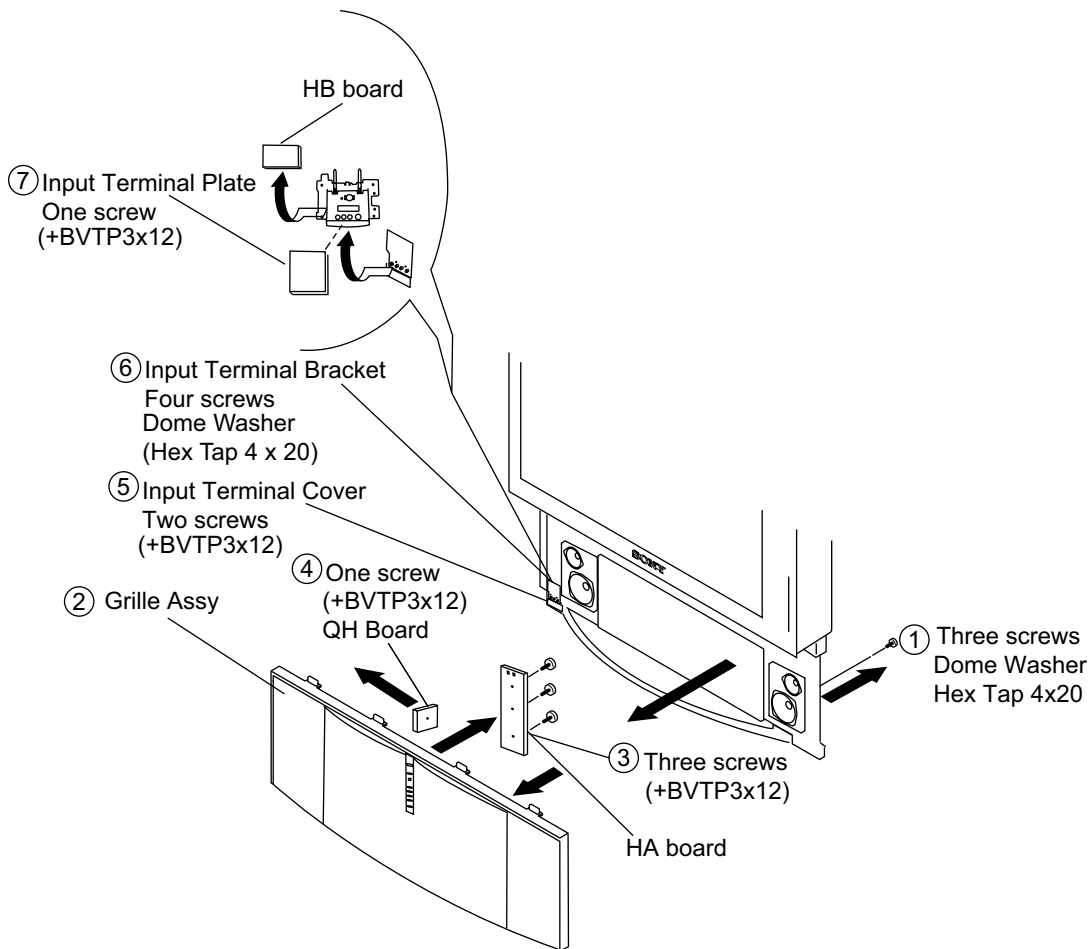

### 1-10. BEZNET ASSEMBLY REMOVAL

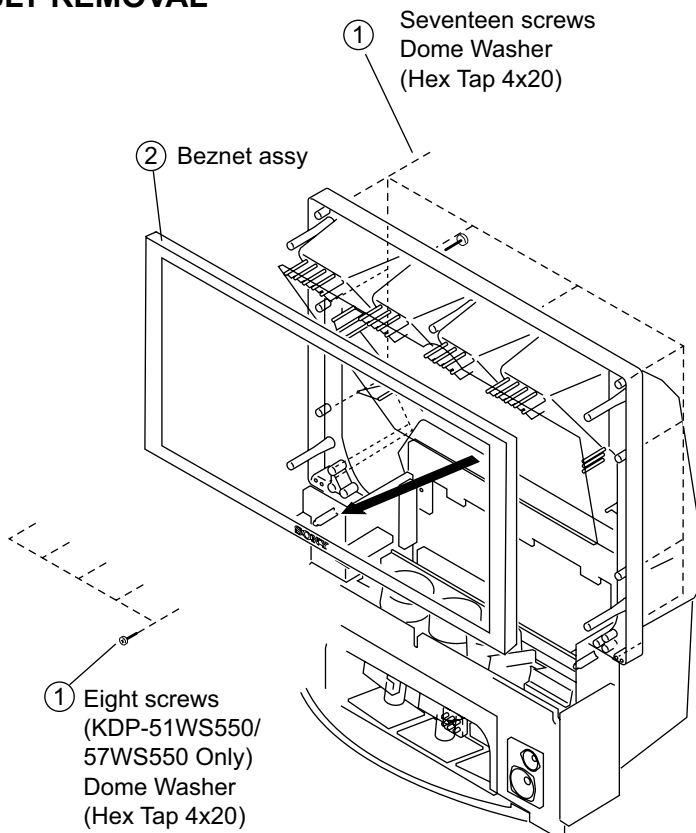

### 1-11.SR BOARD REMOVAL

The Screen Holder does not need to be removed in order to remove the SR boards.

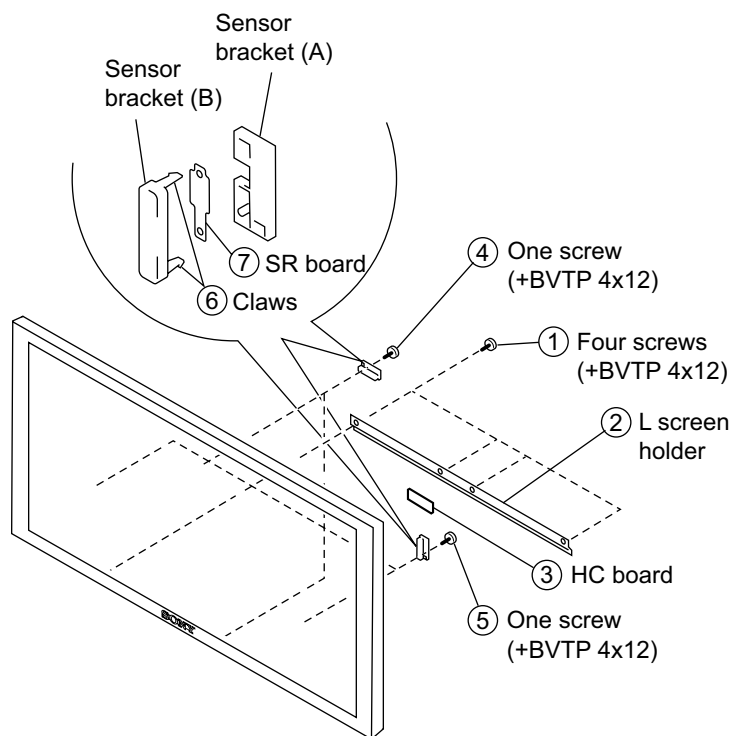

### 1-12.MIRROR COVER REMOVAL (KDP-51WS550/57WS550 ONLY)

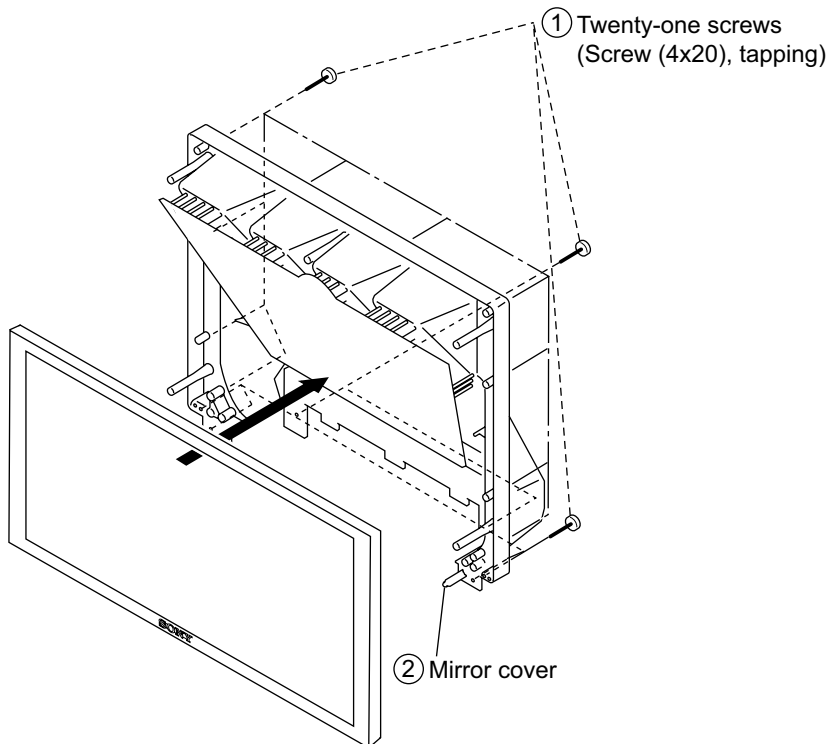

## SECTION 2: SET-UP ADJUSTMENTS

### 2-1. SCREEN VOLTAGE ADJUSTMENT (G2) (COARSE ADJUSTMENT)

1. Receive the Monoscope signal.
2. Set BRIGHTNESS to 50% and PICTURE to minimum.
3. Turn the red VR on the focus block all the way to the left and then gradually turn it to the right until the retrace line is barely visible.
4. Gradually turn the control to the left until the retrace line disappears.

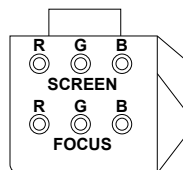

FOCUS Block

### 2-2. SCREEN (G2) ADJUSTMENT (FINE ADJUSTMENT)

If the jig described below is available, it is recommended that the G2 Fine Mode Adjustment be performed to set the screen controls to their optimal condition. If desired, you can build the jig illustrated below, using 3-watt resistors. Please note that if the proper voltage is not obtained with the listed resistor's values, then increase or decrease one of the values in the resistor network to obtain the correct voltage.

1. Select VIDEO-1 mode no signal applied (the screen must be black).
2. Connect the G2 JIG.
3. SW on JIG.
4. Connect an oscilloscope to the TP9101(KR), TP9201(KG) and TP9301(KB) of CR board, CG board, and CB board.
5. Adjust red, green, and blue screen voltage to  $177.5 \pm 0.5V$  with screen VR on the focus block.

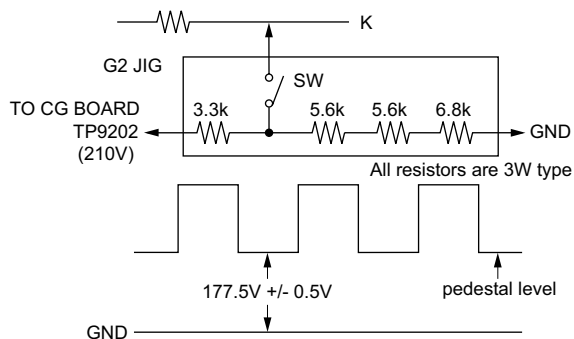

### 2-3. DEFLECTION YOKE TILT ADJUSTMENT

1. Connect the color bar generator monoscope pattern to Video 1 input.
2. Cover the red and blue CRT lenses with lens caps to allow only green to show (or use the method shown in the note below for turning off the CRTs individually without using lens caps).
3. Loosen the CRT's deflection yoke set screw and align the tilt of the deflection yoke so that the horizontal bars at the center of the cross-hatch pattern are parallel to the top and bottom edges of the screen.
4. After aligning the deflection yoke fasten it securely to the funnel-shaped portion (neck) of the CRT.
5. Cover the green and blue CRT lenses with lens caps to allow only green to show (or use the method shown in the note below for turning off the CRTs individually without using lens caps), then repeat steps 3 and 4 for the red CRT.  
Cover the green and red CRT lenses with lens caps to allow only green to show (or use the method shown in the note below for turning off the CRTs individually without using lens caps), then repeat steps 3 and 4 for the blue CRT.

**Note:** If lens caps are unavailable, you can cut off the unnecessary color beams by controlling the service mode MCP-RON, GON, BON.

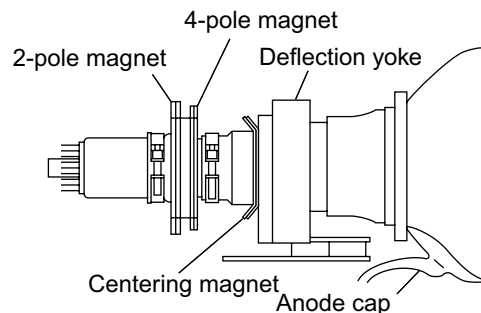



## 2-4. FOCUS LENS ADJUSTMENT

In this adjustment, use the remote commander while in service mode. For details on the usage of the service mode and the remote commander, please refer to section

### 2-10. ELECTRICAL ADJUSTMENTS BY REMOTE COMMANDER.

1. Loosen the lens screw.
2. Cover the red and blue CRT lenses with lens caps to allow only green to show (or use the method shown in the note below for turning off the CRTs individually without using lens caps).
3. Turn the green lens to adjust to the optimum focus point with the crosshatch signal.
4. Tighten the lens screw.
5. Cover the green and blue CRT lenses with the lens caps to allow only red to show (or use the method shown in the note below for turning off the CRTs individually without using lens caps).
6. Turn the red lens to adjust to the optimum focus point with the crosshatch signal.
7. Tighten the lens screw.
8. Cover the green and red CRT lenses with the lens caps to allow only blue to show (or use the method shown in the note below for turning off the CRTs individually without using lens caps).
9. Turn the blue lens to adjust to the optimum focus point with the crosshatch signal.
10. Tighten the lens screw.
11. After adjusting the items:  
 2-5. FOCUS VR ADJUSTMENT,  
 2-7. 2-POLE MAGNET ADJUSTMENT,  
 2-8. 4-POLE MAGNET ADJUSTMENT,  
 reconfirm the optimum focus point and adjust again if necessary.

\* In PJE mode, every time 6 is pressed, the test signal changes to:  
 "crosshatch+video signal" → "crosshatch+borderline (black)" →  
 "crosshatch (black)" → "dots (black)" → "all white" → off

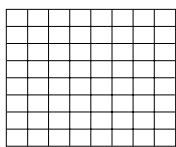

Test Signal

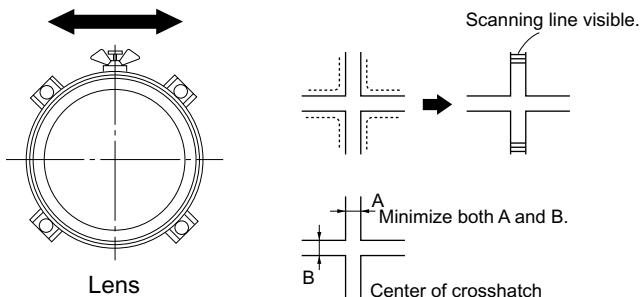

**Note:** If lens caps are unavailable, you can cut off the unnecessary color beams by controlling the service mode MCP-RON, GON, BON.

## 2-5. FOCUS VR ADJUSTMENT

1. Set generator to crosshatch.
2. Cover the red and blue CRT lenses with lens caps to allow only green to show (or use the method shown in the note below for turning off the CRTs individually without using lens caps).
3. Turn the green focus VR on the focus block to adjust to the optimum focus point with the crosshatch signal.
4. Cover the green and blue picture lenses with lens caps to allow only red to show (or use the method shown in the note below for turning off the CRTs individually without using lens caps).
5. Turn the red focus VR on the focus block to adjust to the optimum focus point with the crosshatch signal.
6. Cover the green and red picture lenses with lens caps to allow only blue to show (or use the method shown in the note below for turning off the CRTs individually without using lens caps).
7. Turn the blue focus VR on the focus block to adjust to the optimum focus point with the crosshatch signal.
8. After adjusting the items:  
 2-4. FOCUS LENS ADJUSTMENT,  
 2-7. 2-POLE MAGNET ADJUSTMENT,  
 2-8. 4-POLE MAGNET ADJUSTMENT,  
 reconfirm the optimum focus point and adjust again if necessary.

**Note:** If lens caps are unavailable, you can cut off the unnecessary color beams by controlling the service mode MCP-RON, GON, BON.

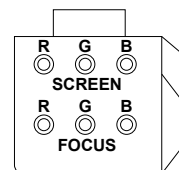

FOCUS Block

## 2-6. CENTERING MAGNET ADJUSTMENT

1. Set the mode to PRO.
2. Receive the monoscope signal.
3. Cover the red and blue CRT lenses with lens caps to allow only green to show (or use the method shown in the note below for turning off the CRTs individually without using lens caps).
4. Adjust the green CRT's centering magnet to put the center of the monoscope signal to the center of the screen.
5. Repeat steps 1 through 4 for the red CRT except now you will cover the green and blue CRT lenses with lens caps to allow only red to show (or use the method shown in the note below for turning off the CRTs individually without using lens caps) and you will adjust the red centering magnet.
6. Repeat steps 1 through 4 for the blue CRT except now you will cover the red and green CRT lenses with lens caps to allow only blue to show (or use the method shown in the note below for turning off the CRTs individually without using lens caps) and you will adjust the blue centering magnet.
7. After 2-Pole and 4-Pole adjustment, entering magnet adjustment needs to be confirmed. If centering magnet is re-adjusted, then 2-Pole magnet will need to be confirmed.

**Note:** If lens caps are unavailable, you can cut off the unnecessary color beams by controlling the service mode MCP-RON, GON, BON.

## 2-7. 2-POLE MAGNET ADJUSTMENT

1. Set the mode to PRO and picture to MAX.
2. Receive the 100IRE 1080i Dot signal.
3. Cover the red and blue CRT lenses with lens caps to allow only green to show (or use the method shown in the note below for turning off the CRTs individually without using lens caps).
4. Turn the focus VR on the focus block to the left (counter clockwise) and set it to overfocus to enlarge the spot.
5. Adjust the CRT's 2-pole magnet so that the small bright spot is in the center.
6. Align the focus VR on the focus block and set it for the best focus.
7. Repeat steps 1 through 6 for the red CRT covering the green and blue CRT lenses with lens caps to allow only red to show (or use the method shown in the note below for turning off the CRTs individually without using lens caps) and you will adjust the red focus control on the focus block.
8. Repeat steps 1 through 6 for the blue CRT covering the red and green CRT lenses with lens caps to allow only blue to show (or use the method shown in the note below for turning off the CRTs individually without using lens caps) and you will adjust the blue focus control on the focus block.

**Note:** If lens caps are unavailable, you can cut off the unnecessary color beams by controlling the service mode MCP-RON, GON, BON.

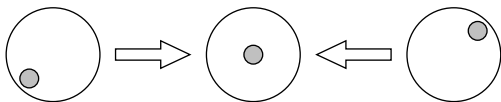

## 2-8. 4-POLE MAGNET ADJUSTMENT

1. Set the mode to VIVID and WIDE mode = Zoom, VM:Off.
2. Receive the 100IRE 1080i Dot signal.
3. Cover the red and blue CRT lenses with lens caps to allow only green to show (or use the method shown in the note below for turning off the CRTs individually without using lens caps).
4. Turn the (green) focus VR on the focus block to the right (clockwise) and set it to under-focus to reduce the spot.
5. Adjust the 4-pole magnet so that the small spot in the center of the screen becomes round for green and red.
6. Adjust the blue spot to an oval shape X:Y=1:1
7. Repeat steps 1 through 6 for the red CRT except now you will cover the green and blue CRT lenses with lens caps to allow only red to show (or use the method shown in the note below for turning off the CRTs individually without using lens caps) and you will adjust the red focus control on the focus block.
8. Repeat steps 1 through 6 for the blue CRT except now you will cover the red and green CRT lenses with lens caps to allow only blue to show (or use the method shown in the note below for turning off the CRTs individually without using lens caps) and you will adjust the blue focus control on the focus block.

**Note:** If lens caps are unavailable, you can cut off the unnecessary color beams by controlling the service mode MCP-RON, GON, BON.

Use the center dot

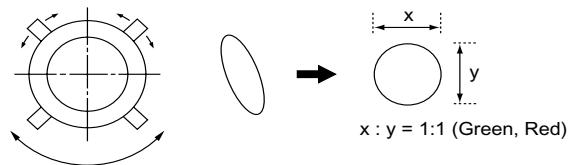

## 2-9. DEFOCUS ADJUSTMENT (BLUE)

**Note:** Adjust the blue dot to be slightly larger than red and green dots. This adjustment provides a more pleasing picture to the customer.

1. Set the mode to PRO, PICTURE : Max, COLOR TEMP : Cool.
2. Receive the 100IRE 1080i Dot signal.
3. Cover the red and green CRT lenses with lens caps to allow only blue to show (or use the method shown in the note below for turning off the CRTs individually without using lens caps).
4. Turn the blue focus VR on the focus block to the right (clockwise) until blue spot is in focus.
5. Change mode to VIVID to confirm Flare level is minimal using cross hatch signal.
6. Set the generator to an all white signal and check uniformity.

**Note:** If lens caps are unavailable, you can cut off the unnecessary color beams by controlling the service mode MCP-RON, GON, BON.

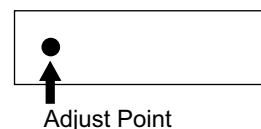

## 2-10.ELECTRICAL ADJUSTMENTS BY REMOTE COMMANDER

All of the circuit adjustments can be made by using the remote commander (RM-Y192).

**Note:** The following test equipment is required:

1. Pattern Generator (with component outputs)
2. Frequency counter
3. Digital multimeter
4. Audio oscillator

### 2-10-1.METHOD OF ENTERING THE SERVICE ADJUSTMENT MODE

#### SERVICE MODE PROCEDURE

1. TV must be in Standby mode. (Power off)
2. Press "DISPLAY", "5", "VOL +", then "POWER" on the remote commander.  
(Press each button within 1 second of pressing the previous button.)

#### SERVICE MODE ADJUSTMENT

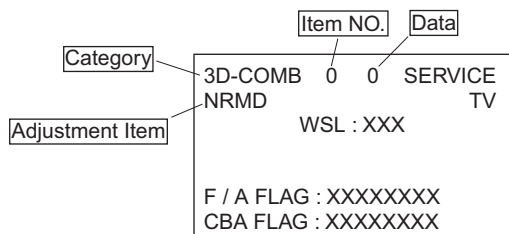

3. The screen displays the item being adjusted within that category.
4. Press 1 or 4 on the remote commander to select the adjustment item
5. Press 3 or 6 on the remote commander to change the data
6. Press 2 or 5 on the remote commander to select the adjustment category

Every time you press 2 (Category up), service mode changes in the order shown below:

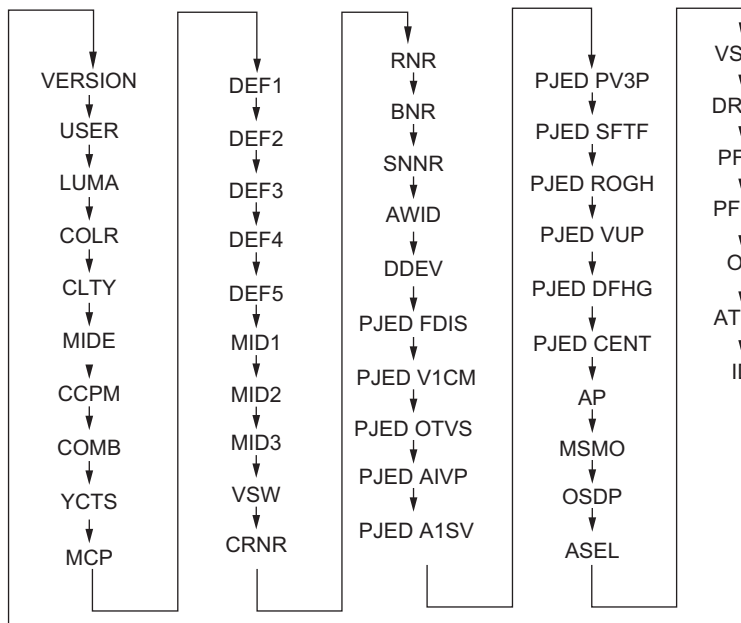

7. If you want to go back to the most recently saved value, press "0" then "ENTER" to read the memory.
8. Press "MUTING" then "ENTER" to write the new adjustment data into memory.
9. Turn power off when you want to exit the service mode.

**Note:** Press "8" then "ENTER" on the remote commander to restore the factory settings for user controls and channel memories (this will also turn set off and then on to exit the service mode).

### 2-10-2.MEMORY WRITE CONFIRMATION METHOD

1. After adjustment, turn the power off with the remote commander.
2. Turn the power ON and set to service mode.
3. Cycle through the adjusted items again and confirm that the adjustments were saved.

### 2-10-3.ADJUSTING BUTTONS AND INDICATOR

**Note:** When the PJE mode (which displays an internally generated signal) is activated, several buttons on the remote commander will have different functions than the ones listed below. Therefore, when in the PJE mode, refer to section 2-12-3 for button functions.

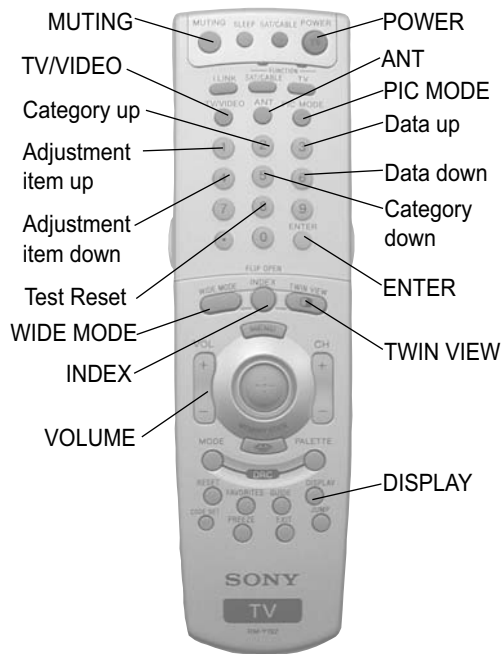

RM-Y192

## 2-11.ADJUSTABLE SERVICE DATA LISTS

Only the Adjustable registers are shown in the initial data list.

A complete set of the Initial data, Fixed and Adjustable, can be downloaded at: [http://www-ec.sdp.sel.sony.com/padics/Model\\_Data\\_List.htm](http://www-ec.sdp.sel.sony.com/padics/Model_Data_List.htm)  
Initial data can also be available in an Excel format. Please contact Nita Wardlaw at [Nita.Wardlaw@am.sony.com](mailto:Nita.Wardlaw@am.sony.com) with your request.

CATEGORY	#	ITEM	DESCRIPTION	CONDITION	51WS550	57WS550	65WS550	MIN	MAX
OP	5	OSDH	OSD Horizontal Position	(common)	21	21	21	0	255
	6	OSDF	OSD Favorite Position	(common)	28	28	28	0	63
CCPM	1	YLEV	Y Level	RF - 60HZ	205	205	205	0	255
				CV - 60HZ	190	190	190	0	255
	2	CLEV	C Level	RF - 60HZ	110	110	110	0	255
				CV - 60HZ	103	103	103	0	255
	3	SHUE	Sub Hue	RF - 60HZ	7	7	7	0	15
				CV - 60HZ	7	7	7	0	15
YCTS (CXA2163)	2	SCON	Sub Contrast	RF	9	9	9	0	15
				OTHER	6	6	6	0	15
	3	SCOL	Sub Color	RF	6	6	6	0	15
				OTHER	5	5	5	0	15
	4	SHUE	Sub Hue	RF	3	3	3	0	15
				OTHER	5	5	5	0	15
MCP	9	CBOF	Cb Offset	DRC - RF/BS/CV/YC	31	31	31	0	63
	10	CROF	Cr Offset	DRC - RF/BS/CV/YC	30	30	30	0	63
DEF1	0	VPOS	Vertical Position	COMMON	25	25	25	0	63
	1	VSIZ	Vertical Size	COMMON	31	31	31	0	63
DEF2	2	HSIZ	Horizontal Size	WIDEZOOM	24	24	24	0	63
				OTHER	24	24	24	0	63
	3	SLIN	S Linearity	WIDEZOOM	7	7	7	0	15
				OTHER	7	7	7	0	15
COLR	2	RDRV	Red Drive Gain	COMMON	38	38	38	0	63
	4	BDRV	Blue Drive Gain	COMMON	23	23	23	0	63
	5	RCUT	Red cut-off	COMMON	23	23	23	0	63
	7	BCUT	Blue cut-off	COMMON	27	27	27	0	63
	8	SBRT	Sub Bright	COMMON	23	23	23	0	63

CATEGORY	#	ITEM	DESCRIPTION	CONDITION	51WS550	57WS550	65WS550	MIN	MAX
PJE	93	R0GH	Ratio Offset S0 G H	(common)	0	0	0	-128	127
	94	R0RH	Ratio Offset S0 R H	(common)	0	0	0	-128	127
	95	R0BH	Ratio Offset S0 B H	(common)	0	0	0	-128	127
	96	R1GH	Ratio Offset S1 G H	(common)	0	0	0	-128	127
	97	R1RH	Ratio Offset S1 R H	(common)	0	0	0	-128	127
	98	R1BH	Ratio Offset S1 B H	(common)	0	0	0	-128	127
	99	R2GH	Ratio Offset S2 G H	(common)	0	0	0	-128	127
	100	R2RH	Ratio Offset S2 R H	(common)	0	0	0	-128	127
	101	R2BH	Ratio Offset S2 B H	(common)	0	0	0	-128	127
	102	R3GH	Ratio Offset S3 G H	(common)	0	0	0	-128	127
	103	R3RH	Ratio Offset S3 R H	(common)	0	0	0	-128	127
	104	R3BH	Ratio Offset S3 B H	(common)	0	0	0	-128	127
	105	R1GV	Ratio Offset S1 G V	(common)	0	0	0	-128	127
	106	R1RV	Ratio Offset S1 R V	(common)	0	0	0	-128	127
	107	R1BV	Ratio Offset S1 B V	(common)	0	0	0	-128	127
	108	R2GV	Ratio Offset S2 G V	(common)	0	0	0	-128	127
	109	R2RV	Ratio Offset S2 R V	(common)	0	0	0	-128	127
	110	R2BV	Ratio Offset S2 B V	(common)	0	0	0	-128	127
	111	PTRH	Pattern Offset Top R H	(common)	0	0	0	-128	127
	112	PTBH	Pattern Offset Top B H	(common)	0	0	0	-128	127
	113	PLRH	Pattern Offset Left R H	(common)	0	0	0	-128	127
	114	PLBH	Pattern Offset Left B H	(common)	0	0	0	-128	127
	115	PLRV	Pattern Offset Left R V	(common)	0	0	0	-128	127
	116	PLBV	Pattern Offset Left B V	(common)	0	0	0	-128	127
	117	PRRH	Pattern Offset Right R H	(common)	0	0	0	-128	127
	118	PRBH	Pattern Offset Right B H	(common)	0	0	0	-128	127
	119	PRGV	Pattern Offset Right G V	(common)	0	0	0	-128	127
	120	PRRV	Pattern Offset Right R V	(common)	0	0	0	-128	127
	121	PRBV	Pattern Offset Right B V	(common)	0	0	0	-128	127
	122	PBGH	Pattern Offset Bottom G H	(common)	0	0	0	-128	127
	123	PBRH	Pattern Offset Bottom R H	(common)	0	0	0	-128	127
	124	PBBH	Pattern Offset Bottom B H	(common)	0	0	0	-128	127
	125	ERR	Auto Regi Error Code	(common)	0	0	0	0	255
130	VUP	Auto Regi V Upper Pattern Position	(common)	50	50	50	0	2047	
131	VMID	Auto Regi V Middle Pattern Position	(common)	495	495	495	0	2047	
132	VLOW	Auto Regi V Lower Pattern Position	(common)	947	947	947	0	2047	
133	HLE	Auto Regi H Left Pattern Position	(common)	181	181	181	0	2047	
134	HMID	Auto Regi H Middle Pattern Position	(common)	853	853	853	0	2047	
135	HRIT	Auto Regi H Right Pattern Position	(common)	1522	1522	1522	0	2047	

CATEGORY	#	ITEM	DESCRIPTION	CONDITION	51WS550	57WS550	65WS550	MIN	MAX
PJE	141	CENT	R H Cent	Full / Normal	40	40	40	-512	511
				Zoom / V.Comp	40	40	40	-512	511
				WideZoom	40	40	40	-512	511
				1080i Full	40	40	40	-512	511
				1080i V.Comp	40	40	40	-512	511
			R V Cent	Full / Normal	20	20	20	-512	511
				Zoom / V.Comp	20	20	20	-512	511
				WideZoom	20	20	20	-512	511
				1080i Full	20	20	20	-512	511
				1080i V.Comp	20	20	20	-512	511
			G H Cent	Full / Normal	40	40	40	-512	511
				Zoom / V.Comp	40	40	40	-512	511
				WideZoom	40	40	40	-512	511
				1080i Full	40	40	40	-512	511
				1080i V.Comp	40	40	40	-512	511
			G V Cent	Full / Normal	20	20	20	-512	511
				Zoom / V.Comp	20	20	20	-512	511
				WideZoom	20	20	20	-512	511
				1080i Full	20	20	20	-512	511
				1080i V.Comp	20	20	20	-512	511
			B H Cent	Full / Normal	40	40	40	-512	511
				Zoom / V.Comp	40	40	40	-512	511
				WideZoom	40	40	40	-512	511
				1080i Full	40	40	40	-512	511
1080i V.Comp	40	40		40	-512	511			
B V Cent	Full / Normal	20	20	20	-512	511			
	Zoom / V.Comp	20	20	20	-512	511			
	WideZoom	20	20	20	-512	511			
	1080i Full	20	20	20	-512	511			
	1080i V.Comp	20	20	20	-512	511			

CATEGORY	#	ITEM	DESCRIPTION	CONDITION	51WS550	57WS550	65WS550	MIN	MAX
PJE	142	SIZE	R H Size	Full / Normal	-120	-120	-120	-512	511
				Zoom / V.Comp	-120	-120	-120	-512	511
				WideZoom	-120	-120	-120	-512	511
				1080i Full	-120	-120	-120	-512	511
				1080i V.Comp	-120	-120	-120	-512	511
			R V Size	Full / Normal	-80	-80	-80	-512	511
				Zoom / V.Comp	-80	-80	-80	-512	511
				WideZoom	-80	-80	-80	-512	511
				1080i Full	-80	-80	-80	-512	511
				1080i V.Comp	-80	-80	-80	-512	511
			G H Size	Full / Normal	-120	-120	-120	-512	511
				Zoom / V.Comp	-120	-120	-120	-512	511
				WideZoom	-120	-120	-120	-512	511
				1080i Full	-120	-120	-120	-512	511
				1080i V.Comp	-120	-120	-120	-512	511
			G V Size	Full / Normal	-80	-80	-80	-512	511
				Zoom / V.Comp	-80	-80	-80	-512	511
				WideZoom	-80	-80	-80	-512	511
				1080i Full	-80	-80	-80	-512	511
				1080i V.Comp	-80	-80	-80	-512	511
			B H Size	Full / Normal	-120	-120	-120	-512	511
				Zoom / V.Comp	-120	-120	-120	-512	511
				WideZoom	-120	-120	-120	-512	511
				1080i Full	-120	-120	-120	-512	511
1080i V.Comp	-120	-120		-120	-512	511			
B V Size	Full / Normal	-80	-80	-80	-512	511			
	Zoom / V.Comp	-80	-80	-80	-512	511			
	WideZoom	-80	-80	-80	-512	511			
	1080i Full	-80	-80	-80	-512	511			
	1080i V.Comp	-80	-80	-80	-512	511			

CATEGORY	#	ITEM	DESCRIPTION	CONDITION	51WS550	57WS550	65WS550	MIN	MAX
PJE	143	LIN	R H Lin	Full / Normal	300	300	300	-512	511
				Zoom / V.Comp	300	300	300	-512	511
				WideZoom	300	300	300	-512	511
				1080i Full	300	300	300	-512	511
				1080i V.Comp	300	300	300	-512	511
			R V Lin	Full / Normal	0	0	0	-512	511
				Zoom / V.Comp	0	0	0	-512	511
				WideZoom	0	0	0	-512	511
				1080i Full	0	0	0	-512	511
				1080i V.Comp	0	0	0	-512	511
			G H Lin	Full / Normal	0	0	0	-512	511
				Zoom / V.Comp	0	0	0	-512	511
				WideZoom	0	0	0	-512	511
				1080i Full	0	0	0	-512	511
				1080i V.Comp	0	0	0	-512	511
			G V Lin	Full / Normal	0	0	0	-512	511
				Zoom / V.Comp	0	0	0	-512	511
				WideZoom	0	0	0	-512	511
				1080i Full	0	0	0	-512	511
				1080i V.Comp	0	0	0	-512	511
			B H Lin	Full / Normal	-300	-300	-300	-512	511
				Zoom / V.Comp	-300	-300	-300	-512	511
				WideZoom	-300	-300	-300	-512	511
				1080i Full	-300	-300	-300	-512	511
1080i V.Comp	-300	-300		-300	-512	511			
B V Lin	Full / Normal	0	0	0	-512	511			
	Zoom / V.Comp	0	0	0	-512	511			
	WideZoom	0	0	0	-512	511			
	1080i Full	0	0	0	-512	511			
	1080i V.Comp	0	0	0	-512	511			



CATEGORY	#	ITEM	DESCRIPTION	CONDITION	51WS550	57WS550	65WS550	MIN	MAX
PJE	144	SKEW	R H Skew	Full / Normal	0	0	0	-512	511
				Zoom / V.Comp	0	0	0	-512	511
				WideZoom	0	0	0	-512	511
				1080i Full	0	0	0	-512	511
				1080i V.Comp	0	0	0	-512	511
			R V Skew	Full / Normal	0	0	0	-512	511
				Zoom / V.Comp	0	0	0	-512	511
				WideZoom	0	0	0	-512	511
				1080i Full	0	0	0	-512	511
				1080i V.Comp	0	0	0	-512	511
			G H Skew	Full / Normal	0	0	0	-512	511
				Zoom / V.Comp	0	0	0	-512	511
				WideZoom	0	0	0	-512	511
				1080i Full	0	0	0	-512	511
				1080i V.Comp	0	0	0	-512	511
			G V Skew	Full / Normal	0	0	0	-512	511
				Zoom / V.Comp	0	0	0	-512	511
				WideZoom	0	0	0	-512	511
				1080i Full	0	0	0	-512	511
				1080i V.Comp	0	0	0	-512	511
			B H Skew	Full / Normal	0	0	0	-512	511
				Zoom / V.Comp	0	0	0	-512	511
				WideZoom	0	0	0	-512	511
				1080i Full	0	0	0	-512	511
1080i V.Comp	0	0		0	-512	511			
B V Skew	Full / Normal	0	0	0	-512	511			
	Zoom / V.Comp	0	0	0	-512	511			
	WideZoom	0	0	0	-512	511			
	1080i Full	0	0	0	-512	511			
	1080i V.Comp	0	0	0	-512	511			

CATEGORY	#	ITEM	DESCRIPTION	CONDITION	51WS550	57WS550	65WS550	MIN	MAX
PJE	145	BOW	R H Bow	Full / Normal	0	0	0	-512	511
				Zoom / V.Comp	0	0	0	-512	511
				WideZoom	0	0	0	-512	511
				1080i Full	0	0	0	-512	511
				1080i V.Comp	0	0	0	-512	511
			R V Bow	Full / Normal	0	0	0	-512	511
				Zoom / V.Comp	0	0	0	-512	511
				WideZoom	0	0	0	-512	511
				1080i Full	0	0	0	-512	511
				1080i V.Comp	0	0	0	-512	511
			G H Bow	Full / Normal	0	0	0	-512	511
				Zoom / V.Comp	0	0	0	-512	511
				WideZoom	0	0	0	-512	511
				1080i Full	0	0	0	-512	511
				1080i V.Comp	0	0	0	-512	511
			G V Bow	Full / Normal	0	0	0	-512	511
				Zoom / V.Comp	0	0	0	-512	511
				WideZoom	0	0	0	-512	511
				1080i Full	0	0	0	-512	511
				1080i V.Comp	0	0	0	-512	511
			B H Bow	Full / Normal	0	0	0	-512	511
				Zoom / V.Comp	0	0	0	-512	511
				WideZoom	0	0	0	-512	511
				1080i Full	0	0	0	-512	511
1080i V.Comp	0	0		0	-512	511			
B V Bow	Full / Normal	0	0	0	-512	511			
	Zoom / V.Comp	0	0	0	-512	511			
	WideZoom	0	0	0	-512	511			
	1080i Full	0	0	0	-512	511			
	1080i V.Comp	0	0	0	-512	511			

CATEGORY	#	ITEM	DESCRIPTION	CONDITION	51WS550	57WS550	65WS550	MIN	MAX
PJE	146	KEY	R H Key	Full / Normal	0	0	0	-512	511
				Zoom / V.Comp	0	0	0	-512	511
				WideZoom	0	0	0	-512	511
				1080i Full	0	0	0	-512	511
				1080i V.Comp	0	0	0	-512	511
			R V Key	Full / Normal	130	130	130	-512	511
				Zoom / V.Comp	130	130	130	-512	511
				WideZoom	130	130	130	-512	511
				1080i Full	130	130	130	-512	511
				1080i V.Comp	130	130	130	-512	511
			G H Key	Full / Normal	0	0	0	-512	511
				Zoom / V.Comp	0	0	0	-512	511
				WideZoom	0	0	0	-512	511
				1080i Full	0	0	0	-512	511
				1080i V.Comp	0	0	0	-512	511
			G V Key	Full / Normal	0	0	0	-512	511
				Zoom / V.Comp	0	0	0	-512	511
				WideZoom	0	0	0	-512	511
				1080i Full	0	0	0	-512	511
				1080i V.Comp	0	0	0	-512	511
			B H Key	Full / Normal	0	0	0	-512	511
				Zoom / V.Comp	0	0	0	-512	511
				WideZoom	0	0	0	-512	511
				1080i Full	0	0	0	-512	511
				1080i V.Comp	0	0	0	-512	511
			B V Key	Full / Normal	-130	-130	-130	-512	511
				Zoom / V.Comp	-130	-130	-130	-512	511
				WideZoom	-130	-130	-130	-512	511
1080i Full	-130	-130		-130	-512	511			
1080i V.Comp	-130	-130		-130	-512	511			

CATEGORY	#	ITEM	DESCRIPTION	CONDITION	51WS550	57WS550	65WS550	MIN	MAX
PJE	147	PIN	R H Pin	Full / Normal	0	0	0	-512	511
				Zoom / V.Comp	0	0	0	-512	511
				WideZoom	0	0	0	-512	511
				1080i Full	0	0	0	-512	511
				1080i V.Comp	0	0	0	-512	511
			R V Pin	Full / Normal	380	380	380	-512	511
				Zoom / V.Comp	380	380	380	-512	511
				WideZoom	380	380	380	-512	511
				1080i Full	380	380	380	-512	511
				1080i V.Comp	380	380	380	-512	511
			G H Pin	Full / Normal	0	0	0	-512	511
				Zoom / V.Comp	0	0	0	-512	511
				WideZoom	0	0	0	-512	511
				1080i Full	0	0	0	-512	511
				1080i V.Comp	0	0	0	-512	511
			G V Pin	Full / Normal	430	430	430	-512	511
				Zoom / V.Comp	430	430	430	-512	511
				WideZoom	430	430	430	-512	511
				1080i Full	430	430	430	-512	511
				1080i V.Comp	430	430	430	-512	511
			B H Pin	Full / Normal	0	0	0	-512	511
				Zoom / V.Comp	0	0	0	-512	511
				WideZoom	0	0	0	-512	511
				1080i Full	0	0	0	-512	511
				1080i V.Comp	0	0	0	-512	511
			B V Pin	Full / Normal	380	380	380	-512	511
				Zoom / V.Comp	380	380	380	-512	511
				WideZoom	380	380	380	-512	511
				1080i Full	380	380	380	-512	511
				1080i V.Comp	380	380	380	-512	511
148	MLIN	R H Middle Lin	Full / Normal	0	0	0	-512	511	
			Zoom / V.Comp	0	0	0	-512	511	
			WideZoom	0	0	0	-512	511	
			1080i Full	0	0	0	-512	511	
			1080i V.Comp	0	0	0	-512	511	
		G H Middle Lin	Full / Normal	0	0	0	-512	511	
			Zoom / V.Comp	0	0	0	-512	511	
			WideZoom	0	0	0	-512	511	
			1080i Full	0	0	0	-512	511	
			1080i V.Comp	0	0	0	-512	511	
		B H Middle Lin	Full / Normal	0	0	0	-512	511	
			Zoom / V.Comp	0	0	0	-512	511	
			WideZoom	0	0	0	-512	511	
			1080i Full	0	0	0	-512	511	
			1080i V.Comp	0	0	0	-512	511	

CATEGORY	#	ITEM	DESCRIPTION	CONDITION	51WS550	57WS550	65WS550	MIN	MAX
PJE	149	MSIZ	R H Middle Size	Full / Normal	0	0	0	-512	511
				Zoom / V.Comp	0	0	0	-512	511
				WideZoom	0	0	0	-512	511
				1080i Full	0	0	0	-512	511
				1080i V.Comp	0	0	0	-512	511
			G H Middle Size	Full / Normal	0	0	0	-512	511
				Zoom / V.Comp	0	0	0	-512	511
				WideZoom	0	0	0	-512	511
				1080i Full	0	0	0	-512	511
				1080i V.Comp	0	0	0	-512	511
			B H Middle Size	Full / Normal	0	0	0	-512	511
				Zoom / V.Comp	0	0	0	-512	511
				WideZoom	0	0	0	-512	511
				1080i Full	0	0	0	-512	511
				1080i V.Comp	0	0	0	-512	511

## 2-11-1.ID MAP TABLE

CATEGORY	#	ITEM	DESCRIPTION	CONDITION	51WS550	57WS550	65WS550
ID	0	ID0	ID Byte 0	(common)	89	89	89
	1	ID1	ID Byte 1	(common)	255	255	255
	2	ID2	ID Byte 2	(common)	239	239	239
	3	ID3	ID Byte 3	(common)	107	107	107
	4	ID4	ID Byte 4	(common)	75	75	75
	5	ID5	ID Byte 5	(common)	243	243	243
	6	ID6	ID Byte 6	(common)	255	255	255
	7	ID7	ID Byte 7	(common)	27	27	27

## 2-12.REGISTRATION ADJUSTMENT (PJE MODE ONLY)

\*ADJUSTING FLOW

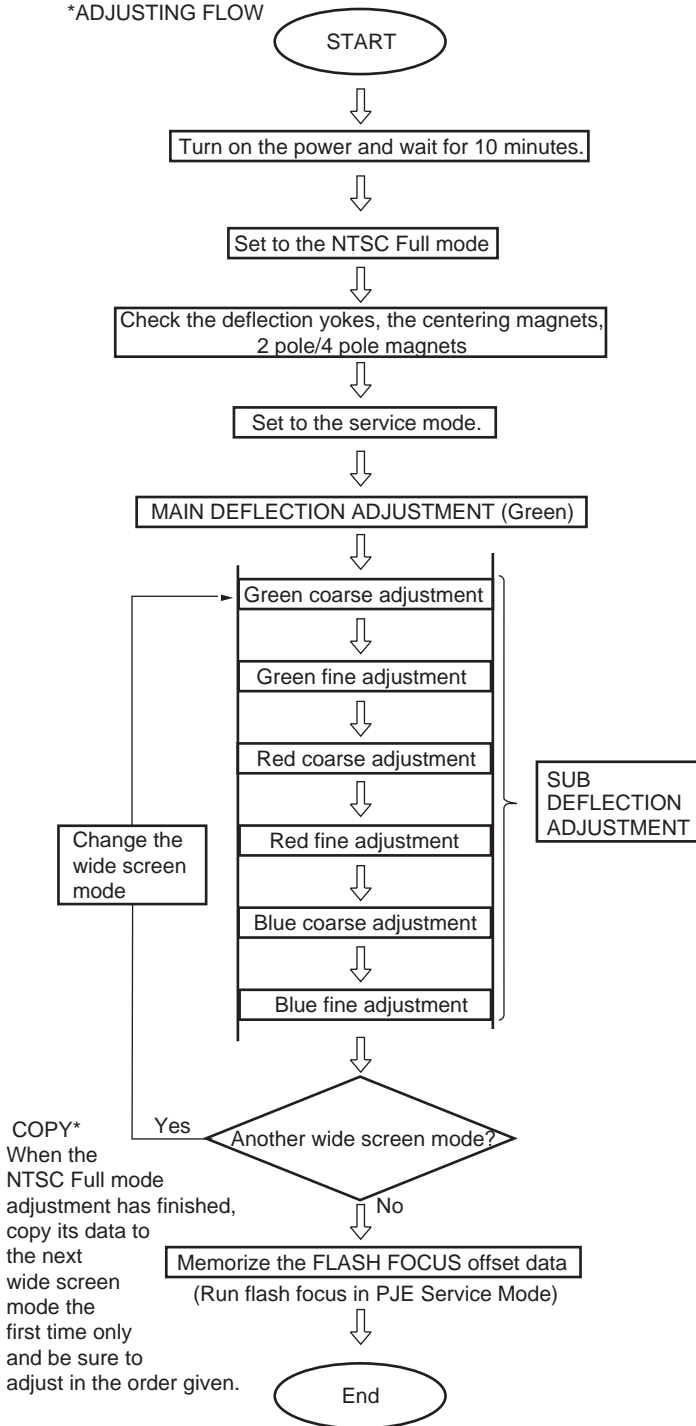

### 2-12-1.SETUP FOR ADJUSTMENT

#### MARKING

- At the 4 sides of the screen, locate the middle. Use a tape measure to identify the middle.

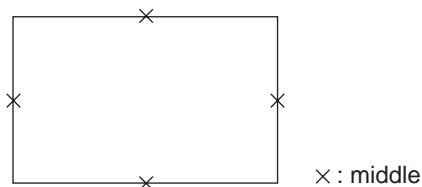

#### DATA SETTING

- Set NTSC Full mode.
- Enter the service mode, and select "PJE".

### 2-12-2.MAIN DEFLECTION ADJUSTMENT

**NOTE:** Before this adjustment, refer to section 2-11 SERVICE DATA LISTS for PJE item #141-149 input data.

- Cover the red and blue CRT lenses with lens caps to allow only green to show (or use the method shown in the note below for turning off the CRTs individually without using lens caps).
- Enter the monoscope signal and set to NTSC Full mode.
- Enter the service mode, and select "DEF1".
- Adjust "0 VPOS" and "1 VSIZ" so that the picture is displayed in the center of the screen.

0 VPOS

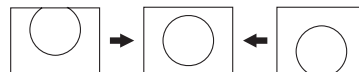

1 V-Size

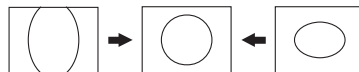

- Select "DEF2" and adjust "2 H-Size" so that the picture size is within the specification.

SPEC	Overscan Spec. = 9%	
Input Signal	H SIZE	V SIZE
Monoscope	15.6 ± 0.2 sq.	11.5 ± 0.2 sq.

2 H-Size

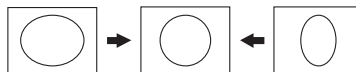

- Copy the data of the NTSC Full mode to the other wide screen mode and, if necessary, adjust in the other mode.

## 2-12-3. OPERATION METHOD FOR PROJECTOR ENGINE MODE

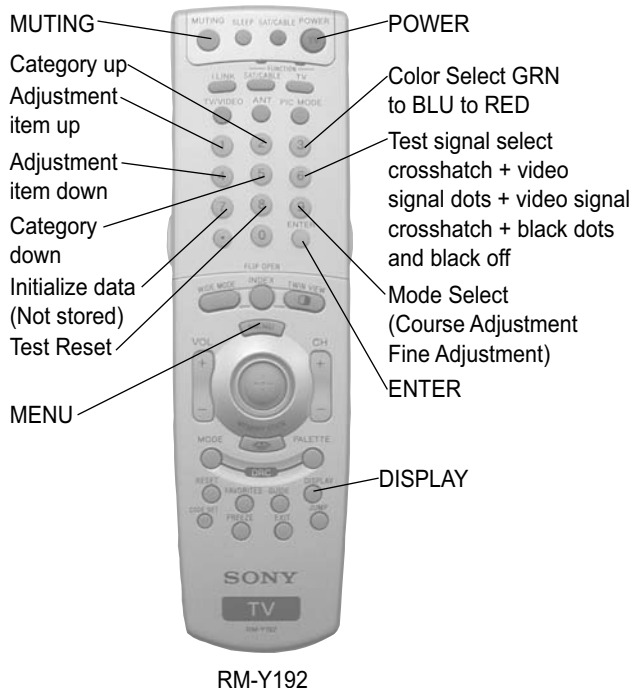

RM-Y192

### 1. FUNCTION OF KEYS ON COMMANDER

- ① Changes adjustment item. (Item # moves up)  
Marker moves clockwise from center to outside.  
(In Fine Adjustment mode)
- ④ Changes adjustment item. (Item # moves down)  
Marker moves counter clockwise from outside to center.  
(In Fine Adjustment mode)
- ② Changes adjustment category.  
(Category # moves up)
- ⑤ Changes adjustment category.  
(Category # moves down)

**Joystick** Changes data value. (Up or down)

Marker moves clockwise from center (up, down, right, and then left) to outside.  
(In Fine Adjustment mode)

- ③ Changes adjustment color.  
GRN →BLU →RED
- ⑥ Displays or changes internal test signals.  
crosshatch + external signal →  
crosshatch + borderline →  
crosshatch only →  
dot only → off
- ⑨ Switches adjustment mode.  
Coarse adjustment model →  
Fine adjustment point mode →  
Fine adjustment row mode →  
Fine adjustment column mode

**Press** Switches marker moving method.

**Joystick** (In Fine Adjustment mode)

Pressing down on the joystick in Fine Adjustment mode switches between selecting and un-selecting a point.

When a point is selected, the cursor changes to that color to indicate the point is selected and can be adjusted. If a point is not selected the cursor is white.

Joystick ▲ ▼ ◀ ▶ keys → 1 and 4 buttons

### Commander Function

Buttons	Mode	Description
0 + ENTER	READ	Reads data to NVM.
MUTING+ENTER	WRITE	Writes data from NVM.
7 + ENTER	PJE INITIAL	Service data initialization. Not stored. (Be sure not to use usually)

### 2. OPERATION METHOD FOR COARSE ADJUSTMENT

1. Enter the service mode and select "PJE".
2. Press the "1" or "4" button on the remote commander to select the item, and then use the joystick to change the data.

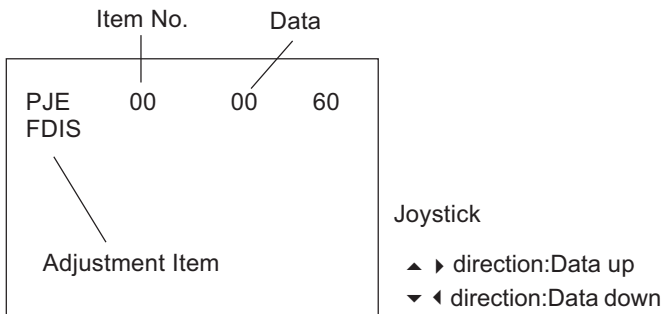

3. Select "GRN CENT". When BLU or RED is displayed, press the "3" button on the remote commander to change the adjustment color in the order of GRN →BLU →RED.
4. In the GRN, BLU, or RED mode, move the joystick ▲ or ▼ to change the data in vertical direction, or ◀ or ▶ to change the data in a horizontal direction.

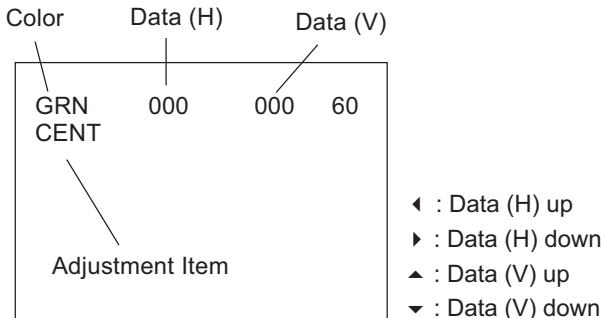

5. Before returning to the service mode, press the "MUTING" + "ENTER" buttons on the remote commander to write the data. (You must complete step 5 to write the data. If you omit step 5 the set data is returned to the data prior to the adjustment.)

**3. OPERATION METHOD FOR FINE ADJUSTMENT**

1. Enter the service mode and select "PJE".
2. Select FDIS and set the data to "01" so that the data at each position can be displayed in fine adjustment mode.
3. Press the "9" button on the remote commander and fine adjustment mode will be active where a green marker appears in the center of the screen. (In the case of GRN mode)
4. Press down on the joystick, and the marker color will be alternately switched between green (GRN mode) and white.
5. Press the "1" or "4" button on the remote commander or use the joystick to move the marker to the position to be adjusted, where fine adjustment can be made.

\* When the marker color is white:  
(in this case, fine adjustment is disabled)

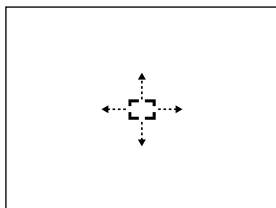

Use the joystick to move the marker up, down, left, or right.

\* When the marker color is green:  
(GRN mode)

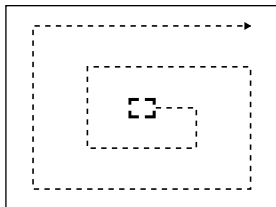

- ① : Moves the marker clockwise from the center to the outside.
- ④ : Moves the marker counter clockwise from the outside to the center.

\* Fine adjustment can be made on the basis of a marker position using the joystick to move ▲ ▼ ◀ ▶.

Move joystick ▲ direction

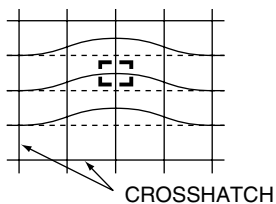

Move joystick ▶ direction

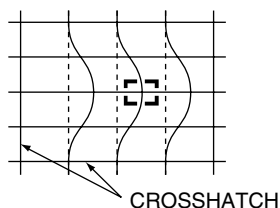

6. Press the "9" button on the remote commander to return to the coarse adjustment mode.

**2-13.PJE ADJUSTMENT (SUB DEFLECTION ADJUSTMENT)**

Adjustment item	Adjustment type		
	G	R	B
	H/V*	H/V*	H/V*
CENT	O/O	O/O	O/O
SKEW	O/O	O/O	O/O
SIZE	O/O	O/O	O/O
LIN	O/O	O/O	O/O
BOW	O/O	O/O	O/O
KEY	O/O	O/O	O/O
PIN	O/O	O/O	O/O
MLIN	O/-	O/-	O/-
MSIZ	O/-	O/-	O/-

\* H = Horizontal V = Vertical O = Yes - = No

**Note:** If the value is over the limit value, adjust these in the fine adjustment.

**Coarse Data Limit Value:**

CENT H	-135 TO + 205
CENT V	-150 TO + 190
SKEW	-75 TO + 75
SIZE H	-75 MAX
BLUE H LIN	-425 MIN
RED H LIN	+425 MAX
FINE DATA LIMIT	± 107
Except the extreme left & right outside columns which have no limit	



## 2-13-1.ADJUSTMENT FOR NTSC FULL MODE

- The adjustment should be done in the numerical order given.

### 1) GREEN ADJUSTMENT

- Cover the red and blue CRT lenses with lens caps to allow only green to show (or use the method shown in the note below for turning off the CRTs individually without using lens caps).
- Enter the monoscope signal to set.
- Select the PJE mode.
- Press the "6" button on the remote commander to display the internal test signal (crosshatch).
- Select "GRN CENT", and adjust so that the pictures coincide in the center of screen.

**Note:** If lens caps are unavailable, you can cut off the unnecessary color beams by controlling the service mode MCP-RON, GON, BON.

#### GRN CENT (Horizontally/Vertically)

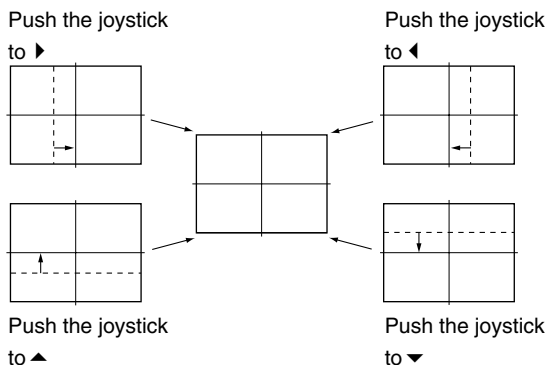

- Select "GRN SKEW", and correct the tilt of horizontal lines and vertical lines.

#### GRN SKEW (Horizontally/Vertically)

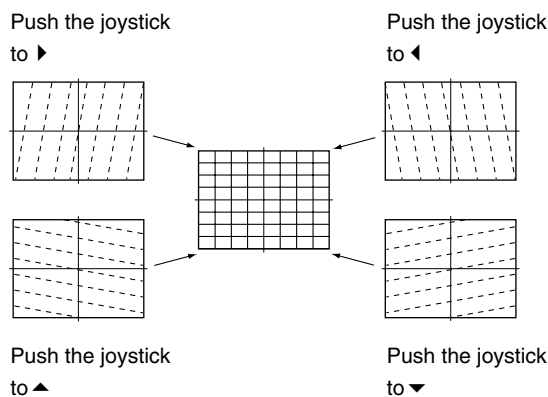

- Select "GRN SIZE", and adjust so that each distance from center to left end and to right end is equal. Adjust so that each distance from center to top and to bottom is equal.

#### GRN SIZE (Horizontally/Vertically)

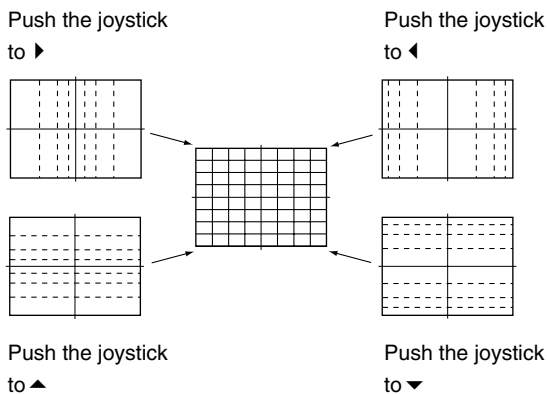

- Select "GRN LIN", and adjust so that each space at the right end and at the left end of screen is equal. Adjust so that each space at the top and at the bottom of screen is equal.

#### GRN LIN (Horizontally/Vertically)

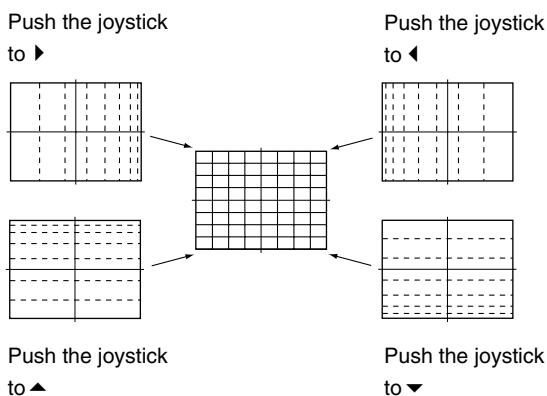

- Select "GRN BOW", and adjust so that the raster is not curved.

#### GRN BOW (Horizontally/Vertically)

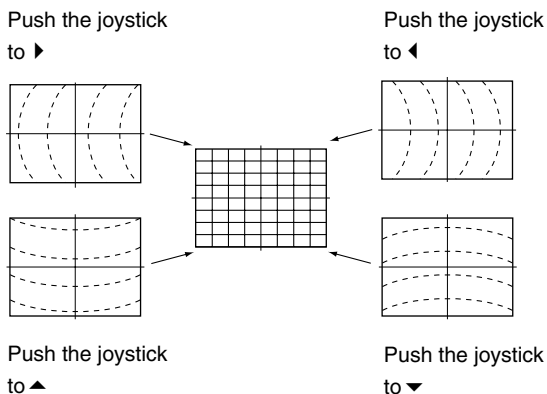

11. Select "GRN MSIZ", and correct the space intervals for the horizontal section so the screen is equal.

#### GRN MSIZ (Horizontally)

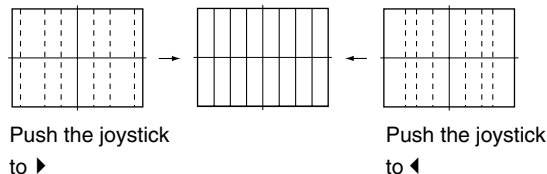

12. Select "GRN MLIN", and correct the sizes of the horizontal line so the center of the screen is symmetrical left and right.

#### GRN MLIN (Horizontally)

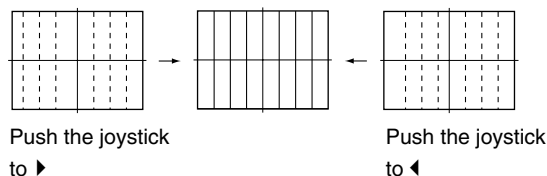

**Note:** The SIZE and LIN, MSIZ and MLIN adjustments affect each other. If necessary, adjust these mutually.

13. Select "GRN PIN", and adjust so that right and left vertical lines on the screen become straight. Adjust so that upper and lower horizontal lines on the screen become straight.

#### GRN PIN (Horizontally/Vertically)

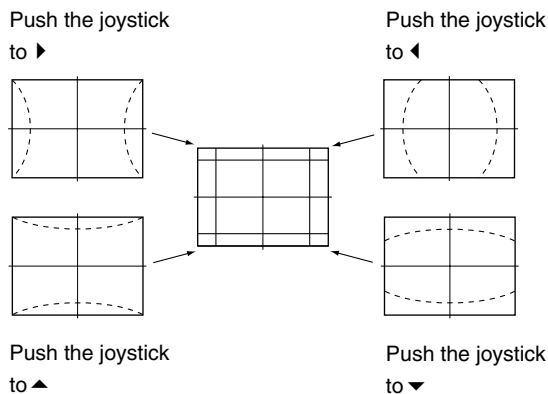

14. Select "GRN KEY", and adjust so that upper and lower horizontal lines on the screen become parallel.

#### GRN KEY (Vertically)

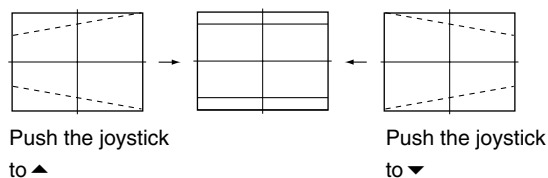

**Note:** The VPIN and KEY adjustments affect each other. If necessary, adjust these mutually.

15. Press the "9" button on the remote commander to enter fine adjustment mode.
16. Make the fine adjustment so that horizontal lines and vertical lines become straight.
17. Press the "9" button on the remote commander to return to coarse adjustment mode.

## 2) RED ADJUSTMENT

- Cover the blue CRT lens with a lens caps to allow only the green and red to show (or use the method shown in the note below for turning off the CRTs individually without using lens caps).
- Press the "3" button on the remote commander to select RED mode.
- Adjust the following items so that red lines overlap with green lines.
  - RED CENT (horizontally/vertically)
  - RED SKEW (horizontally/vertically)
  - RED SIZE (horizontally/vertically)
  - RED LIN (horizontally/vertically)
  - RED MSIZ (horizontally)
  - RED MLIN (horizontally)
  - RED PIN (horizontally/vertically)
  - RED KEY (vertically)
- Press the "9" button on the remote commander to enter fine adjustment mode.
- Make the fine adjustment so that horizontal lines and vertical lines overlap with green lines.
- Press the "9" button on the remote commander to return to coarse adjustment mode.

**Note:** If lens caps are unavailable, you can cut off the unnecessary color beams by controlling the service mode MCP-RON, GON, BON.

## 3) BLUE ADJUSTMENT

- Remove the lens cap from the blue picture lens to display all colors.
- Press the "3" button on the remote commander to select BLU mode.
- Adjust the following items so that blue lines overlap with green lines.
  - BLU CENT (horizontally/vertically)
  - BLU SKEW (horizontally/vertically)
  - BLU SIZE (horizontally/vertically)
  - BLU LIN (horizontally/vertically)
  - BLU PIN (horizontally/vertically)
  - BLU KEY (vertically)
- Press the "9" button on the remote commander to enter fine adjustment mode.
- Make the fine adjustment so that horizontal lines and vertical lines overlap with green and red lines.
- Press the "9" button on the remote commander to return to coarse adjustment mode.

**Note:** When replacing CRTs, adjust the set-up adjustments (2-1 to 2-9) and the registration adjustment (2-12). When replacing multiple CRTs at the same time, replace and adjust them individually.

## 4) REGISTRATION DATA WRITING

1. After completing each adjustment of green, blue, and red for the NTSC Full mode press the "MUTING"+ "ENTER" buttons in PJE service mode on the remote commander to write the registration data to the NVM.

### 2-13-2. COPYING ALL REGISTRATION DATA TO OTHER MODES

1. Make sure that the adjustment for NTSC Full mode are complete and the data have already been written.
2. Select the PJE mode.
3. Select Copy and set the data to "01", and press the "MUTING"+"ENTER" buttons on the remote commander.
4. The data from the NTSC Full mode is copied to all other modes.

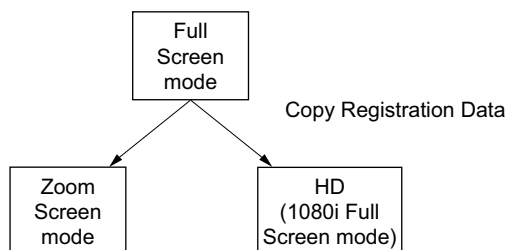

5. Check in the other modes and adjust as demands.

**Be sure to write data in each mode.**

**Note:** If no 1080i source is available, 1080i data can be displayed by entering Twin mode.

## 2-14.AUTO REGISTRATION OFFSETS

### IMPORTANT

**This adjustment must be performed after registration adjustment or after readjustment for any reason!**

Once registration in all modes is satisfactory:

1. Darken the room environment near the set.
2. Select input of RF (with a signal) or Video1 - Video4 (with a signal), and enter Full Mode.

**WARNING: DO NOT USE 1080i SIGNAL!**

3. Enter service mode and select the PJE group.
4. Press the "MUTING" + "ENTER" buttons on the remote commander to write the data for Full mode.

### Important:

You must complete step 4 even if registration looks OK in Full mode and there were not any adjustments made.

5. To automatically store the offset values, press the "FLASH FOCUS" button on the front panel of the set.

(The offset value is now stored)

If FLASH FOCUS successfully calibrates, it displays "CALIBRATION OK."

If FLASH FOCUS does not successfully calibrate, an error message is displayed. (Refer to section 2-15)

6. Exit the service mode.
7. If the calibration was successful, press the "FLASH FOCUS" button out of service mode.
8. Confirm registration is OK in all modes.

## 2-15.AUTO REGISTRATION ERROR CODES

If an error code is displayed after the set has been correctly adjusted, check the following items: position, tilt and sizing. If any of these adjustments are off, even slightly, the auto-registration pattern will not hit the four sensors properly. This occurs when the internal generator patterns are being flashed on the screen for the sensors to read. Therefore, auto registration (called auto convergence) cannot operate properly, causing an error code to be displayed. In order for this function to operate properly, position, tilt and size must be adjusted properly.

### ERROR CODE LIST

ERROR CODE	DESCRIPTION	NOTE
00	No Error	
10	Sensor 0 low output	Check sensor 0, connection/wiring, circuit, and pattern position (are patterns hitting sensor?) adjust 130 VUP, 134 HMID if necessary.
11	Sensor 1 low output	Check sensor 1, connection/wiring, circuit, and pattern position (are patterns hitting sensor?) adjust 133 HLE, 131 VMID if necessary.
12	Sensor 2 low output	Check sensor 2, connection/wiring, circuit, and pattern position (are patterns hitting sensor?) adjust 135 HRIV, 131 VMID if necessary.
13	Sensor 3 low output	Check sensor 3, connection/wiring, circuit, and pattern position (are patterns hitting sensor?) adjust 132 VLOW, 134 HMID if necessary.
20	Sensor 0 high output	Check sensor 0 and circuit.
21	Sensor 1 high output	Check sensor 1 and circuit.
22	Sensor 2 high output	Check sensor 2 and circuit.
23	Sensor 3 high output	Check sensor 3 and circuit.
30	V CENT or SKEW adjustment loop overflow	Check 131 VMID data and check registration condition.
31	H CENT or SKEW adjustment loop overflow	Check 134 HMID data and check registration condition.
32	H LIN or SIZE adjustment loop overflow	Check 133 HLE and 135 HRIT data and check registration condition.
40	V CENT regi data overflow	Check 131 VMID data and confirm V CENT data (all modes) is not near 511.
41	H CENT regi data overflow	Check 134 HMID data and confirm H CENT data (all modes) is not near 511.
42	V SKEW regi data overflow	Check 131 VMID data and confirm V SKEW data (all modes) is not near 511.
43	H SKEW regi data overflow	Check 134 HMID data and confirm H SKEW data (all modes) is not near 511.
44	H LIN regi data overflow	Check 133 HLE and 135 HRIT data and confirm H CENT data (all modes) is not near 511.
45	H SIZE regi data overflow	Check 133 HLE and 135 HRIT data and confirm H CENT data (all modes) is not near 511.
50	V CENT regi data overdraw	Check 131 VMID data and confirm V CENT data (all modes) is not near -512.
51	H CENT regi data overdraw	Check 134 HMID data and confirm H CENT data (all modes) is not near -512.
52	V SKEW regi data overdraw	Check 131 VMID data and confirm V SKEW data (all modes) is not near -512.
53	H SKEW regi data overdraw	Check 134 HMID data and confirm H SKEW data (all modes) is not near -512.
54	H LIN regi data overdraw	Check 133 HLE and 135 HRIT data and confirm H CENT data (all modes) is not near -512.
55	H SIZE regi data overdraw	Check 133 HLE and 135 HRIT data and confirm V CENT data (all modes) is not near -512.
60	CENT/SKEW calibration loop overflow	Check 134 HMID and 131 VMID data and check registration condition.
61	SIZE/LIN calibration loop overflow	Check 133 HLE, 135 HRIT, 130 VUP, and 132 VLOW data and check registration condition.
70	V CENT/SKEW ratio limit	Check sensors 1 and 2, connection/wiring, circuit, increase 129 RTML.
71	H CENT/SKEW ratio limit	Check sensors 0 and 3, connection/wiring, circuit, increase 129 RTML.
73	H SIZE/Lin ratio limit	Check sensors 1 and 2, connection/wiring, circuit, increase 129 RTML.
80	SIZE Limit Error	Check that horizontal SIZE data is not near 128 SZLM.

\* In the case of multiple errors, last error is displayed.

**SENSOR POSITIONS**

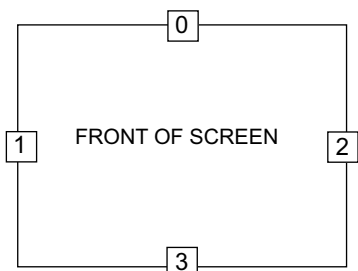

- 0: UPPER SENSOR
- 1: LEFT SENSOR
- 2: RIGHT SENSOR
- 3: LOWER SENSOR

**• ERROR CODE SCREEN DISPLAY**

Error codes in normal (customer) mode are not displayed. You must enter PJE service mode to see the error code.

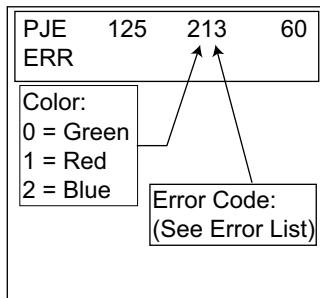

(Blue Sensor 3 Low Output)

In service mode, the error will be displayed in text format.

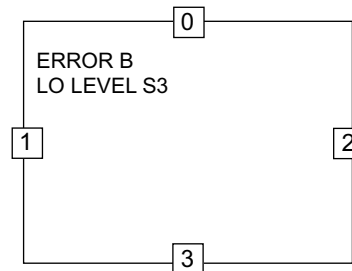

**2-16.AUTO REGISTRATION DIAGNOSTICS**

The TEST service item (PJE #136) can be used to determine if a sensor or sensor amplifier is working properly. It can also be used to check pattern positions.

**133**

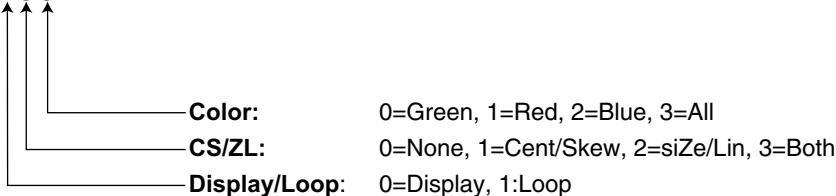

DISPLAY/ LOOP	CS/ZL	COLOR	ACTION
(0)	0	0	Normal calibration (no diagnostics).
(0)	X	X	Performs one adjustment cycle, then displays average peak voltages for the specified CS/ZL and Color.
(0)	3	3	Does nothing (can't display more than one CS/ZL or Color at a time.)
1	X	X	Adjusts specified CS/ZL and Color until a key is pressed. Useful for measuring signals with oscilloscope.

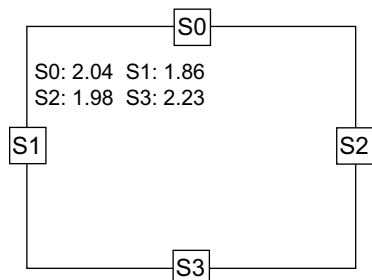



Sensor 0 peak voltage = 2.04 V, etc.

## SECTION 3: SAFETY-RELATED ADJUSTMENTS

### D BOARD

#### 3-1. HV REGULATION CIRCUIT CHECK AND ADJUSTMENT

When replacing the following components marked with a  on the schematic diagram always check the HV regulation, and if necessary re-adjust.

Part Replaced (  )
<b>D BOARD:</b> T8001 (RHT), IC8001, IC8002, IC8004, IC8005, IC8104, PH8003, R8008, R8012, R8014, R8015, R8016, R8017, R8019, R8046, R8052, R8060, R8072, R8078, R8079, R8165, D8022

#### HV REGULATION ADJUSTMENT

1. Receive the all white signal.
2. Set PIC MAX/BRT CENT.
3. Connect a HV static voltmeter to the unconnected plug of the high-voltage block.
4. Power on the set.
5. Receive the all white signal.
6. Set PIC MAX/BRT CENT.
7. Confirm that the static voltmeter reading is  $31.0 \pm 0.4V$ .
8. If not, adjust with VR8001 to the specified value.
9. After adjustment, put the VR cover on VR8001 (as shown below) and apply sufficient amount of epoxy resin around VR8001.

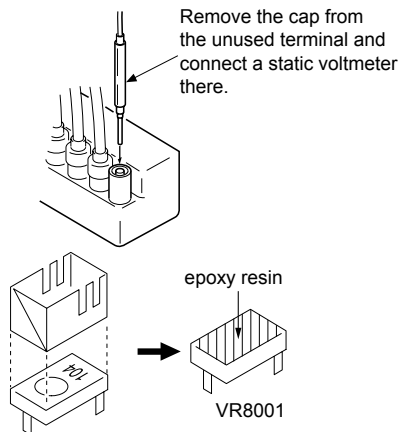

#### 3-2. HV HOLD DOWN CIRCUIT OPERATION CHECK

When replacing the following components marked with a  on the schematic diagram always check the hold-down operation.

Part Replaced (  )
<b>D BOARD:</b> T8001 (RHT), IC8002, IC8004, IC8005, PH8003, R8012, R8014, R8015, R8017, R8027, R8029, R8030, R8031, R8035, R8036, R8037, R8038, R8039, R8040, R8041, R8043, R8082, R8060, Q8007, Q8008

#### OPERATION CHECK

1. Receive any source.
2. Using an external DC supply, apply 5 VDC to pin 3 of CN1504 on UA Board. Set will shutdown.

## G BOARD

### 3-3. +B MAX VOLTAGE CONFIRMATION

The following adjustments should always be performed when replacing IC6503 R6590.

1. Supply 130VAC to variable autotransformer.
2. Receive dot signal pattern and set the PICTURE and BRIGHTNESS settings to their minimum.
3. Confirm the voltage of TP +B 135V is less than 137.0Vdc.
4. If step 3 is not satisfied, replace IC6503 and repeat steps 1-3.

### 3-4. +B OVP CONFIRMATION

1. Turn on set.
2. Set input conditions.
3. Turn off set.
4. Separate R6809 (D Board) from +135.
5. Apply external  $145 \pm 1V$  DC to open end of R6809.
6. Turn on set.
7. Measure voltage at Pin + of CN5007 (D Board). Voltage should be less than 0.8V.

#### Input Conditions

Input Voltage: 120VAC

Input Signal: Dot pattern NTSC

Video Controls: PICTURE set to minimum  
BRIGHTNESS set to minimum

## SECTION 4: CIRCUIT ADJUSTMENTS

### 4-1. P & P SUB CONTRAST ADJUSTMENT (VIDEO) (SCON)

- Receive the signal.  
VIDEO 1 terminal Composite: Color-bar (white-75%, 7.5% setup)
- VIDEO MODE : Pro  
PICTURE : Maximum  
COLOR : Minimum  
MCP RON = 0  
BON = 0
- Set to P & P mode, and receive the color bars in both main and sub (left and right), and set to service mode.
- Connect an oscilloscope between the check point and ground.  
Check points : UA Board CN1504 pin 6 (G)
- Select "CCPM-YLEV" (Main scon), and adjust so that the waveform level of VWB is  $1.75 \pm 0.03V_{p-p}$ .
- Select "YCTS-SCON" (Sub scon), and adjust so that the waveform level of VWB is  $1.75 \pm 0.03V_{p-p}$ .
- After completing the adjustments, write the data into memory by pressing "MUTING" → "ENTER" on the remote commander.

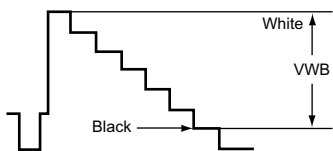

### 4-2. P & P SUB CONTRAST ADJUSTMENT (RF) (SCON)

- Receive the signal.  
TV terminal RF : Color-bar (white-75%, 7.5% setup)
- VIDEO MODE : Pro  
PICTURE : Maximum  
COLOR : Minimum  
MCP RON = 0  
BON = 0
- Set to P & P mode, and receive the color bars in both main and sub (left and right), and set to service mode.
- Connect an oscilloscope between the check point and ground.  
Check points : UA Board CN1504 pin 6 (G)
- Select "CCPM-YLEV" (Main scon), and adjust so that the waveform level of VWB is  $1.75 \pm 0.03V_{p-p}$ .
- Select "YCTS-SCON" (Sub scon), and adjust so that the waveform level of VWB is  $1.75 \pm 0.03V_{p-p}$ .
- After completing the adjustments, write the data into memory by pressing "MUTING" → "ENTER" on the remote commander.

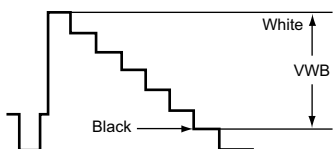

### 4-3. P & P SUB-HUE AND SUB-COLOR ADJUSTMENT VIDEO (SHUE, SCOL)

- Receive the signal.  
VIDEO 1 terminal Composite: Color-bar (white-75%, 7.5% setup)
- VIDEO MODE : Pro  
PICTURE : Maximum  
COLOR : Center
- Set to P & P mode, and receive the color bars in both main and sub (left and right), set to service mode.
- Connect an oscilloscope between pin 7 of CN1504 (UA Board) connector and ground.
- Select "CCPM-CLEV, CCPM-SHUE" (Main), and adjust them to have  $VB1 \leq VB4$  and  $VB2 \leq VB3$  in the waveform levels.
- Select "YCTS-SCOL, YCTS-SHUE" (Sub), and adjust them to have  $VB1 \leq VB4$  and  $VB2 \leq VB3$  in the waveform levels.
- After completing the adjustments, write the data into memory by pressing "MUTING" → "ENTER" on the remote commander.

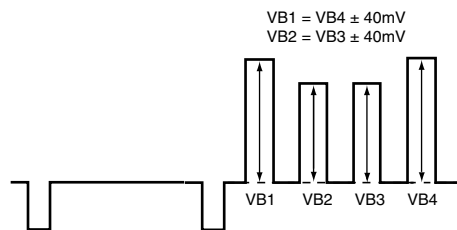

### 4-4. P & P SUB-HUE AND SUB-COLOR ADJUSTMENT (RF) (SHUE, SCOL)

- Receive the signal.  
TV terminal : Color-bar (white-75%, 7.5% setup)
- VIDEO MODE : Pro  
PICTURE : Maximum  
COLOR : Center
- Set to P & P mode, and receive the color bars in both main and sub (left and right), set to service mode.
- Connect an oscilloscope between pin 7 of CN1504 (UA Board) connector and ground.
- Select "CCPM-CLEV, CCPM-SHUE" (Main), and adjust them to have  $VB1 \leq VB4$  and  $VB2 \leq VB3$  in the waveform levels.
- Select "YCTS-SCOL, YCTS-SHUE" (Sub), and adjust them to have  $VB1 \leq VB4$  and  $VB2 \leq VB3$  in the waveform levels.
- After completing the adjustments, write the data into memory by pressing "MUTING" → "ENTER" on the remote commander.

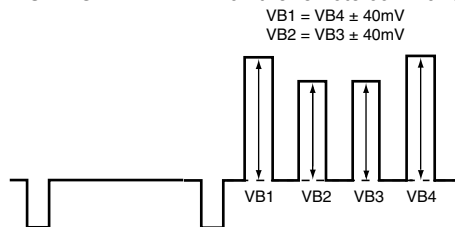



#### 4-5. BLUE OFFSET ADJUSTMENT

1. Receive the all black (1080i, component) signal with VIDEO 5 input, and set PICTURE to maximum.
2. Connect an oscilloscope between CN1504 7 pin (B) on the (UA board) and ground.
3. Set in the service mode and select the category "DEF2-SLIN".
4. Adjust "3 SLIN" so that the waveform level is  $2.15 \pm 0.05V_{pp}$ .
5. After completing the adjustments, write the data into memory by pressing "MUTING" → "ENTER" on the remote commander.
6. Receive the RF signal and change the wide screen mode to "Wide Zoom". Copy the same data to "DEF2-SLIN".

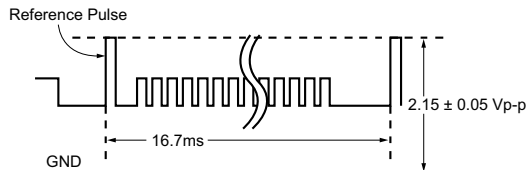

# SECTION 5: DIAGRAMS

## 5-1. CIRCUIT BOARDS LOCATION

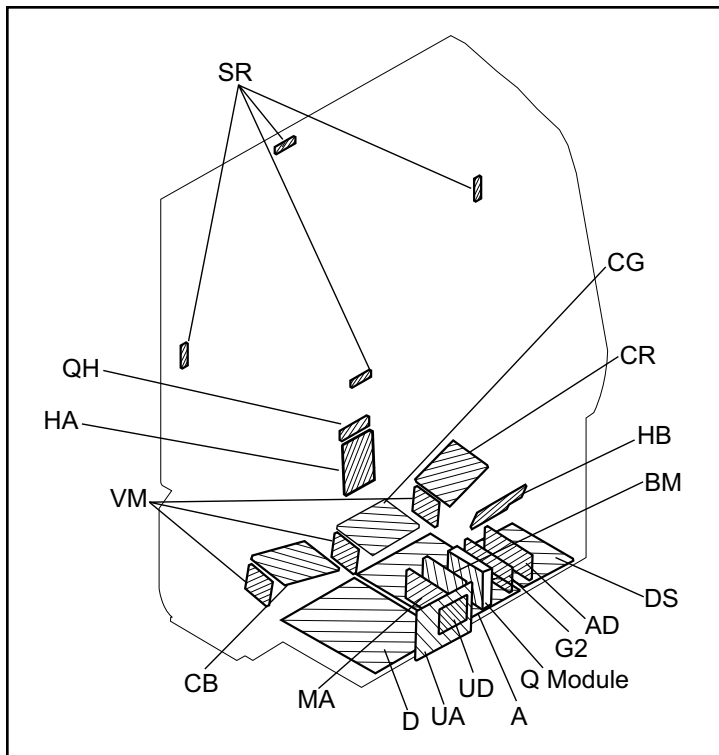

- : B+ line
- : B-line. (Actual measured value may be different).
- ⇒ : signal path. (RF)

Circled numbers are waveform references.

The components identified by in this basic schematic diagram have been carefully factory-selected for each set in order to satisfy regulations regarding X-ray radiation. Should replacement be necessary, replace only with the value originally used.

When replacing components identified by , make the necessary adjustments as indicated. If the results do not meet the specified value, change the component identified by and repeat the adjustment until the specified value is achieved.

(Refer to adjustments in Sections 3-1 and 3-2.)

When replacing the parts listed in the table below, it is important to perform the related adjustments.

## 5-2. PRINTED WIRING BOARDS AND SCHEMATIC DIAGRAMS INFORMATION

All capacitors are in  $\mu\text{F}$  unless otherwise noted. pF :  $\mu\text{F}$  50VV or less are not indicated except for electrolytics and tantalums.

All electrolytics are in 50V unless otherwise specified.

All resistors are in ohms. K=1000, M=1000k

Indication of resistance, which does not have one for rating electrical power, is as follows: Pitch : 5mm

Rating electrical power :  $\frac{1}{4}$  W

$\frac{1}{4}$  W in resistance,  $\frac{1}{10}$  W and  $\frac{1}{8}$  W in chip resistance.

: nonflammable resistor.

: fusible resistor.

: internal component.

: panel designation and adjustment for repair.

: earth ground

: earth-chassis

All variable and adjustable resistors have characteristic curve B, unless otherwise noted.

Readings are taken with a NTSC color-bar signal input.

Readings are taken with a 10M digital multimeter.

Voltages are DC with respect to ground unless otherwise noted.

Voltage variations may be noted due to normal production tolerances.

All voltages are in V.

S : Measurement impossibility.

Part Replaced ()
<p><b>D BOARD:</b>                      T8001 (RHT), IC8001,                      IC8002, IC8004, IC8005,                      IC8104, PH8003, R8008,                      R8012, R8014, R8015,                      R8016, R8017, R8019,                      R8046, R8052, R8060,                      R8072, R8078, R8079,                      R8165, D8022</p>

Part Replaced ()
<p><b>D BOARD:</b>                      T8001 (RHT), IC8002,                      IC8004, IC8005, PH8003,                      R8012, R8014, R8015,                      R8017, R8027, R8029,                      R8030, R8031, R8035,                      R8036, R8037, R8038,                      R8039, R8040, R8041,                      R8043, R8082, R8060,                      Q8007, Q8008</p>

## REFERENCE INFORMATION

RESISTOR : RN METAL FILM  
 : RC SOLID  
 : FPRD NONFLAMMABLE CARBON  
 : FUSE NONFLAMMABLE FUSIBLE  
 : RW NONFLAMMABLE WIREWOUND  
 : RS NONFLAMMABLE METAL OXIDE  
 : RB NONFLAMMABLE CEMENT  
 : ※ ADJUSTMENT RESISTOR

COIL : LF-8L MICRO INDUCTOR

CAPACITOR : TA TANTALUM  
 : PS STYROL  
 : PP POLYPROPYLENE  
 : PT MYLAR  
 : MPS METALIZED POLYESTER  
 : MPP METALIZED POLYPROPYLENE  
 : ALB BIPOLAR  
 : ALT HIGH TEMPERATURE  
 : ALR HIGH RIPPLE











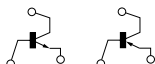

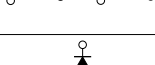





















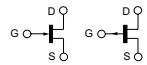

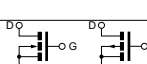

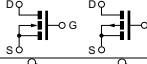

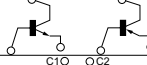

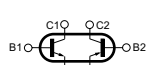

The components identified by shading and  symbol are critical for safety. Replace only with part number specified.

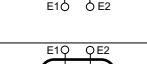
The symbol  indicates a fast operating fuse and is displayed on the component side of the board. Replace only with fuse of the same rating as marked.

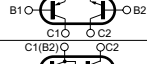
Les composants identifiés par un trame et une marque  sont critiques pour la securite. Ne les remplacer que par une piece portant le numero specifie.

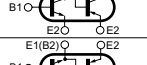
Le symbole  indique une fusible a action rapide. Doit etre remplace par une fusible de meme yaleur, comme maque.

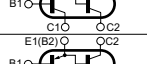
Terminal name of semiconductors in silk screen printed circuit ( \* )

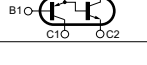
	Device	Printed symbol	Terminal name	Circuit
①	Transistor		Collector Base Emitter	
②	Transistor		Collector Base Emitter	
③	Diode		Cathode Anode	
④	Diode		Cathode Anode (NC)	
⑤	Diode		Cathode Anode (NC)	
⑥	Diode		Common Anode Cathode	
⑦	Diode		Common Anode Cathode	
⑧	Diode		Common Anode Anode	
⑨	Diode		Common Anode Anode	
⑩	Diode		Common Cathode Cathode	
⑪	Diode		Common Cathode Cathode	
⑫	Diode		Anode Cathode Anode Anode Cathode Anode	
⑬	Transistor (FET)		Drain Source Gate	
⑭	Transistor (FET)		Drain Source Gate	
⑮	Transistor (FET)		Source Drain Gate	
⑯	Transistor		Emitter Collector Base	
⑰	Transistor		C2 B1 E1 E2 B2 C1	
⑱	Transistor		C1 B2 E2 E1 B1 C2	
⑲	Transistor		C1 B2 E2 E1 B1 C2	
⑳	Transistor		C1 B2 E2 E1 B1 C2	
㉑	Transistor		E2 B1 E1 C2 C1(B2)	
㉒	Transistor		(B2) B1 E1 E2 C1 C2	
㉓	Transistor		(B2) E2 E1 B1 C2 C1	
-	Discrete semiconductor			

(Chip semiconductors that are not actually used are included.)

Ver.1.6

5-3. BLOCK DIAGRAMS

VIDEO SIGNAL FLOW BLOCK DIAGRAM

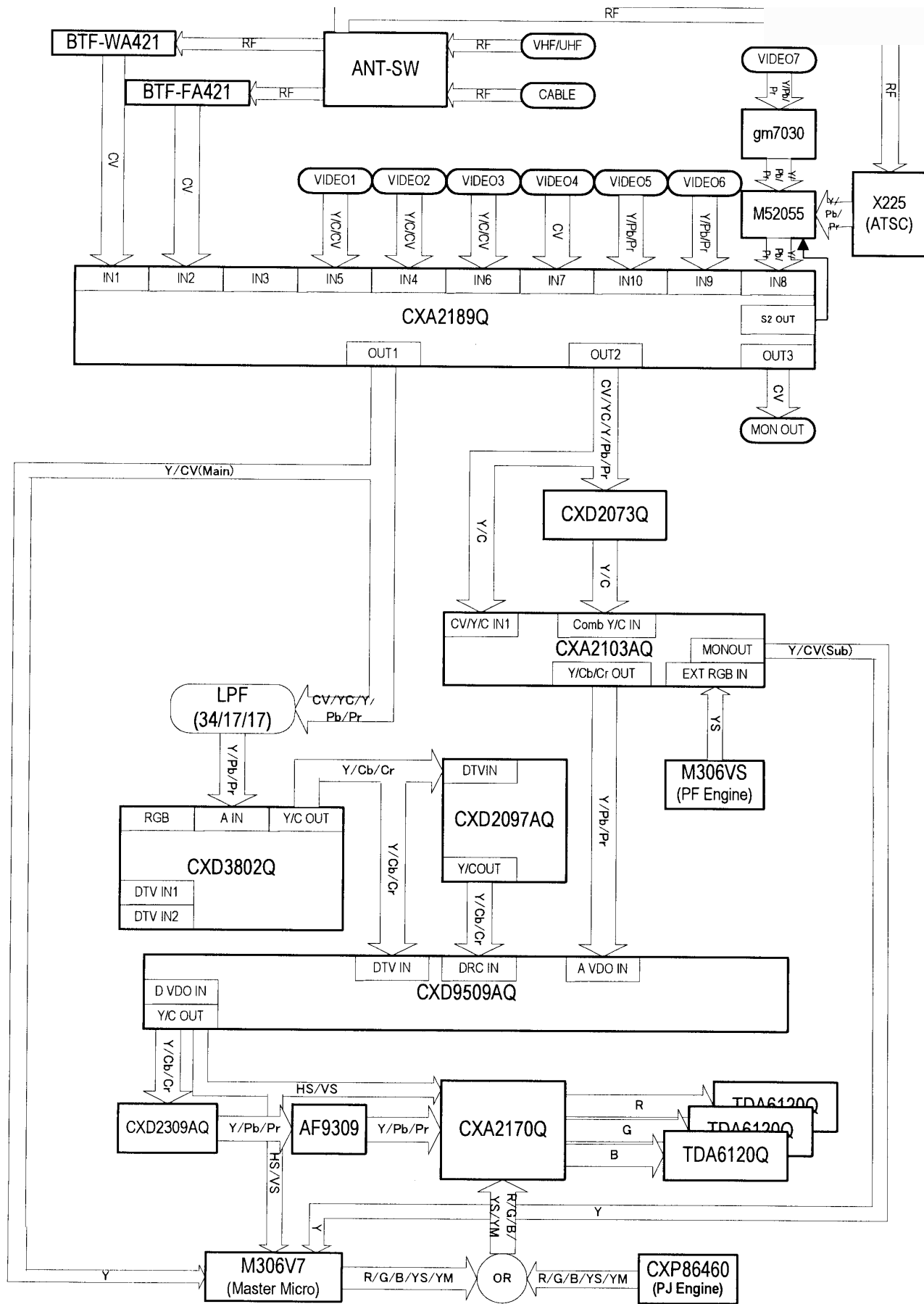

POWER SUPPLY

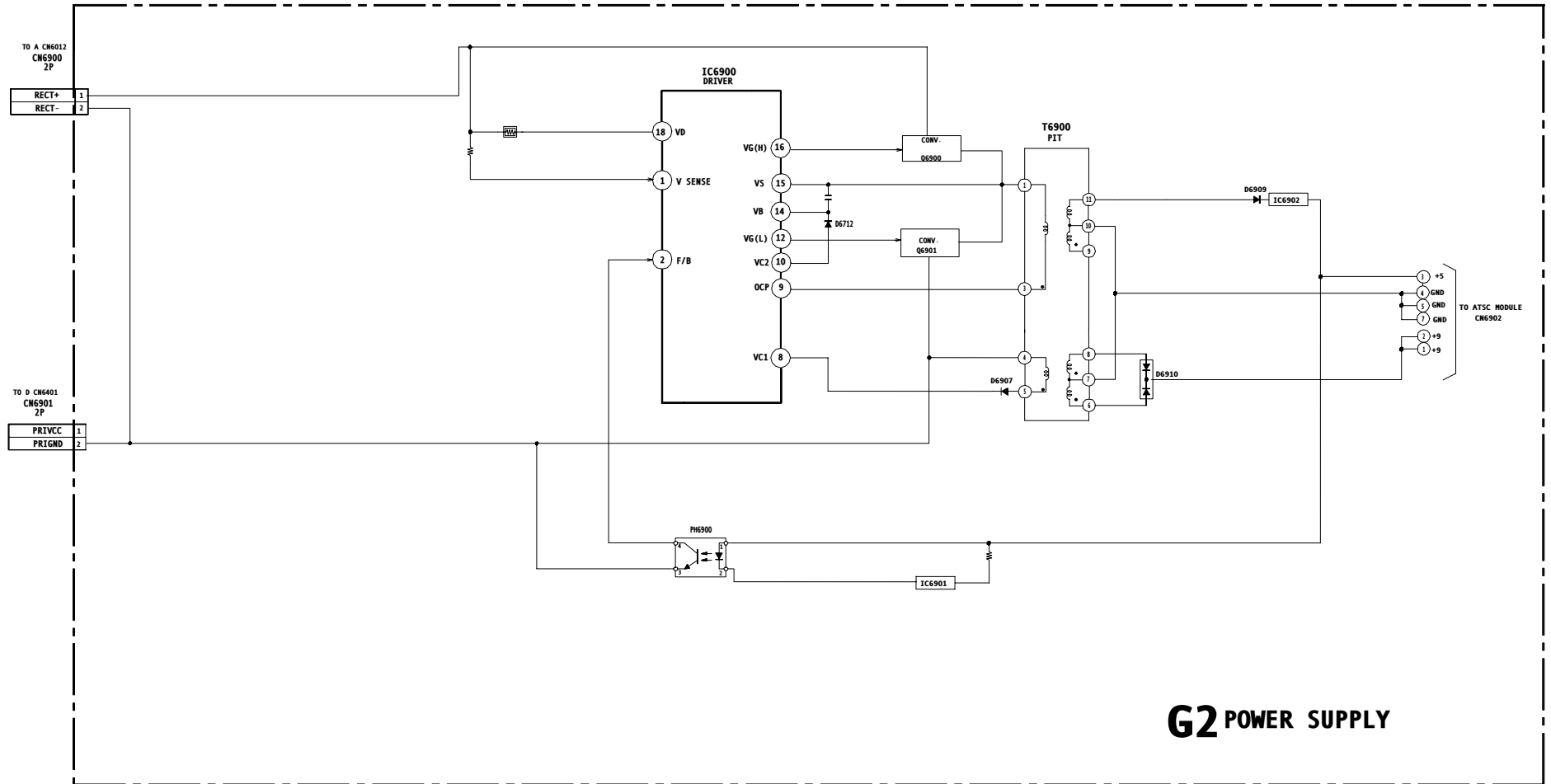

MUTE & BLANKING CONTROL BLOCK DIAGRAM WITH MAJOR SIGNAL-FLOW

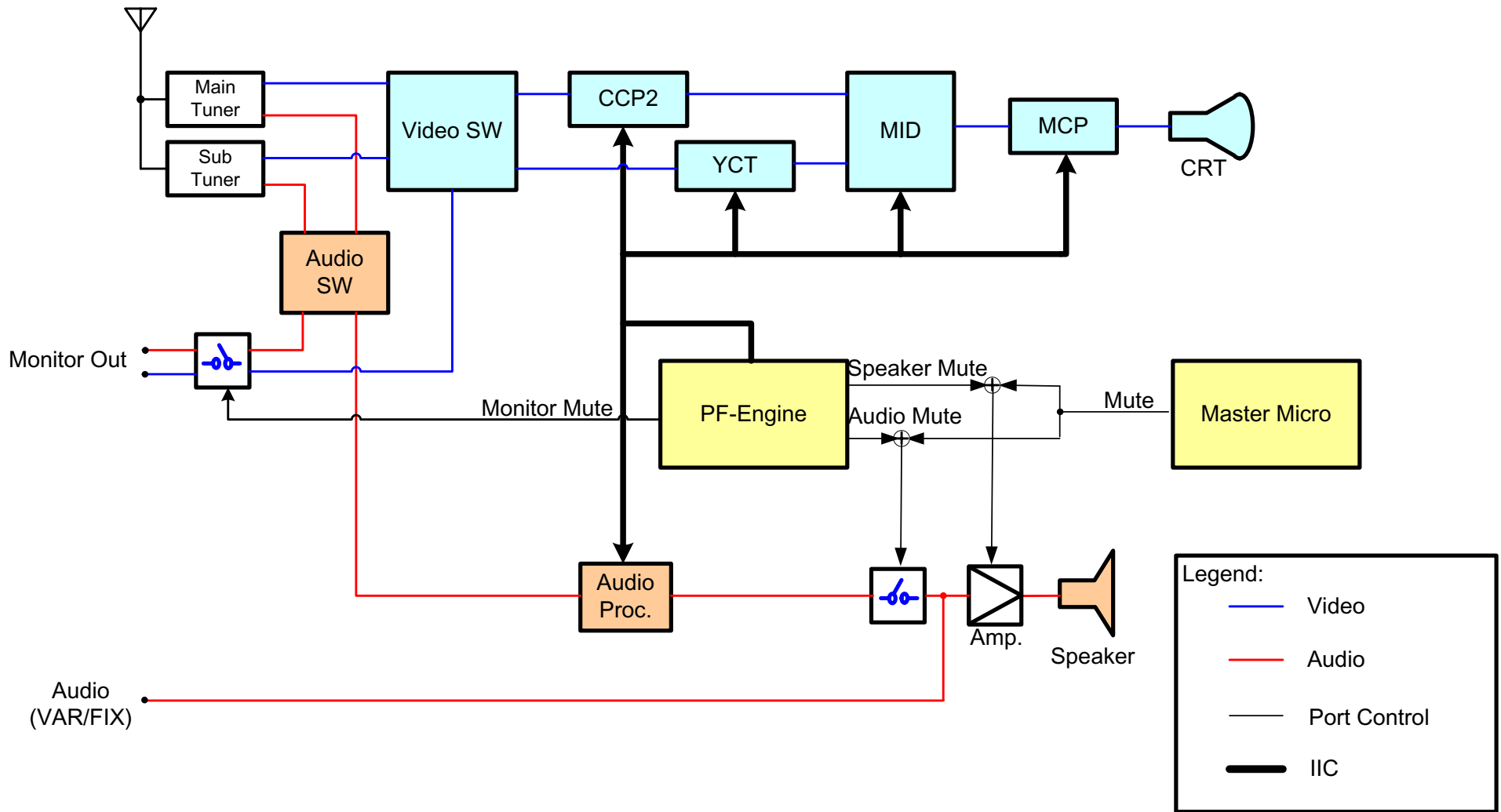

Q MODULE

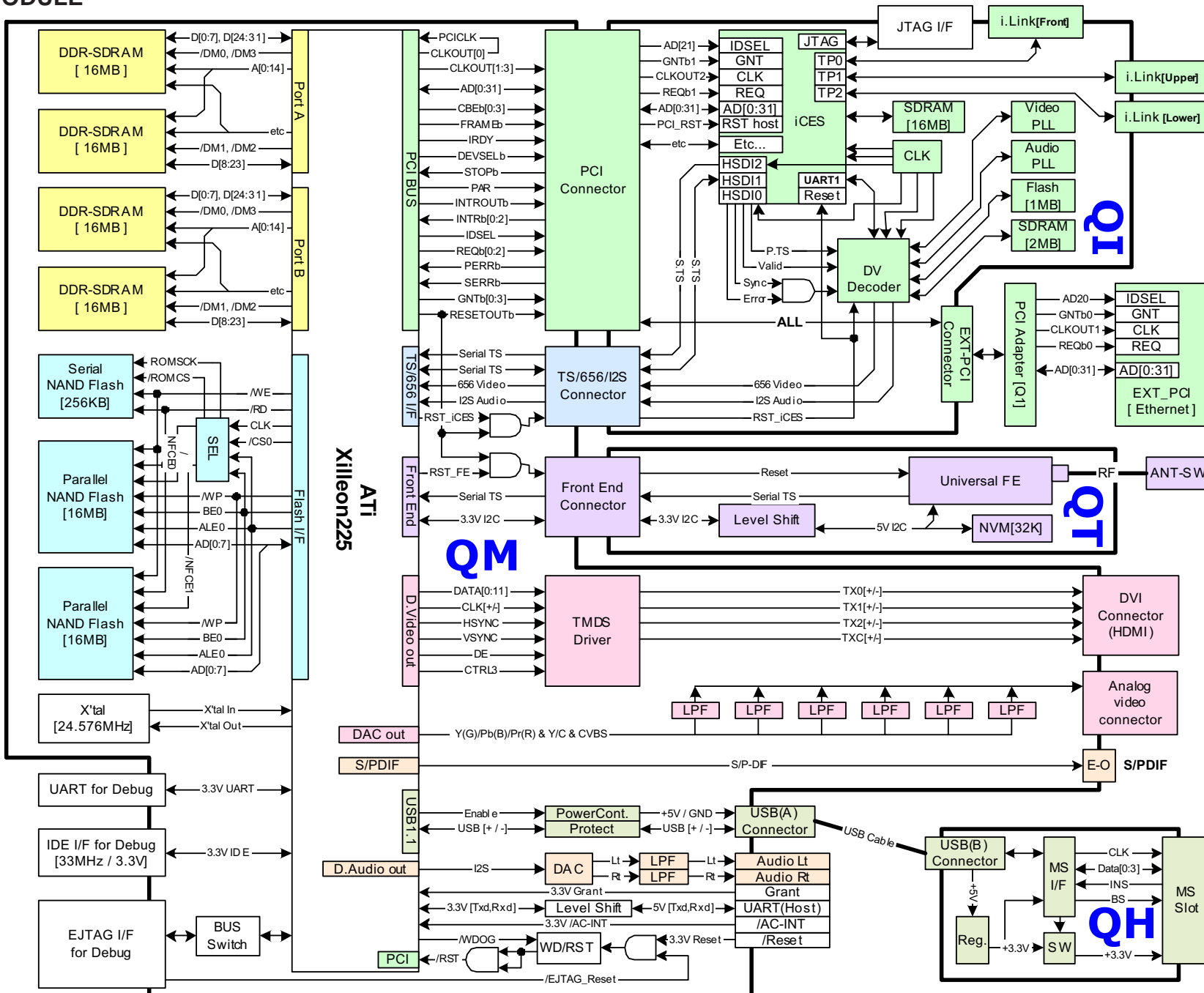

5-4. SCHEMATICS AND SUPPORTING INFORMATION  
CR BOARD SCHEMATIC DIAGRAM

**CR** [R CRT DRIVE]  
COMPONENT SIDE

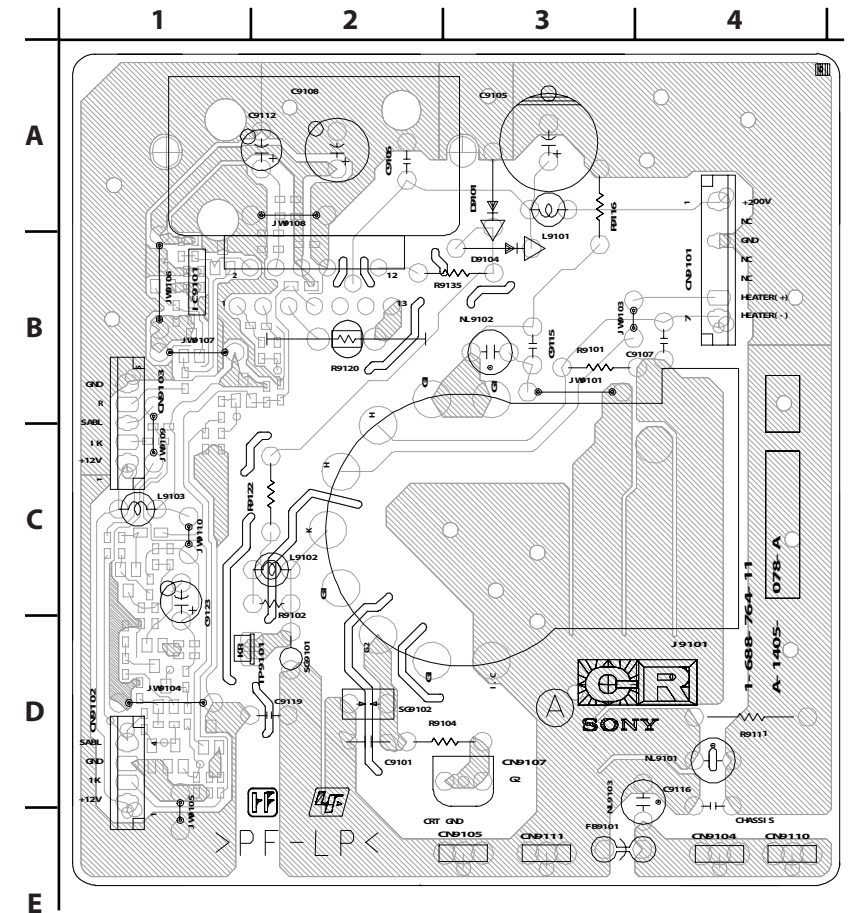
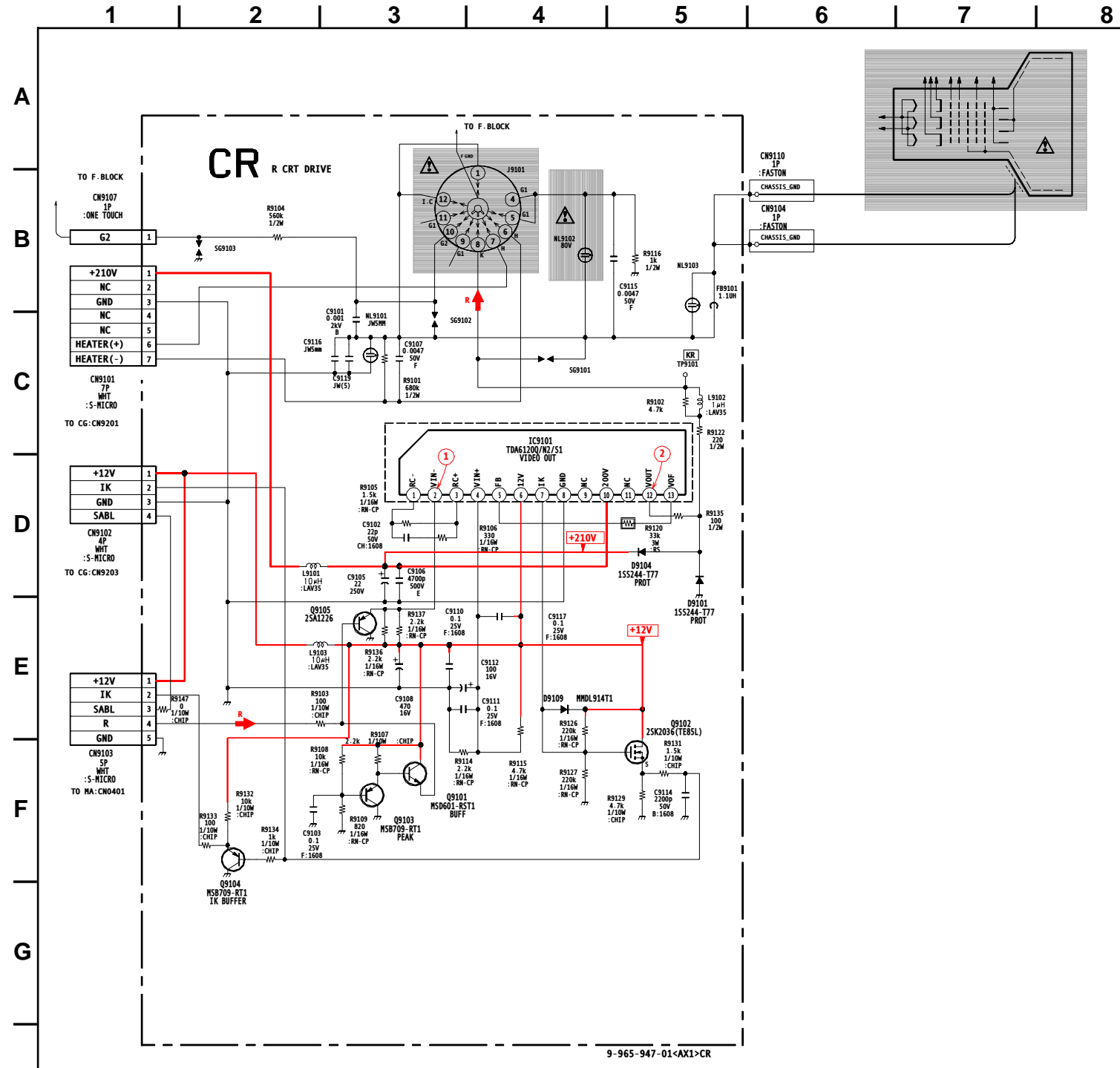

**CR** [R CRT DRIVE]  
CONDUCTOR SIDE

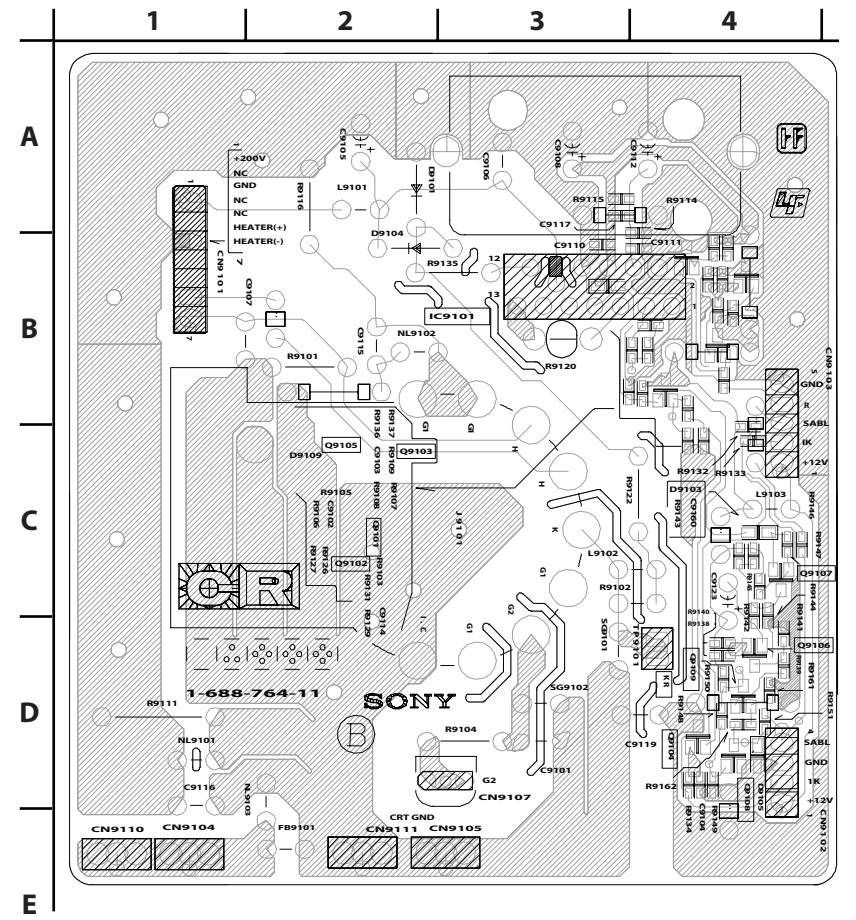

CR BOARD WAVEFORMS

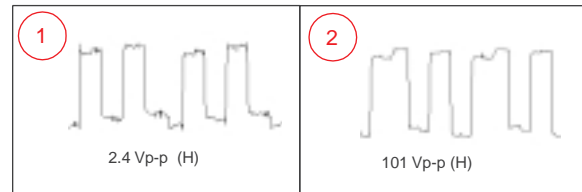

CR BOARD TRANSISTOR VOLTAGE LIST

	B	C	E
Q7101	1.7	GND	2.3
Q7102	2.3	12.0	2.7

	G	D	S
Q7103	7.0	12.0	5.7

All voltages are in V.

CR BOARD IC VOLTAGE LIST

IC7101			
PIN	VOLT	PIN	VOLT
1	2.0	8	GND
2	2.7	9	N/C
3	3.4	10	200.0
4	4.1	11	N/C
5	2.6	12	157.7
6	12.0	13	158.2
7	7.0		

All voltages are in V.



CB BOARD SCHEMATIC DIAGRAM

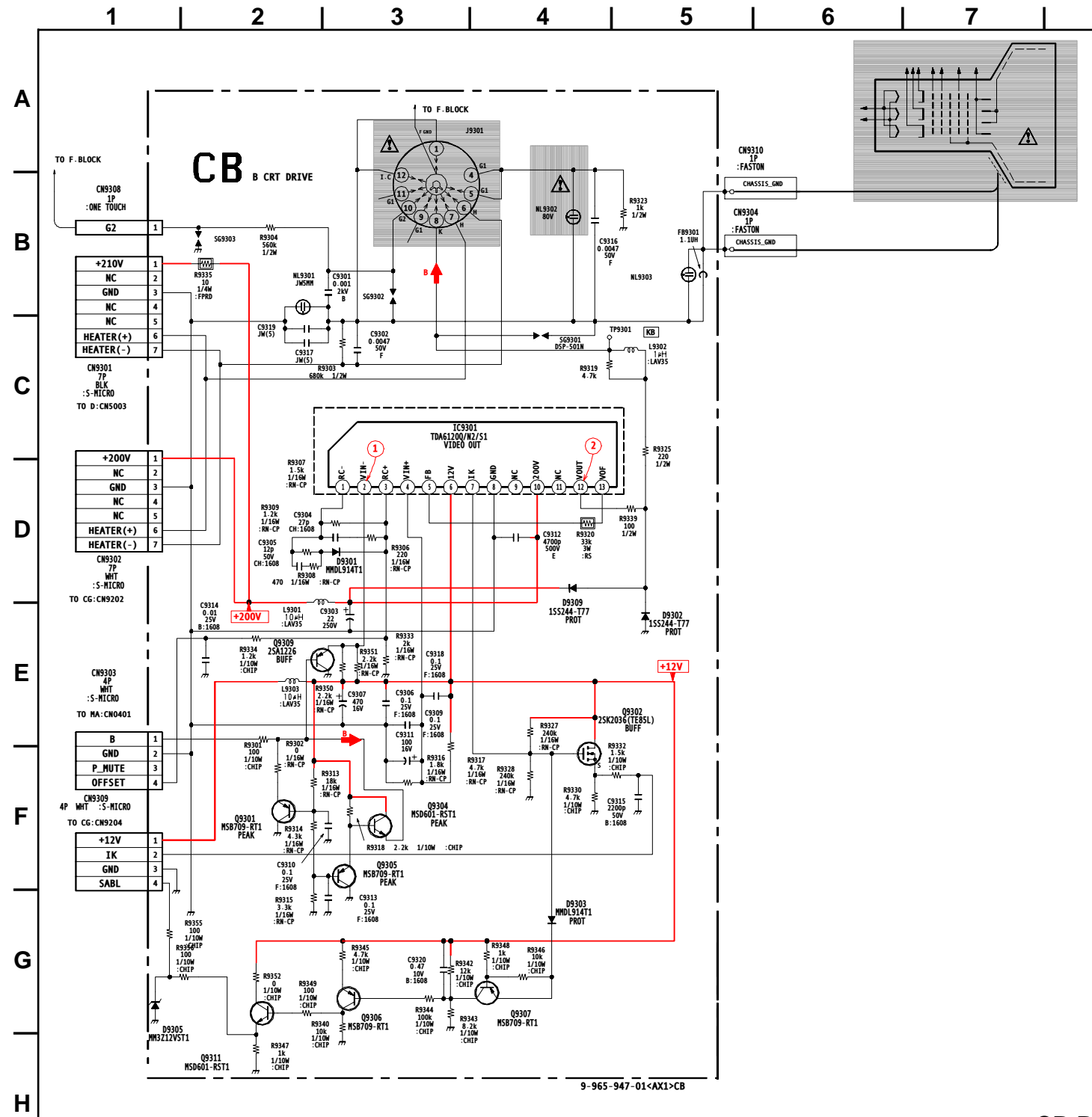

**CB** [B CRT DRIVE] COMPONENT SIDE

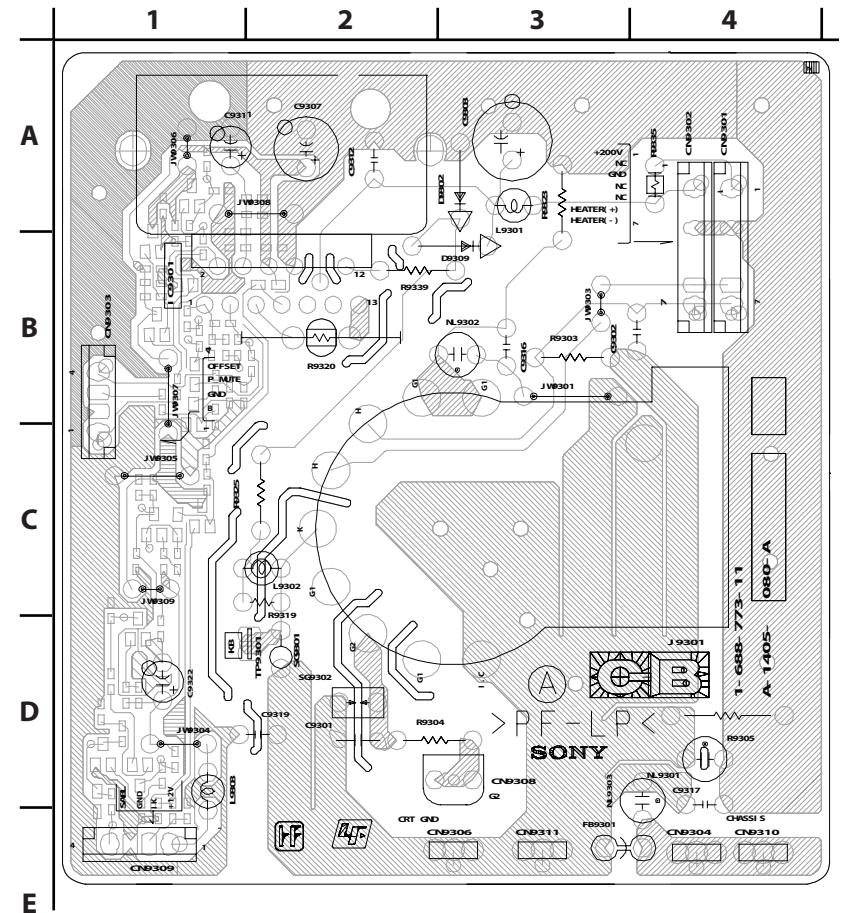

**CB** [B CRT DRIVE] CONDUCTOR SIDE

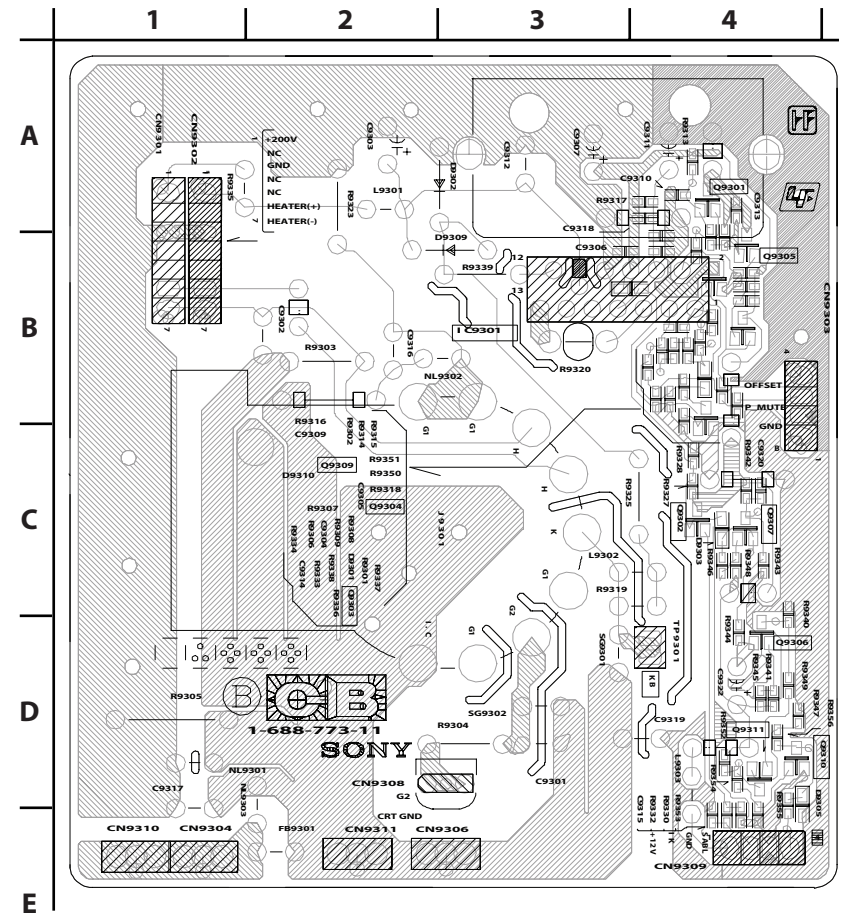

CB BOARD WAVEFORMS

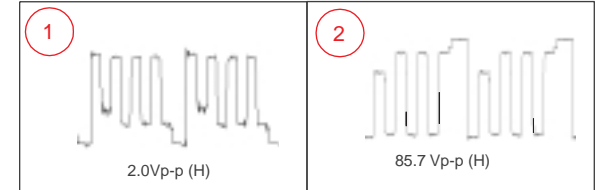

CB BOARD TRANSISTOR VOLTAGE LIST

	B	C	E
Q7301	3.9	GND	3.0
Q7302	1.7	GND	2.4
Q7303	2.4	12.0	2.9
	G	D	S
Q7304	7.3	12.0	6.0

All voltages are in V.

CB BOARD IC VOLTAGE LIST

IC7301			
PIN	VOLT	PIN	VOLT
1	2.1	8	GND
2	2.9	9	N/C
3	1.6	10	200.0
4	2.9	11	N/C
5	2.5	12	161.8
6	12.0	13	144.5
7	7.3		

All voltages are in V.

CG BOARD SCHEMATIC DIAGRAM

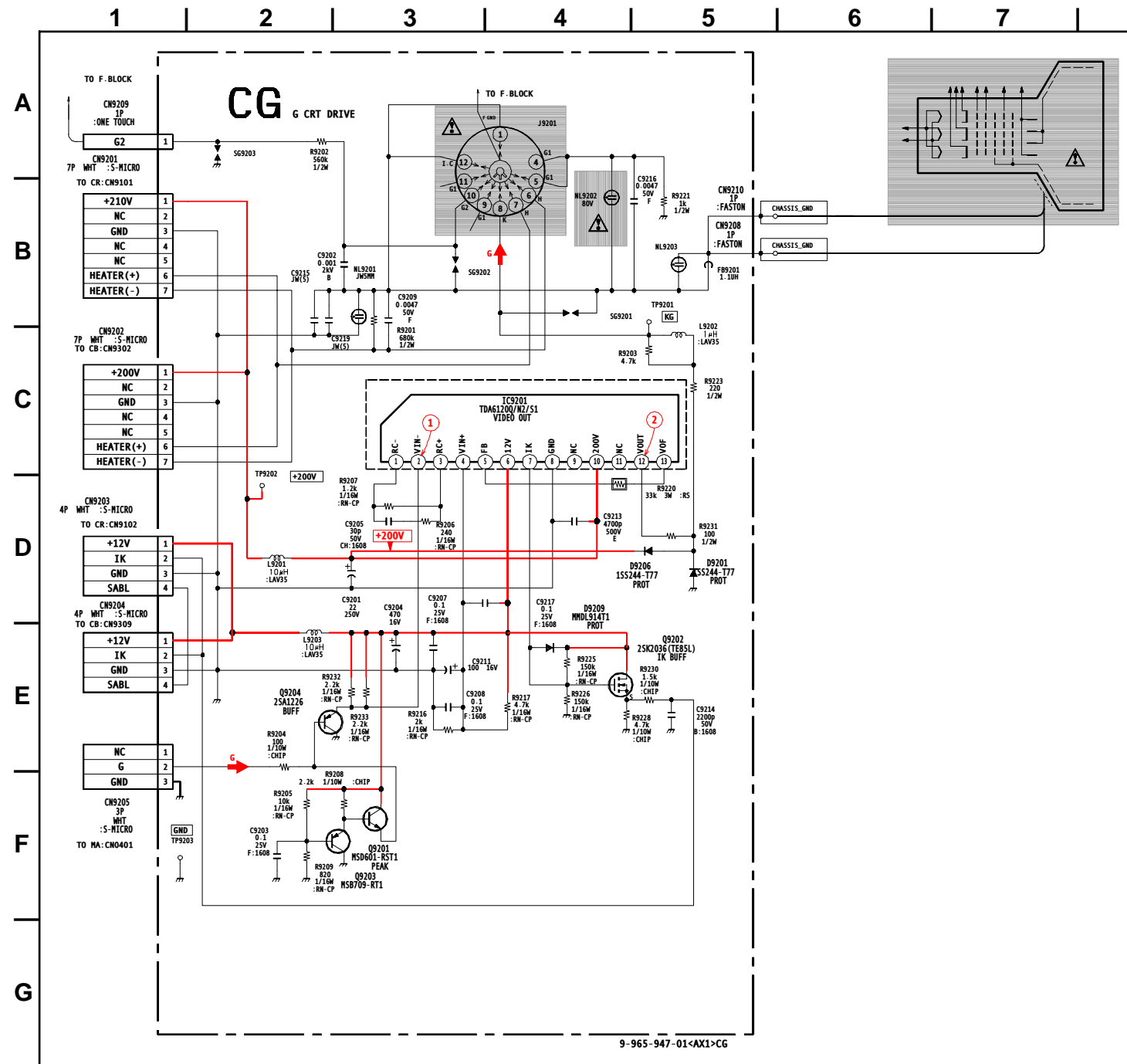

**CG** [G CRT DRIVE]  
COMPONENT SIDE

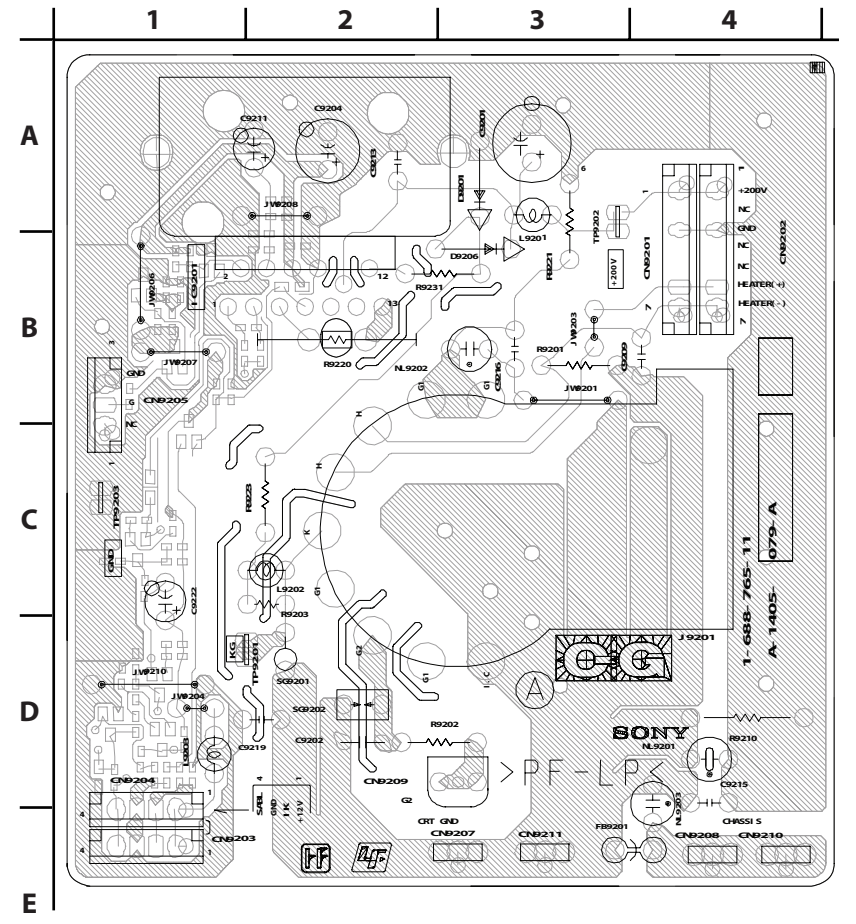

**CG** [G CRT DRIVE]  
CONDUCTOR SIDE

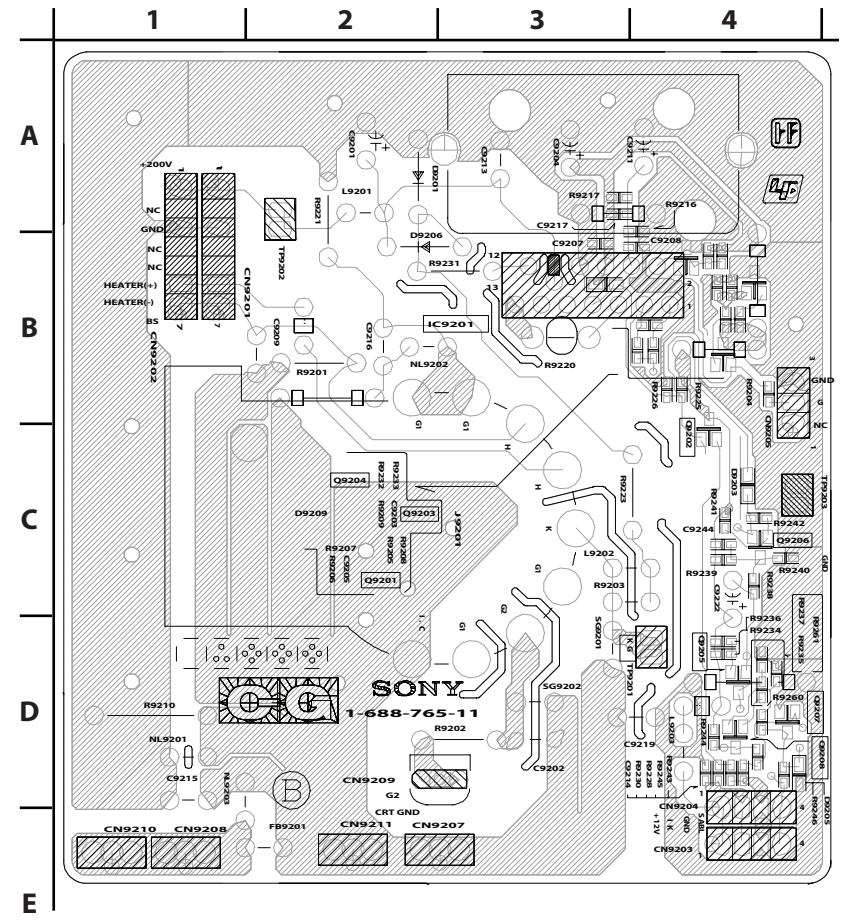

CG BOARD WAVEFORMS

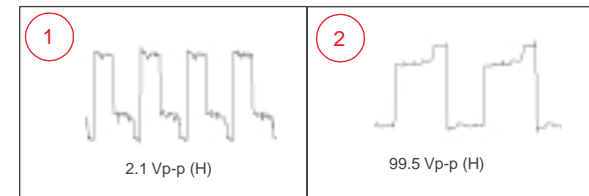

CG BOARD TRANSISTOR VOLTAGE LIST

	B	C	E
Q7201	1.7	GND	2.3
Q7202	2.3	12.0	2.6
	G	D	S
Q7203	7.6	12.0	6.3

All voltages are in V.

CG BOARD IC VOLTAGE LIST

IC7201			
PIN	VOLT	PIN	VOLT
1	1.9	8	GND
2	2.6	9	N/C
3	3.1	10	200.0
4	3.8	11	N/C
5	2.5	12	155.1
6	12.0	13	159.2
7	7.6		

All voltages are in V.

VM BOARD SCHEMATIC DIAGRAM

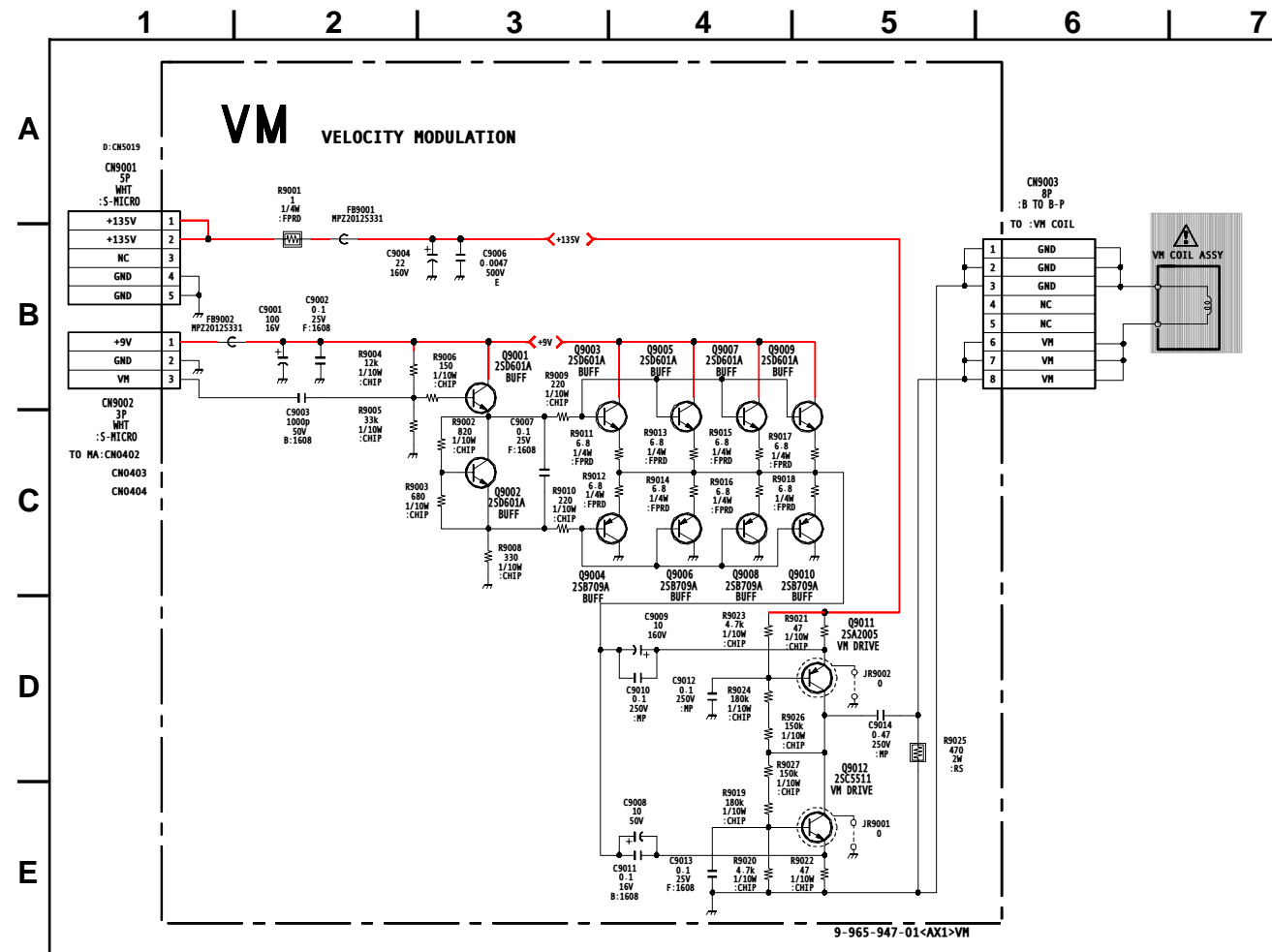

**VM** [VELOCITY MODULATION]  
COMPONENT SIDE

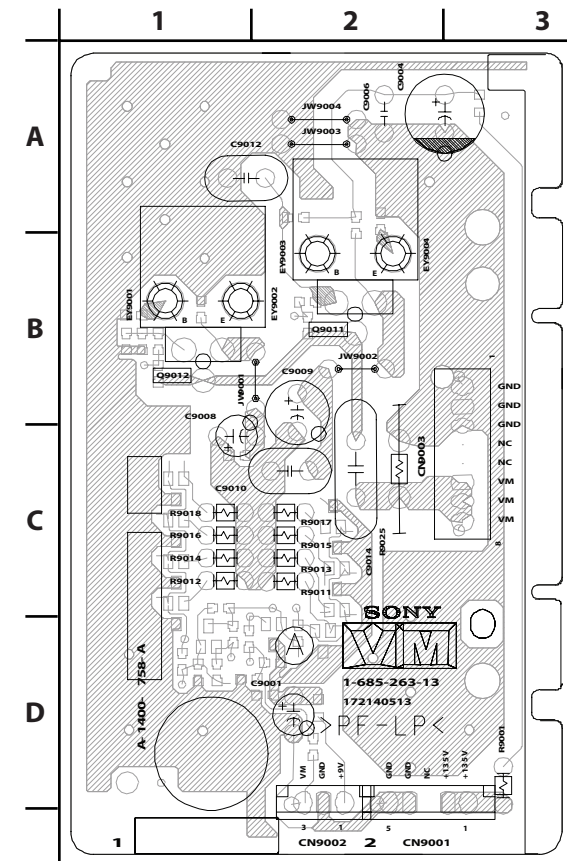

**VM** [VELOCITY MODULATION]  
CONDUCTOR SIDE

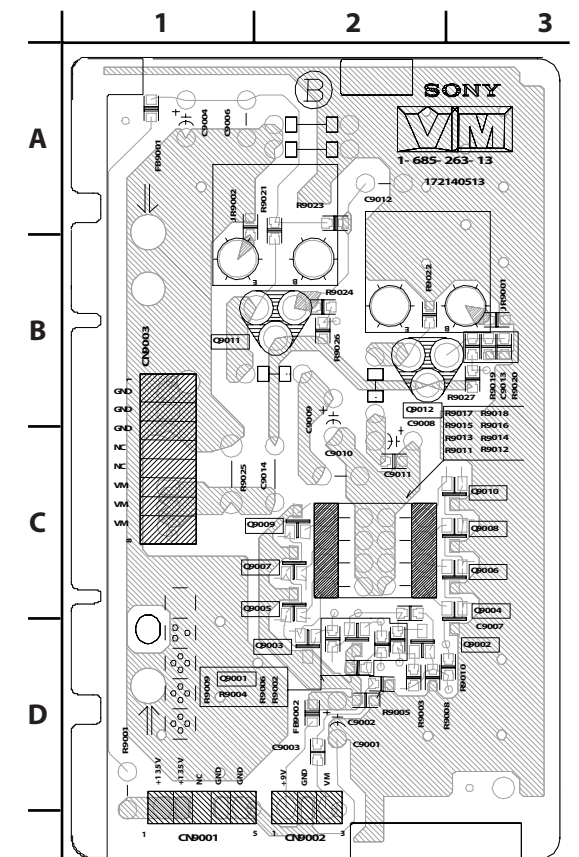

VM BOARD TRANSISTOR VOLTAGE LIST

	B	C	E
Q9001	0.0	9.0	5.2
Q9002	3.6	5.2	4.5
Q9003	5.1	9.0	4.5
Q9004	3.6	GND	4.3
Q9005	5.1	9.0	4.5
Q9006	3.6	GND	4.3
Q9007	5.1	9.0	4.5
Q9008	3.6	GND	4.3
Q9009	5.1	9.0	4.5
Q9010	3.6	GND	4.3
Q9011	133	66.7	134
Q9012	0	66.7	0

All voltages are in V.

MA BOARD SCHEMATIC DIAGRAM (1 OF 3) Due to the complexity of this board, performing component level field repairs is not recommended. If service is required, complete board replacement is the preferred repair method. Data is provided for reference only.

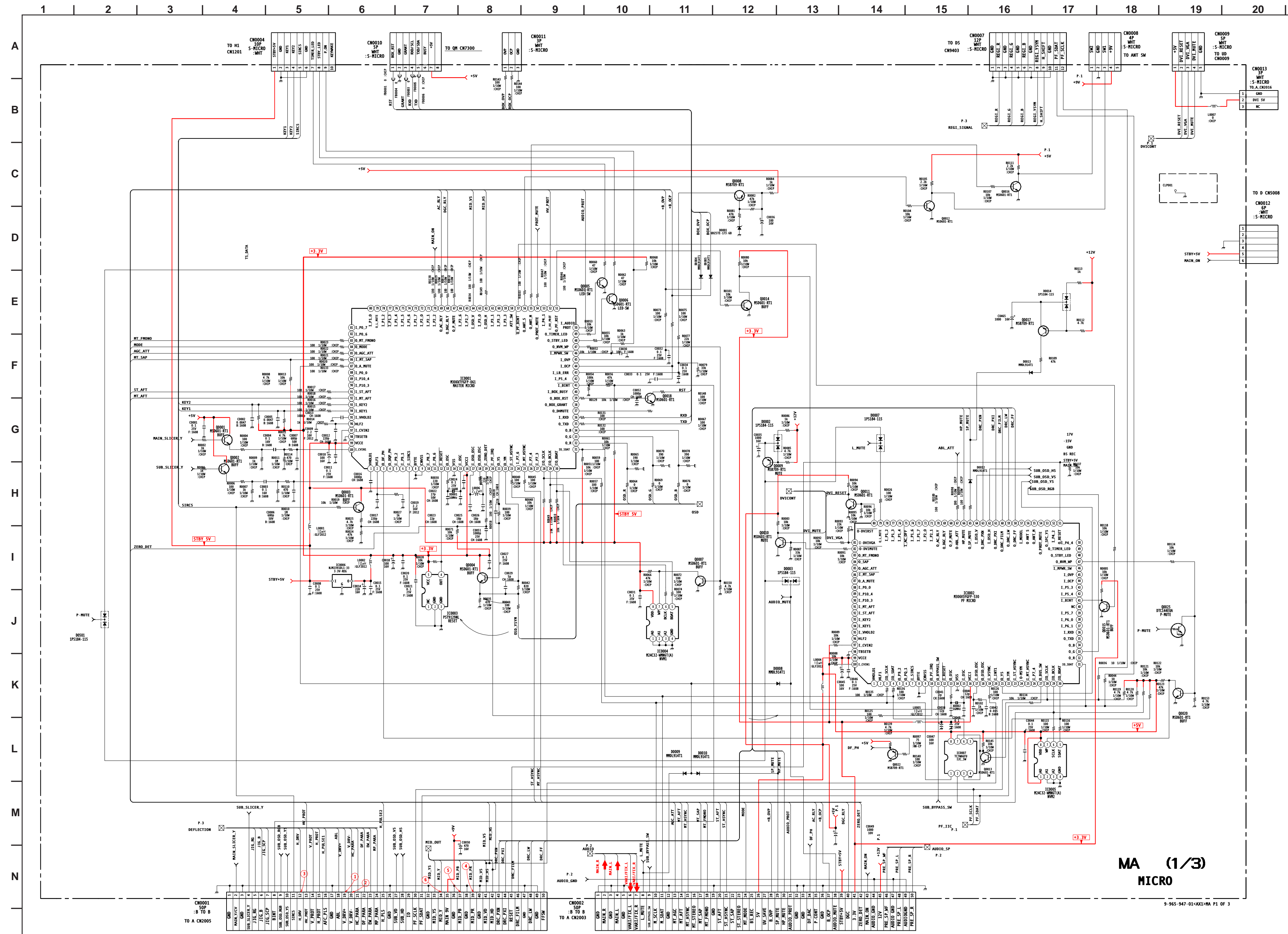

MA BOARD WAVEFORMS

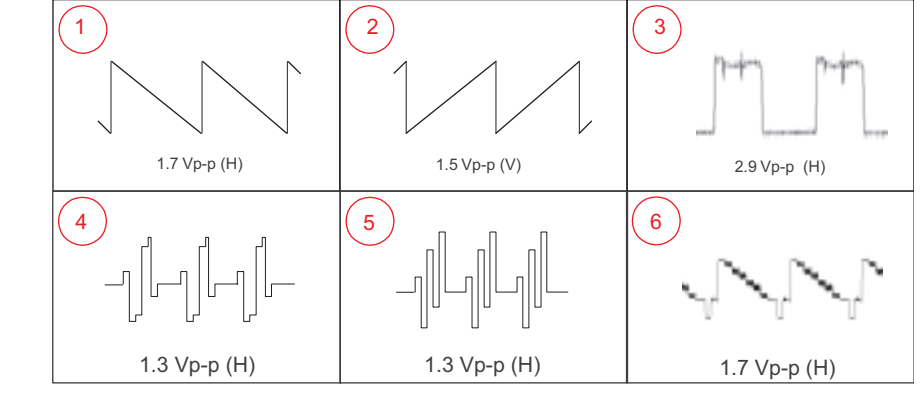

**MA BOARD SCHEMATIC DIAGRAM (2 OF 3)** Due to the complexity of this board, performing component level field repairs is not recommended. If service is required, complete board replacement is the preferred repair method. Data is provided for reference only.

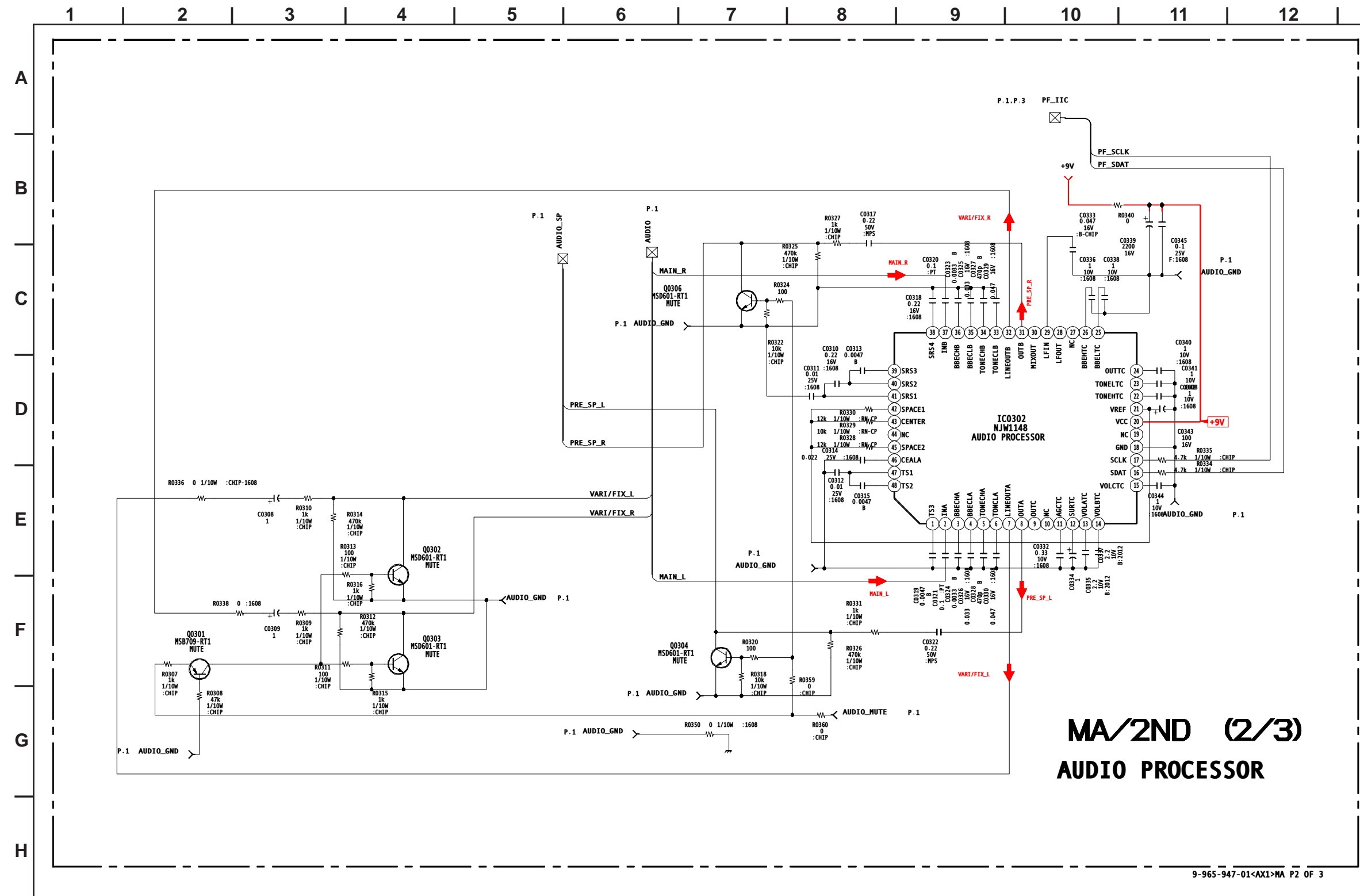

MA BOARD SCHEMATIC DIAGRAM (3 OF 3) Due to the complexity of this board, performing component level field repairs is not recommended. If service is required, complete board replacement is the preferred repair method. Data is provided for reference only.

MA BOARD WAVEFORMS

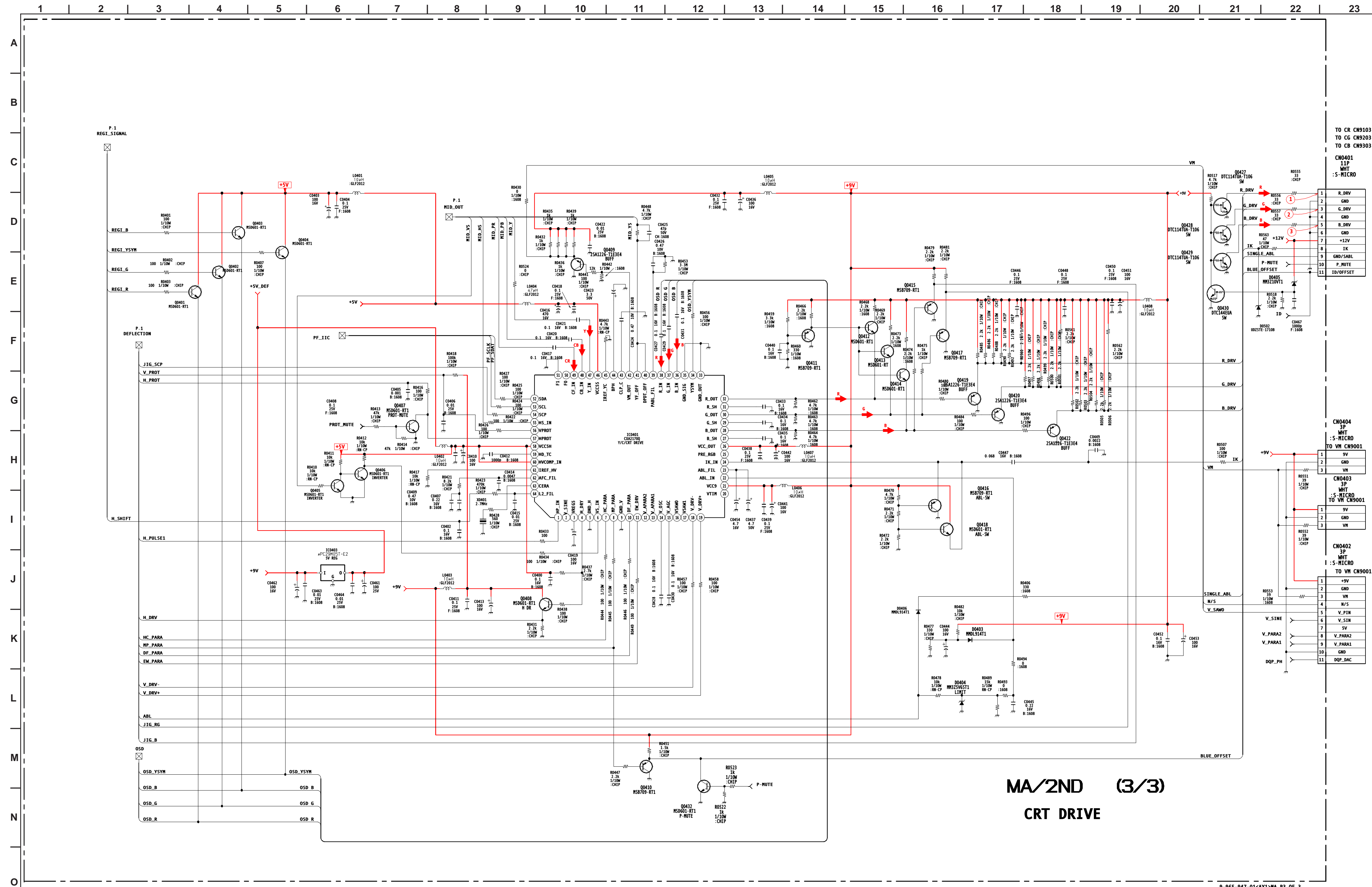
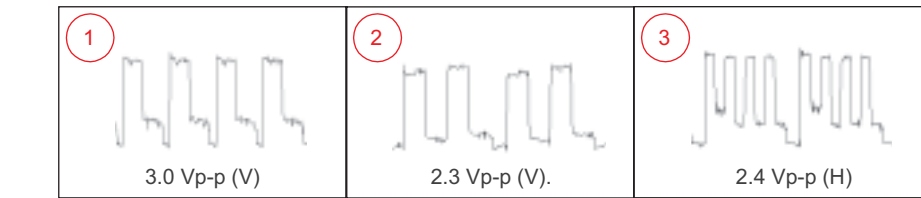

TO CR CN9103  
TO CG CN9203  
TO CB CN9303

1	R_DRV
2	GND
3	G_DRV
4	GND
5	B_DRV
6	GND
7	+12V
8	IK
9	GND/SABL
10	P_MUTE
11	ID/OFFSET

CN0404  
3P  
:S-MICRO  
TO VH CN9001

1	GND
2	VH
3	VH

CN0403  
3P  
:S-MICRO  
TO VH CN9001

1	SV
2	GND
3	VH

CN0402  
3P  
:S-MICRO  
TO VH CN9001

1	+9V
2	GND
3	VH
4	N/S
5	V_PIN
6	V_SIN
7	SV
8	V_PARA2
9	V_PARA1
10	GND
11	DQP_DAC

MA/2ND (3/3)  
CRT DRIVE

**MA** [MICRO, AUDIO PROCESSOR, CRT DRIVE]  
**COMPONENT SIDE**

**MA** [MICRO, AUDIO PROCESSOR, CRT DRIVE]  
**CONDUCTOR SIDE**

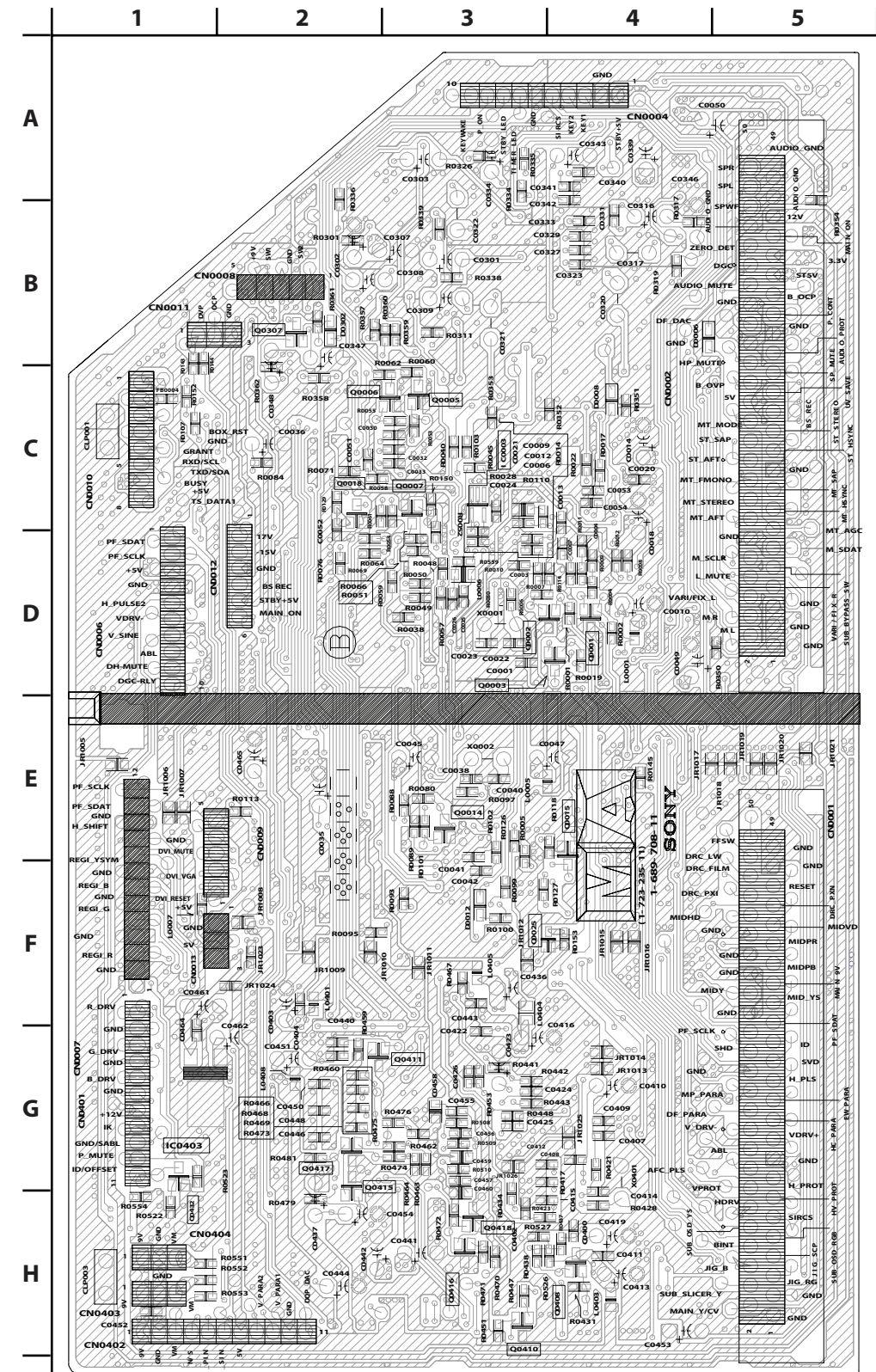
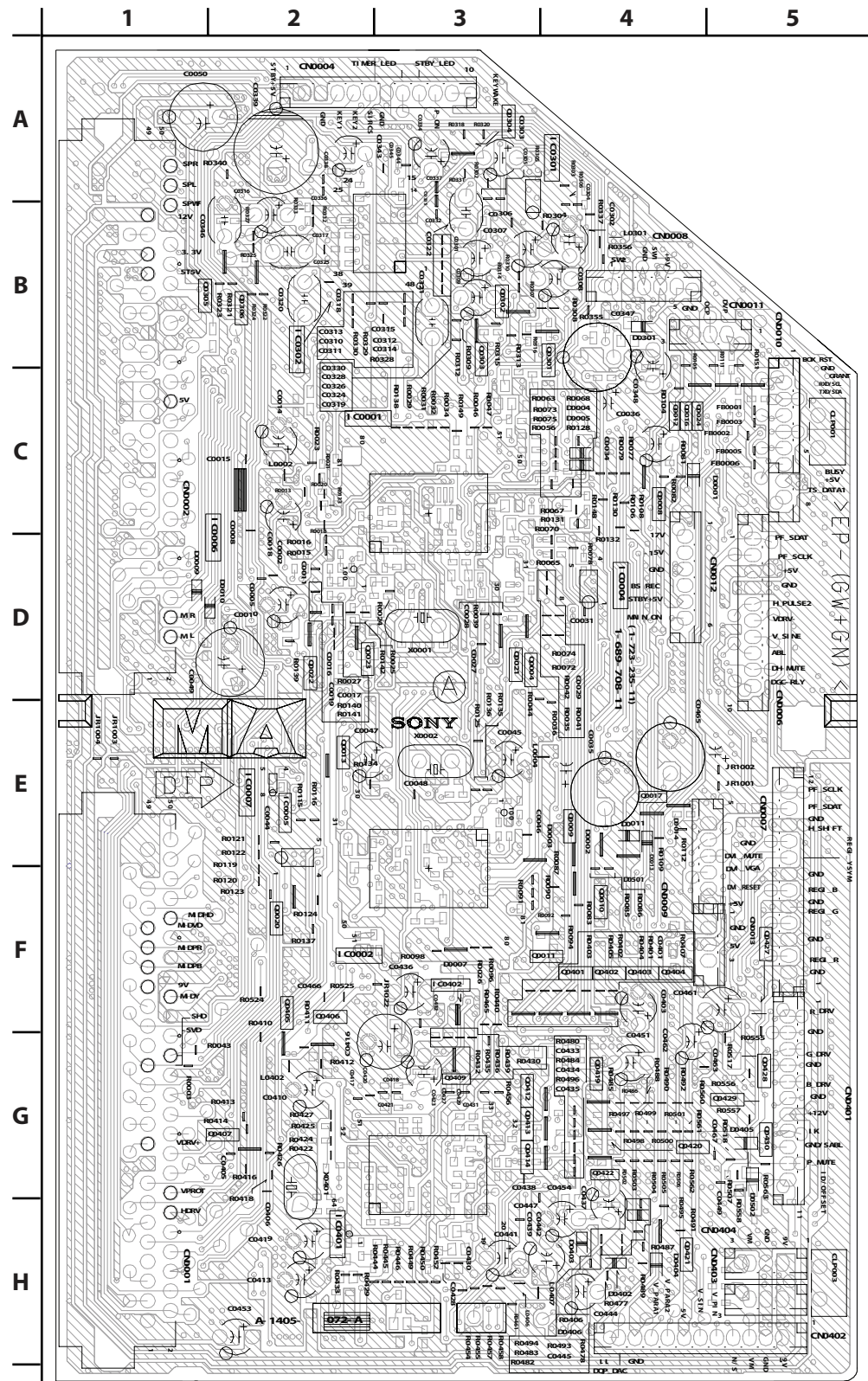

A BOARD SCHEMATIC DIAGRAM (1 OF 2)

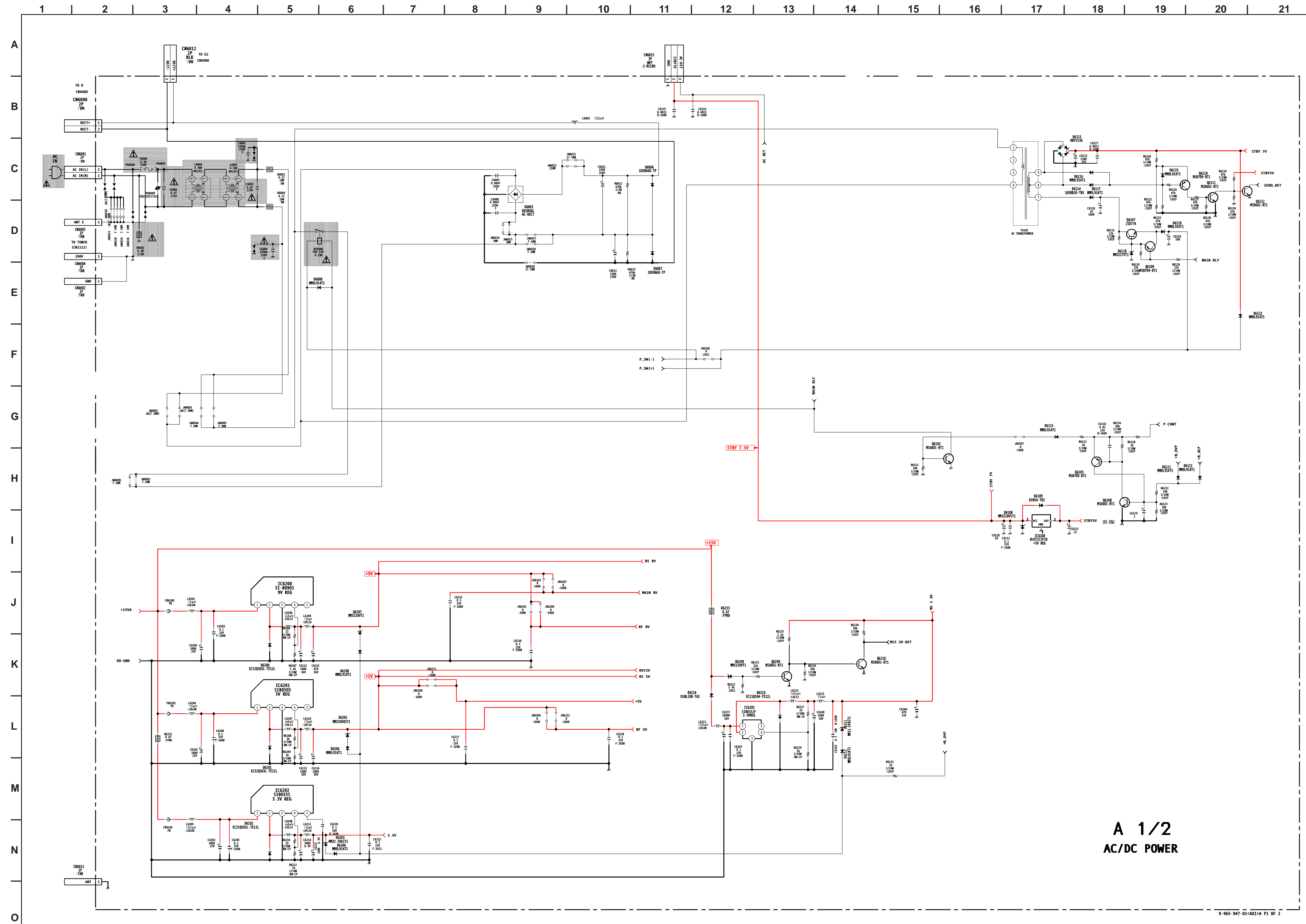

A BOARD IC VOLTAGE LIST

IC2000		IC6100		IC6203	
PIN	VOLT	PIN	VOLT	PIN	VOLT
1	-22.00	1	7.0	1	15.0
2	-22.00	0	5.0	2	3.3
3	0.0	GND	GND	3	GND
4	22.1	IC6200		4	3.3
5	9.1	PIN	VOLT	5	NC
6	5.1	1	15.0	All voltages are in V.	
7	0.0	2	9.0		
8	2.7	3	GND		
9	0.0	4	9.0		
10	0.0	5	NC		
11	0.0	IC6201			
12	5.3	PIN	VOLT		
13	GND	1	15.0		
14	-20.7	2	5.0		
15	0.0	3	GND		
16	-5.5	4	5.0		
17	0.0	5	NC		
18	0.0	IC6202			
19	0.0	PIN	VOLT		
20	0.0	1	15.0		
21	9.3	2	3.3		
22	22.1	3	GND		
23	0.0	4	3.3		
24	-22.0	5	NC		
25	-11.6				

A BOARD TRANSISTOR VOLTAGE LIST

Q	B	C	E
Q2000	2.5	GND	0.0
Q2001	0.0	5.2	GND
Q2005	0.0	9.0	0.0
Q2006	0.0	9.0	GND
Q2007	3.5	0.5	3.3
Q2008	9.0	0.0	9.0
Q2009	0.1	7.5	GND
Q2010	5.9	GND	6.5
Q2011	0.8	0.0	GND
Q2012	3.4	0.0	3.3
Q2013	2.8	GND	3.5
Q6105	2.2	0.0	2.2
Q6107	8.4	41.5	8.4
Q6108	0.0	2.2	GND
Q6109	7.7	8.3	8.3
Q6110	6.4	0.7	6.2
Q6111	0.5	0.8	GND
Q6112	0.8	0.5	GND
Q6209	0.7	0	GND
Q6210	0	3.4	GND

All voltages are in V.

A 1/2  
AC/DC POWER



# A BOARD SCHEMATIC DIAGRAM (2 OF 2)

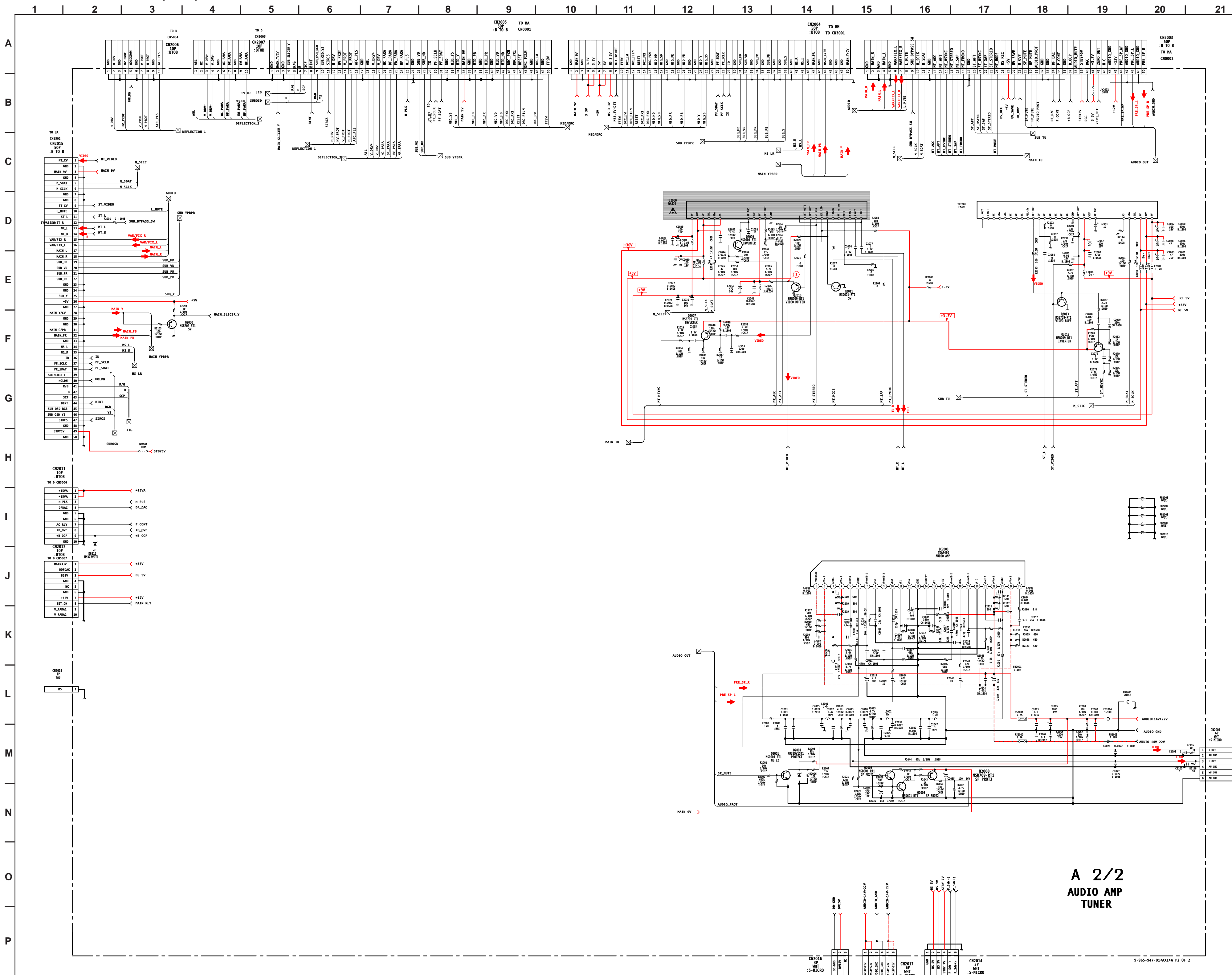

## A BOARD WAVEFORMS

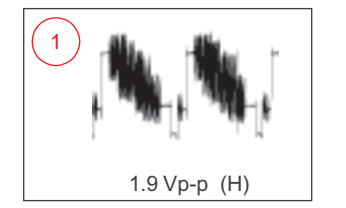

A

[AC/DC POWER, AUDIO AMP TUNER]  
COMPONENT SIDE

1 2 3 4 5 6 7 8 9 10 11 12

A  
B  
C  
D  
E  
F  
G  
H  
I

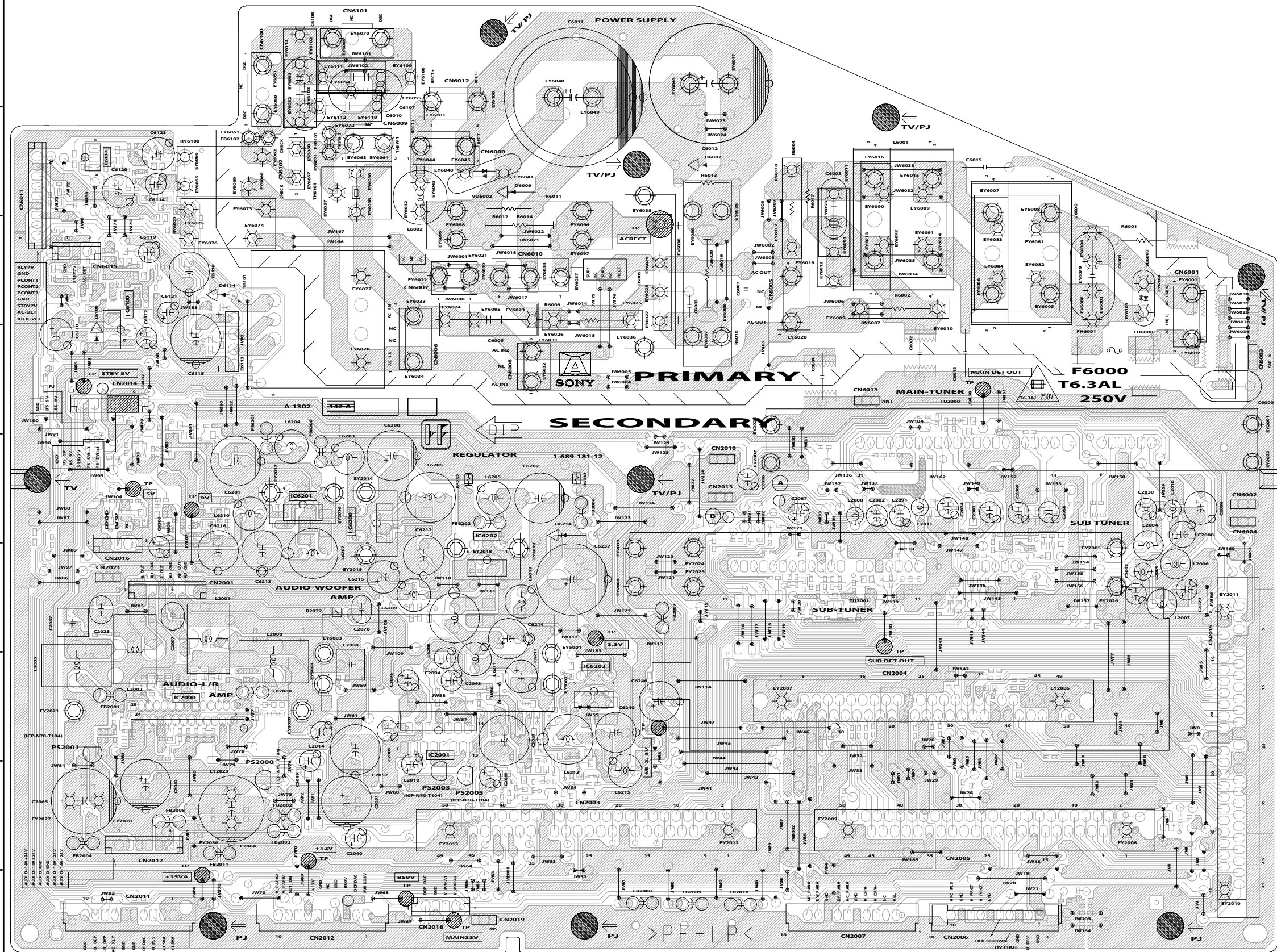

**A**

[AC/DC POWER, AUDIO AMP TUNER]  
**CONDUCTOR SIDE**

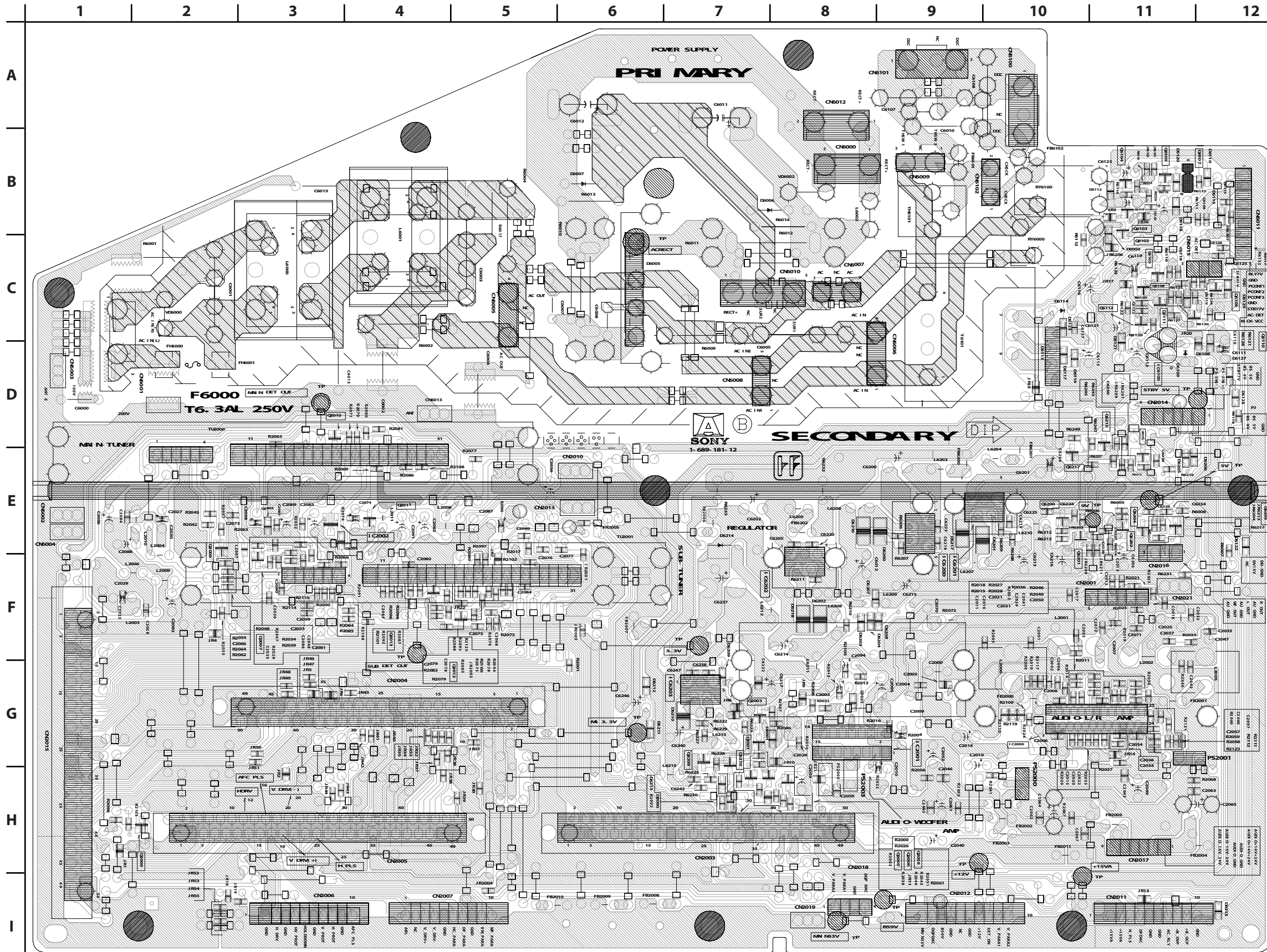

**A BOARD LOCATOR LIST**

DIODE		IC	
D2001	G-7	IC2000	G-10
D6000	C-11	IC6100	C-11
D6005	C-6	IC6200	E-9
D6006	B-7	IC6201	E-9
D6007	B-6	IC6202	E-8
D6108	C-11	IC6203	G-6
D6109	C-11	<b>TRANSISTOR</b>	
D6113	D-10	Q2000	H-1
D6114	C-10	Q2001	G-7
D6115	B-12	Q2005	H-7
D6116	D-10	Q2006	H-7
D6117	D-10	Q2007	E-3
D6118	B-11	Q2008	H-7
D6119	C-12	Q2009	E-2
D6120	B-11	Q2010	D-3
D6121	D-11	Q2011	E-4
D6122	E-12	Q2012	F-5
D6123	C-10	Q2013	F-4
D6125	C-12	Q6102	B-11
D6200	F-8	Q6105	C-11
D6201	E-9	Q6107	B-11
D6202	F-8	Q6108	C-11
D6203	F-8	Q6109	B-11
D6204	F-8	Q6110	C-12
D6205	E-11	Q6111	C-11
D6206	E-12	Q6112	C-11
D6207	F-8	Q6209	G-7
D6208	F-8	Q6210	G-7
D6209	F-7		
D6210	G-6		
D6211	G-6		
D6212	G-6		
D6214	E-7		
D6215	I-12		

All voltages are in V.

UA BOARD SCHEMATIC DIAGRAM (1 OF 2)

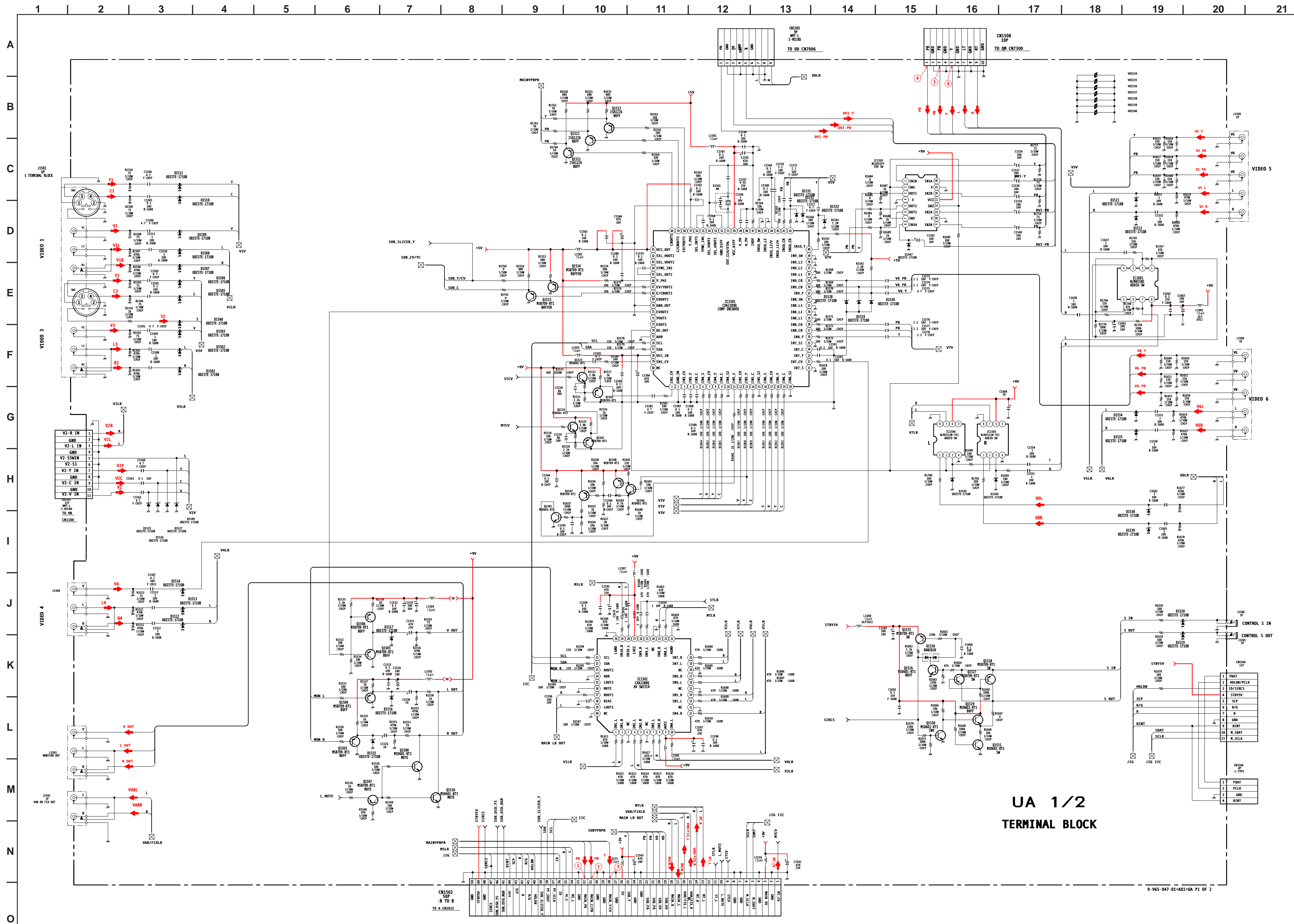

UA BOARD WAVEFORMS

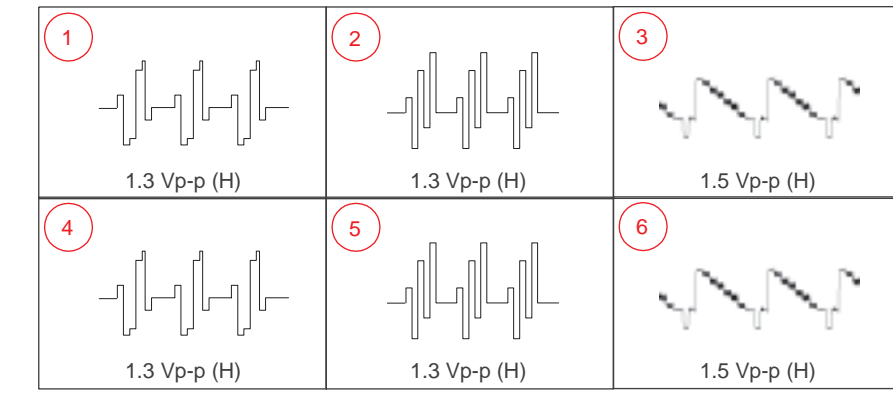

UA BOARD IC VOLTAGE LIST

IC1501				IC1502				IC1503				IC1506				IC1601			
PIN	VOLT			PIN	VOLT			PIN	VOLT			PIN	VOLT			PIN	VOLT		
1	2.4	42	0.0	1	4.5	1	0.0	1	1.0	9	NC	1	4.5						
2	GND	43	0.0	2	GND	2	0.0	2	GND	10	NC	2	0.0						
3	2.0	44	0.0	3	0.0	2	0.0	3	4.8	11	2.3	3	4.5						
4	0.0	45	GND	4	4.5	3	0.0	4	1.0	12	NC	4	0.0						
5	0.0	46	GND	5	4.5	4	GND	5	NC	13	GND	5	4.5						
6	0.0	47	1.1	6	GND	5	0.0	6	4.8	14	NC	6	4.5						
7	2.0	48	0.0	7	4.5	6	0.0	7	0.5	15	0.5	7	0.0						
8	0.0	49	0.0	8	4.5	7	0.0	8	GND	16	NC	8	9.0						
9	0.0	50	5.0	9	9.0	8	0.0	9	1.9	17	2								
10	GND	51	0.0	10	4.5	9	0.0	10	2.6	18	3.1								
11	0.0	52	0.0	11	4.5	10	GND	11	0.9	19	2.0								
12	0.0	53	NC	12	GND	11	4.7	12	2.0	20	0.5								
13	0.0	54	NC	13	4.5	12	0.0	13	GND	21	0.0								
14	2.5	55	0.0	14	4.5	13	0.0	14	GND	22	1.8								
15	0.0	56	0.0	15	GND	14	4.7	15	GND	23	2.1								
16	0.0	57	2.9	16	5.2	15	GND	16	GND	24	2.0								
17	0	58	0.0	17	0.0	16	4.7	17	NC	25	3.4								
18	2.0	59	0.0	18	GND	17	GND	18	GND	26	3.4								
19	0.0	60	2.4	19	4.5	PIN	VOLT	19	5.0	27	3.4								
20	GND	61	5.0	20	4.5	1	5.9	20	NC	28	GND								
21	GND	62	NC	21	GND	2	0.0	21	5.0	29	NC								
22	2.0	63	NC	22	0.0	3	6.0	22	GND	30	NC								
23	2.0	64	2.5	23	0.0	4	GND	23	NC	31	NC								
24	0.0	65	1.1	24	GND	5	NC	24	GND	32	5.0								
25	GND	66	2.9	25	4.5	6	9.0	25	2.4	33	NC								
26	0.0	67	1.3	26	4.5	7	5.2	26	5.0	34	NC								
27	0.0	68	2.4	27	9.0	8	GND	27	2.2	35	NC								
28	2.5	69	2.4	28	4.5	IC1505		28	2.2	36	2.6								
29	GND	70	0.0	29	4.5	PIN	VOLT	29	5.0	37	NC								
30	GND	71	0.0	30	GND	1	5.9	30	GND	38	NC								
31	GND	72	NC	31	4.8	2	0.0	31	GND	39	NC								
32	GND	73	NC	32	4.7	3	6.0	32	1.0	40	1.7								
33	2.0	74	0.0	33	4.5	4	GND	IC1507		41	1.7								
34	2.5	75	0.0	34	GND	5	NC	PIN	VOLT	42	2.4								
35	2.5	76	4.8	35	4.5	6	9.0	1	NC	43	GND								
36	GND	77	4.7	36	GND	7	5.2	2	NC	44	0.0								
37	GND	78	5.0	37	4.5	8	GND	3	4.6	45	3.1								
38	GND	79	2.4	38	4.5			4	4.6	46	2.8								
39	GND	80	NC	39	4.5			5	GND	47	5.0								
								6	2.8	48	3.1								

UA BOARD TRANSISTOR VOLTAGE LIST

	B	C	E		B	C	E
Q1501	2.0	GND	2.7	Q1536	1.9	5.0	1.2
Q1502	3.3	GND	4.0	Q1537	3.2	5.0	2.6
Q1503	4.5	GND	4.0	Q1538	1.9	GND	0.0
Q1504	4.5	GND	5.2	Q1539	1.9	5.0	1.2
Q1505	1.6	GND	0.9	Q1540	2.7	5.0	0.0
Q1506	4.4	8.3	3.8	Q1541	1.9	5.0	0.0
Q1507	0.0	0.0	0.0	Q1542	1.2	GND	1.9
Q1508	0.0	0.0	GND	Q1543	2.1	5.0	1.5
Q1510	0.0	0.0	GND	Q1544	0.7	GND	1.3
Q1511	0.0	GND	3.0	Q1545	0.0	0.0	GND
Q1512	2.0	GND	3.1	Q1546	0.0	8.8	0.0
Q1513	1.5	GND	2.3	Q1547	0.0	0.0	9.0
Q1514	1.2	GND	1.9	Q1548	8.8	9.0	9.0
Q1515	2.3	GND	3.0				
Q1523	4.5	9.0	3.9				
Q1524	6.5	9.0	3.9				
Q1525	4.9	4.2	5.0				
Q1526	0.0	4.9	GND				
Q1527	5.0	0.0	0.0				
Q1528	5.0	0.0	0.0				
Q1529	0.1	5.0	0.0				
Q1530	0.6	0.1	GND				
Q1531	0.6	0.0	GND				
Q1535	2.7	5.0	2.1				

UA 1/2  
TERMINAL BLOCK

### UA BOARD SCHEMATIC DIAGRAM (2 OF 2)

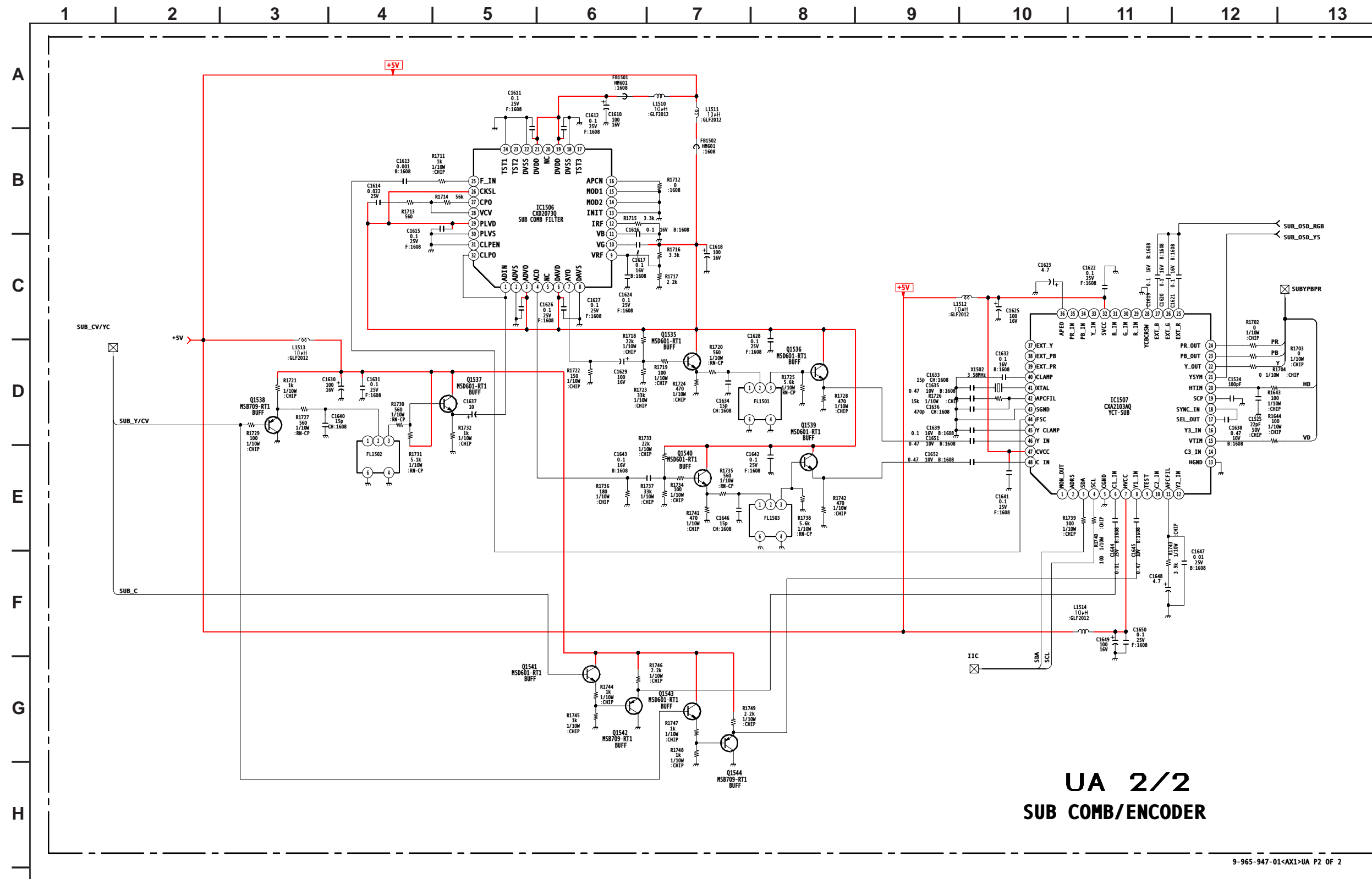

**UA 2/2  
SUB COMB/ENCODER**

9-965-947-01<AX1>UA P2 OF 2

**UA** [TERMINAL BLOCK, SUB COMB/ENCODER]  
**COMPONENT SIDE**

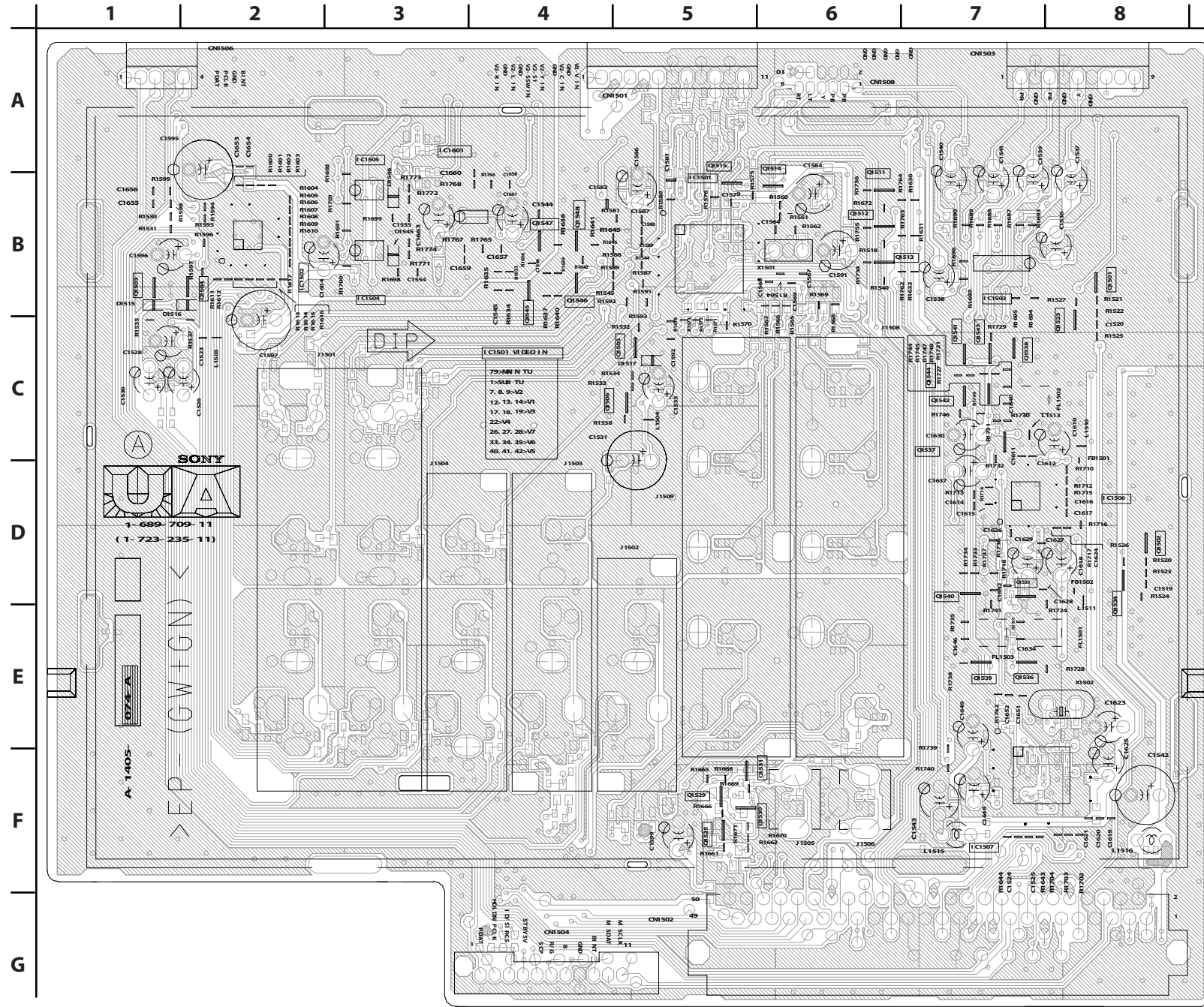

**UA BOARD LOCATOR LIST**

DIODE		TRANSISTOR	
D1515	B-1	Q1501	B-8
D1516	B-1	Q1502	D-8
D1517	C-5	Q1503	B-1
D1545	B-3	Q1504	B-2
D1546	B-3	Q1505	C-5
IC		Q1506	C-5
IC1501	B-5	Q1511	B-6
IC1502	B-3	Q1512	B-6
IC1503	B-7	Q1513	B-6
IC1504	B-3	Q1514	A-6
IC1505	B-3	Q1515	A-5
IC1506	D-7	Q1523	C-8
IC1507	F-7	Q1524	D-8
IC1601	A-3	Q1525	F-5
		Q1529	F-5
		Q1530	F-5
		Q1531	F-5
		Q1535	D-7
		Q1536	E-7
		Q1537	C-7
		Q1538	C-7
		Q1539	E-7
		Q1540	D-7
		Q1541	C-7
		Q1542	C-7
		Q1543	C-7
		Q1544	C-7
		Q1545	B-4
		Q1546	B-4
		Q1547	B-4
		Q1548	B-4

**UA** [TERMINAL BLOCK, SUB COMB/ENCODER]  
**CONDUCTOR SIDE**

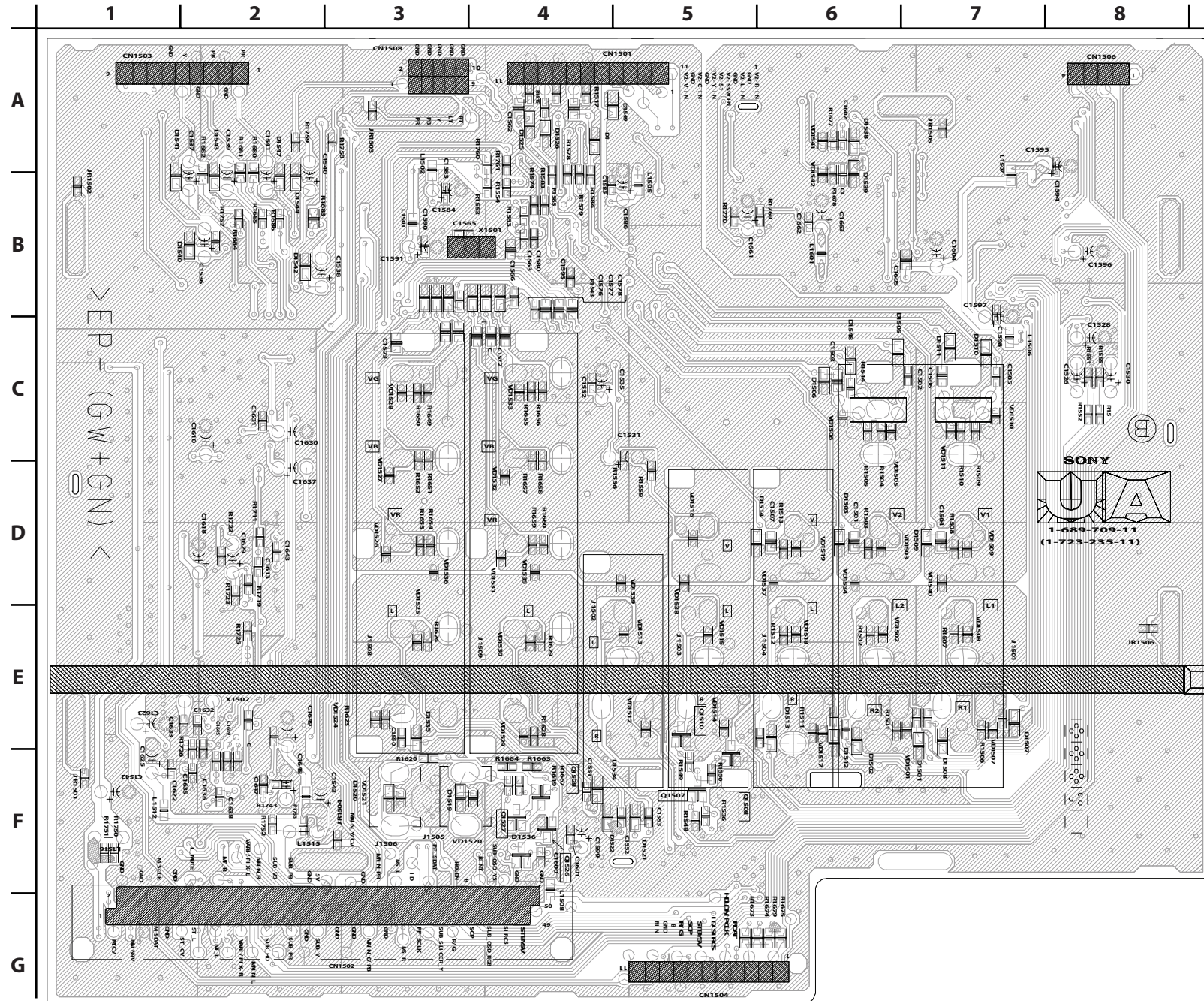

**UA BOARD LOCATOR LIST**

DIODE		DIODE		TRANSISTOR	
D1501	F-7	D1530	B-3	Q1507	F-5
D1502	F-6	D1531	B-3	Q1508	F-5
D1503	D-6	D1532	B-4	Q1510	E-5
D1505	B-6	D1533	B-4	Q1526	F-4
D1506	C-6	D1534	F-4	Q1527	F-4
D1507	E-7	D1535	E-3	Q1528	F-5
D1508	E-7	D1536	F-4		
D1509	D-6	D1538	A-6		
D1510	C-7	D1539	B-6		
D1511	C-7	D1547	A-2		
D1512	F-6	D1548	C-6		
D1513	E-6	D1549	A-5		
D1514	D-6				
D1519	F-3				
D1520	F-3				
D1521	F-5				
D1522	F-5				
D1525	A-4				
D1526	A-4				
D1527	A-4				
D1528	B-3				
D1529	B-3				

AD BOARD SCHEMATIC DIAGRAM

Due to the complexity of this board, performing component level field repairs is not recommended. If service is required, complete board replacement is the preferred repair method. Data is provided for reference only.

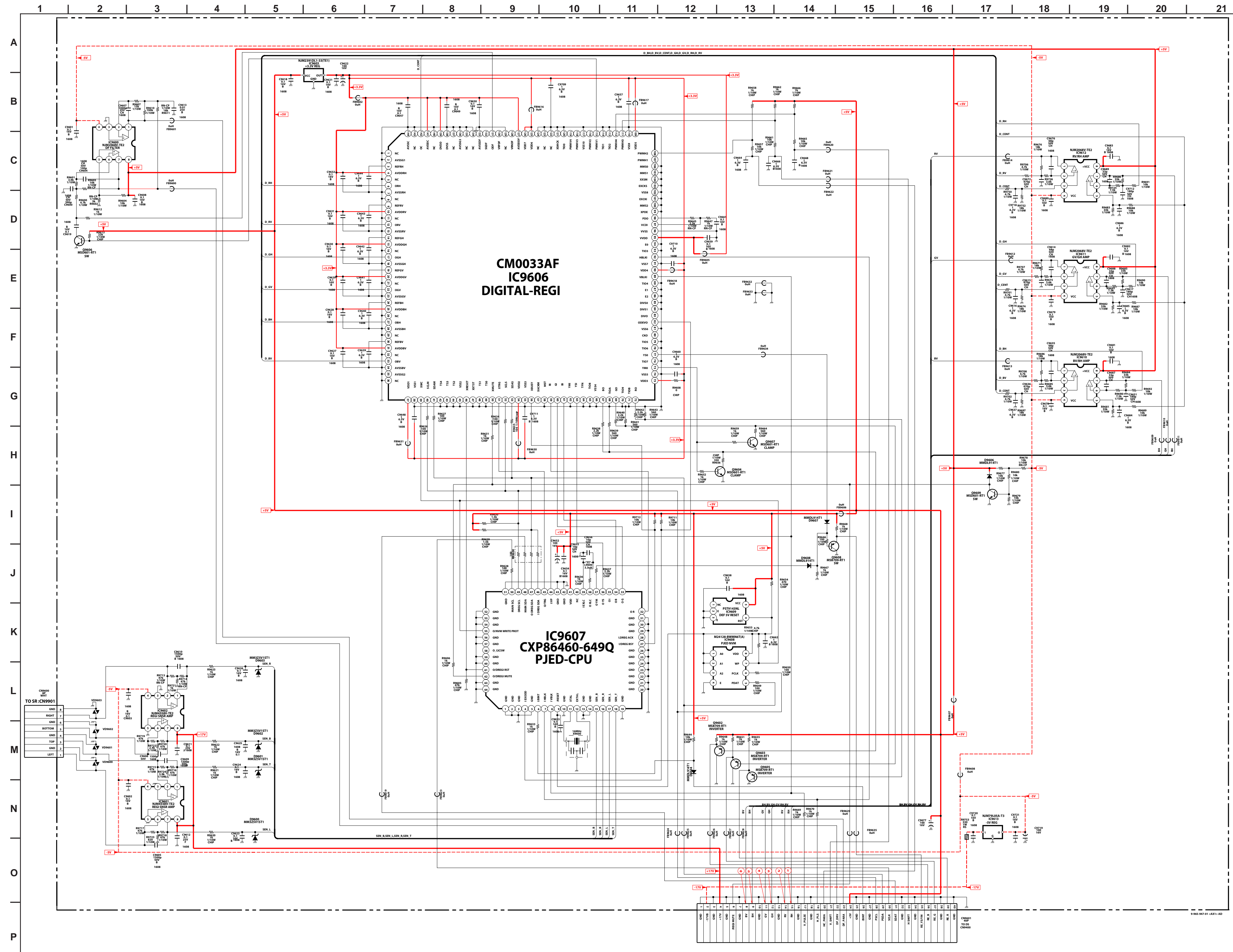

AD BOARD WAVEFORMS

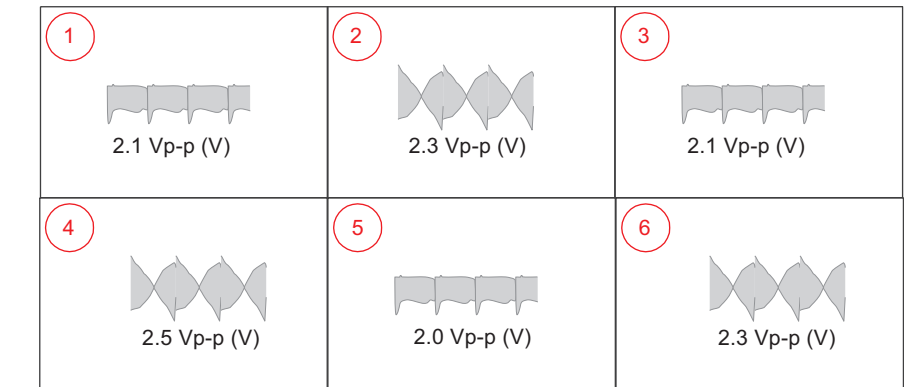





[DIGITAL REGI, PJED CPU]  
**COMPONENT SIDE**

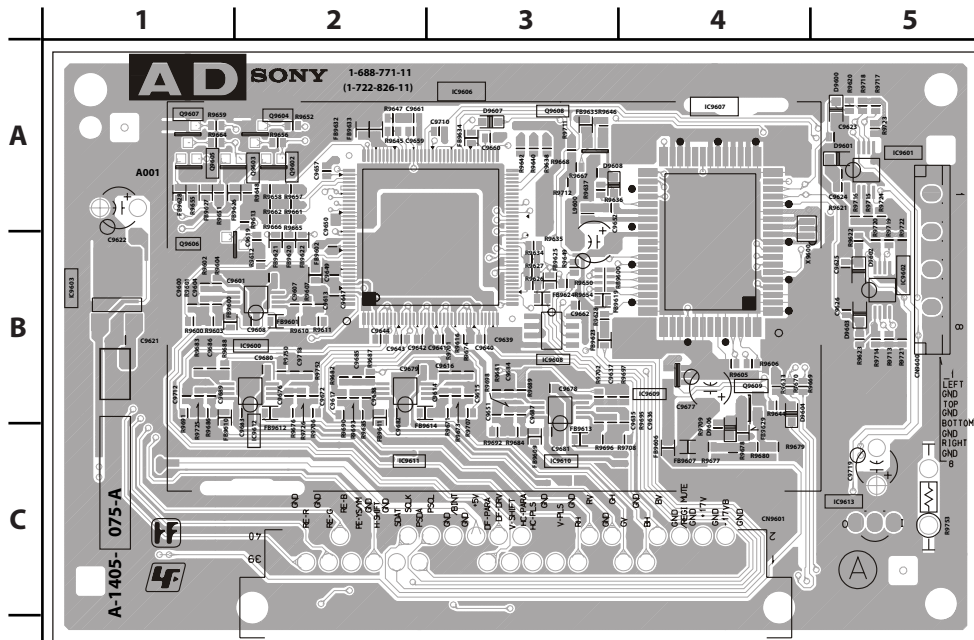

[DIGITAL REGI, PJED CPU]  
**CONDUCTOR SIDE**

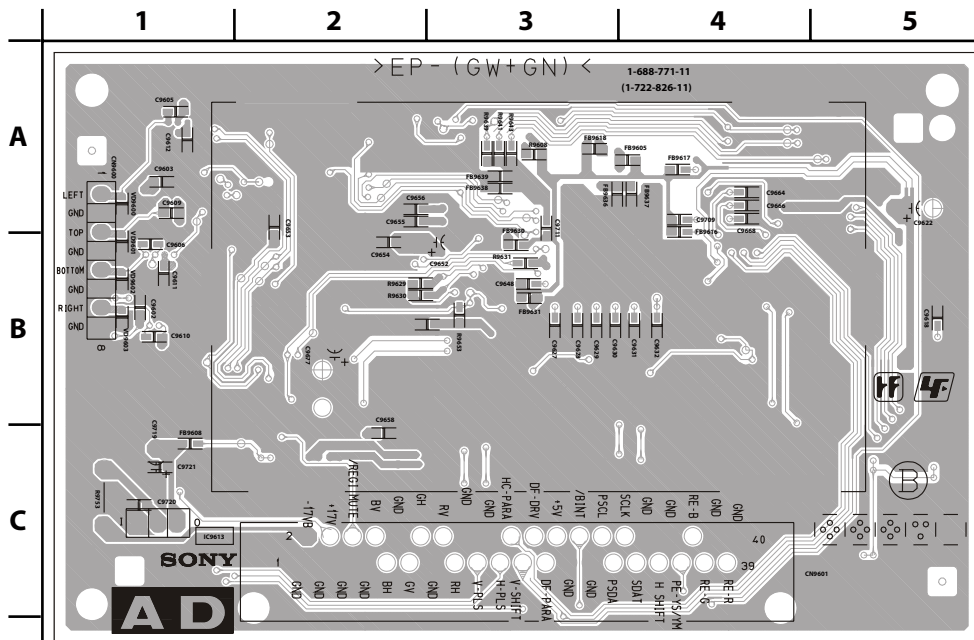

D BOARD SCHEMATIC DIAGRAM (1 OF 3)

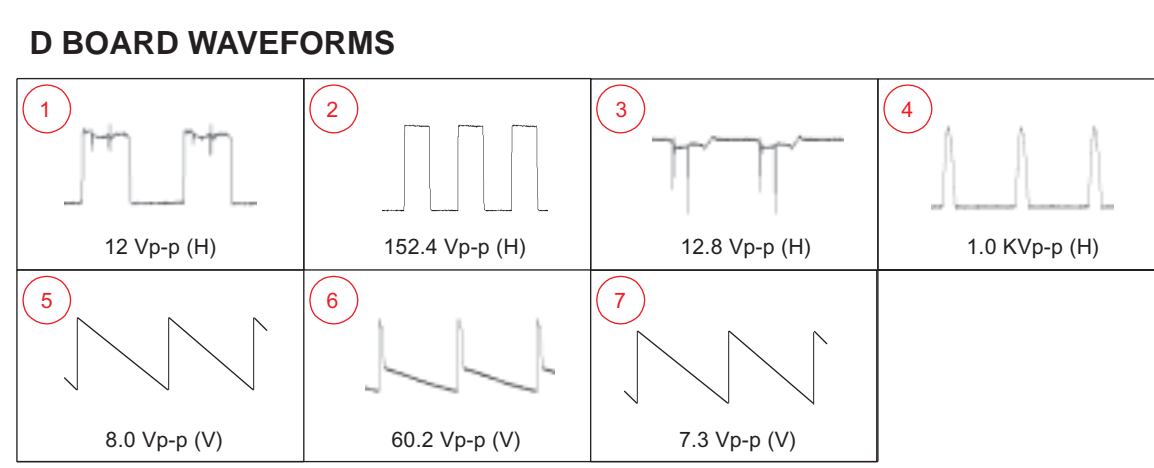
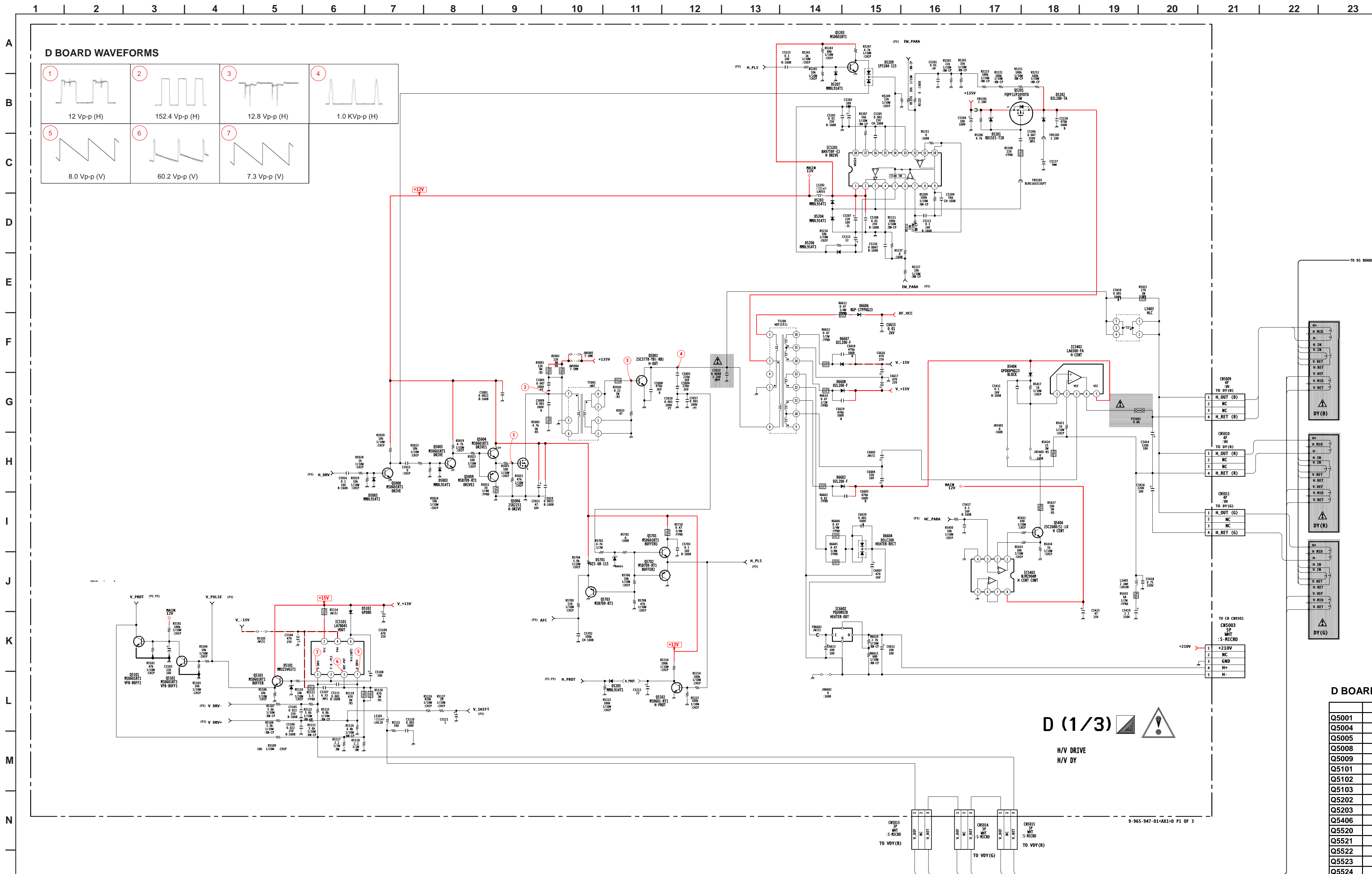

D BOARD IC VOLTAGE LIST

IC5101		IC5403		IC6503		IC8002		IC8006		
PIN	VOLT	PIN	VOLT	PIN	VOLT	PIN	VOLT	PIN	VOLT	
1	1.2	1	2.7	1	134.0	1	2.8	1	N/C	
2	15.0	2	2.1	2	N/C	2	1.8	2	GND	
3	-13.1	3	2.1	3	N/C	3	2.2	3	GND	
4	-15.0	4	GND	4	N/C	4	2.5	4	GND	
5	0.0	5	GND	5	2.5	5	GND	5	7.5	
6	14.6	6	0.0	6	1	6	0.0	6	4.5	
7	1.2	7	0.0	7	GND	7	4.6	7	14.8	
8	12.0	8	12.0	8	12	8	17.9	8	15.0	
IC5201		IC6400		IC6602		IC8001		IC8104		
PIN	VOLT	PIN	VOLT	PIN	VOLT	PIN	VOLT	PIN	VOLT	
1	12.0	1	2.8	1	7.7	10	10.5	1	2.5	
2	12.0	2	1.8	2	6.3	11	GND	2	GND	
3	5.8	3	2.2	3	GND	12	4.8	2	GND	
4	GND	4	2.2	4	GND	13	N/C	3	2.5	
5	7.9	5	2.5	5	14.2	14	151.8			
6	3.8	6	GND	6	15	142.2				
7	3.8	7	0.0	7	134.0	16	146.3			
8	N/C	8	4.6	8	2	15.4	17	N/C		
9	3.9	9	17.9	9	3	GND	18	N/C		
10	3.6	10	0.0	10	10.5	14	151.8			
11	3.6	11	GND	11	0.1	1	6.9			
12	3.6	12	GND	12	4.8	2	2.5	2	6.9	
13	GND	13	4.8	13	2	2.5	2	6.9		
14	7.1	14	N/C	14	3	2.1	3	6.9		
15	GND	15	151.8	15	4	GND	4	GND		
16	3.2	16	142.2	16	5	2.3	5	6.9		
17	2.6	17	146.3	17	6	2.5	6	6.9		
18	9.1	18	N/C	18	7	0	7	6.9		
19	9.1	19	N/C	19	8	17.5	8	15		
IC5402		IC6501		IC8005						
PIN	VOLT	PIN	VOLT	PIN	VOLT					
1	95.6	1	98.2	1	2.5					
2	95.6	2	98.2	2	GND					
3	92.0	3	98.2	3	GND					
4	95.2	4	94.0	4	9.9					
5	99.1									

All voltages are in V.

D BOARD TRANSISTOR VOLTAGE LIST

Q5001	B	C	E	Q5525	B	C	E	Q8009	B	C	E
Q5004	3.8	12.0	3.8	Q5526	2.3	-17.0	2.7	Q8011	12.0	0.0	12.0
Q5005	0.2	3.8	GND	Q5527	2.9	3.5	2.3	Q8021	12.0	0.0	12.0
Q5008	0.0	2.1	GND	Q5528	-17.0	2.3	-17.0	Q8028	0.0	11.7	GND
Q5009	3.8	0.0	3.8	Q5701	7.4	12.0	7.2	Q8034	0.0	12.0	GND
Q5101	0.1	0.8	GND	Q5702	7.4	GND	7.2	Q8035	11.6	2.5	12.0
Q5102	0.0	0.1	GND	Q5703	3.4	GND	4.0				
Q5103	0.0	15.0	0.2	Q6402	5.5	0.0	GND				
Q5202	0.6	0.0	GND	Q6403	157.0	156.0	GND				
Q5203	0.9	9.0	GND	Q6404	0.0	0.0	GND				
Q5406	2.7	76.7	2.7	Q6802	15.4	0.0	15.4				
Q5520	0.0	13.0	GND	Q6803	133.0	3.7	132.0				
Q5521	14.6	0.0	14.6	Q8003	0.1	2.6	GND				
Q5522	5.8	204.0	5.2	Q8004	0.1	2.6	GND				
Q5523	4.0	17.0	3.4	Q8007	0.6	0.1	GND				
Q5524	2.8	-17.0	3.3	Q8008	0.6	0.1	GND				

All voltages are in V.

	D	G	S
Q5006	64.0	3.8	GND
Q5201	115.0	131.0	135.0
Q6400	306.0	145.0	140.0
Q6401	140.0	4.8	GND
Q8013	136.0	4.5	GND
Q8014	305.0	131.0	136.0

All voltages are in V.

D (1/3)

H/V DRIVE  
H/V DY

D BOARD SCHEMATIC DIAGRAM (2 OF 3)

D BOARD WAVEFORMS

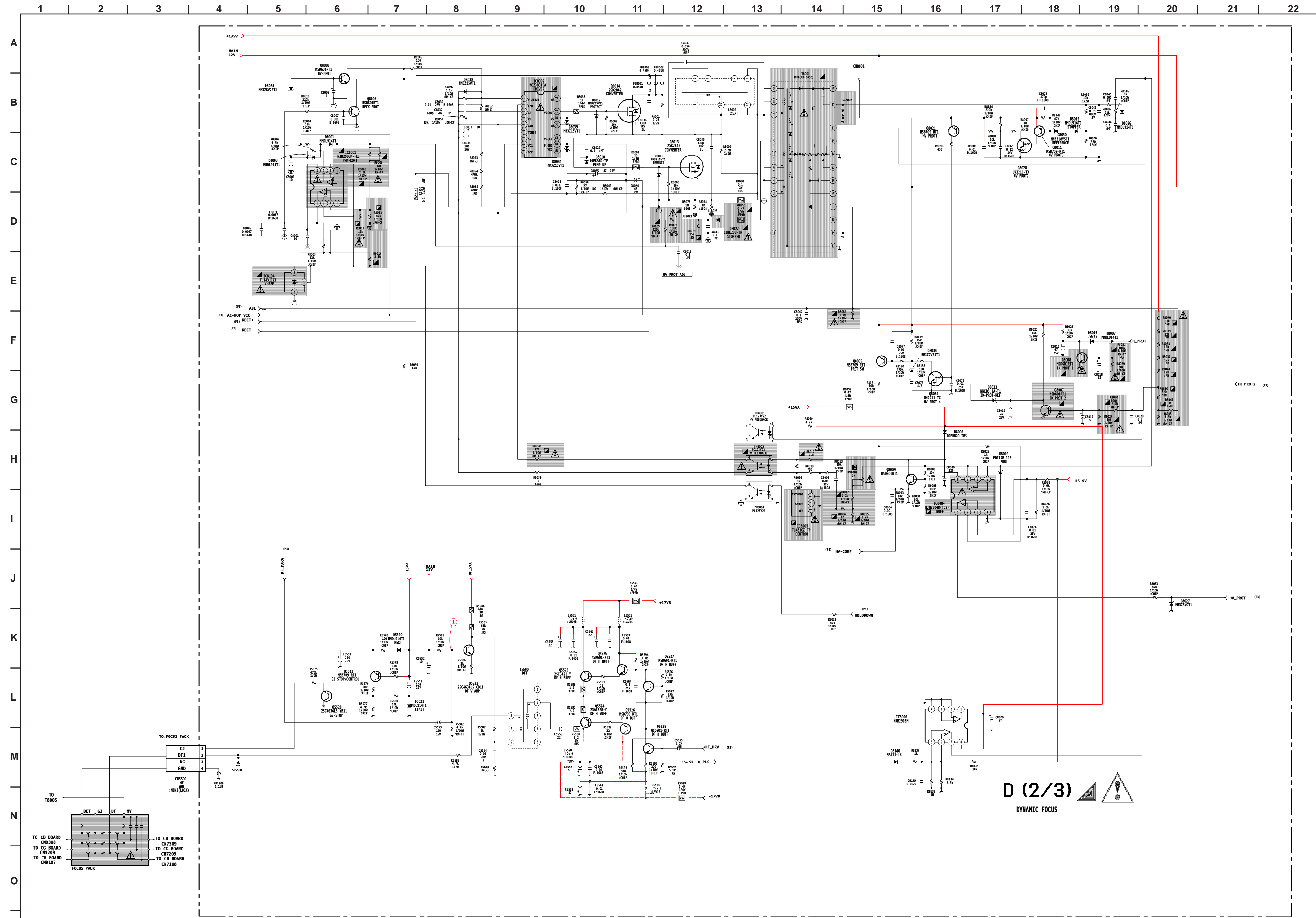
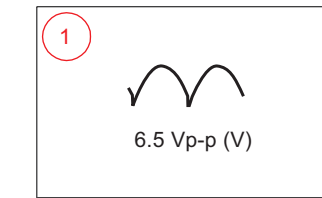

D (2/3)   
DYNAMIC FOCUS

D BOARD SCHEMATIC DIAGRAM (3 OF 3)

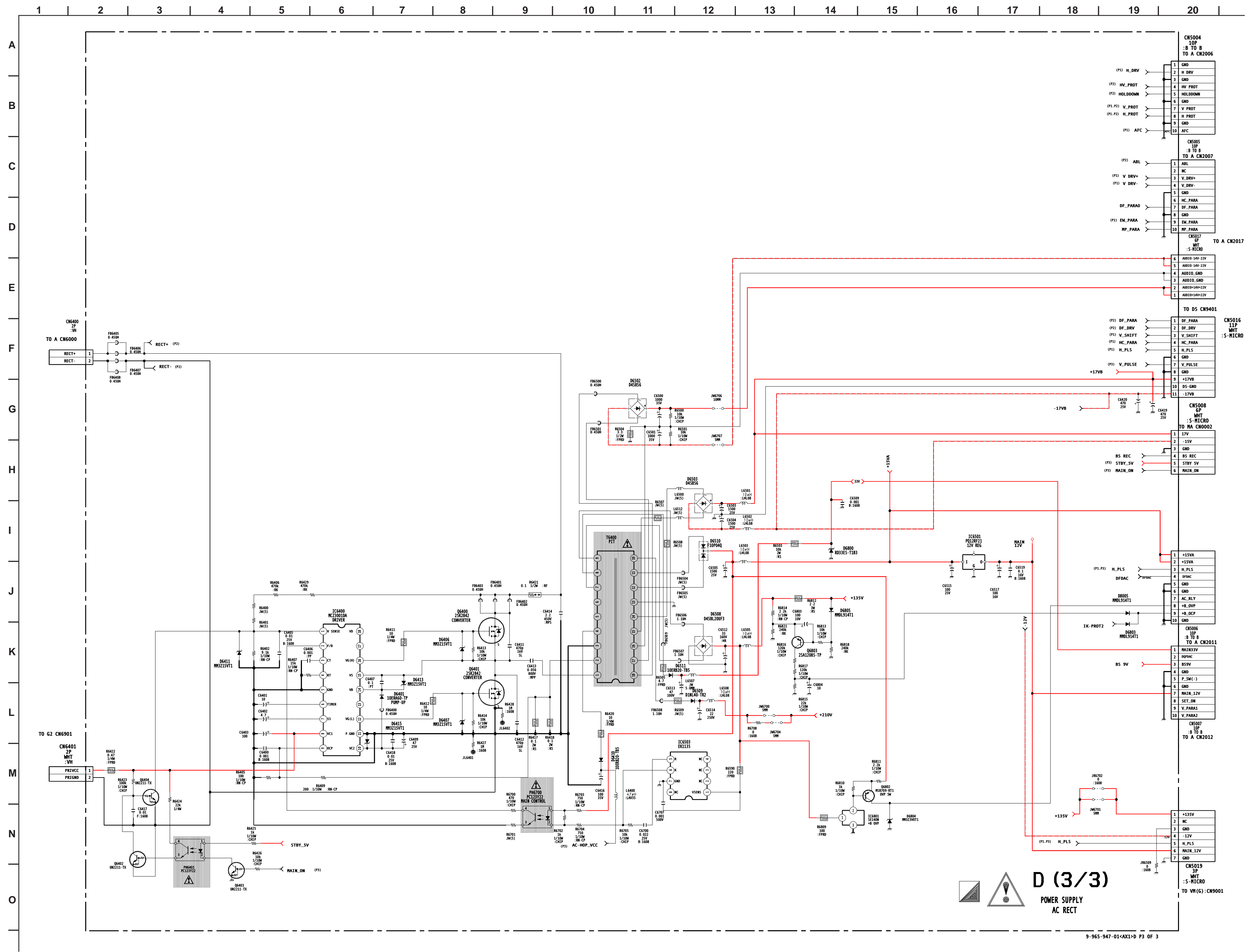

D

[H/V DRIVE, H/V DY, DYNAMIC FOCUS, POWER SUPPLY, AC RECT]

COMPONENT SIDE

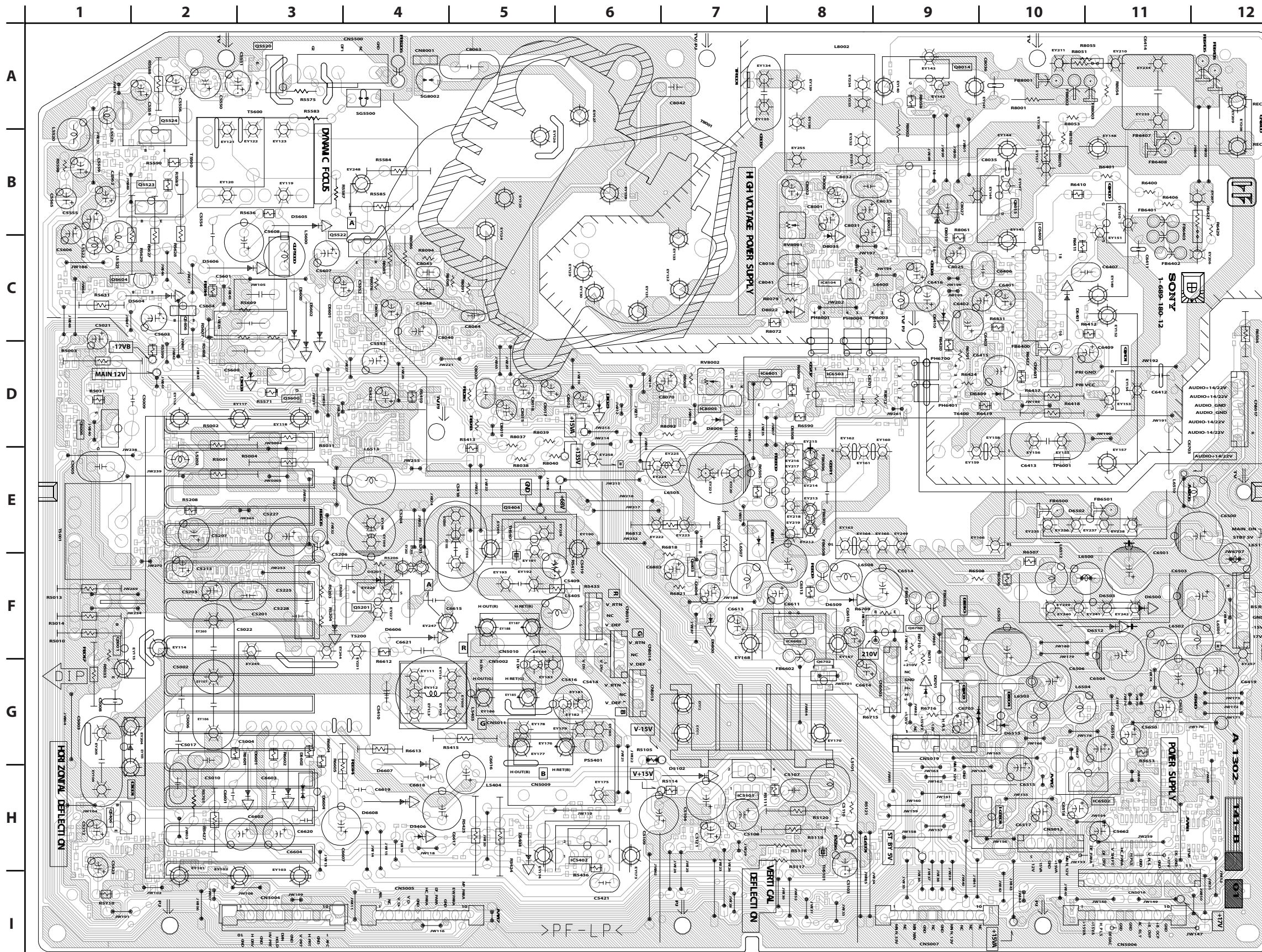

**D**

[HV DRIVE, HV DY, DYNAMIC FOCUS, POWER SUPPLY, AC RECT]

**CONDUCTOR SIDE**

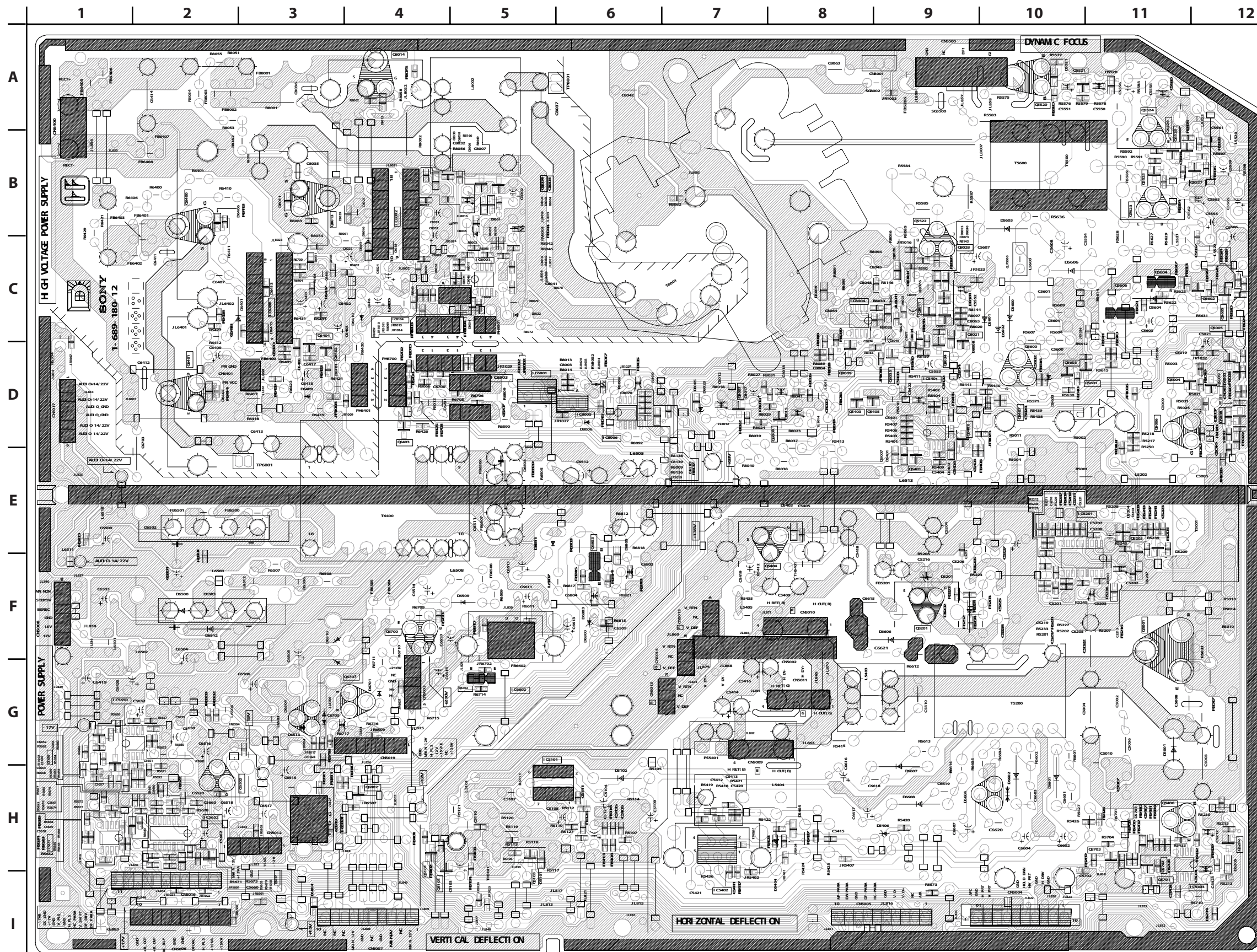

**D BOARD LOCATOR LIST**

DIODE		DIODE		TRANSISTOR	
D5003	D-12	D8010	B-4	Q5201	F-9
D5005	D-12	D8011	B-3	Q5202	H-12
D5101	H-5	D8012	A-4	Q5203	E-11
D5102	H-6	D8015	B-9	Q5406	H-11
D5201	F-9	D8022	C-5	Q5520	A-10
D5202	F-9	D8023	D-7	Q5521	A-10
D5203	E-11	D8024	B-5	Q5522	C-9
D5204	E-11	D8026	C-9	Q5523	B-11
D5205	H-12	D8027	C-9	Q5524	B-11
D5206	F-11	D8030	B-9	Q5525	B-11
D5207	F-11	D8034	D-9	Q5526	B-11
D5209	F-10	D8038	B-5	Q5527	B-12
D5404	I-7	D8039	B-4	Q5528	B-11
D5520	A-11	D8041	C-4	Q5701	I-11
D5521	A-10	D8140	E-7	Q5702	I-11
D5701	H-11	<b>IC</b>		Q5703	H-11
D6401	C-2	IC5101	F-5	Q6400	B-2
D6406	B-2	IC5201	E-10	Q6401	D-2
D6407	D-2	IC5402	H-7	Q6402	D-3
D6410	C-4	IC5403	I-11	Q6403	D-4
D6411	C-3	IC6400	C-3	Q6404	D-3
D6413	C-3	IC6501	H-3	Q6802	H-4
D6415	C-3	IC6503	D-4	Q6803	F-6
D6502	E-2	IC6602	F-5	Q8003	B-5
D6503	F-2	IC6801	D-5	Q8004	B-5
D6508	E-5	IC8001	C-5	Q8007	D-7
D6509	F-5	IC8002	B-4	Q8008	D-7
D6510	F-3	IC8004	C-8	Q8009	D-8
D6511	E-5	IC8005	D-5	Q8011	C-9
D6602	G-9	IC8006	D-5	Q8013	B-3
D6604	H-9	IC8104	C-4	Q8014	A-4
D6606	F-9	<b>TRANSISTOR</b>		Q8021	C-9
D6607	G-9	Q5001	F-11	Q8028	C-9
D6608	H-9	Q5004	D-11	Q8034	C-9
D6800	F-6	Q5005	C-12	Q8035	D-9
D6803	F-6	Q5006	D-11		
D6804	I-3	Q5008	D-11		
D6805	E-6	Q5009	D-11		
D8001	B-5	Q5101	I-4		
D8003	B-5	Q5102	I-4		
D8005	D-7	Q5103	H-5		
D8006	D-6				
D8007	E-9				
D8008	C-9				
D8009	C-8				

UD BOARD SCHEMATIC DIAGRAM

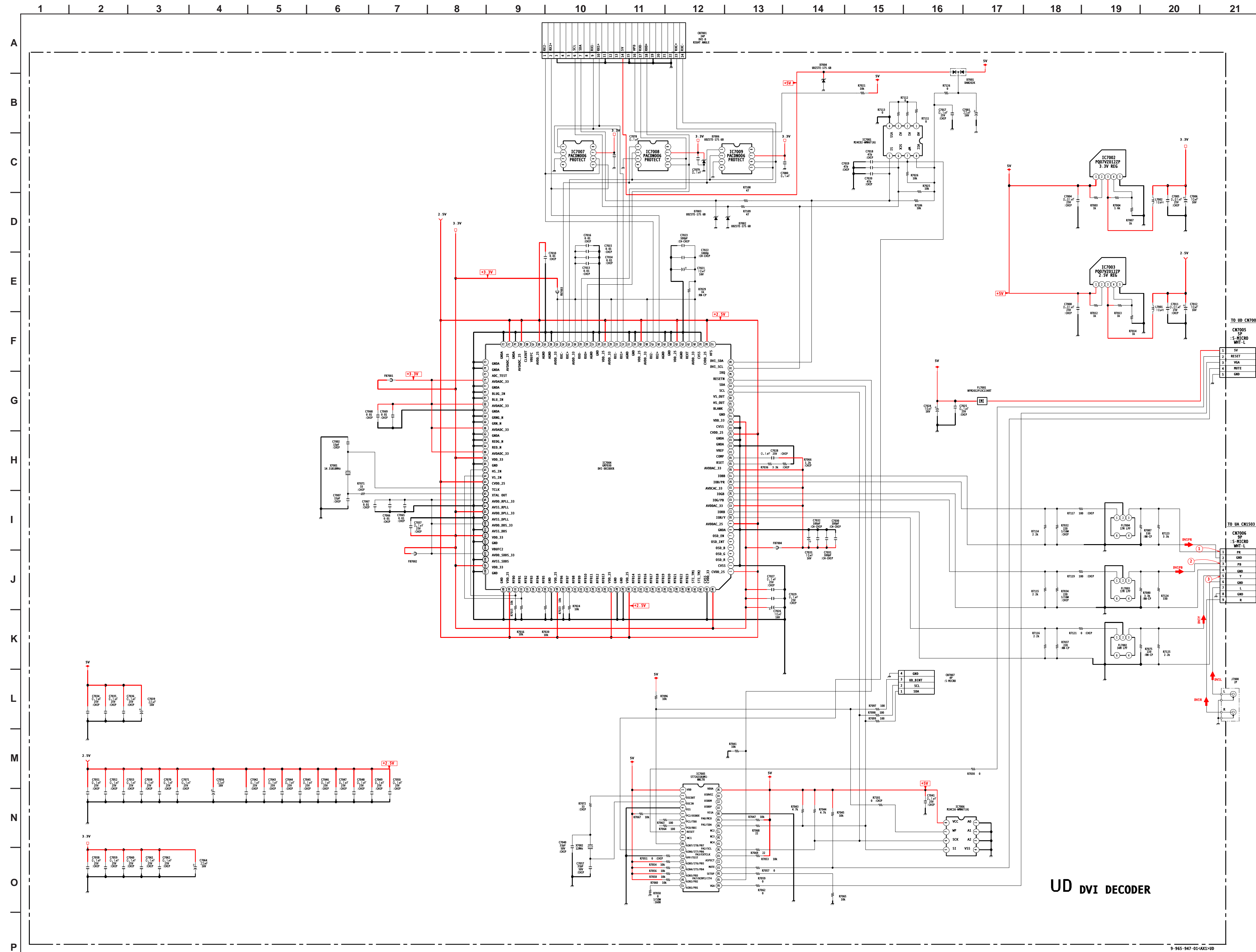

UD BOARD WAVEFORMS

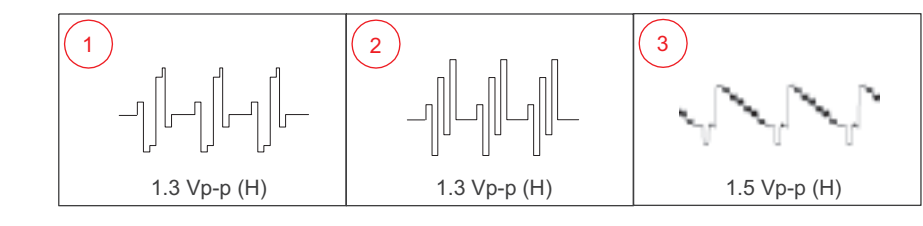

UD DVI DECODER

**UD** [DVI DECODER]  
**COMPONENT SIDE**

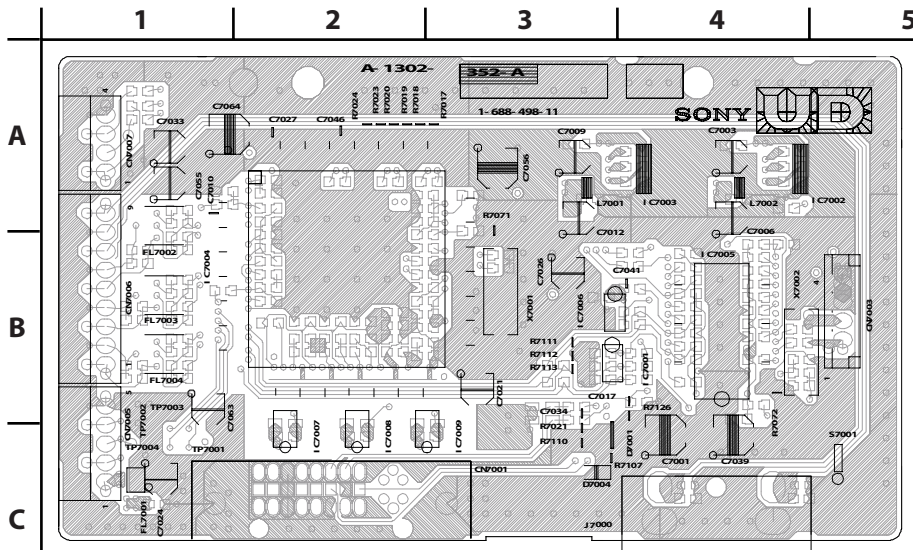

**UD** [DVI DECODER]  
**CONDUCTOR SIDE**

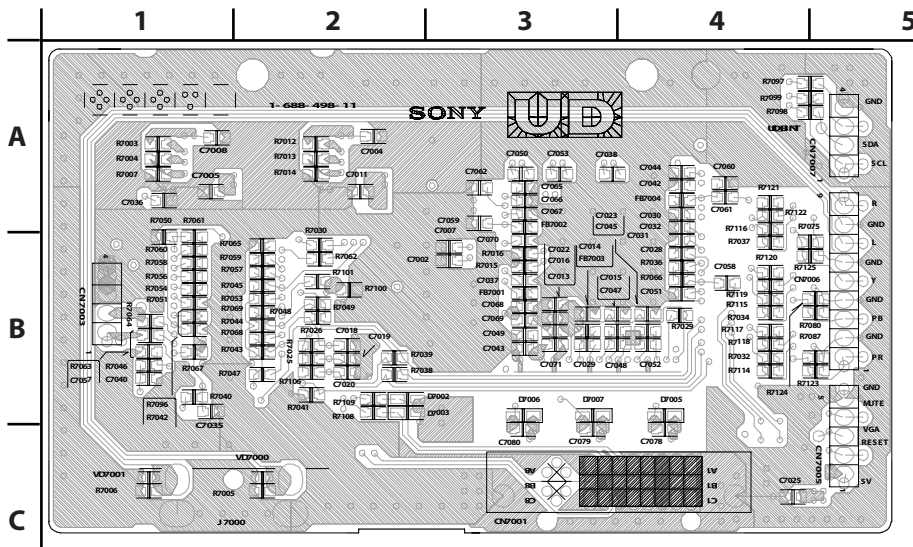



BM BOARD SCHEMATIC DIAGRAM (1 OF 3)

Due to the complexity of this board, performing component level field repairs is not recommended. If service is required, complete board replacement is the preferred repair method. Data is provided for reference only.

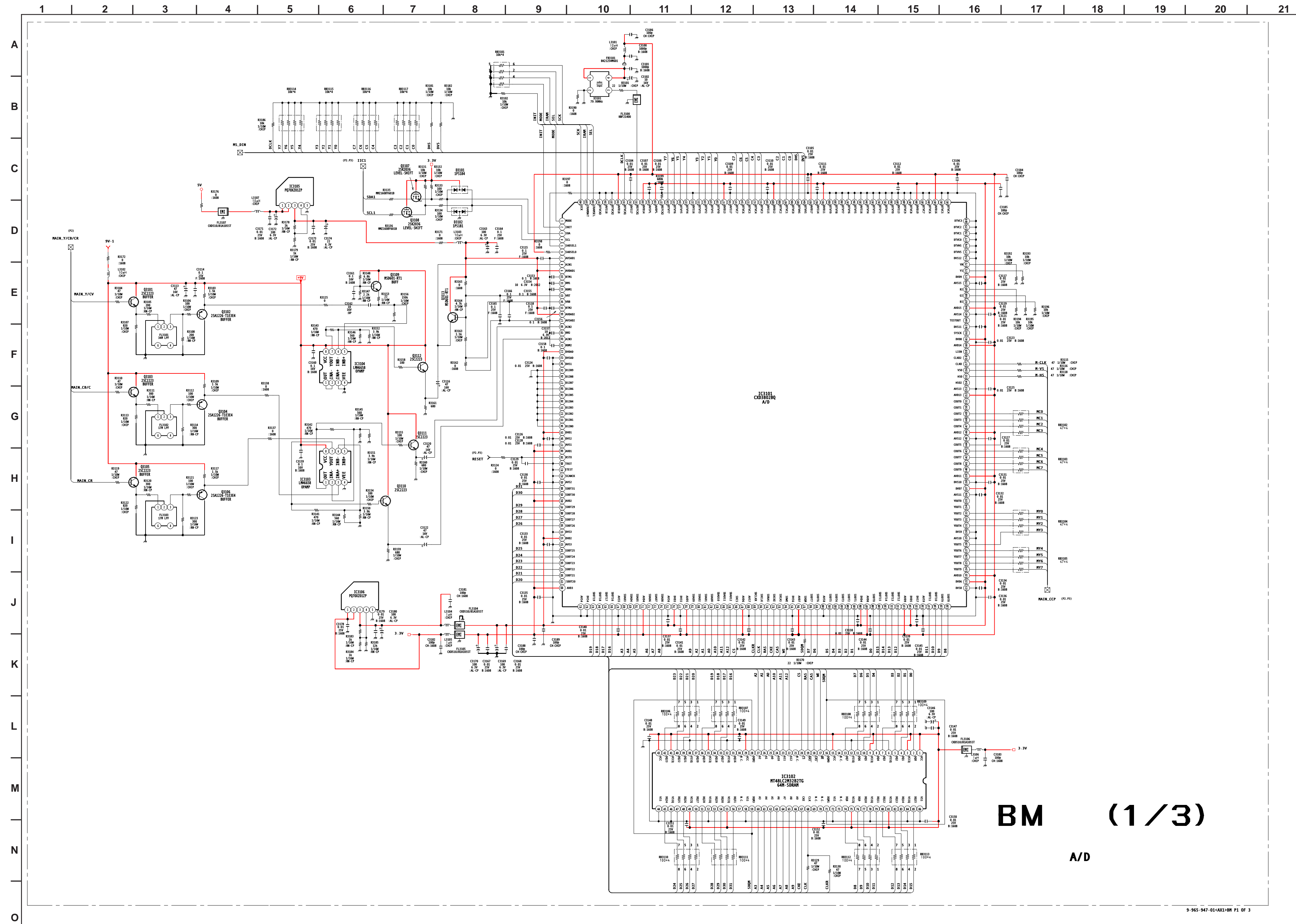

BM (1/3)  
A/D

BM BOARD SCHEMATIC DIAGRAM (2 OF 3)

Due to the complexity of this board, performing component level field repairs is not recommended. If service is required, complete board replacement is the preferred repair method. Data is provided for reference only.

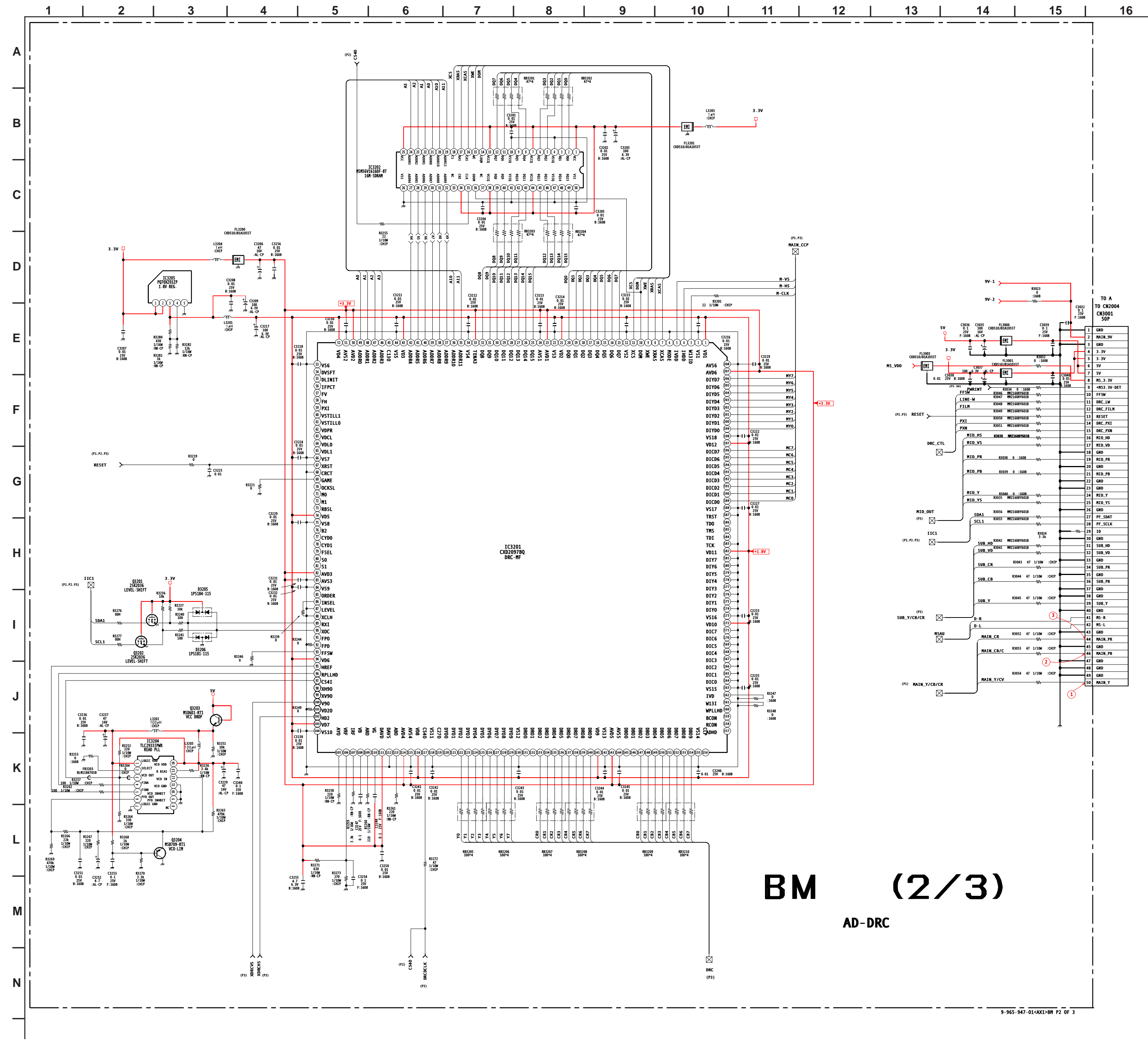

**BM (2/3)**  
AD-DRC

BM BOARD WAVEFORMS

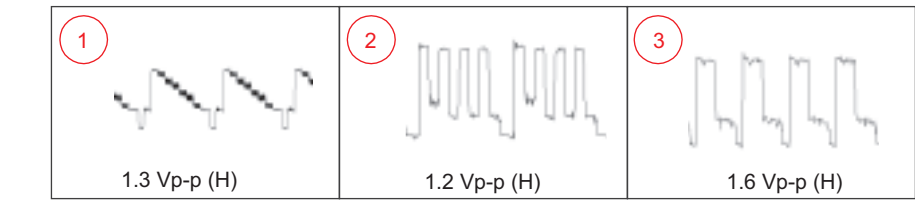

9-965-947-01(A&L)-RM P2 OF 3



**BM** [A/D, AD-DRC, MID-XA]  
**COMPONENT SIDE**

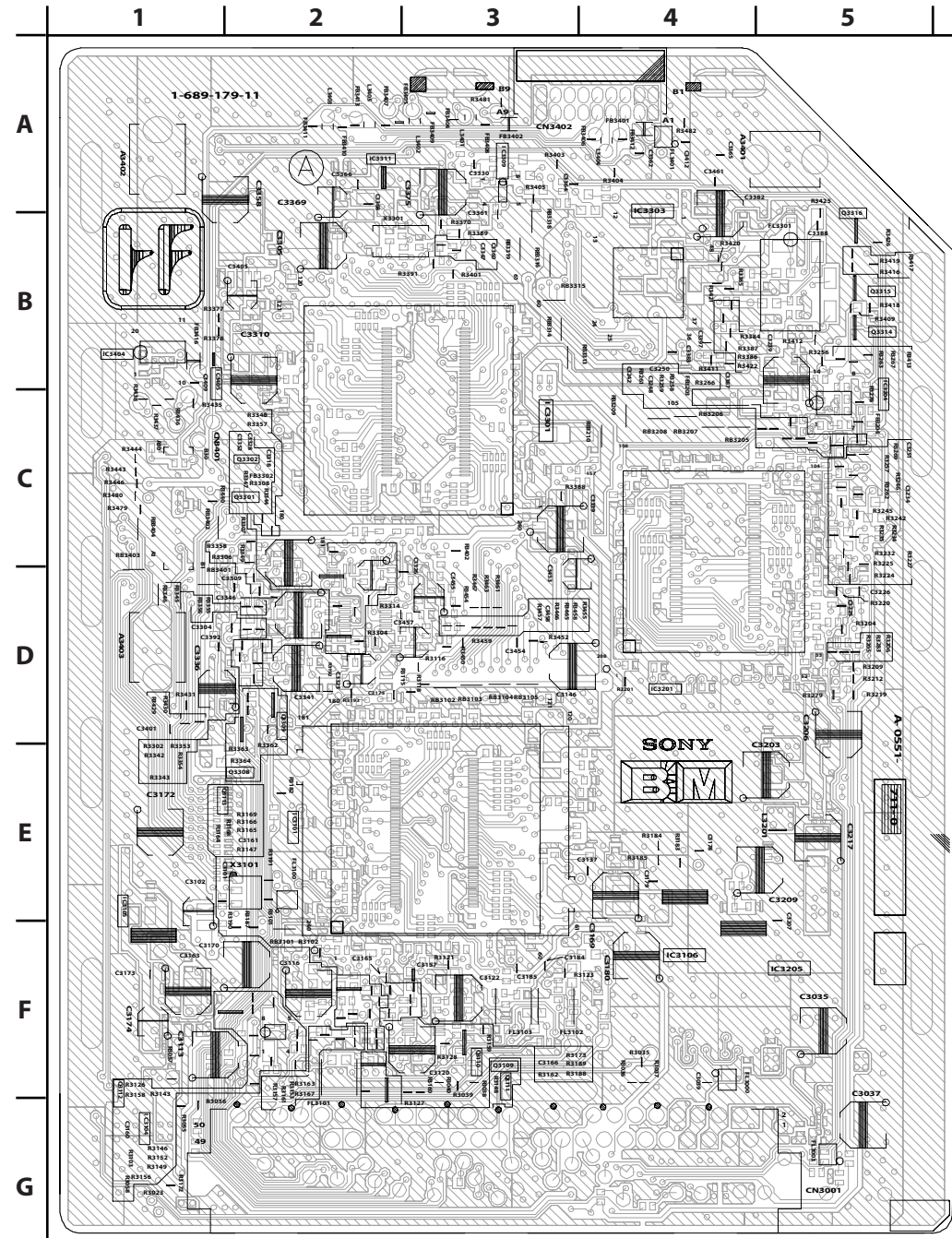

**BM** [A/D, AD-DRC, MID-XA]  
**CONDUCTOR SIDE**

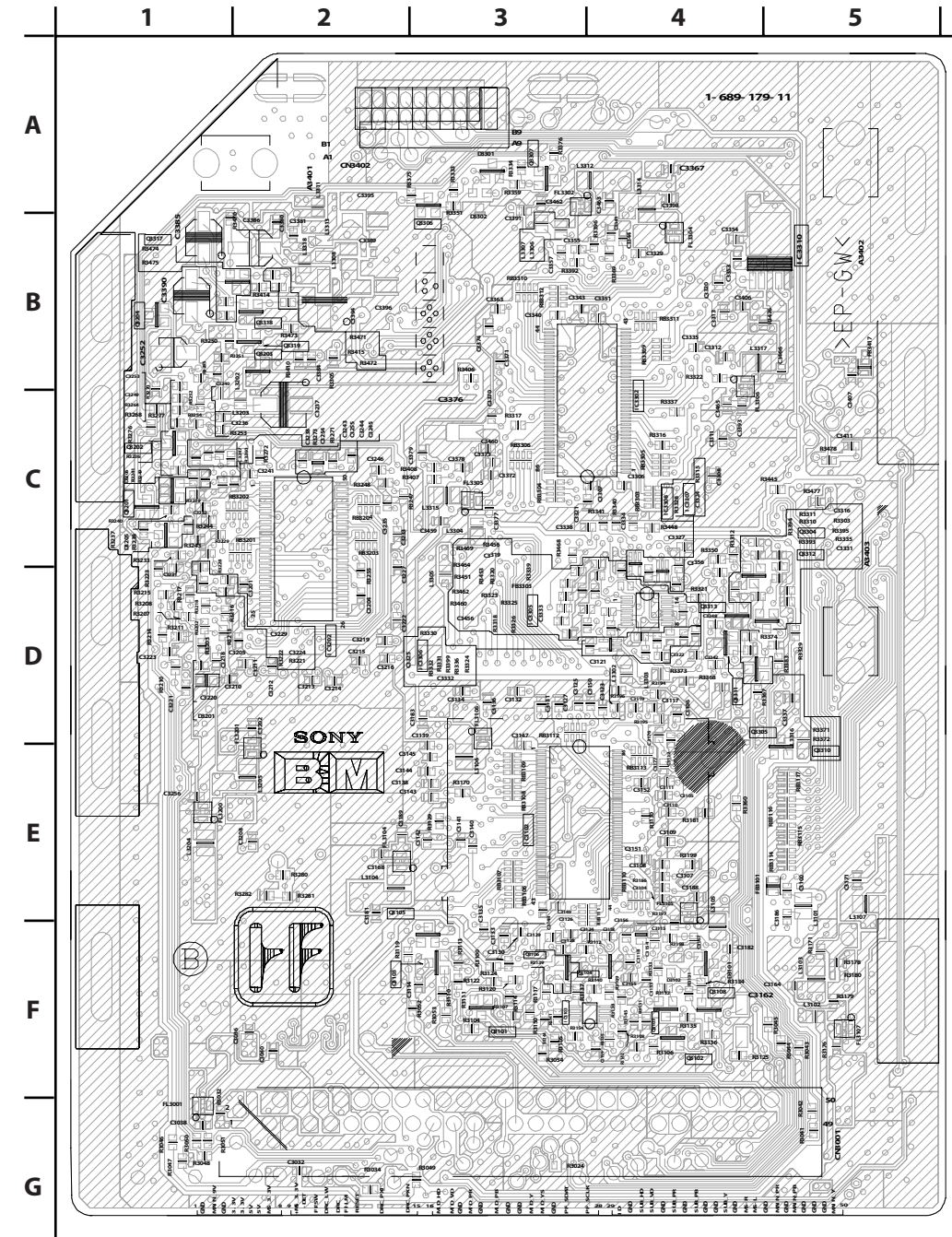

DS BOARD SCHEMATIC DIAGRAM

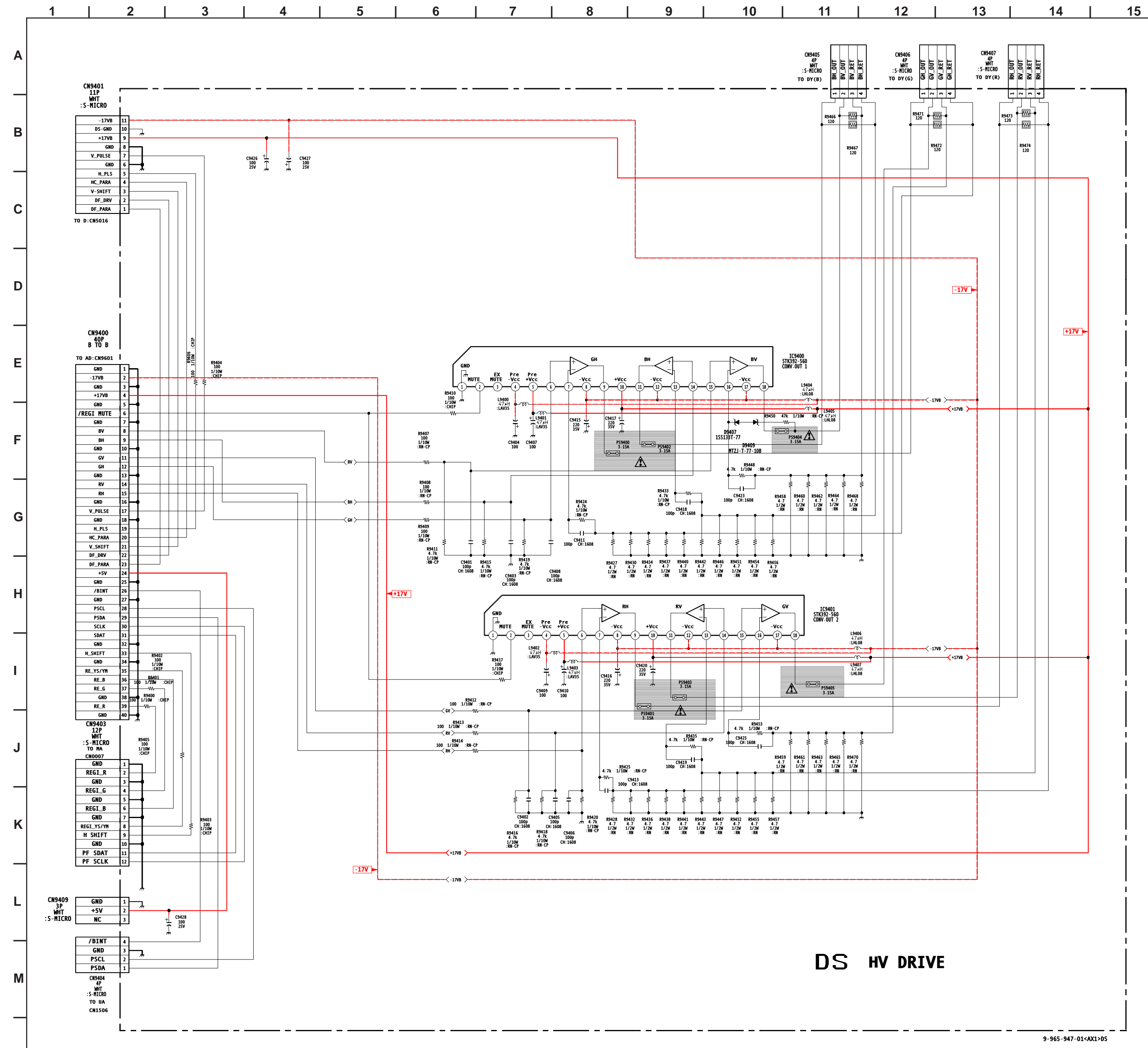

DS BOARD IC VOLTAGE LIST

IC9400		IC9401	
PIN	VOLT	PIN	VOLT
1	GND	1	GND
2	4.3	2	4.3
3	N/C	3	N/C
4	-17.0	4	-17.0
5	17.0	5	17.0
6	-0.3	6	-0.1
7	-0.3	7	-0.1
8	-17.0	8	-17.0
9	-0.5	9	0.0
10	17.0	10	17.0
11	0.1	11	0.5
12	-17.0	12	-17.0
13	0.0	13	0.3
14	0.0	14	0.3
15	0.0	15	0
16	0.0	16	0
17	-17.0	17	-17.0
18	0.1	18	0.1

All voltages are in V.

**DS** [HV DRIVE]  
COMPONENT SIDE

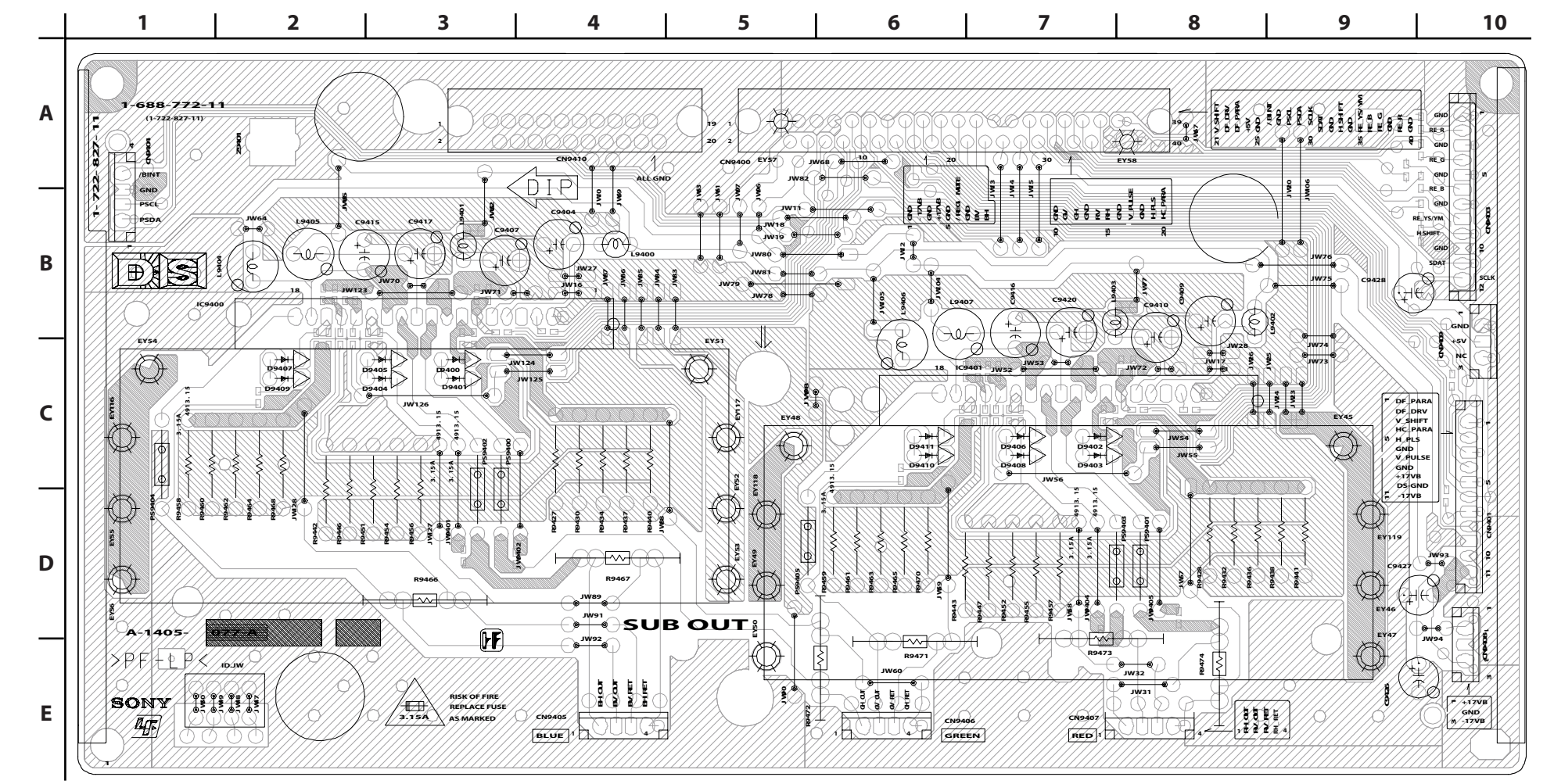

**DS** [HV DRIVE]  
CONDUCTOR SIDE

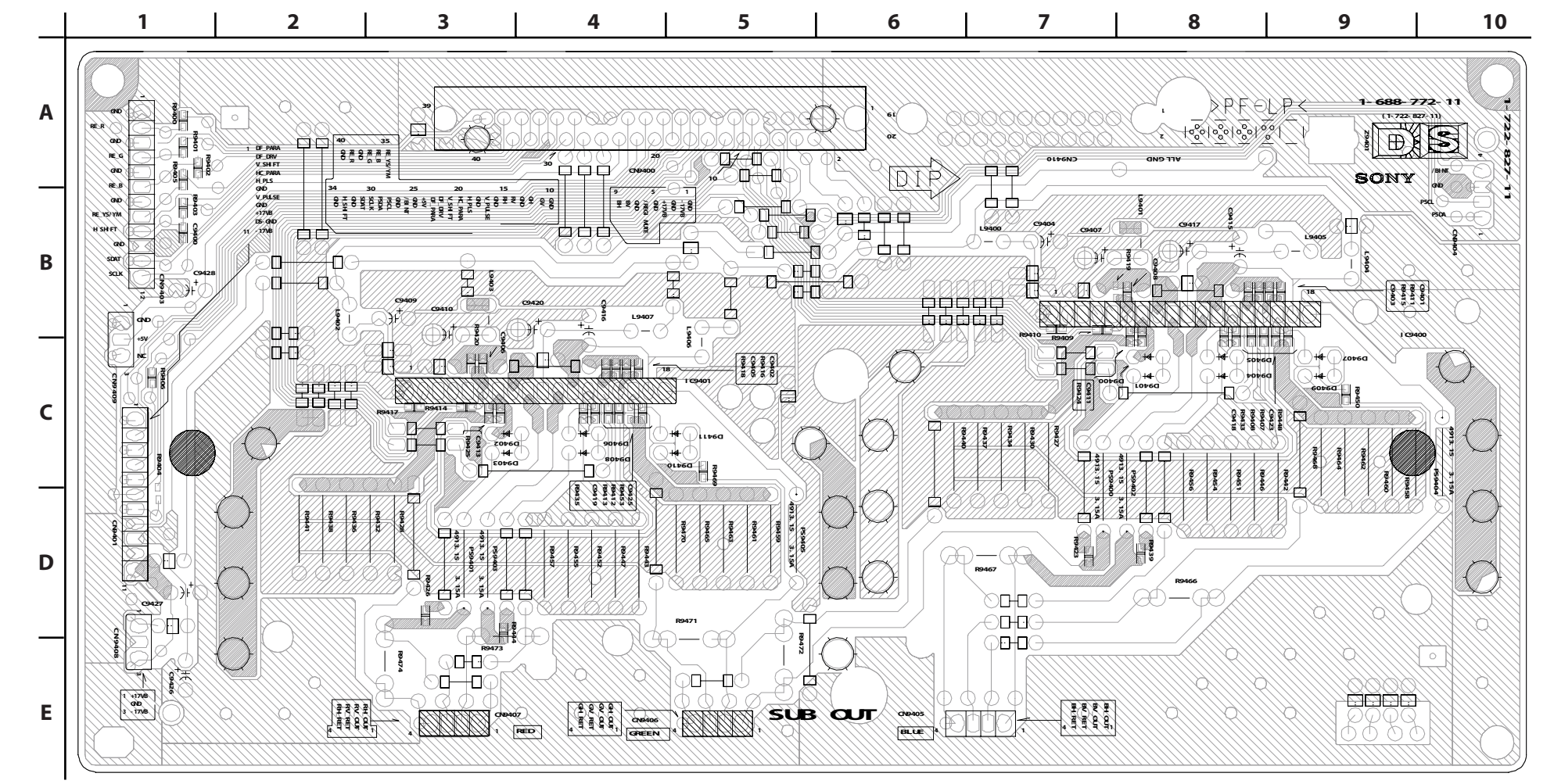

G2 BOARD SCHEMATIC DIAGRAM

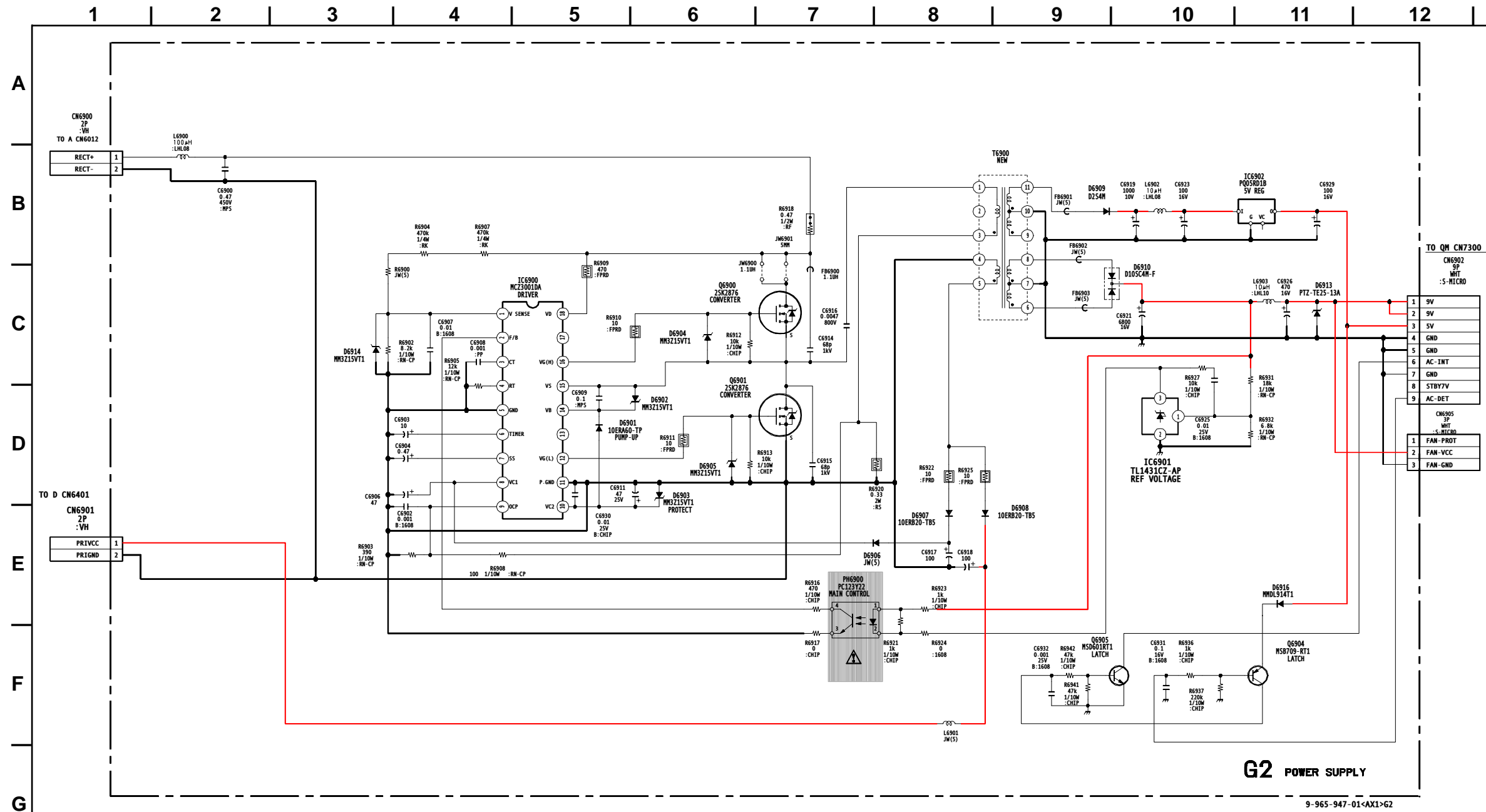

G2 BOARD IC VOLTAGE LIST

IC6901		IC6900	
PIN	VOLT	PIN	VOLT
1	2.4	1	2.8
2	GND	2	1.9
3	6.1	3	2.2
IC6902		4	1.5
PIN	VOLT	PIN	VOLT
I	6.7	6	0.0
O	5.0	7	4.6
G	GND	8	20.1
		9	0.0
		10	10.5
		11	GND
		12	4.9
		13	N/C
		14	155.6
		15	145.6
		16	150.6
		17	N/C
		18	304.5

All voltages are in V.

G2 BOARD TRANSISTOR VOLTAGE LIST

	B	C	E
Q6904	7.5	4.9	0.0
Q6905	0.0	0.0	3.0

	D	G	S
Q6900	156.0	4.9	0.0
Q6901	302.5	160.0	156.0

All voltages are in V.

G2 POWER SUPPLY

9-965-947-01<AX1>G2

**G2** [POWER SUPPLY]  
COMPONENT SIDE

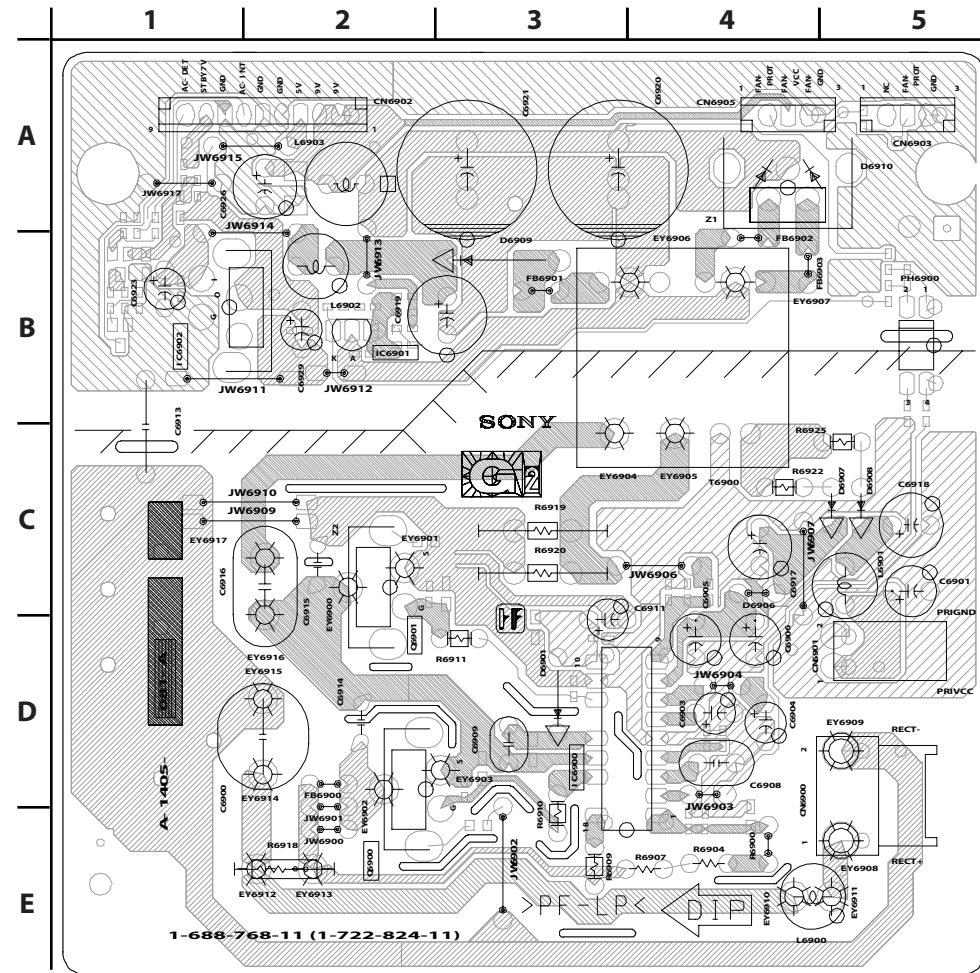

**G2** [POWER SUPPLY]  
CONDUCTOR SIDE

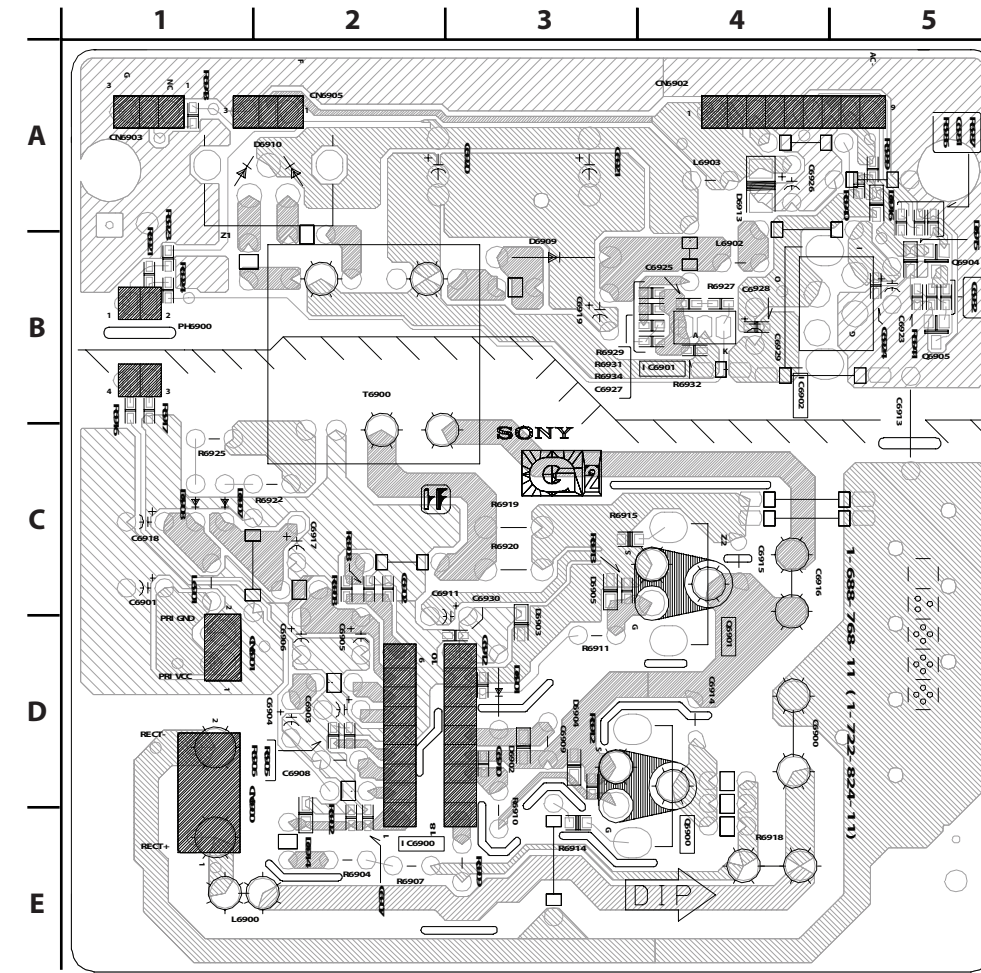

**G2 BOARD LOCATOR LIST**

DIODE		IC	
D6901	D-3	IC6900	D-2
D6902	D-3	IC6901	B-4
D6903	D-3	IC6902	B-4
D6904	D-3	<b>TRANSISTOR</b>	
D6905	C-3	Q6900	D-3
D6907	C-1	Q6901	C-4
D6908	C-1	Q6904	B-5
D6909	B-3	Q6905	B-5
D6910	A-1		
D6913	A-4		
D6914	E-2		
D6916	A-5		

QI BOARD SCHEMATIC DIAGRAM (1 OF 3)

Due to the complexity of this board, performing component level repairs is not recommended. If it is determined that this board has malfunctioned, the Complete Q Box (A-1606-037-A) must be replaced.

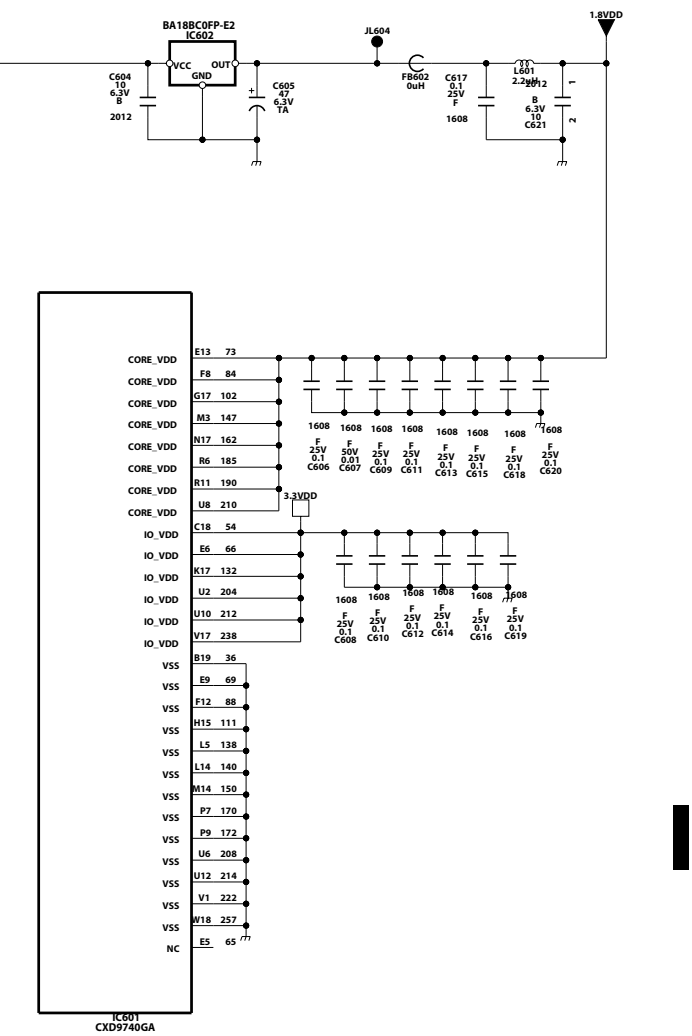
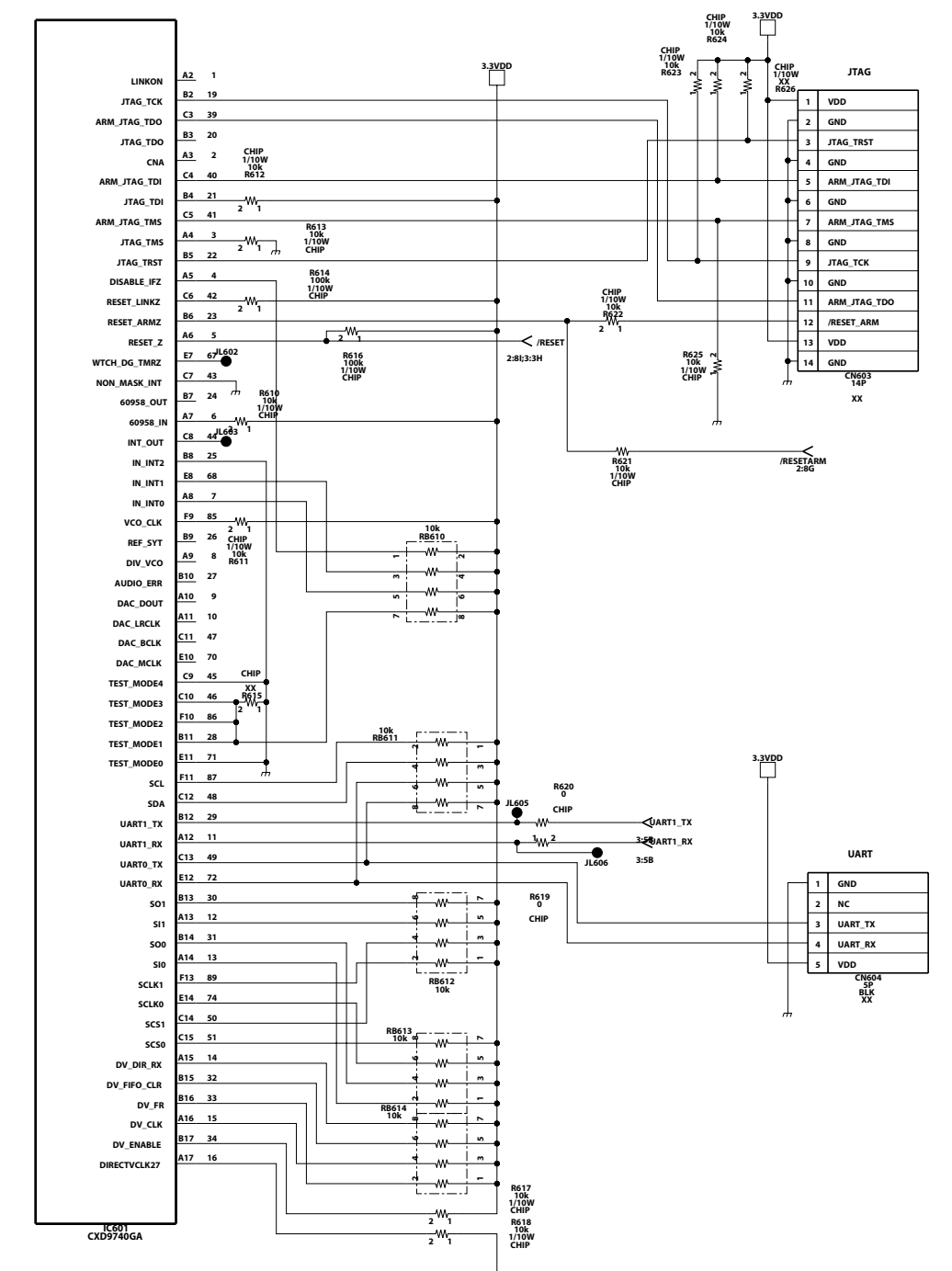
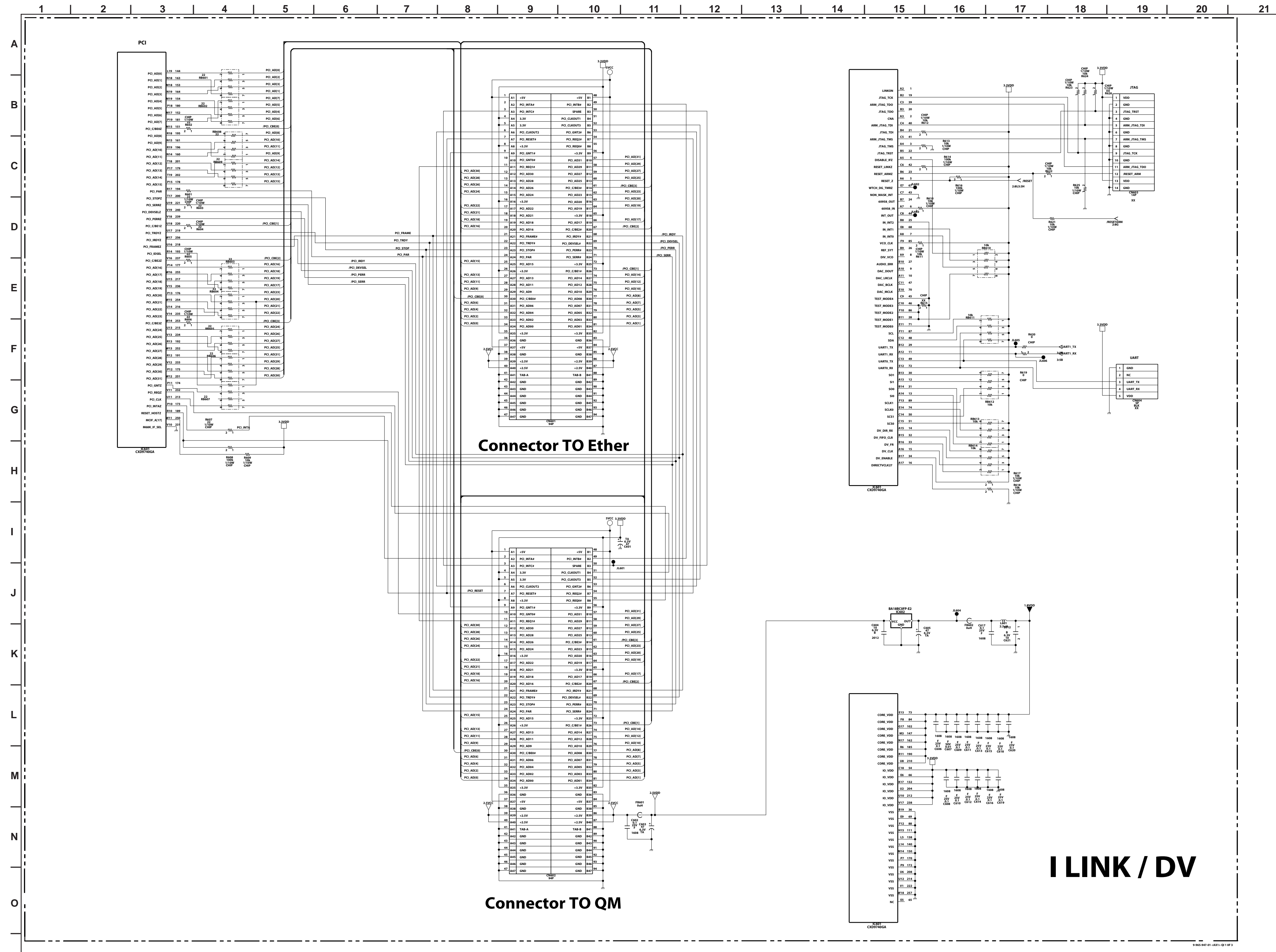

I LINK / DV





QI BOARD SCHEMATIC DIAGRAM (3 OF 3)

Due to the complexity of this board, performing component level field repairs is not recommended. If it is determined that this board has malfunctioned, the Complete Q Box (A-1606-037-A) must be replaced.

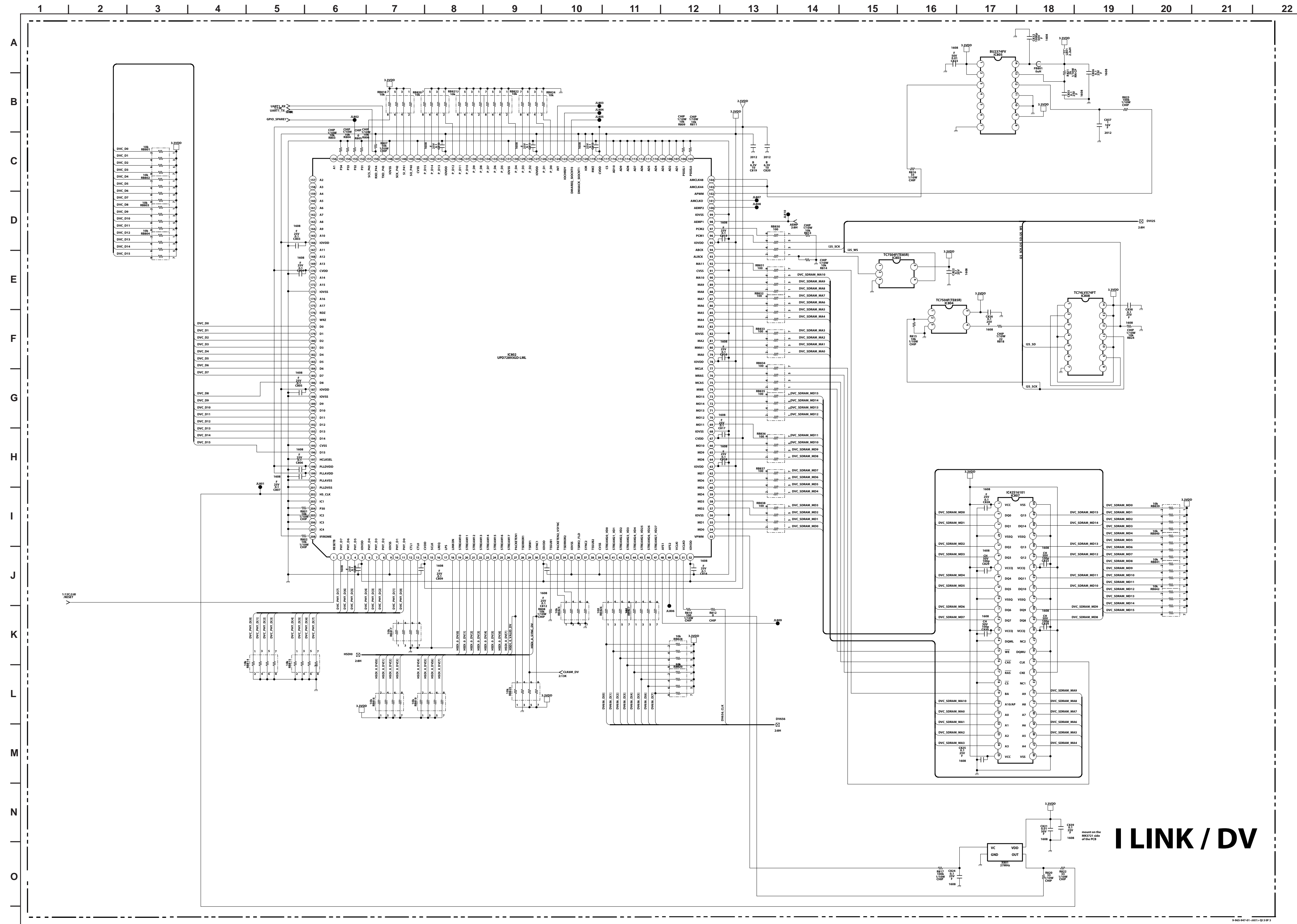



[I LINK, DV]

**COMPONENT SIDE**

Due to the complexity of this board, performing component level field repairs is not recommended. If it is determined that this board has malfunctioned, the Complete Q Box (A-1606-037-A) must be replaced.

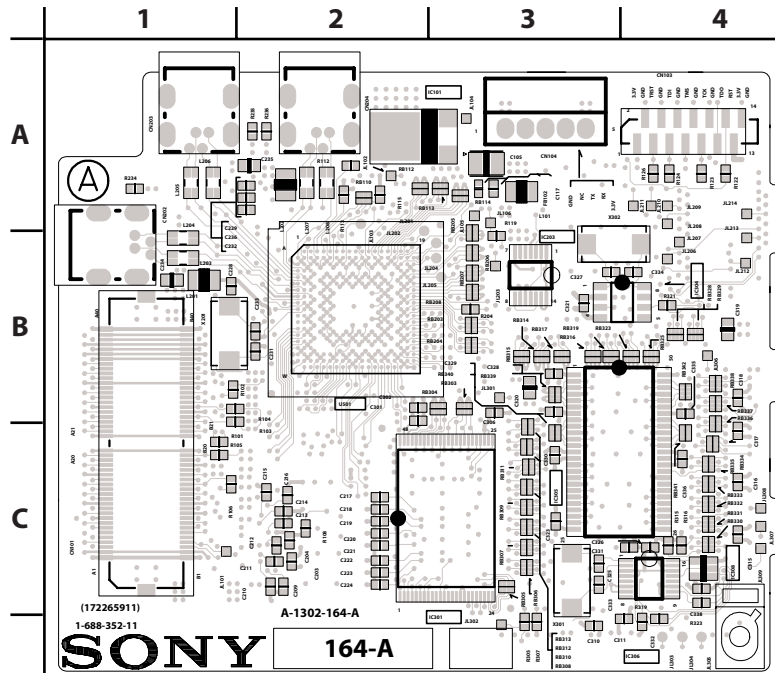

[I LINK, DV]

**CONDUCTOR SIDE**

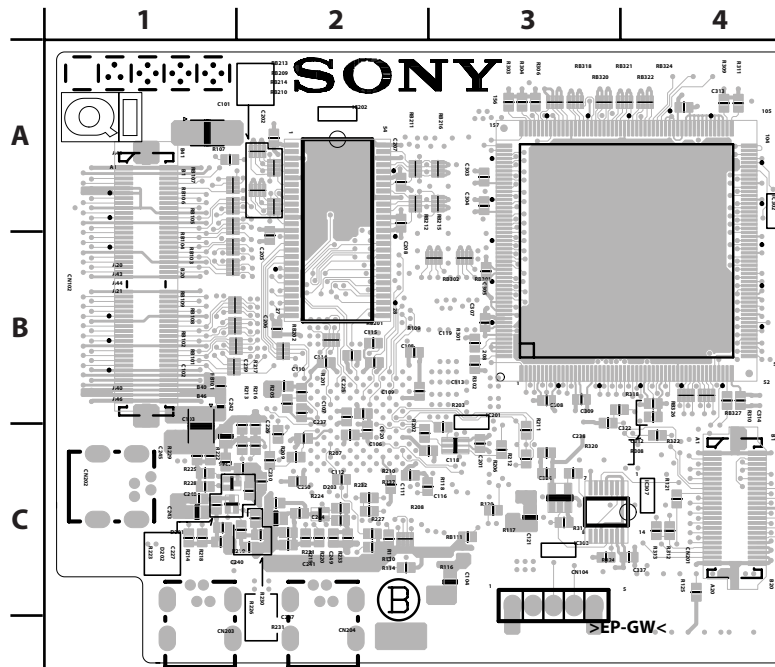



QM BOARD SCHEMATIC DIAGRAM (2 OF 5) Due to the complexity of this board, performing component level field repairs is not recommended. If it is determined that this board has malfunctioned, the Complete Q Box (A-1606-037-A) must be replaced.

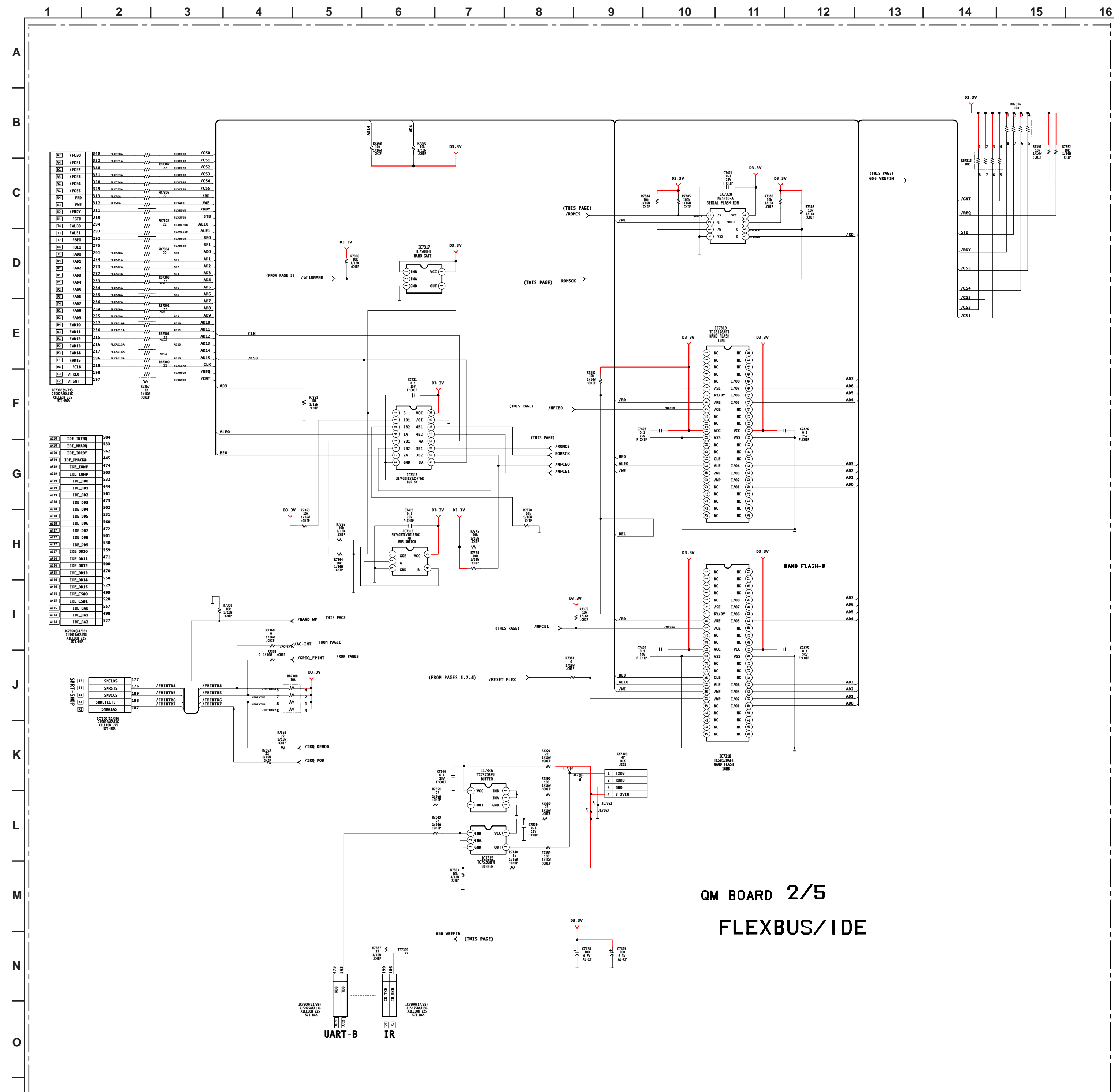



QM BOARD SCHEMATIC DIAGRAM (4 OF 5) Due to the complexity of this board, performing component level repairs is not recommended. If it is determined that this board has malfunctioned, the Complete Q Box (A-1606-037-A) must be replaced.

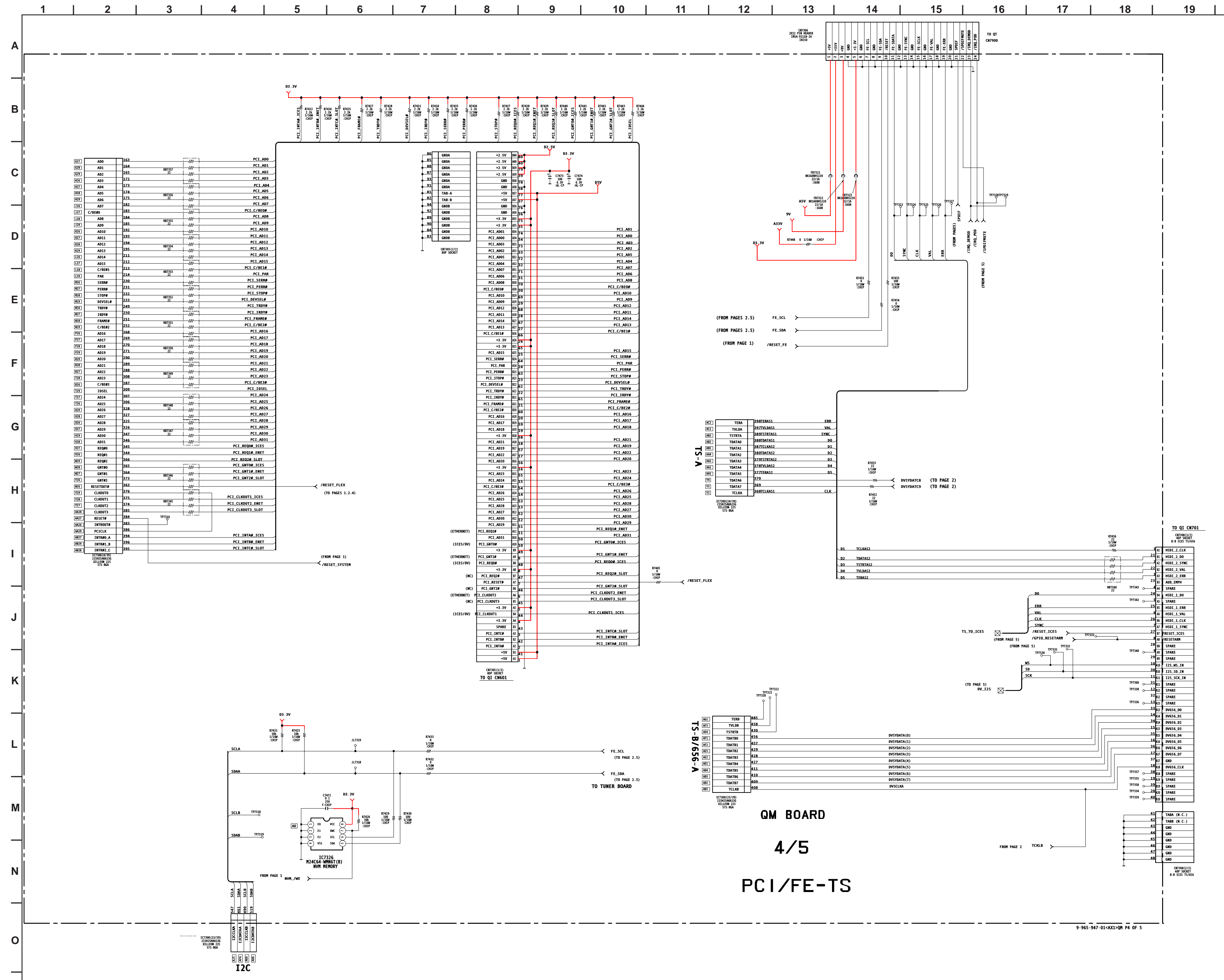

QM BOARD SCHEMATIC DIAGRAM (5 OF 5) Due to the complexity of this board, performing component level repairs is not recommended. If it is determined that this board has malfunctioned, the Complete Q Box (A-1606-037-A) must be replaced.

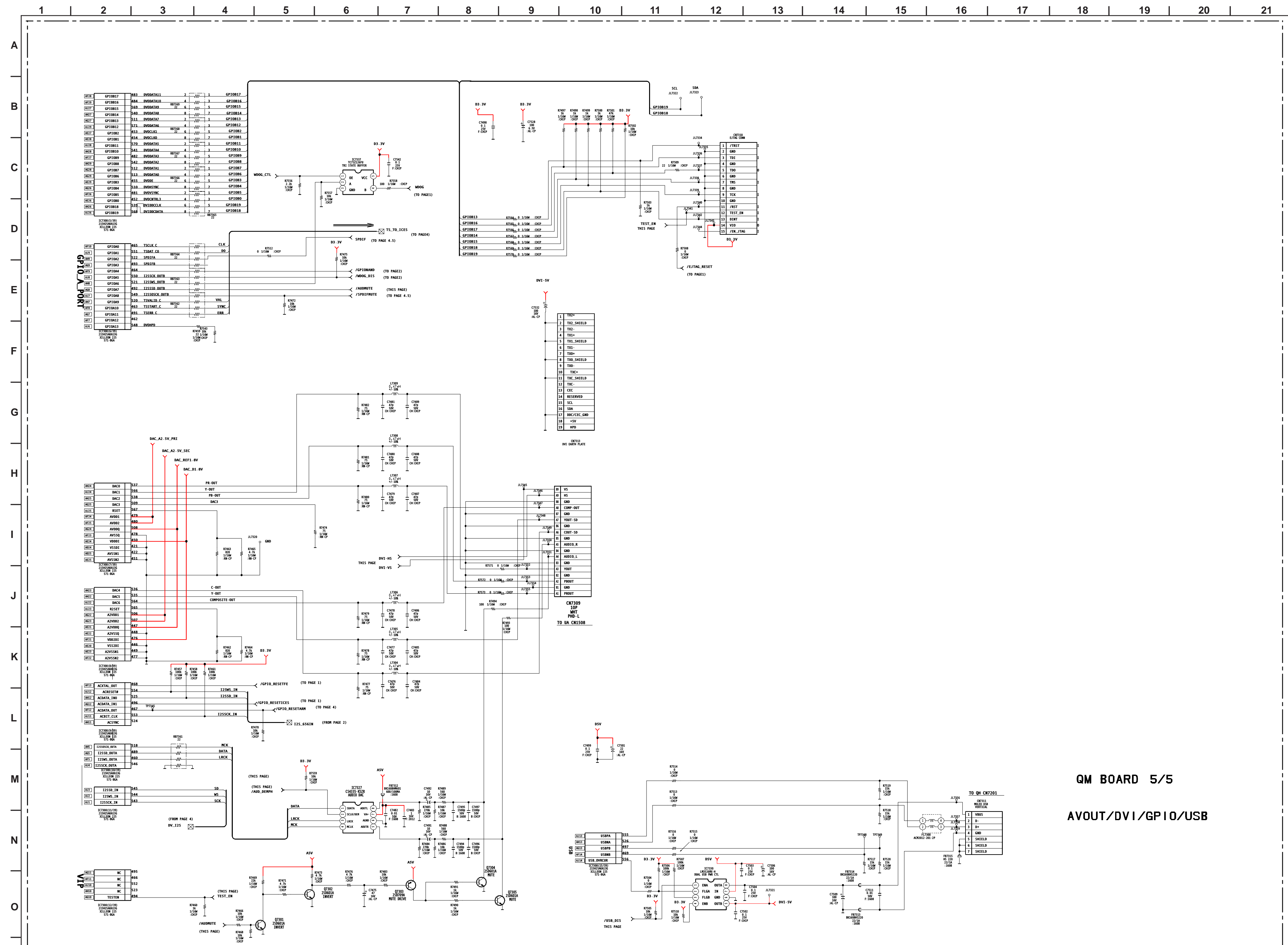

QM BOARD 5/5  
AVOUT/DVI/GPIO/USB





[POWER, RESET, UART, FLEXBUS, IDE, DDR, PCI, FE-TS, AVOUT, DVI, GPIO, USB]

COMPONENT SIDE

Due to the complexity of this board, performing component level field repairs is not recommended. If it is determined that this board has malfunctioned, the Complete Q Box (A-1606-037-A) must be replaced.

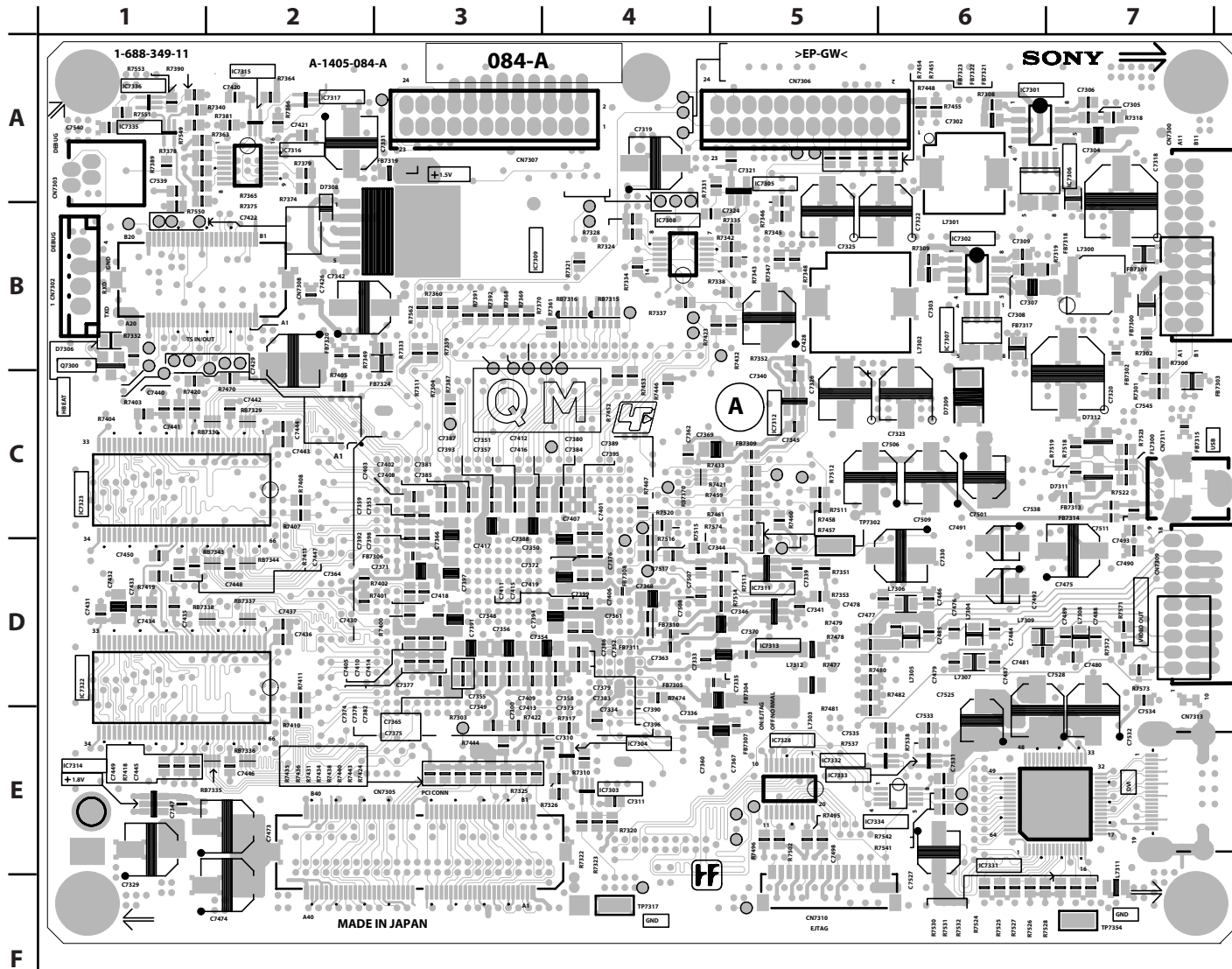



[POWER, RESET, UART, FLEXBUS, IDE, DDR, PCI, FE-TS, AVOUT, DVI, GPIO, USB]

Due to the complexity of this board, performing component level field repairs is not recommended. If it is determined that this board has malfunctioned, the Complete Q Box (A-1606-037-A) must be replaced.

CONDUCTOR SIDE

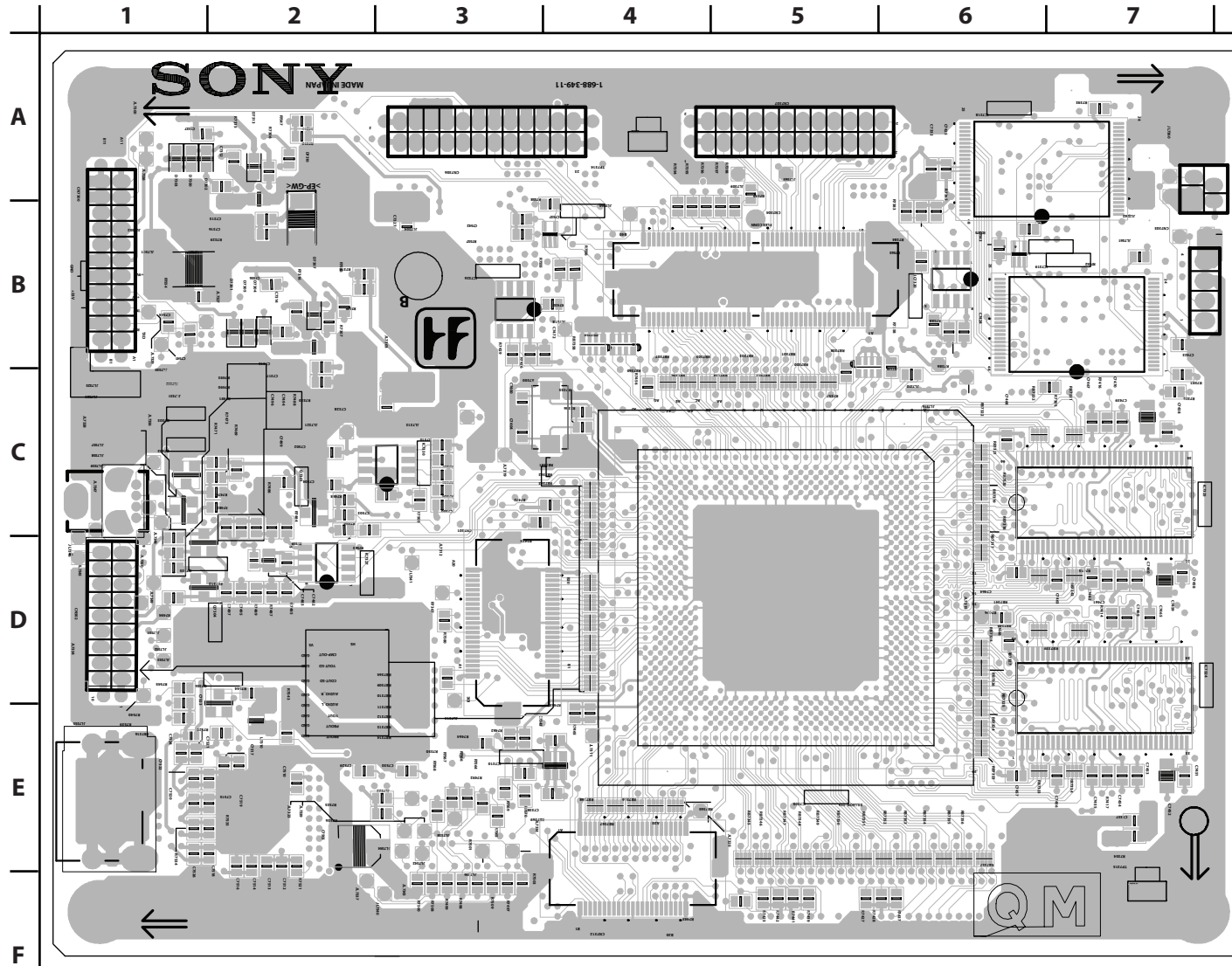

QT BOARD SCHEMATIC DIAGRAM

Due to the complexity of this board, performing component level field repairs is not recommended. If it is determined that this board has malfunctioned, the Complete Q Box (A-1606-037-A) must be replaced.

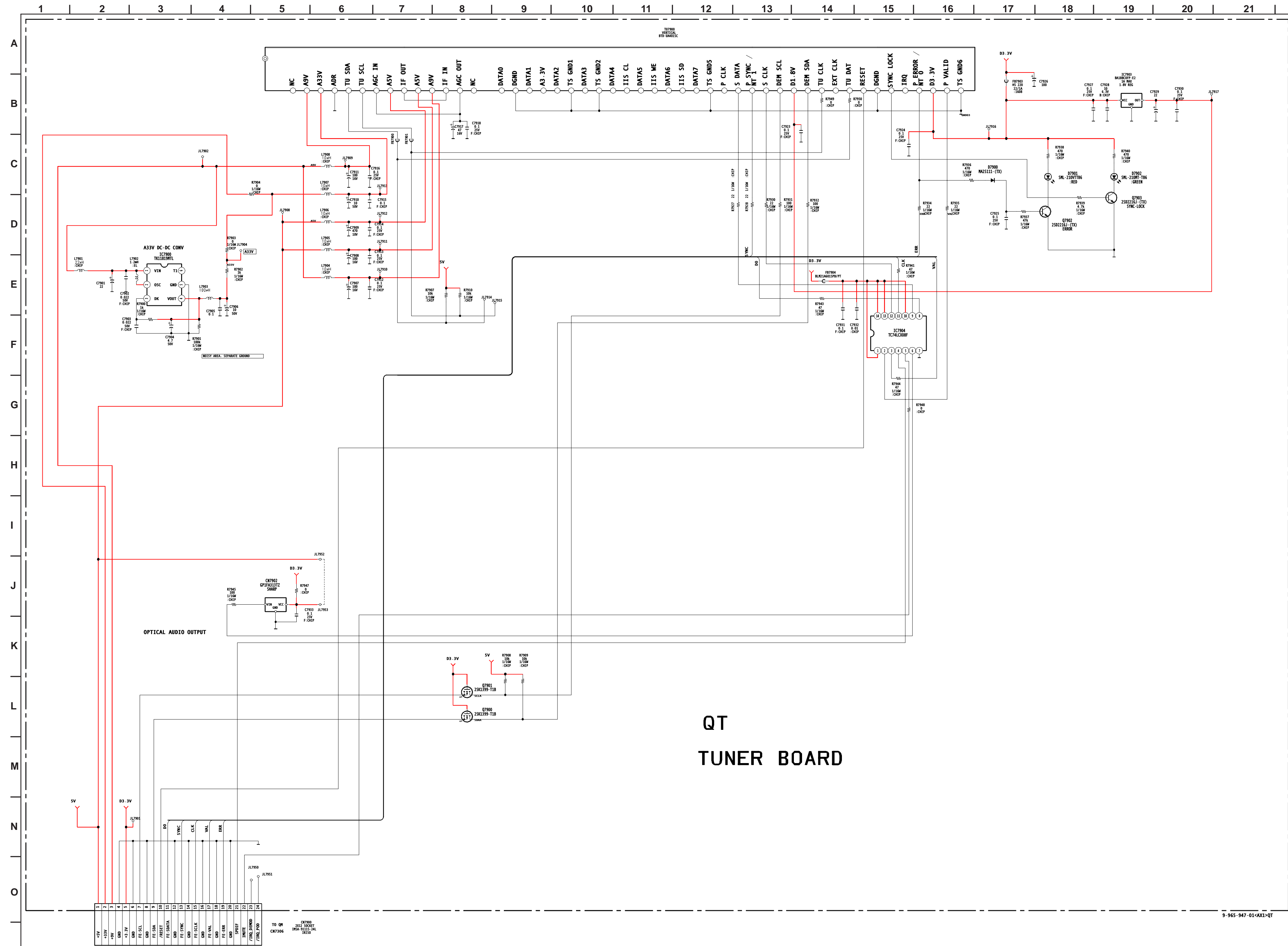

QT TUNER BOARD

**QT**

[TUNER BOARD]

**COMPONENT SIDE**

Due to the complexity of this board, performing component level field repairs is not recommended. If it is determined that this board has malfunctioned, the Complete Q Box (A-1606-037-A) must be replaced.

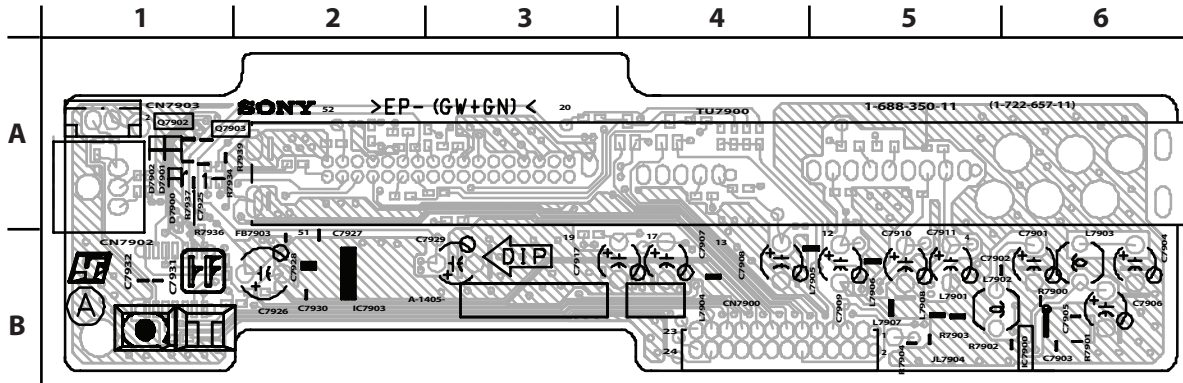

**QT**

[TUNER BOARD]

**CONDUCTOR SIDE**

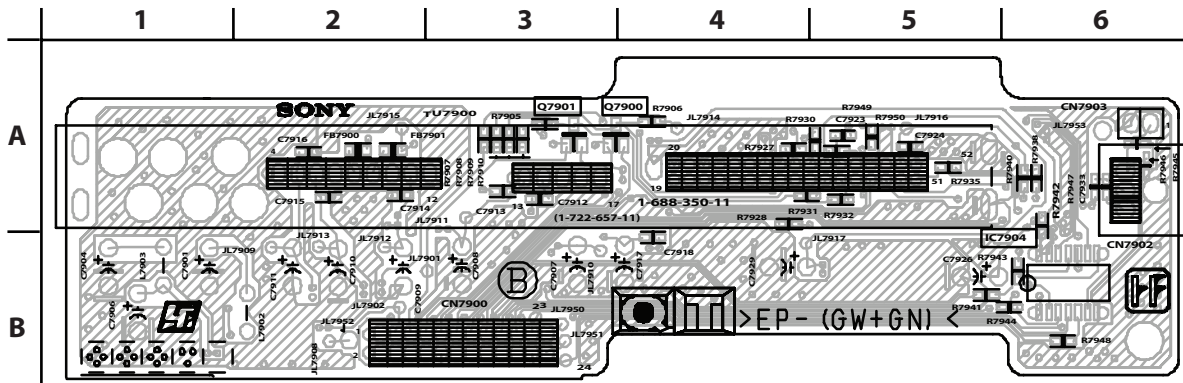

# HA BOARD SCHEMATIC DIAGRAM

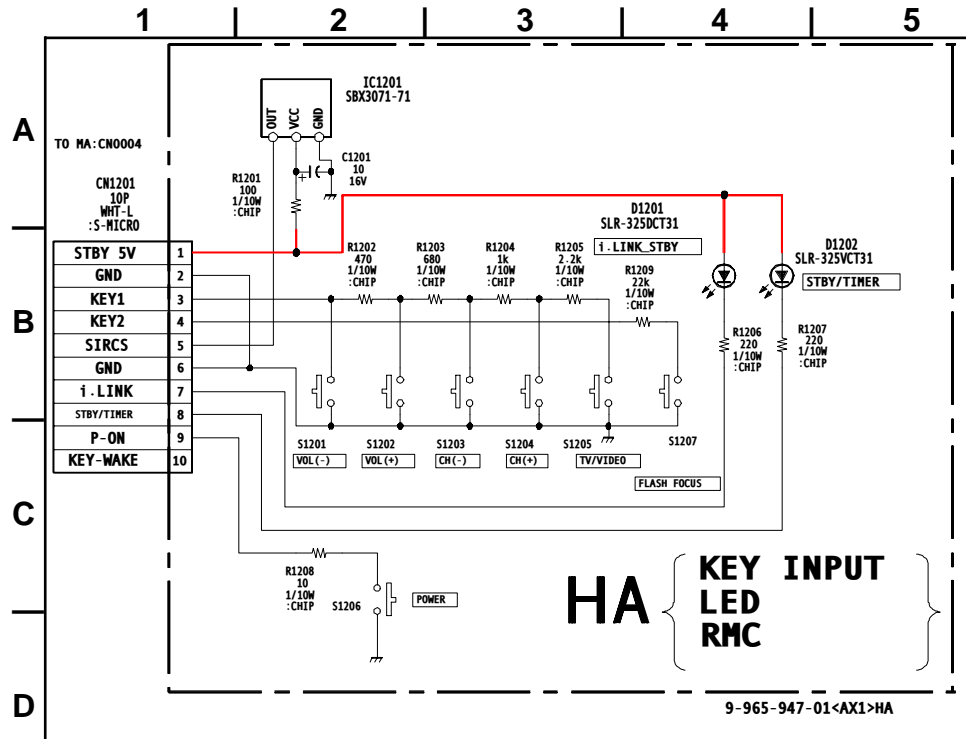

**HA** [KEY INPUT, LED, RMC]  
**COMPONENT SIDE**

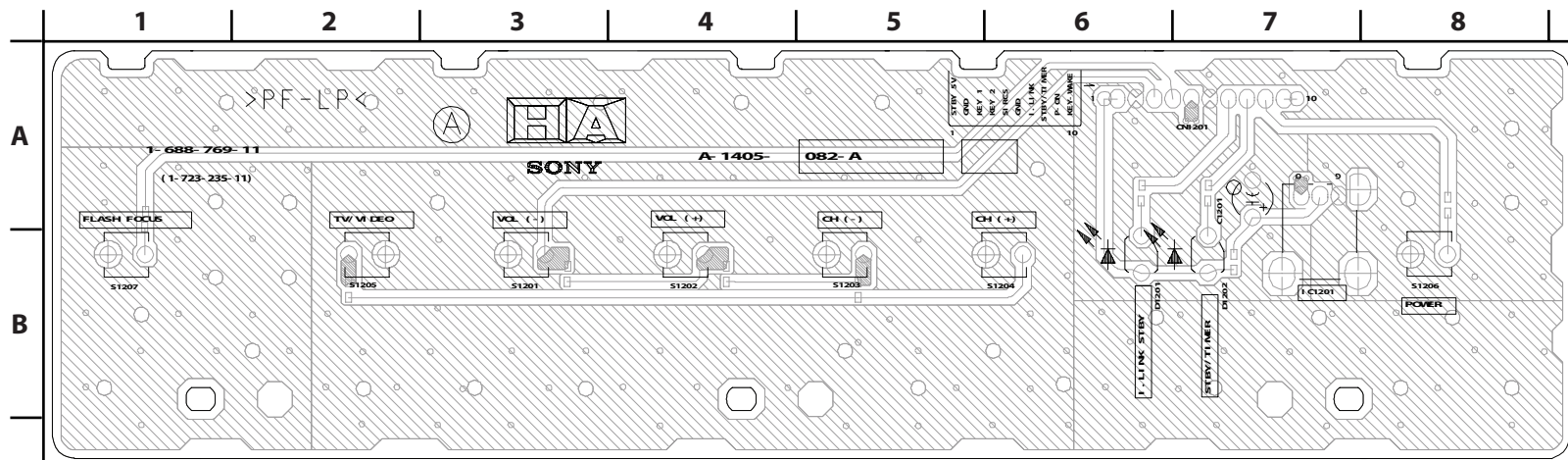

**HA** [KEY INPUT, LED, RMC]  
**CONDUCTOR SIDE**

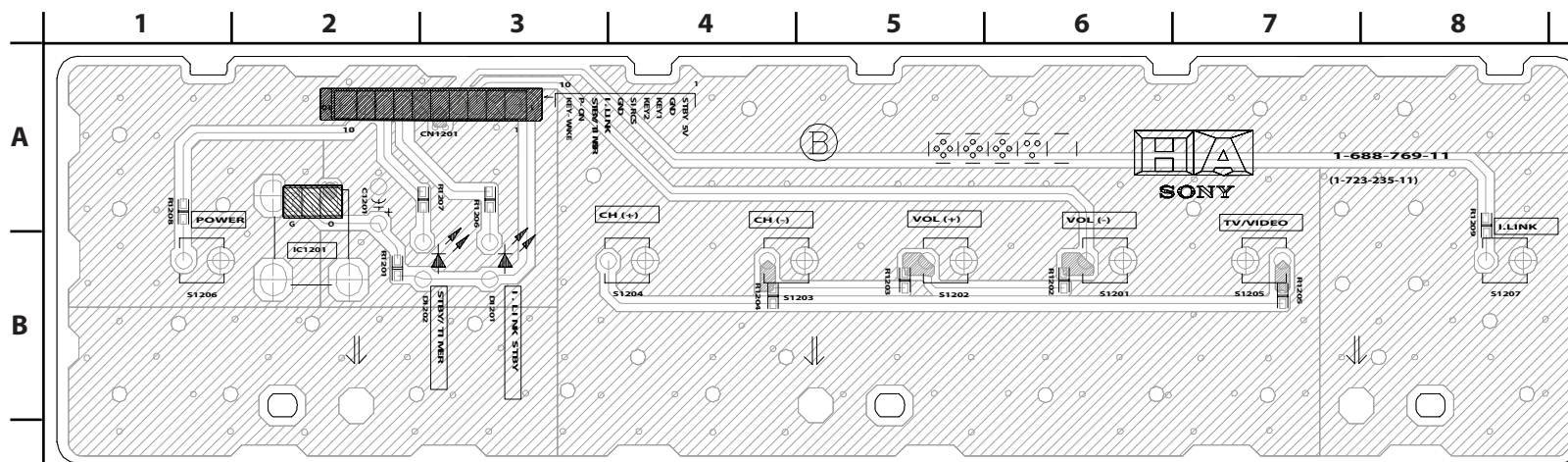

# QH BOARD SCHEMATIC DIAGRAM

Due to the complexity of this board, performing component level field repairs is not recommended. If service is required, complete board replacement is the preferred repair method. Data is provided for reference only.

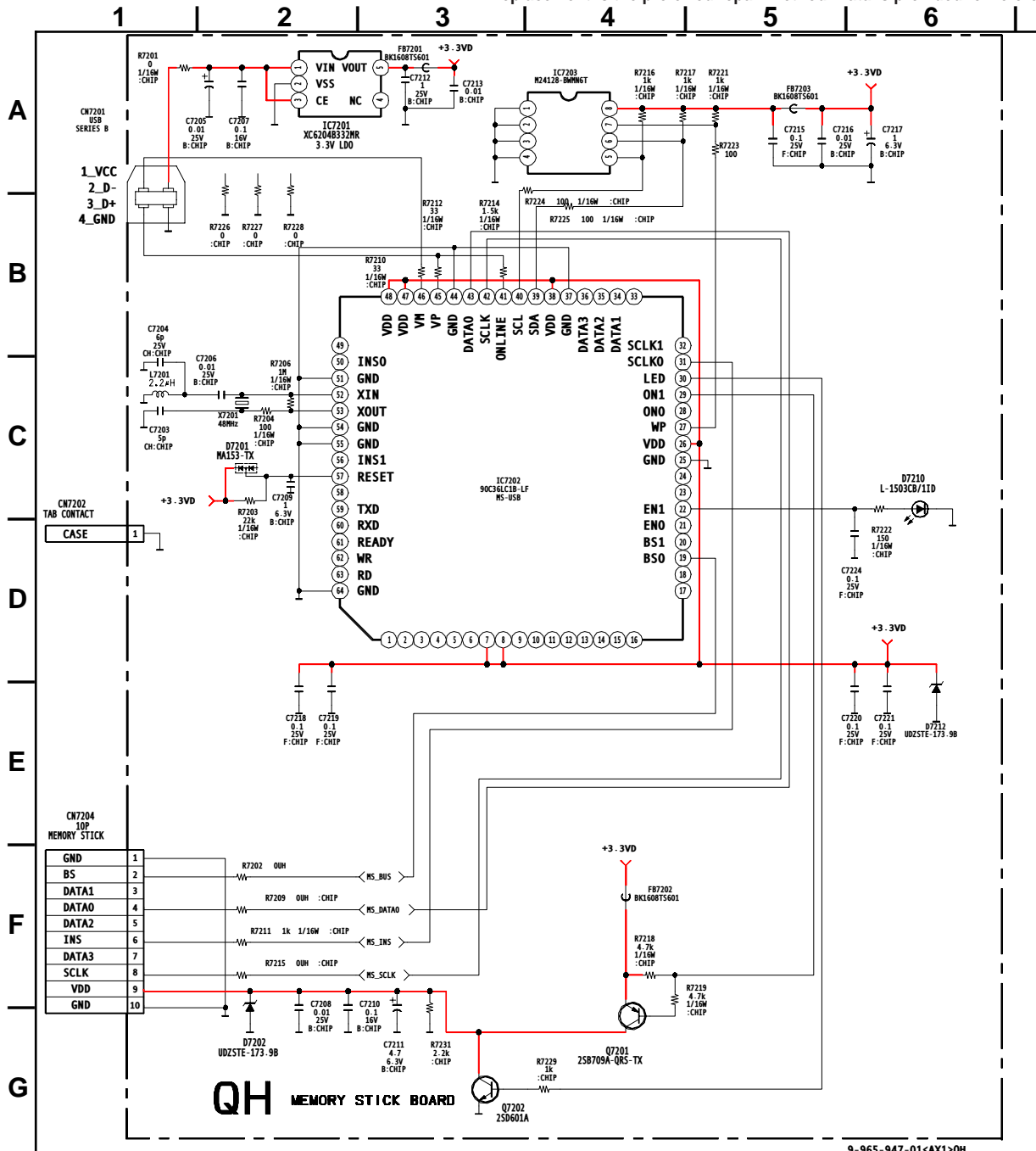

**QH** [MEMORY STICK BOARD]  
COMPONENT SIDE

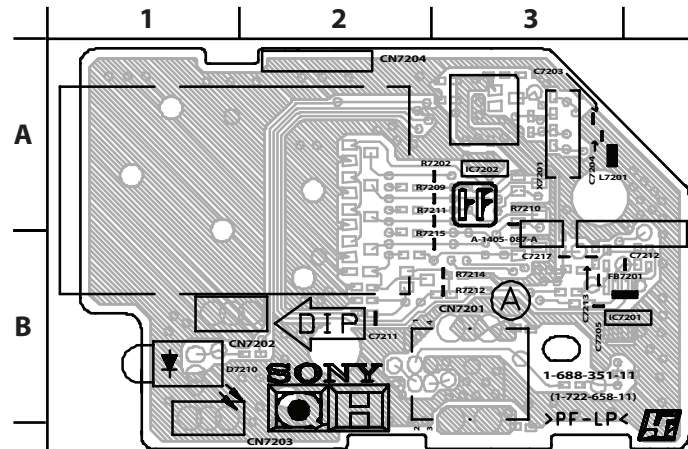

**QH** [MEMORY STICK BOARD]  
CONDUCTOR SIDE

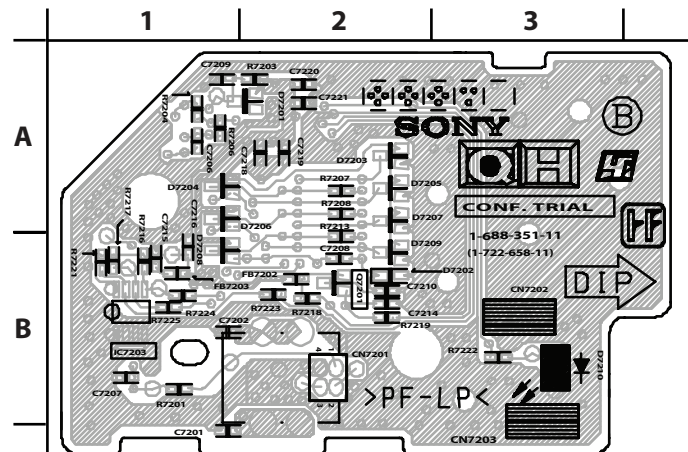

**SR BOARD SCHEMATIC DIAGRAM** Due to the complexity of this board, performing component level field repairs is not recommended. If service is required, complete board replacement is the preferred repair method. Data is provided for reference only.

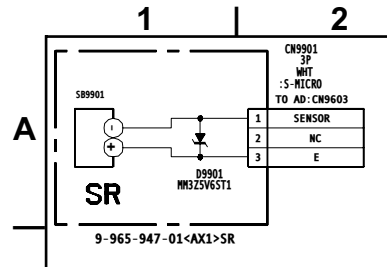

**SR** [SENSOR]  
COMPONENT SIDE

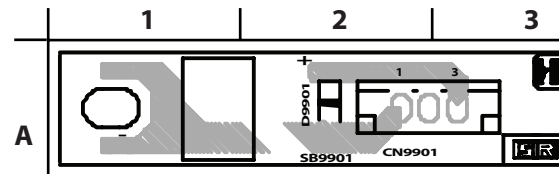

**SR** [SENSOR]  
CONDUCTOR SIDE

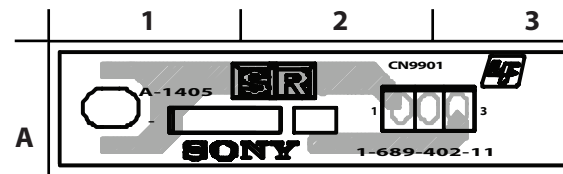



### HB BOARD SCHEMATIC DIAGRAM

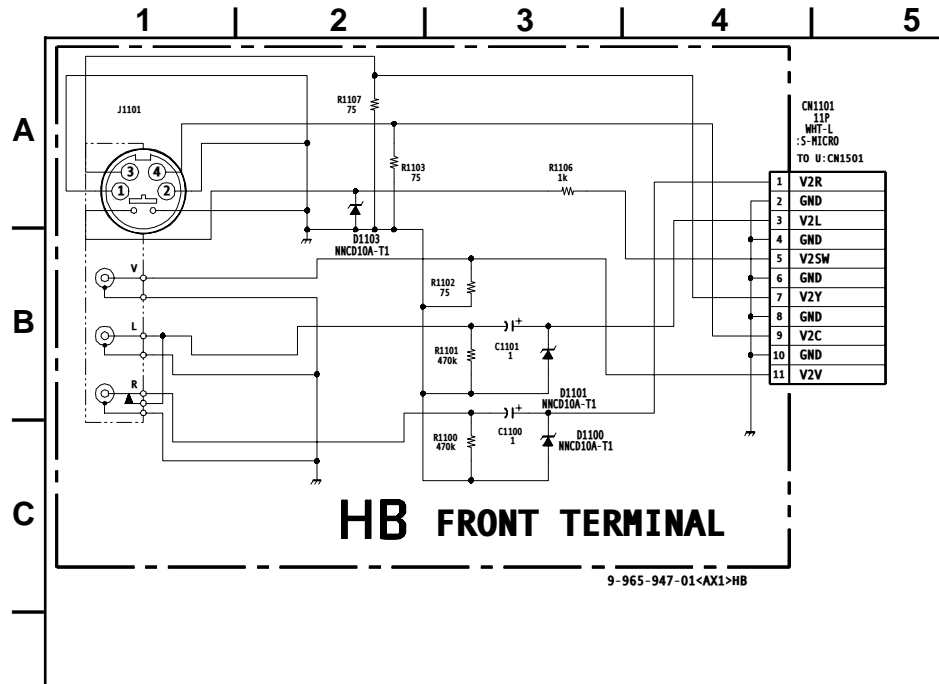

**HB** [FRONT TERMINAL]  
COMPONENT SIDE

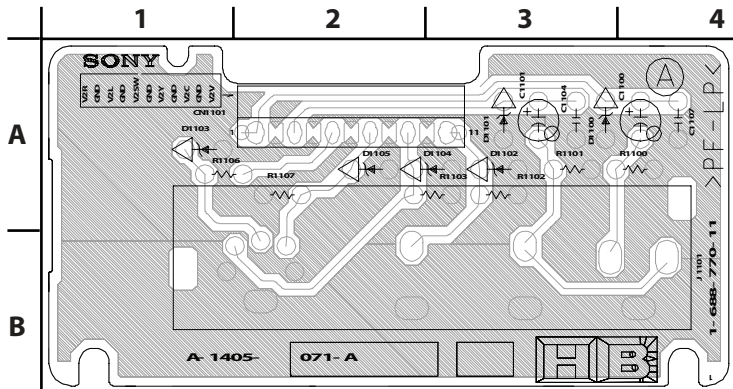

**HB** [FRONT TERMINAL]  
CONDUCTOR SIDE

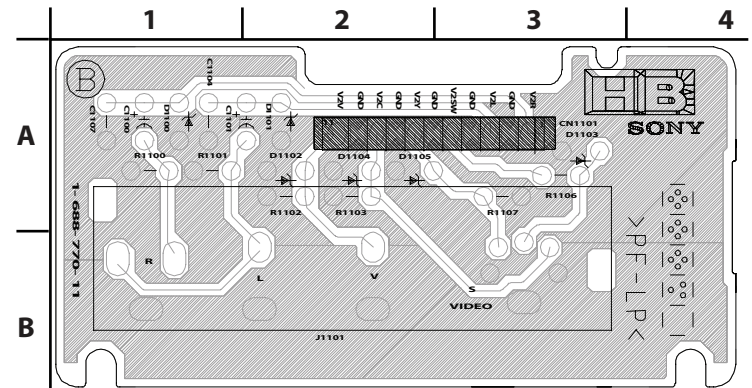

5-5. SEMICONDUCTORS

AN77L12-TA  
NJM78L12A-T3  
NJM79L05A  
NJM79L05A-T3

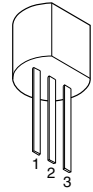

CXA2069Q  
CXA2150AQ

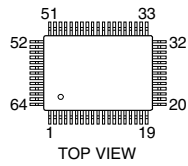

MAX4450EUK-TG069

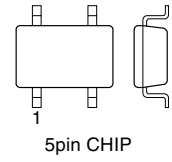

M24C04-WMN6T(A)  
M24C32-WMN6T(A)  
NJM2068V-TE2  
NJM2521M(Te2)  
NJM2903M  
NJM2903M-TE2  
NJM2904M  
NJM2904M(Te2)  
NJM4558M-T2  
NJM4558M-TE2  
NJM4558V-TE2  
µPC4558G2

PST9143NL

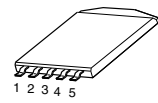

µPC393C

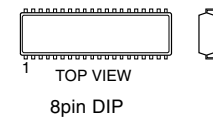

2SC5681-YB

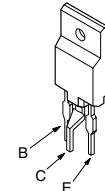

DTZ10B  
MA111-TX  
UDZ-TE-17- 8.2B  
UDZ-TE-17-7.5B  
UDZS-TE17-12B  
UDZS-TE17-22B  
UDZS-TE17-33B  
UDZSTE-1710B  
UDZSTE-1720B  
UDZSTE-175.1B  
UDZSTE-175.6B  
UDZSTE-177.5B  
UDZSTE-178.2B  
1SS355TE-17

D2L20U-F  
ERC04-06SE

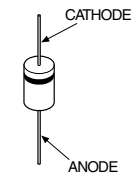

FMQ-G5FMS  
PG124S15

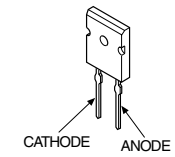

BA9759F-E2

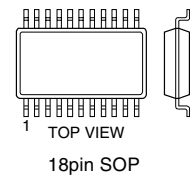

CXD2073Q-T4

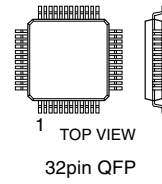

MCZ3001D

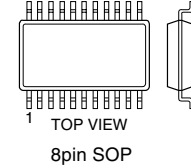
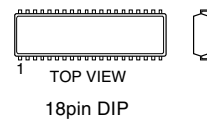

SBX1971-51P

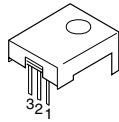

IRFIB7N50A-LF31

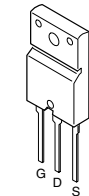

2SD2144S-TP-V  
2SD2144S-V

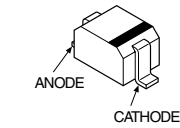
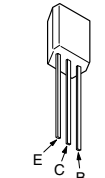

D2SB60A-F04  
D4SBS4-F  
D6SB60LF

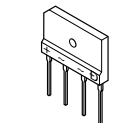

MTZJ-T-77-15B  
MTZJ-T-77-20B  
MTZJ-T-77-5.1B  
RD18ES-B2  
RD18ES-B2  
RD20ES-B2  
RD5.1ESB2  
RD5.6ESB2  
1SS133T-77

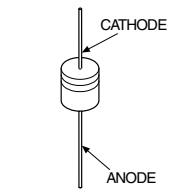

MC7805CT  
MC7812CT  
NJM7805FA  
NJM7812FA  
PQ09RF21  
TA7805S  
TA7812S

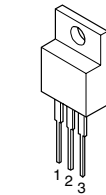

M52055FP  
TC74HCT157AF  
TC74HCT157AF(EL)  
TC74LVX157FT(EL)

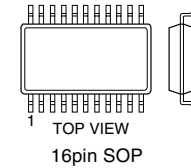

STK392-560

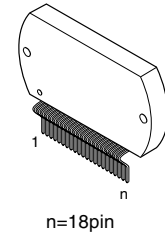

1MB12-140-F153A  
2SA2005  
2SC4634LS-CB11  
2SC5511

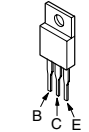

2SJ585LS-CC11

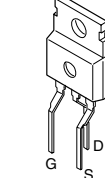

D1NL20U  
D1NL20U-TA2  
D2L20U  
D2L20U-TA  
EL1Z  
ERA22-08  
ERA22-08TP3  
GP08D  
GP08DPKG23  
MTZJ-T-77-18B  
MTZJ-T-77-22B  
MTZJ-T-77-5.6B  
RGP02-17EL-6433  
RGP02-17PKG23  
RGP10GPKG23  
S2L40F  
10ERA60-TP  
1SS83  
1SS83TD

D25SC6MF04

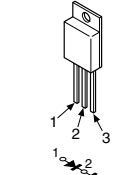

PC123F2  
PC123FY2

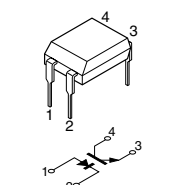

CD0031AM

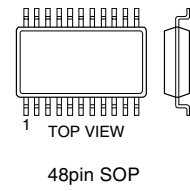

CXP961064-001Q  
M306V2ME-154FP  
µPD64082GF-3BA

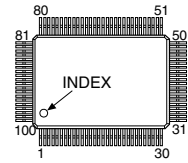

MM1476AF(TP)

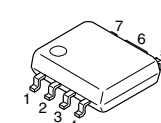

NJM2391DL1-33-TEI

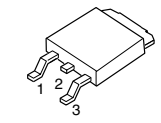

TDA6120Q/N2/S1

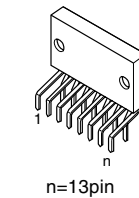

2SA1037AK-T146-QR  
2SA1037AK-T146-R  
2SA1226  
2SA1226-T1E3E4  
2SB709A-QRS-TX  
2SC1623-L5L6  
2SC2412K-T-146-QR  
2SD601A-Q  
2SD601A-QRS-TX



2SK2876-01MR-F122

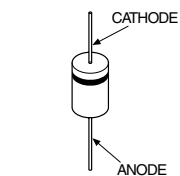
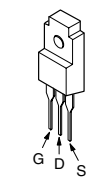

D25SC6MRF04

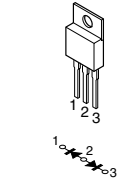

SLR-325VCT31

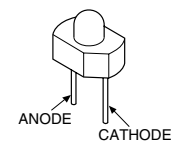

CM0017AF

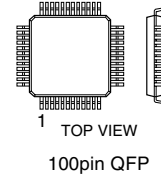

DM-58

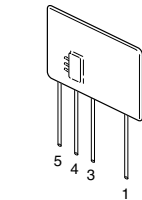

MSM514265C-60JS  
µPD424210LE-60-E2

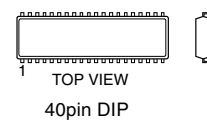

NJM2395AF05  
NJM2395F09

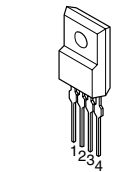

TDA7265

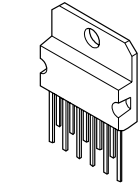

2SA1358-Y  
2SC3421-Y

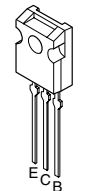

2SK3018-T106

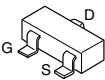

D10SC6M

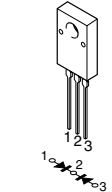

ERD07-15L

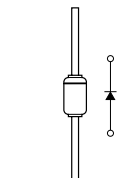

SPR-325MVW

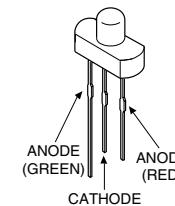

CXA1726AM  
CXA1726AM-T6

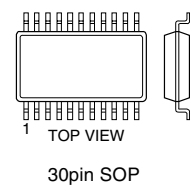

LA6500-FA  
LA6500P-FA

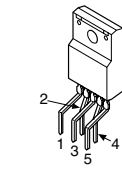

NJW1106FC2

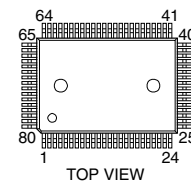

TDA7312

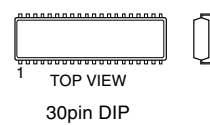

2SC2688(5)-LK

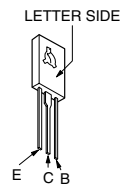

DAN202K  
DAN202K-T-146

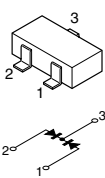

D10SC6MR

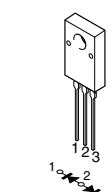

FCQ30A04

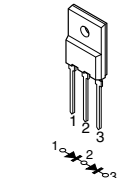

CXA2103Q  
CXA2151Q

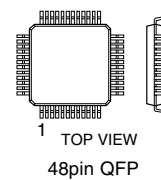

LA78045  
TDA2052

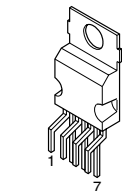

PQ30RV11

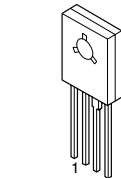

µPC1093J-1-T

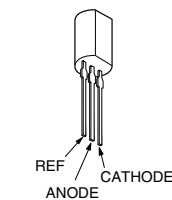

**SECTION 6: EXPLODED VIEWS**

Components not identified by a part number or description are not stocked because they are seldom required for routine service.

The component parts of an assembly are indicated by the reference numbers in the far right column of the parts list and within the dotted lines of the diagram.

\* Items marked with an asterisk are not stocked since they are seldom required for routine service. Expect some delay when ordering these components.

NOTE: The components identified by shading and  $\triangle$  mark are critical for safety. Replace only with part number specified.

NOTE: Les composants identifiés par un trame et une marque  $\triangle$  sont critiques pour la sécurité. Ne les remplacer que par une pièce portant le numéro spécifié.

**6-1. COVER (KDP-51WS550/57WS550 ONLY)**

- 7-685-648-79 SCREW +BVTP 3X12 TYPE2 IT-3
- 7-685-661-14 SCREW +BVTP 4X12 TYPE2 IT-3

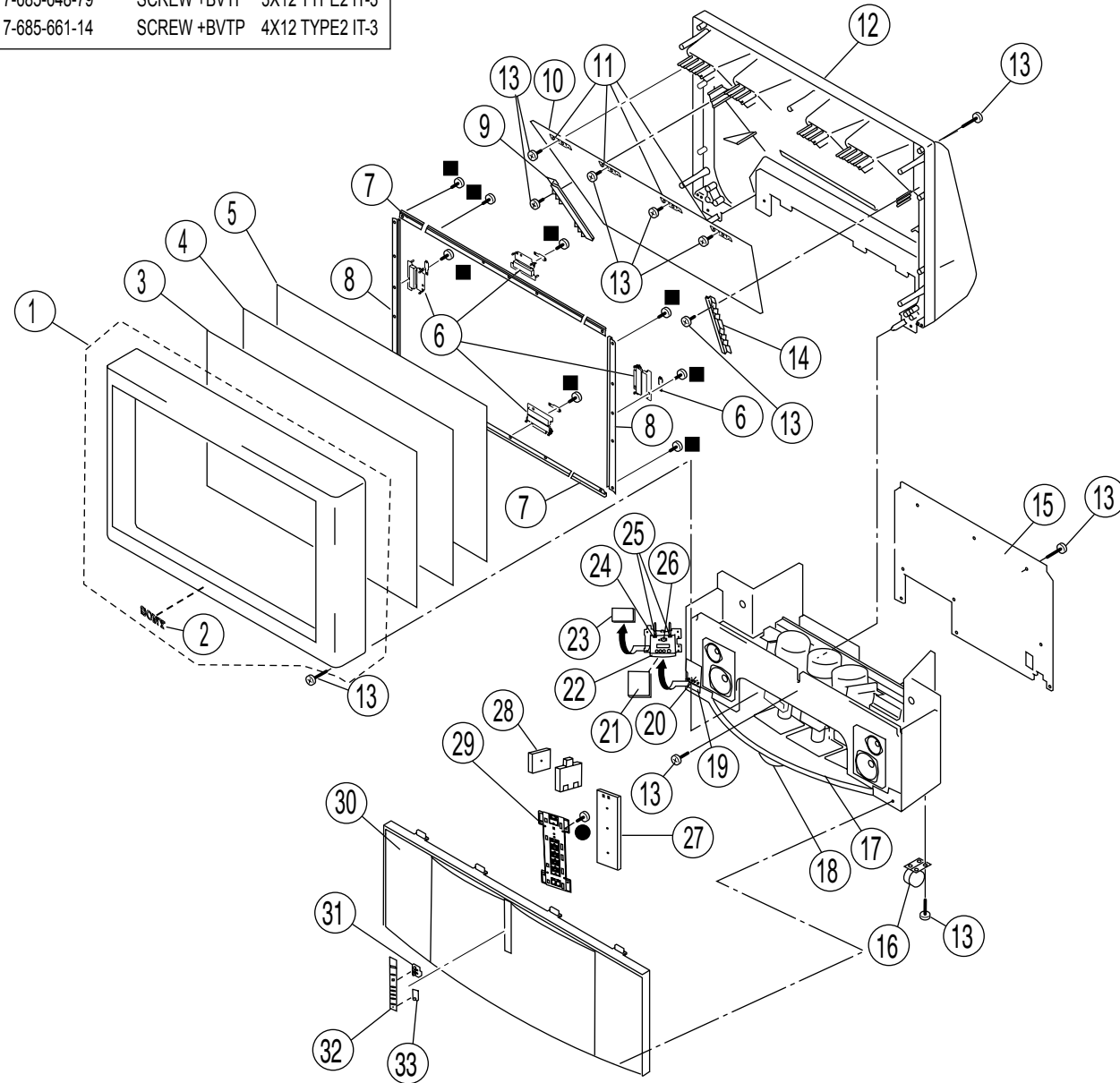

REF.NO.	PART NO.	DESCRIPTION	ASSEMBLY INCLUDES	REF.NO.	PART NO.	DESCRIPTION
1	X-4041-774-1	BEZEL (51) ASSEMBLY (KDP-51WS550 ONLY)	(2)	*	12	4-083-467-01 COVER (51), MIRROR (KDP-51WS550 ONLY)
1	X-4041-765-1	BEZEL (57) ASSEMBLY (KDP-57WS550 ONLY)	(2)	12	X-4039-824-1 COVER (57) ASSEMBLY, MIRROR (KDP-57WS550 ONLY)	
2	3-704-179-01	EMBLEM (NO.9), SONY (KDP-51WS550 ONLY)		13	4-081-063-01 SCREW, DOME WASHER HEX TAP 4X20	
2	4-381-079-01	EMBLEM (NO.10), SONY (KDP-57WS550 ONLY)		*	14	4-083-459-01 HOLDER (R), MIRROR SIDE (KDP-51WS550 ONLY)
3	4-081-954-11	SCREEN (51W), CONTRAST (KDP-51WS550 ONLY)		*	14	4-083-461-01 HOLDER (R), MIRROR SIDE (KDP-57WS550 ONLY)
3	4-086-327-11	SCREEN (57W), CONTRAST (KDP-57WS550 ONLY)		*	15	4-094-557-01 BOARD (51), REAR (KDP-51WS550 ONLY)
4	4-095-388-11	PLATE (51WL), DIFFUSION (KDP-51WS550 ONLY)		*	15	4-094-519-01 BOARD (57), REAR (KDP-57WS550 ONLY)
4	4-095-924-11	PLATE (57WL), DIFFUSION (KDP-57WS550 ONLY)		16	4-040-755-01 CASTER (DIA. 30) (KDP-51WS550/57WS550 ONLY)	
5	4-081-953-11	PLATE (51WFV), DIFFUSION (KDP-51WS550 ONLY)		17	4-094-558-01 SKIRT (51), FRONT (KDP-51WS550 ONLY)	
5	4-081-950-11	PLATE (57WFV), DIFFUSION (KDP-57WS550 ONLY)		17	4-094-520-01 SKIRT (57), FRONT (KDP-57WS550 ONLY)	
*	6	A-1405-083-A SR BOARD, MOUNTED		18	4-075-020-01 FOOT, PLASTIC	
*	7	4-084-617-02 HOLDER, SCREEN (KDP-51WS550 ONLY)		19	4-094-556-01 LABEL, INPUT TERMINAL	
*	7	4-084-568-02 HOLDER, SCREEN (KDP-57WS550 ONLY)		20	4-088-569-02 BRACKET, INPUT TERMINAL	
*	8	4-084-617-12 HOLDER, SCREEN (KDP-51WS550 ONLY)		21	4-088-571-02 PLATE, INPUT TERMINAL	
*	8	4-084-568-12 HOLDER, SCREEN (KDP-57WS550 ONLY)		22	3-973-975-41 DAMPER, OIL	
*	9	4-083-460-01 HOLDER (L), MIRROR SIDE (KDP-51WS550 ONLY)		*	23	A-1405-071-A HB BOARD, MOUNTED
*	9	4-083-462-01 HOLDER (L), MIRROR SIDE (KDP-57WS550 ONLY)		*	24	4-094-555-01 COVER, INPUT TERMINAL
10	4-084-615-01 MIRROR (51) (KDP-51WS550 ONLY)			25	4-088-573-01 SPRING	
10	4-084-561-02 MIRROR (57) (KDP-57WS550 ONLY)			26	4-047-464-01 CATCHER, PUSH	
*	11	4-081-501-01 HOLDER, MIRROR (KDP-51WS550/57WS550 ONLY)		*	27	A-1302-165-A QH BOARD, COMPLETE
				*	28	A-1405-082-A HA BOARD, MOUNTED
				29	4-094-562-01 BUTTON, MULTI	
				30	X-4041-773-1 GRILLE (51) ASSEMBLY, SPEAKER (KDP-51WS550 ONLY)	
				30	X-4041-767-1 GRILLE (57) ASSEMBLY, SPEAKER (KDP-57WS550 ONLY)	
				31	4-088-588-01 GUIDE (HM), LED	
				32	4-094-561-01 PANEL, CONTROL	
				33	4-088-586-01 GUIDE, LED	

**6-2. COVER (KDP-65WS550 ONLY)**

- 7-685-648-79 SCREW +BVTP 3X12 TYPE2 IT-3
- 7-685-661-14 SCREW +BVTP 4X12 TYPE2 IT-3
- ★ 4-378-522-11 SCREW, TAPPING, HEXAGON HEAD

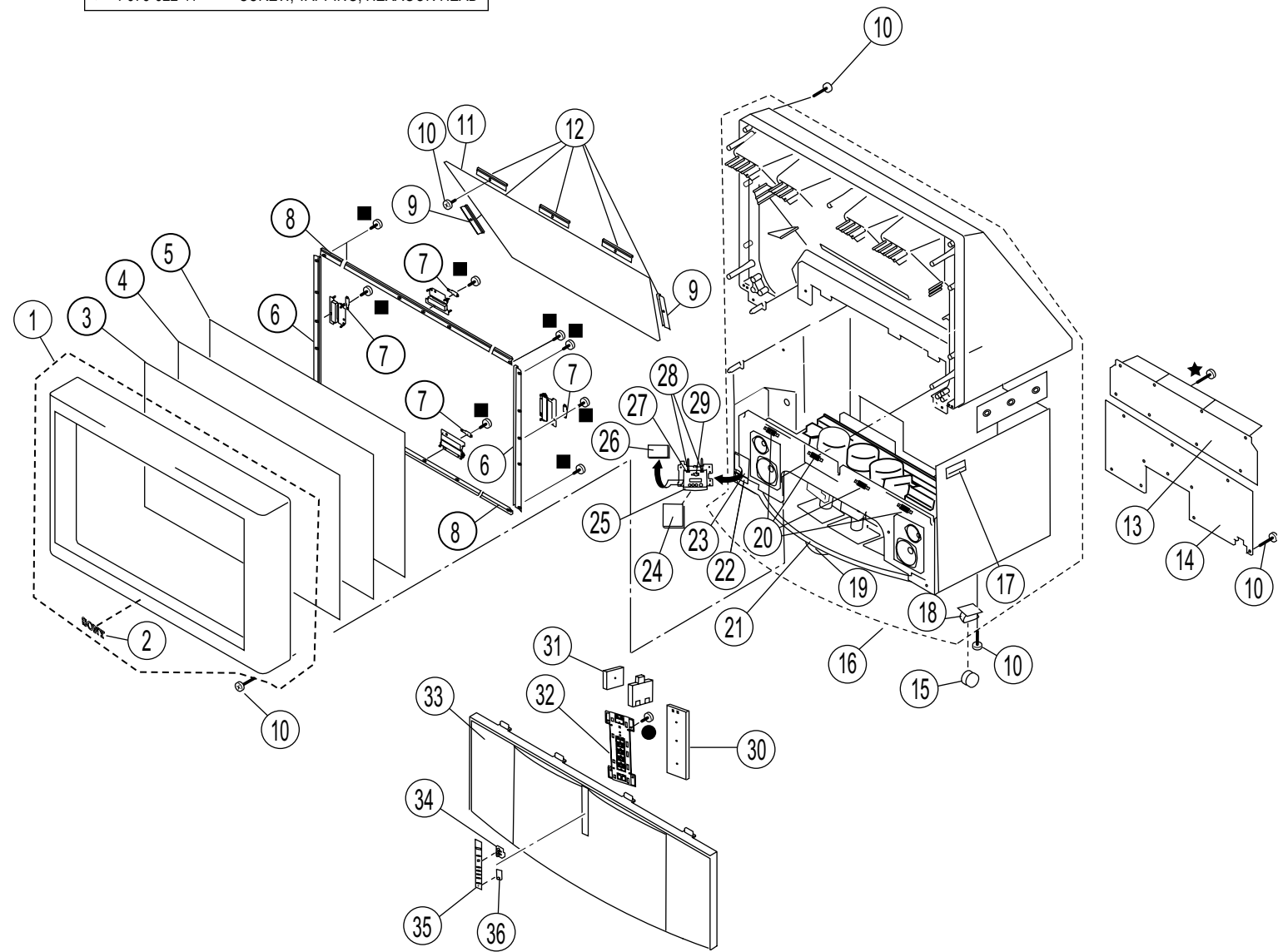

REF.NO.	PART NO.	DESCRIPTION	ASSEMBLY INCLUDES	REF.NO.	PART NO.	DESCRIPTION
1	X-4041-770-1	BEZNET (65) ASSEMBLY	(2)	21	4-094-526-01	SKIRT (65), FRONT
2	4-381-079-01	EMBLEM (NO.10), SONY		22	4-094-556-01	LABEL, INPUT TERMINAL
3	4-094-533-11	SCREEN (65W), CONTRAST		23	4-088-569-02	BRACKET, INPUT TERMINAL
4	4-089-151-11	PLATE (65WL), DIFFUSION		24	4-088-571-02	PLATE, INPUT TERMINAL
5	4-095-141-11	PLATE (65WFV), DIFFUSION		25	3-973-975-41	DAMPER, OIL
* 6	4-089-179-01	HOLDER (65 SHORT), SCREEN		* 26	A-1405-071-A	HB BOARD, MOUNTED
* 7	A-1405-083-A	SR BOARD, MOUNTED		* 27	4-094-555-01	COVER, INPUT TERMINAL
* 8	4-088-461-01	HOLDER, SCREEN		28	4-088-573-01	SPRING
9	4-088-579-01	HOLDER, MIRROR SLIDE		29	4-047-464-01	CATCHER, PUSH
10	4-081-063-01	SCREW, DOME WASHER HEX TAP 4X20		* 30	A-1302-165-A	QH BOARD, COMPLETE
* 11	4-088-577-01	MIRROR		* 31	A-1405-082-A	HA BOARD, MOUNTED
* 12	4-088-580-01	HOLDER, MIRROR BASE		32	4-094-562-01	BUTTON, MULTI
* 13	4-095-958-01	BOARD, REAR TOP (65)		33	X-4041-769-2	GRILLE (65) ASSEMBLY, SPEAKER
* 14	4-094-527-01	BOARD (65) BOTTOM, REAR		34	4-088-588-01	GUIDE (HM), LED
15	4-061-174-01	CASTER		35	4-094-561-01	PANEL, CONTROL
* 16	X-4041-768-1	CABINET ASSEMBLY (65)	(17-20)	36	4-088-586-01	GUIDE, LED
* 17	4-088-541-01	HANDLE				
18	4-030-850-01	SOCKET, CASTER				
19	4-075-020-01	FOOT, PLASTIC				
* 20	4-094-879-01	H-CATCH				

NOTE: The components identified by shading and  $\triangle$  mark are critical for safety. Replace only with part number specified.

NOTE: Les composants identifiés par un triangle et une marque  $\triangle$  sont critiques pour la sécurité. Ne les remplacer que par une pièce portant le numéro spécifié.

6-3. CHASSIS

- 7-685-648-79 SCREW +BVTP 3X12 TYPE2 IT-3
- 7-685-661-14 SCREW +BVTP 4X12 TYPE2 IT-3
- ★ 4-382-854-01 SCREW (M3X8), P, SW (+)

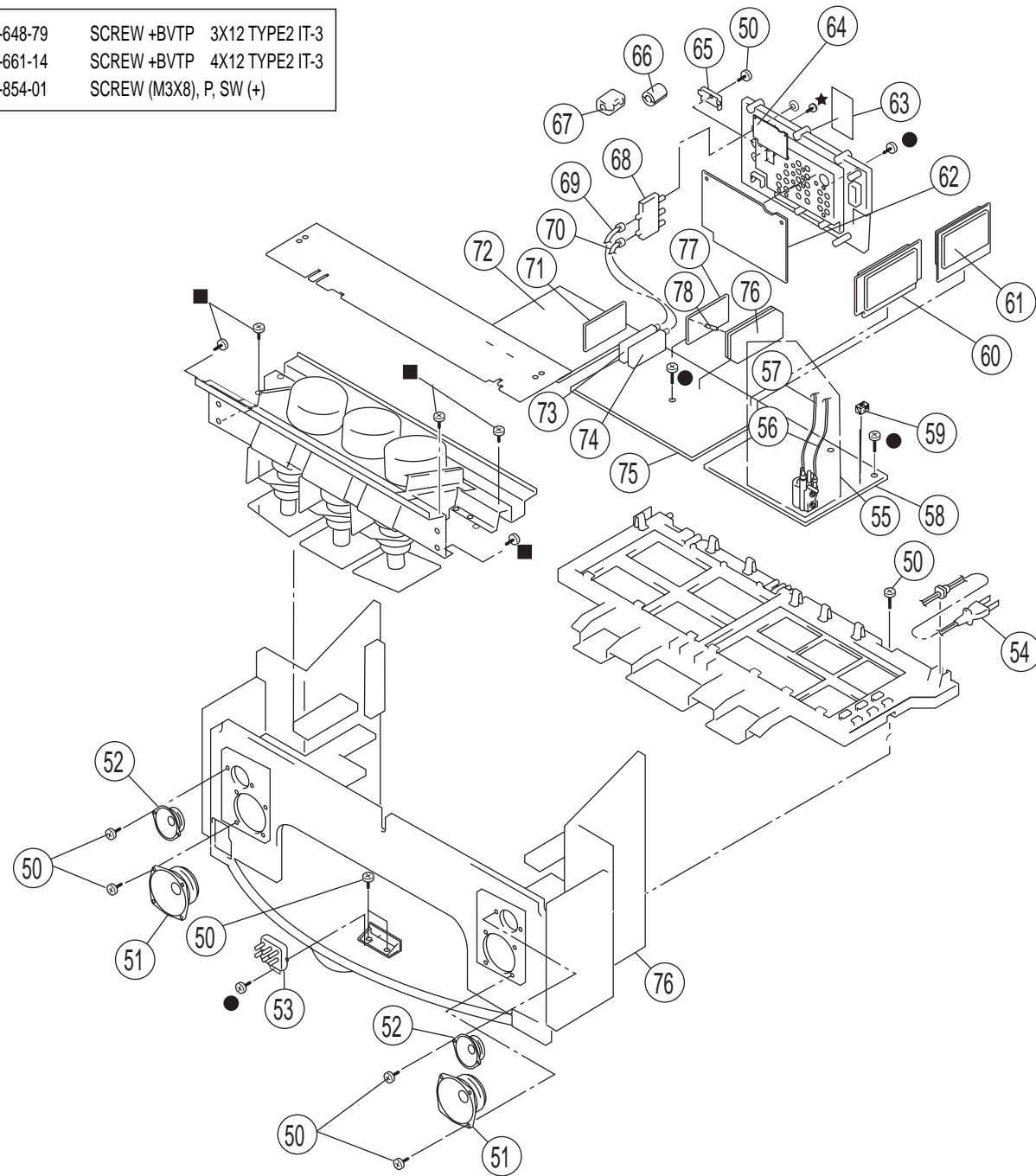

REF.NO.	PART NO.	DESCRIPTION	ASSEMBLY INCLUDES	REF.NO.	PART NO.	DESCRIPTION
50	4-081-063-01	SCREW, DOME WASHER HEX TAP 4X20		65	4-069-675-01	CAP, TERMINAL BOARD
51	1-825-525-11	LOUDSPEAKER (13CM)		66	1-469-241-11	CORE, FERRITE (RFC-8 BK)
52	1-529-403-41	LOUDSPEAKER (6.6CM)		67	1-500-497-11	FILTER, CLAMP (FERRITE CORE)
$\triangle$ 53	1-223-925-34	RESISTOR ASSEMBLY (HIGH-VOLTAGE)		$\triangle$ 68	1-786-183-12	SWITCH, ANTENNA
$\triangle$ 54	1-769-837-11	CORD, POWER (WITH NOISE FILTER)		*	1-557-056-31	CABLE, P-P
$\triangle$ 55	1-453-450-11	FBT ASSEMBLY NX-6030/M3A4 (56-57)		*	1-555-110-00	CABLE, PIN
$\triangle$ 56	1-779-095-51	LEAD ASSEMBLY, HIGH-VOLTAGE		71	A-1302-160-A	AD BOARD, COMPLETE
$\triangle$ 57	1-900-260-40	CONNECTOR ASSEMBLY, MV		*	A-1405-077-A	DS BOARD, MOUNTED
*	A-1302-161-A	D BOARD, COMPLETE		73	8-598-593-20	TUNER, FSS BTF-WA421
The high-voltage leads associated with the FBT on the D board are not included and must be ordered separately. (See 56-57)				74	8-598-594-10	TUNER, FSS BTF-FA421
59	3-710-578-01	COVER, VOLUME, 6 MOLD		*	A-1302-158-A	A BOARD, COMPLETE
*	A-1302-353-A	BM BOARD, COMPLETE		☞ 76	A-1606-712-A	Q BOX (51RP) ASSEMBLY (KDP-51WS550 ONLY)
*	A-1302-157-A	MA BOARD, COMPLETE		☞ 76	A-1606-710-A	Q BOX (57RP) ASSEMBLY (KDP-57WS550 ONLY)
*	A-1302-159-A	UA BOARD, COMPLETE		☞ 76	A-1606-711-A	Q BOX (65RP) ASSEMBLY (KDP-65WS550 ONLY)
63	4-094-552-01	LABEL, TERMINAL		If it is determined that the Q Box Assembly has malfunctioned it must be replaced as a Complete Assembly. The boards within this assembly, QI, QM, and QT, are not field repairable. The following data is for reference only.		
*	A-1302-352-A	UD BOARD, COMPLETE		*	A-1302-164-A	QI COMPLETE PC BOARD
				*	A-1302-554-A	QM COMPLETE PC BOARD
				*	A-1302-541-A	QT COMPLETE PC BOARD
				*	A-1405-081-A	G2 BOARD, MOUNTED
				78	4-385-948-41	HOLDER, PWB

NOTE: The components identified by shading and  $\triangle$  mark are critical for safety. Replace only with part number specified.

NOTE: Les composants identifiés par un trame et une marque  $\triangle$  sont critiques pour la sécurité. Ne les remplacer que par une pièce portant le numéro spécifié.

6-4. PICTURE TUBE

- 7-685-648-79 SCREW +BVTP 3X12 TYPE2 IT-3
- 7-685-661-14 SCREW +BVTP 4X12 TYPE2 IT-3

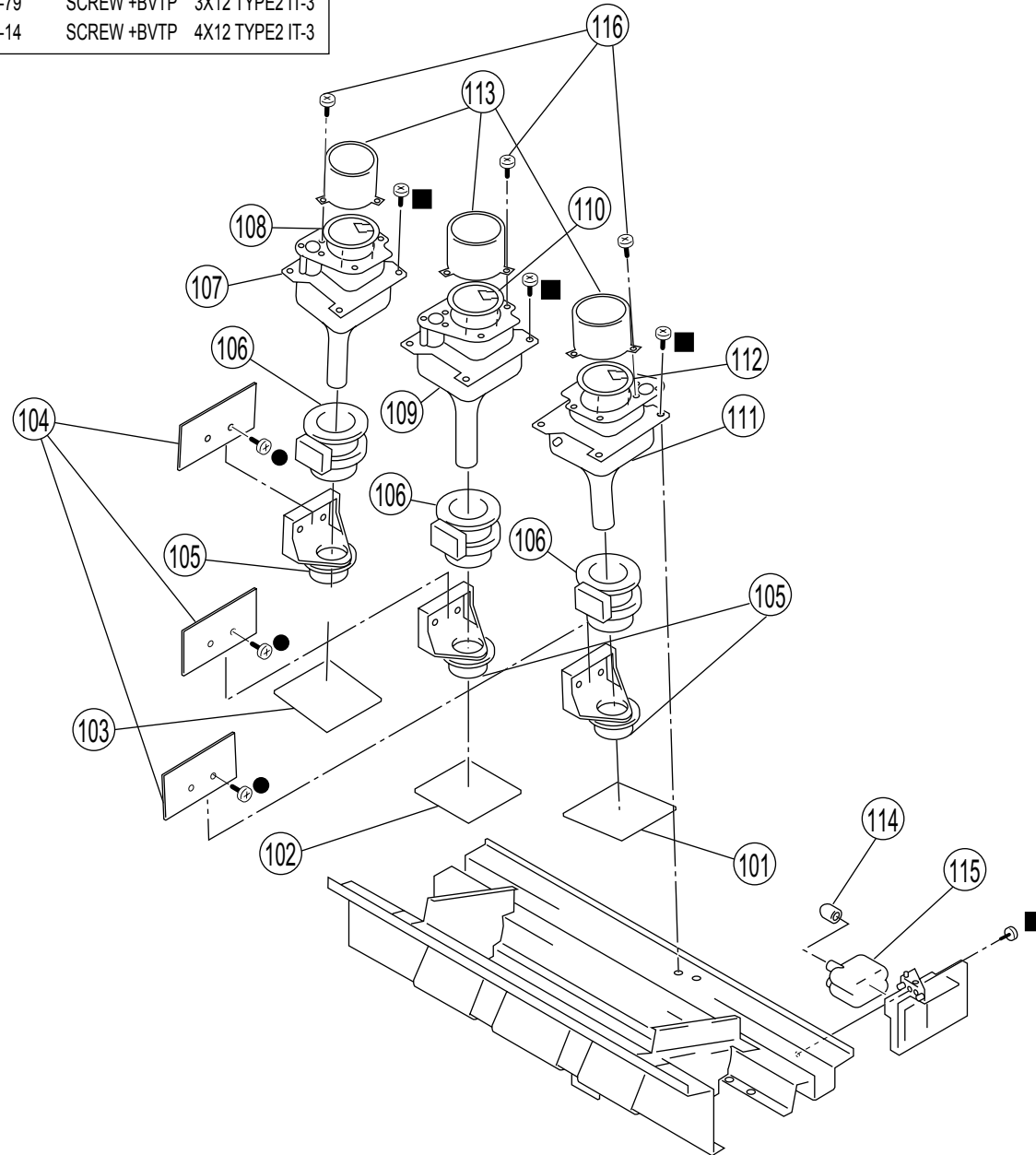

REF.NO.	PART NO.	DESCRIPTION	REF.NO.	PART NO.	DESCRIPTION
* 101	A-1405-080-A	CB BOARD, MOUNTED	$\triangle$ 111	A-1604-485-A	COUPLER (R) ASSEMBLY, CRT (KDP-51WS550 ONLY)
* 102	A-1405-079-A	CG BOARD, MOUNTED	$\triangle$ 111	A-1604-491-A	COUPLER (R) ASSEMBLY, CRT (KDP-57WS550 ONLY)
* 103	A-1405-078-A	CR BOARD, MOUNTED	$\triangle$ 111	A-1604-497-A	COUPLER (R) ASSEMBLY, CRT (KDP-65WS550 ONLY)
* 104	A-1405-662-A	VM BOARD, MOUNTED			
105	1-451-535-12	COIL ASSEMBLY, VM			
$\triangle$ 106	1-451-542-31	DEFLECTION YOKE			
$\triangle$ 107	A-1604-487-A	COUPLER (B) ASSEMBLY, CRT (KDP-51WS550 ONLY)	112	4-096-118-01	SHADE (51-R) (KDP-51WS550 ONLY)
$\triangle$ 107	A-1604-493-A	COUPLER (B) ASSEMBLY, CRT (KDP-57WS550 ONLY)	112	4-096-145-01	SHADE, RED (KDP-57WS550/65WS550 ONLY)
$\triangle$ 107	A-1604-499-A	COUPLER (B) ASSEMBLY, CRT (KDP-65WS550 ONLY)	113	4-083-751-01	LENS (DELTA 250) (KDP-51WS550 ONLY)
108	4-096-146-01	SHADE, BLUE (KDP-57WS550 ONLY)	113	4-096-100-01	LENS (DELTA260TCM) (KDP-57WS550 ONLY)
$\triangle$ 109	A-1604-483-A	COUPLER (G) ASSEMBLY, CRT	113	4-096-104-01	LENS (DELTA270TCM) (KDP-65WS550 ONLY)
110	4-096-119-01	SHADE (51-G) (KDP-51WS550/57WS550 ONLY)	114	4-373-137-01	CAP (Z), RUBBER
110	4-097-791-01	SHADE (G) (KDP-65WS550 ONLY)	$\triangle$ 115	8-598-875-00	BLOCK ASSEMBLY, HIGH-VOLTAGE
			116	7-685-663-71	SCREW +BVTP 4X16 TYPE2 IT-3

## SECTION 7: ELECTRICAL PARTS LIST

NOTE: The components identified by shading and  $\triangle$  mark are critical for safety. Replace only with part number specified.

NOTE: Les composants identifiés par un trame et une marque  $\triangle$  sont critiques pour la sécurité. Ne les remplacer que par une pièce portant le numéro spécifié.

The components in this manual identified by the following symbol:  $\boxtimes$  indicate parts that have been carefully factory-selected to satisfy regulations regarding X-ray radiation for each set.

Should replacement be required for one of these components, replace only with the value originally used.

\* Items marked with an asterisk are not stocked since they are seldom required for routine service. Expect some delay when ordering these components.

## RESISTORS

- All resistors are in ohms
- F : nonflammable
- All variable and adjustable resistors have characteristic curve B, unless otherwise noted.

CR

When ordering parts by reference number, please include the board name.

REF.NO.	PART NO.	DESCRIPTION	VALUES	REF.NO.	PART NO.	DESCRIPTION	VALUES
<div style="border: 1px solid black; padding: 2px; display: inline-block; font-weight: bold; font-size: 1.2em;">CR</div>				<u>IC</u>			
				IC9101	8-759-680-01	IC	TDA6120Q/N2/S1
* <b>A-1405-078-A CR BOARD, MOUNTED</b> 4-382-854-11 SCREW (M3X10), P, SW (+)				<u>JACK</u>			
				$\triangle$ J9101	1-251-182-11	SOCKET, CRT	
<u>CAPACITOR</u> C9101 1-104-570-11 CERAMIC 0.001 $\mu$ F 10% 2KV C9102 1-162-919-11 CERAMIC CHIP 22pF 5% 50V C9103 1-164-156-11 CERAMIC CHIP 0.1 $\mu$ F 25V C9105 1-107-962-11 ELECT 22 $\mu$ F 20% 250V C9106 1-161-830-00 CERAMIC 0.0047 $\mu$ F 500V C9107 1-101-003-00 CERAMIC 0.0047 $\mu$ F 50V C9108 1-126-935-11 ELECT 470 $\mu$ F 20% 16V C9110 1-164-156-11 CERAMIC CHIP 0.1 $\mu$ F 25V C9111 1-164-156-11 CERAMIC CHIP 0.1 $\mu$ F 25V C9112 1-126-933-11 ELECT 100 $\mu$ F 20% 16V C9114 1-162-966-11 CERAMIC CHIP 0.0022 $\mu$ F 10% 50V C9115 1-101-003-00 CERAMIC 0.0047 $\mu$ F 50V C9117 1-164-156-11 CERAMIC CHIP 0.1 $\mu$ F 25V				<u>COIL</u>			
				L9101	1-414-856-11	INDUCTOR	10 $\mu$ H
	L9102	1-414-855-31	INDUCTOR	1 $\mu$ H			
	L9103	1-414-856-11	INDUCTOR	10 $\mu$ H			
<u>CONNECTOR</u> * CN9101 1-564-510-11 PLUG, CONNECTOR 7P * CN9102 1-564-507-11 PLUG, CONNECTOR 4P * CN9103 1-564-508-11 PLUG, CONNECTOR 5P CN9104 1-695-915-11 TAB (CONTACT) CN9107 1-785-879-11 CONNECTOR, ONE TOUCH CN9110 1-695-915-11 TAB (CONTACT)				<u>NEON LAMP</u>			
				$\triangle$ NL9102	1-517-778-21	LAMP, NEON	
	NL9103	1-517-778-21	LAMP, NEON				
<u>DIODE</u> D9101 8-719-970-83 DIODE HSS82-TJ D9104 8-719-970-83 DIODE HSS82-TJ D9109 8-719-081-97 DIODE MMDL914T1				<u>TRANSISTOR</u>			
				Q9101	8-729-010-29	TRANSISTOR	MSD601-RST1
				Q9102	8-729-028-28	TRANSISTOR	2SK2036(TE85L)
				Q9103	8-729-010-05	TRANSISTOR	MSB709-RT1
				Q9104	8-729-010-05	TRANSISTOR	MSB709-RT1
				Q9105	8-729-122-63	TRANSISTOR	2SA1226-E4
<u>FERRITE BEAD</u> FB9101 1-469-578-11 FERRITE 1.1 $\mu$ H				<u>RESISTOR</u>			
				R9101	1-260-133-11	CARBON	680K 5% 1/2W
				R9102	1-249-425-11	CARBON	4.7K 5% 1/4W
				R9103	1-216-809-11	METAL CHIP	100 5% 1/10W
				R9104	1-260-132-11	CARBON	560K 5% 1/2W
				R9105	1-218-851-11	METAL CHIP	1.5K 0.50% 1/10W
				R9106	1-218-835-11	METAL CHIP	330 0.50% 1/10W
				R9107	1-216-825-11	METAL CHIP	2.2K 5% 1/10W
				R9108	1-218-871-11	METAL CHIP	10K 0.50% 1/10W
				R9109	1-218-845-11	METAL CHIP	820 0.50% 1/10W
				R9114	1-218-855-11	METAL CHIP	2.2K 0.50% 1/10W
				R9115	1-218-863-11	METAL CHIP	4.7K 0.50% 1/10W
R9116	1-260-328-11	CARBON	1K 5% 1/2W				

**NOTE: The components identified by shading and  $\triangle$  mark are critical for safety. Replace only with part number specified.**

**NOTE: Les composants identifiés par un triangle et une marque  $\triangle$  sont critiques pour la sécurité. Ne les remplacer que par une pièce portant le numéro spécifié.**



REF.NO.	PART NO.	DESCRIPTION	VALUES		
R9120	1-243-624-71	METAL OXIDE	33K	5%	3W
R9122	1-260-320-11	CARBON	220	5%	1/2W
R9126	1-218-903-11	METAL CHIP	220K	0.50%	1/10W
R9127	1-218-903-11	METAL CHIP	220K	0.50%	1/10W
R9129	1-216-829-11	METAL CHIP	4.7K	5%	1/10W
R9131	1-216-823-11	METAL CHIP	1.5K	5%	1/10W
R9132	1-216-833-11	METAL CHIP	10K	5%	1/10W
R9133	1-216-809-11	METAL CHIP	100	5%	1/10W
R9134	1-216-821-11	METAL CHIP	1K	5%	1/10W
R9135	1-260-087-11	CARBON	100	5%	1/2W
R9136	1-218-855-11	METAL CHIP	2.2K	0.50%	1/10W
R9137	1-218-855-11	METAL CHIP	2.2K	0.50%	1/10W
R9147	1-216-864-11	SHORT CHIP			
<b>SPARK GAP</b>					
SG9101	1-518-925-31	GAP, SPARK			
SG9102	1-519-422-11	GAP, SPARK			
SG9103	1-519-422-11	GAP, SPARK			
<b>CG BOARD, MOUNTED</b>					
* A-1405-079-A	4-382-854-11	SCREW (M3X10), P, SW (+)			
<b>CAPACITOR</b>					
C9201	1-107-662-11	ELECT	22 $\mu$ F	20%	350V
C9202	1-104-570-11	CERAMIC	0.001 $\mu$ F	10%	2KV
C9203	1-164-156-11	CERAMIC CHIP	0.1 $\mu$ F		25V
C9204	1-126-935-11	ELECT	470 $\mu$ F	20%	16V
C9205	1-164-378-11	CERAMIC CHIP	30pF	5%	50V
C9207	1-164-156-11	CERAMIC CHIP	0.1 $\mu$ F		25V
C9208	1-164-156-11	CERAMIC CHIP	0.1 $\mu$ F		25V
C9209	1-101-003-00	CERAMIC	0.0047 $\mu$ F		50V
C9211	1-126-933-11	ELECT	100 $\mu$ F	20%	16V
C9213	1-161-830-00	CERAMIC	0.0047 $\mu$ F		500V
C9214	1-162-966-11	CERAMIC CHIP	0.0022 $\mu$ F	10%	50V
C9216	1-101-003-00	CERAMIC	0.0047 $\mu$ F		50V
C9217	1-164-156-11	CERAMIC CHIP	0.1 $\mu$ F		25V
<b>CONNECTOR</b>					
* CN9201	1-564-510-11	PLUG, CONNECTOR	7P		
* CN9202	1-564-510-11	PLUG, CONNECTOR	7P		
* CN9203	1-564-507-11	PLUG, CONNECTOR	4P		
* CN9204	1-564-507-11	PLUG, CONNECTOR	4P		
* CN9205	1-564-506-11	PLUG, CONNECTOR	3P		

REF.NO.	PART NO.	DESCRIPTION	VALUES		
CN9208	1-695-915-11	TAB (CONTACT)			
CN9209	1-785-879-11	CONNECTOR, ONE TOUCH			
CN9210	1-695-915-11	TAB (CONTACT)			
<b>DIODE</b>					
D9201	8-719-970-83	DIODE			HSS82-TJ
D9206	8-719-970-83	DIODE			HSS82-TJ
D9209	8-719-081-97	DIODE			MMDL914T1
<b>FERRITE BEAD</b>					
FB9201	1-469-578-11	FERRITE			1.1 $\mu$ H
<b>IC</b>					
IC9201	8-759-680-01	IC			TDA6120Q/N2/S1
<b>JACK</b>					
$\triangle$ J9201	1-251-182-11	SOCKET, CRT			
<b>COIL</b>					
L9201	1-414-856-11	INDUCTOR			10 $\mu$ H
L9202	1-414-855-31	INDUCTOR			1 $\mu$ H
L9203	1-414-856-11	INDUCTOR			10 $\mu$ H
<b>NEON LAMP</b>					
$\triangle$ NL9202	1-517-778-21	LAMP, NEON			
NL9203	1-517-778-21	LAMP, NEON			
<b>TRANSISTOR</b>					
Q9201	8-729-010-29	TRANSISTOR			MSD601-RST1
Q9202	8-729-028-28	TRANSISTOR			2SK2036(TE85L)
Q9203	8-729-010-05	TRANSISTOR			MSB709-RT1
Q9204	8-729-122-63	TRANSISTOR			2SA1226-E4
<b>RESISTOR</b>					
R9201	1-260-133-11	CARBON	680K	5%	1/2W
R9202	1-260-132-11	CARBON	560K	5%	1/2W
R9203	1-249-425-11	CARBON	4.7K	5%	1/4W
R9204	1-216-809-11	METAL CHIP	100	5%	1/10W
R9205	1-218-871-11	METAL CHIP	10K	0.50%	1/10W
R9206	1-218-832-11	METAL CHIP	240	0.50%	1/10W
R9207	1-218-849-11	METAL CHIP	1.2K	0.50%	1/10W
R9208	1-216-825-11	METAL CHIP	2.2K	5%	1/10W
R9209	1-218-845-11	METAL CHIP	820	0.50%	1/10W
R9216	1-218-854-11	METAL CHIP	2K	0.50%	1/10W



NOTE: The components identified by shading and  $\triangle$  mark are critical for safety. Replace only with part number specified.

NOTE: Les composants identifiés par un trame et une marque  $\triangle$  sont critiques pour la sécurité. Ne les remplacer que par une pièce portant le numéro spécifique.



REF.NO.	PART NO.	DESCRIPTION	VALUES			REF.NO.	PART NO.	DESCRIPTION	VALUES		
R9217	1-218-863-11	METAL CHIP	4.7K	0.50%	1/10W	CN9308	1-785-879-11	CONNECTOR, ONE TOUCH			
R9220	1-243-624-71	METAL OXIDE	33K	5%	3W	* CN9309	1-564-507-11	PLUG, CONNECTOR	4P		
R9221	1-260-328-11	CARBON	1K	5%	1/2W	CN9310	1-695-915-11	TAB (CONTACT)			
R9223	1-260-320-11	CARBON	220	5%	1/2W						
R9225	1-218-899-11	METAL CHIP	150K	0.50%	1/16W						
R9226	1-218-899-11	METAL CHIP	150K	0.50%	1/16W						
R9228	1-216-829-11	METAL CHIP	4.7K	5%	1/10W						
R9230	1-216-823-11	METAL CHIP	1.5K	5%	1/10W						
R9231	1-260-087-11	CARBON	100	5%	1/2W						
R9232	1-218-855-11	METAL CHIP	2.2K	0.50%	1/10W						
R9233	1-218-855-11	METAL CHIP	2.2K	0.50%	1/10W						
<b>SPARK GAP</b>											
SG9201	1-518-925-31	GAP, SPARK									
SG9202	1-519-422-11	GAP, SPARK									
SG9203	1-519-422-11	GAP, SPARK									
<b>CAPACITOR</b>											
C9301	1-104-570-11	CERAMIC	0.001 $\mu$ F	10%	2KV						
C9302	1-101-003-00	CERAMIC	0.0047 $\mu$ F		50V						
C9303	1-107-662-11	ELECT	22 $\mu$ F	20%	350V						
C9304	1-162-920-11	CERAMIC CHIP	27pF	5%	50V						
C9305	1-162-916-11	CERAMIC CHIP	12pF	5%	50V						
C9306	1-164-156-11	CERAMIC CHIP	0.1 $\mu$ F		25V						
C9307	1-126-935-11	ELECT	470 $\mu$ F	20%	16V						
C9309	1-164-156-11	CERAMIC CHIP	0.1 $\mu$ F		25V						
C9310	1-164-156-11	CERAMIC CHIP	0.1 $\mu$ F		25V						
C9311	1-126-933-11	ELECT	100 $\mu$ F	20%	16V						
C9312	1-161-830-00	CERAMIC	0.0047 $\mu$ F		500V						
C9313	1-164-156-11	CERAMIC CHIP	0.1 $\mu$ F		25V						
C9314	1-162-970-11	CERAMIC CHIP	0.01 $\mu$ F	10%	25V						
C9315	1-162-966-11	CERAMIC CHIP	0.0022 $\mu$ F	10%	50V						
C9316	1-101-003-00	CERAMIC	0.0047 $\mu$ F		50V						
C9318	1-164-156-11	CERAMIC CHIP	0.1 $\mu$ F		25V						
C9320	1-125-891-11	CERAMIC CHIP	0.47 $\mu$ F	10%	10V						
<b>CONNECTOR</b>											
* CN9301	1-564-510-11	PLUG, CONNECTOR	7P								
* CN9302	1-564-510-11	PLUG, CONNECTOR	7P								
* CN9303	1-564-507-11	PLUG, CONNECTOR	4P								
CN9304	1-695-915-11	TAB (CONTACT)									
<b>DIODE</b>											
D9301	8-719-081-97	DIODE								MMDL914T1	
D9302	8-719-970-83	DIODE								HSS82-TJ	
D9303	8-719-081-97	DIODE								MMDL914T1	
D9305	6-500-029-01	DIODE								MM3Z12VST1	
D9309	8-719-970-83	DIODE								HSS82-TJ	
<b>FERRITE BEAD</b>											
FB9301	1-469-578-11	FERRITE								1.1 $\mu$ H	
<b>IC</b>											
IC9301	8-759-680-01	IC								TDA6120Q/N2/S1	
<b>JACK</b>											
$\triangle$ J9301	1-251-182-11	SOCKET, CRT									
<b>COIL</b>											
L9301	1-414-856-11	INDUCTOR								10 $\mu$ H	
L9302	1-414-855-31	INDUCTOR								1 $\mu$ H	
L9303	1-414-856-11	INDUCTOR								10 $\mu$ H	
<b>NEON LAMP</b>											
$\triangle$ NL9302	1-517-778-21	LAMP, NEON									
NL9303	1-517-778-21	LAMP, NEON									
<b>TRANSISTOR</b>											
Q9301	8-729-010-05	TRANSISTOR								MSB709-RT1	
Q9302	8-729-028-28	TRANSISTOR								2SK2036(TE85L)	
Q9304	8-729-010-29	TRANSISTOR								MSD601-RST1	
Q9305	8-729-010-05	TRANSISTOR								MSB709-RT1	
Q9306	8-729-010-05	TRANSISTOR								MSB709-RT1	
Q9307	8-729-010-05	TRANSISTOR								MSB709-RT1	
Q9309	8-729-122-63	TRANSISTOR								2SA1226-E4	
Q9311	8-729-010-29	TRANSISTOR								MSD601-RST1	
<b>RESISTOR</b>											
R9301	1-216-809-11	METAL CHIP	100	5%	1/10W						
R9302	1-216-864-11	SHORT CHIP									
R9303	1-260-133-11	CARBON	680K	5%	1/2W						
R9304	1-260-132-11	CARBON	560K	5%	1/2W						
R9306	1-218-831-11	METAL CHIP	220	0.50%	1/10W						



\* **A-1405-080-A** **CB BOARD, MOUNTED**  
4-382-854-11 SCREW (M3X10), P, SW (+)



REF.NO.	PART NO.	DESCRIPTION	VALUES			REF.NO.	PART NO.	DESCRIPTION	VALUES		
R9307	1-218-851-11	METAL CHIP	1.5K	0.50%	1/10W						
R9308	1-218-839-11	METAL CHIP	470	0.50%	1/10W						
R9309	1-218-849-11	METAL CHIP	1.2K	0.50%	1/10W						
R9313	1-218-877-11	METAL CHIP	18K	0.50%	1/10W						
R9314	1-218-862-11	METAL CHIP	4.3K	0.50%	1/10W						
R9315	1-218-859-11	METAL CHIP	3.3K	0.50%	1/10W						
R9316	1-218-853-11	METAL CHIP	1.8K	0.50%	1/10W						
R9317	1-218-863-11	METAL CHIP	4.7K	0.50%	1/10W						
R9318	1-216-825-11	METAL CHIP	2.2K	5%	1/10W						
R9319	1-249-425-11	CARBON	4.7K	5%	1/4W						
R9320	1-243-624-71	METAL OXIDE	33K	5%	3W						
R9323	1-260-328-11	CARBON	1K	5%	1/2W						
R9325	1-260-320-11	CARBON	220	5%	1/2W						
R9327	1-218-904-11	METAL CHIP	240K	0.50%	1/10W						
R9328	1-218-904-11	METAL CHIP	240K	0.50%	1/10W						
R9330	1-216-829-11	METAL CHIP	4.7K	5%	1/10W						
R9332	1-216-823-11	METAL CHIP	1.5K	5%	1/10W						
R9333	1-218-854-11	METAL CHIP	2K	0.50%	1/10W						
R9334	1-216-822-11	METAL CHIP	1.2K	5%	1/10W						
R9335	1-249-393-11	CARBON	10	5%	1/4W						
R9339	1-260-087-11	CARBON	100	5%	1/2W						
R9340	1-218-871-11	METAL CHIP	10K	0.50%	1/10W						
R9342	1-216-834-11	METAL CHIP	12K	5%	1/10W						
R9343	1-216-832-11	METAL CHIP	8.2K	5%	1/10W						
R9344	1-216-845-11	METAL CHIP	100K	5%	1/10W						
R9345	1-218-863-11	METAL CHIP	4.7K	0.50%	1/10W						
R9346	1-216-833-11	METAL CHIP	10K	5%	1/10W						
R9347	1-216-821-11	METAL CHIP	1K	5%	1/10W						
R9348	1-216-821-11	METAL CHIP	1K	5%	1/10W						
R9349	1-216-809-11	METAL CHIP	100	5%	1/10W						
R9350	1-218-855-11	METAL CHIP	2.2K	0.50%	1/10W						
R9351	1-218-855-11	METAL CHIP	2.2K	0.50%	1/10W						
R9352	1-216-864-11	SHORT CHIP									
R9355	1-216-809-11	METAL CHIP	100	5%	1/10W						
R9356	1-216-809-11	METAL CHIP	100	5%	1/10W						
<b>SPARK GAP</b>											
SG9301	1-518-925-31	GAP, SPARK									
SG9302	1-519-422-11	GAP, SPARK									
SG9303	1-519-422-11	GAP, SPARK									
											
						* <b>A-1405-662-A</b> <b>VM BOARD, MOUNTED</b>					
						4-382-854-11 SCREW (M3X10), P, SW (+)					
						<b>CAPACITOR</b>					
						C9001 1-126-933-11 ELECT 100µF 20% 16V					
						C9002 1-164-156-11 CERAMIC CHIP 0.1µF 25V					
						C9003 1-162-964-11 CERAMIC CHIP 0.001µF 10% 50V					
						C9004 1-107-645-11 ELECT 22µF 20% 200V					
						C9006 1-161-830-00 CERAMIC 0.0047µF 500V					
						C9007 1-164-156-11 CERAMIC CHIP 0.1µF 25V					
						C9008 1-126-964-11 ELECT 10µF 20% 50V					
						C9009 1-107-636-11 ELECT 10µF 20% 160V					
						C9010 1-137-528-11 MYLAR 0.1µF 10% 250V					
						C9011 1-107-826-11 CERAMIC CHIP 0.1µF 10% 16V					
						C9012 1-137-528-11 MYLAR 0.1µF 10% 250V					
						C9013 1-164-156-11 CERAMIC CHIP 0.1µF 25V					
						C9014 1-117-450-11 MYLAR 0.47µF 10% 250V					
						<b>CONNECTOR</b>					
						* CN9001 1-564-508-11 PLUG, CONNECTOR 5P					
						* CN9002 1-564-506-11 PLUG, CONNECTOR 3P					
						* CN9003 1-770-723-11 CONNECTOR, BOARD TO BOARD 8P					
						<b>FERRITE BEAD</b>					
						FB9001 1-469-869-21 FERRITE 0µH					
						FB9002 1-469-869-21 FERRITE 0µH					
						<b>CHIP CONDUCTOR</b>					
						JR9001 1-216-864-11 SHORT CHIP					
						JR9002 1-216-864-11 SHORT CHIP					
						<b>TRANSISTOR</b>					
						Q9001 8-729-422-27 TRANSISTOR 2SD601A-Q					
						Q9002 8-729-422-27 TRANSISTOR 2SD601A-Q					
						Q9003 8-729-422-27 TRANSISTOR 2SD601A-Q					
						Q9004 8-729-424-02 TRANSISTOR 2SB709A-QRS-TX					
						Q9005 8-729-422-27 TRANSISTOR 2SD601A-Q					
						Q9006 8-729-424-02 TRANSISTOR 2SB709A-QRS-TX					
						Q9007 8-729-422-27 TRANSISTOR 2SD601A-Q					
						Q9008 8-729-424-02 TRANSISTOR 2SB709A-QRS-TX					
						Q9009 8-729-422-27 TRANSISTOR 2SD601A-Q					
						Q9010 8-729-424-02 TRANSISTOR 2SB709A-QRS-TX					



REF.NO.	PART NO.	DESCRIPTION	VALUES			REF.NO.	PART NO.	DESCRIPTION	VALUES		
Q9011	8-729-045-05	TRANSISTOR	2SA2005			C0006	1-162-963-11	CERAMIC CHIP	680pF	10%	50V
Q9012	8-729-045-04	TRANSISTOR	2SC5511			C0007	1-162-963-11	CERAMIC CHIP	680pF	10%	50V
<b>RESISTOR</b>											
R9001	1-249-381-11	CARBON	1	5%	1/4W	C0008	1-164-156-11	CERAMIC CHIP	0.1μF		25V
R9002	1-216-820-11	METAL CHIP	820	5%	1/10W	C0009	1-164-505-11	CERAMIC CHIP	2.2μF		16V
R9003	1-216-819-11	METAL CHIP	680	5%	1/10W	C0010	1-126-933-11	ELECT	100μF	20%	16V
R9004	1-216-834-11	METAL CHIP	12K	5%	1/10W	C0011	1-164-156-11	CERAMIC CHIP	0.1μF		25V
R9005	1-216-839-11	METAL CHIP	33K	5%	1/10W	C0012	1-164-230-11	CERAMIC CHIP	220pF	5%	50V
R9006	1-216-811-11	METAL CHIP	150	5%	1/10W	C0013	1-115-416-11	CERAMIC CHIP	0.001μF	5%	25V
R9008	1-216-815-11	METAL CHIP	330	5%	1/10W	C0014	1-126-934-11	ELECT	220μF	20%	16V
R9009	1-216-813-11	METAL CHIP	220	5%	1/10W	C0015	1-164-156-11	CERAMIC CHIP	0.1μF		25V
R9010	1-216-813-11	METAL CHIP	220	5%	1/10W	C0016	1-115-416-11	CERAMIC CHIP	0.001μF	5%	25V
R9011	1-249-391-11	CARBON	6.8	5%	1/4W	C0017	1-164-230-11	CERAMIC CHIP	220pF	5%	50V
R9012	1-249-391-11	CARBON	6.8	5%	1/4W	C0018	1-126-933-11	ELECT	100μF	20%	16V
R9013	1-249-391-11	CARBON	6.8	5%	1/4W	C0019	1-164-505-11	CERAMIC CHIP	2.2μF		16V
R9014	1-249-391-11	CARBON	6.8	5%	1/4W	C0020	1-164-156-11	CERAMIC CHIP	0.1μF		25V
R9015	1-249-391-11	CARBON	6.8	5%	1/4W	C0021	1-164-156-11	CERAMIC CHIP	0.1μF		25V
R9016	1-249-391-11	CARBON	6.8	5%	1/4W	C0022	1-162-920-11	CERAMIC CHIP	27pF	5%	50V
R9017	1-249-391-11	CARBON	6.8	5%	1/4W	C0023	1-162-919-11	CERAMIC CHIP	22pF	5%	50V
R9018	1-249-391-11	CARBON	6.8	5%	1/4W	C0024	1-164-156-11	CERAMIC CHIP	0.1μF		25V
R9019	1-216-848-11	METAL CHIP	180K	5%	1/10W	C0025	1-162-918-11	CERAMIC CHIP	18pF	5%	50V
R9020	1-216-829-11	METAL CHIP	4.7K	5%	1/10W	C0026	1-162-918-11	CERAMIC CHIP	18pF	5%	50V
R9021	1-216-805-11	METAL CHIP	47	5%	1/10W	C0027	1-164-156-11	CERAMIC CHIP	0.1μF		25V
R9022	1-216-805-11	METAL CHIP	47	5%	1/10W	C0028	1-162-919-11	CERAMIC CHIP	22pF	5%	50V
R9023	1-216-829-11	METAL CHIP	4.7K	5%	1/10W	C0029	1-162-910-11	CERAMIC CHIP	5pF	0.25pF	50V
R9024	1-216-848-11	METAL CHIP	180K	5%	1/10W	C0030	1-115-156-11	CERAMIC CHIP	1μF		10V
R9025	1-215-890-11	METAL OXIDE	470	5%	2W	C0031	1-164-156-11	CERAMIC CHIP	0.1μF		25V
R9026	1-216-847-11	METAL CHIP	150K	5%	1/10W	C0032	1-164-156-11	CERAMIC CHIP	0.1μF		25V
R9027	1-216-847-11	METAL CHIP	150K	5%	1/10W	C0033	1-164-156-11	CERAMIC CHIP	0.1μF		25V
<b>MA</b>											
<p><b>Due to the complexity of this board, performing component level field repairs is not recommended. If service is required, complete board replacement is the preferred repair method. Data is provided for reference only.</b></p>						<p>C0034 1-164-156-11 CERAMIC CHIP 0.1μF 25V</p> <p>C0035 1-126-767-11 ELECT 1000μF 20% 16V</p>					
<p>* A-1302-157-A MA BOARD, COMPLETE</p>						<p>C0036 1-126-933-11 ELECT 100μF 20% 16V</p> <p>C0038 1-162-916-11 CERAMIC CHIP 12pF 5% 50V</p> <p>C0040 1-162-916-11 CERAMIC CHIP 12pF 5% 50V</p> <p>C0041 1-162-907-11 CERAMIC CHIP 2pF 0.25pF 50V</p> <p>C0042 1-164-245-11 CERAMIC CHIP 0.015μF 10% 25V</p>					
<b>CAPACITOR</b>											
C0001	1-164-156-11	CERAMIC CHIP	0.1μF		25V	C0044	1-164-156-11	CERAMIC CHIP	0.1μF		25V
C0002	1-162-968-11	CERAMIC CHIP	0.0047μF	10%	50V	C0045	1-126-933-11	ELECT	100μF	20%	16V
C0003	1-107-826-11	CERAMIC CHIP	0.1μF	10%	16V	C0046	1-164-156-11	CERAMIC CHIP	0.1μF		25V
C0004	1-107-826-11	CERAMIC CHIP	0.1μF	10%	16V	C0047	1-126-933-11	ELECT	100μF	20%	16V
C0005	1-162-968-11	CERAMIC CHIP	0.0047μF	10%	50V	C0048	1-164-156-11	CERAMIC CHIP	0.1μF		25V
						<p>C0049 1-128-945-31 ELECT 1000μF 20% 10V</p> <p>C0050 1-128-949-31 ELECT 470μF 20% 16V</p> <p>C0051 1-115-416-11 CERAMIC CHIP 0.001μF 5% 25V</p> <p>C0052 1-115-416-11 CERAMIC CHIP 0.001μF 5% 25V</p>					



REF.NO.	PART NO.	DESCRIPTION	VALUES			REF.NO.	PART NO.	DESCRIPTION	VALUES		
C0308	1-126-960-11	ELECT	1 $\mu$ F	20%	50V	C0409	1-125-891-11	CERAMIC CHIP	0.47 $\mu$ F	10%	10V
C0309	1-126-960-11	ELECT	1 $\mu$ F	20%	50V	C0410	1-126-933-11	ELECT	100 $\mu$ F	20%	16V
C0310	1-127-715-91	CERAMIC CHIP	0.22 $\mu$ F	10%	16V	C0411	1-164-156-11	CERAMIC CHIP	0.1 $\mu$ F		25V
C0311	1-162-970-11	CERAMIC CHIP	0.01 $\mu$ F	10%	25V	C0412	1-162-964-11	CERAMIC CHIP	0.001 $\mu$ F	10%	50V
C0312	1-162-970-11	CERAMIC CHIP	0.01 $\mu$ F	10%	25V	C0413	1-126-933-11	ELECT	100 $\mu$ F	20%	16V
C0313	1-162-968-11	CERAMIC CHIP	0.0047 $\mu$ F	10%	50V	C0414	1-162-968-11	CERAMIC CHIP	0.0047 $\mu$ F	10%	50V
C0314	1-164-227-11	CERAMIC CHIP	0.022 $\mu$ F	10%	25V	C0415	1-162-970-11	CERAMIC CHIP	0.01 $\mu$ F	10%	25V
C0315	1-162-968-11	CERAMIC CHIP	0.0047 $\mu$ F	10%	50V	C0416	1-126-935-11	ELECT	470 $\mu$ F	20%	16V
C0317	1-136-169-00	FILM	0.22 $\mu$ F	5%	50V	C0417	1-107-826-11	CERAMIC CHIP	0.1 $\mu$ F	10%	16V
C0318	1-127-715-91	CERAMIC CHIP	0.22 $\mu$ F	10%	16V	C0418	1-164-156-11	CERAMIC CHIP	0.1 $\mu$ F		25V
C0319	1-162-968-11	CERAMIC CHIP	0.0047 $\mu$ F	10%	50V	C0419	1-126-933-11	ELECT	100 $\mu$ F	20%	16V
C0320	1-130-495-00	MYLAR	0.1 $\mu$ F	5%	50V	C0420	1-107-826-11	CERAMIC CHIP	0.1 $\mu$ F	10%	16V
C0321	1-130-495-00	MYLAR	0.1 $\mu$ F	5%	50V	C0421	1-107-826-11	CERAMIC CHIP	0.1 $\mu$ F	10%	16V
C0322	1-136-169-00	FILM	0.22 $\mu$ F	5%	50V	C0422	1-162-970-11	CERAMIC CHIP	0.01 $\mu$ F	10%	25V
C0323	1-162-967-11	CERAMIC CHIP	0.0033 $\mu$ F	10%	50V	C0423	1-126-962-11	ELECT	3.3 $\mu$ F	20%	50V
C0324	1-162-967-11	CERAMIC CHIP	0.0033 $\mu$ F	10%	50V	C0424	1-125-891-11	CERAMIC CHIP	0.47 $\mu$ F	10%	10V
C0325	1-164-677-11	CERAMIC CHIP	0.033 $\mu$ F	10%	16V	C0425	1-162-923-11	CERAMIC CHIP	47pF	5%	50V
C0326	1-164-677-11	CERAMIC CHIP	0.033 $\mu$ F	10%	16V	C0426	1-125-891-11	CERAMIC CHIP	0.47 $\mu$ F	10%	10V
C0327	1-162-962-11	CERAMIC CHIP	470pF	10%	50V	C0427	1-107-826-11	CERAMIC CHIP	0.1 $\mu$ F	10%	16V
C0328	1-162-962-11	CERAMIC CHIP	470pF	10%	50V	C0428	1-107-826-11	CERAMIC CHIP	0.1 $\mu$ F	10%	16V
C0329	1-165-176-11	CERAMIC CHIP	0.047 $\mu$ F	10%	16V	C0429	1-107-826-11	CERAMIC CHIP	0.1 $\mu$ F	10%	16V
C0330	1-165-176-11	CERAMIC CHIP	0.047 $\mu$ F	10%	16V	C0430	1-107-826-11	CERAMIC CHIP	0.1 $\mu$ F	10%	16V
C0332	1-128-934-91	CERAMIC CHIP	0.33 $\mu$ F	20%	10V	C0431	1-107-826-11	CERAMIC CHIP	0.1 $\mu$ F	10%	16V
C0333	1-165-176-11	CERAMIC CHIP	0.047 $\mu$ F	10%	16V	C0432	1-164-156-11	CERAMIC CHIP	0.1 $\mu$ F		25V
C0334	1-126-960-11	ELECT	1 $\mu$ F	20%	50V	C0433	1-107-826-11	CERAMIC CHIP	0.1 $\mu$ F	10%	16V
C0335	1-125-889-91	CERAMIC CHIP	2.2 $\mu$ F	10%	10V	C0434	1-107-826-11	CERAMIC CHIP	0.1 $\mu$ F	10%	16V
C0336	1-165-908-11	CERAMIC CHIP	1 $\mu$ F	10%	10V	C0435	1-107-826-11	CERAMIC CHIP	0.1 $\mu$ F	10%	16V
C0337	1-125-889-91	CERAMIC CHIP	2.2 $\mu$ F	10%	10V	C0436	1-126-933-11	ELECT	100 $\mu$ F	20%	16V
C0338	1-165-908-11	CERAMIC CHIP	1 $\mu$ F	10%	10V	C0437	1-126-963-11	ELECT	4.7 $\mu$ F	20%	50V
C0339	1-126-768-11	ELECT	2200 $\mu$ F	20%	16V	C0438	1-164-156-11	CERAMIC CHIP	0.1 $\mu$ F		25V
C0340	1-165-908-11	CERAMIC CHIP	1 $\mu$ F	10%	10V	C0439	1-164-156-11	CERAMIC CHIP	0.1 $\mu$ F		25V
C0341	1-165-908-11	CERAMIC CHIP	1 $\mu$ F	10%	10V	C0440	1-107-826-11	CERAMIC CHIP	0.1 $\mu$ F	10%	16V
C0342	1-165-908-11	CERAMIC CHIP	1 $\mu$ F	10%	10V	C0441	1-126-933-11	ELECT	100 $\mu$ F	20%	16V
C0343	1-126-933-11	ELECT	100 $\mu$ F	20%	16V	C0442	1-126-933-11	ELECT	100 $\mu$ F	20%	16V
C0344	1-165-908-11	CERAMIC CHIP	1 $\mu$ F	10%	10V	C0444	1-126-933-11	ELECT	100 $\mu$ F	20%	16V
C0345	1-164-156-11	CERAMIC CHIP	0.1 $\mu$ F		25V	C0445	1-127-715-91	CERAMIC CHIP	0.22 $\mu$ F	10%	16V
C0400	1-107-826-11	CERAMIC CHIP	0.1 $\mu$ F	10%	16V	C0446	1-164-156-11	CERAMIC CHIP	0.1 $\mu$ F		25V
C0402	1-107-826-11	CERAMIC CHIP	0.1 $\mu$ F	10%	16V	C0447	1-110-563-11	CERAMIC CHIP	0.068 $\mu$ F	10%	16V
C0403	1-126-933-11	ELECT	100 $\mu$ F	20%	16V	C0448	1-164-156-11	CERAMIC CHIP	0.1 $\mu$ F		25V
C0404	1-164-156-11	CERAMIC CHIP	0.1 $\mu$ F		25V	C0449	1-162-966-11	CERAMIC CHIP	0.0022 $\mu$ F	10%	50V
C0405	1-162-964-11	CERAMIC CHIP	0.001 $\mu$ F	10%	50V	C0450	1-164-156-11	CERAMIC CHIP	0.1 $\mu$ F		25V
C0406	1-162-970-11	CERAMIC CHIP	0.01 $\mu$ F	10%	25V	C0451	1-126-933-11	ELECT	100 $\mu$ F	20%	16V
C0407	1-127-715-91	CERAMIC CHIP	0.22 $\mu$ F	10%	16V	C0452	1-107-826-11	CERAMIC CHIP	0.1 $\mu$ F	10%	16V
C0408	1-164-156-11	CERAMIC CHIP	0.1 $\mu$ F		25V	C0453	1-126-933-11	ELECT	100 $\mu$ F	20%	16V



REF.NO.	PART NO.	DESCRIPTION	VALUES	REF.NO.	PART NO.	DESCRIPTION	VALUES
C0454	1-126-963-11	ELECT	4.7μF 20% 50V				
C0461	1-165-733-31	ELECT	100μF 20% 25V				
C0462	1-126-933-11	ELECT	100μF 20% 16V				
C0463	1-162-970-11	CERAMIC CHIP	0.01μF 10% 25V				
C0464	1-162-970-11	CERAMIC CHIP	0.01μF 10% 25V				
C0465	1-126-767-11	ELECT	1000μF 20% 16V				
C0467	1-162-971-11	CERAMIC CHIP	0.001μF 10% 50V				
<b>CONNECTOR</b>				<b>FERRITE BEAD</b>			
* CN0001	1-793-498-11	CONNECTOR, BOARD TO BOARD	50P	FB0001	1-216-864-11	SHORT CHIP	
* CN0002	1-793-498-11	CONNECTOR, BOARD TO BOARD	50P	FB0003	1-216-864-11	SHORT CHIP	
* CN0004	1-764-333-11	PIN, CONNECTOR(PCB)(V TYPE)	10P	FB0004	1-216-864-11	SHORT CHIP	
* CN0007	1-564-515-11	PLUG, CONNECTOR	12P	FB0005	1-216-864-11	SHORT CHIP	
* CN0008	1-564-507-11	PLUG, CONNECTOR	4P	FB0006	1-216-864-11	SHORT CHIP	
* CN0009	1-564-508-11	PLUG, CONNECTOR	5P	<b>IC</b>			
* CN0010	1-564-508-11	PLUG, CONNECTOR	5P	IC0001	6-803-615-01	IC	M306V7MG-067FP
* CN0012	1-564-509-11	PLUG, CONNECTOR	6P	IC0002	6-803-362-01	IC	M306VSMG-530FP
* CN0013	1-564-506-11	PLUG, CONNECTOR	3P	IC0003	6-801-375-01	IC	PST9129NL
* CN0401	1-764-334-11	PIN, CONNECTOR(PCB)(V TYPE)	11P	IC0004	6-704-573-01	IC	M24C32-WMN6T(B)
* CN0402	1-564-506-11	PLUG, CONNECTOR	3P	IC0005	6-704-573-01	IC	M24C32-WMN6T(B)
* CN0403	1-564-506-11	PLUG, CONNECTOR	3P	IC0006	8-759-641-26	IC	NJM2391DL1-33(TE1)
* CN0404	1-564-506-11	PLUG, CONNECTOR	3P	IC0007	8-759-488-29	IC	TC7W66FU(TE12R)
<b>DIODE</b>				IC0302	6-704-236-01	IC	NJW1148
D0001	8-719-083-57	DIODE	UDZSTE-173.6B	IC0401	8-752-102-68	IC	CXA2170Q
D0002	8-719-066-11	DIODE	1PS184-115	IC0403	8-759-642-22	IC	UPC29M05T-E2
D0003	8-719-066-11	DIODE	1PS184-115	<b>CHIP CONDUCTOR</b>			
D0004	8-719-081-97	DIODE	MMDL914T1	JR1001	1-216-864-11	SHORT CHIP	
D0005	8-719-081-97	DIODE	MMDL914T1	JR1002	1-216-864-11	SHORT CHIP	
D0007	8-719-066-11	DIODE	1PS184-115	JR1003	1-216-864-11	SHORT CHIP	
D0008	8-719-081-97	DIODE	MMDL914T1	JR1004	1-216-864-11	SHORT CHIP	
D0009	8-719-081-97	DIODE	MMDL914T1	JR1005	1-216-864-11	SHORT CHIP	
D0010	8-719-081-97	DIODE	MMDL914T1	JR1006	1-216-864-11	SHORT CHIP	
D0012	8-719-081-97	DIODE	MMDL914T1	JR1007	1-216-864-11	SHORT CHIP	
D0013	8-719-081-97	DIODE	MMDL914T1	JR1008	1-216-864-11	SHORT CHIP	
D0014	8-719-066-11	DIODE	1PS184-115	JR1009	1-216-864-11	SHORT CHIP	
D0403	8-719-081-97	DIODE	MMDL914T1	JR1010	1-216-864-11	SHORT CHIP	
D0404	8-719-036-94	DIODE	RD5.6SB-T1	JR1011	1-216-864-11	SHORT CHIP	
D0405	8-719-977-28	DIODE	DTZ10B	JR1012	1-216-864-11	SHORT CHIP	
D0406	8-719-081-97	DIODE	MMDL914T1	JR1013	1-216-864-11	SHORT CHIP	
D0501	8-719-066-11	DIODE	1PS184-115	JR1014	1-216-864-11	SHORT CHIP	
D0502	8-719-977-28	DIODE	DTZ10B	JR1015	1-216-864-11	SHORT CHIP	
				JR1016	1-216-864-11	SHORT CHIP	
				JR1017	1-216-864-11	SHORT CHIP	
				JR1018	1-216-864-11	SHORT CHIP	
				JR1019	1-216-864-11	SHORT CHIP	
				JR1020	1-216-864-11	SHORT CHIP	
				JR1021	1-216-864-11	SHORT CHIP	
				<b>COIL</b>			
				L0001	1-400-397-11	INDUCTOR	10μH
				L0002	1-400-397-11	INDUCTOR	10μH



REF.NO.	PART NO.	DESCRIPTION	VALUES	REF.NO.	PART NO.	DESCRIPTION	VALUES
L0004	1-400-397-11	INDUCTOR	10μH	Q0405	8-729-010-25	TRANSISTOR	MSD601-RT1
L0005	1-400-397-11	INDUCTOR	10μH	Q0406	8-729-010-25	TRANSISTOR	MSD601-RT1
L0006	1-412-943-11	INDUCTOR	2.2μH	Q0407	8-729-010-25	TRANSISTOR	MSD601-RT1
L0007	1-216-864-11	SHORT CHIP		Q0408	8-729-010-25	TRANSISTOR	MSD601-RT1
L0401	1-400-397-11	INDUCTOR	10μH	Q0409	8-729-122-63	TRANSISTOR	2SA1226-E4
L0402	1-400-397-11	INDUCTOR	10μH	Q0410	8-729-010-05	TRANSISTOR	MSB709-RT1
L0403	1-400-397-11	INDUCTOR	10μH	Q0411	8-729-010-05	TRANSISTOR	MSB709-RT1
L0404	1-469-559-21	INDUCTOR	47μH	Q0412	8-729-010-25	TRANSISTOR	MSD601-RT1
L0405	1-400-397-11	INDUCTOR	10μH	Q0413	8-729-010-25	TRANSISTOR	MSD601-RT1
L0406	1-400-397-11	INDUCTOR	10μH	Q0414	8-729-010-25	TRANSISTOR	MSD601-RT1
L0407	1-400-397-11	INDUCTOR	10μH	Q0415	8-729-010-05	TRANSISTOR	MSB709-RT1
L0408	1-400-397-11	INDUCTOR	10μH	Q0416	8-729-010-05	TRANSISTOR	MSB709-RT1
		<b>TRANSISTOR</b>		Q0417	8-729-010-05	TRANSISTOR	MSB709-RT1
Q0001	8-729-010-25	TRANSISTOR	MSD601-RT1	Q0418	8-729-010-25	TRANSISTOR	MSD601-RT1
Q0002	8-729-010-25	TRANSISTOR	MSD601-RT1	Q0419	8-729-122-63	TRANSISTOR	2SA1226-E4
Q0003	8-729-010-25	TRANSISTOR	MSD601-RT1	Q0420	8-729-122-63	TRANSISTOR	2SA1226-E4
Q0004	8-729-010-25	TRANSISTOR	MSD601-RT1	Q0422	8-729-122-63	TRANSISTOR	2SA1226-E4
Q0005	8-729-010-25	TRANSISTOR	MSD601-RT1	Q0427	8-729-028-97	TRANSISTOR	DTC114TUA-T106
Q0006	8-729-010-25	TRANSISTOR	MSD601-RT1	Q0428	8-729-028-97	TRANSISTOR	DTC114TUA-T106
Q0007	8-729-010-25	TRANSISTOR	MSD601-RT1	Q0429	8-729-028-97	TRANSISTOR	DTC114TUA-T106
Q0008	8-729-010-05	TRANSISTOR	MSB709-RT1	Q0430	8-729-029-14	TRANSISTOR	DTC144EUA-T106
Q0009	8-729-010-05	TRANSISTOR	MSB709-RT1	Q0432	8-729-010-25	TRANSISTOR	MSD601-RT1
Q0010	8-729-010-25	TRANSISTOR	MSD601-RT1			<b>RESISTOR</b>	
Q0011	8-729-010-25	TRANSISTOR	MSD601-RT1	R0001	1-216-821-11	METAL CHIP	1K 5% 1/10W
Q0012	8-729-010-25	TRANSISTOR	MSD601-RT1	R0002	1-216-821-11	METAL CHIP	1K 5% 1/10W
Q0013	8-729-010-25	TRANSISTOR	MSD601-RT1	R0004	1-216-809-11	METAL CHIP	100 5% 1/10W
Q0014	8-729-010-25	TRANSISTOR	MSD601-RT1	R0005	1-216-833-11	METAL CHIP	10K 5% 1/10W
Q0015	8-729-010-25	TRANSISTOR	MSD601-RT1	R0006	1-216-809-11	METAL CHIP	100 5% 1/10W
Q0016	8-729-010-25	TRANSISTOR	MSD601-RT1	R0007	1-216-821-11	METAL CHIP	1K 5% 1/10W
Q0017	8-729-010-05	TRANSISTOR	MSB709-RT1	R0008	1-216-829-11	METAL CHIP	4.7K 5% 1/10W
Q0018	8-729-010-25	TRANSISTOR	MSD601-RT1	R0009	1-216-821-11	METAL CHIP	1K 5% 1/10W
Q0020	8-729-010-25	TRANSISTOR	MSD601-RT1	R0010	1-216-857-11	METAL CHIP	1M 5% 1/10W
Q0022	8-729-010-05	TRANSISTOR	MSB709-RT1	R0011	1-216-857-11	METAL CHIP	1M 5% 1/10W
Q0025	8-729-029-14	TRANSISTOR	DTC144EUA-T106	R0012	1-216-829-11	METAL CHIP	4.7K 5% 1/10W
Q0301	8-729-010-05	TRANSISTOR	MSB709-RT1	R0013	1-216-833-11	METAL CHIP	10K 5% 1/10W
Q0302	8-729-010-25	TRANSISTOR	MSD601-RT1	R0014	1-216-821-11	METAL CHIP	1K 5% 1/10W
Q0303	8-729-010-25	TRANSISTOR	MSD601-RT1	R0015	1-216-809-11	METAL CHIP	100 5% 1/10W
Q0304	8-729-010-25	TRANSISTOR	MSD601-RT1	R0016	1-216-809-11	METAL CHIP	100 5% 1/10W
Q0306	8-729-010-25	TRANSISTOR	MSD601-RT1	R0017	1-216-809-11	METAL CHIP	100 5% 1/10W
Q0401	8-729-010-25	TRANSISTOR	MSD601-RT1	R0018	1-216-809-11	METAL CHIP	100 5% 1/10W
Q0402	8-729-010-25	TRANSISTOR	MSD601-RT1	R0019	1-216-833-11	METAL CHIP	10K 5% 1/10W
Q0403	8-729-010-25	TRANSISTOR	MSD601-RT1	R0020	1-216-809-11	METAL CHIP	100 5% 1/10W
Q0404	8-729-010-25	TRANSISTOR	MSD601-RT1	R0021	1-216-809-11	METAL CHIP	100 5% 1/10W



REF.NO.	PART NO.	DESCRIPTION	VALUES			REF.NO.	PART NO.	DESCRIPTION	VALUES		
R0022	1-216-809-11	METAL CHIP	100	5%	1/10W	R0069	1-216-864-11	SHORT CHIP			
R0023	1-216-809-11	METAL CHIP	100	5%	1/10W	R0070	1-216-816-11	METAL CHIP	390	5%	1/10W
R0024	1-216-841-11	METAL CHIP	47K	5%	1/10W	R0071	1-216-833-11	METAL CHIP	10K	5%	1/10W
R0025	1-216-829-11	METAL CHIP	4.7K	5%	1/10W	R0072	1-216-809-11	METAL CHIP	100	5%	1/10W
R0026	1-216-809-11	METAL CHIP	100	5%	1/10W	R0073	1-216-809-11	METAL CHIP	100	5%	1/10W
R0027	1-216-821-11	METAL CHIP	1K	5%	1/10W	R0074	1-216-809-11	METAL CHIP	100	5%	1/10W
R0028	1-216-833-11	METAL CHIP	10K	5%	1/10W	R0075	1-216-809-11	METAL CHIP	100	5%	1/10W
R0029	1-216-809-11	METAL CHIP	100	5%	1/10W	R0076	1-216-864-11	SHORT CHIP			
R0030	1-216-813-11	METAL CHIP	220	5%	1/10W	R0077	1-216-837-11	METAL CHIP	22K	5%	1/10W
R0031	1-216-809-11	METAL CHIP	100	5%	1/10W	R0078	1-216-816-11	METAL CHIP	390	5%	1/10W
R0032	1-216-809-11	METAL CHIP	100	5%	1/10W	R0079	1-216-839-11	METAL CHIP	33K	5%	1/10W
R0034	1-216-809-11	METAL CHIP	100	5%	1/10W	R0080	1-216-833-11	METAL CHIP	10K	5%	1/10W
R0035	1-216-817-11	METAL CHIP	470	5%	1/10W	R0081	1-216-841-11	METAL CHIP	47K	5%	1/10W
R0036	1-216-797-11	METAL CHIP	10	5%	1/10W	R0082	1-216-841-11	METAL CHIP	47K	5%	1/10W
R0039	1-216-809-11	METAL CHIP	100	5%	1/10W	R0083	1-216-833-11	METAL CHIP	10K	5%	1/10W
R0040	1-216-809-11	METAL CHIP	100	5%	1/10W	R0084	1-216-821-11	METAL CHIP	1K	5%	1/10W
R0041	1-216-809-11	METAL CHIP	100	5%	1/10W	R0085	1-216-829-11	METAL CHIP	4.7K	5%	1/10W
R0042	1-216-820-11	METAL CHIP	820	5%	1/10W	R0086	1-216-821-11	METAL CHIP	1K	5%	1/10W
R0044	1-216-797-11	METAL CHIP	10	5%	1/10W	R0087	1-216-839-11	METAL CHIP	33K	5%	1/10W
R0045	1-216-809-11	METAL CHIP	100	5%	1/10W	R0088	1-216-833-11	METAL CHIP	10K	5%	1/10W
R0046	1-216-809-11	METAL CHIP	100	5%	1/10W	R0089	1-216-833-11	METAL CHIP	10K	5%	1/10W
R0047	1-216-809-11	METAL CHIP	100	5%	1/10W	R0091	1-216-833-11	METAL CHIP	10K	5%	1/10W
R0048	1-216-833-11	METAL CHIP	10K	5%	1/10W	R0092	1-216-833-11	METAL CHIP	10K	5%	1/10W
R0049	1-216-833-11	METAL CHIP	10K	5%	1/10W	R0093	1-216-837-11	METAL CHIP	22K	5%	1/10W
R0050	1-216-833-11	METAL CHIP	10K	5%	1/10W	R0094	1-216-833-11	METAL CHIP	10K	5%	1/10W
R0051	1-216-833-11	METAL CHIP	10K	5%	1/10W	R0095	1-216-833-11	METAL CHIP	10K	5%	1/10W
R0052	1-216-833-11	METAL CHIP	10K	5%	1/10W	R0096	1-216-833-11	METAL CHIP	10K	5%	1/10W
R0053	1-216-833-11	METAL CHIP	10K	5%	1/10W	R0097	1-211-990-11	METAL CHIP	75	0.50%	1/10W
R0054	1-216-845-11	METAL CHIP	100K	5%	1/10W	R0098	1-216-809-11	METAL CHIP	100	5%	1/10W
R0055	1-216-833-11	METAL CHIP	10K	5%	1/10W	R0099	1-216-809-11	METAL CHIP	100	5%	1/10W
R0056	1-216-841-11	METAL CHIP	47K	5%	1/10W	R0100	1-216-809-11	METAL CHIP	100	5%	1/10W
R0057	1-216-809-11	METAL CHIP	100	5%	1/10W	R0101	1-216-833-11	METAL CHIP	10K	5%	1/10W
R0058	1-216-809-11	METAL CHIP	100	5%	1/10W	R0102	1-216-821-11	METAL CHIP	1K	5%	1/10W
R0059	1-216-809-11	METAL CHIP	100	5%	1/10W	R0103	1-216-809-11	METAL CHIP	100	5%	1/10W
R0060	1-216-805-11	METAL CHIP	47	5%	1/10W	R0104	1-216-833-11	METAL CHIP	10K	5%	1/10W
R0061	1-216-833-11	METAL CHIP	10K	5%	1/10W	R0105	1-216-825-11	METAL CHIP	2.2K	5%	1/10W
R0062	1-216-805-11	METAL CHIP	47	5%	1/10W	R0107	1-216-833-11	METAL CHIP	10K	5%	1/10W
R0063	1-216-821-11	METAL CHIP	1K	5%	1/10W	R0109	1-216-841-11	METAL CHIP	47K	5%	1/10W
R0064	1-216-864-11	SHORT CHIP				R0110	1-216-817-11	METAL CHIP	470	5%	1/10W
R0065	1-216-816-11	METAL CHIP	390	5%	1/10W	R0111	1-216-825-11	METAL CHIP	2.2K	5%	1/10W
R0066	1-216-841-11	METAL CHIP	47K	5%	1/10W	R0112	1-216-829-11	METAL CHIP	4.7K	5%	1/10W
R0067	1-216-809-11	METAL CHIP	100	5%	1/10W	R0113	1-216-821-11	METAL CHIP	1K	5%	1/10W
R0068	1-216-833-11	METAL CHIP	10K	5%	1/10W	R0114	1-216-817-11	METAL CHIP	470	5%	1/10W
						R0115	1-216-809-11	METAL CHIP	100	5%	1/10W



REF.NO.	PART NO.	DESCRIPTION	VALUES			REF.NO.	PART NO.	DESCRIPTION	VALUES		
R0116	1-216-809-11	METAL CHIP	100	5%	1/10W	R0327	1-216-821-11	METAL CHIP	1K	5%	1/10W
R0118	1-216-833-11	METAL CHIP	10K	5%	1/10W	R0328	1-218-873-11	METAL CHIP	12K	0.50%	1/10W
R0119	1-216-829-11	METAL CHIP	4.7K	5%	1/10W	R0329	1-218-871-11	METAL CHIP	10K	0.50%	1/10W
R0120	1-216-829-11	METAL CHIP	4.7K	5%	1/10W	R0330	1-218-873-11	METAL CHIP	12K	0.50%	1/10W
R0121	1-216-833-11	METAL CHIP	10K	5%	1/10W	R0331	1-216-821-11	METAL CHIP	1K	5%	1/10W
R0122	1-216-833-11	METAL CHIP	10K	5%	1/10W	R0334	1-216-829-11	METAL CHIP	4.7K	5%	1/10W
R0123	1-216-841-11	METAL CHIP	47K	5%	1/10W	R0335	1-216-829-11	METAL CHIP	4.7K	5%	1/10W
R0124	1-216-833-11	METAL CHIP	10K	5%	1/10W	R0336	1-216-864-11	SHORT CHIP			
R0125	1-216-809-11	METAL CHIP	100	5%	1/10W	R0338	1-216-864-11	SHORT CHIP			
R0126	1-216-809-11	METAL CHIP	100	5%	1/10W	R0340	1-216-864-11	SHORT CHIP			
R0129	1-216-833-11	METAL CHIP	10K	5%	1/10W	R0350	1-216-864-11	SHORT CHIP			
R0131	1-216-809-11	METAL CHIP	100	5%	1/10W	R0359	1-216-864-11	SHORT CHIP			
R0132	1-216-809-11	METAL CHIP	100	5%	1/10W	R0360	1-216-864-11	SHORT CHIP			
R0133	1-216-809-11	METAL CHIP	100	5%	1/10W	R0401	1-216-809-11	METAL CHIP	100	5%	1/10W
R0134	1-216-833-11	METAL CHIP	10K	5%	1/10W	R0402	1-216-809-11	METAL CHIP	100	5%	1/10W
R0135	1-216-809-11	METAL CHIP	100	5%	1/10W	R0403	1-216-809-11	METAL CHIP	100	5%	1/10W
R0136	1-216-809-11	METAL CHIP	100	5%	1/10W	R0406	1-216-815-11	METAL CHIP	330	5%	1/10W
R0137	1-216-833-11	METAL CHIP	10K	5%	1/10W	R0407	1-216-809-11	METAL CHIP	100	5%	1/10W
R0138	1-216-809-11	METAL CHIP	100	5%	1/10W	R0410	1-218-871-11	METAL CHIP	10K	0.50%	1/10W
R0139	1-216-829-11	METAL CHIP	4.7K	5%	1/10W	R0411	1-218-871-11	METAL CHIP	10K	0.50%	1/10W
R0140	1-216-809-11	METAL CHIP	100	5%	1/10W	R0412	1-218-871-11	METAL CHIP	10K	0.50%	1/10W
R0143	1-216-809-11	METAL CHIP	100	5%	1/10W	R0413	1-216-841-11	METAL CHIP	47K	5%	1/10W
R0144	1-216-809-11	METAL CHIP	100	5%	1/10W	R0414	1-216-841-11	METAL CHIP	47K	5%	1/10W
R0145	1-216-833-11	METAL CHIP	10K	5%	1/10W	R0416	1-216-809-11	METAL CHIP	100	5%	1/10W
R0148	1-216-809-11	METAL CHIP	100	5%	1/10W	R0417	1-218-871-11	METAL CHIP	10K	0.50%	1/10W
R0149	1-216-809-11	METAL CHIP	100	5%	1/10W	R0418	1-216-845-11	METAL CHIP	100K	5%	1/10W
R0150	1-216-829-11	METAL CHIP	4.7K	5%	1/10W	R0421	1-216-832-11	METAL CHIP	8.2K	5%	1/10W
R0153	1-216-829-11	METAL CHIP	4.7K	5%	1/10W	R0422	1-216-809-11	METAL CHIP	100	5%	1/10W
R0307	1-216-821-11	METAL CHIP	1K	5%	1/10W	R0423	1-216-853-11	METAL CHIP	470K	5%	1/10W
R0308	1-216-841-11	METAL CHIP	47K	5%	1/10W	R0424	1-216-809-11	METAL CHIP	100	5%	1/10W
R0309	1-216-821-11	METAL CHIP	1K	5%	1/10W	R0425	1-216-809-11	METAL CHIP	100	5%	1/10W
R0310	1-216-821-11	METAL CHIP	1K	5%	1/10W	R0426	1-216-809-11	METAL CHIP	100	5%	1/10W
R0311	1-216-809-11	METAL CHIP	100	5%	1/10W	R0427	1-216-809-11	METAL CHIP	100	5%	1/10W
R0312	1-216-853-11	METAL CHIP	470K	5%	1/10W	R0428	1-216-818-11	METAL CHIP	560	5%	1/10W
R0313	1-216-809-11	METAL CHIP	100	5%	1/10W	R0430	1-216-864-11	SHORT CHIP			
R0314	1-216-853-11	METAL CHIP	470K	5%	1/10W	R0431	1-216-825-11	METAL CHIP	2.2K	5%	1/10W
R0315	1-216-821-11	METAL CHIP	1K	5%	1/10W	R0432	1-216-821-11	METAL CHIP	1K	5%	1/10W
R0316	1-216-821-11	METAL CHIP	1K	5%	1/10W	R0433	1-216-809-11	METAL CHIP	100	5%	1/10W
R0318	1-216-833-11	METAL CHIP	10K	5%	1/10W	R0434	1-216-809-11	METAL CHIP	100	5%	1/10W
R0320	1-216-809-11	METAL CHIP	100	5%	1/10W	R0435	1-216-821-11	METAL CHIP	1K	5%	1/10W
R0322	1-216-833-11	METAL CHIP	10K	5%	1/10W	R0436	1-216-821-11	METAL CHIP	1K	5%	1/10W
R0324	1-216-809-11	METAL CHIP	100	5%	1/10W	R0437	1-216-826-11	METAL CHIP	2.7K	5%	1/10W
R0325	1-216-853-11	METAL CHIP	470K	5%	1/10W	R0438	1-216-809-11	METAL CHIP	100	5%	1/10W
R0326	1-216-853-11	METAL CHIP	470K	5%	1/10W	R0439	1-216-821-11	METAL CHIP	1K	5%	1/10W





REF.NO.	PART NO.	DESCRIPTION	VALUES			REF.NO.	PART NO.	DESCRIPTION	VALUES		
R0441	1-216-809-11	METAL CHIP	100	5%	1/10W	R0497	1-216-825-11	METAL CHIP	2.2K	5%	1/10W
R0442	1-216-834-11	METAL CHIP	12K	5%	1/10W	R0498	1-216-825-11	METAL CHIP	2.2K	5%	1/10W
R0443	1-218-863-11	METAL CHIP	4.7K	0.50%	1/10W	R0499	1-216-825-11	METAL CHIP	2.2K	5%	1/10W
R0444	1-216-809-11	METAL CHIP	100	5%	1/10W	R0500	1-216-825-11	METAL CHIP	2.2K	5%	1/10W
R0445	1-216-809-11	METAL CHIP	100	5%	1/10W	R0501	1-216-825-11	METAL CHIP	2.2K	5%	1/10W
R0446	1-216-809-11	METAL CHIP	100	5%	1/10W	R0502	1-216-825-11	METAL CHIP	2.2K	5%	1/10W
R0447	1-216-825-11	METAL CHIP	2.2K	5%	1/10W	R0503	1-216-825-11	METAL CHIP	2.2K	5%	1/10W
R0448	1-216-829-11	METAL CHIP	4.7K	5%	1/10W	R0504	1-216-825-11	METAL CHIP	2.2K	5%	1/10W
R0449	1-216-809-11	METAL CHIP	100	5%	1/10W	R0505	1-216-825-11	METAL CHIP	2.2K	5%	1/10W
R0451	1-216-823-11	METAL CHIP	1.5K	5%	1/10W	R0506	1-216-825-11	METAL CHIP	2.2K	5%	1/10W
R0453	1-216-863-11	METAL CHIP	3.3M	5%	1/10W	R0507	1-216-809-11	METAL CHIP	100	5%	1/10W
R0456	1-216-809-11	METAL CHIP	100	5%	1/10W	R0517	1-216-829-11	METAL CHIP	4.7K	5%	1/10W
R0457	1-216-809-11	METAL CHIP	100	5%	1/10W	R0518	1-216-825-11	METAL CHIP	2.2K	5%	1/10W
R0458	1-216-809-11	METAL CHIP	100	5%	1/10W	R0522	1-216-821-11	METAL CHIP	1K	5%	1/10W
R0459	1-216-827-11	METAL CHIP	3.3K	5%	1/10W	R0523	1-216-821-11	METAL CHIP	1K	5%	1/10W
R0460	1-216-815-11	METAL CHIP	330	5%	1/10W	R0524	1-216-864-11	SHORT CHIP			
R0462	1-216-829-11	METAL CHIP	4.7K	5%	1/10W	R0551	1-216-804-11	METAL CHIP	39	5%	1/10W
R0463	1-216-829-11	METAL CHIP	4.7K	5%	1/10W	R0552	1-216-804-11	METAL CHIP	39	5%	1/10W
R0464	1-216-829-11	METAL CHIP	4.7K	5%	1/10W	R0553	1-216-804-11	METAL CHIP	39	5%	1/10W
R0466	1-216-825-11	METAL CHIP	2.2K	5%	1/10W	R0555	1-216-803-11	METAL CHIP	33	5%	1/10W
R0468	1-216-825-11	METAL CHIP	2.2K	5%	1/10W	R0556	1-216-803-11	METAL CHIP	33	5%	1/10W
R0469	1-216-825-11	METAL CHIP	2.2K	5%	1/10W	R0557	1-216-803-11	METAL CHIP	33	5%	1/10W
R0470	1-216-829-11	METAL CHIP	4.7K	5%	1/10W	R0559	1-216-813-11	METAL CHIP	220	5%	1/10W
R0471	1-216-825-11	METAL CHIP	2.2K	5%	1/10W	R0560	1-216-825-11	METAL CHIP	2.2K	5%	1/10W
R0472	1-216-825-11	METAL CHIP	2.2K	5%	1/10W	R0561	1-216-825-11	METAL CHIP	2.2K	5%	1/10W
R0473	1-216-825-11	METAL CHIP	2.2K	5%	1/10W	R0562	1-216-825-11	METAL CHIP	2.2K	5%	1/10W
R0474	1-216-825-11	METAL CHIP	2.2K	5%	1/10W	R0563	1-216-805-11	METAL CHIP	47	5%	1/10W
R0475	1-216-821-11	METAL CHIP	1K	5%	1/10W						
R0477	1-216-815-11	METAL CHIP	330	5%	1/10W						
R0478	1-218-871-11	METAL CHIP	10K	0.50%	1/10W						
R0479	1-216-825-11	METAL CHIP	2.2K	5%	1/10W						
R0480	1-216-809-11	METAL CHIP	100	5%	1/10W						
R0481	1-216-825-11	METAL CHIP	2.2K	5%	1/10W						
R0482	1-216-833-11	METAL CHIP	10K	5%	1/10W						
R0484	1-216-809-11	METAL CHIP	100	5%	1/10W						
R0485	1-216-825-11	METAL CHIP	2.2K	5%	1/10W						
R0486	1-216-825-11	METAL CHIP	2.2K	5%	1/10W						
R0488	1-216-825-11	METAL CHIP	2.2K	5%	1/10W						
R0489	1-218-875-11	METAL CHIP	15K	0.50%	1/10W						
R0490	1-216-825-11	METAL CHIP	2.2K	5%	1/10W						
R0492	1-216-825-11	METAL CHIP	2.2K	5%	1/10W						
R0493	1-216-864-11	SHORT CHIP									
R0494	1-216-864-11	SHORT CHIP									
R0496	1-216-809-11	METAL CHIP	100	5%	1/10W						

**CRYSTAL**

X0001	1-767-686-21	VIBRATOR, CRYSTAL
X0002	1-781-589-21	VIBRATOR, CRYSTAL
X0401	1-760-895-21	VIBRATOR, CERAMIC



- \* **A-1302-158-A A BOARD, COMPLETE**  
 4-382-854-01 SCREW (M3X8), P, SW (+)  
 4-382-854-11 SCREW (M3X10), P, SW (+)



**CAPACITOR**

C2000	1-136-177-00	FILM	1μF	5%	50V
C2001	1-162-964-11	CERAMIC CHIP	0.001μF	10%	50V
C2002	1-162-964-11	CERAMIC CHIP	0.001μF	10%	50V
C2005	1-164-161-11	CERAMIC CHIP	0.0022μF	10%	50V
C2006	1-100-158-91	CERAMIC CHIP	1000pF	5%	1000V

NOTE: The components identified by shading and  mark are critical for safety. Replace only with part number specified.

NOTE: Les composants identifiés par un trame et une  sont critiques pour la sécurité. Ne les remplacer que par une pièce portant le numéro spécifique.





REF.NO.	PART NO.	DESCRIPTION	VALUES			REF.NO.	PART NO.	DESCRIPTION	VALUES		
C2007	1-137-194-81	FILM	0.47μF	5%	50V	C2064	1-126-041-11	ELECT	2200μF	20%	35V
C2008	1-164-677-11	CERAMIC CHIP	0.033μF	10%	16V	C2065	1-126-041-11	ELECT	2200μF	20%	35V
C2011	1-164-315-11	CERAMIC CHIP	470pF	5%	50V	C2066	1-162-970-11	CERAMIC CHIP	0.01μF	10%	25V
C2013	1-162-966-11	CERAMIC CHIP	0.0022μF	10%	50V	C2067	1-100-158-91	CERAMIC CHIP	1000pF	5%	100V
C2014	1-109-953-11	ELECT	2.2μF	20%	50V	C2071	1-162-966-11	CERAMIC CHIP	0.0022μF	10%	50V
C2015	1-162-975-11	CERAMIC CHIP	24pF	5%	50V	C2072	1-162-966-11	CERAMIC CHIP	0.0022μF	10%	50V
C2016	1-164-315-11	CERAMIC CHIP	470pF	5%	50V	C2075	1-125-837-91	CERAMIC CHIP	1μF	10%	6.3V
C2018	1-162-966-11	CERAMIC CHIP	0.0022μF	10%	50V	C2076	1-125-837-91	CERAMIC CHIP	1μF	10%	6.3V
C2019	1-126-964-11	ELECT	10μF	20%	50V	C2077	1-125-837-91	CERAMIC CHIP	1μF	10%	6.3V
C2020	1-162-964-11	CERAMIC CHIP	0.001μF	10%	50V	C2078	1-165-176-11	CERAMIC CHIP	0.047μF	10%	16V
C2021	1-162-959-11	CERAMIC CHIP	330pF	5%	50V	C2079	1-164-230-11	CERAMIC CHIP	220pF	5%	50V
C2022	1-164-156-11	CERAMIC CHIP	0.1μF		25V	C2080	1-162-962-11	CERAMIC CHIP	470pF	10%	50V
C2023	1-162-966-11	CERAMIC CHIP	0.0022μF	10%	50V	C2081	1-162-962-11	CERAMIC CHIP	470pF	10%	50V
C2024	1-107-704-51	ELECT	470μF	20%	25V	C2082	1-126-933-11	ELECT	100μF	20%	16V
C2025	1-137-194-81	FILM	0.47μF	5%	50V	C2083	1-126-947-11	ELECT	47μF	20%	35V
C2027	1-162-966-11	CERAMIC CHIP	0.0022μF	10%	50V	C2084	1-216-864-11	SHORT CHIP			
C2028	1-162-966-11	CERAMIC CHIP	0.0022μF	10%	50V	C2085	1-162-970-11	CERAMIC CHIP	0.01μF	10%	25V
C2029	1-126-933-11	ELECT	100μF	20%	16V	C2086	1-162-962-11	CERAMIC CHIP	470pF	10%	50V
C2030	1-126-933-11	ELECT	100μF	20%	16V	C2088	1-126-967-11	ELECT	47μF	20%	50V
C2031	1-162-959-11	CERAMIC CHIP	330pF	5%	50V	C2090	1-162-962-11	CERAMIC CHIP	470pF	10%	50V
C2033	1-162-966-11	CERAMIC CHIP	0.0022μF	10%	50V	C2091	1-126-964-11	ELECT	10μF	20%	50V
C2034	1-164-156-11	CERAMIC CHIP	0.1μF		25V	C2092	1-126-933-11	ELECT	100μF	20%	16V
C2035	1-125-837-91	CERAMIC CHIP	1μF	10%	6.3V	C2096	1-162-964-11	CERAMIC CHIP	0.001μF	10%	50V
C2036	1-126-933-11	ELECT	100μF	20%	16V	C2097	1-162-964-11	CERAMIC CHIP	0.001μF	10%	50V
C2038	1-162-964-11	CERAMIC CHIP	0.001μF	10%	50V	C2098	1-136-177-00	FILM	1μF	5%	50V
C2039	1-164-315-11	CERAMIC CHIP	470pF	5%	50V	C2100	1-136-177-00	FILM	1μF	5%	50V
C2040	1-126-964-11	ELECT	10μF	20%	50V	 C6001	1-165-530-31	MYLAR	0.47μF	10	0V
C2041	1-164-315-11	CERAMIC CHIP	470pF	5%	50V	 C6002	1-119-894-51	CERAMIC	2200pF	20%	250V
C2042	1-162-964-11	CERAMIC CHIP	0.001μF	10%	50V	 C6003	1-165-530-31	MYLAR	0.47μF	10	0V
C2043	1-100-158-91	CERAMIC CHIP	1000pF	5%	100V	 C6004	1-119-894-51	CERAMIC	2200pF	20%	250V
C2044	1-162-966-11	CERAMIC CHIP	0.0022μF	10%	50V	C6007	1-161-964-91	CERAMIC	0.0047μF		250V
C2047	1-136-177-00	FILM	1μF	5%	50V	C6008	1-161-964-91	CERAMIC	0.0047μF		250V
C2048	1-165-176-11	CERAMIC CHIP	0.047μF	10%	16V	C6011	1-137-750-11	ELECT	1500μF	20%	250V
C2049	1-126-066-11	ELECT	470μF	20%	63V	C6012	1-137-750-11	ELECT	1500μF	20%	250V
C2050	1-164-677-11	CERAMIC CHIP	0.033μF	10%	16V	C6110	1-126-964-11	ELECT	10μF	20%	50V
C2053	1-164-230-11	CERAMIC CHIP	220pF	5%	50V	C6111	1-164-156-11	CERAMIC CHIP	0.1μF		25V
C2054	1-100-158-91	CERAMIC CHIP	1000pF	5%	100V	C6112	1-126-965-91	ELECT	22μF	20%	50V
C2055	1-126-933-11	ELECT	100μF	20%	16V	C6115	1-126-943-11	ELECT	2200μF	20%	25V
C2056	1-126-935-11	ELECT	470μF	20%	16V	C6116	1-128-562-11	ELECT	47μF	20%	100V
C2057	1-164-156-11	CERAMIC CHIP	0.1μF		25V	C6118	1-162-970-11	CERAMIC CHIP	0.01μF	10%	25V
C2058	1-126-964-11	ELECT	10μF	20%	50V	C6119	1-126-960-11	ELECT	1μF	20%	50V
C2061	1-162-966-11	CERAMIC CHIP	0.0022μF	10%	50V	C6120	1-126-968-11	ELECT	100μF	20%	50V
C2062	1-115-339-11	CERAMIC CHIP	0.1μF	10%	50V	C6125	1-162-966-11	CERAMIC CHIP	0.0022μF	10%	50V
C2063	1-115-339-11	CERAMIC CHIP	0.1μF	10%	50V	C6126	1-162-966-11	CERAMIC CHIP	0.0022μF	10%	50V





NOTE: The components identified by shading and  mark are critical for safety. Replace only with part number specified.

NOTE: Les composants identifiés par un trame et une marque  sont critiques pour la sécurité. Ne les remplacer que par une pièce portant le numéro spécifique.





REF.NO.	PART NO.	DESCRIPTION	VALUES	REF.NO.	PART NO.	DESCRIPTION	VALUES	
FB2004	1-469-578-11	FERRITE	1.1μH	JR34	1-216-864-11	SHORT CHIP		
FB2005	1-469-578-11	FERRITE	1.1μH	JR35	1-216-864-11	SHORT CHIP		
FB6200	1-412-911-11	FERRITE	0μH	JR36	1-216-864-11	SHORT CHIP		
FB6201	1-412-911-11	FERRITE	0μH	JR37	1-216-864-11	SHORT CHIP		
FB6202	1-412-911-11	FERRITE	0μH	JR38	1-216-864-11	SHORT CHIP		
<b>FUSE HOLDER</b>				JR39	1-216-864-11	SHORT CHIP		
	FH6000	1-533-223-11	FUSE HOLDER	0A	0V	JR40	1-216-864-11	SHORT CHIP
	FH6001	1-533-223-11	FUSE HOLDER	0A	0V	JR41	1-216-864-11	SHORT CHIP
<b>IC</b>				JR42	1-216-864-11	SHORT CHIP		
IC2000	6-704-233-01	IC	TDA7490	JR43	1-216-864-11	SHORT CHIP		
IC6100	6-704-655-01	IC	NJU7223F50	JR44	1-216-864-11	SHORT CHIP		
IC6200	6-703-656-01	IC	SI-8090S	JR45	1-216-864-11	SHORT CHIP		
IC6201	8-759-474-09	IC	SI-8050S-LF1101	JR46	1-216-864-11	SHORT CHIP		
IC6202	8-759-659-28	IC	SI-8033S	JR47	1-216-864-11	SHORT CHIP		
IC6203	6-700-813-01	IC	SI-8033JF	JR48	1-216-864-11	SHORT CHIP		
<b>CHIP CONDUCTOR</b>				JR49	1-216-864-11	SHORT CHIP		
JR1	1-216-295-91	SHORT CHIP		JR50	1-216-864-11	SHORT CHIP		
JR2	1-216-295-91	SHORT CHIP		JR51	1-216-864-11	SHORT CHIP		
JR3	1-216-295-91	SHORT CHIP		JR52	1-216-864-11	SHORT CHIP		
JR4	1-216-295-91	SHORT CHIP		JR53	1-216-864-11	SHORT CHIP		
JR5	1-216-295-91	SHORT CHIP		JR54	1-216-864-11	SHORT CHIP		
JR6	1-216-295-91	SHORT CHIP		JR55	1-216-864-11	SHORT CHIP		
JR7	1-216-295-91	SHORT CHIP		JR2003	1-216-864-11	SHORT CHIP		
JR8	1-216-295-91	SHORT CHIP		JR6200	1-216-864-11	SHORT CHIP		
JR9	1-216-295-91	SHORT CHIP		JR6201	1-216-864-11	SHORT CHIP		
JR10	1-216-295-91	SHORT CHIP		JR6202	1-216-864-11	SHORT CHIP		
JR11	1-216-295-91	SHORT CHIP		JR6204	1-216-864-11	SHORT CHIP		
JR13	1-216-295-91	SHORT CHIP		JR6206	1-216-295-91	SHORT CHIP		
JR14	1-216-295-91	SHORT CHIP		JR6207	1-216-864-11	SHORT CHIP		
JR15	1-216-295-91	SHORT CHIP		JR6209	1-216-864-11	SHORT CHIP		
JR16	1-216-295-91	SHORT CHIP		JR6211	1-216-864-11	SHORT CHIP		
JR17	1-216-295-91	SHORT CHIP		JR6213	1-216-864-11	SHORT CHIP		
JR18	1-216-864-11	SHORT CHIP		JR6507	1-216-864-11	SHORT CHIP		
JR19	1-216-864-11	SHORT CHIP		<b>COIL</b>				
JR20	1-216-295-91	SHORT CHIP		L2000	1-456-551-11	INDUCTOR	0μH	
JR21	1-216-295-91	SHORT CHIP		L2001	1-456-552-11	INDUCTOR	0μH	
JR22	1-216-864-11	SHORT CHIP		L2002	1-456-552-11	INDUCTOR	0μH	
JR30	1-216-864-11	SHORT CHIP		L2003	1-469-320-21	INDUCTOR	100μH	
JR31	1-216-864-11	SHORT CHIP		L2004	1-469-320-21	INDUCTOR	100μH	
JR32	1-216-864-11	SHORT CHIP		L2005	1-456-551-11	INDUCTOR	0μH	
JR33	1-216-864-11	SHORT CHIP		L2006	1-469-317-21	INDUCTOR	10μH	
				L2008	1-414-856-11	INDUCTOR	10μH	
				L2009	1-414-856-11	INDUCTOR	10μH	
				L2010	1-414-856-11	INDUCTOR	10μH	

NOTE: The components identified by shading and  mark are critical for safety. Replace only with part number specified.

NOTE: Les composants identifiés par un trame et une  sont critiques pour la sécurité. Ne les remplacer que par une pièce portant le numéro spécifique.





REF.NO.	PART NO.	DESCRIPTION	VALUES	REF.NO.	PART NO.	DESCRIPTION	VALUES
L2011	1-414-856-11	INDUCTOR	10µH				
 L6000	1-437-479-11	TRANSFORMER, LINE FILTER		R2000	1-216-855-11	METAL CHIP	680K 5% 1/10W
 L6001	1-437-479-11	TRANSFORMER, LINE FILTER		R2001	1-216-864-11	SHORT CHIP	
L6002	1-406-977-21	INDUCTOR	100µH	R2002	1-216-833-11	METAL CHIP	10K 5% 1/10W
L6203	1-412-525-31	INDUCTOR	10µH	R2006	1-216-833-11	METAL CHIP	10K 5% 1/10W
L6204	1-412-525-31	INDUCTOR	10µH	R2007	1-216-839-11	METAL CHIP	33K 5% 1/10W
L6205	1-412-537-31	INDUCTOR	100µH	R2008	1-216-839-11	METAL CHIP	33K 5% 1/10W
L6206	1-456-414-11	COIL, CHOPPER		R2009	1-216-819-11	METAL CHIP	680 5% 1/10W
L6207	1-456-414-11	COIL, CHOPPER		R2010	1-216-819-11	METAL CHIP	680 5% 1/10W
L6208	1-456-414-11	COIL, CHOPPER		R2014	1-216-841-11	METAL CHIP	47K 5% 1/10W
L6209	1-412-525-31	INDUCTOR	10µH	R2015	1-216-830-11	METAL CHIP	5.6K 5% 1/10W
L6210	1-412-525-31	INDUCTOR	10µH	R2018	1-216-829-11	METAL CHIP	4.7K 5% 1/10W
L6211	1-412-525-31	INDUCTOR	10µH	R2019	1-216-829-11	METAL CHIP	4.7K 5% 1/10W
L6212	1-412-537-31	INDUCTOR	100µH	R2020	1-218-871-11	METAL CHIP	10K 0.50% 1/10W
L6213	1-456-214-11	COIL, CHOPPER		R2021	1-216-846-11	METAL CHIP	120K 5% 1/10W
L6215	1-412-525-31	INDUCTOR	10µH	R2023	1-216-846-11	METAL CHIP	120K 5% 1/10W
	<b>IC LINK</b>			R2024	1-216-817-11	METAL CHIP	470 5% 1/10W
PS2000	1-576-390-91	IC LINK	2.5A 50V	R2025	1-216-829-11	METAL CHIP	4.7K 5% 1/10W
PS2001	1-576-390-91	IC LINK	2.5A 50V	R2026	1-216-809-11	METAL CHIP	100 5% 1/10W
	<b>TRANSISTOR</b>			R2027	1-216-843-11	METAL CHIP	68K 5% 1/10W
Q2000	8-729-010-05	TRANSISTOR	MSB709-RT1	R2028	1-218-879-11	METAL CHIP	22K 0.50% 1/10W
Q2001	8-729-010-25	TRANSISTOR	MSD601-RT1	R2029	1-216-829-11	METAL CHIP	4.7K 5% 1/10W
Q2005	8-729-010-25	TRANSISTOR	MSD601-RT1	R2030	1-216-835-11	METAL CHIP	15K 5% 1/10W
Q2006	8-729-010-25	TRANSISTOR	MSD601-RT1	R2032	1-218-879-11	METAL CHIP	22K 0.50% 1/10W
Q2007	8-729-010-05	TRANSISTOR	MSB709-RT1	R2033	1-216-833-11	METAL CHIP	10K 5% 1/10W
Q2008	8-729-010-05	TRANSISTOR	MSB709-RT1	R2034	1-216-833-11	METAL CHIP	10K 5% 1/10W
Q2009	8-729-010-25	TRANSISTOR	MSD601-RT1	R2036	1-216-843-11	METAL CHIP	68K 5% 1/10W
Q2010	8-729-010-05	TRANSISTOR	MSB709-RT1	R2037	1-216-846-11	METAL CHIP	120K 5% 1/10W
Q2011	8-729-010-25	TRANSISTOR	MSD601-RT1	R2038	1-216-821-11	METAL CHIP	1K 5% 1/10W
Q2012	8-729-010-05	TRANSISTOR	MSB709-RT1	R2039	1-216-833-11	METAL CHIP	10K 5% 1/10W
Q2013	8-729-010-05	TRANSISTOR	MSB709-RT1	R2041	1-216-817-11	METAL CHIP	470 5% 1/10W
Q6102	8-729-010-25	TRANSISTOR	MSD601-RT1	R2042	1-216-805-11	METAL CHIP	47 5% 1/10W
Q6105	8-729-010-05	TRANSISTOR	MSB709-RT1	R2043	1-216-821-11	METAL CHIP	1K 5% 1/10W
Q6107	8-729-140-96	TRANSISTOR	2SD774-34	R2044	1-216-841-11	METAL CHIP	47K 5% 1/10W
Q6108	8-729-010-25	TRANSISTOR	MSD601-RT1	R2045	1-216-805-11	METAL CHIP	47 5% 1/10W
Q6109	8-729-010-05	TRANSISTOR	MSB709-RT1	R2046	1-216-829-11	METAL CHIP	4.7K 5% 1/10W
Q6110	8-729-010-05	TRANSISTOR	MSB709-RT1	R2047	1-216-857-11	METAL CHIP	1M 5% 1/10W
Q6111	8-729-010-25	TRANSISTOR	MSD601-RT1	R2048	1-216-847-11	METAL CHIP	150K 5% 1/10W
Q6112	8-729-010-25	TRANSISTOR	MSD601-RT1	R2049	1-216-830-11	METAL CHIP	5.6K 5% 1/10W
Q6209	8-729-010-25	TRANSISTOR	MSD601-RT1	R2050	1-216-841-11	METAL CHIP	47K 5% 1/10W
Q6210	8-729-010-25	TRANSISTOR	MSD601-RT1	R2051	1-216-833-11	METAL CHIP	10K 5% 1/10W
				R2052	1-216-825-11	METAL CHIP	2.2K 5% 1/10W
				R2053	1-216-833-11	METAL CHIP	10K 5% 1/10W
				R2054	1-216-833-11	METAL CHIP	10K 5% 1/10W

NOTE: The components identified by shading and  mark are critical for safety. Replace only with part number specified.

NOTE: Les composants identifiés par un trame et une  sont critiques pour la sécurité. Ne les remplacer que par une pièce portant le numéro spécifique.



REF.NO.	PART NO.	DESCRIPTION	VALUES			REF.NO.	PART NO.	DESCRIPTION	VALUES		
R2057	1-216-827-11	METAL CHIP	3.3K	5%	1/10W	 R6001	1-219-568-91	METAL	8.2M	5%	1/2W
R2058	1-216-819-11	METAL CHIP	680	5%	1/10W	R6002	1-240-303-11	CEMENTED	0.22	5%	10W
R2059	1-216-819-11	METAL CHIP	680	5%	1/10W	R6004	1-240-303-11	CEMENTED	0.22	5%	10W
R2060	1-216-795-11	METAL CHIP	6.8	5%	1/10W	R6012	1-219-510-11	METAL	470K	5%	1/2W
R2061	1-216-829-11	METAL CHIP	4.7K	5%	1/10W	R6013	1-219-510-11	METAL	470K	5%	1/2W
R2062	1-216-837-11	METAL CHIP	22K	5%	1/10W	R6111	1-216-833-11	METAL CHIP	10K	5%	1/10W
R2063	1-216-839-11	METAL CHIP	33K	5%	1/10W	R6113	1-216-821-11	METAL CHIP	1K	5%	1/10W
R2065	1-216-825-11	METAL CHIP	2.2K	5%	1/10W	R6115	1-216-837-11	METAL CHIP	22K	5%	1/10W
R2066	1-216-821-11	METAL CHIP	1K	5%	1/10W	R6116	1-216-833-11	METAL CHIP	10K	5%	1/10W
R2067	1-216-833-11	METAL CHIP	10K	5%	1/10W	R6118	1-216-821-11	METAL CHIP	1K	5%	1/10W
R2068	1-216-833-11	METAL CHIP	10K	5%	1/10W	R6119	1-216-837-11	METAL CHIP	22K	5%	1/10W
R2069	1-216-833-11	METAL CHIP	10K	5%	1/10W	R6120	1-216-841-11	METAL CHIP	47K	5%	1/10W
R2071	1-216-864-11	SHORT CHIP				R6121	1-216-841-11	METAL CHIP	47K	5%	1/10W
R2073	1-216-829-11	METAL CHIP	4.7K	5%	1/10W	R6122	1-216-833-11	METAL CHIP	10K	5%	1/10W
R2076	1-216-833-11	METAL CHIP	10K	5%	1/10W	R6123	1-216-833-11	METAL CHIP	10K	5%	1/10W
R2077	1-216-864-11	SHORT CHIP				R6124	1-216-841-11	METAL CHIP	47K	5%	1/10W
R2079	1-216-833-11	METAL CHIP	10K	5%	1/10W	R6125	1-216-841-11	METAL CHIP	47K	5%	1/10W
R2082	1-216-857-11	METAL CHIP	1M	5%	1/10W	R6126	1-216-837-11	METAL CHIP	22K	5%	1/10W
R2083	1-216-847-11	METAL CHIP	150K	5%	1/10W	R6127	1-216-841-11	METAL CHIP	47K	5%	1/10W
R2084	1-216-833-11	METAL CHIP	10K	5%	1/10W	R6128	1-216-841-11	METAL CHIP	47K	5%	1/10W
R2086	1-216-864-11	SHORT CHIP				R6129	1-216-841-11	METAL CHIP	47K	5%	1/10W
R2087	1-216-825-11	METAL CHIP	2.2K	5%	1/10W	R6130	1-216-841-11	METAL CHIP	47K	5%	1/10W
R2090	1-216-809-11	METAL CHIP	100	5%	1/10W	R6206	1-211-977-11	METAL CHIP	22	0.50%	1/10W
R2091	1-216-809-11	METAL CHIP	100	5%	1/10W	R6207	1-218-859-11	METAL CHIP	3.3K	0.50%	1/10W
R2092	1-216-825-11	METAL CHIP	2.2K	5%	1/10W	R6208	1-211-969-11	METAL CHIP	10	0.50%	1/10W
R2093	1-216-809-11	METAL CHIP	100	5%	1/10W	R6209	1-218-847-11	METAL CHIP	1K	0.50%	1/10W
R2097	1-216-864-11	SHORT CHIP				R6210	1-211-981-11	METAL CHIP	33	0.50%	1/10W
R2098	1-216-821-11	METAL CHIP	1K	5%	1/10W	R6211	1-218-847-11	METAL CHIP	1K	0.50%	1/10W
R2099	1-216-837-11	METAL CHIP	22K	5%	1/10W	R6222	1-216-061-91	RES-CHIP	3.3K	5%	1/10W
R2101	1-216-839-11	METAL CHIP	33K	5%	1/10W	R6223	1-216-837-11	METAL CHIP	22K	5%	1/10W
R2102	1-216-864-11	SHORT CHIP				R6225	1-216-825-11	METAL CHIP	2.2K	5%	1/10W
R2103	1-216-809-11	METAL CHIP	100	5%	1/10W	R6226	1-216-833-11	METAL CHIP	10K	5%	1/10W
R2104	1-216-864-11	SHORT CHIP				R6227	1-211-981-11	METAL CHIP	33	0.50%	1/10W
R2109	1-216-819-11	METAL CHIP	680	5%	1/10W	R6229	1-218-847-11	METAL CHIP	1K	0.50%	1/10W
R2110	1-216-819-11	METAL CHIP	680	5%	1/10W	R6230	1-216-833-11	METAL CHIP	10K	5%	1/10W
R2111	1-216-819-11	METAL CHIP	680	5%	1/10W	R6231	1-216-821-11	METAL CHIP	1K	5%	1/10W
R2112	1-216-819-11	METAL CHIP	680	5%	1/10W	R6232	1-249-377-11	CARBON	0.47	5%	1/4W
R2114	1-216-864-11	SHORT CHIP				R6233	1-249-377-11	CARBON	0.47	5%	1/4W
R2116	1-215-880-00	METAL OXIDE	10	5%	2W						
R2117	1-216-819-11	METAL CHIP	680	5%	1/10W						
R2118	1-215-880-00	METAL OXIDE	10	5%	2W	 RY6000	1-755-395-11	RELAY (AC POWER)			
R2119	1-216-819-11	METAL CHIP	680	5%	1/10W						
R2121	1-216-819-11	METAL CHIP	680	5%	1/10W						
R2123	1-216-819-11	METAL CHIP	680	5%	1/10W						
								<b>RELAY</b>			
								<b>TRANSFORMER</b>			
						T6101	1-437-783-11	TRANSFORMER, STANDBY			

NOTE: The components identified by shading and  $\triangle$  mark are critical for safety. Replace only with part number specified.

NOTE: Les composants identifiés par un triangle et une marque  $\triangle$  sont critiques pour la sécurité. Ne les remplacer que par une pièce portant le numéro spécifique.



REF.NO.	PART NO.	DESCRIPTION	VALUES			REF.NO.	PART NO.	DESCRIPTION	VALUES		
<b><u>TUNER</u></b>						C1544	1-107-826-11	CERAMIC CHIP	0.1 $\mu$ F	10%	16V
$\triangle$ TU2000	8-598-593-20	TUNER, FSS BTF-WA421				C1545	1-107-826-11	CERAMIC CHIP	0.1 $\mu$ F	10%	16V
TU2001	8-598-594-10	TUNER, FSS BTF-FA421				C1546	1-107-826-11	CERAMIC CHIP	0.1 $\mu$ F	10%	16V
<b><u>VARISTOR</u></b>						C1550	1-165-908-11	CERAMIC CHIP	1 $\mu$ F	10%	10V
VD6000	1-804-992-21	VARISTOR				C1551	1-165-908-11	CERAMIC CHIP	1 $\mu$ F	10%	10V
<b><u>CAPACITOR</u></b>						C1552	1-165-908-11	CERAMIC CHIP	1 $\mu$ F	10%	10V
C1501	1-117-720-11	CERAMIC CHIP	4.7 $\mu$ F		10V	C1553	1-165-908-11	CERAMIC CHIP	1 $\mu$ F	10%	10V
C1502	1-107-826-11	CERAMIC CHIP	0.1 $\mu$ F	10%	16V	C1554	1-165-908-11	CERAMIC CHIP	1 $\mu$ F	10%	10V
C1503	1-117-720-11	CERAMIC CHIP	4.7 $\mu$ F		10V	C1555	1-165-908-11	CERAMIC CHIP	1 $\mu$ F	10%	10V
C1504	1-117-720-11	CERAMIC CHIP	4.7 $\mu$ F		10V	C1560	1-117-720-11	CERAMIC CHIP	4.7 $\mu$ F		10V
C1505	1-107-826-11	CERAMIC CHIP	0.1 $\mu$ F	10%	16V	C1561	1-107-826-11	CERAMIC CHIP	0.1 $\mu$ F	10%	16V
C1506	1-117-720-11	CERAMIC CHIP	4.7 $\mu$ F		10V	C1562	1-117-720-11	CERAMIC CHIP	4.7 $\mu$ F		10V
C1507	1-117-720-11	CERAMIC CHIP	4.7 $\mu$ F		10V	C1563	1-107-826-11	CERAMIC CHIP	0.1 $\mu$ F	10%	16V
C1508	1-165-908-11	CERAMIC CHIP	1 $\mu$ F	10%	10V	C1564	1-107-826-11	CERAMIC CHIP	0.1 $\mu$ F	10%	16V
C1509	1-165-908-11	CERAMIC CHIP	1 $\mu$ F	10%	10V	C1565	1-107-826-11	CERAMIC CHIP	0.1 $\mu$ F	10%	16V
C1510	1-165-908-11	CERAMIC CHIP	1 $\mu$ F	10%	10V	C1566	1-109-982-11	CERAMIC CHIP	1 $\mu$ F	10%	10V
C1511	1-165-908-11	CERAMIC CHIP	1 $\mu$ F	10%	10V	C1567	1-162-970-11	CERAMIC CHIP	0.01 $\mu$ F	10%	25V
C1512	1-165-908-11	CERAMIC CHIP	1 $\mu$ F	10%	10V	C1568	1-107-826-11	CERAMIC CHIP	0.1 $\mu$ F	10%	16V
C1513	1-165-908-11	CERAMIC CHIP	1 $\mu$ F	10%	10V	C1569	1-107-826-11	CERAMIC CHIP	0.1 $\mu$ F	10%	16V
C1519	1-162-913-11	CERAMIC CHIP	8pF	0.50pF	50V	C1570	1-164-505-11	CERAMIC CHIP	2.2 $\mu$ F		16V
C1520	1-162-913-11	CERAMIC CHIP	8pF	0.50pF	50V	C1571	1-164-505-11	CERAMIC CHIP	2.2 $\mu$ F		16V
C1523	1-107-826-11	CERAMIC CHIP	0.1 $\mu$ F	10%	16V	C1572	1-117-720-11	CERAMIC CHIP	4.7 $\mu$ F		10V
C1524	1-162-927-11	CERAMIC CHIP	100pF	5%	50V	C1573	1-164-505-11	CERAMIC CHIP	2.2 $\mu$ F		16V
C1525	1-162-919-11	CERAMIC CHIP	22pF	5%	50V	C1574	1-164-505-11	CERAMIC CHIP	2.2 $\mu$ F		16V
C1526	1-126-964-11	ELECT	10 $\mu$ F	20%	50V	C1575	1-117-720-11	CERAMIC CHIP	4.7 $\mu$ F		10V
C1528	1-126-933-11	ELECT	100 $\mu$ F	20%	16V	C1576	1-164-505-11	CERAMIC CHIP	2.2 $\mu$ F		16V
C1530	1-126-964-11	ELECT	10 $\mu$ F	20%	50V	C1577	1-164-505-11	CERAMIC CHIP	2.2 $\mu$ F		16V
C1531	1-126-941-11	ELECT	470 $\mu$ F	20%	25V	C1578	1-164-505-11	CERAMIC CHIP	2.2 $\mu$ F		16V
C1532	1-107-826-11	CERAMIC CHIP	0.1 $\mu$ F	10%	16V	C1579	1-107-826-11	CERAMIC CHIP	0.1 $\mu$ F	10%	16V
C1535	1-126-933-11	ELECT	100 $\mu$ F	20%	16V	C1580	1-107-826-11	CERAMIC CHIP	0.1 $\mu$ F	10%	16V
C1536	1-126-933-11	ELECT	100 $\mu$ F	20%	16V	C1581	1-117-720-11	CERAMIC CHIP	4.7 $\mu$ F		10V
C1537	1-126-933-11	ELECT	100 $\mu$ F	20%	16V	C1582	1-117-720-11	CERAMIC CHIP	4.7 $\mu$ F		10V
C1538	1-126-933-11	ELECT	100 $\mu$ F	20%	16V	C1583	1-107-826-11	CERAMIC CHIP	0.1 $\mu$ F	10%	16V
C1539	1-126-933-11	ELECT	100 $\mu$ F	20%	16V	C1584	1-126-935-11	ELECT	470 $\mu$ F	20%	16V
C1540	1-126-933-11	ELECT	100 $\mu$ F	20%	16V	C1585	1-107-826-11	CERAMIC CHIP	0.1 $\mu$ F	10%	16V
C1541	1-126-933-11	ELECT	100 $\mu$ F	20%	16V	C1586	1-126-935-11	ELECT	470 $\mu$ F	20%	16V
C1542	1-126-941-11	ELECT	470 $\mu$ F	20%	25V	C1587	1-107-826-11	CERAMIC CHIP	0.1 $\mu$ F	10%	16V
C1543	1-126-935-11	ELECT	470 $\mu$ F	20%	16V	C1588	1-107-826-11	CERAMIC CHIP	0.1 $\mu$ F	10%	16V
						C1589	1-107-826-11	CERAMIC CHIP	0.1 $\mu$ F	10%	16V
						C1590	1-107-826-11	CERAMIC CHIP	0.1 $\mu$ F	10%	16V
						C1591	1-126-935-11	ELECT	470 $\mu$ F	20%	16V
						C1592	1-107-826-11	CERAMIC CHIP	0.1 $\mu$ F	10%	16V
						C1593	1-107-826-11	CERAMIC CHIP	0.1 $\mu$ F	10%	16V

\* A-1302-159-A UA BOARD, COMPLETE



REF.NO.	PART NO.	DESCRIPTION	VALUES			REF.NO.	PART NO.	DESCRIPTION	VALUES		
C1594	1-107-826-11	CERAMIC CHIP	0.1µF	10%	16V	C1643	1-107-826-11	CERAMIC CHIP	0.1µF	10%	16V
C1595	1-126-941-11	ELECT	470µF	20%	25V	C1644	1-162-970-11	CERAMIC CHIP	0.01µF	10%	25V
C1596	1-126-933-11	ELECT	100µF	20%	16V	C1645	1-125-891-11	CERAMIC CHIP	0.47µF	10%	10V
C1597	1-126-941-11	ELECT	470µF	20%	25V	C1646	1-162-917-11	CERAMIC CHIP	15pF	5%	50V
C1598	1-107-826-11	CERAMIC CHIP	0.1µF	10%	16V	C1647	1-162-970-11	CERAMIC CHIP	0.01µF	10%	25V
C1599	1-126-933-11	ELECT	100µF	20%	16V	C1648	1-126-963-11	ELECT	4.7µF	20%	50V
C1600	1-107-826-11	CERAMIC CHIP	0.1µF	10%	16V	C1649	1-126-933-11	ELECT	100µF	20%	16V
C1601	1-164-156-11	CERAMIC CHIP	0.1µF		25V	C1650	1-164-156-11	CERAMIC CHIP	0.1µF		25V
C1602	1-165-908-11	CERAMIC CHIP	1µF	10%	10V	C1651	1-125-891-11	CERAMIC CHIP	0.47µF	10%	10V
C1603	1-165-908-11	CERAMIC CHIP	1µF	10%	10V	C1652	1-125-891-11	CERAMIC CHIP	0.47µF	10%	10V
C1604	1-126-964-11	ELECT	10µF	20%	50V	C1653	1-165-908-11	CERAMIC CHIP	1µF	10%	10V
C1610	1-126-933-11	ELECT	100µF	20%	16V	C1654	1-165-908-11	CERAMIC CHIP	1µF	10%	10V
C1611	1-164-156-11	CERAMIC CHIP	0.1µF		25V	C1655	1-165-908-11	CERAMIC CHIP	1µF	10%	10V
C1612	1-164-156-11	CERAMIC CHIP	0.1µF		25V	C1656	1-165-908-11	CERAMIC CHIP	1µF	10%	10V
C1613	1-162-964-11	CERAMIC CHIP	0.001µF	10%	50V	C1657	1-165-908-11	CERAMIC CHIP	1µF	10%	10V
C1614	1-164-227-11	CERAMIC CHIP	0.022µF	10%	25V	C1658	1-165-908-11	CERAMIC CHIP	1µF	10%	10V
C1615	1-164-156-11	CERAMIC CHIP	0.1µF		25V	C1661	1-126-933-11	ELECT	100µF	20%	16V
C1616	1-107-826-11	CERAMIC CHIP	0.1µF	10%	16V	C1662	1-164-156-11	CERAMIC CHIP	0.1µF		25V
C1617	1-107-826-11	CERAMIC CHIP	0.1µF	10%	16V	C1663	1-126-933-11	ELECT	100µF	20%	16V
C1618	1-126-933-11	ELECT	100µF	20%	16V	<b>CONNECTOR</b>					
C1619	1-107-826-11	CERAMIC CHIP	0.1µF	10%	16V	*	CN1501	1-564-526-11	PLUG, CONNECTOR		11P
C1620	1-107-826-11	CERAMIC CHIP	0.1µF	10%	16V	*	CN1502	1-793-498-11	CONNECTOR, BOARD TO BOARD		50P
C1621	1-107-826-11	CERAMIC CHIP	0.1µF	10%	16V	*	CN1503	1-564-524-11	PLUG, CONNECTOR		9P
C1622	1-164-156-11	CERAMIC CHIP	0.1µF		25V	*	CN1504	1-817-565-11	CONNECTOR, BOARD TO BOARD		11P
C1623	1-126-963-11	ELECT	4.7µF	20%	50V	*	CN1506	1-564-519-11	PLUG, CONNECTOR		4P
C1624	1-164-156-11	CERAMIC CHIP	0.1µF		25V		CN1508	1-815-468-11	PIN, CONNECTOR (PC BOARD)		
C1625	1-126-933-11	ELECT	100µF	20%	16V	<b>DIODE</b>					
C1626	1-164-156-11	CERAMIC CHIP	0.1µF		25V	D1501	8-719-977-28	DIODE			DTZ10B
C1627	1-164-156-11	CERAMIC CHIP	0.1µF		25V	D1502	8-719-977-28	DIODE			DTZ10B
C1628	1-164-156-11	CERAMIC CHIP	0.1µF		25V	D1503	8-719-977-28	DIODE			DTZ10B
C1629	1-126-933-11	ELECT	100µF	20%	16V	D1505	8-719-977-28	DIODE			DTZ10B
C1630	1-126-933-11	ELECT	100µF	20%	16V	D1506	8-719-977-28	DIODE			DTZ10B
C1631	1-164-156-11	CERAMIC CHIP	0.1µF		25V	D1507	8-719-977-28	DIODE			DTZ10B
C1632	1-107-826-11	CERAMIC CHIP	0.1µF	10%	16V	D1508	8-719-977-28	DIODE			DTZ10B
C1633	1-162-917-11	CERAMIC CHIP	15pF	5%	50V	D1509	8-719-977-28	DIODE			DTZ10B
C1634	1-162-917-11	CERAMIC CHIP	15pF	5%	50V	D1510	8-719-977-28	DIODE			DTZ10B
C1635	1-125-891-11	CERAMIC CHIP	0.47µF	10%	10V	D1511	8-719-977-28	DIODE			DTZ10B
C1636	1-164-315-11	CERAMIC CHIP	470pF	5%	50V	D1512	8-719-977-28	DIODE			DTZ10B
C1637	1-126-964-11	ELECT	10µF	20%	50V	D1513	8-719-977-28	DIODE			DTZ10B
C1638	1-125-891-11	CERAMIC CHIP	0.47µF	10%	10V	D1514	8-719-977-28	DIODE			DTZ10B
C1639	1-107-826-11	CERAMIC CHIP	0.1µF	10%	16V	D1515	8-719-977-28	DIODE			DTZ10B
C1640	1-162-917-11	CERAMIC CHIP	15pF	5%	50V	D1516	8-719-977-28	DIODE			DTZ10B
C1641	1-164-156-11	CERAMIC CHIP	0.1µF		25V						
C1642	1-164-156-11	CERAMIC CHIP	0.1µF		25V						





REF.NO.	PART NO.	DESCRIPTION	VALUES	REF.NO.	PART NO.	DESCRIPTION	VALUES
D1517	8-719-977-28	DIODE	DTZ10B			<b><u>JACK</u></b>	
D1519	8-719-977-28	DIODE	DTZ10B	J1501	1-573-967-12	BLOCK, (S) TERMINAL	
D1520	8-719-977-28	DIODE	DTZ10B	J1502	1-750-516-21	JACK BLOCK, PIN	2P
D1521	8-719-977-28	DIODE	DTZ10B	J1503	1-750-517-21	JACK BLOCK, PIN	3P
D1522	8-719-977-28	DIODE	DTZ10B	J1504	1-750-517-21	JACK BLOCK, PIN	3P
D1525	8-719-977-28	DIODE	DTZ10B	J1505	1-764-143-11	JACK	
D1526	8-719-977-28	DIODE	DTZ10B	J1506	1-764-143-11	JACK	
D1527	8-719-977-28	DIODE	DTZ10B	J1508	1-815-015-11	JACK BLOCK, PIN	
D1528	8-719-977-28	DIODE	DTZ10B	J1509	1-815-015-11	JACK BLOCK, PIN	
D1529	8-719-977-28	DIODE	DTZ10B				
D1530	8-719-977-28	DIODE	DTZ10B			<b><u>COIL</u></b>	
D1531	8-719-977-28	DIODE	DTZ10B	L1501	1-400-397-11	INDUCTOR	10µH
D1532	8-719-977-28	DIODE	DTZ10B	L1502	1-400-397-11	INDUCTOR	10µH
D1533	8-719-977-28	DIODE	DTZ10B	L1503	1-400-397-11	INDUCTOR	10µH
D1534	8-719-977-28	DIODE	DTZ10B	L1504	1-400-397-11	INDUCTOR	10µH
D1535	8-719-977-28	DIODE	DTZ10B	L1505	1-400-397-11	INDUCTOR	10µH
D1536	8-719-914-43	DIODE	DAN202K	L1506	1-400-397-11	INDUCTOR	10µH
D1538	8-719-977-28	DIODE	DTZ10B	L1507	1-400-397-11	INDUCTOR	10µH
D1539	8-719-977-28	DIODE	DTZ10B	L1508	1-400-397-11	INDUCTOR	10µH
D1545	8-719-977-28	DIODE	DTZ10B	L1510	1-400-397-11	INDUCTOR	10µH
D1546	8-719-977-28	DIODE	DTZ10B	L1511	1-400-397-11	INDUCTOR	10µH
D1547	8-719-977-28	DIODE	DTZ10B	L1512	1-400-397-11	INDUCTOR	10µH
D1548	8-719-977-28	DIODE	DTZ10B	L1513	1-400-397-11	INDUCTOR	10µH
D1549	8-719-977-28	DIODE	DTZ10B	L1514	1-400-397-11	INDUCTOR	10µH
				L1515	1-414-856-11	INDUCTOR	10µH
				L1516	1-414-856-11	INDUCTOR	10µH
				L1601	1-400-397-11	INDUCTOR	10µH
						<b><u>TRANSISTOR</u></b>	
				Q1501	8-729-010-05	TRANSISTOR	MSB709-RT1
				Q1502	8-729-010-05	TRANSISTOR	MSB709-RT1
				Q1503	8-729-010-05	TRANSISTOR	MSB709-RT1
				Q1504	8-729-010-05	TRANSISTOR	MSB709-RT1
				Q1505	8-729-010-05	TRANSISTOR	MSB709-RT1
				Q1506	8-729-010-05	TRANSISTOR	MSB709-RT1
				Q1507	8-729-010-05	TRANSISTOR	MSB709-RT1
				Q1508	8-729-010-25	TRANSISTOR	MSD601-RT1
				Q1510	8-729-010-25	TRANSISTOR	MSD601-RT1
				Q1511	8-729-122-63	TRANSISTOR	2SA1226-E4
				Q1512	8-729-122-63	TRANSISTOR	2SA1226-E4
				Q1513	8-729-122-63	TRANSISTOR	2SA1226-E4
				Q1514	8-729-010-05	TRANSISTOR	MSB709-RT1
				Q1515	8-729-010-05	TRANSISTOR	MSB709-RT1
				Q1523	8-729-010-25	TRANSISTOR	MSD601-RT1
<b><u>FERRITE BEAD</u></b>							
FB1501	1-414-229-11	FERRITE	0µH				
FB1502	1-414-229-11	FERRITE	0µH				
<b><u>FILTER</u></b>							
FL1501	1-239-848-21	FILTER, LOW PASS					
FL1502	1-239-848-21	FILTER, LOW PASS					
FL1503	1-239-848-21	FILTER, LOW PASS					
<b><u>IC</u></b>							
IC1501	8-752-108-00	IC	CXA2189Q-TL				
IC1502	8-752-107-98	IC	CXA2188Q-T4				
IC1503	8-759-548-56	IC	M52055FP				
IC1504	8-759-450-93	IC	NJM2521M-TE1				
IC1505	8-759-450-93	IC	NJM2521M-TE1				
IC1506	8-752-394-69	IC	CXD2073Q-T4				
IC1507	8-752-102-21	IC	CXA2103AQ				
IC1601	8-759-331-71	IC	NJM4558E(TE2)				



REF.NO.	PART NO.	DESCRIPTION	VALUES			REF.NO.	PART NO.	DESCRIPTION	VALUES		
Q1524	8-729-010-25	TRANSISTOR	MSD601-RT1			R1526	1-216-821-11	METAL CHIP	1K	5%	1/10W
Q1525	8-729-010-05	TRANSISTOR	MSB709-RT1			R1527	1-216-821-11	METAL CHIP	1K	5%	1/10W
Q1526	8-729-010-25	TRANSISTOR	MSD601-RT1			R1530	1-216-809-11	METAL CHIP	100	5%	1/10W
Q1527	8-729-010-05	TRANSISTOR	MSB709-RT1			R1531	1-216-809-11	METAL CHIP	100	5%	1/10W
Q1528	8-729-010-05	TRANSISTOR	MSB709-RT1			R1532	1-216-809-11	METAL CHIP	100	5%	1/10W
Q1529	8-729-010-25	TRANSISTOR	MSD601-RT1			R1533	1-216-825-11	METAL CHIP	2.2K	5%	1/10W
Q1530	8-729-010-25	TRANSISTOR	MSD601-RT1			R1534	1-216-833-11	METAL CHIP	10K	5%	1/10W
Q1531	8-729-010-25	TRANSISTOR	MSD601-RT1			R1535	1-216-821-11	METAL CHIP	1K	5%	1/10W
Q1535	8-729-010-25	TRANSISTOR	MSD601-RT1			R1536	1-216-821-11	METAL CHIP	1K	5%	1/10W
Q1536	8-729-010-25	TRANSISTOR	MSD601-RT1			R1537	1-216-821-11	METAL CHIP	1K	5%	1/10W
Q1537	8-729-010-25	TRANSISTOR	MSD601-RT1			R1538	1-216-808-11	METAL CHIP	82	5%	1/10W
Q1538	8-729-010-05	TRANSISTOR	MSB709-RT1			R1541	1-216-861-11	METAL CHIP	2.2M	5%	1/10W
Q1539	8-729-010-25	TRANSISTOR	MSD601-RT1			R1542	1-216-861-11	METAL CHIP	2.2M	5%	1/10W
Q1540	8-729-010-25	TRANSISTOR	MSD601-RT1			R1544	1-216-809-11	METAL CHIP	100	5%	1/10W
Q1541	8-729-010-25	TRANSISTOR	MSD601-RT1			R1545	1-216-809-11	METAL CHIP	100	5%	1/10W
Q1542	8-729-010-05	TRANSISTOR	MSB709-RT1			R1548	1-216-841-11	METAL CHIP	47K	5%	1/10W
Q1543	8-729-010-25	TRANSISTOR	MSD601-RT1			R1549	1-216-809-11	METAL CHIP	100	5%	1/10W
Q1544	8-729-010-05	TRANSISTOR	MSB709-RT1			R1550	1-216-809-11	METAL CHIP	100	5%	1/10W
Q1545	8-729-010-25	TRANSISTOR	MSD601-RT1			R1551	1-216-853-11	METAL CHIP	470K	5%	1/10W
Q1546	8-729-010-25	TRANSISTOR	MSD601-RT1			R1552	1-216-821-11	METAL CHIP	1K	5%	1/10W
Q1547	8-729-010-05	TRANSISTOR	MSB709-RT1			R1553	1-216-819-11	METAL CHIP	680	5%	1/10W
Q1548	8-729-010-05	TRANSISTOR	MSB709-RT1			R1554	1-216-819-11	METAL CHIP	680	5%	1/10W
						R1555	1-216-853-11	METAL CHIP	470K	5%	1/10W
						R1556	1-216-853-11	METAL CHIP	470K	5%	1/10W
						R1558	1-216-821-11	METAL CHIP	1K	5%	1/10W
						R1559	1-218-285-11	METAL CHIP	75	5%	1/10W
						R1560	1-216-809-11	METAL CHIP	100	5%	1/10W
						R1561	1-216-809-11	METAL CHIP	100	5%	1/10W
						R1562	1-216-809-11	METAL CHIP	100	5%	1/10W
						R1563	1-216-843-11	METAL CHIP	68K	5%	1/10W
						R1564	1-216-833-11	METAL CHIP	10K	5%	1/10W
						R1565	1-216-809-11	METAL CHIP	100	5%	1/10W
						R1566	1-216-809-11	METAL CHIP	100	5%	1/10W
						R1567	1-216-809-11	METAL CHIP	100	5%	1/10W
						R1568	1-216-809-11	METAL CHIP	100	5%	1/10W
						R1569	1-216-809-11	METAL CHIP	100	5%	1/10W
						R1570	1-216-809-11	METAL CHIP	100	5%	1/10W
						R1571	1-216-809-11	METAL CHIP	100	5%	1/10W
						R1572	1-216-809-11	METAL CHIP	100	5%	1/10W
						R1573	1-216-809-11	METAL CHIP	100	5%	1/10W
						R1574	1-216-843-11	METAL CHIP	68K	5%	1/10W
						R1575	1-216-809-11	METAL CHIP	100	5%	1/10W
						R1576	1-216-809-11	METAL CHIP	100	5%	1/10W

**RESISTOR**



REF.NO.	PART NO.	DESCRIPTION	VALUES			REF.NO.	PART NO.	DESCRIPTION	VALUES		
R1578	1-216-813-11	METAL CHIP	220	5%	1/10W	R1630	1-216-819-11	METAL CHIP	680	5%	1/10W
R1579	1-216-813-11	METAL CHIP	220	5%	1/10W	R1631	1-216-819-11	METAL CHIP	680	5%	1/10W
R1580	1-216-809-11	METAL CHIP	100	5%	1/10W	R1632	1-216-819-11	METAL CHIP	680	5%	1/10W
R1581	1-216-809-11	METAL CHIP	100	5%	1/10W	R1633	1-216-845-11	METAL CHIP	100K	5%	1/10W
R1583	1-216-809-11	METAL CHIP	100	5%	1/10W	R1634	1-216-833-11	METAL CHIP	10K	5%	1/10W
R1584	1-216-809-11	METAL CHIP	100	5%	1/10W	R1635	1-216-821-11	METAL CHIP	1K	5%	1/10W
R1585	1-216-809-11	METAL CHIP	100	5%	1/10W	R1636	1-216-833-11	METAL CHIP	10K	5%	1/10W
R1587	1-216-809-11	METAL CHIP	100	5%	1/10W	R1637	1-216-857-11	METAL CHIP	1M	5%	1/10W
R1588	1-216-809-11	METAL CHIP	100	5%	1/10W	R1638	1-216-842-11	METAL CHIP	56K	5%	1/10W
R1589	1-216-809-11	METAL CHIP	100	5%	1/10W	R1639	1-216-829-11	METAL CHIP	4.7K	5%	1/10W
R1591	1-216-809-11	METAL CHIP	100	5%	1/10W	R1640	1-216-821-11	METAL CHIP	1K	5%	1/10W
R1592	1-216-809-11	METAL CHIP	100	5%	1/10W	R1641	1-216-813-11	METAL CHIP	220	5%	1/10W
R1593	1-216-809-11	METAL CHIP	100	5%	1/10W	R1642	1-216-833-11	METAL CHIP	10K	5%	1/10W
R1594	1-216-813-11	METAL CHIP	220	5%	1/10W	R1643	1-216-809-11	METAL CHIP	100	5%	1/10W
R1595	1-216-813-11	METAL CHIP	220	5%	1/10W	R1644	1-216-809-11	METAL CHIP	100	5%	1/10W
R1596	1-216-809-11	METAL CHIP	100	5%	1/10W	R1646	1-216-821-11	METAL CHIP	1K	5%	1/10W
R1597	1-216-809-11	METAL CHIP	100	5%	1/10W	R1649	1-216-811-11	METAL CHIP	150	5%	1/10W
R1598	1-216-817-11	METAL CHIP	470	5%	1/10W	R1650	1-216-811-11	METAL CHIP	150	5%	1/10W
R1599	1-216-817-11	METAL CHIP	470	5%	1/10W	R1651	1-216-811-11	METAL CHIP	150	5%	1/10W
R1600	1-216-817-11	METAL CHIP	470	5%	1/10W	R1652	1-216-811-11	METAL CHIP	150	5%	1/10W
R1601	1-216-817-11	METAL CHIP	470	5%	1/10W	R1653	1-216-811-11	METAL CHIP	150	5%	1/10W
R1602	1-216-817-11	METAL CHIP	470	5%	1/10W	R1654	1-216-811-11	METAL CHIP	150	5%	1/10W
R1603	1-216-817-11	METAL CHIP	470	5%	1/10W	R1655	1-216-811-11	METAL CHIP	150	5%	1/10W
R1604	1-216-817-11	METAL CHIP	470	5%	1/10W	R1656	1-216-811-11	METAL CHIP	150	5%	1/10W
R1605	1-216-817-11	METAL CHIP	470	5%	1/10W	R1657	1-216-811-11	METAL CHIP	150	5%	1/10W
R1606	1-216-817-11	METAL CHIP	470	5%	1/10W	R1658	1-216-811-11	METAL CHIP	150	5%	1/10W
R1607	1-216-817-11	METAL CHIP	470	5%	1/10W	R1659	1-216-811-11	METAL CHIP	150	5%	1/10W
R1608	1-216-817-11	METAL CHIP	470	5%	1/10W	R1660	1-216-811-11	METAL CHIP	150	5%	1/10W
R1609	1-216-817-11	METAL CHIP	470	5%	1/10W	R1661	1-216-849-11	METAL CHIP	220K	5%	1/10W
R1610	1-216-817-11	METAL CHIP	470	5%	1/10W	R1662	1-216-825-11	METAL CHIP	2.2K	5%	1/10W
R1611	1-216-817-11	METAL CHIP	470	5%	1/10W	R1663	1-216-849-11	METAL CHIP	220K	5%	1/10W
R1612	1-216-817-11	METAL CHIP	470	5%	1/10W	R1664	1-216-841-11	METAL CHIP	47K	5%	1/10W
R1613	1-216-817-11	METAL CHIP	470	5%	1/10W	R1665	1-216-845-11	METAL CHIP	100K	5%	1/10W
R1614	1-216-817-11	METAL CHIP	470	5%	1/10W	R1666	1-216-833-11	METAL CHIP	10K	5%	1/10W
R1615	1-216-817-11	METAL CHIP	470	5%	1/10W	R1667	1-216-864-11	SHORT CHIP			
R1616	1-216-817-11	METAL CHIP	470	5%	1/10W	R1668	1-216-845-11	METAL CHIP	100K	5%	1/10W
R1617	1-216-817-11	METAL CHIP	470	5%	1/10W	R1669	1-216-833-11	METAL CHIP	10K	5%	1/10W
R1618	1-216-809-11	METAL CHIP	100	5%	1/10W	R1670	1-216-849-11	METAL CHIP	220K	5%	1/10W
R1619	1-216-809-11	METAL CHIP	100	5%	1/10W	R1671	1-216-845-11	METAL CHIP	100K	5%	1/10W
R1620	1-216-809-11	METAL CHIP	100	5%	1/10W	R1677	1-216-853-11	METAL CHIP	470K	5%	1/10W
R1623	1-216-853-11	METAL CHIP	470K	5%	1/10W	R1678	1-216-853-11	METAL CHIP	470K	5%	1/10W
R1624	1-216-853-11	METAL CHIP	470K	5%	1/10W	R1679	1-216-809-11	METAL CHIP	100	5%	1/10W
R1628	1-216-853-11	METAL CHIP	470K	5%	1/10W	R1683	1-216-809-11	METAL CHIP	100	5%	1/10W
R1629	1-216-853-11	METAL CHIP	470K	5%	1/10W	R1684	1-216-864-11	SHORT CHIP			



REF.NO.	PART NO.	DESCRIPTION	VALUES			REF.NO.	PART NO.	DESCRIPTION	VALUES		
R1685	1-216-864-11	SHORT CHIP				R1743	1-216-828-11	METAL CHIP	3.9K	5%	1/10W
R1686	1-216-864-11	SHORT CHIP				R1744	1-216-821-11	METAL CHIP	1K	5%	1/10W
R1687	1-216-821-11	METAL CHIP	1K	5%	1/10W	R1745	1-216-821-11	METAL CHIP	1K	5%	1/10W
R1688	1-216-821-11	METAL CHIP	1K	5%	1/10W	R1746	1-216-825-11	METAL CHIP	2.2K	5%	1/10W
R1689	1-216-821-11	METAL CHIP	1K	5%	1/10W	R1747	1-216-821-11	METAL CHIP	1K	5%	1/10W
R1698	1-216-809-11	METAL CHIP	100	5%	1/10W	R1748	1-216-821-11	METAL CHIP	1K	5%	1/10W
R1699	1-216-809-11	METAL CHIP	100	5%	1/10W	R1749	1-216-825-11	METAL CHIP	2.2K	5%	1/10W
R1700	1-216-809-11	METAL CHIP	100	5%	1/10W	R1757	1-218-285-11	METAL CHIP	75	5%	1/10W
R1701	1-216-809-11	METAL CHIP	100	5%	1/10W	R1758	1-218-285-11	METAL CHIP	75	5%	1/10W
R1702	1-216-864-11	SHORT CHIP				R1759	1-218-285-11	METAL CHIP	75	5%	1/10W
R1703	1-216-864-11	SHORT CHIP				R1760	1-216-864-11	SHORT CHIP			
R1704	1-216-864-11	SHORT CHIP				R1761	1-216-864-11	SHORT CHIP			
R1711	1-216-821-11	METAL CHIP	1K	5%	1/10W	R1762	1-216-806-11	METAL CHIP	56	5%	1/10W
R1712	1-216-864-11	SHORT CHIP				R1763	1-216-806-11	METAL CHIP	56	5%	1/10W
R1713	1-218-841-11	METAL CHIP	560	0.50%	1/10W	R1764	1-216-806-11	METAL CHIP	56	5%	1/10W
R1714	1-218-889-11	METAL CHIP	56K	0.50%	1/10W	R1765	1-216-837-11	METAL CHIP	22K	5%	1/10W
R1715	1-218-859-11	METAL CHIP	3.3K	0.50%	1/10W	R1766	1-216-837-11	METAL CHIP	22K	5%	1/10W
R1716	1-218-859-11	METAL CHIP	3.3K	0.50%	1/10W	R1767	1-216-841-11	METAL CHIP	47K	5%	1/10W
R1717	1-218-855-11	METAL CHIP	2.2K	0.50%	1/10W	R1768	1-216-841-11	METAL CHIP	47K	5%	1/10W
R1718	1-216-837-11	METAL CHIP	22K	5%	1/10W	R1769	1-216-845-11	METAL CHIP	100K	5%	1/10W
R1719	1-216-809-11	METAL CHIP	100	5%	1/10W	R1770	1-216-845-11	METAL CHIP	100K	5%	1/10W
R1720	1-218-841-11	METAL CHIP	560	0.50%	1/10W						
R1721	1-216-821-11	METAL CHIP	1K	5%	1/10W						
R1722	1-216-811-11	METAL CHIP	150	5%	1/10W						
R1723	1-216-839-11	METAL CHIP	33K	5%	1/10W						
R1724	1-216-817-11	METAL CHIP	470	5%	1/10W						
R1725	1-218-865-11	METAL CHIP	5.6K	0.50%	1/10W						
R1726	1-216-835-11	METAL CHIP	15K	5%	1/10W						
R1727	1-218-841-11	METAL CHIP	560	0.50%	1/10W						
R1728	1-216-817-11	METAL CHIP	470	5%	1/10W						
R1729	1-216-809-11	METAL CHIP	100	5%	1/10W						
R1730	1-218-841-11	METAL CHIP	560	0.50%	1/10W						
R1731	1-218-864-11	METAL CHIP	5.1K	0.50%	1/10W						
R1732	1-216-821-11	METAL CHIP	1K	5%	1/10W						
R1733	1-216-837-11	METAL CHIP	22K	5%	1/10W						
R1734	1-216-809-11	METAL CHIP	100	5%	1/10W						
R1735	1-218-841-11	METAL CHIP	560	0.50%	1/10W						
R1736	1-216-812-11	METAL CHIP	180	5%	1/10W						
R1737	1-216-839-11	METAL CHIP	33K	5%	1/10W						
R1738	1-218-865-11	METAL CHIP	5.6K	0.50%	1/10W						
R1739	1-216-809-11	METAL CHIP	100	5%	1/10W						
R1740	1-216-809-11	METAL CHIP	100	5%	1/10W						
R1741	1-216-817-11	METAL CHIP	470	5%	1/10W						
R1742	1-216-817-11	METAL CHIP	470	5%	1/10W						

VARISTOR

VD1534	1-803-974-21	VARISTOR, CHIP	(1608)
VD1535	1-803-974-21	VARISTOR, CHIP	(1608)
VD1536	1-803-974-21	VARISTOR, CHIP	(1608)
VD1537	1-803-974-21	VARISTOR, CHIP	(1608)
VD1538	1-803-974-21	VARISTOR, CHIP	(1608)

VD1539	1-803-974-21	VARISTOR, CHIP	(1608)
VD1540	1-803-974-21	VARISTOR, CHIP	(1608)

CRYSTAL

X1501	1-781-282-11	VIBRATOR, CERAMIC
X1502	1-781-131-31	VIBRATOR, CRYSTAL



REF.NO.	PART NO.	DESCRIPTION	VALUES			REF.NO.	PART NO.	DESCRIPTION	VALUES		
						C9639	1-125-837-91	CERAMIC CHIP	1μF	10%	6.3V
						C9640	1-125-837-91	CERAMIC CHIP	1μF	10%	6.3V
<p>Due to the complexity of this board, performing component level field repairs is not recommended. If service is required, complete board replacement is the preferred repair method. Data is provided for reference only.</p> <p>* A-1302-160-A AD BOARD, COMPLETE</p> <p><u>CAPACITOR</u></p>						C9641	1-125-837-91	CERAMIC CHIP	1μF	10%	6.3V
						C9642	1-125-837-91	CERAMIC CHIP	1μF	10%	6.3V
						C9643	1-125-837-91	CERAMIC CHIP	1μF	10%	6.3V
						C9644	1-125-837-91	CERAMIC CHIP	1μF	10%	6.3V
						C9647	1-107-826-11	CERAMIC CHIP	0.1μF	10%	16V
						C9648	1-125-837-91	CERAMIC CHIP	1μF	10%	6.3V
						C9649	1-107-826-11	CERAMIC CHIP	0.1μF	10%	16V
						C9650	1-107-826-11	CERAMIC CHIP	0.1μF	10%	16V
						C9651	1-164-218-11	CERAMIC CHIP	180pF	5%	50V
						C9652	1-126-933-11	ELECT	100μF	20%	16V
C9600	1-164-392-11	CERAMIC CHIP	390pF	5%	50V	C9653	1-107-826-11	CERAMIC CHIP	0.1μF	10%	16V
C9601	1-107-826-11	CERAMIC CHIP	0.1μF	10%	16V	C9654	1-107-826-11	CERAMIC CHIP	0.1μF	10%	16V
C9602	1-107-826-11	CERAMIC CHIP	0.1μF	10%	16V	C9655	1-162-915-11	CERAMIC CHIP	10pF	0.50pF	50V
C9603	1-107-826-11	CERAMIC CHIP	0.1μF	10%	16V	C9656	1-162-915-11	CERAMIC CHIP	10pF	0.50pF	50V
C9604	1-162-927-11	CERAMIC CHIP	100pF	5%	50V	C9657	1-125-837-91	CERAMIC CHIP	1μF	10%	6.3V
C9605	1-162-965-11	CERAMIC CHIP	0.0015μF	10%	50V	C9658	1-107-826-11	CERAMIC CHIP	0.1μF	10%	16V
C9606	1-162-965-11	CERAMIC CHIP	0.0015μF	10%	50V	C9659	1-107-826-11	CERAMIC CHIP	0.1μF	10%	16V
C9607	1-115-416-11	CERAMIC CHIP	0.001μF	5%	25V	C9660	1-125-837-91	CERAMIC CHIP	1μF	10%	6.3V
C9608	1-107-826-11	CERAMIC CHIP	0.1μF	10%	16V	C9661	1-107-826-11	CERAMIC CHIP	0.1μF	10%	16V
C9609	1-162-965-11	CERAMIC CHIP	0.0015μF	10%	50V	C9662	1-125-837-91	CERAMIC CHIP	1μF	10%	6.3V
C9610	1-162-965-11	CERAMIC CHIP	0.0015μF	10%	50V	C9663	1-125-837-91	CERAMIC CHIP	1μF	10%	6.3V
C9611	1-164-156-11	CERAMIC CHIP	0.1μF	25V		C9664	1-125-837-91	CERAMIC CHIP	1μF	10%	6.3V
C9612	1-164-156-11	CERAMIC CHIP	0.1μF	25V		C9666	1-125-837-91	CERAMIC CHIP	1μF	10%	6.3V
C9613	1-162-970-11	CERAMIC CHIP	0.01μF	10%	25V	C9668	1-125-837-91	CERAMIC CHIP	1μF	10%	6.3V
C9614	1-162-925-11	CERAMIC CHIP	68pF	5%	50V	C9672	1-164-315-11	CERAMIC CHIP	470pF	5%	50V
C9615	1-164-315-11	CERAMIC CHIP	470pF	5%	50V	C9676	1-162-925-11	CERAMIC CHIP	68pF	5%	50V
C9616	1-125-837-91	CERAMIC CHIP	1μF	10%	6.3V	C9677	1-126-933-11	ELECT	100μF	20%	16V
C9617	1-164-218-11	CERAMIC CHIP	180pF	5%	50V	C9678	1-107-826-11	CERAMIC CHIP	0.1μF	10%	16V
C9618	1-107-826-11	CERAMIC CHIP	0.1μF	10%	16V	C9679	1-107-826-11	CERAMIC CHIP	0.1μF	10%	16V
C9619	1-107-826-11	CERAMIC CHIP	0.1μF	10%	16V	C9680	1-107-826-11	CERAMIC CHIP	0.1μF	10%	16V
C9621	1-107-826-11	CERAMIC CHIP	0.1μF	10%	16V	C9681	1-107-826-11	CERAMIC CHIP	0.1μF	10%	16V
C9622	1-126-933-11	ELECT	100μF	20%	16V	C9682	1-107-826-11	CERAMIC CHIP	0.1μF	10%	16V
C9623	1-107-826-11	CERAMIC CHIP	0.1μF	10%	16V	C9683	1-107-826-11	CERAMIC CHIP	0.1μF	10%	16V
C9624	1-107-826-11	CERAMIC CHIP	0.1μF	10%	16V	C9684	1-125-837-91	CERAMIC CHIP	1μF	10%	6.3V
C9625	1-107-826-11	CERAMIC CHIP	0.1μF	10%	16V	C9685	1-125-837-91	CERAMIC CHIP	1μF	10%	6.3V
C9626	1-107-826-11	CERAMIC CHIP	0.1μF	10%	16V	C9686	1-125-837-91	CERAMIC CHIP	1μF	10%	6.3V
C9627	1-107-826-11	CERAMIC CHIP	0.1μF	10%	16V	C9687	1-162-921-11	CERAMIC CHIP	33pF	5%	50V
C9628	1-107-826-11	CERAMIC CHIP	0.1μF	10%	16V	C9688	1-162-921-11	CERAMIC CHIP	33pF	5%	50V
C9629	1-107-826-11	CERAMIC CHIP	0.1μF	10%	16V	C9689	1-162-921-11	CERAMIC CHIP	33pF	5%	50V
C9630	1-107-826-11	CERAMIC CHIP	0.1μF	10%	16V	C9709	1-125-837-91	CERAMIC CHIP	1μF	10%	6.3V
C9631	1-107-826-11	CERAMIC CHIP	0.1μF	10%	16V	C9710	1-125-837-91	CERAMIC CHIP	1μF	10%	6.3V
C9632	1-107-826-11	CERAMIC CHIP	0.1μF	10%	16V	C9711	1-125-837-91	CERAMIC CHIP	1μF	10%	6.3V
C9633	1-162-925-11	CERAMIC CHIP	68pF	5%	50V	C9712	1-164-218-11	CERAMIC CHIP	180pF	5%	50V
C9636	1-164-315-11	CERAMIC CHIP	470pF	5%	50V						
C9637	1-125-837-91	CERAMIC CHIP	1μF	10%	6.3V						



REF.NO.	PART NO.	DESCRIPTION	VALUES	REF.NO.	PART NO.	DESCRIPTION	VALUES
C9718	1-125-837-91	CERAMIC CHIP	1 $\mu$ F 10% 6.3V	FB9626	1-414-445-11	FERRITE	0 $\mu$ H
C9719	1-126-933-11	ELECT	100 $\mu$ F 20% 16V	FB9627	1-414-445-11	FERRITE	0 $\mu$ H
C9720	1-107-826-11	CERAMIC CHIP	0.1 $\mu$ F 10% 16V	FB9628	1-414-445-11	FERRITE	0 $\mu$ H
C9721	1-107-826-11	CERAMIC CHIP	0.1 $\mu$ F 10% 16V	FB9629	1-414-445-11	FERRITE	0 $\mu$ H
<b>CONNECTOR</b>				FB9630	1-414-445-11	FERRITE	0 $\mu$ H
*	CN9600	1-564-511-11	PLUG, CONNECTOR 8P	FB9631	1-414-445-11	FERRITE	0 $\mu$ H
*	CN9601	1-793-497-11	CONNECTOR, BOARD TO BOARD 40P	FB9632	1-414-445-11	FERRITE	0 $\mu$ H
<b>DIODE</b>				FB9633	1-414-445-11	FERRITE	0 $\mu$ H
D9600	8-719-976-99	DIODE	DTZ5.1B	FB9634	1-414-445-11	FERRITE	0 $\mu$ H
D9601	8-719-976-99	DIODE	DTZ5.1B	FB9635	1-414-445-11	FERRITE	0 $\mu$ H
D9602	8-719-976-99	DIODE	DTZ5.1B	<b>IC</b>			
D9603	8-719-976-99	DIODE	DTZ5.1B	IC9600	8-759-830-08	IC	NJM2068V-TE2
D9604	8-719-081-97	DIODE	MMDL914T1	IC9601	8-759-278-58	IC	NJM4558V-TE2
D9606	8-719-081-97	DIODE	MMDL914T1	IC9602	8-759-278-58	IC	NJM4558V-TE2
D9607	8-719-081-97	DIODE	MMDL914T1	IC9603	8-759-641-26	IC	NJM2391DL1-33(TE1)
D9608	8-719-081-97	DIODE	MMDL914T1	IC9606	6-704-266-01	IC	CM0033AF
<b>FERRITE BEAD</b>				IC9607	8-753-207-87	IC	CXP86460-650Q
FB9600	1-414-445-11	FERRITE	0 $\mu$ H	IC9608	6-704-067-01	IC	M24128-BWMN6T(A)
FB9601	1-414-445-11	FERRITE	0 $\mu$ H	IC9609	8-759-352-91	IC	PST9143NL
FB9602	1-414-445-11	FERRITE	0 $\mu$ H	IC9610	8-759-830-08	IC	NJM2068V-TE2
FB9605	1-414-445-11	FERRITE	0 $\mu$ H	IC9611	8-759-830-08	IC	NJM2068V-TE2
FB9606	1-414-445-11	FERRITE	0 $\mu$ H	IC9612	8-759-830-08	IC	NJM2068V-TE2
FB9607	1-414-445-11	FERRITE	0 $\mu$ H	IC9613	8-759-700-65	IC	NJM79L05A
FB9608	1-414-445-11	FERRITE	0 $\mu$ H	<b>COIL</b>			
FB9609	1-414-445-11	FERRITE	0 $\mu$ H	L9600	1-469-552-21	INDUCTOR	3.3 $\mu$ H
FB9610	1-414-445-11	FERRITE	0 $\mu$ H	<b>TRANSISTOR</b>			
FB9611	1-414-445-11	FERRITE	0 $\mu$ H	Q9602	8-729-010-05	TRANSISTOR	MSB709-RT1
FB9612	1-414-445-11	FERRITE	0 $\mu$ H	Q9603	8-729-010-05	TRANSISTOR	MSB709-RT1
FB9613	1-414-445-11	FERRITE	0 $\mu$ H	Q9604	8-729-010-25	TRANSISTOR	MSD601-RT1
FB9614	1-414-445-11	FERRITE	0 $\mu$ H	Q9605	8-729-010-05	TRANSISTOR	MSB709-RT1
FB9616	1-414-445-11	FERRITE	0 $\mu$ H	Q9606	8-729-010-25	TRANSISTOR	MSD601-RT1
FB9617	1-414-445-11	FERRITE	0 $\mu$ H	Q9607	8-729-010-25	TRANSISTOR	MSD601-RT1
FB9618	1-414-445-11	FERRITE	0 $\mu$ H	Q9608	8-729-010-05	TRANSISTOR	MSB709-RT1
FB9619	1-414-445-11	FERRITE	0 $\mu$ H	Q9609	8-729-010-25	TRANSISTOR	MSD601-RT1
FB9620	1-414-445-11	FERRITE	0 $\mu$ H	<b>RESISTOR</b>			
FB9621	1-414-445-11	FERRITE	0 $\mu$ H	R9600	1-218-863-11	METAL CHIP	4.7K 0.50% 1/10W
FB9622	1-414-445-11	FERRITE	0 $\mu$ H	R9601	1-218-861-11	METAL CHIP	3.9K 0.50% 1/10W
FB9623	1-414-445-11	FERRITE	0 $\mu$ H	R9602	1-218-858-11	METAL CHIP	3K 0.50% 1/10W
FB9624	1-414-445-11	FERRITE	0 $\mu$ H	R9603	1-218-871-11	METAL CHIP	10K 0.50% 1/10W
FB9625	1-414-445-11	FERRITE	0 $\mu$ H	R9604	1-218-871-11	METAL CHIP	10K 0.50% 1/10W







REF.NO.	PART NO.	DESCRIPTION	VALUES			REF.NO.	PART NO.	DESCRIPTION	VALUES		
R9605	1-216-841-11	METAL CHIP	47K	5%	1/10W	R9658	1-216-821-11	METAL CHIP	1K	5%	1/10W
R9606	1-216-821-11	METAL CHIP	1K	5%	1/10W	R9659	1-216-821-11	METAL CHIP	1K	5%	1/10W
R9607	1-218-875-11	METAL CHIP	15K	0.50%	1/10W						
R9608	1-216-864-11	SHORT CHIP				R9661	1-216-833-11	METAL CHIP	10K	5%	1/10W
R9610	1-218-895-11	METAL CHIP	100K	0.50%	1/10W	R9662	1-216-821-11	METAL CHIP	1K	5%	1/10W
						R9664	1-216-820-11	METAL CHIP	820	5%	1/10W
R9611	1-218-877-11	METAL CHIP	18K	0.50%	1/10W	R9665	1-216-833-11	METAL CHIP	10K	5%	1/10W
R9612	1-218-847-11	METAL CHIP	1K	0.50%	1/10W	R9666	1-216-821-11	METAL CHIP	1K	5%	1/10W
R9613	1-216-837-11	METAL CHIP	22K	5%	1/10W						
R9620	1-216-821-11	METAL CHIP	1K	5%	1/10W	R9667	1-216-821-11	METAL CHIP	1K	5%	1/10W
R9621	1-216-821-11	METAL CHIP	1K	5%	1/10W	R9668	1-216-821-11	METAL CHIP	1K	5%	1/10W
						R9669	1-216-821-11	METAL CHIP	1K	5%	1/10W
R9622	1-216-821-11	METAL CHIP	1K	5%	1/10W	R9670	1-216-821-11	METAL CHIP	1K	5%	1/10W
R9623	1-216-821-11	METAL CHIP	1K	5%	1/10W	R9671	1-218-877-11	METAL CHIP	18K	0.50%	1/10W
R9626	1-216-809-11	METAL CHIP	100	5%	1/10W						
R9627	1-216-809-11	METAL CHIP	100	5%	1/10W	R9673	1-218-860-11	METAL CHIP	3.6K	0.50%	1/10W
R9628	1-216-809-11	METAL CHIP	100	5%	1/10W	R9674	1-218-877-11	METAL CHIP	18K	0.50%	1/10W
						R9676	1-218-877-11	METAL CHIP	18K	0.50%	1/10W
R9629	1-216-823-11	METAL CHIP	1.5K	5%	1/10W	R9677	1-216-833-11	METAL CHIP	10K	5%	1/10W
R9630	1-216-823-11	METAL CHIP	1.5K	5%	1/10W	R9678	1-218-871-11	METAL CHIP	10K	0.50%	1/10W
R9631	1-216-821-11	METAL CHIP	1K	5%	1/10W						
R9633	1-216-821-11	METAL CHIP	1K	5%	1/10W	R9679	1-216-833-11	METAL CHIP	10K	5%	1/10W
R9634	1-216-809-11	METAL CHIP	100	5%	1/10W	R9680	1-216-833-11	METAL CHIP	10K	5%	1/10W
						R9681	1-218-883-11	METAL CHIP	33K	0.50%	1/10W
R9635	1-216-809-11	METAL CHIP	100	5%	1/10W	R9682	1-218-883-11	METAL CHIP	33K	0.50%	1/10W
R9636	1-216-821-11	METAL CHIP	1K	5%	1/10W	R9683	1-218-883-11	METAL CHIP	33K	0.50%	1/10W
R9637	1-216-825-11	METAL CHIP	2.2K	5%	1/10W						
R9638	1-216-825-11	METAL CHIP	2.2K	5%	1/10W	R9684	1-218-883-11	METAL CHIP	33K	0.50%	1/10W
R9639	1-216-818-11	METAL CHIP	560	5%	1/10W	R9685	1-218-883-11	METAL CHIP	33K	0.50%	1/10W
						R9686	1-218-883-11	METAL CHIP	33K	0.50%	1/10W
R9640	1-216-825-11	METAL CHIP	2.2K	5%	1/10W	R9687	1-218-871-11	METAL CHIP	10K	0.50%	1/10W
R9641	1-216-818-11	METAL CHIP	560	5%	1/10W						
R9642	1-216-825-11	METAL CHIP	2.2K	5%	1/10W	R9688	1-218-871-11	METAL CHIP	10K	0.50%	1/10W
R9643	1-216-818-11	METAL CHIP	560	5%	1/10W	R9689	1-218-871-11	METAL CHIP	10K	0.50%	1/10W
R9644	1-216-833-11	METAL CHIP	10K	5%	1/10W	R9690	1-218-871-11	METAL CHIP	10K	0.50%	1/10W
						R9691	1-218-871-11	METAL CHIP	10K	0.50%	1/10W
R9645	1-218-855-11	METAL CHIP	2.2K	0.50%	1/10W	R9692	1-218-871-11	METAL CHIP	10K	0.50%	1/10W
R9646	1-216-809-11	METAL CHIP	100	5%	1/10W						
R9647	1-218-847-11	METAL CHIP	1K	0.50%	1/10W	R9693	1-218-868-11	METAL CHIP	7.5K	0.50%	1/10W
R9648	1-216-821-11	METAL CHIP	1K	5%	1/10W	R9695	1-218-860-11	METAL CHIP	3.6K	0.50%	1/10W
R9649	1-216-809-11	METAL CHIP	100	5%	1/10W	R9696	1-218-877-11	METAL CHIP	18K	0.50%	1/10W
						R9697	1-218-877-11	METAL CHIP	18K	0.50%	1/10W
R9650	1-216-809-11	METAL CHIP	100	5%	1/10W	R9698	1-218-868-11	METAL CHIP	7.5K	0.50%	1/10W
R9651	1-216-821-11	METAL CHIP	1K	5%	1/10W						
R9652	1-216-821-11	METAL CHIP	1K	5%	1/10W	R9701	1-218-863-11	METAL CHIP	4.7K	0.50%	1/10W
R9653	1-216-829-11	METAL CHIP	4.7K	5%	1/10W	R9702	1-218-863-11	METAL CHIP	4.7K	0.50%	1/10W
R9654	1-216-817-11	METAL CHIP	470	5%	1/10W	R9706	1-218-863-11	METAL CHIP	4.7K	0.50%	1/10W
						R9707	1-218-863-11	METAL CHIP	4.7K	0.50%	1/10W
R9655	1-216-821-11	METAL CHIP	1K	5%	1/10W	R9708	1-218-863-11	METAL CHIP	4.7K	0.50%	1/10W
R9656	1-216-817-11	METAL CHIP	470	5%	1/10W						
R9657	1-216-833-11	METAL CHIP	10K	5%	1/10W	R9711	1-216-833-11	METAL CHIP	10K	5%	1/10W
						R9712	1-216-833-11	METAL CHIP	10K	5%	1/10W

NOTE: The components identified by shading and  mark are critical for safety. Replace only with part number specified.

NOTE: Les composants identifiés par un trame et une marque  sont critiques pour la sécurité. Ne les remplacer que par une pièce portant le numéro spécifique.



REF.NO.	PART NO.	DESCRIPTION	VALUES	REF.NO.	PART NO.	DESCRIPTION	VALUES
R9713	1-218-887-11	METAL CHIP	47K 0.50% 1/10W	C5005	1-107-368-11	MYLAR	0.047µF 10% 200V
R9714	1-218-887-11	METAL CHIP	47K 0.50% 1/10W	C5006	1-162-131-11	CERAMIC	220pF 10% 2KV
R9715	1-218-887-11	METAL CHIP	47K 0.50% 1/10W	C5008	1-104-332-11	CERAMIC	470pF 10% 2KV
R9716	1-218-887-11	METAL CHIP	47K 0.50% 1/10W	C5009	1-162-318-11	CERAMIC	0.001µF 10% 500V
R9717	1-218-887-11	METAL CHIP	47K 0.50% 1/10W	C5010	1-104-987-11	MYLAR	0.001µF 5% 200V
R9718	1-218-887-11	METAL CHIP	47K 0.50% 1/10W	C5015	1-216-864-11	SHORT CHIP	
R9719	1-218-887-11	METAL CHIP	47K 0.50% 1/10W	C5016	1-107-826-11	CERAMIC CHIP	0.1µF 10% 16V
R9720	1-218-887-11	METAL CHIP	47K 0.50% 1/10W	C5017	1-104-987-11	MYLAR	0.001µF 5% 200V
R9721	1-218-841-11	METAL CHIP	560 0.50% 1/10W	C5019	1-162-966-11	CERAMIC CHIP	0.0022µF 10% 50V
R9722	1-218-859-11	METAL CHIP	3.3K 0.50% 1/10W	C5021	1-126-947-11	ELECT	47µF 20% 35V
R9723	1-218-841-11	METAL CHIP	560 0.50% 1/10W	 C5022	1-117-640-11	FILM	6800pF 3% 1.2KV
R9724	1-218-861-11	METAL CHIP	3.9K 0.50% 1/10W	C5103	1-126-934-11	ELECT	220µF 20% 16V
R9725	1-218-868-11	METAL CHIP	7.5K 0.50% 1/10W	C5104	1-126-941-11	ELECT	470µF 20% 25V
R9726	1-218-860-11	METAL CHIP	3.6K 0.50% 1/10W	C5105	1-164-227-11	CERAMIC CHIP	0.022µF 10% 25V
R9750	1-218-863-11	METAL CHIP	4.7K 0.50% 1/10W	C5106	1-164-227-11	CERAMIC CHIP	0.022µF 10% 25V
R9752	1-218-877-11	METAL CHIP	18K 0.50% 1/10W	C5107	1-136-171-00	FILM	0.33µF 5% 50V
R9753	1-215-866-11	METAL OXIDE	330 5% 1W	C5108	1-126-968-11	ELECT	100µF 20% 50V
<b>RESISTOR BRIDGE</b>				C5109	1-126-941-11	ELECT	470µF 20% 25V
RB9600	1-233-576-11	RES, CHIP NETWORK	100	C5110	1-162-318-11	CERAMIC	0.001µF 10% 500V
<b>VARISTOR</b>				C5111	1-162-964-11	CERAMIC CHIP	0.001µF 10% 50V
VD9600	1-804-499-21	VARISTOR, CHIP	(1608)	C5121	1-126-960-11	ELECT	1µF 20% 50V
VD9601	1-804-499-21	VARISTOR, CHIP	(1608)	C5201	1-137-150-51	FILM	0.01µF 5% 100V
VD9602	1-804-499-21	VARISTOR, CHIP	(1608)	C5202	1-162-970-11	CERAMIC CHIP	0.01µF 10% 25V
VD9603	1-804-499-21	VARISTOR, CHIP	(1608)	C5203	1-126-933-11	ELECT	100µF 20% 16V
<b>CRYSTAL</b>				C5204	1-107-648-91	ELECT	100µF 20% 200V
X9600	1-795-954-21	PIEZOELECTRIC OSCILLATOR		C5205	1-115-416-11	CERAMIC CHIP	0.001µF 5% 25V
				C5206	1-136-187-11	MYLAR	0.047µF 10% 250V
 * <b>A-1302-161-A D BOARD, COMPLETE</b>				C5207	1-165-727-31	ELECT	120µF 20% 16V
	3-710-578-01	COVER, VOLUME, 6 MOLD		C5208	1-162-970-11	CERAMIC CHIP	0.01µF 10% 25V
	4-382-854-01	SCREW (M3X8), P, SW (+)		C5209	1-162-924-11	CERAMIC CHIP	56pF 5% 50V
	4-382-854-21	SCREW (M3X14), P, SW (+)		C5210	1-162-968-11	CERAMIC CHIP	0.0047µF 10% 50V
The high-voltage leads associated with the FBT on the D board are not included and must be ordered separately. Order the following leads when requesting this D board:				C5211	1-107-826-11	CERAMIC CHIP	0.1µF 10% 16V
 1-779-095-51 LEAD ASSY, HIGH VOLTAGE				C5212	1-126-965-91	ELECT	22µF 20% 50V
 1-900-260-40 CONNECTOR ASSY, MV				C5213	1-126-965-91	ELECT	22µF 20% 50V
<b>CAPACITOR</b>				C5223	1-107-826-11	CERAMIC CHIP	0.1µF 10% 16V
C5001	1-162-966-11	CERAMIC CHIP	0.0022µF 10% 50V	C5228	1-102-228-00	CERAMIC	470pF 10% 500V
C5002	1-162-131-11	CERAMIC	220pF 10% 2KV	C5410	1-162-318-11	CERAMIC	0.001µF 10% 500V
				C5411	1-107-826-11	CERAMIC CHIP	0.1µF 10% 16V
				C5414	1-126-927-11	ELECT	2200µF 20% 10V
				C5416	1-126-927-11	ELECT	2200µF 20% 10V
				C5417	1-107-826-11	CERAMIC CHIP	0.1µF 10% 16V
				C5418	1-117-813-11	FILM	0.75µF 5% 250V
				C5419	1-107-649-11	ELECT	2.2µF 20% 250V





REF.NO.	PART NO.	DESCRIPTION	VALUES			REF.NO.	PART NO.	DESCRIPTION	VALUES		
C5423	1-126-947-11	ELECT	47μF	20%	35V	C6512	1-165-441-81	ELECT	33μF	20%	160V
C5550	1-104-666-11	ELECT	220μF	20%	25V	C6513	1-128-562-11	ELECT	47μF	20%	100V
C5551	1-104-665-11	ELECT	100μF	20%	25V	C6514	1-107-662-11	ELECT	22μF	20%	350V
C5552	1-126-964-11	ELECT	10μF	20%	50V	C6515	1-165-733-31	ELECT	100μF	20%	25V
C5553	1-126-933-11	ELECT	100μF	20%	16V	C6517	1-126-933-11	ELECT	100μF	20%	16V
C5554	1-115-349-51	CERAMIC	0.01μF		2KV	C6519	1-107-826-11	CERAMIC CHIP	0.1μF	10%	16V
C5555	1-126-965-91	ELECT	22μF	20%	50V	C6603	1-102-228-00	CERAMIC	470pF	10%	500V
C5556	1-126-965-91	ELECT	22μF	20%	50V	C6604	1-165-728-31	ELECT	330μF	20%	16V
C5557	1-162-974-11	CERAMIC CHIP	0.01μF		50V	C6607	1-165-729-31	ELECT	470μF	20%	16V
C5558	1-126-965-91	ELECT	22μF	20%	50V	C6611	1-104-665-11	ELECT	100μF	20%	25V
C5559	1-126-965-91	ELECT	22μF	20%	50V	C6613	1-104-665-11	ELECT	100μF	20%	25V
C5560	1-162-974-11	CERAMIC CHIP	0.01μF		50V	C6615	1-115-349-51	CERAMIC	0.01μF	2KV	
C5561	1-162-974-11	CERAMIC CHIP	0.01μF		50V	C6616	1-126-941-11	ELECT	470μF	20%	25V
C5562	1-126-965-91	ELECT	22μF	20%	50V	C6617	1-126-941-11	ELECT	470μF	20%	25V
C5563	1-162-974-11	CERAMIC CHIP	0.01μF		50V	C6618	1-102-228-00	CERAMIC	470pF	10%	500V
C5564	1-164-156-11	CERAMIC CHIP	0.1μF		25V	C6619	1-102-228-00	CERAMIC	470pF	10%	500V
C5565	1-137-378-11	MYLAR	0.22μF	5%	50V	C6620	1-162-318-11	CERAMIC	0.001μF	10%	500V
C5702	1-162-927-11	CERAMIC CHIP	100pF	5%	50V	C6700	1-164-227-11	CERAMIC CHIP	0.022μF	10%	25V
C5703	1-107-826-11	CERAMIC CHIP	0.1μF	10%	16V	C6707	1-162-318-11	CERAMIC	0.001μF	10%	500V
C6400	1-162-964-11	CERAMIC CHIP	0.001μF	10%	50V	C6803	1-104-665-11	ELECT	100μF	20%	25V
C6401	1-126-964-11	ELECT	10μF	20%	50V	C6804	1-126-964-11	ELECT	10μF	20%	50V
C6402	1-126-963-11	ELECT	4.7μF	20%	50V	C8001	1-126-964-11	ELECT	10μF	20%	50V
C6403	1-126-968-11	ELECT	100μF	20%	50V	C8002	1-126-964-11	ELECT	10μF	20%	50V
C6405	1-162-970-11	CERAMIC CHIP	0.01μF	10%	25V	C8003	1-162-970-11	CERAMIC CHIP	0.01μF	10%	25V
C6406	1-136-479-11	FILM	0.001μF	5%	100V	C8004	1-162-964-11	CERAMIC CHIP	0.001μF	10%	50V
C6407	1-130-495-00	MYLAR	0.1μF	5%	50V	C8006	1-126-960-11	ELECT	1μF	20%	50V
C6409	1-126-947-11	ELECT	47μF	20%	35V	C8007	1-162-964-11	CERAMIC CHIP	0.001μF	10%	50V
C6411	1-100-613-81	CERAMIC	470pF	5%	1KV	C8012	1-126-947-11	ELECT	47μF	20%	35V
C6412	1-100-613-81	CERAMIC	470pF	5%	1KV	C8015	1-126-947-11	ELECT	47μF	20%	35V
C6413	1-165-954-11	FILM	56000pF	3%	800V	C8016	1-130-495-00	MYLAR	0.1μF	5%	50V
C6414	1-117-228-71	MYLAR	2.2μF	10%	450V	C8017	1-126-965-91	ELECT	22μF	20%	50V
C6416	1-126-948-11	ELECT	100μF	20%	35V	C8018	1-126-965-91	ELECT	22μF	20%	50V
C6417	1-162-974-11	CERAMIC CHIP	0.01μF		50V	C8020	1-130-495-00	MYLAR	0.1μF	5%	50V
C6418	1-162-970-11	CERAMIC CHIP	0.01μF	10%	25V	C8021	1-162-968-11	CERAMIC CHIP	0.0047μF	10%	50V
C6419	1-126-941-11	ELECT	470μF	20%	25V	C8024	1-126-947-11	ELECT	47μF	20%	35V
C6420	1-126-941-11	ELECT	470μF	20%	25V	C8025	1-126-947-11	ELECT	47μF	20%	35V
C6500	1-126-952-11	ELECT	1000μF	20%	35V	C8027	1-130-495-00	MYLAR	0.1μF	5%	50V
C6501	1-126-952-11	ELECT	1000μF	20%	35V	C8028	1-162-966-11	CERAMIC CHIP	0.0022μF	10%	50V
C6503	1-131-970-11	ELECT	1500μF	20%	25V	C8030	1-162-970-11	CERAMIC CHIP	0.01μF	10%	25V
C6504	1-131-970-11	ELECT	1500μF	20%	25V	C8031	1-126-933-11	ELECT	100μF	20%	16V
C6505	1-131-970-11	ELECT	1500μF	20%	25V	C8032	1-117-160-51	FILM	680pF	2.00%	100V
C6509	1-162-964-11	CERAMIC CHIP	0.001μF	10%	50V	C8033	1-126-964-11	ELECT	10μF	20%	50V
						C8035	1-100-614-81	CERAMIC	330pF	5%	1KV
						C8036	1-100-614-81	CERAMIC	330pF	5%	1KV



REF.NO.	PART NO.	DESCRIPTION	VALUES	REF.NO.	PART NO.	DESCRIPTION	VALUES
C8037	1-165-954-11	FILM	56000pF 3% 800V	D5202	8-719-028-45	DIODE	D2L20U
C8040	1-126-969-11	ELECT	220μF 20% 50V	D5203	8-719-081-97	DIODE	MMDL914T1
C8041	1-130-495-00	MYLAR	0.1μF 5% 50V	D5204	8-719-081-97	DIODE	MMDL914T1
C8042	1-136-189-00	MYLAR	0.1μF 10% 250V	D5205	8-719-081-97	DIODE	MMDL914T1
C8045	1-130-471-00	MYLAR	0.001μF 5% 50V	D5206	8-719-081-97	DIODE	MMDL914T1
C8046	1-162-968-11	CERAMIC CHIP	0.0047μF 10% 50V	D5207	8-719-081-97	DIODE	MMDL914T1
C8048	1-130-495-00	MYLAR	0.1μF 5% 50V	D5209	8-719-066-11	DIODE	1PS184-115
C8063	1-135-945-22	FILM	10000pF 3% 800V	D5404	8-719-908-03	DIODE	GP08D
C8065	1-127-715-91	CERAMIC CHIP	0.22μF 10% 16V	D5520	8-719-081-97	DIODE	MMDL914T1
C8070	1-126-967-11	ELECT	47μF 20% 50V	D5521	8-719-081-97	DIODE	MMDL914T1
C8073	1-164-315-11	CERAMIC CHIP	470pF 5% 50V	D5701	8-719-070-57	DIODE	PDZ5.6B-115
C8074	1-162-970-11	CERAMIC CHIP	0.01μF 10% 25V	D6401	8-719-083-78	DIODE	10ERA60-TP
C8075	1-162-970-11	CERAMIC CHIP	0.01μF 10% 25V	D6406	8-719-082-03	DIODE	MM3Z15VT1
C8076	1-126-963-11	ELECT	4.7μF 20% 50V	D6407	8-719-082-03	DIODE	MM3Z15VT1
C8077	1-162-970-11	CERAMIC CHIP	0.01μF 10% 25V	D6410	6-500-567-21	DIODE	10ERB20-TB5
C8139	1-162-966-11	CERAMIC CHIP	0.0022μF 10% 50V	D6411	8-719-082-03	DIODE	MM3Z15VT1
<b>CONNECTOR</b>				D6413	8-719-082-03	DIODE	MM3Z15VT1
*	CN5003	1-564-508-11	PLUG, CONNECTOR 5P	D6415	8-719-082-03	DIODE	MM3Z15VT1
*	CN5004	1-779-890-11	CONNECTOR, BOARD TO BOARD 10P	D6502	8-719-060-88	DIODE	D4SBS6
*	CN5005	1-779-890-11	CONNECTOR, BOARD TO BOARD 10P	D6503	8-719-060-88	DIODE	D4SBS6
*	CN5006	1-779-890-11	CONNECTOR, BOARD TO BOARD 10P	D6508	8-719-062-40	DIODE	D4SBL20μF3
*	CN5007	1-779-890-11	CONNECTOR, BOARD TO BOARD 10P	D6509	8-719-052-90	DIODE	D1NL40-TA2
*	CN5008	1-564-509-11	PLUG, CONNECTOR 6P	D6510	8-719-052-37	DIODE	F10P04Q
*	CN5009	1-580-689-11	PIN, CONNECTOR (PC BOARD) 4P	D6511	6-500-567-21	DIODE	10ERB20-TB5
*	CN5010	1-580-689-11	PIN, CONNECTOR (PC BOARD) 4P	D6602	8-719-028-45	DIODE	D2L20U
*	CN5011	1-580-689-11	PIN, CONNECTOR (PC BOARD) 4P	D6604	8-719-075-66	DIODE	D5LC20U-4012
*	CN5013	1-564-506-11	PLUG, CONNECTOR 3P	D6606	8-719-028-72	DIODE	RGP02-17EL-6433
*	CN5014	1-564-506-11	PLUG, CONNECTOR 3P	D6607	8-719-028-45	DIODE	D2L20U
*	CN5015	1-564-506-11	PLUG, CONNECTOR 3P	D6608	8-719-028-45	DIODE	D2L20U
	CN5016	1-764-334-11	PIN, CONNECTOR(PCB)(V TYPE) 11P	D6800	8-719-150-92	DIODE	RD33EB3T
*	CN5017	1-564-509-11	PLUG, CONNECTOR 6P	D6803	8-719-081-97	DIODE	MMDL914T1
*	CN5019	1-564-506-11	PLUG, CONNECTOR 3P	D6804	6-500-654-01	DIODE	MM3Z3V0T1
*	CN5500	1-691-135-11	PIN, CONNECTOR (PC BOARD) 4P	D6805	8-719-081-97	DIODE	MMDL914T1
*	CN6400	1-580-843-11	PIN, CONNECTOR (POWER)	D8001	8-719-081-97	DIODE	MMDL914T1
	CN6401	1-764-101-11	PIN, CONNECTOR (PC BOARD) 2P	D8003	8-719-081-97	DIODE	MMDL914T1
	CN8001	1-695-915-11	TAB (CONTACT)	D8005	8-719-081-97	DIODE	MMDL914T1
<b>DIODE</b>				D8006	6-500-567-21	DIODE	10ERB20-TB5
D5003	8-719-081-97	DIODE	MMDL914T1	D8007	8-719-081-97	DIODE	MMDL914T1
D5005	8-719-081-97	DIODE	MMDL914T1	D8008	1-163-021-91	CERAMIC CHIP	0.01μF 10% 50V
D5101	8-719-036-94	DIODE	RD5.6SB-T1	D8009	8-719-072-69	DIODE	PDZ15B-115
D5102	8-719-908-03	DIODE	GP08D	D8010	8-719-083-78	DIODE	10ERA60-TP
D5201	8-719-110-39	DIODE	RD15ESB1	D8011	8-719-082-03	DIODE	MM3Z15VT1
				D8012	8-719-082-03	DIODE	MM3Z15VT1
				D8015	8-719-081-97	DIODE	MMDL914T1

NOTE: The components identified by shading and  $\triangle$  mark are critical for safety. Replace only with part number specified.

NOTE: Les composants identifiés par un trame et une marque  $\triangle$  sont critiques pour la sécurité. Ne les remplacer que par une pièce portant le numéro spécifique.



REF.NO.	PART NO.	DESCRIPTION	VALUES	REF.NO.	PART NO.	DESCRIPTION	VALUES
$\triangle$ D8022	8-719-063-73	DIODE	D1NL20U-TR	$\triangle$ IC8002	6-703-355-01	IC	MCZ3001DA
D8023	8-719-070-10	DIODE	NNCD5.1A-T1	$\triangle$ IC8004	8-759-701-01	IC	NJM2904M
D8024	8-719-056-82	DIODE	UDZ-TE-17-6.2B	$\triangle$ IC8005	8-759-586-17	IC	TL1431CZ-AP
D8026	8-719-081-97	DIODE	MMDL914T1	IC8006	8-759-700-07	IC	NJM2903M
D8027	6-500-654-01	DIODE	MM3Z3V0T1	$\triangle$ IC8104	8-759-586-17	IC	TL1431CZ-AP
D8030	8-719-056-93	DIODE	UDZ-TE-17-18B	<b>CHIP CONDUCTOR</b>			
D8034	8-719-056-83	DIODE	UDZ-TE-17-6.8B	JR1001	1-216-864-11	SHORT CHIP	
D8038	8-719-082-03	DIODE	MM3Z15VT1	JR1002	1-216-864-11	SHORT CHIP	
D8039	8-719-082-03	DIODE	MM3Z15VT1	JR1003	1-216-864-11	SHORT CHIP	
D8041	8-719-082-03	DIODE	MM3Z15VT1	JR1004	1-216-864-11	SHORT CHIP	
D8140	8-719-404-50	DIODE	MA111-TX	JR1005	1-216-864-11	SHORT CHIP	
<b>FERRITE BEAD</b>				JR1006	1-216-864-11	SHORT CHIP	
FB5201	1-469-578-11	FERRITE	1.1 $\mu$ H	JR1007	1-216-864-11	SHORT CHIP	
FB5203	1-469-127-21	FERRITE	0 $\mu$ H	JR1008	1-216-864-11	SHORT CHIP	
FB5205	1-469-578-11	FERRITE	1.1 $\mu$ H	JR1009	1-216-864-11	SHORT CHIP	
FB5206	1-469-578-11	FERRITE	1.1 $\mu$ H	JR1010	1-216-864-11	SHORT CHIP	
FB6400	1-469-579-11	FERRITE	0.45 $\mu$ H	JR1011	1-216-864-11	SHORT CHIP	
FB6401	1-469-579-11	FERRITE	0.45 $\mu$ H	JR1013	1-216-864-11	SHORT CHIP	
FB6402	1-469-579-11	FERRITE	0.45 $\mu$ H	JR1014	1-216-864-11	SHORT CHIP	
FB6403	1-469-579-11	FERRITE	0.45 $\mu$ H	JR1015	1-216-864-11	SHORT CHIP	
FB6405	1-469-579-11	FERRITE	0.45 $\mu$ H	JR1017	1-216-864-11	SHORT CHIP	
FB6406	1-469-579-11	FERRITE	0.45 $\mu$ H	JR1018	1-216-864-11	SHORT CHIP	
FB6407	1-469-579-11	FERRITE	0.45 $\mu$ H	JR1019	1-216-864-11	SHORT CHIP	
FB6408	1-469-579-11	FERRITE	0.45 $\mu$ H	JR1020	1-216-864-11	SHORT CHIP	
FB6500	1-469-579-11	FERRITE	0.45 $\mu$ H	JR1021	1-216-864-11	SHORT CHIP	
FB6501	1-469-579-11	FERRITE	0.45 $\mu$ H	JR1022	1-216-864-11	SHORT CHIP	
FB6506	1-469-578-11	FERRITE	1.1 $\mu$ H	JR1023	1-216-864-11	SHORT CHIP	
FB6507	1-469-578-11	FERRITE	1.1 $\mu$ H	JR1024	1-216-864-11	SHORT CHIP	
FB6508	1-469-578-11	FERRITE	1.1 $\mu$ H	JR1025	1-216-864-11	SHORT CHIP	
FB8001	1-469-579-11	FERRITE	0.45 $\mu$ H	JR1026	1-216-864-11	SHORT CHIP	
FB8002	1-469-579-11	FERRITE	0.45 $\mu$ H	JR1028	1-216-864-11	SHORT CHIP	
FB8003	1-469-579-11	FERRITE	0.45 $\mu$ H	JR1029	1-216-864-11	SHORT CHIP	
<b>IC</b>				JR1031	1-216-864-11	SHORT CHIP	
IC5101	8-759-593-33	IC	LA78045	JR1032	1-216-864-11	SHORT CHIP	
IC5201	8-759-585-82	IC	BA9759F-E2	JR1033	1-216-864-11	SHORT CHIP	
IC5402	8-759-803-42	IC	LA6500-FA	JR1034	1-216-864-11	SHORT CHIP	
IC5403	8-759-701-01	IC	NJM2904M	JR1036	1-216-864-11	SHORT CHIP	
IC6400	6-703-355-01	IC	MCZ3001DA	JR5401	1-216-864-11	SHORT CHIP	
IC6501	8-759-518-68	IC	PQ12RF21	JR5403	1-216-864-11	SHORT CHIP	
IC6503	6-704-264-01	IC	EK1135	JR6501	1-216-864-11	SHORT CHIP	
IC6602	8-759-665-67	IC	PQ30RV2B	JR6509	1-216-864-11	SHORT CHIP	
IC6801	8-749-921-86	IC	SE-140N	JR6602	1-216-864-11	SHORT CHIP	
$\triangle$ IC8001	8-759-700-07	IC	NJM2903M	JR6702	1-216-864-11	SHORT CHIP	

NOTE: The components identified by shading and  $\triangle$  mark are critical for safety. Replace only with part number specified.

NOTE: Les composants identifiés par un trame et une marque  $\triangle$  sont critiques pour la sécurité. Ne les remplacer que par une pièce portant le numéro spécifique.



REF.NO.	PART NO.	DESCRIPTION	VALUES	REF.NO.	PART NO.	DESCRIPTION	VALUES
<b>COIL</b>							
L5101	1-406-665-11	INDUCTOR	100 $\mu$ H	Q5524	8-729-207-89	TRANSISTOR	2SA1358-Y
L5202	1-414-189-31	INDUCTOR	100 $\mu$ H	Q5525	8-729-010-25	TRANSISTOR	MSD601-RT1
L5403	1-456-109-11	COIL,HORIZONTAL LINEARITY(HLC)		Q5526	8-729-010-05	TRANSISTOR	MSB709-RT1
L5405	1-412-552-11	INDUCTOR	2.2MH	Q5527	8-729-010-25	TRANSISTOR	MSD601-RT1
L5520	1-412-525-31	INDUCTOR	10 $\mu$ H	Q5528	8-729-010-25	TRANSISTOR	MSD601-RT1
L5521	1-412-525-31	INDUCTOR	10 $\mu$ H	Q5701	8-729-010-25	TRANSISTOR	MSD601-RT1
L5522	1-414-187-11	INDUCTOR	47 $\mu$ H	Q5702	8-729-010-05	TRANSISTOR	MSB709-RT1
L5523	1-414-187-11	INDUCTOR	47 $\mu$ H	Q5703	8-729-010-05	TRANSISTOR	MSB709-RT1
L6400	1-414-187-11	INDUCTOR	47 $\mu$ H	Q6400	6-550-526-11	TRANSISTOR	2SK2842(LBS2SONY)
L6501	1-412-525-31	INDUCTOR	10 $\mu$ H	Q6401	6-550-526-11	TRANSISTOR	2SK2842(LBS2SONY)
L6502	1-412-525-31	INDUCTOR	10 $\mu$ H	Q6402	8-729-421-22	TRANSISTOR	UN2211
L6503	1-412-525-31	INDUCTOR	10 $\mu$ H	Q6403	8-729-421-22	TRANSISTOR	UN2211
L6505	1-412-525-31	INDUCTOR	10 $\mu$ H	Q6404	8-729-421-22	TRANSISTOR	UN2211
L6508	1-412-525-31	INDUCTOR	10 $\mu$ H	Q6802	8-729-010-05	TRANSISTOR	MSB709-RT1
L8002	1-428-950-31	INDUCTOR	125 $\mu$ H	Q6803	8-729-019-57	TRANSISTOR	2SA1208S-TP
<b>PHOTO COUPLER</b>							
$\triangle$ PH6401	8-749-016-81	PHOTO COUPLER	PC123Y22	$\triangle$ Q8007	8-729-010-25	TRANSISTOR	MSD601-RT1
$\triangle$ PH6700	8-749-016-81	PHOTO COUPLER	PC123Y22	$\triangle$ Q8008	8-729-010-25	TRANSISTOR	MSD601-RT1
PH8001	8-749-016-81	PHOTO COUPLER	PC123Y22	Q8009	8-729-010-25	TRANSISTOR	MSD601-RT1
$\triangle$ PH8003	8-749-016-81	PHOTO COUPLER	PC123Y22	Q8011	8-729-010-05	TRANSISTOR	MSB709-RT1
PH8004	8-749-016-81	PHOTO COUPLER	PC123Y22	Q8013	6-550-526-11	TRANSISTOR	2SK2842(LBS2SONY)
<b>IC LINK</b>							
$\triangle$ PS5401	1-532-685-00	IC LINK	0.8A 50V	Q8014	6-550-526-11	TRANSISTOR	2SK2842(LBS2SONY)
<b>TRANSISTOR</b>							
Q5001	6-550-077-01	TRANSISTOR	2SC5778-RB	Q8021	8-729-010-05	TRANSISTOR	MSB709-RT1
Q5004	8-729-010-25	TRANSISTOR	MSD601-RT1	Q8028	8-729-421-22	TRANSISTOR	UN2211
Q5005	8-729-010-25	TRANSISTOR	MSD601-RT1	Q8034	8-729-421-22	TRANSISTOR	UN2211
Q5006	8-729-038-83	TRANSISTOR	2SK2251-01-F19	Q8035	8-729-010-05	TRANSISTOR	MSB709-RT1
Q5008	8-729-010-25	TRANSISTOR	MSD601-RT1	<b>RESISTOR</b>			
Q5009	8-729-010-05	TRANSISTOR	MSB709-RT1	R5001	1-243-619-71	METAL OXIDE	12K 5% 3W
Q5101	8-729-010-25	TRANSISTOR	MSD601-RT1	R5002	1-243-619-71	METAL OXIDE	12K 5% 3W
Q5102	8-729-010-25	TRANSISTOR	MSD601-RT1	R5003	1-215-873-00	METAL OXIDE	4.7K 5% 1W
Q5103	8-729-010-25	TRANSISTOR	MSD601-RT1	R5010	1-243-801-71	METAL OXIDE	0.22 5% 1W
Q5201	6-550-153-11	TRANSISTOR	FQpF12P20YDTU	R5019	1-216-829-11	METAL CHIP	4.7K 5% 1/10W
Q5202	8-729-010-25	TRANSISTOR	MSD601-RT1	R5020	1-216-833-11	METAL CHIP	10K 5% 1/10W
Q5203	8-729-010-25	TRANSISTOR	MSD601-RT1	R5021	1-216-809-11	METAL CHIP	100 5% 1/10W
Q5406	8-729-048-47	TRANSISTOR	2SC2688(5)-LK	R5023	1-216-833-11	METAL CHIP	10K 5% 1/10W
Q5520	6-550-659-01	TRANSISTOR	2SC4634LS-YB11	R5024	1-216-833-11	METAL CHIP	10K 5% 1/10W
Q5521	8-729-010-05	TRANSISTOR	MSB709-RT1	R5025	1-216-809-11	METAL CHIP	100 5% 1/10W
Q5522	8-729-046-80	TRANSISTOR	2SC4634LS-CB11	R5028	1-216-821-11	METAL CHIP	1K 5% 1/10W
Q5523	8-729-207-82	TRANSISTOR	2SC3421-Y	R5029	1-216-833-11	METAL CHIP	10K 5% 1/10W
				R5031	1-249-393-11	CARBON	10 5% 1/4W
				R5032	1-216-841-11	METAL CHIP	47K 5% 1/10W
				R5033	1-249-401-11	CARBON	47 5% 1/4W















REF.NO.	PART NO.	DESCRIPTION	VALUES			REF.NO.	PART NO.	DESCRIPTION	VALUES		
R5101	1-216-845-11	METAL CHIP	100K	5%	1/10W	R5247	1-216-829-11	METAL CHIP	4.7K	5%	1/10W
R5102	1-216-841-11	METAL CHIP	47K	5%	1/10W	R5249	1-216-837-11	METAL CHIP	22K	5%	1/10W
R5103	1-216-833-11	METAL CHIP	10K	5%	1/10W						
R5104	1-216-833-11	METAL CHIP	10K	5%	1/10W	R5250	1-218-871-11	METAL CHIP	10K	0.50%	1/10W
R5106	1-216-833-11	METAL CHIP	10K	5%	1/10W	R5251	1-218-895-11	METAL CHIP	100K	0.50%	1/10W
						R5252	1-218-895-11	METAL CHIP	100K	0.50%	1/10W
R5107	1-218-865-11	METAL CHIP	5.6K	0.50%	1/10W	R5415	1-243-693-71	METAL OXIDE	270	5%	1W
R5108	1-218-865-11	METAL CHIP	5.6K	0.50%	1/10W	R5417	1-216-821-11	METAL CHIP	1K	5%	1/10W
R5109	1-216-833-11	METAL CHIP	10K	5%	1/10W						
R5110	1-216-833-11	METAL CHIP	10K	5%	1/10W	R5421	1-216-821-11	METAL CHIP	1K	5%	1/10W
R5111	1-249-383-11	CARBON	1.5	5%	1/4W	R5424	1-243-521-71	METAL OXIDE	15	5%	3W
						R5427	1-243-713-71	METAL OXIDE	10K	5%	1W
R5112	1-218-865-11	METAL CHIP	5.6K	0.50%	1/10W	R5430	1-216-833-11	METAL CHIP	10K	5%	1/10W
R5113	1-218-865-11	METAL CHIP	5.6K	0.50%	1/10W	R5432	1-216-809-11	METAL CHIP	100	5%	1/10W
R5115	1-218-867-11	METAL CHIP	6.8K	0.50%	1/10W						
R5116	1-218-867-11	METAL CHIP	6.8K	0.50%	1/10W	R5433	1-216-833-11	METAL CHIP	10K	5%	1/10W
R5117	1-214-800-11	METAL	2.2	1%	1/2W	R5434	1-216-821-11	METAL CHIP	1K	5%	1/10W
						R5435	1-260-314-11	CARBON	68	5%	1/2W
R5118	1-214-800-11	METAL	2.2	1%	1/2W	R5571	1-249-377-11	CARBON	0.47	5%	1/4W
R5119	1-243-572-71	METAL OXIDE	470	5%	2W	R5575	1-260-131-11	CARBON	470K	5%	1/2W
R5120	1-243-572-71	METAL OXIDE	470	5%	2W						
R5121	1-249-414-11	CARBON	560	5%	1/4W	R5576	1-216-833-11	METAL CHIP	10K	5%	1/10W
R5126	1-218-917-11	METAL CHIP	820K	0.50%	1/10W	R5577	1-216-829-11	METAL CHIP	4.7K	5%	1/10W
						R5578	1-216-809-11	METAL CHIP	100	5%	1/10W
R5127	1-216-857-11	METAL CHIP	1M	5%	1/10W	R5579	1-216-833-11	METAL CHIP	10K	5%	1/10W
R5201	1-218-879-11	METAL CHIP	22K	0.50%	1/10W	R5580	1-216-833-11	METAL CHIP	10K	5%	1/10W
R5202	1-218-883-11	METAL CHIP	33K	0.50%	1/10W						
R5206	1-249-425-11	CARBON	4.7K	5%	1/4W	R5581	1-216-833-11	METAL CHIP	10K	5%	1/10W
R5207	1-218-889-11	METAL CHIP	56K	0.50%	1/10W	R5582	1-218-863-11	METAL CHIP	4.7K	0.50%	1/10W
						R5583	1-260-107-11	CARBON	4.7K	5%	1/2W
R5208	1-249-409-11	CARBON	220	5%	1/4W	R5584	1-243-598-71	METAL OXIDE	68K	5%	2W
R5209	1-218-895-11	METAL CHIP	100K	0.50%	1/10W	R5585	1-243-598-71	METAL OXIDE	68K	5%	2W
R5210	1-216-845-11	METAL CHIP	100K	5%	1/10W						
R5211	1-218-895-11	METAL CHIP	100K	0.50%	1/10W	R5586	1-218-854-11	METAL CHIP	2K	0.50%	1/10W
R5212	1-218-871-11	METAL CHIP	10K	0.50%	1/10W	R5587	1-260-328-11	CARBON	1K	5%	1/2W
						R5588	1-216-353-00	METAL OXIDE	2.2	5%	1W
R5213	1-216-845-11	METAL CHIP	100K	5%	1/10W	R5589	1-249-385-11	CARBON	2.2	5%	1/4W
R5214	1-216-845-11	METAL CHIP	100K	5%	1/10W	R5590	1-249-385-11	CARBON	2.2	5%	1/4W
R5215	1-216-845-11	METAL CHIP	100K	5%	1/10W						
R5216	1-216-833-11	METAL CHIP	10K	5%	1/10W	R5591	1-216-801-11	METAL CHIP	22	5%	1/10W
R5217	1-218-871-11	METAL CHIP	10K	0.50%	1/10W	R5592	1-216-801-11	METAL CHIP	22	5%	1/10W
						R5593	1-216-816-11	METAL CHIP	390	5%	1/10W
R5221	1-218-895-11	METAL CHIP	100K	0.50%	1/10W	R5594	1-216-828-11	METAL CHIP	3.9K	5%	1/10W
R5223	1-218-895-11	METAL CHIP	100K	0.50%	1/10W	R5595	1-216-813-11	METAL CHIP	220	5%	1/10W
R5225	1-216-864-11	SHORT CHIP									
R5231	1-216-864-11	SHORT CHIP				R5596	1-216-824-11	METAL CHIP	1.8K	5%	1/10W
R5237	1-216-864-11	SHORT CHIP				R5597	1-216-819-11	METAL CHIP	680	5%	1/10W
						R5598	1-215-438-00	METAL	5.1K	1%	1/4W
R5241	1-216-821-11	METAL CHIP	1K	5%	1/10W	R5599	1-249-377-11	CARBON	0.47	5%	1/4W
R5243	1-216-843-11	METAL CHIP	68K	5%	1/10W	R5701	1-260-107-11	CARBON	4.7K	5%	1/2W
R5245	1-216-833-11	METAL CHIP	10K	5%	1/10W						

NOTE: The components identified by shading and  mark are critical for safety. Replace only with part number specified.

NOTE: Les composants identifiés par un trame et une marque  sont critiques pour la sécurité. Ne les remplacer que par une pièce portant le numéro spécifique.























REF.NO.	PART NO.	DESCRIPTION	VALUES			REF.NO.	PART NO.	DESCRIPTION	VALUES		
R5702	1-216-864-11	SHORT CHIP				R6702	1-216-821-11	METAL CHIP	1K	5%	1/10W
R5704	1-216-828-11	METAL CHIP	3.9K	5%	1/10W	R6703	1-218-484-11	METAL CHIP	750	5%	1/10W
R5706	1-216-833-11	METAL CHIP	10K	5%	1/10W	R6704	1-218-484-11	METAL CHIP	750	5%	1/10W
R5708	1-216-841-11	METAL CHIP	47K	5%	1/10W	R6705	1-216-833-11	METAL CHIP	10K	5%	1/10W
R5709	1-216-813-11	METAL CHIP	220	5%	1/10W	R6708	1-216-864-11	SHORT CHIP			
R5710	1-249-377-11	CARBON	0.47	5%	1/4W	R6809	1-249-405-11	CARBON	100	5%	1/4W
R6402	1-218-870-11	METAL CHIP	9.1K	0.50%	1/10W	R6810	1-216-821-11	METAL CHIP	1K	5%	1/10W
R6405	1-218-823-11	METAL CHIP	100	0.50%	1/10W	R6811	1-216-825-11	METAL CHIP	2.2K	5%	1/10W
R6406	1-245-478-21	METAL	470K	1%	1/4W	R6812	1-243-511-71	METAL OXIDE	2.2	5%	3W
R6407	1-218-875-11	METAL CHIP	15K	0.50%	1/10W	R6813	1-216-833-11	METAL CHIP	10K	5%	1/10W
R6409	1-218-830-11	METAL CHIP	200	0.50%	1/10W	R6814	1-218-855-11	METAL CHIP	2.2K	0.50%	1/10W
R6411	1-249-393-11	CARBON	10	5%	1/4W	R6815	1-216-837-11	METAL CHIP	22K	5%	1/10W
R6412	1-249-393-11	CARBON	10	5%	1/4W	R6816	1-216-846-11	METAL CHIP	120K	5%	1/10W
R6413	1-216-833-11	METAL CHIP	10K	5%	1/10W	R6817	1-216-846-11	METAL CHIP	120K	5%	1/10W
R6414	1-216-833-11	METAL CHIP	10K	5%	1/10W	R6818	1-245-471-21	METAL	240K	1%	1/4W
R6417	1-245-315-71	METAL OXIDE	0.1	5%	2W	R6821	1-245-471-21	METAL	240K	1%	1/4W
R6418	1-245-315-71	METAL OXIDE	0.1	5%	2W	R8001	1-219-512-11	METAL	2.2M	5%	1/2W
R6420	1-249-393-11	CARBON	10	5%	1/4W	R8002	1-219-512-11	METAL	2.2M	5%	1/2W
R6421	1-202-933-61	FUSIBLE	0.1	10%	1/2W	R8003	1-216-837-11	METAL CHIP	22K	5%	1/10W
R6422	1-249-377-11	CARBON	0.47	5%	1/4W	R8004	1-216-829-11	METAL CHIP	4.7K	5%	1/10W
R6423	1-216-845-11	METAL CHIP	100K	5%	1/10W	R8005	1-216-837-11	METAL CHIP	22K	5%	1/10W
R6424	1-249-433-11	CARBON	22K	5%	1/4W	 R8008	1-218-877-11	METAL CHIP	18K	0.50%	1/10W
R6425	1-216-821-11	METAL CHIP	1K	5%	1/10W	R8010	1-218-484-11	METAL CHIP	750	5%	1/10W
R6426	1-216-833-11	METAL CHIP	10K	5%	1/10W	R8011	1-216-849-11	METAL CHIP	220K	5%	1/10W
R6427	1-216-857-11	METAL CHIP	1M	5%	1/10W	 R8012	1-247-828-11	CARBON	750	5%	1/4W
R6428	1-216-857-11	METAL CHIP	1M	5%	1/10W	R8013	1-216-833-11	METAL CHIP	10K	5%	1/10W
R6429	1-245-478-21	METAL	470K	1%	1/4W	 R8014	1-218-847-11	METAL CHIP	1K	0.50%	1/10W
R6500	1-216-833-11	METAL CHIP	10K	5%	1/10W	 R8015	1-218-855-11	METAL CHIP	2.2K	0.50%	1/10W
R6501	1-216-833-11	METAL CHIP	10K	5%	1/10W	 R8016	1-247-843-11	CARBON	3.3K	5%	1/4W
R6503	1-243-588-71	METAL OXIDE	10K	5%	2W	 R8017	1-218-855-11	METAL CHIP	2.2K	0.50%	1/10W
R6504	1-260-298-51	CARBON	3.3	5%	1/2W	 R8019	1-218-875-11	METAL CHIP	15K	0.50%	1/10W
R6505	1-249-389-11	CARBON	4.7	5%	1/4W	R8020	1-216-833-11	METAL CHIP	10K	5%	1/10W
R6590	1-249-409-11	CARBON	220	5%	1/4W	R8022	1-216-839-11	METAL CHIP	33K	5%	1/10W
R6602	1-249-380-11	CARBON	0.82	5%	1/4W	R8024	1-216-839-11	METAL CHIP	33K	5%	1/10W
R6604	1-249-377-11	CARBON	0.47	5%	1/4W	R8025	1-216-821-11	METAL CHIP	1K	5%	1/10W
R6605	1-249-377-11	CARBON	0.47	5%	1/4W	R8026	1-218-853-11	METAL CHIP	1.8K	0.50%	1/10W
R6610	1-218-857-11	METAL CHIP	2.7K	0.50%	1/10W	 R8027	1-218-891-11	METAL CHIP	68K	0.50%	1/10W
R6611	1-218-843-11	METAL CHIP	680	0.50%	1/10W	R8028	1-218-865-11	METAL CHIP	5.6K	0.50%	1/10W
R6612	1-249-377-11	CARBON	0.47	5%	1/4W	 R8029	1-218-891-11	METAL CHIP	68K	0.50%	1/10W
R6613	1-260-288-11	CARBON	0.47	5%	1/2W	 R8030	1-218-895-11	METAL CHIP	100K	0.50%	1/10W
R6614	1-260-288-11	CARBON	0.47	5%	1/2W	 R8031	1-218-895-11	METAL CHIP	100K	0.50%	1/10W
R6700	1-216-817-11	METAL CHIP	470	5%	1/10W	R8032	1-216-817-11	METAL CHIP	470	5%	1/10W
						R8033	1-216-841-11	METAL CHIP	47K	5%	1/10W
						 R8035	1-218-861-11	METAL CHIP	3.9K	0.50%	1/10W

**NOTE:** The components identified by shading and  mark are critical for safety. Replace only with part number specified.

A component identified by this  symbol indicates that it has been carefully factory-selected to satisfy regulations regarding X-ray radiation. Should replacement be required, replace only with the value originally used.



REF.NO.	PART NO.	DESCRIPTION	VALUES			REF.NO.	PART NO.	DESCRIPTION	VALUES				
	R8036	1-215-419-00	METAL	820	1%	1/4W	R8137	1-216-821-11	METAL CHIP	1K	5%	1/10W	
	R8037	1-215-447-00	METAL	12K	1%	1/4W	R8138	1-216-857-11	METAL CHIP	1M	5%	1/10W	
	R8038	1-215-447-00	METAL	12K	1%	1/4W	R8144	1-216-849-11	METAL CHIP	220K	5%	1/10W	
	R8039	1-215-447-00	METAL	12K	1%	1/4W	R8145	1-216-841-11	METAL CHIP	47K	5%	1/10W	
	R8040	1-215-419-00	METAL	820	1%	1/4W	R8146	1-216-821-11	METAL CHIP	1K	5%	1/10W	
	R8041	1-216-864-11	SHORT CHIP				R8158	1-216-809-11	METAL CHIP	100	5%	1/10W	
	R8043	1-215-447-00	METAL	12K	1%	1/4W	R8159	1-216-835-11	METAL CHIP	15K	5%	1/10W	
	R8046	1-218-855-11	METAL CHIP	2.2K	0.50%	1/10W	R8160	1-216-853-11	METAL CHIP	470K	5%	1/10W	
	R8049	1-218-823-11	METAL CHIP	100	0.50%	1/10W	R8161	1-216-833-11	METAL CHIP	10K	5%	1/10W	
	R8050	1-211-979-11	METAL CHIP	27	0.50%	1/10W		R8165	1-218-897-11	METAL CHIP	120K	0.50%	1/10W
	R8051	1-202-933-61	FUSIBLE	0.1	10%	1/2W	R8166	1-216-809-11	METAL CHIP	100	5%	1/10W	
	R8052	1-218-893-11	METAL CHIP	82K	0.50%	1/10W	<b>VARIABLE RESISTOR</b>						
	R8054	1-245-478-21	METAL	470K	1%	1/4W		 RV8002	1-225-627-91	RES, VAR, ADJ, CERMET	2K		
	R8055	1-245-478-21	METAL	470K	1%	1/4W	<b>SPARK GAP</b>						
	R8056	1-218-870-11	METAL CHIP	9.1K	0.50%	1/10W	SG5500	1-519-466-11	GAP, SPARK				
	R8057	1-218-874-11	METAL CHIP	13K	0.50%	1/10W		SG8002	1-517-499-21	GAP, SPARK			
	R8058	1-249-393-11	CARBON	10	5%	1/4W	<b>TRANSFORMER</b>						
	R8059	1-216-864-11	SHORT CHIP				T5001	1-437-739-11	TRANSFORMER, FERRITE (HDT)				
	R8060	1-218-839-11	METAL CHIP	470	0.50%	1/10W	T5200	1-439-824-21	TRANSFORMER, HORIZONTAL OUTPUT				
	R8061	1-249-393-11	CARBON	10	5%	1/4W	T5500	1-437-708-11	TRANSFORMER, FERRITE (DFT)				
	R8062	1-216-833-11	METAL CHIP	10K	5%	1/10W		T6400	1-439-821-11	TRANSFORMER, CONVERTER (PIT)			
	R8063	1-216-833-11	METAL CHIP	10K	5%	1/10W		T8001	1-453-450-11	FBT ASSY NX-6030/M3A4			
	R8066	1-216-821-11	METAL CHIP	1K	5%	1/10W							
	R8069	1-249-425-11	CARBON	4.7K	5%	1/4W	* <b>A-1302-352-A UD BOARD, COMPLETE</b>						
	R8070	1-245-315-71	METAL OXIDE	0.1	5%	2W	4-382-854-51 SCREW (M3X6), P, SW (+)						
	R8072	1-249-377-11	CARBON	0.47	5%	1/4W	4-635-966-01 SCREW (HEX)						
	R8073	1-216-857-11	METAL CHIP	1M	5%	1/10W	<b>CAPACITOR</b>						
	R8074	1-216-857-11	METAL CHIP	1M	5%	1/10W	C7001	1-126-395-11	ELECT CHIP	22µF	20%	16V	
	R8076	1-249-411-11	CARBON	330	5%	1/4W	C7002	1-162-917-11	CERAMIC CHIP	15pF	5%	50V	
	R8078	1-218-895-11	METAL CHIP	100K	0.50%	1/10W	C7004	1-162-970-11	CERAMIC CHIP	0.01µF	10%	25V	
	R8079	1-215-449-00	METAL	15K	1%	1/4W	C7005	1-162-970-11	CERAMIC CHIP	0.01µF	10%	25V	
	R8082	1-216-863-11	METAL CHIP	3.3M	5%	1/10W	C7006	1-124-779-00	ELECT CHIP	10µF	20%	16V	
	R8085	1-219-749-91	METAL	10K	5%	1/2W	C7007	1-162-917-11	CERAMIC CHIP	15pF	5%	50V	
	R8086	1-219-750-91	METAL	22K	5%	1/2W	C7008	1-162-970-11	CERAMIC CHIP	0.01µF	10%	25V	
	R8088	1-216-833-11	METAL CHIP	10K	5%	1/10W	C7010	1-162-970-11	CERAMIC CHIP	0.01µF	10%	25V	
	R8089	1-216-845-11	METAL CHIP	100K	5%	1/10W	C7011	1-162-970-11	CERAMIC CHIP	0.01µF	10%	25V	
	R8090	1-216-833-11	METAL CHIP	10K	5%	1/10W	C7012	1-124-779-00	ELECT CHIP	10µF	20%	16V	
	R8092	1-249-377-11	CARBON	0.47	5%	1/4W	C7013	1-162-970-11	CERAMIC CHIP	0.01µF	10%	25V	
	R8093	1-216-833-11	METAL CHIP	10K	5%	1/10W	C7014	1-162-970-11	CERAMIC CHIP	0.01µF	10%	25V	
	R8096	1-249-413-11	CARBON	470	5%	1/4W							
	R8097	1-216-797-11	METAL CHIP	10	5%	1/10W							
	R8099	1-218-839-11	METAL CHIP	470	0.50%	1/10W							
	R8135	1-216-833-11	METAL CHIP	10K	5%	1/10W							
	R8136	1-216-827-11	METAL CHIP	3.3K	5%	1/10W							



REF.NO.	PART NO.	DESCRIPTION	VALUES			REF.NO.	PART NO.	DESCRIPTION	VALUES		
C7015	1-162-970-11	CERAMIC CHIP	0.01µF	10%	25V	C7060	1-164-156-11	CERAMIC CHIP	0.1µF		25V
C7016	1-162-970-11	CERAMIC CHIP	0.01µF	10%	25V	C7061	1-164-156-11	CERAMIC CHIP	0.1µF		25V
C7017	1-164-156-11	CERAMIC CHIP	0.1µF		25V						
C7018	1-162-923-11	CERAMIC CHIP	47pF	5%	50V	C7062	1-164-156-11	CERAMIC CHIP	0.1µF		25V
C7019	1-162-923-11	CERAMIC CHIP	47pF	5%	50V	C7064	1-126-395-11	ELECT CHIP	22µF	20%	16V
C7020	1-162-923-11	CERAMIC CHIP	47pF	5%	50V	C7065	1-162-970-11	CERAMIC CHIP	0.01µF	10%	25V
C7021	1-124-779-00	ELECT CHIP	10µF	20%	16V	C7066	1-162-970-11	CERAMIC CHIP	0.01µF	10%	25V
C7022	1-115-416-11	CERAMIC CHIP	0.001µF	5%	25V	C7067	1-162-970-11	CERAMIC CHIP	0.01µF	10%	25V
C7023	1-162-927-11	CERAMIC CHIP	100pF	5%	50V	C7068	1-162-970-11	CERAMIC CHIP	0.01µF	10%	25V
C7024	1-124-779-00	ELECT CHIP	10µF	20%	16V	C7069	1-162-970-11	CERAMIC CHIP	0.01µF	10%	25V
C7025	1-164-156-11	CERAMIC CHIP	0.1µF		25V	C7070	1-164-156-11	CERAMIC CHIP	0.1µF		25V
C7026	1-124-779-00	ELECT CHIP	10µF	20%	16V	C7071	1-164-156-11	CERAMIC CHIP	0.1µF		25V
C7027	1-164-156-11	CERAMIC CHIP	0.1µF		25V	C7078	1-164-156-11	CERAMIC CHIP	0.1µF		25V
C7028	1-164-156-11	CERAMIC CHIP	0.1µF		25V	C7079	1-164-156-11	CERAMIC CHIP	0.1µF		25V
C7029	1-164-156-11	CERAMIC CHIP	0.1µF		25V	C7080	1-164-156-11	CERAMIC CHIP	0.1µF		25V
C7030	1-162-927-11	CERAMIC CHIP	100pF	5%	50V	<b>CONNECTOR</b>					
C7031	1-162-927-11	CERAMIC CHIP	100pF	5%	50V	* CN7001	1-816-228-31	CONNECTOR, DVI			
C7032	1-162-927-11	CERAMIC CHIP	100pF	5%	50V	* CN7005	1-564-520-11	PLUG, CONNECTOR	5P		
C7033	1-124-779-00	ELECT CHIP	10µF	20%	16V	* CN7006	1-564-524-11	PLUG, CONNECTOR	9P		
C7034	1-164-156-11	CERAMIC CHIP	0.1µF		25V	* CN7007	1-564-519-11	PLUG, CONNECTOR	4P		
C7035	1-164-156-11	CERAMIC CHIP	0.1µF		25V	<b>DIODE</b>					
C7036	1-164-156-11	CERAMIC CHIP	0.1µF		25V	D7001	8-719-914-43	DIODE		DAN202K	
C7037	1-164-156-11	CERAMIC CHIP	0.1µF		25V	D7002	8-719-069-55	DIODE		UDZSTE-175.6B	
C7038	1-164-156-11	CERAMIC CHIP	0.1µF		25V	D7003	8-719-069-55	DIODE		UDZSTE-175.6B	
C7039	1-126-395-11	ELECT CHIP	22µF	20%	16V	D7004	8-719-069-55	DIODE		UDZSTE-175.6B	
C7040	1-162-921-11	CERAMIC CHIP	33pF	5%	50V	D7006	8-719-069-55	DIODE		UDZSTE-175.6B	
C7041	1-164-156-11	CERAMIC CHIP	0.1µF		25V	<b>FERRITE BEAD</b>					
C7042	1-164-156-11	CERAMIC CHIP	0.1µF		25V	FB7001	1-414-760-21	FERRITE		0µH	
C7043	1-164-156-11	CERAMIC CHIP	0.1µF		25V	FB7002	1-414-760-21	FERRITE		0µH	
C7044	1-164-156-11	CERAMIC CHIP	0.1µF		25V	FB7003	1-414-760-21	FERRITE		0µH	
C7045	1-164-156-11	CERAMIC CHIP	0.1µF		25V	FB7004	1-414-760-21	FERRITE		0µH	
C7046	1-164-156-11	CERAMIC CHIP	0.1µF		25V	<b>FILTER</b>					
C7047	1-164-156-11	CERAMIC CHIP	0.1µF		25V	FL7001	1-400-087-21	FILTER, EMI REMOVAL (SMD)			
C7048	1-164-156-11	CERAMIC CHIP	0.1µF		25V	FL7002	1-234-560-21	FILTER, LOW PASS			
C7049	1-164-156-11	CERAMIC CHIP	0.1µF		25V	FL7003	1-234-559-21	FILTER, LOW PASS			
C7050	1-164-156-11	CERAMIC CHIP	0.1µF		25V	FL7004	1-234-559-21	FILTER, LOW PASS			
C7051	1-164-156-11	CERAMIC CHIP	0.1µF		25V	<b>IC</b>					
C7052	1-164-156-11	CERAMIC CHIP	0.1µF		25V	IC7001	8-759-672-79	IC		M24C02-WMN6T(A)	
C7053	1-164-156-11	CERAMIC CHIP	0.1µF		25V	IC7002	8-749-015-18	IC		PQ07VZ012ZP	
C7056	1-126-395-11	ELECT CHIP	22µF	20%	16V	IC7003	8-749-015-18	IC		PQ07VZ012ZP	
C7057	1-162-921-11	CERAMIC CHIP	33pF	5%	50V	IC7004	6-702-080-01	IC		GM7030-H	
C7058	1-164-156-11	CERAMIC CHIP	0.1µF		25V	IC7005	6-802-346-01	IC		ST72631K4M1/NNLTR	
C7059	1-164-156-11	CERAMIC CHIP	0.1µF		25V						





REF.NO.	PART NO.	DESCRIPTION	VALUES			REF.NO.	PART NO.	DESCRIPTION	VALUES		
IC7006	8-759-714-06	IC	M24C16-WMN6T(A)			R7057	1-216-864-11	SHORT CHIP			
IC7007	6-702-170-01	IC	PACDN006S			R7058	1-216-833-11	METAL CHIP	10K	5%	1/10W
IC7008	6-702-170-01	IC	PACDN006S			R7059	1-216-864-11	SHORT CHIP			
IC7009	6-702-170-01	IC	PACDN006S			R7060	1-216-833-11	METAL CHIP	10K	5%	1/10W
<b><u>JACK</u></b>						R7062	1-216-864-11	SHORT CHIP			
J7000	1-580-441-51	JACK, PIN	2P			R7063	1-216-809-11	METAL CHIP	100	5%	1/10W
<b><u>COIL</u></b>						R7064	1-216-809-11	METAL CHIP	100	5%	1/10W
L7001	1-412-058-11	INDUCTOR	10μH			R7065	1-216-833-11	METAL CHIP	10K	5%	1/10W
L7002	1-412-058-11	INDUCTOR	10μH			R7066	1-218-694-11	METAL CHIP	1.2K	0.50%	1/10W
<b><u>RESISTOR</u></b>						R7067	1-216-833-11	METAL CHIP	10K	5%	1/10W
R7003	1-216-821-11	METAL CHIP	1K	5%	1/10W	R7068	1-216-801-11	METAL CHIP	22	5%	1/10W
R7004	1-218-852-11	METAL CHIP	1.6K	0.50%	1/10W	R7069	1-216-801-11	METAL CHIP	22	5%	1/10W
R7007	1-216-821-11	METAL CHIP	1K	5%	1/10W	R7071	1-216-803-11	METAL CHIP	33	5%	1/10W
R7012	1-216-821-11	METAL CHIP	1K	5%	1/10W	R7072	1-216-803-11	METAL CHIP	33	5%	1/10W
R7013	1-216-821-11	METAL CHIP	1K	5%	1/10W	R7075	1-218-676-11	METAL CHIP	220	0.50%	1/10W
R7014	1-216-821-11	METAL CHIP	1K	5%	1/10W	R7080	1-218-704-11	METAL CHIP	3.3K	0.50%	1/10W
R7015	1-216-833-11	METAL CHIP	10K	5%	1/10W	R7087	1-218-680-11	METAL CHIP	330	0.50%	1/10W
R7016	1-216-833-11	METAL CHIP	10K	5%	1/10W	R7096	1-216-833-11	METAL CHIP	10K	5%	1/10W
R7020	1-216-833-11	METAL CHIP	10K	5%	1/10W	R7097	1-216-809-11	METAL CHIP	100	5%	1/10W
R7021	1-216-833-11	METAL CHIP	10K	5%	1/10W	R7098	1-216-809-11	METAL CHIP	100	5%	1/10W
R7023	1-216-833-11	METAL CHIP	10K	5%	1/10W	R7099	1-216-809-11	METAL CHIP	100	5%	1/10W
R7024	1-216-833-11	METAL CHIP	10K	5%	1/10W	R7101	1-216-864-11	SHORT CHIP			
R7025	1-216-833-11	METAL CHIP	10K	5%	1/10W	R7106	1-216-833-11	METAL CHIP	10K	5%	1/10W
R7026	1-216-833-11	METAL CHIP	10K	5%	1/10W	R7108	1-216-805-11	METAL CHIP	47	5%	1/10W
R7029	1-218-692-11	METAL CHIP	1K	0.50%	1/10W	R7109	1-216-805-11	METAL CHIP	47	5%	1/10W
R7030	1-216-864-11	SHORT CHIP				R7111	1-216-864-11	SHORT CHIP			
R7032	1-218-676-11	METAL CHIP	220	0.50%	1/10W	R7112	1-216-864-11	SHORT CHIP			
R7034	1-218-676-11	METAL CHIP	220	0.50%	1/10W	R7113	1-216-864-11	SHORT CHIP			
R7036	1-218-704-11	METAL CHIP	3.3K	0.50%	1/10W	R7114	1-218-700-11	METAL CHIP	2.2K	0.50%	1/10W
R7037	1-218-676-11	METAL CHIP	220	0.50%	1/10W	R7115	1-218-700-11	METAL CHIP	2.2K	0.50%	1/10W
R7041	1-216-833-11	METAL CHIP	10K	5%	1/10W	R7116	1-218-700-11	METAL CHIP	2.2K	0.50%	1/10W
R7043	1-216-829-11	METAL CHIP	4.7K	5%	1/10W	R7117	1-218-668-11	METAL CHIP	100	0.50%	1/10W
R7044	1-216-829-11	METAL CHIP	4.7K	5%	1/10W	R7119	1-218-668-11	METAL CHIP	100	0.50%	1/10W
R7045	1-216-833-11	METAL CHIP	10K	5%	1/10W	R7121	1-216-864-11	SHORT CHIP			
R7047	1-216-833-11	METAL CHIP	10K	5%	1/10W	R7123	1-218-704-11	METAL CHIP	3.3K	0.50%	1/10W
R7050	1-216-864-11	SHORT CHIP				R7124	1-218-680-11	METAL CHIP	330	0.50%	1/10W
R7051	1-216-864-11	SHORT CHIP				R7125	1-218-700-11	METAL CHIP	2.2K	0.50%	1/10W
R7053	1-216-833-11	METAL CHIP	10K	5%	1/10W	R7126	1-216-864-11	SHORT CHIP			
R7054	1-216-833-11	METAL CHIP	10K	5%	1/10W	<b><u>CRYSTAL</u></b>					
R7056	1-216-833-11	METAL CHIP	10K	5%	1/10W	X7001	1-795-568-21	VIBRATOR, CRYSTAL			
						X7002	1-795-567-21	VIBRATOR, CRYSTAL			



REF.NO.	PART NO.	DESCRIPTION	VALUES	REF.NO.	PART NO.	DESCRIPTION	VALUES
 <p><b>Due to the complexity of this board, performing component level field repairs is not recommended. If service is required, complete board replacement is the preferred repair method. Data is provided for reference only.</b></p> <p><b>* A-1302-353-A BM BOARD, COMPLETE</b></p> <p><b><u>CAPACITOR</u></b></p>				C3129	1-162-970-11	CERAMIC CHIP	0.01μF 10% 25V
				C3130	1-162-970-11	CERAMIC CHIP	0.01μF 10% 25V
				C3131	1-162-970-11	CERAMIC CHIP	0.01μF 10% 25V
				C3132	1-162-970-11	CERAMIC CHIP	0.01μF 10% 25V
				C3133	1-162-970-11	CERAMIC CHIP	0.01μF 10% 25V
				C3134	1-162-970-11	CERAMIC CHIP	0.01μF 10% 25V
				C3135	1-162-970-11	CERAMIC CHIP	0.01μF 10% 25V
				C3136	1-162-970-11	CERAMIC CHIP	0.01μF 10% 25V
				C3137	1-162-970-11	CERAMIC CHIP	0.01μF 10% 25V
				C3138	1-162-970-11	CERAMIC CHIP	0.01μF 10% 25V
C3032	1-164-156-11	CERAMIC CHIP	0.1μF 25V	C3139	1-162-970-11	CERAMIC CHIP	0.01μF 10% 25V
C3035	1-117-681-11	ELECT CHIP	100μF 20% 16V	C3140	1-162-970-11	CERAMIC CHIP	0.01μF 10% 25V
C3036	1-164-156-11	CERAMIC CHIP	0.1μF 25V	C3141	1-162-970-11	CERAMIC CHIP	0.01μF 10% 25V
C3037	1-126-206-11	ELECT CHIP	100μF 20% 6.3V	C3142	1-162-970-11	CERAMIC CHIP	0.01μF 10% 25V
C3038	1-162-970-11	CERAMIC CHIP	0.01μF 10% 25V	C3143	1-162-970-11	CERAMIC CHIP	0.01μF 10% 25V
C3039	1-164-156-11	CERAMIC CHIP	0.1μF 25V	C3144	1-162-970-11	CERAMIC CHIP	0.01μF 10% 25V
C3040	1-162-970-11	CERAMIC CHIP	0.01μF 10% 25V	C3145	1-162-970-11	CERAMIC CHIP	0.01μF 10% 25V
C3100	1-162-964-11	CERAMIC CHIP	0.001μF 10% 50V	C3146	1-126-206-11	ELECT CHIP	100μF 20% 6.3V
C3101	1-162-964-11	CERAMIC CHIP	0.001μF 10% 50V	C3147	1-162-970-11	CERAMIC CHIP	0.01μF 10% 25V
C3102	1-124-779-00	ELECT CHIP	10μF 20% 16V	C3148	1-162-970-11	CERAMIC CHIP	0.01μF 10% 25V
C3104	1-162-970-11	CERAMIC CHIP	0.01μF 10% 25V	C3149	1-162-970-11	CERAMIC CHIP	0.01μF 10% 25V
C3105	1-162-970-11	CERAMIC CHIP	0.01μF 10% 25V	C3150	1-162-970-11	CERAMIC CHIP	0.01μF 10% 25V
C3106	1-162-970-11	CERAMIC CHIP	0.01μF 10% 25V	C3151	1-162-970-11	CERAMIC CHIP	0.01μF 10% 25V
C3107	1-162-970-11	CERAMIC CHIP	0.01μF 10% 25V	C3152	1-162-970-11	CERAMIC CHIP	0.01μF 10% 25V
C3108	1-162-970-11	CERAMIC CHIP	0.01μF 10% 25V	C3153	1-107-826-11	CERAMIC CHIP	0.1μF 10% 16V
C3109	1-162-970-11	CERAMIC CHIP	0.01μF 10% 25V	C3154	1-137-710-11	CERAMIC CHIP	10μF 20% 6.3V
C3110	1-162-970-11	CERAMIC CHIP	0.01μF 10% 25V	C3155	1-107-826-11	CERAMIC CHIP	0.1μF 10% 16V
C3111	1-162-970-11	CERAMIC CHIP	0.01μF 10% 25V	C3156	1-107-826-11	CERAMIC CHIP	0.1μF 10% 16V
C3112	1-162-970-11	CERAMIC CHIP	0.01μF 10% 25V	C3157	1-137-710-11	CERAMIC CHIP	10μF 20% 6.3V
C3113	1-126-204-11	ELECT CHIP	47μF 20% 16V	C3158	1-107-826-11	CERAMIC CHIP	0.1μF 10% 16V
C3114	1-164-156-11	CERAMIC CHIP	0.1μF 25V	C3159	1-107-826-11	CERAMIC CHIP	0.1μF 10% 16V
C3115	1-164-156-11	CERAMIC CHIP	0.1μF 25V	C3160	1-107-826-11	CERAMIC CHIP	0.1μF 10% 16V
C3116	1-126-204-11	ELECT CHIP	47μF 20% 16V	C3161	1-107-826-11	CERAMIC CHIP	0.1μF 10% 16V
C3117	1-162-970-11	CERAMIC CHIP	0.01μF 10% 25V	C3162	1-128-357-11	ELECT CHIP	10μF 20% 16V
C3118	1-164-156-11	CERAMIC CHIP	0.1μF 25V	C3163	1-126-206-11	ELECT CHIP	100μF 20% 6.3V
C3119	1-162-970-11	CERAMIC CHIP	0.01μF 10% 25V	C3164	1-164-156-11	CERAMIC CHIP	0.1μF 25V
C3120	1-126-204-11	ELECT CHIP	47μF 20% 16V	C3165	1-164-156-11	CERAMIC CHIP	0.1μF 25V
C3121	1-162-970-11	CERAMIC CHIP	0.01μF 10% 25V	C3166	1-164-156-11	CERAMIC CHIP	0.1μF 25V
C3122	1-126-204-11	ELECT CHIP	47μF 20% 16V	C3167	1-162-970-11	CERAMIC CHIP	0.01μF 10% 25V
C3123	1-162-970-11	CERAMIC CHIP	0.01μF 10% 25V	C3168	1-162-970-11	CERAMIC CHIP	0.01μF 10% 25V
C3124	1-162-970-11	CERAMIC CHIP	0.01μF 10% 25V	C3169	1-126-206-11	ELECT CHIP	100μF 20% 6.3V
C3125	1-162-970-11	CERAMIC CHIP	0.01μF 10% 25V	C3170	1-126-206-11	ELECT CHIP	100μF 20% 6.3V
C3126	1-162-970-11	CERAMIC CHIP	0.01μF 10% 25V	C3171	1-162-970-11	CERAMIC CHIP	0.01μF 10% 25V
C3127	1-162-970-11	CERAMIC CHIP	0.01μF 10% 25V	C3172	1-126-206-11	ELECT CHIP	100μF 20% 6.3V
C3128	1-162-970-11	CERAMIC CHIP	0.01μF 10% 25V				



REF.NO.	PART NO.	DESCRIPTION	VALUES			REF.NO.	PART NO.	DESCRIPTION	VALUES		
C3173	1-162-970-11	CERAMIC CHIP	0.01μF	10%	25V	C3239	1-126-204-11	ELECT CHIP	47μF	20%	16V
C3174	1-124-778-00	ELECT CHIP	22μF	20%	6.3V	C3240	1-164-156-11	CERAMIC CHIP	0.1μF		25V
C3178	1-162-970-11	CERAMIC CHIP	0.01μF	10%	25V	C3241	1-162-970-11	CERAMIC CHIP	0.01μF	10%	25V
C3179	1-162-970-11	CERAMIC CHIP	0.01μF	10%	25V	C3242	1-162-970-11	CERAMIC CHIP	0.01μF	10%	25V
C3180	1-126-206-11	ELECT CHIP	100μF	20%	6.3V	C3243	1-162-970-11	CERAMIC CHIP	0.01μF	10%	25V
C3181	1-162-927-11	CERAMIC CHIP	100pF	5%	50V	C3244	1-162-970-11	CERAMIC CHIP	0.01μF	10%	25V
C3182	1-162-927-11	CERAMIC CHIP	100pF	5%	50V	C3245	1-162-970-11	CERAMIC CHIP	0.01μF	10%	25V
C3183	1-162-927-11	CERAMIC CHIP	100pF	5%	50V	C3246	1-162-970-11	CERAMIC CHIP	0.01μF	10%	25V
C3184	1-162-927-11	CERAMIC CHIP	100pF	5%	50V	C3247	1-164-156-11	CERAMIC CHIP	0.1μF		25V
C3185	1-162-927-11	CERAMIC CHIP	100pF	5%	50V	C3248	1-164-156-11	CERAMIC CHIP	0.1μF		25V
C3186	1-162-927-11	CERAMIC CHIP	100pF	5%	50V	C3250	1-162-970-11	CERAMIC CHIP	0.01μF	10%	25V
C3188	1-162-927-11	CERAMIC CHIP	100pF	5%	50V	C3251	1-162-970-11	CERAMIC CHIP	0.01μF	10%	25V
C3189	1-162-927-11	CERAMIC CHIP	100pF	5%	50V	C3252	1-128-996-11	ELECT CHIP	4.7μF	20%	50V
C3201	1-162-970-11	CERAMIC CHIP	0.01μF	10%	25V	C3253	1-164-156-11	CERAMIC CHIP	0.1μF		25V
C3202	1-162-970-11	CERAMIC CHIP	0.01μF	10%	25V	C3254	1-164-156-11	CERAMIC CHIP	0.1μF		25V
C3203	1-126-206-11	ELECT CHIP	100μF	20%	6.3V	C3255	1-127-760-11	CERAMIC CHIP	4.7μF	10%	6.3V
C3204	1-162-970-11	CERAMIC CHIP	0.01μF	10%	25V	C3256	1-162-970-11	CERAMIC CHIP	0.01μF	10%	25V
C3205	1-162-970-11	CERAMIC CHIP	0.01μF	10%	25V	C3304	1-162-970-11	CERAMIC CHIP	0.01μF	10%	25V
C3206	1-126-204-11	ELECT CHIP	47μF	20%	16V	C3305	1-126-206-11	ELECT CHIP	100μF	20%	6.3V
C3207	1-162-970-11	CERAMIC CHIP	0.01μF	10%	25V	C3306	1-162-970-11	CERAMIC CHIP	0.01μF	10%	25V
C3208	1-162-970-11	CERAMIC CHIP	0.01μF	10%	25V	C3307	1-162-970-11	CERAMIC CHIP	0.01μF	10%	25V
C3209	1-126-206-11	ELECT CHIP	100μF	20%	6.3V	C3308	1-162-970-11	CERAMIC CHIP	0.01μF	10%	25V
C3210	1-162-970-11	CERAMIC CHIP	0.01μF	10%	25V	C3309	1-162-970-11	CERAMIC CHIP	0.01μF	10%	25V
C3211	1-162-970-11	CERAMIC CHIP	0.01μF	10%	25V	C3310	1-126-206-11	ELECT CHIP	100μF	20%	6.3V
C3212	1-162-970-11	CERAMIC CHIP	0.01μF	10%	25V	C3311	1-162-970-11	CERAMIC CHIP	0.01μF	10%	25V
C3213	1-162-970-11	CERAMIC CHIP	0.01μF	10%	25V	C3312	1-162-970-11	CERAMIC CHIP	0.01μF	10%	25V
C3214	1-162-970-11	CERAMIC CHIP	0.01μF	10%	25V	C3313	1-162-970-11	CERAMIC CHIP	0.01μF	10%	25V
C3215	1-162-970-11	CERAMIC CHIP	0.01μF	10%	25V	C3316	1-162-970-11	CERAMIC CHIP	0.01μF	10%	25V
C3216	1-162-970-11	CERAMIC CHIP	0.01μF	10%	25V	C3318	1-124-779-00	ELECT CHIP	10μF	20%	16V
C3217	1-126-206-11	ELECT CHIP	100μF	20%	6.3V	C3319	1-162-970-11	CERAMIC CHIP	0.01μF	10%	25V
C3218	1-162-970-11	CERAMIC CHIP	0.01μF	10%	25V	C3320	1-162-970-11	CERAMIC CHIP	0.01μF	10%	25V
C3219	1-162-970-11	CERAMIC CHIP	0.01μF	10%	25V	C3321	1-162-970-11	CERAMIC CHIP	0.01μF	10%	25V
C3222	1-162-970-11	CERAMIC CHIP	0.01μF	10%	25V	C3322	1-162-970-11	CERAMIC CHIP	0.01μF	10%	25V
C3224	1-162-970-11	CERAMIC CHIP	0.01μF	10%	25V	C3323	1-124-779-00	ELECT CHIP	10μF	20%	16V
C3225	1-162-970-11	CERAMIC CHIP	0.01μF	10%	25V	C3325	1-162-970-11	CERAMIC CHIP	0.01μF	10%	25V
C3227	1-162-970-11	CERAMIC CHIP	0.01μF	10%	25V	C3326	1-162-970-11	CERAMIC CHIP	0.01μF	10%	25V
C3229	1-162-970-11	CERAMIC CHIP	0.01μF	10%	25V	C3328	1-162-970-11	CERAMIC CHIP	0.01μF	10%	25V
C3231	1-162-970-11	CERAMIC CHIP	0.01μF	10%	25V	C3329	1-162-970-11	CERAMIC CHIP	0.01μF	10%	25V
C3232	1-162-970-11	CERAMIC CHIP	0.01μF	10%	25V	C3330	1-162-970-11	CERAMIC CHIP	0.01μF	10%	25V
C3233	1-162-970-11	CERAMIC CHIP	0.01μF	10%	25V	C3332	1-125-891-11	CERAMIC CHIP	0.47μF	10%	10V
C3235	1-162-970-11	CERAMIC CHIP	0.01μF	10%	25V	C3333	1-162-970-11	CERAMIC CHIP	0.01μF	10%	25V
C3236	1-162-970-11	CERAMIC CHIP	0.01μF	10%	25V	C3334	1-162-970-11	CERAMIC CHIP	0.01μF	10%	25V
C3237	1-126-204-11	ELECT CHIP	47μF	20%	16V	C3335	1-162-970-11	CERAMIC CHIP	0.01μF	10%	25V
C3238	1-162-970-11	CERAMIC CHIP	0.01μF	10%	25V	C3336	1-128-994-21	ELECT CHIP	47μF	20%	10V



REF.NO.	PART NO.	DESCRIPTION	VALUES			REF.NO.	PART NO.	DESCRIPTION	VALUES		
C3337	1-162-970-11	CERAMIC CHIP	0.01μF	10%	25V	C3387	1-164-156-11	CERAMIC CHIP	0.1μF		25V
C3338	1-164-156-11	CERAMIC CHIP	0.1μF		25V	C3388	1-164-156-11	CERAMIC CHIP	0.1μF		25V
C3339	1-126-204-11	ELECT CHIP	47μF	20%	16V	C3389	1-162-970-11	CERAMIC CHIP	0.01μF	10%	25V
C3340	1-162-970-11	CERAMIC CHIP	0.01μF	10%	25V	C3390	1-126-205-11	ELECT CHIP	47μF	20%	6.3V
C3341	1-126-204-11	ELECT CHIP	47μF	20%	16V	C3391	1-162-970-11	CERAMIC CHIP	0.01μF	10%	25V
C3342	1-107-826-11	CERAMIC CHIP	0.1μF	10%	16V	C3392	1-162-970-11	CERAMIC CHIP	0.01μF	10%	25V
C3343	1-162-970-11	CERAMIC CHIP	0.01μF	10%	25V	C3393	1-162-970-11	CERAMIC CHIP	0.01μF	10%	25V
C3344	1-162-916-11	CERAMIC CHIP	12pF	5%	50V	C3394	1-126-204-11	ELECT CHIP	47μF	20%	16V
C3345	1-162-916-11	CERAMIC CHIP	12pF	5%	50V	C3395	1-124-779-00	ELECT CHIP	10μF	20%	16V
C3346	1-126-204-11	ELECT CHIP	47μF	20%	16V	C3396	1-124-779-00	ELECT CHIP	10μF	20%	16V
C3347	1-164-156-11	CERAMIC CHIP	0.1μF		25V	C3397	1-125-837-91	CERAMIC CHIP	1μF	10%	6.3V
C3348	1-107-826-11	CERAMIC CHIP	0.1μF	10%	16V	C3398	1-162-970-11	CERAMIC CHIP	0.01μF	10%	25V
C3351	1-162-970-11	CERAMIC CHIP	0.01μF	10%	25V	C3453	1-124-779-00	ELECT CHIP	10μF	20%	16V
C3352	1-126-204-11	ELECT CHIP	47μF	20%	16V	C3454	1-164-156-11	CERAMIC CHIP	0.1μF		25V
C3353	1-162-970-11	CERAMIC CHIP	0.01μF	10%	25V	C3455	1-124-779-00	ELECT CHIP	10μF	20%	16V
C3354	1-162-970-11	CERAMIC CHIP	0.01μF	10%	25V	C3456	1-164-156-11	CERAMIC CHIP	0.1μF		25V
C3355	1-107-826-11	CERAMIC CHIP	0.1μF	10%	16V	C3457	1-124-779-00	ELECT CHIP	10μF	20%	16V
C3356	1-107-826-11	CERAMIC CHIP	0.1μF	10%	16V	C3458	1-164-156-11	CERAMIC CHIP	0.1μF		25V
C3357	1-164-156-11	CERAMIC CHIP	0.1μF		25V	C3459	1-162-970-11	CERAMIC CHIP	0.01μF	10%	25V
C3358	1-126-206-11	ELECT CHIP	100μF	20%	6.3V	C3460	1-162-927-11	CERAMIC CHIP	100pF	5%	50V
C3360	1-162-970-11	CERAMIC CHIP	0.01μF	10%	25V	C3461	1-162-970-11	CERAMIC CHIP	0.01μF	10%	25V
C3361	1-162-970-11	CERAMIC CHIP	0.01μF	10%	25V	C3462	1-162-927-11	CERAMIC CHIP	100pF	5%	50V
C3362	1-162-923-11	CERAMIC CHIP	47pF	5%	50V	C3463	1-162-970-11	CERAMIC CHIP	0.01μF	10%	25V
C3363	1-162-970-11	CERAMIC CHIP	0.01μF	10%	25V	C3465	1-162-927-11	CERAMIC CHIP	100pF	5%	50V
C3366	1-162-970-11	CERAMIC CHIP	0.01μF	10%	25V	C3466	1-162-970-11	CERAMIC CHIP	0.01μF	10%	25V
C3367	1-164-156-11	CERAMIC CHIP	0.1μF		25V			<b>CONNECTOR</b>			
C3368	1-164-156-11	CERAMIC CHIP	0.1μF		25V						
C3369	1-124-779-00	ELECT CHIP	10μF	20%	16V	*	CN3001	1-816-448-11	CONNECTOR, BOARD TO BOARD	50P	
C3370	1-162-970-11	CERAMIC CHIP	0.01μF	10%	25V			<b>DIODE</b>			
C3371	1-162-970-11	CERAMIC CHIP	0.01μF	10%	25V	D3101	8-719-066-11	DIODE			1PS184-115
C3372	1-162-970-11	CERAMIC CHIP	0.01μF	10%	25V	D3102	8-719-066-10	DIODE			1PS181-115
C3373	1-162-970-11	CERAMIC CHIP	0.01μF	10%	25V	D3205	8-719-066-11	DIODE			1PS184-115
C3374	1-162-970-11	CERAMIC CHIP	0.01μF	10%	25V	D3206	8-719-066-10	DIODE			1PS181-115
C3375	1-126-206-11	ELECT CHIP	100μF	20%	6.3V	D3301	8-719-066-11	DIODE			1PS184-115
C3376	1-126-206-11	ELECT CHIP	100μF	20%	6.3V	D3302	8-719-066-10	DIODE			1PS181-115
C3377	1-162-970-11	CERAMIC CHIP	0.01μF	10%	25V			<b>FERRITE BEAD</b>			
C3380	1-164-156-11	CERAMIC CHIP	0.1μF		25V	FB3101	1-414-234-22	FERRITE			0μH
C3381	1-164-156-11	CERAMIC CHIP	0.1μF		25V	FB3203	1-469-110-21	FERRITE			0μH
C3382	1-126-204-11	ELECT CHIP	47μF	20%	16V	FB3204	1-216-864-11	SHORT CHIP			
C3383	1-162-970-11	CERAMIC CHIP	0.01μF	10%	25V	FB3302	1-216-864-11	SHORT CHIP			
C3384	1-164-156-11	CERAMIC CHIP	0.1μF		25V	FB3303	1-216-864-11	SHORT CHIP			
C3385	1-126-205-11	ELECT CHIP	47μF	20%	6.3V						
C3386	1-126-205-11	ELECT CHIP	47μF	20%	6.3V						



REF.NO.	PART NO.	DESCRIPTION	VALUES	REF.NO.	PART NO.	DESCRIPTION	VALUES
<b><u>FILTER</u></b>				<b><u>COIL</u></b>			
FL3000	1-234-177-21	FERRITE	0μH	L3101	1-412-029-11	INDUCTOR	10μH
FL3001	1-234-177-21	FERRITE	0μH	L3102	1-469-555-21	INDUCTOR	10μH
FL3003	1-234-177-21	FERRITE	0μH	L3103	1-412-029-11	INDUCTOR	10μH
FL3100	1-234-677-21	FILTER, EMI		L3104	1-412-026-11	INDUCTOR	1μH
FL3101	1-234-560-21	FILTER, LOW PASS		L3105	1-412-026-11	INDUCTOR	1μH
FL3102	1-234-559-21	FILTER, LOW PASS		L3106	1-412-026-11	INDUCTOR	1μH
FL3103	1-234-559-21	FILTER, LOW PASS		L3107	1-412-029-11	INDUCTOR	10μH
FL3104	1-234-177-21	FERRITE	0μH	L3201	1-412-026-11	INDUCTOR	1μH
FL3105	1-234-177-21	FERRITE	0μH	L3202	1-469-561-21	INDUCTOR	100μH
FL3106	1-234-177-21	FERRITE	0μH	L3203	1-469-561-21	INDUCTOR	100μH
FL3107	1-234-177-21	FERRITE	0μH	L3204	1-412-026-11	INDUCTOR	1μH
FL3200	1-234-177-21	FERRITE	0μH	L3205	1-412-026-11	INDUCTOR	1μH
FL3201	1-234-177-21	FERRITE	0μH	L3302	1-469-561-21	INDUCTOR	100μH
FL3301	1-781-923-21	FILTER, LOW PASS (SMD)		L3303	1-469-561-21	INDUCTOR	100μH
FL3302	1-234-177-21	FERRITE	0μH	L3304	1-469-555-21	INDUCTOR	10μH
FL3304	1-234-177-21	FERRITE	0μH	L3305	1-469-555-21	INDUCTOR	10μH
FL3305	1-234-177-21	FERRITE	0μH	L3306	1-469-555-21	INDUCTOR	10μH
FL3306	1-234-177-21	FERRITE	0μH	L3307	1-469-555-21	INDUCTOR	10μH
<b><u>IC</u></b>				L3308	1-412-029-11	INDUCTOR	10μH
IC3101	8-752-425-02	IC	CXD3802BQ	L3311	1-469-555-21	INDUCTOR	10μH
IC3102	6-703-430-01	IC	MT48LC2M32B2TG-6-Y94W	L3312	1-412-026-11	INDUCTOR	1μH
IC3103	6-703-772-11	IC	LMH6658MMX/NOPB	L3313	1-412-029-11	INDUCTOR	10μH
IC3104	6-703-772-11	IC	LMH6658MMX/NOPB	L3314	1-412-026-11	INDUCTOR	1μH
IC3105	8-759-712-65	IC	PQ070XZ01ZP	L3315	1-412-026-11	INDUCTOR	1μH
IC3106	8-759-712-65	IC	PQ070XZ01ZP	L3316	1-469-555-21	INDUCTOR	10μH
IC3201	8-752-422-52	IC	CXD2097BQ	L3317	1-412-026-11	INDUCTOR	1μH
IC3202	6-703-791-01	IC	MSM56V16160F-8T3FM1	L3318	1-469-555-21	INDUCTOR	10μH
IC3204	8-759-669-78	IC	TLC2933IPWR-12	<b><u>TRANSISTOR</u></b>			
IC3205	8-759-712-65	IC	PQ070XZ01ZP	Q3101	8-729-102-07	TRANSISTOR	2SC2223-F13
IC3301	8-759-672-57	IC	CXD9509AQ	Q3102	8-729-122-63	TRANSISTOR	2SA1226-E4
IC3302	6-703-430-01	IC	MT48LC2M32B2TG-6-Y94W	Q3103	8-729-102-07	TRANSISTOR	2SC2223-F13
IC3303	8-752-409-20	IC	CXD2309AQ	Q3104	8-729-122-63	TRANSISTOR	2SA1226-E4
IC3305	8-759-669-75	IC	TLC2932IPWR	Q3105	8-729-102-07	TRANSISTOR	2SC2223-F13
IC3306	8-759-485-79	IC	TC7SET08FU(TE85L)	Q3106	8-729-122-63	TRANSISTOR	2SA1226-E4
IC3307	8-759-485-79	IC	TC7SET08FU(TE85L)	Q3107	8-729-028-28	TRANSISTOR	2SK2036(TE85L)
IC3308	8-759-485-79	IC	TC7SET08FU(TE85L)	Q3108	8-729-028-28	TRANSISTOR	2SK2036(TE85L)
IC3309	8-759-082-57	IC	TC7W04FU	Q3109	8-729-010-25	TRANSISTOR	MSD601-RT1
IC3310	8-759-712-65	IC	PQ070XZ01ZP	Q3110	8-729-102-07	TRANSISTOR	2SC2223-F13
IC3311	8-759-833-72	IC	NJM2870F25-TE2	Q3111	8-729-102-07	TRANSISTOR	2SC2223-F13
				Q3112	8-729-102-07	TRANSISTOR	2SC2223-F13
				Q3113	8-729-010-25	TRANSISTOR	MSD601-RT1



REF.NO.	PART NO.	DESCRIPTION	VALUES	REF.NO.	PART NO.	DESCRIPTION	VALUES
Q3201	8-729-028-28	TRANSISTOR	2SK2036(TE85L)	R3051	1-543-949-22	FERRITE	0μH
Q3202	8-729-028-28	TRANSISTOR	2SK2036(TE85L)	R3052	1-216-805-11	METAL CHIP	47 5% 1/10W
Q3203	8-729-010-25	TRANSISTOR	MSD601-RT1	R3053	1-216-805-11	METAL CHIP	47 5% 1/10W
Q3204	8-729-010-05	TRANSISTOR	MSB709-RT1	R3054	1-216-805-11	METAL CHIP	47 5% 1/10W
Q3301	8-729-010-25	TRANSISTOR	MSD601-RT1	R3055	1-543-949-22	FERRITE	0μH
Q3302	8-729-010-25	TRANSISTOR	MSD601-RT1	R3056	1-543-949-22	FERRITE	0μH
Q3304	8-729-010-25	TRANSISTOR	MSD601-RT1	R3101	1-216-801-11	METAL CHIP	22 5% 1/10W
Q3305	8-729-010-25	TRANSISTOR	MSD601-RT1	R3102	1-216-833-11	METAL CHIP	10K 5% 1/10W
Q3306	8-729-028-28	TRANSISTOR	2SK2036(TE85L)	R3103	1-216-823-11	METAL CHIP	1.5K 5% 1/10W
Q3307	8-729-028-28	TRANSISTOR	2SK2036(TE85L)	R3104	1-216-805-11	METAL CHIP	47 5% 1/10W
Q3308	8-729-010-25	TRANSISTOR	MSD601-RT1	R3105	1-218-830-11	METAL CHIP	200 0.50% 1/10W
Q3309	8-729-010-05	TRANSISTOR	MSB709-RT1	R3106	1-216-809-11	METAL CHIP	100 5% 1/10W
Q3310	8-729-010-25	TRANSISTOR	MSD601-RT1	R3107	1-216-820-11	METAL CHIP	820 5% 1/10W
Q3311	8-729-010-05	TRANSISTOR	MSB709-RT1	R3108	1-218-830-11	METAL CHIP	200 0.50% 1/10W
Q3312	8-729-010-25	TRANSISTOR	MSD601-RT1	R3109	1-216-823-11	METAL CHIP	1.5K 5% 1/10W
Q3313	8-729-010-05	TRANSISTOR	MSB709-RT1	R3110	1-216-805-11	METAL CHIP	47 5% 1/10W
Q3314	8-729-102-07	TRANSISTOR	2SC2223-F13	R3111	1-218-834-11	METAL CHIP	300 0.50% 1/10W
Q3315	8-729-102-07	TRANSISTOR	2SC2223-F13	R3112	1-216-809-11	METAL CHIP	100 5% 1/10W
Q3316	8-729-102-07	TRANSISTOR	2SC2223-F13	R3113	1-216-820-11	METAL CHIP	820 5% 1/10W
Q3317	8-729-122-63	TRANSISTOR	2SA1226-E4	R3114	1-218-834-11	METAL CHIP	300 0.50% 1/10W
Q3318	8-729-122-63	TRANSISTOR	2SA1226-E4	R3115	1-216-805-11	METAL CHIP	47 5% 1/10W
Q3319	8-729-122-63	TRANSISTOR	2SA1226-E4	R3116	1-216-805-11	METAL CHIP	47 5% 1/10W
	<b>RESISTOR</b>			R3117	1-216-823-11	METAL CHIP	1.5K 5% 1/10W
R3023	1-216-864-11	SHORT CHIP		R3118	1-216-805-11	METAL CHIP	47 5% 1/10W
R3024	1-216-827-11	METAL CHIP	3.3K 5% 1/10W	R3119	1-216-805-11	METAL CHIP	47 5% 1/10W
R3032	1-216-864-11	SHORT CHIP		R3120	1-218-834-11	METAL CHIP	300 0.50% 1/10W
R3034	1-216-864-11	SHORT CHIP		R3121	1-216-809-11	METAL CHIP	100 5% 1/10W
R3035	1-543-949-22	FERRITE	0μH	R3122	1-216-820-11	METAL CHIP	820 5% 1/10W
R3036	1-543-949-22	FERRITE	0μH	R3123	1-218-834-11	METAL CHIP	300 0.50% 1/10W
R3037	1-543-949-22	FERRITE	0μH	R3124	1-216-864-11	SHORT CHIP	
R3038	1-216-864-11	SHORT CHIP		R3125	1-216-864-11	SHORT CHIP	
R3039	1-216-864-11	SHORT CHIP		R3129	1-216-805-11	METAL CHIP	47 5% 1/10W
R3040	1-216-864-11	SHORT CHIP		R3130	1-216-805-11	METAL CHIP	47 5% 1/10W
R3041	1-543-949-22	FERRITE	0μH	R3131	1-216-833-11	METAL CHIP	10K 5% 1/10W
R3042	1-543-949-22	FERRITE	0μH	R3132	1-216-833-11	METAL CHIP	10K 5% 1/10W
R3043	1-216-805-11	METAL CHIP	47 5% 1/10W	R3133	1-216-809-11	METAL CHIP	100 5% 1/10W
R3044	1-216-805-11	METAL CHIP	47 5% 1/10W	R3134	1-216-809-11	METAL CHIP	100 5% 1/10W
R3045	1-216-805-11	METAL CHIP	47 5% 1/10W	R3135	1-543-949-22	FERRITE	0μH
R3046	1-543-949-22	FERRITE	0μH	R3136	1-543-949-22	FERRITE	0μH
R3047	1-543-949-22	FERRITE	0μH	R3137	1-216-864-11	SHORT CHIP	
R3048	1-543-949-22	FERRITE	0μH	R3138	1-216-864-11	SHORT CHIP	
R3049	1-543-949-22	FERRITE	0μH	R3141	1-218-839-11	METAL CHIP	470 0.50% 1/10W
R3050	1-543-949-22	FERRITE	0μH	R3142	1-218-839-11	METAL CHIP	470 0.50% 1/10W



REF.NO.	PART NO.	DESCRIPTION	VALUES			REF.NO.	PART NO.	DESCRIPTION	VALUES		
R3143	1-218-839-11	METAL CHIP	470	0.50%	1/10W	R3221	1-216-864-11	SHORT CHIP			
R3144	1-218-841-11	METAL CHIP	560	0.50%	1/10W	R3236	1-216-833-11	METAL CHIP	10K	5%	1/10W
R3145	1-218-841-11	METAL CHIP	560	0.50%	1/10W	R3237	1-216-833-11	METAL CHIP	10K	5%	1/10W
R3146	1-218-841-11	METAL CHIP	560	0.50%	1/10W	R3239	1-216-864-11	SHORT CHIP			
R3147	1-218-855-11	METAL CHIP	2.2K	0.50%	1/10W	R3240	1-216-809-11	METAL CHIP	100	5%	1/10W
R3148	1-218-867-11	METAL CHIP	6.8K	0.50%	1/10W	R3241	1-216-809-11	METAL CHIP	100	5%	1/10W
R3150	1-218-861-11	METAL CHIP	3.9K	0.50%	1/10W	R3244	1-216-864-11	SHORT CHIP			
R3151	1-218-861-11	METAL CHIP	3.9K	0.50%	1/10W	R3246	1-216-864-11	SHORT CHIP			
R3152	1-218-861-11	METAL CHIP	3.9K	0.50%	1/10W	R3247	1-216-864-11	SHORT CHIP			
R3153	1-211-977-11	METAL CHIP	22	0.50%	1/10W	R3248	1-216-864-11	SHORT CHIP			
R3154	1-216-809-11	METAL CHIP	100	5%	1/10W	R3249	1-216-864-11	SHORT CHIP			
R3155	1-216-809-11	METAL CHIP	100	5%	1/10W	R3251	1-216-833-11	METAL CHIP	10K	5%	1/10W
R3156	1-216-847-11	METAL CHIP	150K	5%	1/10W	R3252	1-216-813-11	METAL CHIP	220	5%	1/10W
R3158	1-216-809-11	METAL CHIP	100	5%	1/10W	R3253	1-216-864-11	SHORT CHIP			
R3159	1-216-819-11	METAL CHIP	680	5%	1/10W	R3255	1-216-801-11	METAL CHIP	22	5%	1/10W
R3160	1-216-819-11	METAL CHIP	680	5%	1/10W	R3256	1-218-860-11	METAL CHIP	3.6K	0.50%	1/10W
R3161	1-216-819-11	METAL CHIP	680	5%	1/10W	R3257	1-216-809-11	METAL CHIP	100	5%	1/10W
R3162	1-216-864-11	SHORT CHIP				R3258	1-218-831-11	METAL CHIP	220	0.50%	1/10W
R3163	1-218-851-11	METAL CHIP	1.5K	0.50%	1/10W	R3259	1-218-859-11	METAL CHIP	3.3K	0.50%	1/10W
R3164	1-218-863-11	METAL CHIP	4.7K	0.50%	1/10W	R3260	1-218-831-11	METAL CHIP	220	0.50%	1/10W
R3165	1-216-864-11	SHORT CHIP				R3261	1-218-831-11	METAL CHIP	220	0.50%	1/10W
R3170	1-216-801-11	METAL CHIP	22	5%	1/10W	R3262	1-216-809-11	METAL CHIP	100	5%	1/10W
R3171	1-216-864-11	SHORT CHIP				R3264	1-216-815-11	METAL CHIP	330	5%	1/10W
R3172	1-216-864-11	SHORT CHIP				R3265	1-216-853-11	METAL CHIP	470K	5%	1/10W
R3176	1-216-864-11	SHORT CHIP				R3266	1-216-837-11	METAL CHIP	22K	5%	1/10W
R3178	1-218-847-11	METAL CHIP	1K	0.50%	1/10W	R3267	1-216-813-11	METAL CHIP	220	5%	1/10W
R3179	1-218-847-11	METAL CHIP	1K	0.50%	1/10W	R3268	1-216-821-11	METAL CHIP	1K	5%	1/10W
R3181	1-216-833-11	METAL CHIP	10K	5%	1/10W	R3269	1-216-853-11	METAL CHIP	470K	5%	1/10W
R3182	1-216-833-11	METAL CHIP	10K	5%	1/10W	R3270	1-216-827-11	METAL CHIP	3.3K	5%	1/10W
R3183	1-218-847-11	METAL CHIP	1K	0.50%	1/10W	R3271	1-218-842-11	METAL CHIP	620	0.50%	1/10W
R3184	1-218-847-11	METAL CHIP	1K	0.50%	1/10W	R3272	1-216-805-11	METAL CHIP	47	5%	1/10W
R3185	1-218-873-11	METAL CHIP	12K	0.50%	1/10W	R3273	1-216-814-11	METAL CHIP	270	5%	1/10W
R3186	1-216-833-11	METAL CHIP	10K	5%	1/10W	R3276	1-543-949-22	FERRITE	0μH		
R3190	1-216-864-11	SHORT CHIP				R3277	1-543-949-22	FERRITE	0μH		
R3192	1-216-833-11	METAL CHIP	10K	5%	1/10W	R3280	1-218-838-11	METAL CHIP	430	0.50%	1/10W
R3193	1-216-833-11	METAL CHIP	10K	5%	1/10W	R3281	1-218-847-11	METAL CHIP	1K	0.50%	1/10W
R3194	1-216-833-11	METAL CHIP	10K	5%	1/10W	R3282	1-218-873-11	METAL CHIP	12K	0.50%	1/10W
R3195	1-216-833-11	METAL CHIP	10K	5%	1/10W	R3302	1-216-801-11	METAL CHIP	22	5%	1/10W
R3196	1-216-833-11	METAL CHIP	10K	5%	1/10W	R3303	1-216-821-11	METAL CHIP	1K	5%	1/10W
R3197	1-216-864-11	SHORT CHIP				R3304	1-216-821-11	METAL CHIP	1K	5%	1/10W
R3198	1-216-864-11	SHORT CHIP				R3305	1-218-859-11	METAL CHIP	3.3K	0.50%	1/10W
R3199	1-216-855-11	METAL CHIP	680K	5%	1/10W	R3306	1-216-801-11	METAL CHIP	22	5%	1/10W
R3201	1-216-801-11	METAL CHIP	22	5%	1/10W	R3307	1-216-821-11	METAL CHIP	1K	5%	1/10W
R3219	1-216-864-11	SHORT CHIP				R3308	1-216-821-11	METAL CHIP	1K	5%	1/10W



REF.NO.	PART NO.	DESCRIPTION	VALUES			REF.NO.	PART NO.	DESCRIPTION	VALUES		
R3310	1-216-801-11	METAL CHIP	22	5%	1/10W	R3368	1-216-864-11	SHORT CHIP			
R3311	1-216-821-11	METAL CHIP	1K	5%	1/10W	R3369	1-216-864-11	SHORT CHIP			
R3312	1-216-821-11	METAL CHIP	1K	5%	1/10W	R3370	1-216-864-11	SHORT CHIP			
R3315	1-216-809-11	METAL CHIP	100	5%	1/10W	R3371	1-216-809-11	METAL CHIP	100	5%	1/10W
						R3374	1-216-817-11	METAL CHIP	470	5%	1/10W
R3316	1-216-801-11	METAL CHIP	22	5%	1/10W						
R3317	1-216-801-11	METAL CHIP	22	5%	1/10W	R3375	1-543-949-22	FERRITE	0μH		
R3318	1-216-813-11	METAL CHIP	220	5%	1/10W	R3376	1-543-949-22	FERRITE	0μH		
R3320	1-216-864-11	SHORT CHIP				R3377	1-218-847-11	METAL CHIP	1K	0.50%	1/10W
R3321	1-216-823-11	METAL CHIP	1.5K	5%	1/10W	R3378	1-218-847-11	METAL CHIP	1K	0.50%	1/10W
						R3383	1-216-805-11	METAL CHIP	47	5%	1/10W
R3322	1-216-805-11	METAL CHIP	47	5%	1/10W						
R3323	1-216-815-11	METAL CHIP	330	5%	1/10W	R3384	1-211-987-11	METAL CHIP	56	0.50%	1/10W
R3325	1-216-809-11	METAL CHIP	100	5%	1/10W	R3385	1-211-985-11	METAL CHIP	47	0.50%	1/10W
R3329	1-216-864-11	SHORT CHIP				R3386	1-211-987-11	METAL CHIP	56	0.50%	1/10W
R3330	1-216-821-11	METAL CHIP	1K	5%	1/10W	R3387	1-211-985-11	METAL CHIP	47	0.50%	1/10W
						R3388	1-216-864-11	SHORT CHIP			
R3331	1-216-819-11	METAL CHIP	680	5%	1/10W						
R3333	1-216-833-11	METAL CHIP	10K	5%	1/10W	R3389	1-216-864-11	SHORT CHIP			
R3334	1-216-833-11	METAL CHIP	10K	5%	1/10W	R3391	1-216-829-11	METAL CHIP	4.7K	5%	1/10W
R3335	1-216-825-11	METAL CHIP	2.2K	5%	1/10W	R3392	1-216-818-11	METAL CHIP	560	5%	1/10W
R3336	1-216-855-11	METAL CHIP	680K	5%	1/10W	R3393	1-216-809-11	METAL CHIP	100	5%	1/10W
						R3395	1-216-817-11	METAL CHIP	470	5%	1/10W
R3337	1-216-801-11	METAL CHIP	22	5%	1/10W						
R3340	1-216-864-11	SHORT CHIP				R3396	1-216-864-11	SHORT CHIP			
R3341	1-216-864-11	SHORT CHIP				R3401	1-216-805-11	METAL CHIP	47	5%	1/10W
R3342	1-216-821-11	METAL CHIP	1K	5%	1/10W	R3402	1-216-801-11	METAL CHIP	22	5%	1/10W
R3343	1-216-821-11	METAL CHIP	1K	5%	1/10W	R3403	1-216-821-11	METAL CHIP	1K	5%	1/10W
						R3404	1-216-809-11	METAL CHIP	100	5%	1/10W
R3344	1-216-821-11	METAL CHIP	1K	5%	1/10W						
R3345	1-216-821-11	METAL CHIP	1K	5%	1/10W	R3405	1-216-809-11	METAL CHIP	100	5%	1/10W
R3346	1-216-821-11	METAL CHIP	1K	5%	1/10W	R3406	1-216-801-11	METAL CHIP	22	5%	1/10W
R3347	1-216-821-11	METAL CHIP	1K	5%	1/10W	R3407	1-216-801-11	METAL CHIP	22	5%	1/10W
R3348	1-216-821-11	METAL CHIP	1K	5%	1/10W	R3408	1-216-801-11	METAL CHIP	22	5%	1/10W
						R3409	1-216-809-11	METAL CHIP	100	5%	1/10W
R3349	1-216-821-11	METAL CHIP	1K	5%	1/10W						
R3350	1-216-821-11	METAL CHIP	1K	5%	1/10W	R3410	1-218-855-11	METAL CHIP	2.2K	0.50%	1/10W
R3351	1-216-809-11	METAL CHIP	100	5%	1/10W	R3411	1-218-859-11	METAL CHIP	3.3K	0.50%	1/10W
R3353	1-216-821-11	METAL CHIP	1K	5%	1/10W	R3412	1-216-817-11	METAL CHIP	470	5%	1/10W
R3354	1-216-821-11	METAL CHIP	1K	5%	1/10W	R3413	1-216-801-11	METAL CHIP	22	5%	1/10W
						R3414	1-211-987-11	METAL CHIP	56	0.50%	1/10W
R3355	1-216-821-11	METAL CHIP	1K	5%	1/10W						
R3356	1-216-821-11	METAL CHIP	1K	5%	1/10W	R3415	1-211-985-11	METAL CHIP	47	0.50%	1/10W
R3357	1-216-821-11	METAL CHIP	1K	5%	1/10W	R3416	1-216-809-11	METAL CHIP	100	5%	1/10W
R3358	1-216-821-11	METAL CHIP	1K	5%	1/10W	R3417	1-216-817-11	METAL CHIP	470	5%	1/10W
R3359	1-216-809-11	METAL CHIP	100	5%	1/10W	R3418	1-216-801-11	METAL CHIP	22	5%	1/10W
						R3419	1-216-809-11	METAL CHIP	100	5%	1/10W
R3360	1-216-805-11	METAL CHIP	47	5%	1/10W						
R3362	1-216-817-11	METAL CHIP	470	5%	1/10W	R3420	1-218-823-11	METAL CHIP	100	0.50%	1/10W
R3363	1-216-809-11	METAL CHIP	100	5%	1/10W	R3421	1-218-823-11	METAL CHIP	100	0.50%	1/10W
R3367	1-216-805-11	METAL CHIP	47	5%	1/10W	R3422	1-218-823-11	METAL CHIP	100	0.50%	1/10W
						R3425	1-216-817-11	METAL CHIP	470	5%	1/10W





REF.NO.	PART NO.	DESCRIPTION	VALUES			REF.NO.	PART NO.	DESCRIPTION	VALUES
R3426	1-216-801-11	METAL CHIP	22	5%	1/10W	RB3116	1-236-908-11	NETWORK RESISTOR(CHIP)	10K
R3448	1-216-864-11	SHORT CHIP				RB3117	1-236-908-11	NETWORK RESISTOR(CHIP)	10K
R3450	1-211-969-11	METAL CHIP	10	0.50%	1/10W	RB3201	1-239-409-11	NETWORK RESISTOR(CHIP)	47
R3451	1-218-825-11	METAL CHIP	120	0.50%	1/10W	RB3202	1-239-409-11	NETWORK RESISTOR(CHIP)	47
R3452	1-218-833-11	METAL CHIP	270	0.50%	1/10W	RB3203	1-239-409-11	NETWORK RESISTOR(CHIP)	47
R3453	1-211-973-11	METAL CHIP	15	0.50%	1/10W	RB3204	1-239-409-11	NETWORK RESISTOR(CHIP)	47
R3454	1-218-825-11	METAL CHIP	120	0.50%	1/10W	RB3205	1-233-576-11	RES, CHIP NETWORK	100
R3455	1-218-833-11	METAL CHIP	270	0.50%	1/10W	RB3206	1-233-576-11	RES, CHIP NETWORK	100
R3456	1-211-977-11	METAL CHIP	22	0.50%	1/10W	RB3207	1-233-576-11	RES, CHIP NETWORK	100
R3457	1-218-825-11	METAL CHIP	120	0.50%	1/10W	RB3208	1-233-576-11	RES, CHIP NETWORK	100
R3458	1-218-833-11	METAL CHIP	270	0.50%	1/10W	RB3209	1-233-576-11	RES, CHIP NETWORK	100
R3459	1-211-977-11	METAL CHIP	22	0.50%	1/10W	RB3210	1-233-576-11	RES, CHIP NETWORK	100
R3460	1-218-825-11	METAL CHIP	120	0.50%	1/10W	RB3303	1-233-576-11	RES, CHIP NETWORK	100
R3461	1-218-833-11	METAL CHIP	270	0.50%	1/10W	RB3304	1-233-576-11	RES, CHIP NETWORK	100
R3462	1-218-825-11	METAL CHIP	120	0.50%	1/10W	RB3305	1-233-576-11	RES, CHIP NETWORK	100
R3463	1-218-833-11	METAL CHIP	270	0.50%	1/10W	RB3306	1-233-576-11	RES, CHIP NETWORK	100
R3464	1-218-825-11	METAL CHIP	120	0.50%	1/10W	RB3309	1-233-576-11	RES, CHIP NETWORK	100
R3465	1-218-833-11	METAL CHIP	270	0.50%	1/10W	RB3310	1-233-576-11	RES, CHIP NETWORK	100
R3466	1-218-833-11	METAL CHIP	270	0.50%	1/10W	RB3311	1-233-576-11	RES, CHIP NETWORK	100
R3467	1-218-833-11	METAL CHIP	270	0.50%	1/10W	RB3312	1-233-576-11	RES, CHIP NETWORK	100
R3468	1-218-833-11	METAL CHIP	270	0.50%	1/10W	RB3313	1-233-813-11	RES, NETWORK 150	(3216)
R3469	1-218-844-11	METAL CHIP	750	0.50%	1/10W	RB3314	1-233-813-11	RES, NETWORK 150	(3216)
R3470	1-216-821-11	METAL CHIP	1K	5%	1/10W	RB3315	1-233-813-11	RES, NETWORK 150	(3216)
R3471	1-216-864-11	SHORT CHIP				RB3316	1-233-813-11	RES, NETWORK 150	(3216)
R3472	1-216-864-11	SHORT CHIP				RB3318	1-233-813-11	RES, NETWORK 150	(3216)
R3473	1-216-864-11	SHORT CHIP				RB3319	1-233-813-11	RES, NETWORK 150	(3216)
R3474	1-216-821-11	METAL CHIP	1K	5%	1/10W	<b>CRYSTAL</b>			
R3475	1-216-821-11	METAL CHIP	1K	5%	1/10W	X3101	1-795-951-21	QUARTZ CRYSTAL OSCILLATOR(SMD)	
<b>RESISTOR BRIDGE</b>						X3301	1-781-887-21	VIBRATOR, CRYSTAL	
RB3101	1-236-908-11	NETWORK RESISTOR(CHIP)	10K			<b>DS</b>			
RB3102	1-239-409-11	NETWORK RESISTOR(CHIP)	47			* <b>A-1405-077-A</b>	<b>DS BOARD, MOUNTED</b>		
RB3103	1-239-409-11	NETWORK RESISTOR(CHIP)	47			7-447-019-03	MATERIAL, COATING CT-301S(1KG)		
RB3104	1-239-409-11	NETWORK RESISTOR(CHIP)	47			7-682-952-09	SCREW +PSW 3X16		
RB3105	1-239-409-11	NETWORK RESISTOR(CHIP)	47			<b>CAPACITOR</b>			
RB3106	1-233-576-11	RES, CHIP NETWORK	100			C9401	1-162-927-11	CERAMIC CHIP	100pF 5% 50V
RB3107	1-233-576-11	RES, CHIP NETWORK	100			C9402	1-162-927-11	CERAMIC CHIP	100pF 5% 50V
RB3108	1-233-576-11	RES, CHIP NETWORK	100			C9403	1-162-927-11	CERAMIC CHIP	100pF 5% 50V
RB3109	1-233-576-11	RES, CHIP NETWORK	100			C9404	1-126-968-11	ELECT	100µF 20% 50V
RB3110	1-233-576-11	RES, CHIP NETWORK	100			C9405	1-162-927-11	CERAMIC CHIP	100pF 5% 50V
RB3111	1-233-576-11	RES, CHIP NETWORK	100			C9406	1-162-927-11	CERAMIC CHIP	100pF 5% 50V
RB3112	1-233-576-11	RES, CHIP NETWORK	100			C9407	1-126-968-11	ELECT	100µF 20% 50V
RB3113	1-233-576-11	RES, CHIP NETWORK	100			C9408	1-162-927-11	CERAMIC CHIP	100pF 5% 50V
RB3114	1-236-908-11	NETWORK RESISTOR(CHIP)	10K						
RB3115	1-236-908-11	NETWORK RESISTOR(CHIP)	10K						

NOTE: The components identified by shading and  $\triangle$  mark are critical for safety. Replace only with part number specified.

NOTE: Les composants identifiés par un triangle et une marque  $\triangle$  sont critiques pour la sécurité. Ne les remplacer que par une pièce portant le numéro spécifique.

REF.NO.	PART NO.	DESCRIPTION	VALUES			REF.NO.	PART NO.	DESCRIPTION	VALUES		
C9409	1-126-968-11	ELECT	100 $\mu$ F	20%	50V	<b>IC LINK</b>					
C9410	1-126-968-11	ELECT	100 $\mu$ F	20%	50V	$\triangle$ PS9400	1-533-595-31	IC LINK	3.15A	90V	
C9411	1-162-927-11	CERAMIC CHIP	100pF	5%	50V	$\triangle$ PS9401	1-533-595-31	IC LINK	3.15A	90V	
C9413	1-162-927-11	CERAMIC CHIP	100pF	5%	50V	$\triangle$ PS9402	1-533-595-31	IC LINK	3.15A	90V	
C9415	1-126-949-11	ELECT	220 $\mu$ F	20%	35V	$\triangle$ PS9403	1-533-595-31	IC LINK	3.15A	90V	
C9416	1-126-949-11	ELECT	220 $\mu$ F	20%	35V	$\triangle$ PS9404	1-533-595-31	IC LINK	3.15A	90V	
C9417	1-126-949-11	ELECT	220 $\mu$ F	20%	35V	$\triangle$ PS9405	1-533-595-31	IC LINK	3.15A	90V	
C9418	1-162-927-11	CERAMIC CHIP	100pF	5%	50V	<b>RESISTOR</b>					
C9419	1-162-927-11	CERAMIC CHIP	100pF	5%	50V	R9400	1-216-809-11	METAL CHIP	100	5%	1/10W
C9420	1-126-949-11	ELECT	220 $\mu$ F	20%	35V	R9401	1-216-809-11	METAL CHIP	100	5%	1/10W
C9423	1-162-927-11	CERAMIC CHIP	100pF	5%	50V	R9402	1-216-809-11	METAL CHIP	100	5%	1/10W
C9425	1-162-927-11	CERAMIC CHIP	100pF	5%	50V	R9403	1-216-809-11	METAL CHIP	100	5%	1/10W
C9426	1-104-665-11	ELECT	100 $\mu$ F	20%	25V	R9404	1-216-809-11	METAL CHIP	100	5%	1/10W
C9427	1-104-665-11	ELECT	100 $\mu$ F	20%	25V	R9405	1-216-809-11	METAL CHIP	100	5%	1/10W
C9428	1-104-665-11	ELECT	100 $\mu$ F	20%	25V	R9406	1-216-809-11	METAL CHIP	100	5%	1/10W
<b>CONNECTOR</b>						R9407	1-218-823-11	METAL CHIP	100	0.50%	1/10W
*	CN9400	1-793-494-11	CONNECTOR, BOARD TO BOARD	40P		R9408	1-218-823-11	METAL CHIP	100	0.50%	1/10W
*	CN9401	1-764-334-11	PIN, CONNECTOR(PCB)(V TYPE)	11P		R9409	1-218-823-11	METAL CHIP	100	0.50%	1/10W
*	CN9403	1-564-515-11	PLUG, CONNECTOR	12P		R9410	1-216-809-11	METAL CHIP	100	5%	1/10W
*	CN9404	1-564-507-11	PLUG, CONNECTOR	4P		R9411	1-218-863-11	METAL CHIP	4.7K	0.50%	1/10W
*	CN9405	1-564-507-11	PLUG, CONNECTOR	4P		R9412	1-218-823-11	METAL CHIP	100	0.50%	1/10W
*	CN9406	1-564-507-11	PLUG, CONNECTOR	4P		R9413	1-218-823-11	METAL CHIP	100	0.50%	1/10W
*	CN9407	1-564-507-11	PLUG, CONNECTOR	4P		R9414	1-218-823-11	METAL CHIP	100	0.50%	1/10W
*	CN9409	1-564-506-11	PLUG, CONNECTOR	3P		R9415	1-218-863-11	METAL CHIP	4.7K	0.50%	1/10W
<b>DIODE</b>						R9416	1-218-863-11	METAL CHIP	4.7K	0.50%	1/10W
D9407	8-719-991-33	DIODE	1SS133T-77			R9417	1-216-809-11	METAL CHIP	100	5%	1/10W
D9409	8-719-110-17	DIODE	RD10ESB2			R9418	1-218-863-11	METAL CHIP	4.7K	0.50%	1/10W
<b>IC</b>						R9419	1-218-863-11	METAL CHIP	4.7K	0.50%	1/10W
IC9400	8-749-019-08	IC	STK392-560			R9420	1-218-863-11	METAL CHIP	4.7K	0.50%	1/10W
IC9401	8-749-019-08	IC	STK392-560			R9424	1-218-863-11	METAL CHIP	4.7K	0.50%	1/10W
<b>COIL</b>						R9425	1-218-863-11	METAL CHIP	4.7K	0.50%	1/10W
L9400	1-414-187-11	INDUCTOR	47 $\mu$ H			R9427	1-214-808-11	METAL	4.7	1%	1/2W
L9401	1-414-187-11	INDUCTOR	47 $\mu$ H			R9428	1-214-808-11	METAL	4.7	1%	1/2W
L9402	1-414-187-11	INDUCTOR	47 $\mu$ H			R9430	1-214-808-11	METAL	4.7	1%	1/2W
L9403	1-414-187-11	INDUCTOR	47 $\mu$ H			R9432	1-214-808-11	METAL	4.7	1%	1/2W
L9404	1-412-533-21	INDUCTOR	47 $\mu$ H			R9433	1-218-863-11	METAL CHIP	4.7K	0.50%	1/10W
L9405	1-412-533-21	INDUCTOR	47 $\mu$ H			R9434	1-214-808-11	METAL	4.7	1%	1/2W
L9406	1-412-533-21	INDUCTOR	47 $\mu$ H			R9435	1-218-863-11	METAL CHIP	4.7K	0.50%	1/10W
L9407	1-412-533-21	INDUCTOR	47 $\mu$ H			R9436	1-214-808-11	METAL	4.7	1%	1/2W
						R9437	1-214-808-11	METAL	4.7	1%	1/2W
						R9438	1-214-808-11	METAL	4.7	1%	1/2W
						R9440	1-214-808-11	METAL	4.7	1%	1/2W
						R9441	1-214-808-11	METAL	4.7	1%	1/2W



REF.NO.	PART NO.	DESCRIPTION	VALUES			REF.NO.	PART NO.	DESCRIPTION	VALUES		
R9442	1-214-808-11	METAL	4.7	1%	1/2W	C6911	1-126-947-11	ELECT	47µF	20%	35V
R9443	1-214-808-11	METAL	4.7	1%	1/2W	C6914	1-117-219-11	CERAMIC	68pF	5%	1KV
R9446	1-214-808-11	METAL	4.7	1%	1/2W	C6915	1-117-219-11	CERAMIC	68pF	5%	1KV
R9447	1-214-808-11	METAL	4.7	1%	1/2W	C6916	1-100-624-11	FILM	4700pF	3%	800V
R9448	1-218-863-11	METAL CHIP	4.7K	0.50%	1/10W	C6917	1-126-968-11	ELECT	100µF	20%	50V
R9450	1-218-887-11	METAL CHIP	47K	0.50%	1/10W	C6918	1-126-968-11	ELECT	100µF	20%	50V
R9451	1-214-808-11	METAL	4.7	1%	1/2W	C6919	1-126-926-11	ELECT	1000µF	20%	10V
R9452	1-214-808-11	METAL	4.7	1%	1/2W	C6921	1-128-547-11	ELECT	6800µF	20%	16V
R9453	1-218-863-11	METAL CHIP	4.7K	0.50%	1/10W	C6923	1-126-933-11	ELECT	100µF	20%	16V
R9454	1-214-808-11	METAL	4.7	1%	1/2W	C6925	1-162-970-11	CERAMIC CHIP	0.01µF	10%	25V
R9455	1-214-808-11	METAL	4.7	1%	1/2W	C6926	1-126-935-11	ELECT	470µF	20%	16V
R9456	1-214-808-11	METAL	4.7	1%	1/2W	C6929	1-126-933-11	ELECT	100µF	20%	16V
R9457	1-214-808-11	METAL	4.7	1%	1/2W	C6930	1-162-970-11	CERAMIC CHIP	0.01µF	10%	25V
R9458	1-214-808-11	METAL	4.7	1%	1/2W	C6931	1-107-826-11	CERAMIC CHIP	0.1µF	10%	16V
R9459	1-214-808-11	METAL	4.7	1%	1/2W	C6932	1-162-964-11	CERAMIC CHIP	0.001µF	10%	50V
R9460	1-214-808-11	METAL	4.7	1%	1/2W						
R9461	1-214-808-11	METAL	4.7	1%	1/2W	<b>CONNECTOR</b>					
R9462	1-214-808-11	METAL	4.7	1%	1/2W	* CN6900	1-580-844-11	PIN, CONNECTOR (POWER)			
R9463	1-214-808-11	METAL	4.7	1%	1/2W	* CN6901	1-691-756-11	PIN, CONNECTOR (PC BOARD)		2P	
R9464	1-214-808-11	METAL	4.7	1%	1/2W	* CN6902	1-564-512-11	PLUG, CONNECTOR		9P	
R9465	1-214-808-11	METAL	4.7	1%	1/2W	* CN6905	1-564-506-11	PLUG, CONNECTOR		3P	
R9466	1-243-532-71	METAL OXIDE	120	5%	3W	<b>DIODE</b>					
R9467	1-243-532-71	METAL OXIDE	120	5%	3W	D6901	8-719-083-78	DIODE		10ERA60-TP	
R9468	1-214-808-11	METAL	4.7	1%	1/2W	D6902	8-719-082-03	DIODE		MM3Z15VT1	
R9470	1-214-808-11	METAL	4.7	1%	1/2W	D6903	8-719-082-03	DIODE		MM3Z15VT1	
R9471	1-243-532-71	METAL OXIDE	120	5%	3W	D6904	8-719-082-03	DIODE		MM3Z15VT1	
R9472	1-243-532-71	METAL OXIDE	120	5%	3W	D6905	8-719-082-03	DIODE		MM3Z15VT1	
R9473	1-243-532-71	METAL OXIDE	120	5%	3W	D6907	6-500-567-21	DIODE		10ERB20-TB5	
R9474	1-243-532-71	METAL OXIDE	120	5%	3W	D6908	6-500-567-21	DIODE		10ERB20-TB5	
						D6909	8-719-022-97	DIODE		D2S4µF	
						D6910	8-719-510-12	DIODE		D10SC4M	
						D6913	8-719-068-71	DIODE		PTZ-TE25-13A	
						D6914	8-719-082-03	DIODE		MM3Z15VT1	
						D6916	8-719-081-97	DIODE		MMDL914T1	
						<b>FERRITE BEAD</b>					
						FB6900	1-469-578-11	FERRITE		1.1µH	
						<b>IC</b>					
						IC6900	6-703-355-01	IC		MCZ3001DA	
						IC6901	8-759-586-17	IC		TL1431CZ-AP	
						IC6902	8-759-470-65	IC		PQ05RD1B	



\* **A-1405-081-A G2 BOARD, MOUNTED**  
4-382-854-01 SCREW (M3X8), P, SW (+)

**CAPACITOR**

C6900	1-137-639-21	MYLAR	0.47µF	10%	450V
C6902	1-162-964-11	CERAMIC CHIP	0.001µF	10%	50V
C6903	1-126-964-11	ELECT	10µF	20%	50V
C6904	1-126-959-11	ELECT	0.47µF	20%	50V
C6906	1-126-967-11	ELECT	47µF	20%	50V
C6907	1-162-970-11	CERAMIC CHIP	0.01µF	10%	25V
C6908	1-136-479-11	FILM	0.001µF	5%	100V
C6909	1-136-165-00	FILM	0.1µF	5%	50V

NOTE: The components identified by shading and  $\triangle$  mark are critical for safety. Replace only with part number specified.

NOTE: Les composants identifiés par un trame et une marque  $\triangle$  sont critiques pour la sécurité. Ne les remplacer que par une pièce portant le numéro spécifique.

**G2** **QI**

REF.NO.	PART NO.	DESCRIPTION	VALUES	REF.NO.	PART NO.	DESCRIPTION	VALUES
<b><u>JUMPER WIRE</u></b>				R6941	1-216-841-11	METAL CHIP	47K 5% 1/10W
JW6900	1-469-578-11	FERRITE	1.1 $\mu$ H	R6942	1-216-841-11	METAL CHIP	47K 5% 1/10W
<b><u>COIL</u></b>				<b><u>TRANSFORMER</u></b>			
L6900	1-412-537-31	INDUCTOR	100 $\mu$ H	T6900	1-439-879-11	TRANSFORMER, CONVERTER (PIT)	
L6902	1-412-525-31	INDUCTOR	10 $\mu$ H	<b>QI</b>			
L6903	1-406-659-11	INDUCTOR	10 $\mu$ H				
<b><u>PHOTO COUPLER</u></b>				Due to the complexity of this board, performing component level field repairs is not recommended. If it is determined that this board has malfunctioned, the Complete Q Box Assembly (P/N A-1606-037-A) must be replaced. Data is provided for reference only.			
$\triangle$ PH6900	8-749-016-81	PHOTO COUPLER	PC123Y22	* <b>A-1302-164-A</b> <b>QI BOARD, COMPLETE</b>			
<b><u>TRANSISTOR</u></b>				4-088-898-01 <b>CARTON</b>			
Q6900	8-729-052-29	TRANSISTOR	2SK2876-01MR-F122	<b><u>CAPACITOR</u></b>			
Q6901	8-729-052-29	TRANSISTOR	2SK2876-01MR-F122	C601	1-165-845-21	TANTAL. CHIP	47 $\mu$ F 20%
Q6904	8-729-010-05	TRANSISTOR	MSB709-RT1	C602	1-164-156-11	CERAMIC CHIP	0.1 $\mu$ F 25V
Q6905	8-729-010-25	TRANSISTOR	MSD601-RT1	C603	1-165-845-21	TANTAL. CHIP	47 $\mu$ F 20%
<b><u>RESISTOR</u></b>				C604	1-165-989-11	CERAMIC CHIP	10 $\mu$ F 10% 6.3V
R6902	1-218-869-11	METAL CHIP	8.2K 0.50% 1/10W	C605	1-165-845-21	TANTAL. CHIP	47 $\mu$ F 20%
R6903	1-218-837-11	METAL CHIP	390 0.50% 1/10W	C606	1-164-156-11	CERAMIC CHIP	0.1 $\mu$ F 25V
R6904	1-245-478-21	METAL	470K 1% 1/4W	C607	1-162-974-11	CERAMIC CHIP	0.01 $\mu$ F 50V
R6905	1-218-873-11	METAL CHIP	12K 0.50% 1/10W	C608	1-164-156-11	CERAMIC CHIP	0.1 $\mu$ F 25V
R6907	1-245-478-21	METAL	470K 1% 1/4W	C609	1-164-156-11	CERAMIC CHIP	0.1 $\mu$ F 25V
R6908	1-218-823-11	METAL CHIP	100 0.50% 1/10W	C610	1-164-156-11	CERAMIC CHIP	0.1 $\mu$ F 25V
R6909	1-212-897-00	FUSIBLE	470 5% 1/4W	C611	1-164-156-11	CERAMIC CHIP	0.1 $\mu$ F 25V
R6910	1-249-393-11	CARBON	10 5% 1/4W	C612	1-164-156-11	CERAMIC CHIP	0.1 $\mu$ F 25V
R6911	1-249-393-11	CARBON	10 5% 1/4W	C613	1-164-156-11	CERAMIC CHIP	0.1 $\mu$ F 25V
R6912	1-216-833-11	METAL CHIP	10K 5% 1/10W	C614	1-164-156-11	CERAMIC CHIP	0.1 $\mu$ F 25V
R6913	1-216-833-11	METAL CHIP	10K 5% 1/10W	C615	1-164-156-11	CERAMIC CHIP	0.1 $\mu$ F 25V
R6916	1-216-817-11	METAL CHIP	470 5% 1/10W	C616	1-164-156-11	CERAMIC CHIP	0.1 $\mu$ F 25V
R6917	1-216-864-11	SHORT CHIP		C617	1-164-156-11	CERAMIC CHIP	0.1 $\mu$ F 25V
R6918	1-220-926-81	FUSIBLE	0.47 10% 1/2W	C618	1-164-156-11	CERAMIC CHIP	0.1 $\mu$ F 25V
R6920	1-216-363-21	METAL OXIDE	0.33 5% 2W	C619	1-164-156-11	CERAMIC CHIP	0.1 $\mu$ F 25V
R6921	1-216-821-11	METAL CHIP	1K 5% 1/10W	C620	1-164-156-11	CERAMIC CHIP	0.1 $\mu$ F 25V
R6922	1-249-393-11	CARBON	10 5% 1/4W	C621	1-165-989-11	CERAMIC CHIP	10 $\mu$ F 10% 6.3V
R6923	1-216-821-11	METAL CHIP	1K 5% 1/10W	C702	1-164-156-11	CERAMIC CHIP	0.1 $\mu$ F 25V
R6924	1-216-864-11	SHORT CHIP		C703	1-164-156-11	CERAMIC CHIP	0.1 $\mu$ F 25V
R6925	1-249-393-11	CARBON	10 5% 1/4W	C704	1-164-156-11	CERAMIC CHIP	0.1 $\mu$ F 25V
R6927	1-216-833-11	METAL CHIP	10K 5% 1/10W	C705	1-164-156-11	CERAMIC CHIP	0.1 $\mu$ F 25V
R6931	1-218-877-11	METAL CHIP	18K 0.50% 1/10W	C706	1-164-156-11	CERAMIC CHIP	0.1 $\mu$ F 25V
R6932	1-218-867-11	METAL CHIP	6.8K 0.50% 1/10W	C707	1-164-156-11	CERAMIC CHIP	0.1 $\mu$ F 25V
R6936	1-216-821-11	METAL CHIP	1K 5% 1/10W	C708	1-164-156-11	CERAMIC CHIP	0.1 $\mu$ F 25V
R6937	1-216-849-11	METAL CHIP	220K 5% 1/10W				



REF.NO.	PART NO.	DESCRIPTION	VALUES			REF.NO.	PART NO.	DESCRIPTION	VALUES		
C709	1-162-915-11	CERAMIC CHIP	10pF	0.50pF	50V	C805	1-164-156-11	CERAMIC CHIP	0.1μF		25V
C710	1-162-915-11	CERAMIC CHIP	10pF	0.50pF	50V	C806	1-164-156-11	CERAMIC CHIP	0.1μF		25V
C711	1-162-915-11	CERAMIC CHIP	10pF	0.50pF	50V	C807	1-164-156-11	CERAMIC CHIP	0.1μF		25V
C712	1-162-915-11	CERAMIC CHIP	10pF	0.50pF	50V	C808	1-164-156-11	CERAMIC CHIP	0.1μF		25V
C713	1-162-915-11	CERAMIC CHIP	10pF	0.50pF	50V	C809	1-164-156-11	CERAMIC CHIP	0.1μF		25V
C714	1-162-915-11	CERAMIC CHIP	10pF	0.50pF	50V	C810	1-164-156-11	CERAMIC CHIP	0.1μF		25V
C715	1-162-915-11	CERAMIC CHIP	10pF	0.50pF	50V	C811	1-164-156-11	CERAMIC CHIP	0.1μF		25V
C716	1-162-915-11	CERAMIC CHIP	10pF	0.50pF	50V	C812	1-164-156-11	CERAMIC CHIP	0.1μF		25V
C717	1-162-915-11	CERAMIC CHIP	10pF	0.50pF	50V	C813	1-164-156-11	CERAMIC CHIP	0.1μF		25V
C718	1-162-915-11	CERAMIC CHIP	10pF	0.50pF	50V	C814	1-164-156-11	CERAMIC CHIP	0.1μF		25V
C719	1-162-915-11	CERAMIC CHIP	10pF	0.50pF	50V	C815	1-164-156-11	CERAMIC CHIP	0.1μF		25V
C720	1-162-915-11	CERAMIC CHIP	10pF	0.50pF	50V	C816	1-164-156-11	CERAMIC CHIP	0.1μF		25V
C721	1-162-915-11	CERAMIC CHIP	10pF	0.50pF	50V	C817	1-164-156-11	CERAMIC CHIP	0.1μF		25V
C722	1-162-915-11	CERAMIC CHIP	10pF	0.50pF	50V	C818	1-164-156-11	CERAMIC CHIP	0.1μF		25V
C723	1-162-915-11	CERAMIC CHIP	10pF	0.50pF	50V	C819	1-165-989-11	CERAMIC CHIP	10μF	10%	6.3V
C724	1-162-915-11	CERAMIC CHIP	10pF	0.50pF	50V	C820	1-165-989-11	CERAMIC CHIP	10μF	10%	6.3V
C725	1-162-971-11	CERAMIC CHIP	0.001μF	10%	50V	C821	1-162-974-11	CERAMIC CHIP	0.01μF		50V
C726	1-107-826-11	CERAMIC CHIP	0.1μF	10%	16V	C822	1-164-156-11	CERAMIC CHIP	0.1μF		25V
C727	1-162-974-11	CERAMIC CHIP	0.01μF		50V	C823	1-162-974-11	CERAMIC CHIP	0.01μF		50V
C728	1-164-156-11	CERAMIC CHIP	0.1μF		25V	C824	1-125-837-91	CERAMIC CHIP	1μF	10%	6.3V
C729	1-164-156-11	CERAMIC CHIP	0.1μF		25V	C825	1-164-156-11	CERAMIC CHIP	0.1μF		25V
C730	1-162-974-11	CERAMIC CHIP	0.01μF		50V	C826	1-164-156-11	CERAMIC CHIP	0.1μF		25V
C731	1-162-915-11	CERAMIC CHIP	10pF	0.50pF	50V	C828	1-164-156-11	CERAMIC CHIP	0.1μF		25V
C732	1-162-974-11	CERAMIC CHIP	0.01μF		50V	C829	1-162-927-11	CERAMIC CHIP	100pF	5%	50V
C733	1-162-915-11	CERAMIC CHIP	10pF	0.50pF	50V	C830	1-162-927-11	CERAMIC CHIP	100pF	5%	50V
C734	1-165-989-11	CERAMIC CHIP	10μF	10%	6.3V	C832	1-162-971-11	CERAMIC CHIP	0.001μF	10%	50V
C735	1-165-989-11	CERAMIC CHIP	10μF	10%	6.3V	C833	1-162-927-11	CERAMIC CHIP	100pF	5%	50V
C736	1-162-974-11	CERAMIC CHIP	0.01μF		50V	C834	1-162-927-11	CERAMIC CHIP	100pF	5%	50V
C737	1-162-974-11	CERAMIC CHIP	0.01μF		50V	C835	1-164-156-11	CERAMIC CHIP	0.1μF		25V
C738	1-164-156-11	CERAMIC CHIP	0.1μF		25V	C836	1-164-156-11	CERAMIC CHIP	0.1μF		25V
C739	1-115-416-11	CERAMIC CHIP	0.001μF	5%	25V	C837	1-107-826-11	CERAMIC CHIP	0.1μF	10%	16V
C740	1-115-416-11	CERAMIC CHIP	0.001μF	5%	25V	C838	1-164-156-11	CERAMIC CHIP	0.1μF		25V
C741	1-115-416-11	CERAMIC CHIP	0.001μF	5%	25V	C839	1-164-156-11	CERAMIC CHIP	0.1μF		25V
C742	1-125-838-11	CERAMIC CHIP	2.2μF	10%	6.3V	C840	1-107-826-11	CERAMIC CHIP	0.1μF	10%	16V
C743	1-125-838-11	CERAMIC CHIP	2.2μF	10%	6.3V	C841	1-107-826-11	CERAMIC CHIP	0.1μF	10%	16V
C744	1-125-838-11	CERAMIC CHIP	2.2μF	10%	6.3V	<b>CONNECTOR</b>					
C745	1-164-388-91	CERAMIC CHIP	270pF	5%	50V	* CN602	1-817-738-11	CONNECTOR, BOARD TO BOARD 80P			
C746	1-164-156-11	CERAMIC CHIP	0.1μF		25V	* CN701	1-817-737-11	CONNECTOR, BOARD TO BOARD 40P			
C747	1-164-388-91	CERAMIC CHIP	270pF	5%	50V	* CN702	1-815-033-11	CONNECTOR, I LINK			
C748	1-164-156-11	CERAMIC CHIP	0.1μF		25V	* CN703	1-815-164-21	CONNECTOR, I LINK(FLANGE TYPE)			
C749	1-164-388-91	CERAMIC CHIP	270pF	5%	50V	* CN704	1-815-164-21	CONNECTOR, I LINK(FLANGE TYPE)			
C750	1-164-156-11	CERAMIC CHIP	0.1μF		25V						
C803	1-164-156-11	CERAMIC CHIP	0.1μF		25V						
C804	1-164-156-11	CERAMIC CHIP	0.1μF		25V						



REF.NO.	PART NO.	DESCRIPTION	VALUES	REF.NO.	PART NO.	DESCRIPTION	VALUES
<b><u>DIODE</u></b>				R611	1-216-833-11	METAL CHIP	10K 5% 1/10W
D701	8-719-421-71	DIODE	MA132WA	R612	1-216-833-11	METAL CHIP	10K 5% 1/10W
D702	8-719-421-71	DIODE	MA132WA	R613	1-216-833-11	METAL CHIP	10K 5% 1/10W
D703	8-719-421-71	DIODE	MA132WA	R614	1-216-845-11	METAL CHIP	100K 5% 1/10W
<b><u>FERRITE BEAD</u></b>				R616	1-216-845-11	METAL CHIP	100K 5% 1/10W
FB601	1-469-835-21	FERRITE	0μH	R617	1-216-833-11	METAL CHIP	10K 5% 1/10W
FB602	1-469-835-21	FERRITE	0μH	R618	1-216-833-11	METAL CHIP	10K 5% 1/10W
FB801	1-469-835-21	FERRITE	0μH	R619	1-216-864-11	SHORT CHIP	
FB802	1-469-835-21	FERRITE	0μH	R620	1-216-864-11	SHORT CHIP	
<b><u>IC</u></b>				R621	1-216-833-11	METAL CHIP	10K 5% 1/10W
IC601	6-702-958-01	IC	CXD9740GA	R622	1-216-833-11	METAL CHIP	10K 5% 1/10W
IC602	8-759-832-05	IC	BA18BC0FP-E2	R623	1-216-833-11	METAL CHIP	10K 5% 1/10W
IC703	6-702-511-11	IC	MT48LC8M16A2TG-75-Y95WT	R624	1-216-833-11	METAL CHIP	10K 5% 1/10W
IC704	6-704-487-01	IC	TC74LVX74FT(EL)	R625	1-216-833-11	METAL CHIP	10K 5% 1/10W
IC802	6-704-488-01	IC	UPD72894GD-LML-A	R701	1-216-833-11	METAL CHIP	10K 5% 1/10W
IC803	8-759-031-84	IC	SC7S04F	R702	1-216-801-11	METAL CHIP	22 5% 1/10W
IC804	8-759-031-84	IC	SC7S04F	R704	1-216-801-11	METAL CHIP	22 5% 1/10W
IC805	6-702-552-01	IC	BU2374FV-E2	R707	1-216-801-11	METAL CHIP	22 5% 1/10W
IC807	6-703-791-01	IC	MSM56V16160F-8T3FM1	R708	1-218-672-11	METAL CHIP	150 0.50% 1/10W
IC808	6-704-487-01	IC	TC74LVX74FT(EL)	R709	1-216-801-11	METAL CHIP	22 5% 1/10W
<b><u>COIL</u></b>				R710	1-218-711-11	METAL CHIP	6.2K 0.50% 1/10W
L601	1-414-394-11	INDUCTOR	2.2μH	R711	1-216-801-11	METAL CHIP	22 5% 1/10W
L701	1-414-394-11	INDUCTOR	2.2μH	R712	1-216-801-11	METAL CHIP	22 5% 1/10W
L702	1-414-394-11	INDUCTOR	2.2μH	R713	1-216-801-11	METAL CHIP	22 5% 1/10W
L703	1-781-667-22	INDUCTOR	0μH	R714	1-218-662-11	METAL CHIP	56 0.50% 1/10W
L704	1-781-667-22	INDUCTOR	0μH	R715	1-218-662-11	METAL CHIP	56 0.50% 1/10W
L705	1-781-667-22	INDUCTOR	0μH	R716	1-218-662-11	METAL CHIP	56 0.50% 1/10W
L706	1-781-667-22	INDUCTOR	0μH	R717	1-218-662-11	METAL CHIP	56 0.50% 1/10W
L707	1-781-667-22	INDUCTOR	0μH	R719	1-218-662-11	METAL CHIP	56 0.50% 1/10W
L708	1-781-667-22	INDUCTOR	0μH	R721	1-218-662-11	METAL CHIP	56 0.50% 1/10W
L801	1-414-394-11	INDUCTOR	2.2μH	R723	1-216-857-11	METAL CHIP	1M 5% 1/10W
<b><u>RESISTOR</u></b>				R724	1-216-857-11	METAL CHIP	1M 5% 1/10W
R601	1-216-801-11	METAL CHIP	22 5% 1/10W	R725	1-216-857-11	METAL CHIP	1M 5% 1/10W
R602	1-216-801-11	METAL CHIP	22 5% 1/10W	R726	1-218-662-11	METAL CHIP	56 0.50% 1/10W
R603	1-216-801-11	METAL CHIP	22 5% 1/10W	R727	1-218-662-11	METAL CHIP	56 0.50% 1/10W
R604	1-216-801-11	METAL CHIP	22 5% 1/10W	R728	1-218-662-11	METAL CHIP	56 0.50% 1/10W
R605	1-216-801-11	METAL CHIP	22 5% 1/10W	R729	1-218-662-11	METAL CHIP	56 0.50% 1/10W
R606	1-216-801-11	METAL CHIP	22 5% 1/10W	R730	1-218-709-11	METAL CHIP	5.1K 0.50% 1/10W
R607	1-216-801-11	METAL CHIP	22 5% 1/10W	R731	1-218-662-11	METAL CHIP	56 0.50% 1/10W
R608	1-216-845-11	METAL CHIP	100K 5% 1/10W	R732	1-218-709-11	METAL CHIP	5.1K 0.50% 1/10W
R609	1-216-833-11	METAL CHIP	10K 5% 1/10W	R733	1-218-662-11	METAL CHIP	56 0.50% 1/10W
R610	1-216-833-11	METAL CHIP	10K 5% 1/10W	R734	1-218-709-11	METAL CHIP	5.1K 0.50% 1/10W
				R735	1-216-864-11	SHORT CHIP	
				R736	1-216-864-11	SHORT CHIP	



REF.NO.	PART NO.	DESCRIPTION	VALUES			REF.NO.	PART NO.	DESCRIPTION	VALUES
R737	1-216-864-11	SHORT CHIP				RB704	1-234-370-21	RES, NETWORK 22X4	(1005)
R801	1-216-833-11	METAL CHIP	10K	5%	1/10W	RB705	1-234-378-21	RES, NETWORK 10KX4	(1005)
R802	1-216-833-11	METAL CHIP	10K	5%	1/10W	RB706	1-234-378-21	RES, NETWORK 10KX4	(1005)
R803	1-216-833-11	METAL CHIP	10K	5%	1/10W	RB707	1-234-378-21	RES, NETWORK 10KX4	(1005)
R804	1-216-833-11	METAL CHIP	10K	5%	1/10W	RB708	1-234-378-21	RES, NETWORK 10KX4	(1005)
R805	1-216-864-11	SHORT CHIP				RB709	1-234-371-21	RES, NETWORK 47X4	(1005)
R806	1-216-833-11	METAL CHIP	10K	5%	1/10W	RB710	1-234-371-21	RES, NETWORK 47X4	(1005)
R807	1-216-833-11	METAL CHIP	10K	5%	1/10W	RB711	1-234-371-21	RES, NETWORK 47X4	(1005)
R808	1-216-833-11	METAL CHIP	10K	5%	1/10W	RB712	1-234-371-21	RES, NETWORK 47X4	(1005)
R809	1-216-833-11	METAL CHIP	10K	5%	1/10W	RB713	1-234-378-21	RES, NETWORK 10KX4	(1005)
R810	1-216-809-11	METAL CHIP	100	5%	1/10W	RB714	1-234-378-21	RES, NETWORK 10KX4	(1005)
R811	1-216-833-11	METAL CHIP	10K	5%	1/10W	RB715	1-234-378-21	RES, NETWORK 10KX4	(1005)
R812	1-216-864-11	SHORT CHIP				RB716	1-234-378-21	RES, NETWORK 10KX4	(1005)
R813	1-216-833-11	METAL CHIP	10K	5%	1/10W	RB801	1-234-378-21	RES, NETWORK 10KX4	(1005)
R814	1-216-833-11	METAL CHIP	10K	5%	1/10W	RB802	1-234-378-21	RES, NETWORK 10KX4	(1005)
R815	1-216-833-11	METAL CHIP	10K	5%	1/10W	RB803	1-234-378-21	RES, NETWORK 10KX4	(1005)
R816	1-216-803-11	METAL CHIP	33	5%	1/10W	RB804	1-234-378-21	RES, NETWORK 10KX4	(1005)
R817	1-216-833-11	METAL CHIP	10K	5%	1/10W	RB814	1-234-378-21	RES, NETWORK 10KX4	(1005)
R818	1-216-801-11	METAL CHIP	22	5%	1/10W	RB815	1-234-378-21	RES, NETWORK 10KX4	(1005)
R820	1-216-803-11	METAL CHIP	33	5%	1/10W	RB816	1-234-378-21	RES, NETWORK 10KX4	(1005)
R821	1-218-699-11	METAL CHIP	2K	0.50%	1/10W	RB817	1-234-378-21	RES, NETWORK 10KX4	(1005)
R822	1-216-803-11	METAL CHIP	33	5%	1/10W	RB818	1-234-378-21	RES, NETWORK 10KX4	(1005)
R823	1-216-841-11	METAL CHIP	47K	5%	1/10W	RB819	1-234-378-21	RES, NETWORK 10KX4	(1005)
R824	1-216-833-11	METAL CHIP	10K	5%	1/10W	RB820	1-234-378-21	RES, NETWORK 10KX4	(1005)
R825	1-216-841-11	METAL CHIP	47K	5%	1/10W	RB821	1-234-378-21	RES, NETWORK 10KX4	(1005)
R826	1-216-841-11	METAL CHIP	47K	5%	1/10W	RB822	1-234-378-21	RES, NETWORK 10KX4	(1005)
<b>RESISTOR BRIDGE</b>									
RB601	1-234-370-21	RES, NETWORK 22X4	(1005)			RB823	1-234-378-21	RES, NETWORK 10KX4	(1005)
RB602	1-234-370-21	RES, NETWORK 22X4	(1005)			RB824	1-234-378-21	RES, NETWORK 10KX4	(1005)
RB603	1-234-370-21	RES, NETWORK 22X4	(1005)			RB825	1-234-378-21	RES, NETWORK 10KX4	(1005)
RB604	1-234-370-21	RES, NETWORK 22X4	(1005)			RB826	1-234-372-21	RES, NETWORK 100X4	(1005)
RB605	1-234-370-21	RES, NETWORK 22X4	(1005)			RB827	1-234-372-21	RES, NETWORK 100X4	(1005)
RB606	1-234-370-21	RES, NETWORK 22X4	(1005)			RB828	1-234-378-21	RES, NETWORK 10KX4	(1005)
RB607	1-234-370-21	RES, NETWORK 22X4	(1005)			RB829	1-234-378-21	RES, NETWORK 10KX4	(1005)
RB608	1-234-370-21	RES, NETWORK 22X4	(1005)			RB830	1-234-372-21	RES, NETWORK 100X4	(1005)
RB609	1-234-370-21	RES, NETWORK 22X4	(1005)			RB831	1-234-372-21	RES, NETWORK 100X4	(1005)
RB610	1-234-378-21	RES, NETWORK 10KX4	(1005)			RB832	1-234-372-21	RES, NETWORK 100X4	(1005)
RB611	1-234-378-21	RES, NETWORK 10KX4	(1005)			RB833	1-234-372-21	RES, NETWORK 100X4	(1005)
RB612	1-234-378-21	RES, NETWORK 10KX4	(1005)			RB834	1-234-372-21	RES, NETWORK 100X4	(1005)
RB613	1-234-378-21	RES, NETWORK 10KX4	(1005)			RB835	1-234-372-21	RES, NETWORK 100X4	(1005)
RB614	1-234-378-21	RES, NETWORK 10KX4	(1005)			RB836	1-234-372-21	RES, NETWORK 100X4	(1005)
RB701	1-234-370-21	RES, NETWORK 22X4	(1005)			RB837	1-234-372-21	RES, NETWORK 100X4	(1005)
RB702	1-234-370-21	RES, NETWORK 22X4	(1005)			RB838	1-234-372-21	RES, NETWORK 100X4	(1005)
RB703	1-234-370-21	RES, NETWORK 22X4	(1005)			RB839	1-234-378-21	RES, NETWORK 10KX4	(1005)



REF.NO.	PART NO.	DESCRIPTION	VALUES			REF.NO.	PART NO.	DESCRIPTION	VALUES		
RB840	1-234-378-21	RES, NETWORK 10KX4	(1005)			C7930	1-164-156-11	CERAMIC CHIP	0.1μF		25V
RB841	1-234-378-21	RES, NETWORK 10KX4	(1005)			C7931	1-164-156-11	CERAMIC CHIP	0.1μF		25V
RB842	1-234-378-21	RES, NETWORK 10KX4	(1005)			C7932	1-162-970-11	CERAMIC CHIP	0.01μF	10%	25V
						C7933	1-164-156-11	CERAMIC CHIP	0.1μF		25V
<b>CRYSTAL</b>						<b>CONNECTOR</b>					
X701	1-795-415-21	VIBRATOR, CRYSTAL				* CN7900	1-817-700-11	CONNECTOR, BOARD TO BOARD	24P		
X801	1-813-058-21	OSCILLATOR, CRYSTAL				CN7902	6-600-234-01	IC	GP1FA313TZ0F		
<b>DIODE</b>						<b>FERRITE BEAD</b>					
						D7900	8-719-046-91	DIODE	MA2S111		
						D7901	8-719-066-99	DIODE	SML-210VTT86		
						D7902	8-719-060-99	DIODE	SML-210MT-T86		
<b>IC</b>						<b>TRANSISTOR</b>					
						IC7900	8-749-925-00	IC	TK11819MTL		
						IC7903	8-759-832-05	IC	BA18BC0FP-E2		
						IC7904	8-759-475-12	IC	TC74LCX08F(EL)		
<b>CAPACITOR</b>						<b>COIL</b>					
C7901	1-128-551-11	ELECT	22μF	20%	63V	L7901	1-414-755-11	INDUCTOR	22μH		
C7902	1-162-995-11	CERAMIC CHIP	0.022μF		50V	L7902	1-410-120-11	INDUCTOR	1.2MH		
C7903	1-162-995-11	CERAMIC CHIP	0.022μF		50V	L7903	1-408-615-31	INDUCTOR	100μH		
C7904	1-126-963-11	ELECT	4.7μF	20%	50V	L7904	1-414-754-11	INDUCTOR	10μH		
C7905	1-115-339-11	CERAMIC CHIP	0.1μF	10%	50V	L7905	1-414-754-11	INDUCTOR	10μH		
C7906	1-126-964-11	ELECT	10μF	20%	50V	L7906	1-414-754-11	INDUCTOR	10μH		
C7907	1-126-933-11	ELECT	100μF	20%	16V	L7907	1-414-754-11	INDUCTOR	10μH		
C7908	1-126-933-11	ELECT	100μF	20%	16V	L7908	1-414-754-11	INDUCTOR	10μH		
C7909	1-126-935-11	ELECT	470μF	20%	16V						
C7910	1-126-964-11	ELECT	10μF	20%	50V						
C7911	1-126-933-11	ELECT	100μF	20%	16V						
C7912	1-164-156-11	CERAMIC CHIP	0.1μF		25V						
C7913	1-164-156-11	CERAMIC CHIP	0.1μF		25V						
C7914	1-164-156-11	CERAMIC CHIP	0.1μF		25V						
C7915	1-115-339-11	CERAMIC CHIP	0.1μF	10%	50V						
C7916	1-164-156-11	CERAMIC CHIP	0.1μF		25V						
C7917	1-126-947-11	ELECT	47μF	20%	35V						
C7918	1-164-156-11	CERAMIC CHIP	0.1μF		25V						
C7923	1-164-156-11	CERAMIC CHIP	0.1μF		25V						
C7924	1-164-156-11	CERAMIC CHIP	0.1μF		25V						
C7925	1-164-156-11	CERAMIC CHIP	0.1μF		25V						
C7926	1-104-665-11	ELECT	100μF	20%	25V						
C7927	1-164-156-11	CERAMIC CHIP	0.1μF		25V						
C7928	1-127-692-11	CERAMIC CHIP	10μF	10%	16V						
C7929	1-128-551-11	ELECT	22μF	20%	63V						
						R7900	1-216-821-11	METAL CHIP	1K	5%	1/10W
						R7901	1-216-845-11	METAL CHIP	100K	5%	1/10W
						R7902	1-216-821-11	METAL CHIP	1K	5%	1/10W

**QT**

Due to the complexity of this board, performing component level field repairs is not recommended. If it is determined that this board has malfunctioned, the Complete Q Box Assembly (P/N A-1606-037-A) must be replaced.

Data is provided for reference only.

**\* A-1302-541-A QT BOARD, COMPLETE**

3-739-116-01 SCREW (2X3), +PS





REF.NO.	PART NO.	DESCRIPTION	VALUES			REF.NO.	PART NO.	DESCRIPTION	VALUES		
R7903	1-216-864-11	SHORT CHIP				C7304	1-125-827-91	CERAMIC CHIP	1µF	10%	25V
R7904	1-216-864-11	SHORT CHIP				C7305	1-162-970-11	CERAMIC CHIP	0.01µF	10%	25V
R7907	1-216-833-11	METAL CHIP	10K	5%	1/10W	C7306	1-107-826-11	CERAMIC CHIP	0.1µF	10%	16V
R7908	1-216-833-11	METAL CHIP	10K	5%	1/10W	C7307	1-125-827-91	CERAMIC CHIP	1µF	10%	25V
R7909	1-216-833-11	METAL CHIP	10K	5%	1/10W	C7308	1-162-970-11	CERAMIC CHIP	0.01µF	10%	25V
R7910	1-216-833-11	METAL CHIP	10K	5%	1/10W	C7309	1-107-826-11	CERAMIC CHIP	0.1µF	10%	16V
R7927	1-216-801-11	METAL CHIP	22	5%	1/10W	C7310	1-164-156-11	CERAMIC CHIP	0.1µF		25V
R7928	1-216-801-11	METAL CHIP	22	5%	1/10W	C7311	1-164-156-11	CERAMIC CHIP	0.1µF		25V
R7930	1-216-801-11	METAL CHIP	22	5%	1/10W	C7312	1-164-156-11	CERAMIC CHIP	0.1µF		25V
R7931	1-216-809-11	METAL CHIP	100	5%	1/10W	C7313	1-164-346-11	CERAMIC CHIP	1µF		16V
R7932	1-216-809-11	METAL CHIP	100	5%	1/10W	C7314	1-164-156-11	CERAMIC CHIP	0.1µF		25V
R7934	1-216-801-11	METAL CHIP	22	5%	1/10W	C7315	1-164-346-11	CERAMIC CHIP	1µF		16V
R7935	1-216-801-11	METAL CHIP	22	5%	1/10W	C7316	1-162-962-11	CERAMIC CHIP	470pF	10%	50V
R7936	1-216-817-11	METAL CHIP	470	5%	1/10W	C7317	1-162-962-11	CERAMIC CHIP	470pF	10%	50V
R7937	1-216-841-11	METAL CHIP	47K	5%	1/10W	C7318	1-100-118-21	ELECT CHIP	82pF	20%	16V
R7938	1-216-817-11	METAL CHIP	470	5%	1/10W	C7319	1-126-206-11	ELECT CHIP	100µF	20%	6.3V
R7939	1-216-829-11	METAL CHIP	4.7K	5%	1/10W	C7320	1-100-118-21	ELECT CHIP	82pF	20%	16V
R7940	1-216-817-11	METAL CHIP	470	5%	1/10W	C7321	1-164-156-11	CERAMIC CHIP	0.1µF		25V
R7941	1-216-805-11	METAL CHIP	47	5%	1/10W	C7322	1-137-897-21	ELECT CHIP	150µF	20%	4V
R7943	1-216-805-11	METAL CHIP	47	5%	1/10W	C7323	1-137-897-21	ELECT CHIP	150µF	20%	4V
R7944	1-216-805-11	METAL CHIP	47	5%	1/10W	C7326	1-137-897-21	ELECT CHIP	150µF	20%	4V
R7945	1-216-809-11	METAL CHIP	100	5%	1/10W	C7327	1-125-837-91	CERAMIC CHIP	1µF	10%	6.3V
R7947	1-216-864-11	SHORT CHIP				C7328	1-125-837-91	CERAMIC CHIP	1µF	10%	6.3V
R7948	1-216-864-11	SHORT CHIP				C7329	1-126-206-11	ELECT CHIP	100µF	20%	6.3V
R7949	1-216-864-11	SHORT CHIP				C7330	1-126-206-11	ELECT CHIP	100µF	20%	6.3V
R7950	1-216-864-11	SHORT CHIP				C7331	1-126-206-11	ELECT CHIP	100µF	20%	6.3V
						C7332	1-164-156-11	CERAMIC CHIP	0.1µF		25V
						C7333	1-164-156-11	CERAMIC CHIP	0.1µF		25V
						C7334	1-164-156-11	CERAMIC CHIP	0.1µF		25V
						C7335	1-127-692-11	CERAMIC CHIP	10µF	10%	16V
						C7336	1-127-692-11	CERAMIC CHIP	10µF	10%	16V
						C7337	1-107-826-11	CERAMIC CHIP	0.1µF	10%	16V
						C7338	1-107-826-11	CERAMIC CHIP	0.1µF	10%	16V
						C7339	1-107-826-11	CERAMIC CHIP	0.1µF	10%	16V
						C7340	1-107-826-11	CERAMIC CHIP	0.1µF	10%	16V
						C7341	1-107-826-11	CERAMIC CHIP	0.1µF	10%	16V
						C7342	1-126-206-11	ELECT CHIP	100µF	20%	6.3V
						C7343	1-125-837-91	CERAMIC CHIP	1µF	10%	6.3V
						C7344	1-125-837-91	CERAMIC CHIP	1µF	10%	6.3V
						C7345	1-125-837-91	CERAMIC CHIP	1µF	10%	6.3V
						C7346	1-125-837-91	CERAMIC CHIP	1µF	10%	6.3V
						C7347	1-125-837-91	CERAMIC CHIP	1µF	10%	6.3V

**TUNER**

TU7900 8-598-647-00 TUNER UNIT,DIGITAL BTD-UA402SC



Due to the complexity of this board, performing component level field repairs is not recommended. If it is determined that this board has malfunctioned, the Complete Q Box Assembly (P/N A-1606-037-A) must be replaced. Data is provided for reference only.

\* A-1302-554-A QM BOARD, COMPLETE

**CAPACITOR**

C7301 1-165-811-91 CERAMIC CHIP 22µF 10% 16V  
 C7302 1-164-346-11 CERAMIC CHIP 1µF 16V  
 C7303 1-164-346-11 CERAMIC CHIP 1µF 16V



REF.NO.	PART NO.	DESCRIPTION	VALUES			REF.NO.	PART NO.	DESCRIPTION	VALUES		
C7348	1-127-692-11	CERAMIC CHIP	10μF	10%	16V	C7392	1-164-156-11	CERAMIC CHIP	0.1μF		25V
C7349	1-164-156-11	CERAMIC CHIP	0.1μF		25V	C7393	1-164-156-11	CERAMIC CHIP	0.1μF		25V
C7350	1-127-692-11	CERAMIC CHIP	10μF	10%	16V	C7394	1-127-692-11	CERAMIC CHIP	10μF	10%	16V
C7351	1-162-970-11	CERAMIC CHIP	0.01μF	10%	25V	C7395	1-164-156-11	CERAMIC CHIP	0.1μF		25V
C7352	1-162-970-11	CERAMIC CHIP	0.01μF	10%	25V	C7396	1-164-156-11	CERAMIC CHIP	0.1μF		25V
C7353	1-162-970-11	CERAMIC CHIP	0.01μF	10%	25V	C7397	1-127-692-11	CERAMIC CHIP	10μF	10%	16V
C7354	1-127-692-11	CERAMIC CHIP	10μF	10%	16V	C7398	1-164-156-11	CERAMIC CHIP	0.1μF		25V
C7355	1-164-156-11	CERAMIC CHIP	0.1μF		25V	C7399	1-125-837-91	CERAMIC CHIP	1μF	10%	6.3V
C7356	1-127-692-11	CERAMIC CHIP	10μF	10%	16V	C7400	1-162-910-11	CERAMIC CHIP	5pF	0.25pF	50V
C7357	1-164-156-11	CERAMIC CHIP	0.1μF		25V	C7401	1-164-156-11	CERAMIC CHIP	0.1μF		25V
C7358	1-164-156-11	CERAMIC CHIP	0.1μF		25V	C7402	1-164-156-11	CERAMIC CHIP	0.1μF		25V
C7359	1-164-156-11	CERAMIC CHIP	0.1μF		25V	C7403	1-164-156-11	CERAMIC CHIP	0.1μF		25V
C7360	1-164-156-11	CERAMIC CHIP	0.1μF		25V	C7404	1-162-911-11	CERAMIC CHIP	6pF	0.50pF	50V
C7361	1-164-156-11	CERAMIC CHIP	0.1μF		25V	C7405	1-164-156-11	CERAMIC CHIP	0.1μF		25V
C7362	1-164-156-11	CERAMIC CHIP	0.1μF		25V	C7406	1-164-156-11	CERAMIC CHIP	0.1μF		25V
C7363	1-164-156-11	CERAMIC CHIP	0.1μF		25V	C7407	1-162-970-11	CERAMIC CHIP	0.01μF	10%	25V
C7364	1-164-156-11	CERAMIC CHIP	0.1μF		25V	C7408	1-162-970-11	CERAMIC CHIP	0.01μF	10%	25V
C7365	1-125-837-91	CERAMIC CHIP	1μF	10%	6.3V	C7409	1-164-156-11	CERAMIC CHIP	0.1μF		25V
C7366	1-127-692-11	CERAMIC CHIP	10μF	10%	16V	C7410	1-164-156-11	CERAMIC CHIP	0.1μF		25V
C7367	1-127-692-11	CERAMIC CHIP	10μF	10%	16V	C7411	1-164-156-11	CERAMIC CHIP	0.1μF		25V
C7368	1-127-692-11	CERAMIC CHIP	10μF	10%	16V	C7412	1-164-156-11	CERAMIC CHIP	0.1μF		25V
C7369	1-127-692-11	CERAMIC CHIP	10μF	10%	16V	C7413	1-125-837-91	CERAMIC CHIP	1μF	10%	6.3V
C7370	1-127-692-11	CERAMIC CHIP	10μF	10%	16V	C7414	1-164-156-11	CERAMIC CHIP	0.1μF		25V
C7371	1-127-692-11	CERAMIC CHIP	10μF	10%	16V	C7415	1-125-837-91	CERAMIC CHIP	1μF	10%	6.3V
C7372	1-162-970-11	CERAMIC CHIP	0.01μF	10%	25V	C7416	1-125-837-91	CERAMIC CHIP	1μF	10%	6.3V
C7373	1-162-970-11	CERAMIC CHIP	0.01μF	10%	25V	C7417	1-127-692-11	CERAMIC CHIP	10μF	10%	16V
C7374	1-162-970-11	CERAMIC CHIP	0.01μF	10%	25V	C7418	1-125-837-91	CERAMIC CHIP	1μF	10%	6.3V
C7375	1-164-156-11	CERAMIC CHIP	0.1μF		25V	C7419	1-127-692-11	CERAMIC CHIP	10μF	10%	16V
C7376	1-164-156-11	CERAMIC CHIP	0.1μF		25V	C7420	1-164-156-11	CERAMIC CHIP	0.1μF		25V
C7377	1-164-156-11	CERAMIC CHIP	0.1μF		25V	C7421	1-164-156-11	CERAMIC CHIP	0.1μF		25V
C7378	1-164-156-11	CERAMIC CHIP	0.1μF		25V	C7422	1-164-156-11	CERAMIC CHIP	0.1μF		25V
C7379	1-125-837-91	CERAMIC CHIP	1μF	10%	6.3V	C7423	1-164-156-11	CERAMIC CHIP	0.1μF		25V
C7380	1-164-156-11	CERAMIC CHIP	0.1μF		25V	C7424	1-164-156-11	CERAMIC CHIP	0.1μF		25V
C7381	1-164-156-11	CERAMIC CHIP	0.1μF		25V	C7425	1-164-156-11	CERAMIC CHIP	0.1μF		25V
C7382	1-164-156-11	CERAMIC CHIP	0.1μF		25V	C7426	1-164-156-11	CERAMIC CHIP	0.1μF		25V
C7383	1-164-156-11	CERAMIC CHIP	0.1μF		25V	C7428	1-126-206-11	ELECT CHIP	100μF	20%	6.3V
C7384	1-125-837-91	CERAMIC CHIP	1μF	10%	6.3V	C7429	1-126-206-11	ELECT CHIP	100μF	20%	6.3V
C7385	1-125-837-91	CERAMIC CHIP	1μF	10%	6.3V	C7430	1-164-156-11	CERAMIC CHIP	0.1μF		25V
C7386	1-125-837-91	CERAMIC CHIP	1μF	10%	6.3V	C7431	1-164-156-11	CERAMIC CHIP	0.1μF		25V
C7387	1-164-156-11	CERAMIC CHIP	0.1μF		25V	C7432	1-127-692-11	CERAMIC CHIP	10μF	10%	16V
C7388	1-127-692-11	CERAMIC CHIP	10μF	10%	16V	C7433	1-162-970-11	CERAMIC CHIP	0.01μF	10%	25V
C7389	1-162-970-11	CERAMIC CHIP	0.01μF	10%	25V	C7434	1-162-970-11	CERAMIC CHIP	0.01μF	10%	25V
C7390	1-162-970-11	CERAMIC CHIP	0.01μF	10%	25V	C7435	1-162-970-11	CERAMIC CHIP	0.01μF	10%	25V
C7391	1-127-692-11	CERAMIC CHIP	10μF	10%	16V	C7436	1-162-970-11	CERAMIC CHIP	0.01μF	10%	25V



REF.NO.	PART NO.	DESCRIPTION	VALUES			REF.NO.	PART NO.	DESCRIPTION	VALUES		
C7437	1-164-156-11	CERAMIC CHIP	0.1μF		25V	C7482	1-162-974-11	CERAMIC CHIP	0.01μF		50V
C7438	1-164-156-11	CERAMIC CHIP	0.1μF		25V	C7483	1-164-346-11	CERAMIC CHIP	1μF		16V
C7439	1-127-692-11	CERAMIC CHIP	10μF	10%	16V	C7484	1-162-923-11	CERAMIC CHIP	47pF	5%	50V
C7440	1-162-970-11	CERAMIC CHIP	0.01μF	10%	25V	C7485	1-162-923-11	CERAMIC CHIP	47pF	5%	50V
C7441	1-162-970-11	CERAMIC CHIP	0.01μF	10%	25V	C7486	1-162-923-11	CERAMIC CHIP	47pF	5%	50V
C7442	1-162-970-11	CERAMIC CHIP	0.01μF	10%	25V	C7487	1-162-923-11	CERAMIC CHIP	47pF	5%	50V
C7443	1-162-970-11	CERAMIC CHIP	0.01μF	10%	25V	C7488	1-162-923-11	CERAMIC CHIP	47pF	5%	50V
C7444	1-164-156-11	CERAMIC CHIP	0.1μF		25V	C7489	1-162-923-11	CERAMIC CHIP	47pF	5%	50V
C7445	1-162-970-11	CERAMIC CHIP	0.01μF	10%	25V	C7491	1-124-779-00	ELECT CHIP	10μF	20%	16V
C7446	1-162-970-11	CERAMIC CHIP	0.01μF	10%	25V	C7492	1-124-779-00	ELECT CHIP	10μF	20%	16V
C7447	1-162-970-11	CERAMIC CHIP	0.01μF	10%	25V	C7494	1-162-965-11	CERAMIC CHIP	0.0015μF	10%	50V
C7448	1-162-970-11	CERAMIC CHIP	0.01μF	10%	25V	C7495	1-162-965-11	CERAMIC CHIP	0.0015μF	10%	50V
C7449	1-164-156-11	CERAMIC CHIP	0.1μF		25V	C7496	1-162-965-11	CERAMIC CHIP	0.0015μF	10%	50V
C7450	1-164-156-11	CERAMIC CHIP	0.1μF		25V	C7497	1-162-965-11	CERAMIC CHIP	0.0015μF	10%	50V
C7451	1-164-156-11	CERAMIC CHIP	0.1μF		25V	C7498	1-164-156-11	CERAMIC CHIP	0.1μF		25V
C7452	1-127-692-11	CERAMIC CHIP	10μF	10%	16V	C7499	1-164-156-11	CERAMIC CHIP	0.1μF		25V
C7453	1-162-970-11	CERAMIC CHIP	0.01μF	10%	25V	C7501	1-126-395-11	ELECT CHIP	22μF	20%	16V
C7454	1-162-970-11	CERAMIC CHIP	0.01μF	10%	25V	C7502	1-164-156-11	CERAMIC CHIP	0.1μF		25V
C7455	1-162-970-11	CERAMIC CHIP	0.01μF	10%	25V	C7503	1-164-156-11	CERAMIC CHIP	0.1μF		25V
C7456	1-162-970-11	CERAMIC CHIP	0.01μF	10%	25V	C7504	1-164-156-11	CERAMIC CHIP	0.1μF		25V
C7457	1-164-156-11	CERAMIC CHIP	0.1μF		25V	C7506	1-117-681-11	ELECT CHIP	100μF	20%	16V
C7458	1-164-156-11	CERAMIC CHIP	0.1μF		25V	C7509	1-117-681-11	ELECT CHIP	100μF	20%	16V
C7459	1-127-692-11	CERAMIC CHIP	10μF	10%	16V	C7511	1-162-974-11	CERAMIC CHIP	0.01μF		50V
C7460	1-162-970-11	CERAMIC CHIP	0.01μF	10%	25V	C7528	1-126-206-11	ELECT CHIP	100μF	20%	6.3V
C7461	1-162-970-11	CERAMIC CHIP	0.01μF	10%	25V	C7532	1-117-681-11	ELECT CHIP	100μF	20%	16V
C7462	1-162-970-11	CERAMIC CHIP	0.01μF	10%	25V	C7539	1-164-156-11	CERAMIC CHIP	0.1μF		25V
C7463	1-162-970-11	CERAMIC CHIP	0.01μF	10%	25V	C7540	1-164-156-11	CERAMIC CHIP	0.1μF		25V
C7464	1-164-156-11	CERAMIC CHIP	0.1μF		25V	C7541	1-164-156-11	CERAMIC CHIP	0.1μF		25V
C7465	1-162-970-11	CERAMIC CHIP	0.01μF	10%	25V	C7542	1-164-156-11	CERAMIC CHIP	0.1μF		25V
C7466	1-162-970-11	CERAMIC CHIP	0.01μF	10%	25V	<b>CONNECTOR</b>					
C7467	1-162-970-11	CERAMIC CHIP	0.01μF	10%	25V	* CN7300	1-816-598-11	PIN, CONNECTOR		12P	
C7468	1-162-970-11	CERAMIC CHIP	0.01μF	10%	25V	* CN7303	1-817-702-11	CONNECTOR, BOARD TO BOARD		4P	
C7469	1-164-156-11	CERAMIC CHIP	0.1μF		25V	* CN7305	1-817-717-11	CONNECTOR, BOARD TO BOARD		80P	
C7470	1-164-156-11	CERAMIC CHIP	0.1μF		25V	* CN7306	1-817-701-11	CONNECTOR, BOARD TO BOARD		24P	
C7472	1-164-156-11	CERAMIC CHIP	0.1μF		25V	* CN7308	1-817-718-11	CONNECTOR, BOARD TO BOARD		40P	
C7473	1-126-206-11	ELECT CHIP	100μF	20%	6.3V	CN7309	1-815-468-11	PIN, CONNECTOR (PC BOARD)			
C7474	1-126-206-11	ELECT CHIP	100μF	20%	6.3V	* CN7310	1-793-141-21	PIN, CONNECTOR (PC BOARD)		15P	
C7475	1-126-204-11	ELECT CHIP	47μF	20%	16V	CN7311	1-785-842-11	CONNECTOR, USB (VERTICAL TYPE)			
C7476	1-162-923-11	CERAMIC CHIP	47pF	5%	50V	<b>DIODE</b>					
C7477	1-162-923-11	CERAMIC CHIP	47pF	5%	50V	D7300	8-719-404-50	DIODE		MA111-TX	
C7478	1-162-923-11	CERAMIC CHIP	47pF	5%	50V	D7301	8-719-404-50	DIODE		MA111-TX	
C7479	1-162-923-11	CERAMIC CHIP	47pF	5%	50V	D7302	8-719-404-50	DIODE		MA111-TX	
C7480	1-162-923-11	CERAMIC CHIP	47pF	5%	50V	D7303	8-719-404-50	DIODE		MA111-TX	
C7481	1-162-923-11	CERAMIC CHIP	47pF	5%	50V						



REF.NO.	PART NO.	DESCRIPTION	VALUES	REF.NO.	PART NO.	DESCRIPTION	VALUES
D7304	8-719-404-50	DIODE	MA111-TX	IC7312	6-703-048-01	IC	XC6209B182MR
D7305	8-719-404-50	DIODE	MA111-TX	IC7313	6-703-048-01	IC	XC6209B182MR
D7306	8-719-060-99	DIODE	SML-210MT-T86	IC7314	6-703-048-01	IC	XC6209B182MR
D7308	8-719-988-61	DIODE	1SS355TE-17				
D7309	8-719-048-40	DIODE	MBRS140T3	IC7315	8-759-698-08	IC	SN74CBTLV1G125DCKR
D7310	8-719-048-40	DIODE	MBRS140T3	IC7316	8-759-694-36	IC	SN74CBTLV3257PWR
<b>FERRITE BEAD</b>				IC7317	8-759-058-54	IC	TC7S00FU(TE85R)
FB7300	1-400-089-21	FERRITE	0μH	IC7318	6-704-621-01	IC	TC58128AFT
FB7301	1-400-089-21	FERRITE	0μH	IC7319	6-704-621-01	IC	TC58128AFT
FB7302	1-469-835-21	FERRITE	0μH				
FB7303	1-500-241-22	FERRITE	0μH	IC7320	6-703-866-01	IC	M25P10-AVMN6T
FB7304	1-469-835-21	FERRITE	0μH	IC7322	6-704-849-01	IC	MT46V8M16P-6T
				IC7323	6-704-849-01	IC	MT46V8M16P-6T
FB7305	1-469-835-21	FERRITE	0μH	IC7324	6-704-849-01	IC	MT46V8M16P-6T
FB7306	1-414-229-11	FERRITE	0μH	IC7325	6-704-849-01	IC	MT46V8M16P-6T
FB7307	1-414-229-11	FERRITE	0μH				
FB7308	1-469-835-21	FERRITE	0μH	IC7326	6-702-688-01	IC	M24C64-WMN6T(B)
FB7309	1-414-229-11	FERRITE	0μH	IC7327	6-704-819-01	IC	CS4335-KSZR
				IC7330	8-759-672-72	IC	LM3526MX-H
FB7310	1-414-229-11	FERRITE	0μH	IC7335	8-759-592-47	IC	TC7SZ08FU(TE85R)
FB7311	1-414-229-11	FERRITE	0μH	IC7336	8-759-592-47	IC	TC7SZ08FU(TE85R)
FB7312	1-414-229-11	FERRITE	0μH	IC7337	8-759-592-50	IC	TC7SZ126FU(TE85R)
FB7315	1-469-835-21	FERRITE	0μH	<b>COIL</b>			
FB7317	1-400-089-21	FERRITE	0μH	L7300	1-469-349-11	INDUCTOR	1μH
				L7301	1-416-948-21	INDUCTOR	10μH
FB7318	1-400-089-21	FERRITE	0μH	L7302	1-419-491-21	INDUCTOR	10μH
FB7319	1-216-295-91	SHORT CHIP		L7303	1-414-751-11	INDUCTOR	1μH
FB7321	1-469-835-21	FERRITE	0μH	L7304	1-410-989-11	INDUCTOR	0.47μH
FB7322	1-469-835-21	FERRITE	0μH				
FB7323	1-469-835-21	FERRITE	0μH	L7305	1-410-989-11	INDUCTOR	0.47μH
<b>FILTER</b>				L7306	1-410-989-11	INDUCTOR	0.47μH
FL7300	1-781-667-22	INDUCTOR	0μH	L7307	1-410-989-11	INDUCTOR	0.47μH
<b>IC</b>				L7308	1-410-989-11	INDUCTOR	0.47μH
IC7300	6-704-629-01	IC	215H25AKA13G	L7309	1-410-989-11	INDUCTOR	0.47μH
IC7301	6-703-182-01	IC	IRU3037CS	L7312	1-414-751-11	INDUCTOR	1μH
IC7302	6-703-182-01	IC	IRU3037CS	<b>TRANSISTOR</b>			
IC7303	8-759-592-47	IC	TC7SZ08FU(TE85R)	Q7300	8-729-422-27	TRANSISTOR	2SD601A-Q
IC7304	8-759-592-47	IC	TC7SZ08FU(TE85R)	Q7301	8-729-422-27	TRANSISTOR	2SD601A-Q
				Q7302	8-729-422-27	TRANSISTOR	2SD601A-Q
IC7305	6-701-116-01	IC	TPS3823-33DBVR	Q7303	8-729-424-02	TRANSISTOR	2SB709A-QRS-TX
IC7306	8-729-044-83	TRANSISTOR	IRF7313-TR	Q7304	8-729-422-27	TRANSISTOR	2SD601A-Q
IC7307	8-729-044-83	TRANSISTOR	IRF7313-TR	Q7305	8-729-422-27	TRANSISTOR	2SD601A-Q
IC7308	8-759-538-95	IC	TC74LVX08FT(EL)	<b>RESISTOR</b>			
IC7309	6-704-622-01	IC	PQ015Y3H3ZP	R7300	1-216-864-11	SHORT CHIP	
				R7301	1-216-864-11	SHORT CHIP	
IC7310	6-703-048-01	IC	XC6209B182MR	R7303	1-216-845-11	METAL CHIP	100K 5% 1/10W
IC7311	6-703-048-01	IC	XC6209B182MR				



REF.NO.	PART NO.	DESCRIPTION	VALUES			REF.NO.	PART NO.	DESCRIPTION	VALUES		
R7304	1-216-809-11	METAL CHIP	100	5%	1/10W	R7355	1-216-801-11	METAL CHIP	22	5%	1/10W
R7305	1-216-809-11	METAL CHIP	100	5%	1/10W	R7356	1-216-857-11	METAL CHIP	1M	5%	1/10W
R7306	1-216-864-11	SHORT CHIP				R7357	1-216-801-11	METAL CHIP	22	5%	1/10W
R7307	1-216-864-11	SHORT CHIP				R7358	1-216-833-11	METAL CHIP	10K	5%	1/10W
R7308	1-218-692-11	METAL CHIP	1K	0.50%	1/10W	R7359	1-216-864-11	SHORT CHIP			
R7309	1-218-692-11	METAL CHIP	1K	0.50%	1/10W	R7360	1-216-864-11	SHORT CHIP			
R7310	1-216-801-11	METAL CHIP	22	5%	1/10W	R7361	1-216-833-11	METAL CHIP	10K	5%	1/10W
R7311	1-216-833-11	METAL CHIP	10K	5%	1/10W	R7363	1-216-833-11	METAL CHIP	10K	5%	1/10W
R7312	1-218-704-11	METAL CHIP	3.3K	0.50%	1/10W	R7364	1-216-833-11	METAL CHIP	10K	5%	1/10W
R7313	1-218-704-11	METAL CHIP	3.3K	0.50%	1/10W	R7365	1-216-833-11	METAL CHIP	10K	5%	1/10W
R7314	1-218-692-11	METAL CHIP	1K	0.50%	1/10W	R7366	1-216-833-11	METAL CHIP	10K	5%	1/10W
R7315	1-216-864-11	SHORT CHIP				R7368	1-216-833-11	METAL CHIP	10K	5%	1/10W
R7316	1-216-864-11	SHORT CHIP				R7370	1-216-833-11	METAL CHIP	10K	5%	1/10W
R7317	1-216-809-11	METAL CHIP	100	5%	1/10W	R7374	1-216-833-11	METAL CHIP	10K	5%	1/10W
R7318	1-216-837-11	METAL CHIP	22K	5%	1/10W	R7375	1-216-833-11	METAL CHIP	10K	5%	1/10W
R7319	1-216-838-11	METAL CHIP	27K	5%	1/10W	R7378	1-216-833-11	METAL CHIP	10K	5%	1/10W
R7320	1-216-864-11	SHORT CHIP				R7379	1-216-833-11	METAL CHIP	10K	5%	1/10W
R7321	1-216-809-11	METAL CHIP	100	5%	1/10W	R7381	1-216-864-11	SHORT CHIP			
R7322	1-216-801-11	METAL CHIP	22	5%	1/10W	R7382	1-216-833-11	METAL CHIP	10K	5%	1/10W
R7324	1-216-833-11	METAL CHIP	10K	5%	1/10W	R7384	1-216-833-11	METAL CHIP	10K	5%	1/10W
R7326	1-216-809-11	METAL CHIP	100	5%	1/10W	R7385	1-216-845-11	METAL CHIP	100K	5%	1/10W
R7328	1-216-833-11	METAL CHIP	10K	5%	1/10W	R7386	1-216-833-11	METAL CHIP	10K	5%	1/10W
R7329	1-216-793-11	METAL CHIP	4.7	5%	1/10W	R7387	1-216-801-11	METAL CHIP	22	5%	1/10W
R7330	1-216-793-11	METAL CHIP	4.7	5%	1/10W	R7388	1-216-833-11	METAL CHIP	10K	5%	1/10W
R7332	1-216-833-11	METAL CHIP	10K	5%	1/10W	R7389	1-216-809-11	METAL CHIP	100	5%	1/10W
R7333	1-216-864-11	SHORT CHIP				R7390	1-216-809-11	METAL CHIP	100	5%	1/10W
R7335	1-216-801-11	METAL CHIP	22	5%	1/10W	R7391	1-216-833-11	METAL CHIP	10K	5%	1/10W
R7336	1-216-821-11	METAL CHIP	1K	5%	1/10W	R7392	1-216-833-11	METAL CHIP	10K	5%	1/10W
R7337	1-216-833-11	METAL CHIP	10K	5%	1/10W	R7393	1-216-833-11	METAL CHIP	10K	5%	1/10W
R7338	1-216-833-11	METAL CHIP	10K	5%	1/10W	R7400	1-216-829-11	METAL CHIP	4.7K	5%	1/10W
R7339	1-216-809-11	METAL CHIP	100	5%	1/10W	R7401	1-218-667-11	METAL CHIP	91	0.50%	1/10W
R7340	1-216-821-11	METAL CHIP	1K	5%	1/10W	R7402	1-218-667-11	METAL CHIP	91	0.50%	1/10W
R7342	1-216-801-11	METAL CHIP	22	5%	1/10W	R7403	1-218-692-11	METAL CHIP	1K	0.50%	1/10W
R7343	1-216-801-11	METAL CHIP	22	5%	1/10W	R7404	1-218-692-11	METAL CHIP	1K	0.50%	1/10W
R7345	1-216-864-11	SHORT CHIP				R7405	1-216-801-11	METAL CHIP	22	5%	1/10W
R7346	1-216-864-11	SHORT CHIP				R7406	1-216-801-11	METAL CHIP	22	5%	1/10W
R7347	1-216-864-11	SHORT CHIP				R7407	1-216-801-11	METAL CHIP	22	5%	1/10W
R7348	1-216-864-11	SHORT CHIP				R7408	1-216-801-11	METAL CHIP	22	5%	1/10W
R7349	1-216-864-11	SHORT CHIP				R7410	1-216-801-11	METAL CHIP	22	5%	1/10W
R7350	1-216-864-11	SHORT CHIP				R7411	1-216-801-11	METAL CHIP	22	5%	1/10W
R7351	1-216-864-11	SHORT CHIP				R7413	1-216-803-11	METAL CHIP	33	5%	1/10W
R7352	1-216-864-11	SHORT CHIP				R7414	1-216-803-11	METAL CHIP	33	5%	1/10W
R7353	1-216-864-11	SHORT CHIP				R7415	1-216-803-11	METAL CHIP	33	5%	1/10W
R7354	1-216-864-11	SHORT CHIP				R7416	1-216-803-11	METAL CHIP	33	5%	1/10W
						R7417	1-216-803-11	METAL CHIP	33	5%	1/10W



REF.NO.	PART NO.	DESCRIPTION	VALUES			REF.NO.	PART NO.	DESCRIPTION	VALUES		
R7418	1-216-803-11	METAL CHIP	33	5%	1/10W	R7466	1-216-833-11	METAL CHIP	10K	5%	1/10W
R7419	1-216-803-11	METAL CHIP	33	5%	1/10W	R7468	1-216-833-11	METAL CHIP	10K	5%	1/10W
R7420	1-216-803-11	METAL CHIP	33	5%	1/10W	R7469	1-216-837-11	METAL CHIP	22K	5%	1/10W
R7421	1-216-833-11	METAL CHIP	10K	5%	1/10W	R7470	1-216-833-11	METAL CHIP	10K	5%	1/10W
R7422	1-216-825-11	METAL CHIP	2.2K	5%	1/10W	R7471	1-216-829-11	METAL CHIP	4.7K	5%	1/10W
R7423	1-216-833-11	METAL CHIP	10K	5%	1/10W	R7472	1-216-833-11	METAL CHIP	10K	5%	1/10W
R7424	1-216-825-11	METAL CHIP	2.2K	5%	1/10W	R7473	1-216-829-11	METAL CHIP	4.7K	5%	1/10W
R7425	1-216-825-11	METAL CHIP	2.2K	5%	1/10W	R7474	1-218-665-11	METAL CHIP	75	0.50%	1/10W
R7426	1-216-833-11	METAL CHIP	10K	5%	1/10W	R7475	1-216-833-11	METAL CHIP	10K	5%	1/10W
R7427	1-216-825-11	METAL CHIP	2.2K	5%	1/10W	R7476	1-216-829-11	METAL CHIP	4.7K	5%	1/10W
R7428	1-216-825-11	METAL CHIP	2.2K	5%	1/10W	R7477	1-218-665-11	METAL CHIP	75	0.50%	1/10W
R7429	1-216-809-11	METAL CHIP	100	5%	1/10W	R7478	1-218-665-11	METAL CHIP	75	0.50%	1/10W
R7430	1-216-809-11	METAL CHIP	100	5%	1/10W	R7479	1-218-665-11	METAL CHIP	75	0.50%	1/10W
R7431	1-216-825-11	METAL CHIP	2.2K	5%	1/10W	R7480	1-218-665-11	METAL CHIP	75	0.50%	1/10W
R7432	1-216-864-11	SHORT CHIP				R7481	1-218-665-11	METAL CHIP	75	0.50%	1/10W
R7433	1-216-864-11	SHORT CHIP				R7482	1-218-665-11	METAL CHIP	75	0.50%	1/10W
R7434	1-216-825-11	METAL CHIP	2.2K	5%	1/10W	R7483	1-216-833-11	METAL CHIP	10K	5%	1/10W
R7435	1-216-825-11	METAL CHIP	2.2K	5%	1/10W	R7484	1-216-850-11	METAL CHIP	270K	5%	1/10W
R7436	1-216-825-11	METAL CHIP	2.2K	5%	1/10W	R7485	1-216-850-11	METAL CHIP	270K	5%	1/10W
R7437	1-216-825-11	METAL CHIP	2.2K	5%	1/10W	R7486	1-216-833-11	METAL CHIP	10K	5%	1/10W
R7438	1-216-825-11	METAL CHIP	2.2K	5%	1/10W	R7487	1-216-833-11	METAL CHIP	10K	5%	1/10W
R7439	1-216-825-11	METAL CHIP	2.2K	5%	1/10W	R7488	1-216-818-11	METAL CHIP	560	5%	1/10W
R7440	1-216-825-11	METAL CHIP	2.2K	5%	1/10W	R7489	1-216-818-11	METAL CHIP	560	5%	1/10W
R7441	1-216-825-11	METAL CHIP	2.2K	5%	1/10W	R7490	1-216-821-11	METAL CHIP	1K	5%	1/10W
R7442	1-216-825-11	METAL CHIP	2.2K	5%	1/10W	R7491	1-216-821-11	METAL CHIP	1K	5%	1/10W
R7443	1-216-825-11	METAL CHIP	2.2K	5%	1/10W	R7493	1-216-809-11	METAL CHIP	100	5%	1/10W
R7444	1-216-825-11	METAL CHIP	2.2K	5%	1/10W	R7494	1-216-809-11	METAL CHIP	100	5%	1/10W
R7445	1-216-864-11	SHORT CHIP				R7497	1-216-821-11	METAL CHIP	1K	5%	1/10W
R7448	1-216-864-11	SHORT CHIP				R7498	1-216-821-11	METAL CHIP	1K	5%	1/10W
R7451	1-216-864-11	SHORT CHIP				R7499	1-216-821-11	METAL CHIP	1K	5%	1/10W
R7452	1-216-801-11	METAL CHIP	22	5%	1/10W	R7500	1-216-821-11	METAL CHIP	1K	5%	1/10W
R7453	1-216-801-11	METAL CHIP	22	5%	1/10W	R7501	1-216-841-11	METAL CHIP	47K	5%	1/10W
R7454	1-216-864-11	SHORT CHIP				R7502	1-216-833-11	METAL CHIP	10K	5%	1/10W
R7455	1-216-809-11	METAL CHIP	100	5%	1/10W	R7503	1-216-821-11	METAL CHIP	1K	5%	1/10W
R7456	1-216-801-11	METAL CHIP	22	5%	1/10W	R7504	1-216-864-11	SHORT CHIP			
R7457	1-216-845-11	METAL CHIP	100K	5%	1/10W	R7505	1-216-833-11	METAL CHIP	10K	5%	1/10W
R7458	1-216-845-11	METAL CHIP	100K	5%	1/10W	R7506	1-216-845-11	METAL CHIP	100K	5%	1/10W
R7459	1-216-801-11	METAL CHIP	22	5%	1/10W	R7507	1-216-845-11	METAL CHIP	100K	5%	1/10W
R7460	1-216-821-11	METAL CHIP	1K	5%	1/10W	R7508	1-216-864-11	SHORT CHIP			
R7461	1-216-845-11	METAL CHIP	100K	5%	1/10W	R7509	1-216-801-11	METAL CHIP	22	5%	1/10W
R7462	1-218-690-11	METAL CHIP	820	0.50%	1/10W	R7510	1-216-833-11	METAL CHIP	10K	5%	1/10W
R7463	1-218-690-11	METAL CHIP	820	0.50%	1/10W	R7512	1-216-864-11	SHORT CHIP			
R7464	1-218-708-11	METAL CHIP	4.7K	0.50%	1/10W	R7513	1-216-864-11	SHORT CHIP			
R7465	1-218-708-11	METAL CHIP	4.7K	0.50%	1/10W	R7514	1-216-864-11	SHORT CHIP			



REF.NO.	PART NO.	DESCRIPTION	VALUES			REF.NO.	PART NO.	DESCRIPTION	VALUES
R7515	1-216-864-11	SHORT CHIP				RB7318	1-234-370-21	RES, NETWORK 22X4	(1005)
R7516	1-216-864-11	SHORT CHIP				RB7319	1-234-370-21	RES, NETWORK 22X4	(1005)
R7517	1-216-835-11	METAL CHIP	15K	5%	1/10W	RB7320	1-234-370-21	RES, NETWORK 22X4	(1005)
R7518	1-216-835-11	METAL CHIP	15K	5%	1/10W	RB7321	1-234-370-21	RES, NETWORK 22X4	(1005)
R7519	1-216-835-11	METAL CHIP	15K	5%	1/10W	RB7322	1-234-370-21	RES, NETWORK 22X4	(1005)
R7520	1-216-835-11	METAL CHIP	15K	5%	1/10W	RB7323	1-234-370-21	RES, NETWORK 22X4	(1005)
R7543	1-216-833-11	METAL CHIP	10K	5%	1/10W	RB7324	1-234-370-21	RES, NETWORK 22X4	(1005)
R7546	1-216-864-11	SHORT CHIP				RB7325	1-234-370-21	RES, NETWORK 22X4	(1005)
R7547	1-216-864-11	SHORT CHIP				RB7326	1-234-370-21	RES, NETWORK 22X4	(1005)
R7549	1-216-801-11	METAL CHIP	22	5%	1/10W	RB7327	1-234-370-21	RES, NETWORK 22X4	(1005)
R7550	1-216-801-11	METAL CHIP	22	5%	1/10W	RB7328	1-234-370-21	RES, NETWORK 22X4	(1005)
R7551	1-216-801-11	METAL CHIP	22	5%	1/10W	RB7329	1-242-963-21	RES, NETWORK 33X4	(1005)
R7552	1-216-801-11	METAL CHIP	22	5%	1/10W	RB7330	1-242-963-21	RES, NETWORK 33X4	(1005)
R7554	1-216-809-11	METAL CHIP	100	5%	1/10W	RB7331	1-242-963-21	RES, NETWORK 33X4	(1005)
R7556	1-216-825-11	METAL CHIP	2.2K	5%	1/10W	RB7332	1-242-963-21	RES, NETWORK 33X4	(1005)
R7557	1-216-833-11	METAL CHIP	10K	5%	1/10W	RB7333	1-242-963-21	RES, NETWORK 33X4	(1005)
R7558	1-216-809-11	METAL CHIP	100	5%	1/10W	RB7334	1-242-963-21	RES, NETWORK 33X4	(1005)
R7559	1-216-833-11	METAL CHIP	10K	5%	1/10W	RB7335	1-242-963-21	RES, NETWORK 33X4	(1005)
R7562	1-216-801-11	METAL CHIP	22	5%	1/10W	RB7336	1-242-963-21	RES, NETWORK 33X4	(1005)
R7563	1-216-801-11	METAL CHIP	22	5%	1/10W	RB7337	1-242-963-21	RES, NETWORK 33X4	(1005)
R7564	1-216-864-11	SHORT CHIP				RB7338	1-242-963-21	RES, NETWORK 33X4	(1005)
R7565	1-216-864-11	SHORT CHIP				RB7339	1-242-963-21	RES, NETWORK 33X4	(1005)
R7566	1-216-864-11	SHORT CHIP				RB7340	1-242-963-21	RES, NETWORK 33X4	(1005)
R7567	1-216-864-11	SHORT CHIP				RB7341	1-242-963-21	RES, NETWORK 33X4	(1005)
R7568	1-216-864-11	SHORT CHIP				RB7342	1-242-963-21	RES, NETWORK 33X4	(1005)
R7569	1-216-864-11	SHORT CHIP				RB7343	1-242-963-21	RES, NETWORK 33X4	(1005)
R7570	1-216-864-11	SHORT CHIP				RB7344	1-242-963-21	RES, NETWORK 33X4	(1005)
R7571	1-216-864-11	SHORT CHIP				RB7345	1-234-370-21	RES, NETWORK 22X4	(1005)
R7572	1-216-864-11	SHORT CHIP				RB7346	1-234-370-21	RES, NETWORK 22X4	(1005)
R7573	1-216-864-11	SHORT CHIP				RB7347	1-234-370-21	RES, NETWORK 22X4	(1005)
<b>RESISTOR BRIDGE</b>						RB7348	1-234-370-21	RES, NETWORK 22X4	(1005)
RB7300	1-234-370-21	RES, NETWORK 22X4				RB7349	1-234-370-21	RES, NETWORK 22X4	(1005)
RB7301	1-234-370-21	RES, NETWORK 22X4				RB7350	1-234-370-21	RES, NETWORK 22X4	(1005)
RB7302	1-234-370-21	RES, NETWORK 22X4				RB7351	1-234-370-21	RES, NETWORK 22X4	(1005)
RB7303	1-234-370-21	RES, NETWORK 22X4				RB7352	1-234-370-21	RES, NETWORK 22X4	(1005)
RB7304	1-234-370-21	RES, NETWORK 22X4				RB7353	1-234-370-21	RES, NETWORK 22X4	(1005)
RB7305	1-234-370-21	RES, NETWORK 22X4				RB7354	1-234-370-21	RES, NETWORK 22X4	(1005)
RB7306	1-234-370-21	RES, NETWORK 22X4				RB7355	1-234-370-21	RES, NETWORK 22X4	(1005)
RB7307	1-234-370-21	RES, NETWORK 22X4				RB7356	1-234-370-21	RES, NETWORK 22X4	(1005)
RB7308	1-236-908-11	NETWORK RESISTOR(CHIP)	10K			RB7357	1-234-370-21	RES, NETWORK 22X4	(1005)
RB7315	1-236-908-11	NETWORK RESISTOR(CHIP)	10K			RB7360	1-234-370-21	RES, NETWORK 22X4	(1005)
RB7316	1-236-908-11	NETWORK RESISTOR(CHIP)	10K			RB7361	1-234-370-21	RES, NETWORK 22X4	(1005)
RB7317	1-234-370-21	RES, NETWORK 22X4							



REF.NO.	PART NO.	DESCRIPTION	VALUES
RB7362	1-234-370-21	RES, NETWORK 22X4	(1005)
RB7363	1-234-370-21	RES, NETWORK 22X4	(1005)
RB7364	1-234-370-21	RES, NETWORK 22X4	(1005)
RB7365	1-234-370-21	RES, NETWORK 22X4	(1005)
RB7366	1-234-370-21	RES, NETWORK 22X4	(1005)
RB7367	1-234-370-21	RES, NETWORK 22X4	(1005)
RB7368	1-234-370-21	RES, NETWORK 22X4	(1005)
RB7369	1-234-370-21	RES, NETWORK 22X4	(1005)
<b>CRYSTAL</b>			
X7300	1-579-922-11	VIBRATOR, CRYSTAL (CHIP TYPE)	
<b>HA BOARD, MOUNTED</b>			
<b>CAPACITOR</b>			
C1201	1-126-157-11	ELECT	10µF 20% 16V
<b>CONNECTOR</b>			
CN1201	1-564-525-11	PLUG, CONNECTOR	10P
<b>DIODE</b>			
D1201	8-719-061-96	DIODE	SLR-325DCT31
D1202	8-719-053-43	DIODE	SLR-325VCT31
<b>IC</b>			
IC1201	8-742-211-20	HYB IC	SBX3071-71
<b>RESISTOR</b>			
R1201	1-216-809-11	METAL CHIP	100 5% 1/10W
R1202	1-216-817-11	METAL CHIP	470 5% 1/10W
R1203	1-216-819-11	METAL CHIP	680 5% 1/10W
R1204	1-216-821-11	METAL CHIP	1K 5% 1/10W
R1205	1-216-825-11	METAL CHIP	2.2K 5% 1/10W
R1206	1-216-813-11	METAL CHIP	220 5% 1/10W
R1207	1-216-813-11	METAL CHIP	220 5% 1/10W
R1208	1-216-797-11	METAL CHIP	10 5% 1/10W
R1209	1-216-837-11	METAL CHIP	22K 5% 1/10W
<b>SWITCH</b>			
S1201	1-572-198-11	SWITCH, KEYBOARD	
S1202	1-572-198-11	SWITCH, KEYBOARD	
S1203	1-572-198-11	SWITCH, KEYBOARD	
S1204	1-572-198-11	SWITCH, KEYBOARD	
S1205	1-572-198-11	SWITCH, KEYBOARD	



Due to the complexity of this board, performing component level field repairs is not recommended. If service is required, complete board replacement is the preferred repair method. Data is provided for reference only.

**A-1302-165-A QH BOARD, COMPLETE**

**CAPACITOR**

C7203	1-162-910-11	CERAMIC CHIP	5pF	0.25pF	50V
C7204	1-162-911-11	CERAMIC CHIP	6pF	0.50pF	50V
C7205	1-162-970-11	CERAMIC CHIP	0.01µF	10%	25V
C7206	1-162-970-11	CERAMIC CHIP	0.01µF	10%	25V
C7207	1-107-826-11	CERAMIC CHIP	0.1µF	10%	16V
C7208	1-162-970-11	CERAMIC CHIP	0.01µF	10%	25V
C7209	1-125-837-91	CERAMIC CHIP	1µF	10%	6.3V
C7210	1-107-826-11	CERAMIC CHIP	0.1µF	10%	16V
C7211	1-127-760-11	CERAMIC CHIP	4.7µF	10%	6.3V
C7212	1-125-837-91	CERAMIC CHIP	1µF	10%	6.3V
C7213	1-162-970-11	CERAMIC CHIP	0.01µF	10%	25V
C7215	1-164-156-11	CERAMIC CHIP	0.1µF		25V
C7216	1-162-970-11	CERAMIC CHIP	0.01µF	10%	25V
C7217	1-125-837-91	CERAMIC CHIP	1µF	10%	6.3V
C7218	1-164-156-11	CERAMIC CHIP	0.1µF		25V
C7219	1-164-156-11	CERAMIC CHIP	0.1µF		25V
C7220	1-164-156-11	CERAMIC CHIP	0.1µF		25V
C7221	1-164-156-11	CERAMIC CHIP	0.1µF		25V
C7224	1-164-156-11	CERAMIC CHIP	0.1µF		25V

**CONNECTOR**

CN7201	1-784-010-11	CONNECTOR, USB (B)	
CN7202	1-695-915-11	TAB (CONTACT)	
CN7204	1-816-402-12	CONNECTOR, MEMORY STICK	

**DIODE**

D7201	8-719-800-76	DIODE	1SS226
D7202	8-719-083-58	DIODE	UDZSTE-173.9B
D7210	6-500-182-01	DIODE	L1503CB/ID
D7212	8-719-083-58	DIODE	UDZSTE-173.9B



QH	SR	HB
----	----	----

REF.NO.	PART NO.	DESCRIPTION	VALUES	REF.NO.	PART NO.	DESCRIPTION	VALUES
<b><u>FERRITE BEAD</u></b>				<b><u>CRYSTAL</u></b>			
FB7201	1-414-921-11	FERRITE	0μH	X7201	1-760-965-21	VIBRATOR, CRYSTAL	
FB7202	1-414-921-11	FERRITE	0μH	<b>SR</b>			
FB7203	1-414-921-11	FERRITE	0μH				
<b><u>IC</u></b>				Due to the complexity of this board, performing component level field repairs is not recommended. If service is required, complete board replacement is the preferred repair method. Data is provided for reference only.			
IC7201	6-703-076-01	IC	XC6204B332MR	<b>* A-1405-083-A SR BOARD, MOUNTED</b>			
IC7202	6-704-548-01	IC	90C36LC1B	<b><u>CONNECTOR</u></b>			
IC7203	6-700-319-01	IC	M24128-BWMN6T	<b><u>CONNECTOR</u></b>			
<b><u>COIL</u></b>				<b><u>CONNECTOR</u></b>			
L7201	1-414-394-11	INDUCTOR	2.2μH	* CN9901	1-564-506-11	PLUG, CONNECTOR	3P
<b><u>TRANSISTOR</u></b>				<b><u>DIODE</u></b>			
Q7201	8-729-424-02	TRANSISTOR	2SB709A-QRS-TX	D9901	8-719-036-94	DIODE	RD5.6SB-T1
Q7202	8-729-422-27	TRANSISTOR	2SD601A-Q	<b><u>SWITCH</u></b>			
<b><u>RESISTOR</u></b>				<b><u>SWITCH</u></b>			
R7201	1-216-864-11	SHORT CHIP		SB9901	1-477-983-11	PHOTO	SENSOR
R7202	1-414-228-11	FERRITE	0μH	<b>HB</b>			
R7203	1-216-837-11	METAL CHIP	22K 5% 1/10W				
R7204	1-216-809-11	METAL CHIP	100 5% 1/10W	<b>* A-1405-071-A HB BOARD, MOUNTED</b>			
R7206	1-216-857-11	METAL CHIP	1M 5% 1/10W	<b><u>CAPACITOR</u></b>			
R7209	1-414-228-11	FERRITE	0μH	C1100	1-126-960-11	ELECT	1μF 20% 50V
R7210	1-216-803-11	METAL CHIP	33 5% 1/10W	C1101	1-126-960-11	ELECT	1μF 20% 50V
R7211	1-216-821-11	METAL CHIP	1K 5% 1/10W	<b><u>CONNECTOR</u></b>			
R7212	1-216-803-11	METAL CHIP	33 5% 1/10W	* CN1101	1-564-526-11	PLUG, CONNECTOR	11P
R7214	1-216-823-11	METAL CHIP	1.5K 5% 1/10W	<b><u>DIODE</u></b>			
R7215	1-414-228-11	FERRITE	0μH	D1100	8-719-070-17	DIODE	NNCD10A-T1
R7216	1-216-821-11	METAL CHIP	1K 5% 1/10W	D1101	8-719-070-17	DIODE	NNCD10A-T1
R7217	1-216-821-11	METAL CHIP	1K 5% 1/10W	D1103	8-719-070-17	DIODE	NNCD10A-T1
R7218	1-218-708-11	METAL CHIP	4.7K 0.50% 1/10W	<b><u>JACK</u></b>			
R7219	1-218-708-11	METAL CHIP	4.7K 0.50% 1/10W	J1101	1-770-361-11	TERMINAL BLOCK, S	
R7221	1-216-821-11	METAL CHIP	1K 5% 1/10W	<b><u>RESISTOR</u></b>			
R7222	1-216-811-11	METAL CHIP	150 5% 1/10W	R1100	1-247-895-91	CARBON	470K 5% 1/4W
R7223	1-216-809-11	METAL CHIP	100 5% 1/10W	R1101	1-247-895-91	CARBON	470K 5% 1/4W
R7224	1-216-809-11	METAL CHIP	100 5% 1/10W	R1102	1-247-804-11	CARBON	75 5% 1/4W
R7225	1-216-809-11	METAL CHIP	100 5% 1/10W				
R7226	1-216-864-11	SHORT CHIP					
R7227	1-216-864-11	SHORT CHIP					
R7228	1-216-864-11	SHORT CHIP					
R7229	1-216-821-11	METAL CHIP	1K 5% 1/10W				
R7231	1-216-825-11	METAL CHIP	2.2K 5% 1/10W				



REF.NO.	PART NO.	DESCRIPTION	VALUES			REF.NO.	PART NO.	DESCRIPTION	VALUES
R1103	1-247-804-11	CARBON	75	5%	1/4W	*	4-094-652-01	CUSHION, UPPER (KDP-51WS550 ONLY)	
R1106	1-249-417-11	CARBON	1K	5%	1/4W	*	4-094-656-01	CUSHION, UPPER (KDP-57WS550 ONLY)	
R1107	1-247-804-11	CARBON	75	5%	1/4W	*	4-094-660-01	CUSHION, UPPER (KDP-65WS550 ONLY)	
<b><u>ACCESSORIES AND PACKING</u></b>									
*	4-041-426-01	BAG, PROTECTION (KDP-51WS550 ONLY)					4-094-487-11	MANUAL, INSTRUCTION	
*	4-076-420-01	BAG, PROTECTION (KDP-57WS550/65WS550 ONLY)					4-094-487-21	MANUAL, INSTRUCTION	
*	3-337-402-01	BAND, BINDING					4-094-487-31	MANUAL, INSTRUCTION	
*	4-094-817-01	CARTON, INDIVIDUAL (KDP-51WS550 ONLY)				*	4-042-463-01	SHEET, PROTECTION	
*	4-094-818-01	INDIVIDUAL CARTON (KDP-57WS550 ONLY)				*	4-094-659-01	TRAY (KDP-57WS550 ONLY)	
*	4-094-812-01	INDIVIDUAL CARTON (KDP-65WS550 ONLY)				*	4-094-663-01	TRAY (KDP-65WS550 ONLY)	
*	4-094-664-01	CUSHION, LOWER (KDP-51WS550 ONLY)					1-827-516-11	USB CABLE	
*	4-094-665-01	CUSHION, LOWER (KDP-57WS550 ONLY)				<b><u>REMOTE COMMANDER</u></b>			
*	4-094-666-01	CUSHION, LOWER (KDP-65WS550 ONLY)				1-468-764-11	REMOTE COMMANDER (RM-Y192)		
						4-081-888-01	BATTERY COVER (FOR RM-Y192)		

*In an effort to reduce the size of this pdf file the tiled schematics are not attached to this Service Manual. To receive a complete set of the tiled schematics for this manual please submit a request to Nita Wardlaw at [nita.wardlaw@am.sony.com](mailto:nita.wardlaw@am.sony.com).*

**SONY**

4-094-487-11



# **High Definition Projection TV**

**Operating Instructions**

© 2003 Sony Corporation



MEMORY STICK™

**KDP-51WS550 KDP-57WS550  
KDP-65WS550**

## Owner's Record

The model and serial numbers are located at the rear of the projection TV, below the Sony logo, on the sticker, and also on the TV box (white label). Record these numbers in the spaces provided below. Refer to them whenever you call upon your Sony dealer regarding this product.

Model No. \_\_\_\_\_

Serial No. \_\_\_\_\_

## WARNING

To reduce the risk of fire or electric shock, do not expose this apparatus to rain or moisture.



This symbol is intended to alert the user to the presence of uninsulated "dangerous voltage" within the product's enclosure that may be of sufficient magnitude to constitute a risk of electric shock to persons.



This symbol is intended to alert the user to the presence of important operating and maintenance (servicing) instructions in the literature accompanying the appliance.

Do not expose the TV to dripping or splashing. Avoid placing liquid-filled objects, such as vases, on top of the TV.

## CAUTION

To prevent electric shock, do not use this polarized AC plug with an extension cord, receptacle or other outlet unless the blades can be fully inserted to prevent blade exposure.

## CAUTION

When using Video games, computers, and similar products with your projection TV, or viewing a TV station whose logo always stays on the screen, keep the brightness and picture functions at low settings. If a fixed (non-moving) pattern such as a station logo is left on the screen for long periods of time, especially at a high brightness or picture setting, the image can be permanently imprinted onto the screen. These types of imprints are known as image retention.

## CAUTION

How to reduce the risk of "Image Retention" on your Projection TV

Bright, stationary images such as TV station logos displayed on your TV can cause permanent damage to your TV, resulting in retention of the image in the picture. Please take the following steps to reduce the risk of causing image retention:

View a variety of program sources or programming material.

Image retention can occur when bright stationary images such as TV station logos are viewed. Changing the program material viewed reduces the possibility that a single image will become imprinted on the picture tubes in your TV.

When viewing programs with stationary images, adjust the picture setting to reduce the "Picture" and "Brightness" levels. Image retention is accelerated by higher "Brightness" and higher "Picture" settings.

Please see page 92 for instructions on adjusting picture settings.

This will help you reduce the risk of causing image retention.

**IMAGE RETENTION IS NOT COVERED BY YOUR WARRANTY**

## Note on Caption Vision

This television receiver provides display of television closed captioning in accordance with §15.119 of the FCC rules.

## Note on Convergence Adjustment

Before you use your projection TV, make sure to adjust convergence. For details, see "Adjusting the Convergence Automatically (Flash Focus)" on page 42.

Use of this television receiver for other than private viewing of programs broadcast on UHF or VHF or transmitted by cable companies for the use of the general public may require authorization from the broadcaster/cable company and/or program owner.

## NOTIFICATION

This equipment has been tested and found to comply with the limits for a Class B digital device, pursuant to Part 15 of the FCC Rules. These limits are designed to provide reasonable protection against harmful interference in a residential installation. This equipment generates, uses, and can radiate radio frequency energy and, if not installed and used in accordance with the instructions, may cause harmful interference with radio communications. However, there is no guarantee that interference will not occur in a particular installation. If this equipment does cause harmful interference to radio or television reception, which can be determined by turning the equipment off and on, the user is encouraged to try to correct the interference by one or more of the following measures:

- Reorient or relocate the receiving antenna.
- Increase the separation between the equipment and receiver.
- Connect the equipment into an outlet on a circuit different from that to which the receiver is connected.
- Consult the dealer or an experienced radio/TV technician for help.

You are cautioned that any changes or modifications not expressly approved in this manual could void your authority to operate this equipment.

## Safety

- Operate the projection TV only on 120 V AC.
- The plug is designed, for safety purposes, to fit into the wall outlet only one way. If you are unable to insert the plug fully into the outlet, contact your dealer.
- If any liquid or solid object should fall inside the cabinet, unplug the projection TV immediately and have it checked by qualified service personnel before operating it further.
- If you will not be using the projection TV for several days, disconnect the power by pulling the plug itself. Never pull on the cord.
- For details concerning safety precautions, see "Important Safety Instructions" on page 3.

## Installing

- To prevent internal heat buildup, do not block the ventilation openings.
- Do not install the projection TV in a hot or humid place, or in a place subject to excessive dust or mechanical vibration.
- Avoid operating the projection TV at temperatures below 5°C (41°F).
- If the projection TV is transported directly from a cold to a warm location, or if the room temperature changes suddenly, the picture may be blurred or show poor color due to moisture condensation. In this case, please wait a few hours to let the moisture evaporate before turning on the projection TV.

- To obtain the best picture, do not expose the screen to direct illumination or direct sunlight. It is recommended to use spot lighting directed down from the ceiling or to cover the windows that face the screen with opaque drapery. It is desirable to install the projection TV in a room where the floor and walls are not of a reflective material.

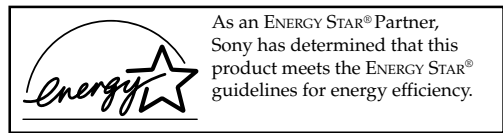

ENERGY STAR® is a U.S. registered mark.

## Trademark Information

TruSurround and the  symbol are trademarks of SRS Labs, Inc. TruSurround technology is incorporated under license from SRS Labs, Inc.

BBE and BBE Symbol are trademarks of BBE Sound, Inc. and are licensed by BBE Sound, Inc. under U.S. Patent No. 4,638,258 and 4,482,866.

Steady Sound, Digital Reality Creation, Caption Vision, CineMotion, Memory Stick, and Twin View are registered trademarks of Sony Corporation. ClearEdge VM, HD Detailer, and Uniform Brightness Screen are trademarks of Sony Corporation. i.LINK is a trademark of Sony Corporation and used only to designate that a product contains an IEEE 1394 connector. All products with an i.LINK connector may not communicate with each other.

## For Safety

### Be careful when moving the projection TV

When you place the projection TV in position, be careful not to drop it on your foot or fingers.

Watch your footing while installing the projection TV.

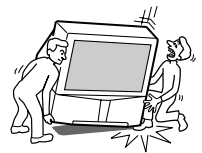

### Carry the projection TV in the specified manner

If you carry the projection TV in a manner other than the specified manner and without the specified number of persons, it may drop and a serious injury may be caused. Be sure to follow the instructions mentioned below.

- Carry the projection TV with the specified number of persons (see "Carrying Your Projection TV" on page 12).
- Do not carry the projection TV holding the speaker grill.
- Hold the projection TV tightly when carrying it.

The projection TV includes handles that you can use to carry the unit (KDP-65WS550 only).

# Important Safety Instructions

- 1 Read these instructions.
- 2 Keep these instructions.
- 3 Heed all warnings.
- 4 Follow all instructions.
- 5 Do not use this apparatus near water.
- 6 Clean only with dry cloth.
- 7 Do not block any ventilation openings. Install in accordance with the manufacturer's instructions.
- 8 Do not install near any heat sources such as radiators, heat registers, stoves, or other apparatus (including amplifiers) that produce heat.
- 9 Do not defeat the safety purpose of the polarized or grounding-type plug. A polarized plug has two blades with one wider than the other. A grounding type plug has two blades and a third grounding prong. The wide blade or the third prong are provided for your safety. If the provided plug does not fit into your outlet, consult an electrician for replacement of the obsolete outlet.
- 10 Protect the power cord from being walked on or pinched particularly at plugs, convenience receptacles, and the point where they exit from the apparatus.
- 11 Only use attachments/accessories specified by the manufacturer.
- 12 Use only with the cart, stand, tripod, bracket, or table specified by the manufacturer, or sold with the apparatus. When a cart is used, use caution when moving the cart/apparatus combination to avoid injury from tip-over.
- 13 Unplug this apparatus during lightning storms or when unused for long periods of time.
- 14 Refer all servicing to qualified service personnel. Servicing is required when the apparatus has been damaged in any way, such as power-supply cord or plug is damaged, liquid has been spilled or objects have fallen into the apparatus, the apparatus has been exposed to rain or moisture, does not operate normally, or has been dropped.



## Additional Cleaning Instructions

Clean the cabinet of the projection TV with a dry, soft cloth. To clean the screen of your projection TV, please use only a clean, soft cloth lightly dampened with water. Stubborn stains such as fingerprints can be removed with a clean, soft cloth lightly dampened with a solution of mild soap and warm water. Never use alcohol or strong solvents (such as thinner, benzene, ammonia, or alcohol-based), or abrasive cleaning solutions to clean your TV screen.

If the picture becomes dark after using the projection TV for a long period of time, it may be necessary to clean the inside of the projection TV. Consult qualified service personnel.





# Contents

## ***Introducing the Digital Projection TV***

<b><i>Welcome</i></b> .....	<b>9</b>
Package Contents .....	9
Features .....	9

## ***Setting Up the Digital Projection TV***

<b><i>Overview</i></b> .....	<b>11</b>
<b><i>Carrying Your Projection TV</i></b> .....	<b>12</b>
<b><i>Installing the TV</i></b> .....	<b>12</b>
<b><i>TV Controls and Connectors</i></b> .....	<b>13</b>
Front Video Controls .....	13
Front Panel .....	14
Rear Panel .....	16
<b><i>Basic Connections: Connecting a Cable or Antenna</i></b> .....	<b>18</b>
Cable or Antenna Only .....	19
Cable and Antenna Only .....	20
Cable Box and Cable Only .....	21
Cable Box Only .....	22
<b><i>Connecting Optional Equipment</i></b> .....	<b>23</b>
About Using S VIDEO .....	23
VCR and Cable .....	24
VCR and Cable Box .....	26
Two VCRs for Tape Editing .....	28
Satellite Receiver .....	30
Satellite Receiver and VCR .....	32
DVD Player with Component Video Connectors .....	34
DVD Player with S VIDEO and Audio Connectors .....	36
Camcorder .....	37
Audio Receiver .....	38
<b><i>Connecting a Device with an Optical IN Connector</i></b> .....	<b>39</b>
<b><i>Using the CONTROL S Feature</i></b> .....	<b>40</b>
<b><i>Setting Up the Channel List</i></b> .....	<b>41</b>
Using Auto Program .....	41
<b><i>Adjusting the Convergence Automatically (Flash Focus)</i></b> .....	<b>42</b>
Notes on Flash Focus .....	42
<b><i>Adjusting the Convergence Manually</i></b> .....	<b>43</b>
Notes on Adjusting the Convergence Manually .....	44

## **Using the Remote Control**

<b>Overview</b> .....	<b>45</b>
<b>Inserting Batteries</b> .....	<b>45</b>
<b>Button Descriptions</b> .....	<b>46</b>
Outside Panel .....	46
Inside Panel .....	48
<b>Programming the Remote Control</b> .....	<b>49</b>
<b>Using Other Equipment with Your TV Remote Control</b> .....	<b>51</b>
All Equipment.....	51
Operating a VCR .....	51
Operating a Satellite Receiver .....	51
Operating a Cable Box.....	52
Operating a DVD Player .....	52
Operating an MDP (Laserdisc Player) .....	52

## **Using the Features**

<b>Overview</b> .....	<b>53</b>
<b>Watching TV</b> .....	<b>54</b>
<b>Using the Scrolling Index</b> .....	<b>55</b>
Factors Affecting Scrolling Index .....	55
<b>Using Wide Mode</b> .....	<b>56</b>
<b>Using Twin View</b> .....	<b>57</b>
Displaying Twin Pictures .....	57
Factors Affecting Twin View .....	57
Activating the Picture .....	58
Changing the Picture Size.....	59
<b>Using Favorite Channels</b> .....	<b>60</b>
Creating a List of Favorite Channels.....	60
Displaying a List of Favorite Channels .....	60
<b>Using the Freeze Function</b> .....	<b>61</b>

## **Using the Digital Program Guide**

<b>Displaying the Digital Program Guide</b> .....	<b>63</b>
Navigating the Digital Program Menus.....	64
Using the Guide Menu .....	64
Using the Program Options Menu.....	64
Using the Caption Vision Menu .....	65
Using the Digital Setup Menu .....	65
Customizing Caption Vision.....	66

## Using the Memory Stick Viewer

<b>About Memory Stick</b> .....	<b>67</b>
Features .....	67
Memory Stick Compatibility.....	68
File Compatibility.....	68
Trademark Information.....	68
<b>Inserting and Removing a Memory Stick</b> .....	<b>69</b>
Inserting a Memory Stick .....	69
Inserting the Memory Stick Duo.....	70
Removing a Memory Stick .....	71
<b>Using the Memory Stick Index</b> .....	<b>72</b>
Using the Memory Stick Index .....	73
<b>Viewing Photos</b> .....	<b>74</b>
Photo Controls .....	74
Photo Menu Bar Options .....	75
Using Zoom and Pan .....	76
Using Rotate.....	76
<b>Playing Movies</b> .....	<b>77</b>
Movie Controls.....	77
Movie Menu Bar Options.....	78
<b>Memory Stick Index Menu Bar Options</b> .....	<b>79</b>
Slide Show Menu Options .....	79
Folder Menu Options.....	80
Memory Stick Menu .....	80
<b>Notes on Using Memory Stick Media</b> .....	<b>81</b>
About DCF File Names.....	81
Memory Stick Precautions.....	82

## Using i.LINK

<b>About i.LINK</b> .....	<b>83</b>
Using i.LINK Cables.....	83
Connecting i.LINK Devices .....	84
<b>Selecting an i.LINK Device</b> .....	<b>86</b>
<b>Using the i.LINK Control Panel</b> .....	<b>87</b>
Notes About Controlling i.LINK Devices .....	88
<b>i.LINK Setup</b> .....	<b>89</b>
Notes on i.LINK.....	89

## **Using the Menus**

<b>Overview .....</b>	<b>91</b>
<b>Navigating Through Menus .....</b>	<b>91</b>
<b>Using the Video Menu .....</b>	<b>92</b>
<b>Using the Audio Menu .....</b>	<b>94</b>
<b>Using the Screen Menu .....</b>	<b>96</b>
<b>Using the Channel Menu .....</b>	<b>98</b>
<b>Using the Parent Menu .....</b>	<b>100</b>
<b>Using the Setup Menu .....</b>	<b>103</b>

## **Other Information**

<b>Overview .....</b>	<b>107</b>
<b>Glossary .....</b>	<b>108</b>
<b>Contacting Sony .....</b>	<b>109</b>
<b>Troubleshooting .....</b>	<b>109</b>
Twin View .....	109
Remote Control .....	110
Channels .....	110
Memory Stick .....	111
Audio .....	112
Video .....	113
General .....	114
<b>Specifications .....</b>	<b>115</b>
<b>Optional Accessories .....</b>	<b>116</b>
<b>Index .....</b>	<b>117</b>

# Introducing the Digital Projection TV

## Welcome

This chapter describes the contents of the package in which the TV is shipped and provides an overview of the features of your Digital Projection TV.

---

## Package Contents

Along with your new projection TV, the package contains a remote control and two AA batteries. No additional cables are included. These items are all you need to set up and operate the projection TV in its basic configuration.

Most components (VCRs, DVD players, etc.) come with the necessary cables to connect them. If you want to set up a complex system, you may need to buy extra cables, connectors, etc. Be sure to have these on hand before you start to connect your system.

---

## Features

Some of the features that you will enjoy with your new TV include:

- ❑ **Built-in Digital Television Receiver:** You can watch digital television programs and enjoy the improved audio/video quality offered by these programs.
- ❑ **Wide Screen Mode:** Watch conventional 4:3 aspect ratio broadcasts in wide screen (16:9) mode.
- ❑ **High Definition Signal Reception:** Watch TV signals broadcast in HDTV for the clearest possible broadcast picture.
- ❑ **DRC® (Digital Reality Creation) Multifunction V1:** Unlike conventional line doublers, the DRC Multifunction feature replaces the signal's NTSC waveform with the near-HD equivalent, while doubling the number of vertical and horizontal lines. This results in four times the density for quality sources, such as DVD, satellite, and digital camcorders. The Video Menu allows you to select interlaced, progressive, or CineMotion™ output. The DRC Palette option lets you customize the level of detail (Reality) and smoothness (Clarity) to create up to three custom palettes.
- ❑ **Scrolling Index:** Lets you select programs from a series of preview windows that scroll along the right side of the screen.
- ❑ **Favorite Channels:** Allows you to preview and select from sixteen of your favorite channels.

- ❑ **Twin View™**: Using the Multi-Image Driver (MIDX), Twin View allows you to watch two programs side by side, with the ability to zoom in one picture. You can watch pictures from two different sources (1080i, 720p, 480p, and 480i) simultaneously. (Only the left Twin View window can display 1080i, 720p, and 480p sources.)
- ❑ **ClearEdge VM™ Velocity Modulation**: Sharpens picture definition by enhancing vertical lines.
- ❑ **Steady Sound®**: Equalizes volume levels so there is consistent output between programs and commercials.
- ❑ **Memory Stick® Viewer**: Lets you watch digital photo (JPEG) and movie (MPEG1) files that are stored on Memory Stick media.
- ❑ **Component Video Inputs**: Offers the best video quality for DVD (480p, 480i), and digital set-top box (HD1080i, 720p) connections.
- ❑ **HD Detailer™**: Wideband video amplifier has a high bandwidth frequency rating, which allows it to send more video information to the screen, resulting in finer picture quality, especially for HD sources.
- ❑ **CineMotion™**: Reverse 3-2 pulldown processing provides optimal picture quality for film-based sources (media originally shot in 24 frames-per-second format).
- ❑ **Parental Control**: V-Chip technology allows parents to block unsuitable programming from younger viewers.
- ❑ **Digital Visual Interface (DVI)**: Can accommodate a copy-protected digital connection (HDCP\*) to other devices (such as digital set-top boxes) that have compatible interfaces. The DVI-HDTV input terminal is compliant with the EIA-861 standard and is not intended for use with personal computers.
- ❑ **i.LINK**: Provides a secure digital interface to other digital home entertainment devices. i.LINK allows for the secure transfer of copyright-protected high-definition content between these devices and your digital projection television.

---

\*High-bandwidth Digital Content Protection

# Setting Up the Digital Projection TV

## Overview

This chapter includes illustrated instructions for setting up your TV.

<i>Topic</i>	<i>Page(s)</i>
Carrying Your Projection TV	12
Installing the TV	12
TV Controls and Connectors	13-17
Basic Connections: Connecting a Cable or Antenna	18-22
Connecting Optional Equipment	
VCR and Cable	24
VCR and Cable Box	26
Two VCRs for Tape Editing	28
Satellite Receiver	30
Satellite Receiver and VCR	32
DVD Player with Component Video Connectors	34
DVD Player with S VIDEO and Audio Connectors	36
Camcorder	37
Audio Receiver	38
Connecting a Device with an Optical IN Connector	39
Using the CONTROL S Feature	40
Setting Up the Channel List	41
Adjusting the Convergence Automatically (Flash Focus)	42
Adjusting the Convergence Manually (Manual Convergence)	43

## Carrying Your Projection TV

Carrying the TV requires four or more people. The TV is equipped with casters for easy movement on a hard surface. Be sure to move your projection TV using the casters. The TV includes handles that you can use to carry the unit (KDP-65WS550 only).

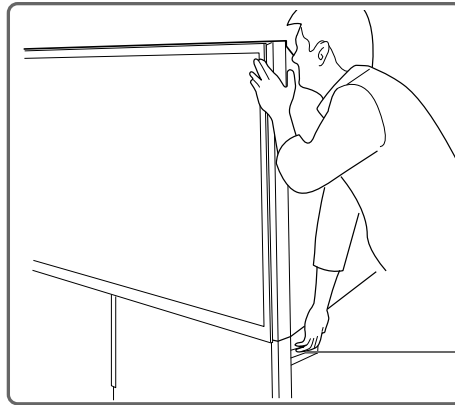

Handle (one on each side)  
(KDP-65WS550 only)

## Installing the TV

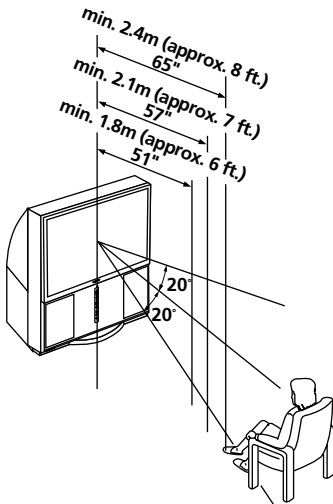

Recommended Vertical Viewing Angle

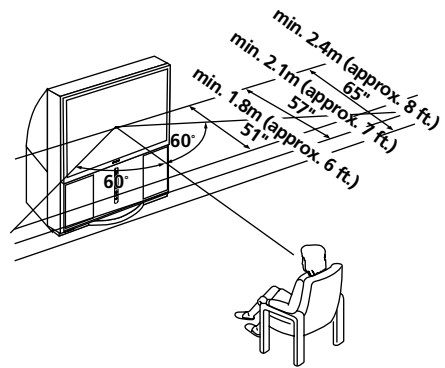

Recommended Horizontal Viewing Angle



## TV Controls and Connectors

To access the front video panel, push up and then release. The panel drops down automatically.

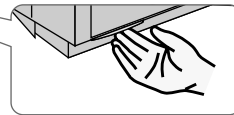
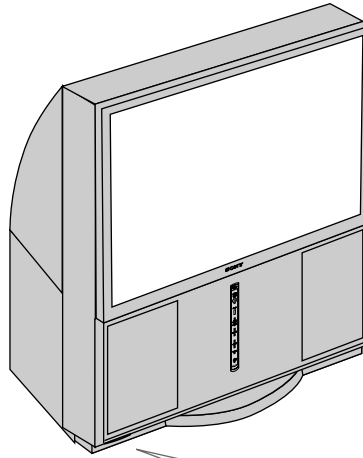

Push up  
and release

### Front Video Controls

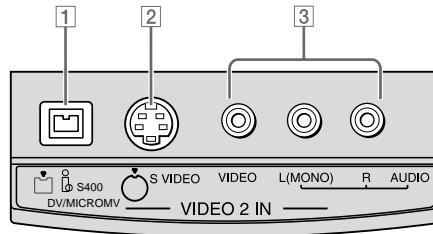

- |   |   |
|---|---|
| <b>1</b> i.LINK                                     | Connects to the i.LINK jack on your i.LINK-compatible portable device. Provides a secure digital connection between your TV and your i.LINK-compatible portable device. |
| <b>2</b> S VIDEO<br>VIDEO 2 INPUT                   | Connects to the S VIDEO OUT jack on your camcorder or other video equipment that has S VIDEO. Provides better picture quality than composite video ( <b>3</b> ).        |
| <b>3</b> VIDEO/L(MONO)-<br>AUDIO-R<br>VIDEO 2 INPUT | Connects to the composite A/V output jacks on your camcorder or other video equipment.  |

# Front Panel

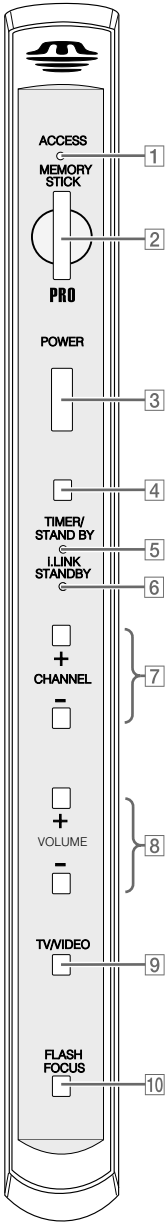

<i>Item</i>	<i>Description</i>
1 MEMORY STICK ACCESS LED	When lit, indicates that the Memory Stick is being read. (Do not remove the Memory Stick when the indicator is lit.)
2 MEMORY STICK	Memory Stick insertion slot. For details, see “Inserting and Removing a Memory Stick” on page 69.
3 POWER	Press to turn on and off the TV.
4 Infrared Receiver (IR)	Receives IR signals from the TV’s remote control.
5 TIMER/STAND BY LED	When lit, indicates one of the timers is set. When the timer is set, this LED will remain lit even if the TV is turned off. For details, see page 104.
6 i.LINK STANDBY LED	When lit in orange, indicates that i.LINK Standby is on. For details, see page 105.
7 -CHANNEL+	Press to scan through channels. To scan quickly through channels, press and hold down either CHANNEL button.
8 -VOLUME +	Press to adjust the volume.
9 TV/VIDEO	Press repeatedly to cycle through the video equipment connected to the TV’s video inputs.
10 FLASH FOCUS	Press to adjust the convergence (see page 42).

# Rear Panel

Setup

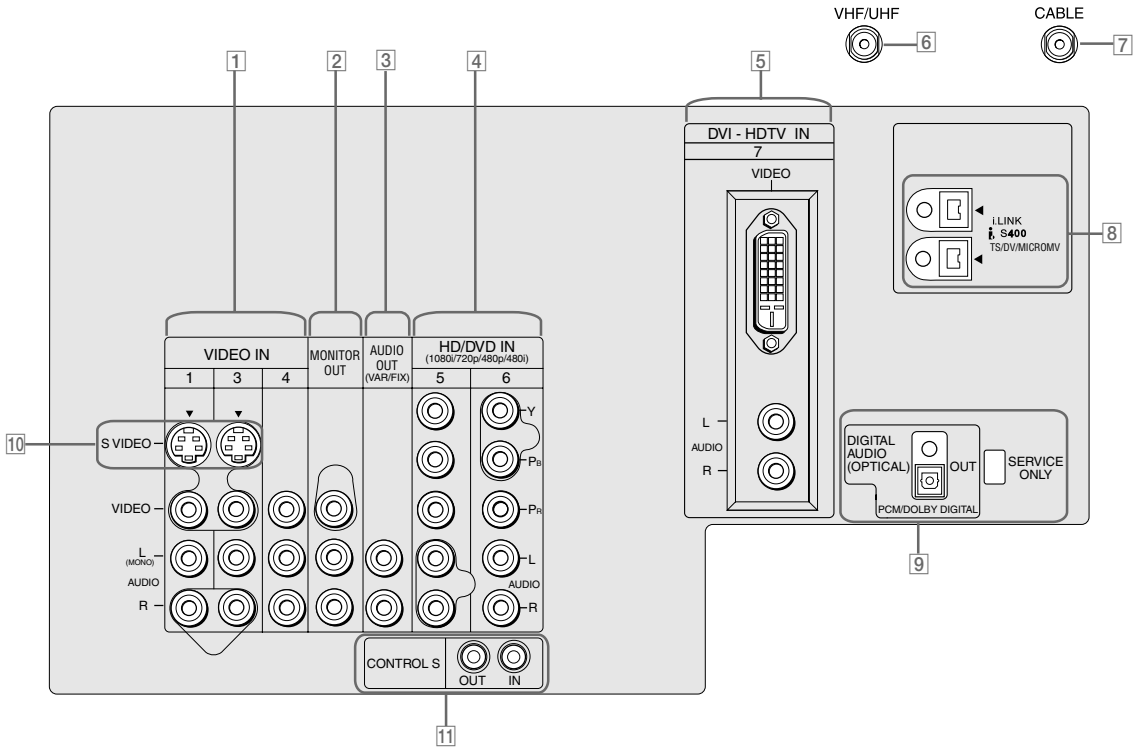

Jack	Description
<b>1</b> VIDEO IN 1/3/4 VIDEO/L(MONO) -AUDIO-R	Connect to the composite A/V output jacks on your VCR or other video component. A fourth component A/V input jack (VIDEO 2) is located on the front panel of the TV. These video connections provide better picture quality than the VHF/UHF ( <b>6</b> ) connections.
<b>2</b> MONITOR OUT	Lets you record the program you are watching to a VCR. When two VCRs are connected, you can use the TV as a monitor for tape-to-tape editing (not available with 480p, 720p, or 1080i when the input is set to VIDEO 5-7).
<b>3</b> AUDIO OUT (VAR/FIX) L (MONO)/R	Connects to the left and right audio input jacks of your audio or video equipment. You can use these outputs to listen to your TV's audio through your stereo system.
<b>4</b> HD/DVD IN 5/6 (1080i/720p/480p/480i)	Connect to your DVD player's or digital set-top box's component video (Y, PB, PR) and audio (L/R) jacks. Component video provides better picture quality than <b>1</b> , <b>6</b> , or <b>10</b> ).
<b>5</b> DVI-HDTV VIDEO AUDIO R/L (VIDEO 7 IN)	Can accommodate a copy-protected digital connection (HDCP*) to other devices (such as digital set-top boxes) that have compatible interfaces. The DVI-HDTV input terminal is compliant with the EIA-861 standard and is not intended for use with personal computers. See the instruction manual that came with your equipment for details about connecting and using it with the TV.
<b>6</b> VHF/UHF	RF input that connects to your VHF/UHF antenna or cable box.
<b>7</b> Cable	RF input that connects to your cable signal.
<b>8</b> i.LINK	Used for connecting i.LINK-equipped devices.
<b>9</b> DIGITAL AUDIO OPTICAL OUTPUT (DOLBY DIGITAL PCM)	Connect to the optical audio input of an audio component that is Dolby Digital and PCM compatible.
<b>10</b> S VIDEO IN 1/3	Connects to the S VIDEO OUT jack of your VCR or other video equipment that has S VIDEO. S VIDEO provides better picture quality than either composite video ( <b>1</b> ) or VHF/UHF ( <b>6</b> ) connections.
<b>11</b> CONTROL S IN/OUT	Allows the TV to receive (IN) and send (OUT) remote control signals to other Sony infrared-controlled audio or video equipment that has the CONTROL S function.

\*High-bandwidth Digital Content Protection

## Basic Connections: Connecting a Cable or Antenna

The way in which you will connect your TV varies, depending on how your home receives a signal (cable, cable box, antenna) and whether or not you plan to connect a VCR.

<i>If You Are Connecting</i>	<i>See Page</i>
<b>Cable or Antenna Only</b>	19
<input type="checkbox"/> No cable box or VCR	
<b>Cable and Antenna Only</b>	20
<input type="checkbox"/> No cable box or VCR	
<b>Cable Box and Cable Only</b>	21
<input type="checkbox"/> Cable box unscrambles only some channels (usually premium channels)	
<input type="checkbox"/> No VCR	
<b>Cable Box Only</b>	22
<input type="checkbox"/> Cable box unscrambles all channels	
<input type="checkbox"/> No VCR	

### If you are connecting a VCR

- See the connections described on pages 24 and 26.

## Cable or Antenna Only

For best results, use one of the following connections if you are connecting a cable or an antenna and you:

- ❑ Do not need a cable box to unscramble channels. (If you have a cable box, see pages 21-22.)
- ❑ Do not intend to connect a VCR. (If you have a VCR, see pages 24 and 26.)

The connection you choose depends on the cable type you have in your home, as described below.

### 75-ohm coaxial cable (usually found in newer homes)

#### Cable Type

#### Connect As Shown

VHF Only or  
combined  
VHF/UHF

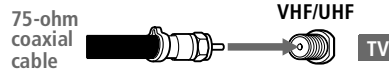

Cable

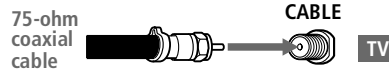

### 300-ohm twin lead cable (usually found in older homes)

#### Cable Type

#### Connect As Shown

VHF Only or  
UHF Only or  
combined  
VHF/UHF

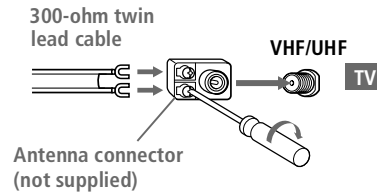

### 75-ohm coaxial and 300-ohm twin lead cable (found in some homes)

#### Cable Type

#### Connect As Shown

VHF and UHF

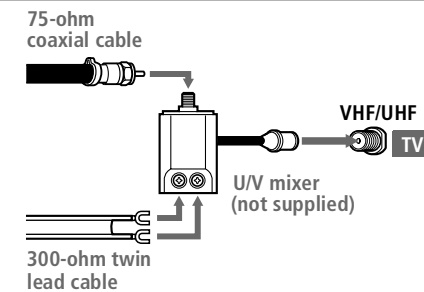

## Cable and Antenna Only

For best results, use this connection if you:

- ❑ Have a cable and an antenna.  
(This is convenient if you are using a separate rooftop antenna to receive additional channels, such as HDTV channels, that are not provided by your cable company.)
- ❑ Do not have a cable box or VCR. (if you have a cable box, see pages 21 to 22. If you have a VCR, see pages 24 and 26.)

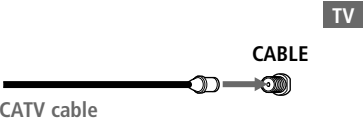
Cable Type	Connect As Shown
Cable TV (CATV) and Antenna	 <p>Antenna cable</p> <p>VHF/UHF</p>
	 <p>CABLE</p> <p>CATV cable</p>

### Notes on Using This Connection

To Do This ...	Do This ...
Switch the TV's input between the cable and antenna	Press ANT to switch back and forth between the TV's VHF/UHF and CABLE inputs.



## Cable Box and Cable Only

For best results, use this connection if:

- ❑ Your cable company scrambles some channels, such as premium channels (which requires you to use a cable box), but does not scramble all channels.
- ❑ You do not have a VCR. (If you have a VCR, see pages 24 and 26.)

With this connection you can:

- ❑ Use the TV remote control to change channels coming through the cable box to the TV's VHF/UHF input jack. (You must first program the remote control for your specific cable box; see "Programming the Remote Control" on page 49.)
- ❑ Use the TV remote control to change channels coming directly into the TV's CABLE input. (The TV's tuner provides a better signal than the cable box.)

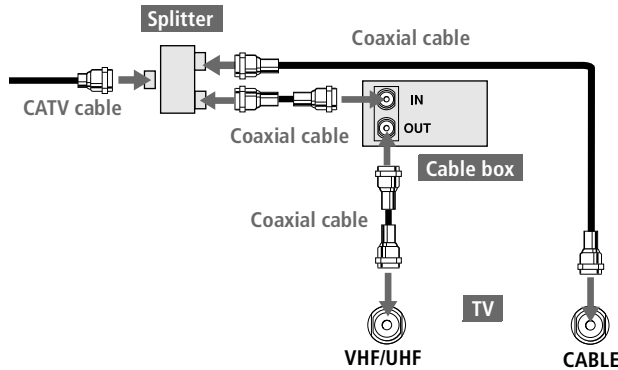

### About Using This Connection with Dual Picture (Twin View, etc.) Features

With this connection, you can use all the dual picture features for unscrambled channels coming directly into the TV's CABLE input jack.

### Notes on Using This Connection

To Do This ...	Do This ...
Use the cable box	Tune the TV to the channel the cable box is set to (usually channel 3 or 4) and then use the cable box to switch channels.
Set up the TV remote control to operate the cable box	Program the remote control. See "Programming the Remote Control" on pages 49-50.
Activate the remote control to operate the cable box	Press SAT/CABLE FUNCTION.
Prevent the accidental switching of TV channels	When using the cable box, you need the TV to stay on the channel the cable box is set to (usually channel 3 or 4). You can use the TV's Channel Fix feature to lock in a specific channel. For details, see "Using the Channel Menu" on page 98.
Switch the TV's input between the cable box and cable	Press ANT to switch back and forth between the TV's VHF/UHF (scrambled channels) and CABLE (unscrambled) inputs.

## Cable Box Only

For best results, use this connection if:

- ❑ Your cable company scrambles all channels, which requires you to use a cable box.
- ❑ You do not have a VCR. (If you have a VCR, see pages 24 and 26.)

With this connection you can:

- ❑ Use the TV remote control to change channels coming through the cable box to the TV's VHF/UHF jack. (You must first program the remote control for your specific cable box.)

### About Using This Connection with Dual Picture (Twin View, etc.) Features

With this connection, all channels come into the TV through your cable box and only one unscrambled signal is sent to the TV, so you cannot use the dual picture features. If some of your channels are scrambled, but others are not, consider using the "Cable Box and Cable" connection on page 21 instead.

To connect the cable box

- 1 Connect the CATV cable to the cable box's input jack.
- 2 Use a coaxial cable to connect the cable box's output jack to the TV's VHF/UHF jack.
- 3 Run the Auto Setup program, as described in "Setting Up the Channel List" on page 41.

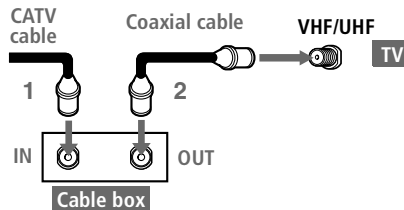

### Notes on Using This Connection

To Do This ...	Do This ...
Use the cable box	Tune the TV to the channel the cable box is set to (usually channel 3 or 4) and then use the cable box to switch channels.
Set up the TV remote control to operate the cable box	Program the remote control. See "Programming the Remote Control" on pages 49-50.
Activate the remote control to operate the cable box	Press SAT/CABLE FUNCTION.
Prevent the accidental switching of TV channels	When using the cable box, you need the TV to stay on the channel the cable box is set to (usually channel 3 or 4). You can use the TV's Channel Fix feature to lock in a specific channel. For details, see "Using the Channel Menu" on page 98.

# Connecting Optional Equipment

Use the directions in this section to connect the following optional equipment:

<i>If You Are Connecting</i>	<i>See Page</i>
VCR and Cable	24
VCR and Cable Box	26
Two VCRs for Tape Editing	28
Satellite Receiver	30
Satellite Receiver and VCR	32
DVD Player with Component Video Connectors	34
DVD Player with S VIDEO and Audio Connectors	36
Camcorder	37
Audio Receiver	38
Connecting a Device with an Optical IN Connector	39
Using the CONTROL S Feature	40

 **If you want to connect an i.LINK device, see “Connecting i.LINK Devices” on page 84.**

## About Using S VIDEO



If the optional equipment you are connecting has an S VIDEO jack (shown at left), you can use an S VIDEO cable for improved picture quality (compared to an A/V cable). Because S VIDEO carries only the video signal, you also need to connect audio cables for sound, as shown below.

Example of an S VIDEO Connection

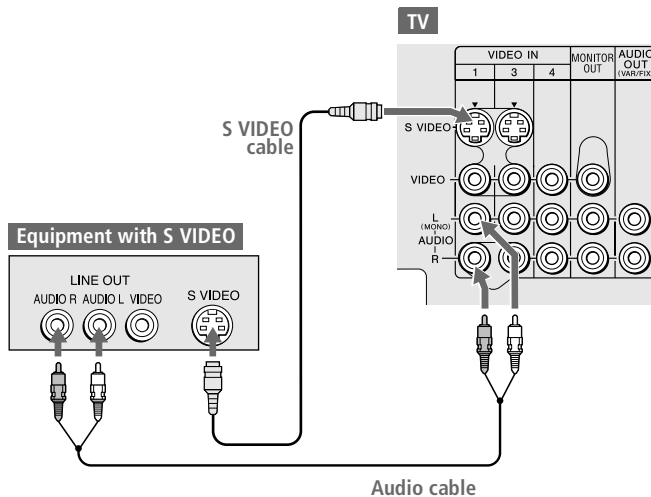

Cables are often color-coded to connectors. Connect red to red, white to white, etc.

## VCR and Cable

For best results, use this connection if:

- ❑ Your cable company does not require you to use a cable box.

### About Using This Connection with Dual Picture (Twin View, etc.) Features

With this connection, you can use all the dual picture features.

To connect the VCR and cable

- 1 Connect the CATV cable to the VCR's VHF/UHF input jack.
- 2 Use a coaxial cable to connect the VCR's VHF/UHF output jack to the TV's CABLE jack.
- 3 Use an A/V cable to connect the VCR's A/V output jacks to the TV's A/V input jacks.
- 4 Run the Auto Setup program, as described in "Setting Up the Channel List" on page 41.



Using  
S VIDEO jacks?  
See page 23.

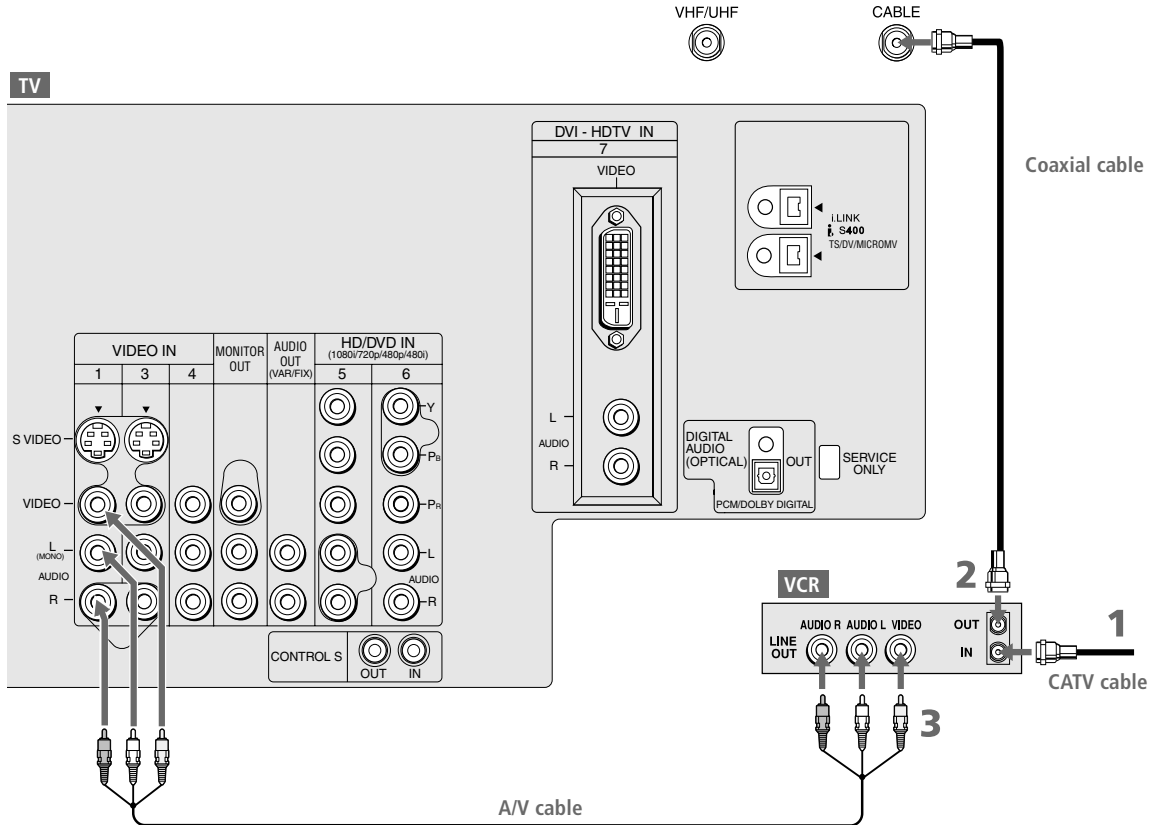

Cables are often color-coded to connectors. Connect red to red, white to white, etc.

## Notes on Using This Connection

<i>To Do This ...</i>	<i>Do This ...</i>
Watch the VCR	Press TV/VIDEO repeatedly to select the VCR input (VIDEO 1 in the illustration).
Watch cable channels	Press TV/VIDEO repeatedly to select the cable input (CABLE in the illustration).
Set up the TV remote control to operate the VCR	If you have a non-Sony VCR, you must program the remote control. See "Programming the Remote Control" on pages 49-50.
Activate the TV remote control to operate the VCR	Open the outside cover, as shown on page 48. Then set the A/V slide switch to the position you programmed for the VCR.
Control VCR functions with the TV remote control	See "Operating a VCR" on page 51.
Label video inputs to easily identify equipment connected to the TV	See the instructions for setting up Video Labels on pages 103-104.

## VCR and Cable Box

For best results, use this connection if:

- ❑ Your cable company scrambles some channels, such as premium channels (which requires you to use a cable box), but does not scramble all channels.

### About Using This Connection with Dual Picture (Twin View, etc.) Features

With this connection, you can use all the dual picture features.

With this connection you can:

- ❑ Use the TV remote control to change channels coming through the cable box. (You must first program the remote control for your specific cable box; see “Programming the Remote Control” on page 49.)
- ❑ Use the TV remote control to change channels coming directly into the TV’s CABLE jack. (The TV’s tuner provides a better signal than the cable box.)
- ❑ Record channels coming through the cable box and channels coming directly into the TV.

To connect a VCR and cable box, you need:

- ❑ A splitter, which is a small, inexpensive device that you can purchase at your local electronics store.
- ❑ Three coaxial cables.
- ❑ One A/V cable or one S VIDEO cable with audio cables.

To connect the VCR and cable box

- 1 Connect the CATV cable to the single (input) jack of the splitter.
- 2 Use a coaxial cable to connect one of the splitter’s two output jacks to the TV’s CABLE jack.
- 3 Use a coaxial cable to connect the splitter’s other output jack to the cable box’s input jack.
- 4 Use a coaxial cable to connect the cable box’s output jack to the VCR’s RF input jack.
- 5 Use an A/V cable to connect the VCR’s A/V output jacks to the TV’s A/V input jacks.
- 6 Use a coaxial cable to connect the VCR’s RF output jack to the TV’s VHF/UHF jack.
- 7 Run the Auto Setup program, as described in “Setting Up the Channel List” on page 41.



Using  
S VIDEO jacks?  
See page 23.

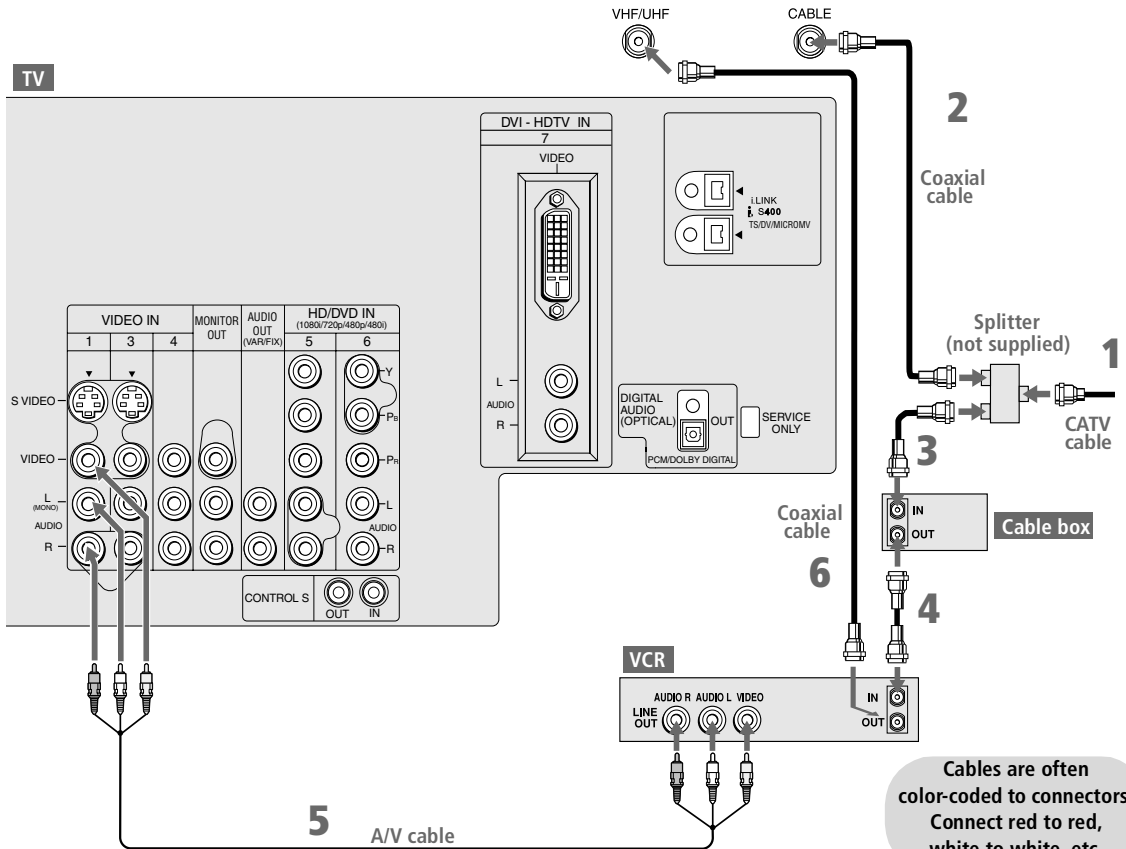

## Notes on Using This Connection

To Do This ...	Do This ...
Watch cable (unscrambled) channels	Press TV/VIDEO repeatedly to select the cable input (CABLE in the illustration).
Watch cable box (scrambled) channels	Turn on the VCR and tune it to the channel the cable box is set to (usually channel 3 or 4). Press TV/VIDEO repeatedly to select the VCR input (VIDEO 1 in the illustration). Use the cable box to change channels.
Watch the VCR	Press TV/VIDEO repeatedly to select the VCR input (VIDEO 1 in the illustration).
Set up the TV remote control to operate the cable box or VCR	If you have a non-Sony VCR, you must program the remote control. See "Programming the Remote Control" on pages 49-50.
Activate the remote control to operate the cable box or VCR	For the cable box, press SAT/CABLE FUNCTION. For the VCR, open the outside cover, as shown on page 48. Then set the A/V slide switch to the position you programmed for the VCR.
Control specific cable box and VCR functions with the TV remote control	See "Operating a Cable Box" on page 52 and "Operating a VCR" on page 51.
Label video inputs to easily identify equipment connected to the TV	See the instructions for setting up Video Labels on pages 103-104.

## Two VCRs for Tape Editing



Using  
S VIDEO jacks?  
See page 23.

Connecting two VCRs lets you record from one VCR to the other. By connecting them as shown below, you can view (monitor) what is being recorded.

To connect two VCRs for tape editing

- 1 Use an A/V cable to connect the playback VCR's A/V output jacks to the TV's A/V input jacks.
- 2 Use an A/V cable to connect the recording VCR's A/V input jacks to the TV's MONITOR OUT jacks.

VHF/UHF



CABLE



TV

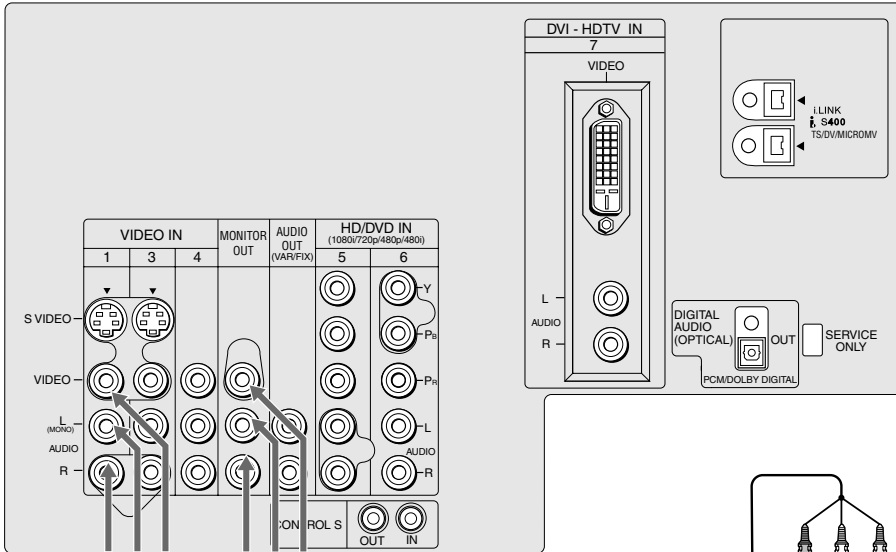

A/V cable

2

Recording VCR

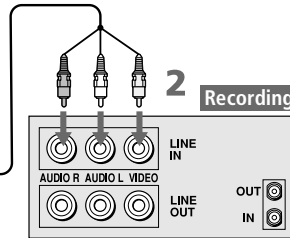

Playback VCR

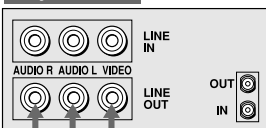

1

A/V cable

Cables are often  
color-coded to connectors.  
Connect red to red,  
white to white, etc.



## Notes on Using This Connection

<i>To Do This ...</i>	<i>Do This ...</i>
View (monitor) what is being recorded	Press TV/VIDEO repeatedly to select the VCR input (VIDEO 1 in the illustration above).
Set up the TV remote control to operate the VCR(s)	If you have a non-Sony VCR, you must program the remote control. See "Programming the Remote Control" on pages 49-50.
Activate the TV remote control to operate the VCR(s)	Open the outside cover, as shown on page 48. Then set the A/V slide switch to the position you programmed for the VCR.
Control VCR functions with the TV remote control	See "Operating a VCR" on page 51.
Label video inputs to easily identify equipment connected to the TV	See the instructions for setting up Video Labels on pages 103-104.

## Satellite Receiver



Using  
S VIDEO jacks?  
See page 23.

To connect a satellite receiver

- 1 Connect the satellite antenna cable to the satellite receiver's satellite input jack.
- 2 Use an A/V cable to connect the satellite receiver's A/V output jacks to the TV's A/V input jacks.
- 3 Connect a cable from your cable or antenna to the TV's CABLE or VHF/UHF jack.
- 4 Run the Auto Setup program, as described in "Setting Up the Channel List" on page 41.

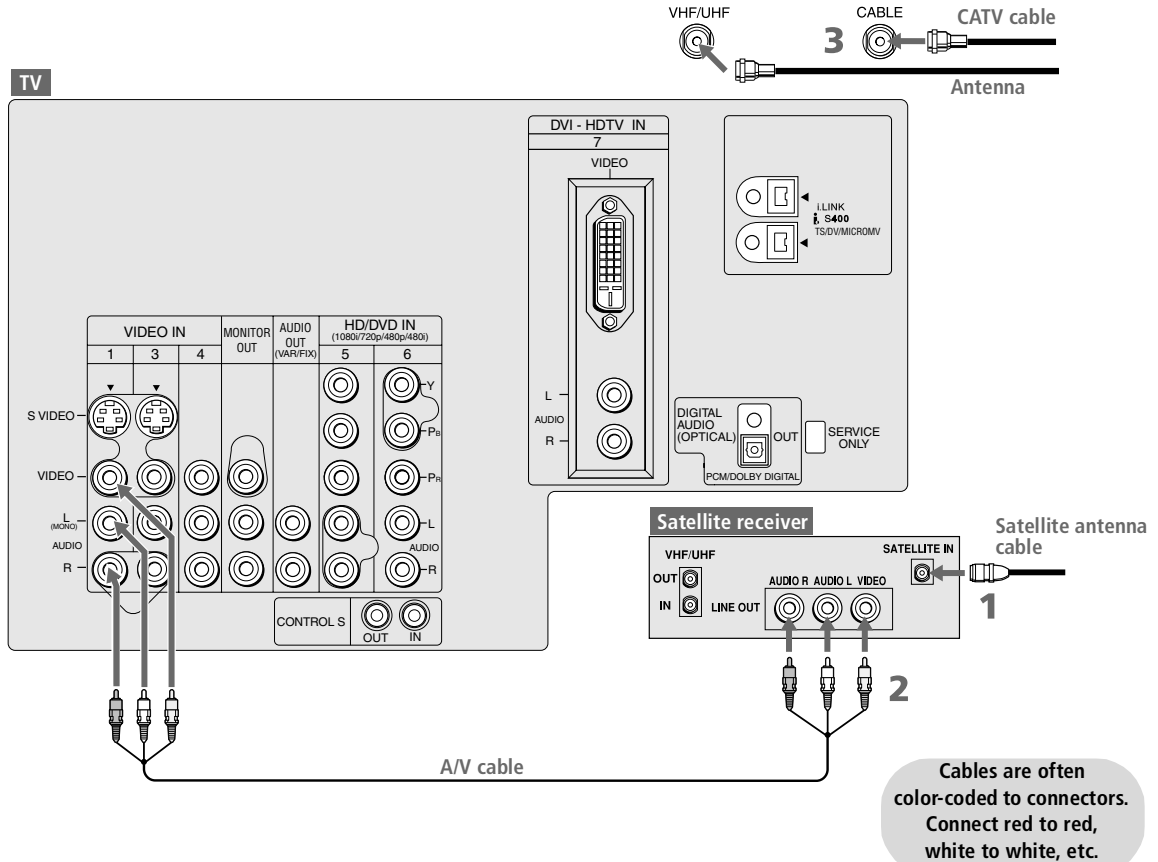

## Notes on Using This Connection

<i>To Do This ...</i>	<i>Do This ...</i>
Watch the satellite receiver	Press TV/VIDEO repeatedly to select the satellite receiver input (VIDEO 1 in the illustration).
Set up the TV remote control to operate the satellite receiver	If you have a non-Sony satellite receiver, you must program the remote control. See "Programming the Remote Control" on pages 49-50.
Activate the TV remote control to operate the satellite receiver	Press SAT/CABLE FUNCTION.
Control satellite receiver functions with the TV remote control	See "Operating a Satellite Receiver" on page 51.
Label video inputs to easily identify equipment connected to the TV	See the instructions for setting up Video Labels on pages 103-104.

## Satellite Receiver and VCR



Using  
S VIDEO jacks?  
See page 23.

### To connect a satellite receiver and VCR

- 1 Connect the satellite antenna cable to the satellite receiver's satellite input jack.
- 2 Connect the CATV cable to the VCR's VHF/UHF input jack.
- 3 Use a coaxial cable to connect the VCR's VHF/UHF output jack to the TV's CABLE jack.
- 4 Use an A/V cable to connect the satellite receiver's A/V output jacks to the VCR's A/V input jacks.
- 5 Use an A/V cable to connect the VCR's A/V output jacks to the TV's A/V input jacks.
- 6 Run the Auto Setup program, as described in "Setting Up the Channel List" on page 41.

### Notes on Using This Connection

<i>To Do This ...</i>	<i>Do This ...</i>
Watch the satellite receiver	Press TV/VIDEO repeatedly to select the VCR input (VIDEO 1 in the illustration).  The VCR may need to be turned on and set to the satellite receiver input.
Watch the VCR	Press TV/VIDEO repeatedly to select the input to which the VCR is connected (VIDEO 1 in the illustration).
Set up the TV remote control to operate the satellite receiver or VCR	If you have a non-Sony VCR or satellite receiver, you must program the remote control. See "Programming the Remote Control" on pages 49-50.
Activate the TV remote control to operate the satellite receiver or VCR	For the satellite receiver, press SAT/CABLE FUNCTION. For the VCR, open the outside cover, as shown on page 48. Then set the A/V slide switch to the position you programmed for the VCR.
Control satellite receiver and VCR functions with the TV remote control	See "Operating a Satellite Receiver" on page 51 and "Operating a VCR" on page 51.
Label video inputs to easily identify equipment connected to the TV	See the instructions for setting up Video Labels on pages 103-104.

TV

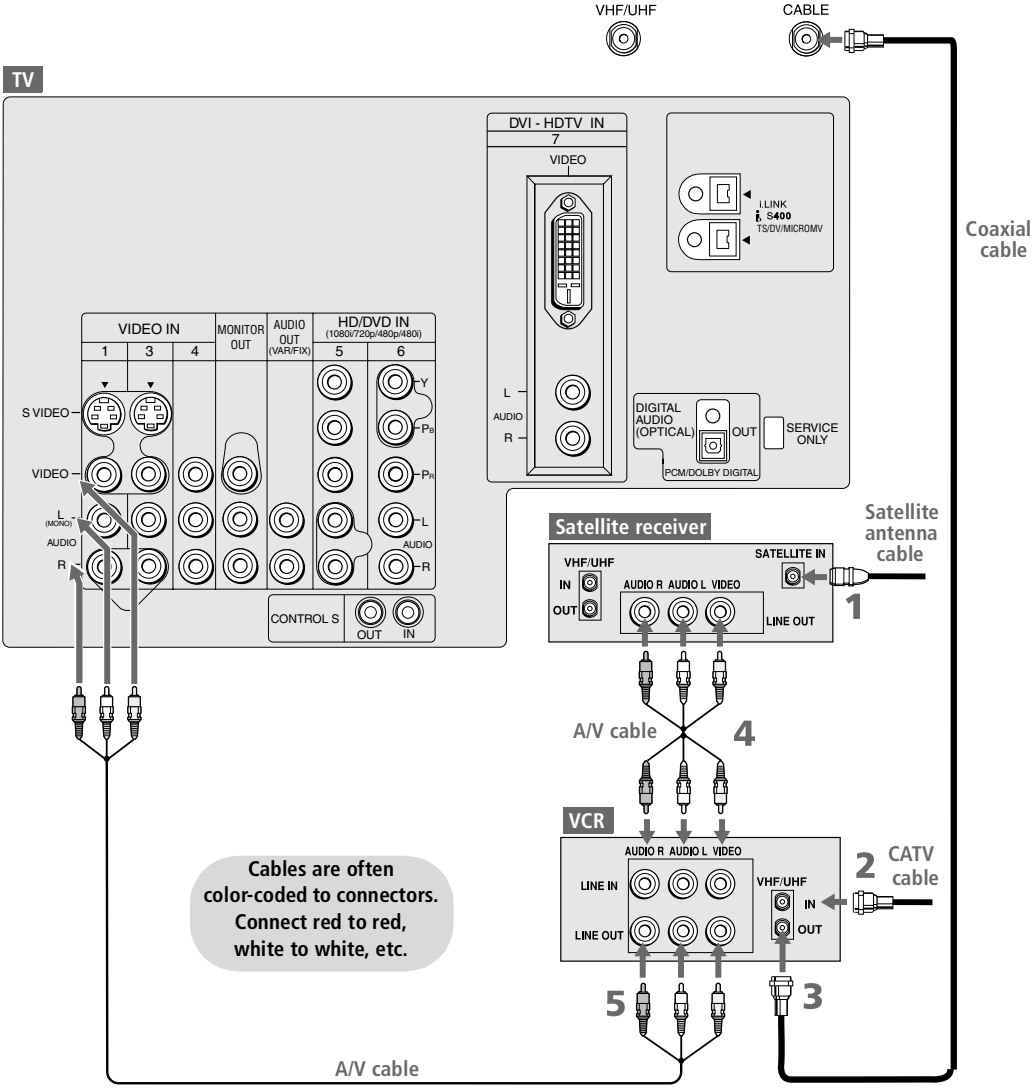

## DVD Player with Component Video Connectors

For best results, use this connection if your DVD player has component video (Y, P<sub>B</sub>, P<sub>R</sub>) jacks.

To connect a DVD player with component video connectors

- 1 Use a component video cable, or three composite video cables, to connect the DVD player's Y, P<sub>B</sub> and P<sub>R</sub> jacks to the Y, P<sub>B</sub> and P<sub>R</sub> jacks (VIDEO 5) on the TV.

 The Y, P<sub>B</sub> and P<sub>R</sub> jacks on your DVD player are sometimes labeled Y, C<sub>B</sub> and C<sub>R</sub>, or Y, B-Y and R-Y. If so, connect the cables to like colors.

- 2 Use an audio cable to connect the DVD player's audio output jacks to the TV's VIDEO 5 audio input jacks.

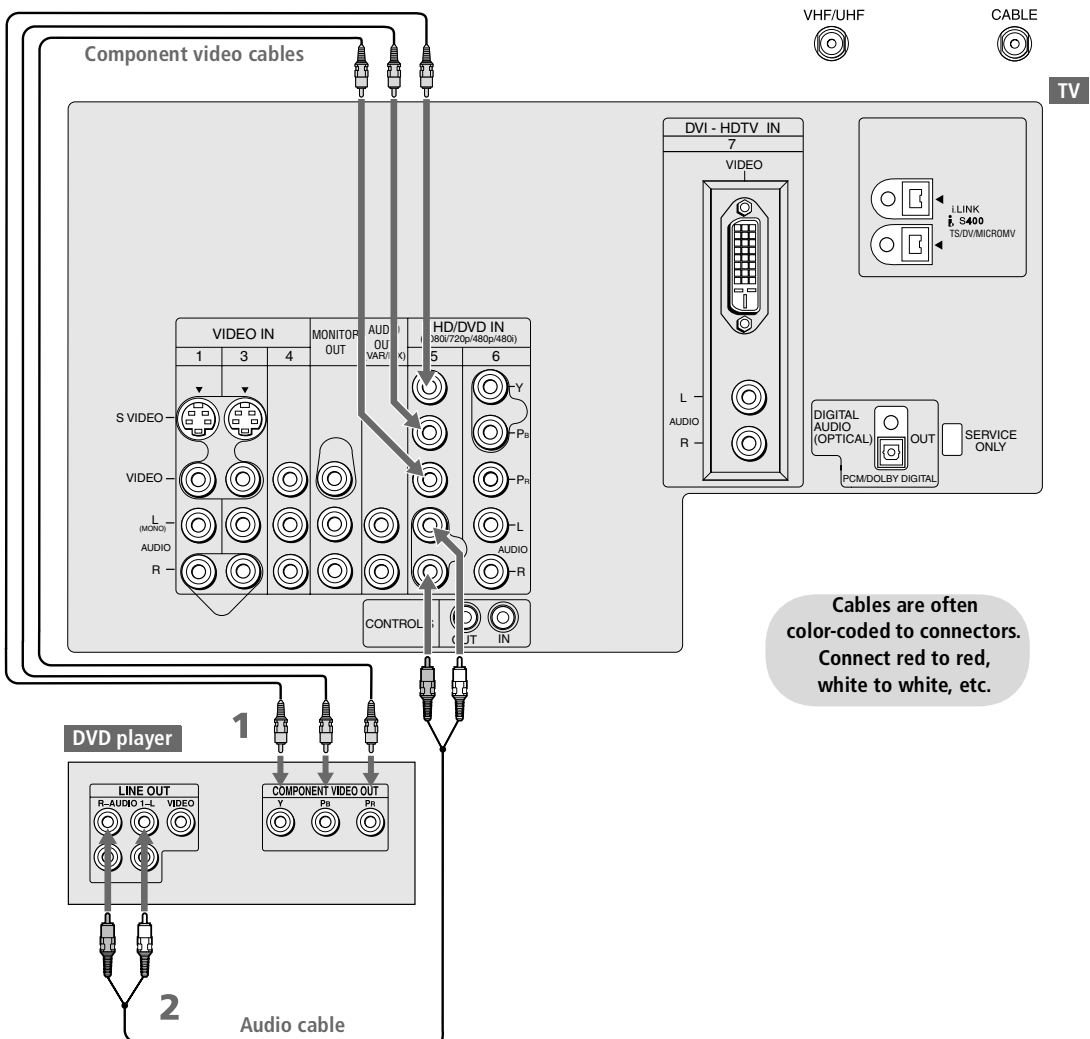

## Notes on Using This Connection

<i>To Do This ...</i>	<i>Do This ...</i>
Watch the DVD player	Press TV/VIDEO repeatedly to select the DVD input (VIDEO 5 in the illustration).
Set up the TV remote control to operate the DVD player	If you have a non-Sony DVD player, you must program the remote control. See "Programming the Remote Control" on pages 49-50.
Activate the TV remote control to operate the DVD player	Open the outside cover, as shown on page 48. Then set the A/V slide switch to the position you programmed for the DVD player.
Control DVD functions with the TV remote control	See "Operating a DVD Player" on page 52.
Label video inputs to easily identify equipment connected to the TV	See the instructions for setting up Video Labels on pages 103-104.

 **You cannot record the signal from any equipment connected into the Y, PB, PR jacks.**

## DVD Player with S VIDEO and Audio Connectors

Use this connection if your DVD player does not have component video (Y, PB, PR) jacks.

To connect a DVD player with A/V connectors

- 1 Use an audio cable to connect the DVD player's audio output jacks to the TV's audio input jacks.
- 2 Use an S VIDEO cable to connect the DVD player's S VIDEO jack to the TV's S VIDEO jack.

Cables are often color-coded to connectors. Connect red to red, white to white, etc.

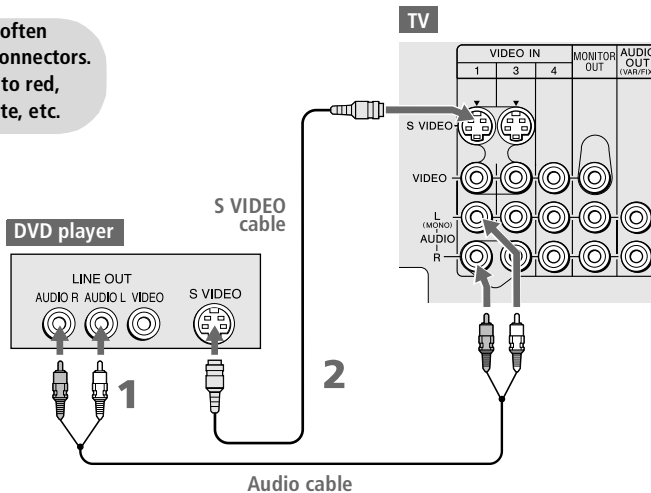

### Notes on Using This Connection

To Do This ...	Do This ...
Watch the DVD player	Press TV/VIDEO repeatedly to select the DVD input (VIDEO 1 in the illustration).
Set up the TV remote control to operate the DVD player	If you have a non-Sony DVD player, you must program the remote control. See "Programming the Remote Control" on pages 49-50.
Activate the TV remote control to operate the DVD player	Open the outside cover, as shown on page 48. Then set the A/V slide switch to the position you programmed for the DVD player.
Control DVD functions with the TV remote control	See "Operating a DVD Player" on page 52.
Label video inputs to easily identify equipment connected to the TV	See the instructions for setting up Video Labels on pages 103-104.



## Camcorder



Using  
S VIDEO jacks?  
See page 23.

For easy connection of a camcorder, the TV has front A/V input jacks. If you prefer, however, you can connect the camcorder to the TV's rear A/V input jacks.

 **If your camcorder is equipped with an i.LINK jack, see "Using i.LINK" on page 83.**

To connect a camcorder

- 1 Open the front video panel, as shown on page 13.
- 2 Use A/V cables to connect the camcorder's A/V output jacks to the TV's A/V input jacks.

TV Front Video Panel

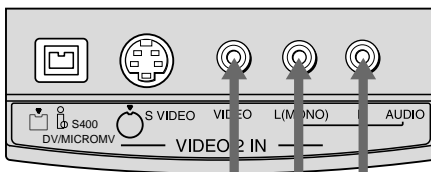

Cables are often  
color-coded to connectors.  
Connect red to red,  
white to white, etc.

A/V cable

To A/V output

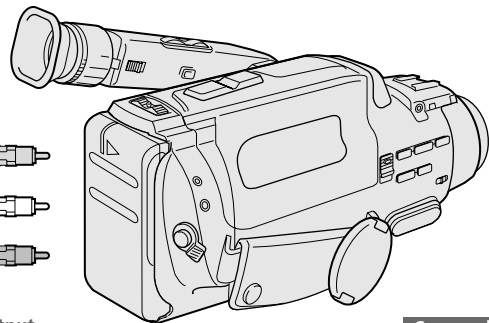

Camcorder

If you have a mono camcorder, connect its audio output jack to the TV's L MONO audio jack.

### Notes on Using This Connection

**To Do This ...**

Watch the camcorder

Label video inputs to easily  
identify equipment connected  
to the TV

**Do This ...**

Press TV/VIDEO repeatedly to select the camcorder input (VIDEO 2 in the illustration).

See the instructions for setting up Video Labels on pages 103-104.

## Audio Receiver

For improved sound quality, you may want to play the TV's audio through your stereo system.

To connect an audio system

- 1 Use an audio cable to connect the TV's audio output jacks to the audio receiver's line input jacks.

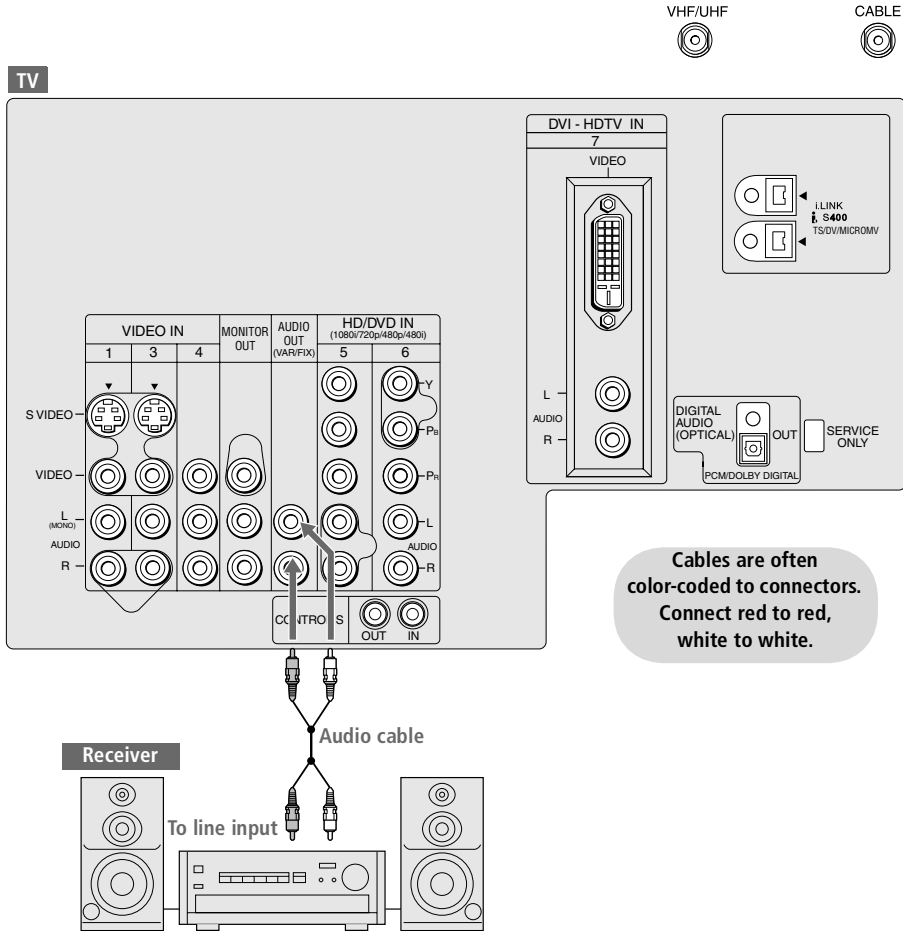



- 2 Using the TV's Audio Menu, set the Speaker option to Off. Then set the Audio Out option to Fixed or Variable, depending on how you want to control the volume. For details, see "Using the Audio Menu" on page 94.
- 3 Turn on the audio receiver, and then set the receiver's line input to the jack into which you connected the TV.

## Connecting a Device with an Optical IN Connector

You can use the TV's DIGITAL AUDIO OPTICAL output jack to connect an audio device that is Dolby Digital and PCM compatible, such as an audio amplifier.

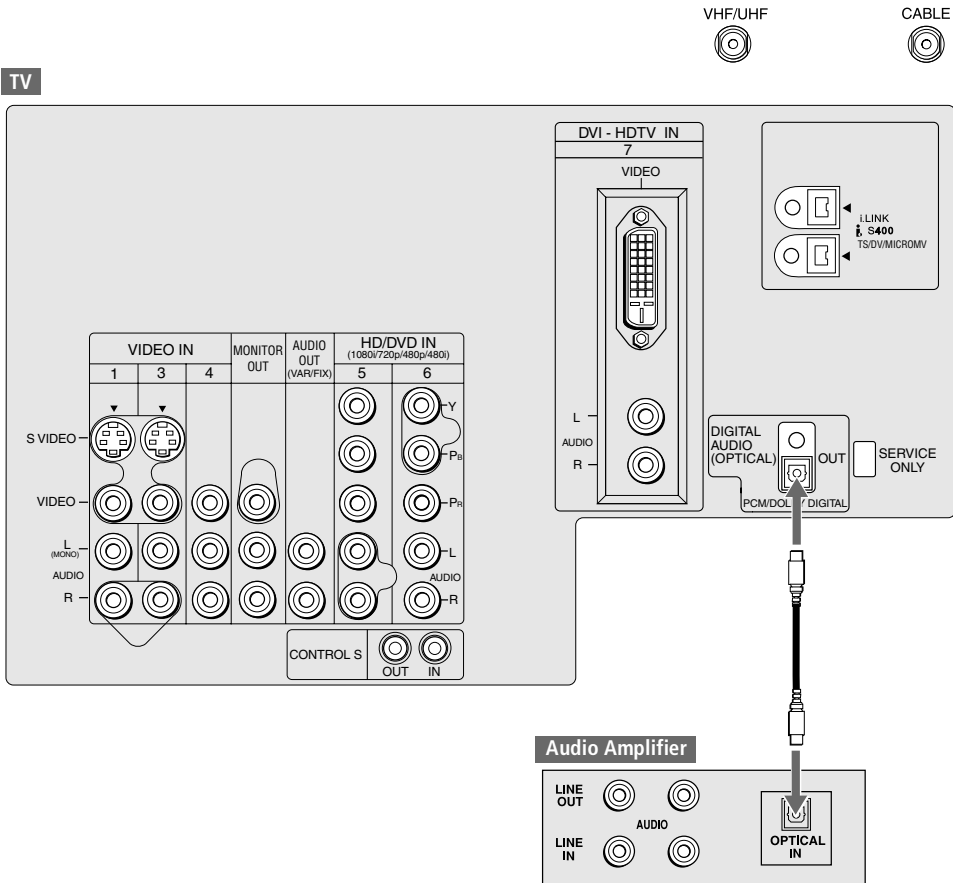
- Using an optical cable, connect the TV's DIGITAL AUDIO OPTICAL output jack to the device's audio optical input jack.



 Because all equipment does not output digital audio, you should also connect the TV's analog audio output jacks to the amplifier's analog audio input jacks, as described on page 38.

# Using the CONTROL S Feature

CONTROL S allows you to control your system and other Sony equipment with one remote control. In addition to allowing you to control multiple devices with one remote control, the CONTROL S feature allows you to always point your remote control at your TV, instead of having to point it at the other equipment, which might be hidden or out of direct line of sight.

Use CONTROL S IN to send signals to the TV.

Use CONTROL S OUT to send signals to connected equipment.

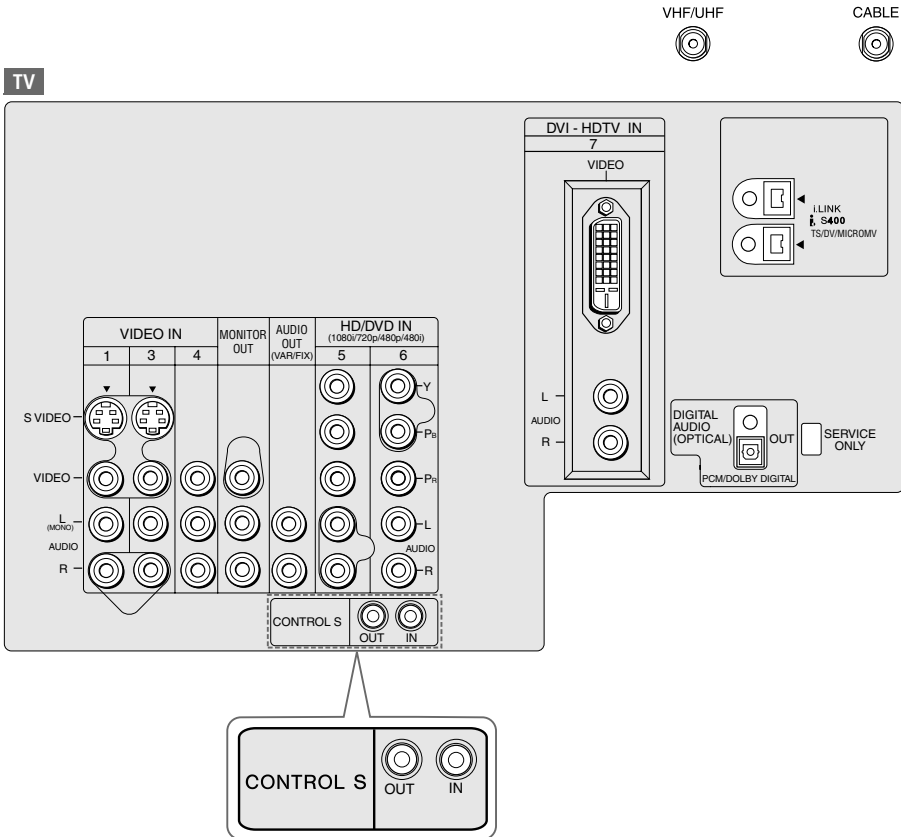

## Setting Up the Channel List

After you finish connecting the TV, you need to run the Auto Program feature, which automatically creates a list of available analog and digital channels. The Auto Program screens appear when you turn on your TV for the first time after hooking it up.

---

### Using Auto Program

To run Auto Program the first time you turn on your TV

- 1 Press POWER to turn on the TV.  
The Initial Setup screen appears.
- 2 Using the joystick on the remote control, move the highlight to the desired language, then press  $\oplus$  to select that language.
- 3 When prompted to start Auto Program, press  $\oplus$  to select Yes.

Auto Program takes several minutes to complete. A progress bar is displayed while the channel list is being created.

To run Auto Program again at a later time

- Use the Auto Program feature as described on page 98.

To add individual digital channels

- Use the Digital Channel feature as described on page 98.

To reset the TV to factory settings

- 1 Press POWER to turn on the TV.
- 2 Hold down RESET on the remote control.
- 3 Press TV POWER on the TV. (The TV will turn itself off, then back on.)
- 4 Release RESET.

## Adjusting the Convergence Automatically (Flash Focus)

The projection tube image appears on the screen in three colors (red, green and blue). If they do not converge, the color is poor and the picture blurs. Before you use your TV, be sure to adjust the convergence. The Flash Focus feature allows you to adjust the convergence automatically.

 **It is recommended that you perform Flash Focus about 30 minutes after the TV is first turned on.**

 You can also access Flash Focus in the Setup menu. For details, see page 103.

- 1 Tune to a TV or cable TV program.
- 2 Press the FLASH FOCUS button on the front panel of the TV (see page 15).

The cross pattern appears and Flash Focus begins to work.

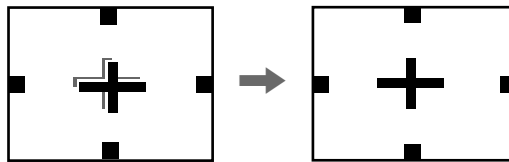

The adjustment is completed when the TV picture returns.

**To Perform Additional Fine Manual Adjustments**

Use the Manual Convergence feature, described on page 43.

### Notes on Flash Focus

- You cannot perform any other functions until Flash Focus has completed its cycle. If you perform any other operation while Flash Focus is in progress, the Flash Focus operation is canceled.
- Flash Focus will not set the TV's convergence to the factory setting. To do this, press RESET while in Manual Convergence mode.

## Adjusting the Convergence Manually

The Convergence feature gives you more control over the picture's convergence than the Flash Focus feature, allowing you to fine-tune the convergence.

 **Before adjusting the convergence manually for the first time, you must first perform Flash Focus (as described on page 42).**

 For details on using the Setup Menu, see page 103.

- 1 Press MENU to display the Menu.
- 2 Move the joystick  $\leftarrow$  or  $\rightarrow$  to highlight the Setup icon and press  $\odot$ .
- 3 Move the joystick to highlight Convergence and press  $\odot$ .

A pattern of white crosses appears, with a yellow [ ] around one of the crosses. Aligned crosses (which do not need adjustment) look white and have little or no red or blue showing. Crosses that are not aligned show red or blue shades beyond their edges.

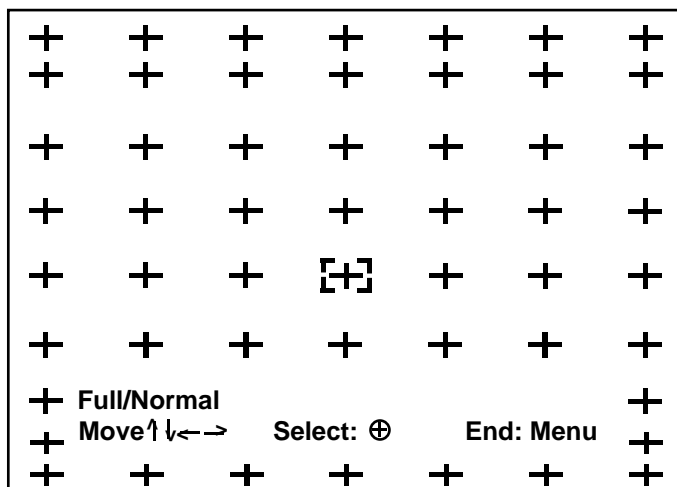

You can scroll up and down through the 9 x 7 field of crosses to manually converge all portions of the screen.

- 4 Using the joystick, move the [ ] to surround a cross that you want to adjust. Press  $\odot$ . The [ ] changes to red.
- 5 If the cross that you selected has red edges, move the joystick until the red image is replaced with a white cross. Once you have finished this (or the cross does not have red edges), press  $\odot$ . The [ ] changes to blue.
- 6 If the cross you selected has blue edges, move the joystick until the blue image is replaced with a white cross. Once you have finished this, press  $\odot$ . The [ ] changes to yellow again.
- 7 Repeat steps 4 to 6 to adjust other crosses. When finished, press MENU to exit the Setup Menu.

---

## **Notes on Adjusting the Convergence Manually**

- ❑ Allow the TV to warm up for about 30 minutes before you adjust the convergence.
- ❑ For best results, stand about 3 to 5 feet back from the picture when adjusting the convergence. Begin with the crosses in the center area of the screen and, once those are adjusted, move to the crosses on the edges of the screen.
- ❑ You can make separate adjustments to each wide mode: Full/Normal, Zoom, Wide Zoom, and Memory Stick/1080i high-definition input. (These features share a common convergence mode.) The cross pattern looks different in each of these, but the adjustment procedure is the same. Press the **WIDE MODE** button on the remote to toggle through the wide mode screens.
- ❑ To optimize the conditions for convergence adjustment, in the Video Menu, set *Mode* to *Pro* or *Movie* and lower the *Picture* level settings (see page 92). You can reset the adjustments by pressing the **RESET** button on the remote control.



# Using the Remote Control

## Overview

This chapter describes how to set up, program, and use the TV's remote control.

Topic	Page
Inserting Batteries	45
Button Descriptions	
Outside Panel	46
Inside Panel	48
Programming the Remote Control	49

## Inserting Batteries

- 1 Remove the battery cover from the remote control.
- 2 Insert two size AA (R6) batteries (supplied) by matching the **+** and **-** terminals on the batteries to the diagram inside the battery compartment.
- 3 Replace the battery cover.

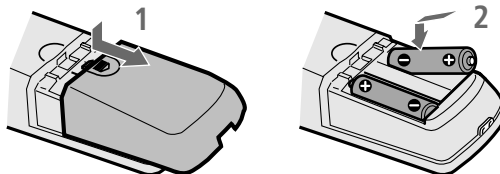

 Remove the batteries to avoid damage from possible battery leakage whenever you anticipate that the remote control will not be used for an extended period.

Handle the remote control with care.

Avoid dropping it, getting it wet, placing it in direct sunlight, near a heater, or where the humidity is high.

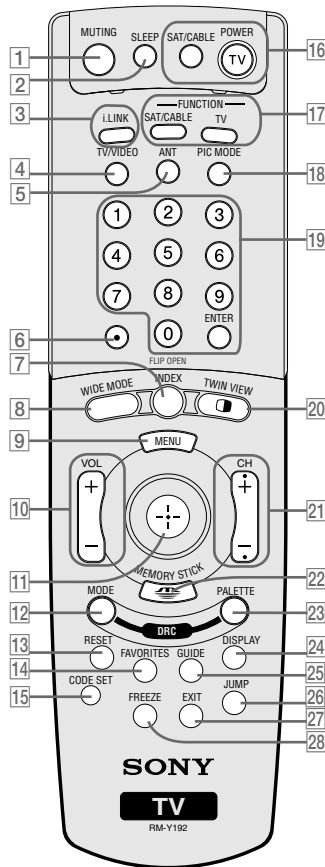

# Button Descriptions

## Outside Panel



Remote Control

Button	Description
1 MUTE	Press to mute the sound. Press again or press VOL+ to restore the sound.
2 SLEEP	Press repeatedly until the TV displays the time in minutes (15, 30, 45, 60, or 90) that you want the TV to remain on before shutting off automatically. To cancel press until Sleep Off appears. While the Sleep feature is set, press once to display the remaining time.
3 i.LINK	Press to display the i.LINK Control Panel. For information on using the i.LINK Control Panel, see page 87.
4 TV/VIDEO	Press repeatedly to cycle through the video equipment connected to the TV's video inputs.
5 ANT	Press to switch between the sources connected to the TV's VHF/UHF and CABLE inputs.
6	Use with 0-9 and ENTER buttons to select digital channels (for example, 2.1). For details on selecting digital channels, see pages 54 and 58.
7 INDEX	Press to display the Scrolling Index. For details, see page 55.
8 WIDE MODE	Press repeatedly to step through the Wide Mode settings: Wide Zoom, Normal, Full, Zoom. Also available in the Screen menu. For details, see pages 56 and 96.
9 MENU	Press to display the Menu. Press again to exit from the Menu. For details, see page 91.
10 VOL +/-	Press to adjust the volume.
11	Move the joystick $\uparrow$ $\downarrow$ $\leftarrow$ $\rightarrow$ to move the on-screen cursor. To select an item, press the center of the joystick ( $\oplus$ ).
12 DRC MODE	Press repeatedly to cycle through the available high-resolution picture modes: Interlaced, Progressive, CineMotion. Also available in the Video Menu. For details, see "Selecting Video Options" on pages 92-93.
13 RESET	Press to reset the settings to the factory defaults. See pages 92 and 94. Also used to clear Favorite Channels, (see page 60), and Manual Convergence (see page 44).
14 FAVORITES	Press to display the Favorite Channels list. For details, see page 60.
15 CODE SET	Press to program the remote control to operate non-Sony video equipment. For details, see "Programming the Remote Control" on page 49.

<b>Button</b>	<b>Description</b>
16 POWER Buttons	SAT/CABLE: Press to turn on and off the satellite receiver or cable box. TV: Press to turn on and off the TV.
17 FUNCTION Buttons	The indicator lights up momentarily when pressed to show which equipment the remote control is operating: SAT/CABLE: Press to have the remote control operate the satellite receiver or cable box. TV: Press to have the remote control operate the TV.
18 PIC MODE	Press repeatedly to cycle through the available video picture modes: Vivid, Standard, Movie, Pro. Also available in the Video Menu. For details, see "Selecting Video Options" on page 92.
19 0 - 9 ENTER	Press 0 - 9 to select a channel; the channel changes after 3 seconds. Press ENTER to change channels immediately.
20 TWIN VIEW 	Press to turn on and off Twin View. For details, see pages 57-59.
21 CH +/-	Press to scan through channels. To scan quickly through channels, press and hold down either CH button.
22 MEMORY STICK 	Press to display the Memory Stick Menu. For details, see "Using the Memory Stick Viewer" on page 67.
23 DRC PALETTE	Press repeatedly to cycle through the three Custom DRC Palette options. Also available in the Video Menu. For details, see "Selecting Video Options" on pages 92-93.
24 DISPLAY	Press once to display the current channel number, current time, and program information banner (if set). Press again to turn Display off.
25 GUIDE	Press to display the digital program guide. For details, see page 63.
26 JUMP	Press to jump back and forth between two channels. The TV alternates between the current channel and the last channel that was selected.
27 EXIT	Press to exit the on-screen menu or display and return to normal viewing.
28 FREEZE	Press to freeze the window picture. Press again to restore the picture. For details see page 61.

## Inside Panel

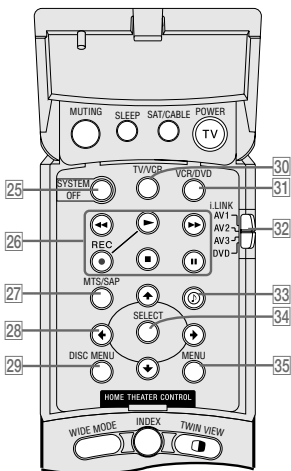
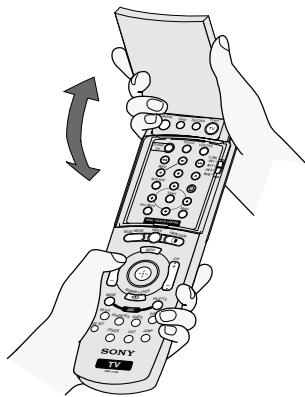

To access the inside panel, open the outside cover as shown.

**Opening the outside cover automatically switches the remote control to operate your VCR or DVD player, depending on the position of the A/V slide switch. For details, see page 49.**

**VCR and DVD buttons require that you first program the remote (page 49), if the VCR and DVD player are not Sony brand.**

Button	Description
25 SYSTEM OFF	Press to turn off all Sony brand audio/video equipment at once. (May not function with older Sony equipment.)
26 Transport Buttons	<ul style="list-style-type: none"> <li>◀◀ Rewind</li> <li>▶▶ Play</li> <li>● Record (press together with ▶)</li> <li> <b>To record with i.LINK devices, press only ●.</b></li> <li>■ Stop</li> <li>▶▶ Fast forward</li> <li>   Pause</li> </ul>
27 MTS/SAP	Press repeatedly to cycle through the Multi-channel TV Sound (MTS) options: Stereo, Auto SAP (Second Audio Program), and Mono. Also available in the Audio Menu. For details, see "Using the Audio Menu" on page 94.
28 ↑ ↓ ← →	Press ↑ ↓ ← → to move the VCR or DVD player's on-screen cursor.
29 DISC MENU	Press to display the DVD Menu.
30 TV/VCR	Press to change to the VHF/UHF output of the VCR.
31 VCR/DVD	Press to turn on and off the VCR or DVD player.
32 i.LINK AV1/2/3/DVD Slide Switch	Use the A/V slide switch to control connected video or i.LINK equipment. You can program one video source for each switch position. i.LINK-connected devices are by default set to AV1. For details, see "Programming the Remote Control" on page 49.
33	Press repeatedly to step through the Audio Effect options. Also available in the Audio Menu. For details, see page 94.
34 SELECT	Press to select an item in the VCR or DVD player's menu.
35 MENU	Press to display the DVD player setup menu.

# Programming the Remote Control

The remote control is preset to operate Sony brand video equipment.

Sony Equipment	Switch Position on Remote Control	Programmable Code Number
i.LINK	i.LINK/ AV1	901
8 mm VCR	AV2	302
VHS VCR	AV3	301
DVD player	DVD	751

If you have video equipment other than Sony brand that you want to control with the TV's remote control, use the following procedure to program the remote control.

 **The equipment must have infrared (IR) remote capability in order to be used with the remote control.**

- 1 Turn to the list of "Manufacturer's Codes" on page 50, and find the three-digit code number for the manufacturer of your equipment. (If more than one code number is listed, use the number listed first.)
- 2 Open the remote control and set the A/V slide switch to i.LINK/AV1, AV2, AV3, or DVD. Then close the remote control.

 **If the device that you wish to program is connected through i.LINK, you must set the slide switch to AV1.**

- 3 Press CODE SET.
- 4 Enter the three-digit manufacturer's code number.
- 5 Press ENTER.

 **You must do step 5 within 10 seconds of step 4, or you must redo steps 3 through 5.**

- 6 To check if the code number works, aim the TV's remote control at the equipment and press the POWER button that corresponds with that equipment. If it responds, you are done. If not, try using another code listed for that manufacturer.

### Notes

- If more than one code number is listed, try entering them one by one until you come to the correct code for your equipment.
- If you enter a new code number, the code number you previously entered at that setting is erased.
- In some cases, you may not be able to operate your equipment with the supplied remote control. In such cases, use the equipment's own remote control unit.
- Whenever you remove the batteries to replace them, the code numbers may revert to the factory setting and must be reset.

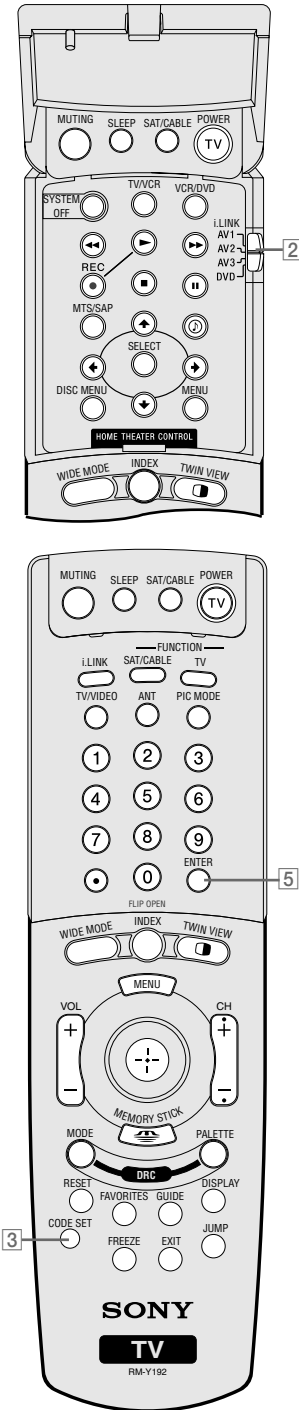

## Manufacturer's Codes

### VCRs

Manufacturer	Code
Sony	301, 302, 303
Admiral (M. Ward)	327
Aiwa	338, 344
Audio	314, 337
Dynamic	
Broksonic	319, 317
Canon	309, 308
Citizen	332
Craig	302, 332
Criterion	315
Curtis Mathes	304, 338, 309
Daewoo	341, 312, 309
DBX	314, 336, 337
Dimensia	304
Emerson	319, 320, 316, 317, 318, 341
Fisher	330, 335
Funai	338
General Electric	329, 304, 309
Go Video	322, 339, 340
Goldstar	332
Hitachi	306, 304, 305, 338
Instant Replay	309, 308
JC Penney	309, 305, 304, 330, 314, 336, 337
JVC	314, 336, 337, 345, 346, 347
Kenwood	314, 336, 332, 337
LXI (Sears)	332, 305, 330, 335, 338
Magnavox	308, 309, 310
Marantz	314, 336, 337
Marta	332
Memorex	309, 335
Minolta	305, 304
Mitsubishi/ MGA	323, 324, 325, 326
Multitech	325, 338, 321
NEC	314, 336, 337
Olympic	309, 308
Optimus	327

Manufacturer	Code
Orion	317
Panasonic	308, 309, 306, 307
Pentax	305, 304
Philco	308, 309
Philips	308, 309, 310
Pioneer	308
Quasar	308, 309, 306
RCA/ PROSCAN	304, 305, 308, 309, 311, 312, 313, 310, 329
Realistic	309, 330, 328, 335, 324, 338
Sansui	314
Samsung	322, 313, 321
Sanyo	330, 335
Scott	312, 313, 321, 335, 323, 324, 325, 326
Sharp	327, 328
Signature 2000 (M. Ward)	338, 327
SV2000	338
Sylvania	308, 309, 338, 310
Symphonic	338
Tashiro	332
Tatung	314, 336, 337
Teac	314, 336, 338, 337
Technics	309, 308
Toshiba	312, 311
Wards	327, 328, 335, 331, 332
Yamaha	314, 330, 336, 337
Zenith	331

### Laserdisc Players

Manufacturer	Code
Sony	701
Panasonic	704, 710
Pioneer	702

### i.LINK Controls

Function	Code
Rewind, Play, Fast-forward, Record, Stop, Pause	901

### DVD Players

Manufacturer	Code
Sony	751
Apex	762
General Electric	755
Hitachi	758
JVC	756
Magnavox	757
Mitsubishi	761
Oritron	759
Panasonic	753
Philips	757
Pioneer	752
RCA/Proscan	755
Samsung	758
Toshiba	754
Zenith	760

### Cable Boxes

Manufacturer	Code
Sony	230
Hamlin/Regal	222, 223, 224, 225, 226
Jerrold/G. I./ Motorola	201, 202, 203, 204, 205, 206, 207, 208, 218
Oak	227, 228, 229
Panasonic	219, 220, 221
Pioneer	214, 215
Scientific Atlanta	209, 210, 211
Tocom	216, 217
Zenith	212, 213

### Satellite Receivers









Manufacturer	Code
Sony	801
Dish Network	810
Echostar	810
General Electric	802
Hitachi	805
Hughes	804
Mitsubishi	809
Panasonic	803
RCA/ PROSCAN	802, 808
Toshiba	806, 807

# Using Other Equipment with Your TV Remote Control





## All Equipment

To Do This ...	Do This ...
Switch the TV's input to the VCR, DVD player, or other connected equipment	Press TV/VIDEO repeatedly to cycle through the video equipment connected to the TV's video inputs.
Set up the TV remote control to operate non-Sony equipment	You must program the remote control the first time you use it. See "Programming the Remote Control" on pages 49 to 50.

## Operating a VCR

To Do This ...	Press
Activate the remote control to operate the VCR	Open the outside cover, as shown on page 48. Then set the A/V slide switch to the position you programmed for the VCR.
Change channels	CH +/-
Record	 and  simultaneously
Play	
Stop	
Fast forward	
Rewind the tape	
Pause	
Search the picture forward or backward	 or  during playback (release to resume normal playback)
Change input mode	TV/VCR

## Operating a Satellite Receiver

To Do This ...	Press
Activate the remote control to operate the satellite receiver	SAT/CABLE FUNCTION
Turn on/off	SAT/CABLE POWER
Select a channel	0-9, ENTER
Change channels	CH +/-
Back to previous channel	JUMP
Display channel number	DISPLAY
Display SAT Guide	GUIDE
Display SAT Menu	MENU
Move highlight (cursor)	Move the joystick    
Select item	

## Operating a Cable Box

To Do This ...	Press
Activate the remote control to operate the cable box	SAT/CABLE FUNCTION
Turn on/off	SAT/CABLE POWER
Select a channel	0-9, ENTER
Change channels	CH +/-
Back to previous channel	JUMP

## Operating a DVD Player

To Do This ...	Press
Activate the remote control to operate the DVD	Open the outside cover, as shown on page 48. Then set the A/V slide switch to the position you programmed for the DVD player.
Play	▶
Stop	■
Pause	⏸
Step through different tracks of the disc	▶▶ to step forward or ◀◀ to step backward
Step through different chapters of a video disc	CH+ to step forward or CH- to step backward
Display the DVD player Menu (Setup)	MENU (inside panel)
Display the DVD Menu	DISC MENU
Move highlight (cursor)	↑ ↓ ◀ ▶
Select item	SELECT

## Operating an MDP (Laserdisc Player)

To Do This ...	Press
Activate the remote control to operate the MDP	Open the outside cover, as shown on page 48. Then set the A/V slide switch to the position you programmed for the MDP player.
Play	▶
Stop	■
Pause	⏸
Search the picture forward or backward	▶▶ or ◀◀ during playback (release to resume normal playback)
Search a chapter forward or backward	CH +/-



# Using the Features



## Overview

This chapter describes how to use the features of your TV.

<i>Topic</i>	<i>Page</i>
Watching TV	54
Using the Scrolling Index	55
Using Wide Mode	56
Using Twin View	57
Using Favorite Channels	60
Using the Freeze Function	61

## Watching TV

 For a complete list of all the functions of the remote control, see pages 45-50.

To Do This ...	Do This ...
Activate the remote control to operate the TV	Press TV FUNCTION
Turn on/off the TV	Press TV POWER
Tune directly to a channel	To tune to analog channels, press 0-9 and then ENTER. For digital subchannels, press 0-9,  , press 0-9 again, and then ENTER. For example, to select subchannel 2.1, press 2 +  + 1, and then press ENTER.
	 <b>You can also select digital channels using the digital program guide. See page 63 for details.</b>
Adjust the volume	Press VOL +/-
Mute the sound	Press MUTING (press again to unmute)
Alternate back and forth between two channels	Press JUMP The TV alternates between the current channel and the last channel tuned.
Display the current channel number (and other information)	Press DISPLAY once to display the channel number, current time, and channel label (if set). Press DISPLAY again to turn Display off.
Switch the TV's input to the VCR, DVD player, or other connected equipment	Press TV/VIDEO repeatedly to cycle through the video equipment connected to the TV's video inputs.
Change video and audio options, customize the TV's setup, set parental controls, and more	Press MENU to display the Menu. For details, see "Using the Menus" on page 91.
Switch the TV's input between sources connected to the TV's VHF/UHF and CABLE inputs	Press ANT to alternate between sources connected to the TV's VHF/UHF and CABLE inputs.
Switch the TV's input to a connected i.LINK device	Press i.LINK to display a list of available i.LINK devices, and select the desired device from the list. See page 86 for details.

## Using the Scrolling Index

The Scrolling Index lets you select programs from a series of preview windows that scroll along the right side of the screen.

- 1 Press INDEX.

The Scrolling Index appears, with the currently selected program in the main (left) window, and four scrolling video pictures in the right.



As each picture on the right scrolls to the live preview window, it changes briefly from a frozen video picture to a live video. The right side continues to scroll through the entire channel list.

- 2 To change the direction of the scrolling, move the joystick  $\uparrow$  or  $\downarrow$ .
- 3 To change the speed of the scrolling, move and hold the joystick  $\uparrow$  or  $\downarrow$ .
- 4 To change a frozen video picture to a live video, move the joystick  $\uparrow$  or  $\downarrow$  to highlight the picture, then press  $\odot$ .
- 5 To move the live video (from step 4) from the right to the main (left) window of the Scrolling Index, press  $\oplus$  again.

To exit the Scrolling Index

- Press INDEX.

### Factors Affecting Scrolling Index

- Scrolling Index feature does not function if you use a cable box to view all channels.
- Digital sources, as well as any sources connected to the VIDEO 5, VIDEO 6, VIDEO 7 inputs, display in the left window, but not in the right windows.
- Scrolling Index does not function if parental controls are set (see page 100).

## Using Wide Mode

Wide Screen mode lets you watch 4:3 normal broadcasts in several Wide Screen modes (16:9 aspect ratio).

 You can also access the Wide Mode settings in the Screen menu. For details, see page 96.

 **When viewing high-definition programs broadcast in 720p/1080i, it is not possible to change between Wide Screen modes.**

- ❑ Press WIDE MODE repeatedly to toggle through the following Wide Mode settings.

### Example

### Description



Wide Zoom



Normal



Full



Zoom

Wide Zoom enlarges the center portion of the 4:3 picture proportionately; however, only the left and right edges of the screen are stretched to fill the 16:9 screen. The picture has a normal appearance, as much as possible.

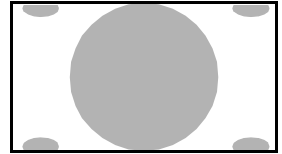

Normal returns the 4:3 picture to its original size. Black bars are visible at left and right sides to fill the 16:9 screen.

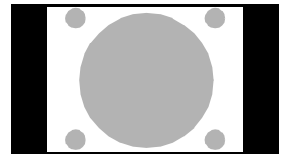

Full Mode stretches the entire 4:3 picture horizontally only, to fill the 16:9 screen. The picture has an elongated appearance.

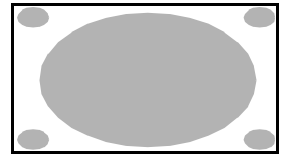

Zoom Mode enlarges the entire 4:3 picture proportionately to fill the 16:9 screen. Useful for watching Letterbox movies.

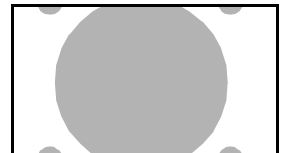

When you change channels or inputs, the Wide Mode settings revert to the 4:3 Default setting in the Screen menu. To retain the current Wide Mode setting as channels and inputs are changed, set 4:3 Default to Off. For details, see page 97.

## Using Twin View

Twin View lets you see two pictures from two sources — from an antenna, VCR, DVD, etc. — on the screen at the same time. You hear the sound from only one of the sources at a time, but you can choose which source's sound is selected. You can also change the relative size of each of the pictures.



### Displaying Twin Pictures

- 1 Tune the TV to a working channel.
- 2 Press .

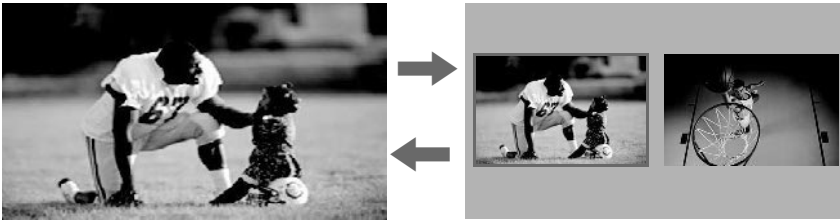
A second picture appears. The active picture is highlighted in blue.



To cancel Twin View and watch the active picture

- Press  or .

### Factors Affecting Twin View

- If you use a cable box to view all channels, the same channel appears in both windows of Twin View because the cable box unscrambles only one channel at a time.
- If you use a cable box, you can view the cable box output in one Twin View window and view a different source (such as a VCR or DVD player) in the second window by using the TV/VIDEO button. For details, see “Connecting Optional Equipment” on page 23.
- Digital sources, as well as any sources connected to the VIDEO 5, VIDEO 6, VIDEO 7 inputs, display in the left window, but not in the right.
- If you are viewing a 4:3 source and a 16:9 enhanced source (such as a DVD) side by side in Twin View, the 4:3 source appears larger.
- Twin View does not display channels that are blocked by parental settings (see page 100).

## Activating the Picture

To activate the picture in the right window



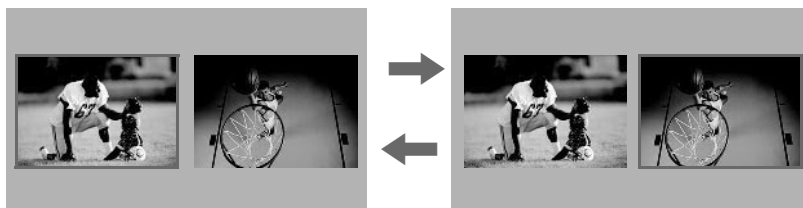

- Move the joystick ➔.

To activate the picture in the left window

- Move the joystick ➜.



### Functions Available in the Active (Highlighted) Window

To Do This ...	Do This ...
Tune directly to a channel	To tune to analog channels, press 0-9 and then ENTER or Press CH+/- For digital subchannels, press 0-9,  , press 0-9 again, and then ENTER. For example, to select subchannel 2.1, press 2 +  + 1, and then press ENTER.
Adjust the volume	Press VOL +/-
Mute the sound	Press MUTING (press again to unmute)
Switch the TV's input between sources connected to the TV's VHF/UHF and CABLE inputs	Press ANT
Switch the TV's input between sources connected to the TV's A/V inputs	Press TV/VIDEO
Change the picture size	Move the joystick  or  . (For details, see "Changing the Picture Size" on page 59.)

## Changing the Picture Size

The zoom feature lets you vary the relative size of the left and right pictures.

- 1 Move the joystick  $\leftarrow$  or  $\rightarrow$  to activate the picture that you want to resize.
- 2 Move the joystick  $\uparrow$  to enlarge the picture.
- 3 Move the joystick  $\downarrow$  to make the picture smaller.

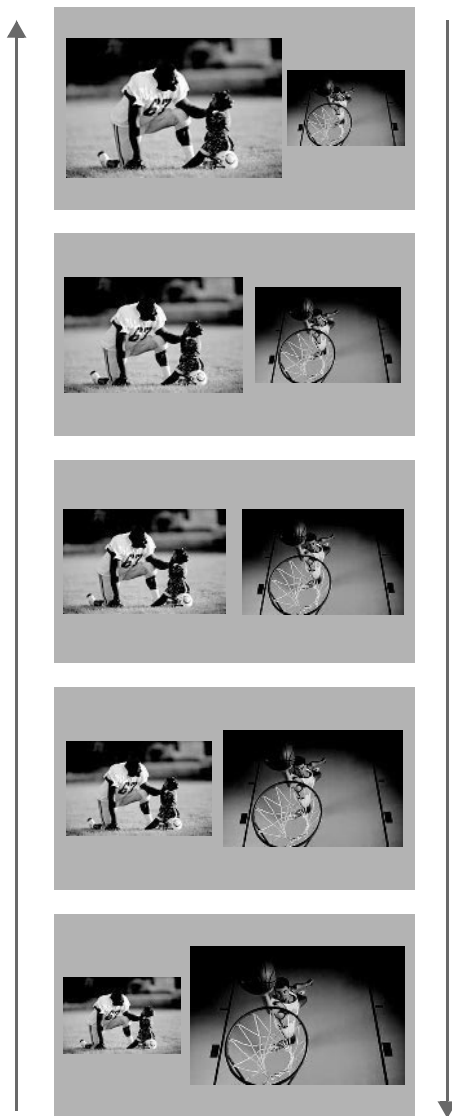

When you adjust the picture sizes, the TV memorizes the change. The next time you use the Twin View function, the memorized sizes appear.

## Using Favorite Channels

The Favorite Channels feature lets you select programs from a list of up to 16 favorite channels that you specify.

### Creating a List of Favorite Channels

 For details on using the Channel Menu, see page 98.

- 1 Press MENU to display the Menu.
- 2 Move the joystick  $\leftarrow$  or  $\rightarrow$  to highlight the Channel icon and press  $\oplus$ .
- 3 Press  $\oplus$  to select Favorite Channels.
- 4 Move the joystick  $\uparrow$  or  $\downarrow$  to highlight a Favorite Channel number (1-16) and press  $\oplus$ .
- 5 Move the joystick  $\uparrow$  or  $\downarrow$  to highlight a channel you want to assign to the Favorite Channel number. A preview of the highlighted channel appears in the upper right of the screen. Press  $\oplus$  to select that channel as a Favorite Channel.

 Digital channels are displayed as a black box in the preview window.

- 6 To add more channels to your favorites list, repeat steps 4-5. To clear a Favorite Channel, move the joystick  $\uparrow$  or  $\downarrow$  to highlight the channel you want to clear. Press  $\oplus$  and then press RESET.
- 7 Press MENU to exit the Menu.

### Displaying a List of Favorite Channels

 To assign Channel Labels (e.g., ABC, HBO, MTV, etc.) to channel numbers, as shown at right, use the Channel Label feature in the Channel Menu (see page 99).

- 1 Press FAVORITES. The Favorite Channels list appears.

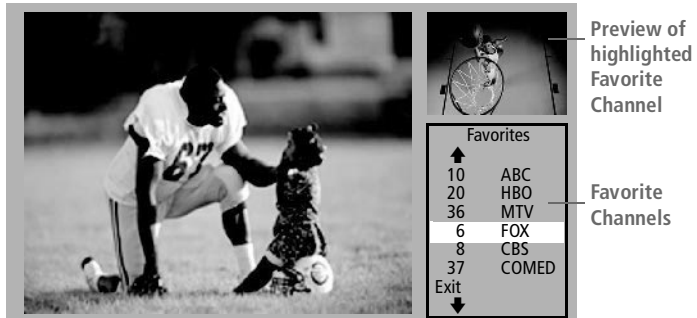

- 2 Move the joystick  $\uparrow$  or  $\downarrow$  to highlight the channel you want to watch. A preview of the highlighted Favorite Channel appears.
- 3 Press  $\oplus$  to select the channel you want to watch.



## Using the Freeze Function

The FREEZE button allows you to temporarily capture a program's picture. You can use this feature to write down information such as phone numbers, recipes, etc.

 **The Freeze feature is not available while you are using the Twin View.**

- 1 When the program information you want to capture is displayed, press FREEZE.
- 2 The TV switches to Twin View mode and displays the "frozen" picture on the right, while the current program continues on the left.



- 3 To cancel and return to normal viewing, press FREEZE (or just tune to another channel).



# Using the Digital Program Guide

## Displaying the Digital Program Guide

This TV is equipped to show digital programming, if a digital signal is present. The digital program guide and menus let you review program information, select digital channels and subchannels, set up your TV's digital programming, and enable digital closed captioning.

 **Analog channels are not available in this guide.**

To display the digital program guide:

- 1 Tune your TV to a digital channel by using the 0-9, , and ENTER buttons.
- 2 Press GUIDE on the TV's remote control. The digital program guide appears, with the currently selected program showing in the background.

 The digital program guide and menus are not available while using multipicture functions (Twin View, Freeze, Scrolling Index, i.LINK, Memory Stick, or Favorite Channels).



 **Program information in the guide is provided by the broadcasters. As a result, it may sometimes include only the channel number, without a program title or description.**

## Navigating the Digital Program Menus

Four digital menus are available on the digital program guide.

Digital Program Menu	See Page
Using the Guide Menu	64
Using the Program Options Menu	64
Using the Caption Vision Menu	65
Using the Digital Setup Menu	65

To navigate to these menus and through the available options:

- 1 Move the joystick  $\uparrow \downarrow \leftarrow \rightarrow$  to navigate through the options.
- 2 Press  $\oplus$  to select the desired option.

## Using the Guide Menu

The Guide menu allows you to select digital channels and subchannels from a dropdown list. This list also provides information about the current program being shown on each digital channel.



 Subchannels are additional channels of programming broadcast simultaneously. For example, channel 4 might include three subchannels (4.1, 4.2, 4.3) that are showing programs at the same time.

## Using the Program Options Menu

The Program Options menu allows you to customize the settings of the program on the currently tuned channel.

Option	Description
Alternate Video	Each program has a main video stream, and may have alternate video streams. This option allows you to switch among these alternate video streams.
Alternate Audio	Each program has a main audio stream (the audio that you hear when the channel is first tuned). This option allows you to switch among these alternate audio streams (e.g., for different languages).

## Using the Caption Vision Menu

The Caption Vision menu allows you to turn on/off digital closed captioning, and to modify how digital closed captioning is shown on your TV. Depending on the program, digital closed captioning will be available in a number of different languages, aspect ratios, and reading levels.

- 1 Use the joystick to select from the following six services. The service description, if available, applies to the currently tuned channel.

Option	Description
Off	Turns off closed captioning for digital programs
1 XXX YYY ZZZ	XXX = language (English, Spanish, French, etc.)
2 XXX YYY ZZZ	YYY = reader level (standard*, easy)
3 XXX YYY ZZZ	ZZZ = aspect ratio (4:3, 16:9)
4 XXX YYY ZZZ	
5 XXX YYY ZZZ	* When set to this option, the option name is not shown
6 XXX YYY ZZZ	



 **The Caption Vision menu only affects digital channels. For closed captioning on analog channels, see “Using the Setup Menu” on page 103.**

## Using the Digital Setup Menu

 This option is the same as the “Digital Channels” option. See “Using the Setup Menu” on page 103.

The Digital Setup menu lets you change the way your digital channels are displayed.

The following digital setup functions are available:

Option	Description
Add Digital Channels	This option allows you to add new digital channels for the currently active antenna mode (Cable or VHF/UHF).  <b>This option is useful if the number of digital channels that your TV is able to receive has recently been increased, but you do not want your TV to perform a full Auto Setup.</b>
Channel Show/Hide	This option allows you to remove (hide) digital channels from the Digital Program Guide’s list of channels and subchannels, as well as from channel surfing using CHANNEL +/- . Hidden channels can still be directly tuned using 0-9 and  .
Digital Signal Strength	Displays the current strength of the digital signal on VHF/UHF, to allow you to adjust your antenna for optimal reception. (Does not apply to digital cable channels.)
Digital Caption Setup	Allows you to customize digital closed captioning (see page 66 for details).

---

## **Customizing Caption Vision**

You can use the Digital Caption Setup menu to customize your TV's Caption Vision.

Select from the following options to change the visual characteristics of your TV's digital closed captioning. A preview window displays a sample as you scroll through each option.

<i>Option</i>	<i>Description</i>
Character Size	Small, Standard*, Large
Character Style	Style 1-7 (Style 4*)
Character Color	None, Color 1-8 (White*)
Edge Color	Color 1-8 (Black*)
Edge Type	None*, Raised, Depressed, Outline, Left Shadow, Right Shadow
Background Color	None, Color 1-8 (Teal, Transparent*)
Window Color	None*, Color 1-8

\* Indicates factory default setting

# Using the Memory Stick Viewer

## About Memory Stick



Memory Stick (sold separately) is a new, compact, portable, and versatile Integrated Circuit recording medium with a data capacity that exceeds that of a floppy disk. Memory Stick is specially designed for sharing digital data among Memory Stick compatible products such as digital cameras and digital video cameras. Because it is removable, Memory Stick can also be used for external data storage.

The Memory Stick Viewer on your TV allows you to view files that are stored on Memory Stick media. You can view:

- Digital photos (JPEG files)
- Movies (MPEG1 files)

You can also play slide show background music using MP3 files stored on your Memory Stick.

For more information about handling Memory Stick media, see “Notes on Using Memory Stick Media” on page 81.

---

## Features

With the Memory Stick Viewer, you can:

- View photo (JPEG) and movie (MPEG1) files in a thumbnail index or Slide Show
- Set customized Slide Show options, including transitions and background audio
- Pan, zoom, and rotate photos
- Lock (protect) or delete files on the Memory Stick

---

## Memory Stick Compatibility

This television is compatible with the following Memory Stick media types:

- Memory Stick Media
- Memory Stick Duo Media
- Memory Stick Media with Memory Select Function
- Memory Stick PRO Media

### About Memory Stick PRO Media

Memory Stick PRO media features vary by and are dependent upon the design of host hardware devices. Memory Stick Pro in this television has been tested to support up to 1 GB media capacity and does not support high-speed transfer, MagicGate copyright protection technology, or access control security features.

---

## File Compatibility

The Memory Stick Viewer is compatible with JPEG images taken with Sony digital still cameras and MPEG1\* movies taken with Sony digital cameras and camcorders. In order to be viewable in the Memory Stick Viewer, the files must have the following file name extensions:

<i>File Type</i>	<i>Supported File Name Extensions</i>
JPEG	.jpg .jpeg
MPEG1	.mpg .mpeg

---

## Trademark Information

Memory Stick, Memory Stick PRO, and MagicGate are trademarks of Sony Corporation.

---

\*Some variations of MPEG1 movies may not play back correctly.





## Inserting and Removing a Memory Stick

If you are using a Memory Stick Duo, see “Inserting the Memory Stick Duo” on page 70.

### Inserting a Memory Stick

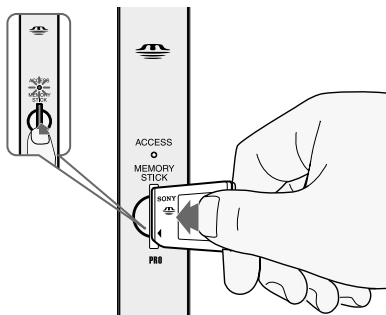
- 1 Locate the Memory Stick slot and insert the Memory Stick into the Memory Stick slot as illustrated below. When inserted properly, it should slide in with little resistance and click into place.



 **Be sure to insert the Memory Stick in the correct direction. If the Memory Stick is forced in the wrong way, it may become damaged.**  
**Insert only Memory Stick media into the Memory Stick slot. Attempting to insert other objects into the slot may damage the TV.**

To remove the Memory Stick, see “Removing a Memory Stick” on page 71.

## Inserting the Memory Stick Duo

Memory Stick Duo is a new, compact version of the standard-sized Memory Stick recording medium.

**!** CAUTION: Inserting the Memory Stick Duo incorrectly may result in permanent damage to the Memory Stick Duo and the TV.

- 1 Before inserting a Memory Stick Duo into the TV's Memory Stick slot, you must first insert the Memory Stick Duo into an adapter (sold separately).

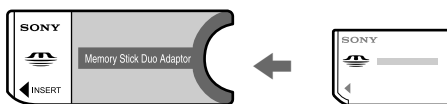

Memory Stick Duo Adapter

Memory Stick Duo

**!** CAUTION: Inserting the Memory Stick Duo into the Memory Stick slot without the adapter may result in permanent damage to the Memory Stick Duo and the TV.

- 2 Insert the Memory Stick Duo and adapter as shown below.

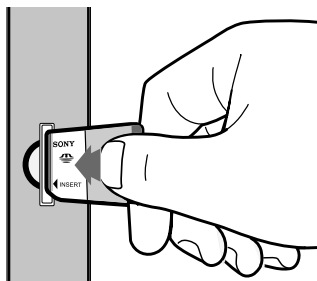

**!** CAUTION: Inserting the Memory Stick adapter backwards or upside down may result in permanent damage to the Memory Stick adapter and the TV.

To remove the Memory Stick Duo, see "Removing a Memory Stick" on page 71.

## Removing a Memory Stick

To remove a Memory Stick

- 1 Check that the Memory Stick indicator is off. (When the light is on, this indicates that the TV is reading data from the Memory Stick.)

 Removing the Memory Stick while a file is being accessed (when the Memory Stick LED on the TV's front panel is lit) may damage the Memory Stick or its contents.

- 2 Push the Memory Stick gently into the slot, and then release it. The Memory Stick media is ejected.

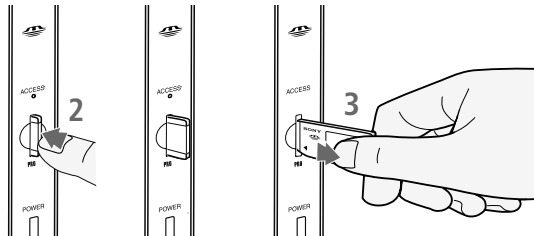

- 3 Pull the Memory Stick completely out of the slot.

 To protect small children from injury from Memory Stick Media, remove all Memory Stick media from the TV's Memory Stick slot and store it in a safe location when it is not in use.

 When removing the Memory Stick, do not attempt to just pull it from its slot. Follow steps 1-3 (right).

## Using the Memory Stick Index

Turn on the TV and insert a Memory Stick that contains the photo or movie files you want to view. For details, see page 69.

 **If the Memory Stick Index does not appear, press the MEMORY STICK button on the remote control.**

The Memory Stick Index appears, which displays thumbnail images of the files stored on the Memory Stick.



### About the Lock and Movie Icons on the Thumbnail Images

 Indicates the thumbnail is a movie (MPEG1) file instead of a photo (JPEG) file.

 Indicates the thumbnail is locked. Locked files cannot be changed or deleted. For details, see "Protect" on page 80.

## Using the Memory Stick Index

The following describes how to use the Memory Stick Index.

To Do This ...	Do This ...
Move the highlight to a photo or movie (Ⓜ) thumbnail	Move the joystick <b>↑ ↓ ← →</b> .
Display the highlighted photo or movie file full screen	Press <b>⊕</b> . For details, see “Viewing Photos” on page 74 and “Playing Movies” on page 77.
Display the next page of thumbnails	<ol style="list-style-type: none"> <li>1 Move the joystick <b>↓</b> to select <b>▼</b>.</li> <li>2 Move the joystick <b>↓</b> to display the next page of thumbnails.</li> </ol>
Display the previous or next page of thumbnails	<ol style="list-style-type: none"> <li>1 Move the joystick <b>↓</b> to select <b>▼</b>.</li> <li>2 Move the joystick <b>←</b> to select <b>◀</b>.</li> <li>3 To go to the previous page, move the joystick <b>←</b>. To go to the next page, move the joystick <b>↓</b>.</li> </ol>
Use the Memory Stick menu bar to access additional options	<ol style="list-style-type: none"> <li>1 Move the joystick <b>↓</b> to select <b>▼</b>.</li> <li>2 Move the joystick <b>←</b> or <b>→</b> to select Slide Show, Folder, or Memory Stick.</li> <li>3 Move the joystick <b>↑</b> or <b>↓</b> to select the option you want to change.</li> </ol> <p>For details on these options, see “Memory Stick Index Menu Bar Options” on page 79.</p>
Move the highlight from the Memory Stick menu bar back to the thumbnails	<ol style="list-style-type: none"> <li>1 Move the joystick <b>←</b> or <b>→</b> to select <b>▼</b>.</li> <li>2 Move the joystick <b>↑</b> to return to the currently displayed thumbnails, or <b>↓</b> to display the next page of thumbnails.</li> </ol>
Exit Memory Stick Viewer	Press the <b>MEMORY STICK</b> button on the remote control.

## Viewing Photos

When you select a photo from the Memory Stick Index (described on page 72), it displays as shown below, with the following controls.



**JPEGs captured using a digital video camera may appear to display motion in full screen. This is a result of the way digital video cameras record still images, and is not a result of a malfunction with the TV.**

### Photo Controls

When the menu is hidden, move the joystick or to go to the previous or next photo.

To Do This ...	Do This ...
Display the next or previous file on the Memory Stick	Move the joystick to highlight the  (Previous/Next) button. Then move the joystick  to go to the previous file, or  to go to the next file.
Hide the Photo menu bar, displaying only the photo	With the highlight in the Photo menu bar, move the joystick .
Display the hidden Photo menu bar	Move the joystick .
Display the Memory Stick Index again	Move the joystick to highlight Index in the Photo menu bar and press . For details on the Memory Stick Index, see page 73.
Access additional options in the Photo menu bar	See "Photo Menu Bar Options" on page 75.
Exit Memory Stick Viewer	Press the MEMORY STICK button on the remote control.

## Photo Menu Bar Options

The Photo menu bar lets you access additional photo viewing options.

To access the Photo menu bar

- 1 Move the joystick ◀ or ▶ to select Slide Show, View, or File.
- 2 Move the joystick to select the desired option.

Option	Description	
Index	Displays the Memory Stick Index, with the highlight on the thumbnail of the currently displayed photo. For details, see "Using the Memory Stick Index" on page 72.	
Slide Show	Displays the Slide Show menu. For details, see "Slide Show Menu Options" on page 79.	
View	Zoom/Pan	Allows you to magnify and pan across the photo. For details, see "Using Zoom and Pan" on page 76.
	Rotate	Allows you to rotate the photo in 90 degree increments clockwise or counterclockwise. For details, see "Using Rotate" on page 76.
File	Information	Allows you to turn on or off the display of file information. Select On or Off.
	Protect	Allows you to the protect the JPEG file from any changes. When a JPEG file is protected, it cannot be rotated or deleted. Select On or Off.
	Delete	Deletes the JPEG file from the Memory Stick. You cannot delete a JPEG file that has been protected (or if the Memory Stick is locked).



JPEG files that are protected are indicated by the Lock icon.

## Using Zoom and Pan

### To Zoom and Pan a photo

- 1 In the Photo menu bar, move the joystick to highlight View.
- 2 Move the joystick to highlight Zoom/Pan and press **+**.
- 3 Specify the zoom center point by moving the joystick; then press **+** to set the center.

The Zoom and Pan controls are displayed.

Indicates Zoom increment



#### To Do This ...

Zoom in (increase magnification) or out (decrease magnification)

#### Do This ...

Move the joystick to highlight Zoom and press **+**. Then move the joystick **↑** to zoom in or **↓** to zoom out.

To stop using Zoom, press **+**.

Pan (left, right, up, down)

(You can use Pan only when the photo is magnified using Zoom.)

Move the joystick to highlight Pan and press **+**. Then move the joystick **← → ↑ ↓** to pan around the photo.

To stop using Pan, press **+**.

Exit the Zoom/Pan controls

Move the joystick to highlight Done and press **+**.

Exit Memory Stick Viewer

Press the MEMORY STICK button on the remote control.

## Using Rotate

### To Rotate a photo

- 1 In the Photo menu bar, move the joystick to highlight View.
- 2 Move the joystick to highlight Rotate.
- 3 To rotate clockwise, move the joystick to highlight Clockwise and press **+**.  
To rotate counterclockwise, move the joystick to highlight Counterclockwise and press **+**.

The photo is rotated 90 degrees each time you press **+**.



## Playing Movies

When you select a movie from the Memory Stick Index (described on page 72), it displays as shown below, with the following controls.



### Movie Controls

 The quality of the movie when enlarged depends on the resolution of the MPEG1 file. See your camera's instruction manual for details.



To Do This ...	Do This ...
Enlarge the movie window	Move the joystick to highlight <b>Enlarge</b> , and then press <b>+</b> . To display the movie controls again, press <b>+</b> . When the movie ends, the movie controls are displayed again.
Play the movie with the movie controls displayed	Move the joystick to highlight <b>▶</b> (Play) and then press <b>+</b> .
Pause the movie	Move the joystick to highlight <b>  </b> (Pause) and then press <b>+</b> .
Display the previous or next file on the Memory Stick	Move the joystick to highlight the <b>◀ ▶</b> (Previous/Next) button. Then move the joystick <b>◀</b> to go to the previous file, or <b>▶</b> to go to the next file.
Hide the Movie menu bar, displaying only the movie	With the highlight in the Movie menu bar, move the joystick <b>↓</b> .
Display the hidden Movie menu bar	Move the joystick <b>↑</b> .
Access additional options in the Movie menu bar	See "Movie Menu Bar Options" on page 78.
Exit Memory Stick Viewer	Press the <b>MEMORY STICK</b> button on the remote control.

## Movie Menu Bar Options

To access the Movie menu bar

- 1 Move the joystick to highlight Index in the Movie menu bar.
- 2 Move the joystick ← or → to select Index, Slide Show, or File.
- 3 Move the joystick to select the desired option.

<i>Option</i>	<i>Description</i>	
Index	Displays the Memory Stick Index, with the highlight on the thumbnail of the currently displayed movie.	
Slide Show	Displays the Slide Show menu. For details, see “Slide Show Menu Options” on page 79.	
File	Information	Determines whether file information is displayed. Select On or Off.
	Protect	Allows you to the protect the MPEG1 file from any changes. When an MPEG1 file is protected, it cannot be deleted. Select On or Off.
	Delete	Deletes the MPEG1 file from the Memory Stick. You cannot delete an MPEG1 file that has been protected (or if the Memory Stick is locked).

 MPEG1 files that are protected are indicated by the Lock  icon.

## Memory Stick Index Menu Bar Options

### Slide Show Menu Options

 The Slide Show menu is the same whether you select it from the Memory Stick Index (page 72), Photo (page 74), or Movie (page 77) menus.



 When you select Complete List, it may take a moment to display the list of all MP3 files.

 Some JPEG files may take longer to display than others, which may make it seem longer than the interval you selected for Slide Duration.

The Slide Show menu includes the following options:

Option	Description
Start	Starts the Slide Show.
Music	Allows you to select background audio to play during the Slide Show.
Off	No additional background audio is played during the Slide Show. Audio that is associated with the JPEG or MPEG1 files will play.
Play All	Plays all MP3 files on the Memory Stick. The Piano MP3 file is not played.
Piano	Plays the MP3 file stored in the TV's internal memory. (This file is indicated by a different color than the MP3 files on the Memory Stick.)
(List of MP3 Files)	Displays a list of all MP3 files found at the top level (root) of the Memory Stick. To show additional MP3 files stored in other folders on the Memory Stick, select Complete List.
Complete List	Displays a list of all available MP3 files. The list is sorted in alphabetical order, grouped by folder.
Transition Effect	Allows you to select an effect to be used when advancing to the next file in the Slide Show.
Off	Uses a quick change, or cut.
Fade	Uses a cross fade.
Wipe →	Uses a linear sweep that moves across the screen, revealing the next image while covering the previous image.
Wipe ←	
Wipe ↑	
Wipe ↓	
Random	Randomly cycles through all Transition Effects.
Slide Duration	Allows you to specify a timed slide advance after a selected time interval. Select from 3 sec, 5 sec, 10 sec, 30 sec, 1 min, 5 min.
Repeat	On Slide Show continuously loops.
	Off Slide Show plays once through all files and ends.

## Folder Menu Options

 Files that are protected are indicated by the Lock  icon.

 The Rotate and Protect functions do not change the file's modification date.

The Folder menu includes the following options:

Option	Description
Select Contents	Allows you to select different folders to view in the Memory Stick Viewer.
Digital Camera Folders	Selects all folders within the directories defined by the DCF rules used by Sony digital cameras (see page 81). JPEG and MPEG1 files in those directories are recognized even if they do not conform to the DCF file naming rules.
Select a Folder	Allows you to access individual folders on the Memory Stick.
Protect	Allows you to protect files from any changes. When a file is protected, it cannot be rotated or deleted. The Protect options affect files currently shown in the Memory Stick Index.
Protect All	Protects all files.
Protect None	Unprotects all files.
File Order	Allows you to change the order in which the Memory Stick files are displayed.
Date Order	Displays files in chronological order by modification date.
Date Order Reverse	Displays files in reverse chronological order by modification date.
Alphabetical	Displays files in alphabetical order by filename.
Filter	Allows you to selectively display specific file types within the selected folder.
Show All	Displays all readable files.
Show Photos Only	Displays only photo (JPEG) files.
Show Movies Only	Displays only movie (MPEG1) files.

## Memory Stick Menu

The Memory Stick menu displays the current status of the Memory Stick, including total capacity, used capacity, and free capacity.

## Notes on Using Memory Stick Media

---

### **About DCF File Names**

Most Sony brand digital still and video cameras automatically record still photo and movie files using DCF compliant directory and file names.

If you selected the *Digital Camera Folders* option, as described on page 80, you might want to have your digital camera's instruction manual handy in order to check how files and directories are organized for your specific model of digital camera.

DCF stands for "Design Rules for Camera File Systems," which are specifications established by the Japan Electronic Industry Development Association (JEIDA).

## Memory Stick Precautions

When using Memory Stick media, follow these precautions:

- To avoid permanent damage to still image data, do not turn off the TV or remove Memory Stick media from the insertion slot while data is being read (as indicated by the Memory Stick indicator light being on).
- Avoid touching the terminal of Memory Stick media or bringing it into contact with a metal object.
- Do not drop, bend, or submit Memory Stick media to external shock.
- Do not disassemble or modify Memory Stick media.
- Avoid getting liquid on Memory Stick media.
- Apply labels only within the designated label area.

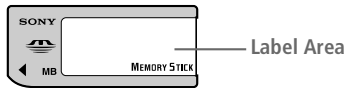

- To avoid permanent damage to still image data, do not use or store Memory Stick media in a location subject to:
  - High temperature (such as near a heater or inside a hot car)
  - High humidity
  - Direct sunlight
  - Corrosive substances
  - Magnetic fields
  - Excessive dust
  - Static electricity or electric noise
  - Electric surges
- Store and carry Memory Stick media in its original case to ensure protection of stored data.
- Save a backup of stored data.

# Using i.LINK

## About i.LINK

This TV is equipped with i.LINK, which provides a secure digital interface to other digital home entertainment devices, such as digital VCRs, digital camcorders, set-top boxes, and other devices that also are equipped with i.LINK. i.LINK allows for the secure transfer of copyright-protected digital content between these devices and your digital television.

i.LINK is a trademark of Sony Corporation and used only to designate that a product contains an IEEE 1394 connector.

All products with an i.LINK connector may not communicate with each other.

---

## Using i.LINK Cables

This TV has three S400 i.LINK terminals (one in the front panel, and two in the back panel). You can use the following i.LINK cables with this TV:

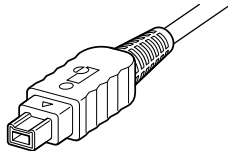

4-pin i.LINK cable

<b>Sony Model</b>	<b>Length</b>
VMC-IL4415	1.5 meters
VMC-IL4435	3.5 meters

 Do not use cables other than the ones listed above.

## Connecting i.LINK Devices

 Before connecting this unit to i.LINK-compatible equipment, read the instruction manual of the i.LINK device to be connected.

To connect a digital i.LINK device (using only a digital signal)

- 1 Using an i.LINK cable (see page 83), connect the device's i.LINK jack to either of the TV's i.LINK jacks.

To connect an i.LINK device that supports an EIA-775A connection

- 1 Using an i.LINK cable (see page 83), connect the device's i.LINK jack to either of the TV's i.LINK jacks.
- 2 Using an A/V cable, connect the i.LINK device's A/V output jacks to the TV's VIDEO 3 A/V input jacks.

 Only one i.LINK cable should connect the TV and any given i.LINK device.

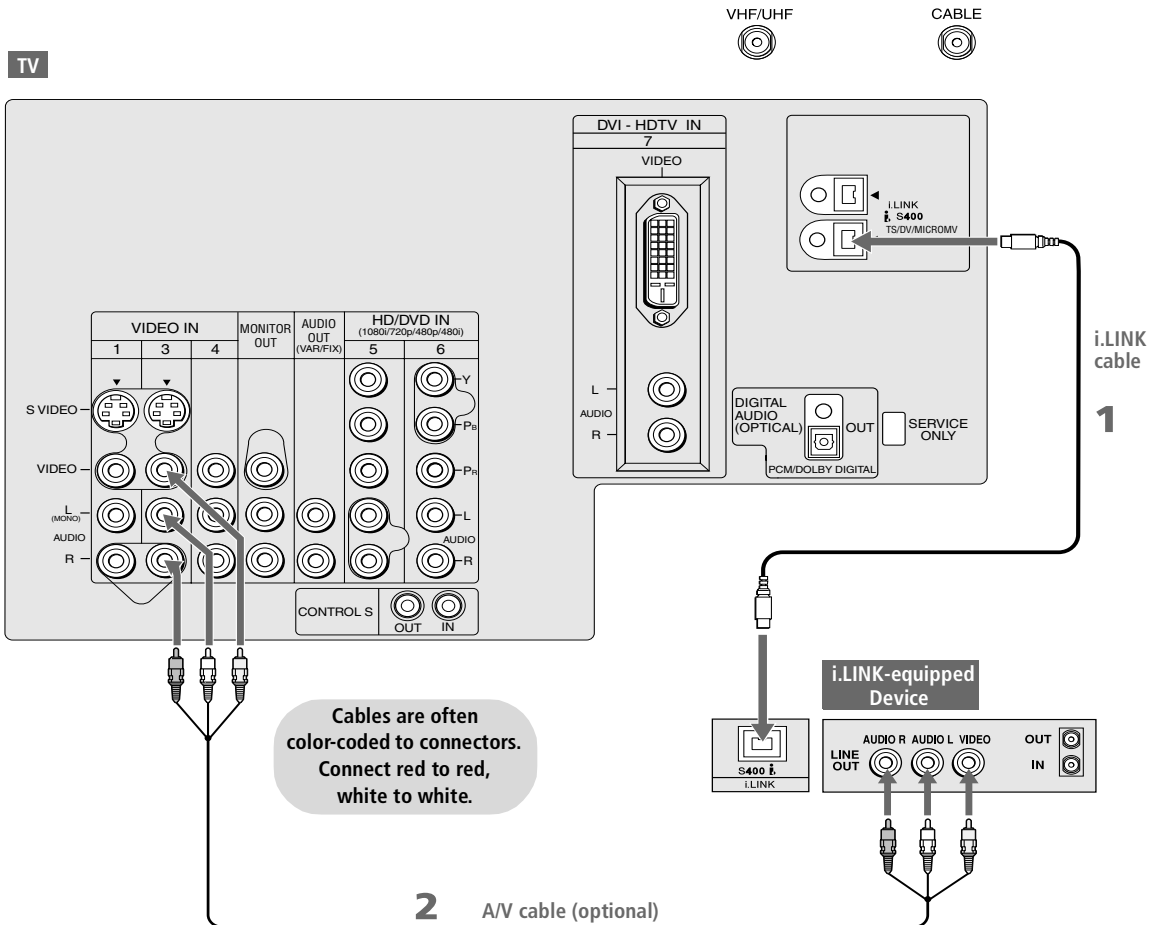



## Notes on Using This Connection

To Do This ...	Do This ...
Set up a digital i.LINK device	For digital i.LINK devices (devices that require only the i.LINK connection), no setup is necessary. The TV automatically recognizes the device as soon as the connection is made.
Set up an i.LINK device that supports an EIA-775A analog connection	<ul style="list-style-type: none"><li>❑ Connect analog A/V cables to the VIDEO 3 input (see page 84).</li><li>❑ Use the i.LINK Control Panel to activate the analog connection to your i.LINK device (see page 89).</li></ul>

## Notes on Connecting i.LINK Devices

To connect two or more i.LINK devices, use i.LINK cables to connect them as shown below.

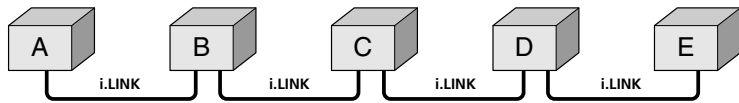

You can connect up to 63 i.LINK devices. However, the maximum number of cables in any serial route is 16.

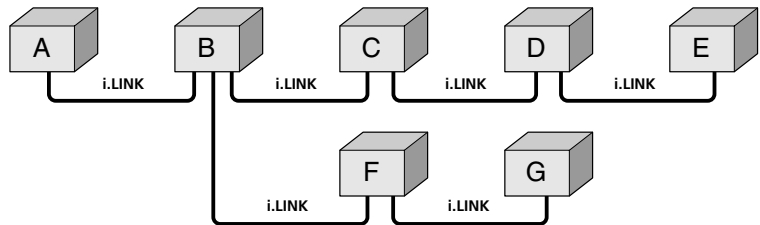

Do not connect i.LINK devices in a way that creates a loop.

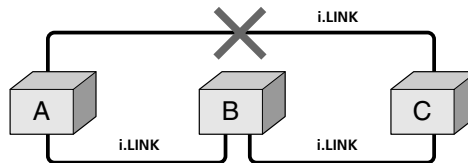

Connecting non-compatible devices, such as PCs or PC peripherals, may result in malfunctions.

## Selecting an i.LINK Device

Before an i.LINK device can be viewed, it must first be selected via the i.LINK Device List.

- 1 Connect the i.LINK device that you wish to operate.



 For instructions on connecting i.LINK devices, see page 84.

- 2 Press i.LINK on the remote control.





The TV (DTV), along with all devices connected by i.LINK to the TV, appear on the Device List.

Devices that are not supported by the TV appear on the Device List as “Other Device,” but cannot be controlled using the TV’s remote control or on-screen i.LINK Control Panel. For these devices, use the remote control supplied with the device.

- 3 Move the joystick  or  to navigate among the i.LINK-connected devices.

 i.LINK devices can be connected to one another and to the TV while the TV is powered on. The Device List will automatically update to include the newly-connected device. See page 84 for more information on connecting i.LINK devices.



- 4 Press  to select the desired device and display the device's i.LINK Control Panel. Use the i.LINK Control Panel to operate the selected device. For details, see page 87.





 i.LINK functions are not available while using the following TV features: Twin View, Freeze, Scrolling Index, and Memory Stick.

## Using the i.LINK Control Panel

After you select an i.LINK device using the Device List, the TV displays the i.LINK Control Panel, which allows you to use the TV's remote to control the selected i.LINK device.

- 1 If the i.LINK Control Panel is not already displayed, press i.LINK on the remote control.

 If i.LINK is pressed while the TV is displaying an analog or digital channel (not the i.LINK device), then the Device List will appear. Select the desired device from the list and press  to display the Control Panel.







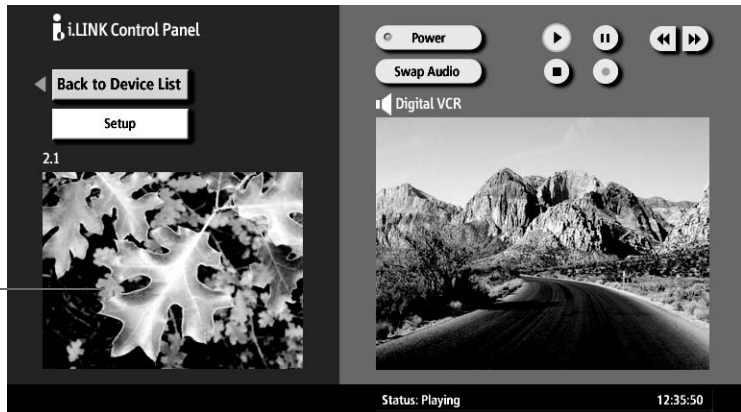







- 2 Move the remote control's joystick     to navigate through the options available in the i.LINK Control Panel.
- 3 Press  to select a desired option.
- 4 Press EXIT to exit the Control Panel and view the i.LINK device full-screen.

 To exit i.LINK mode, select DTV from the Device List or press CH+/-.

The DTV window appears only if the i.LINK menus were entered while watching a digital TV channel



The i.LINK Control Panel displays the signal from the TV to the left (if available), and the signal from the currently selected device to the right.

To Do This ...	Do This ...
Go to the Device List	Move the joystick to highlight Back to Device List and press  .
Change the audio being played from the TV to the current selected device, and vice versa	Move the joystick to highlight Swap Audio and press  . An icon appears next to the window that currently has sound.
Play a recording from the selected i.LINK camcorder or digital VCR	Move the joystick to highlight  and press  .
Fast-forward or rewind a recording from the selected i.LINK camcorder or digital VCR	Move the joystick to highlight  or  and press  .
Record from TV to the selected i.LINK digital VCR	If the  (record) button is available, move the joystick to highlight  and press  .
Stop a recording from the selected i.LINK digital VCR	Move the joystick to highlight  and press  .
Turn the selected device power on and off	Move the joystick to highlight Power and press  .
Setup the selected device	Move the joystick to highlight Setup and press  . For more details on Setup, see page 89.

### Notes About Controlling i.LINK Devices

- ❑ You can control the functions of the selected i.LINK device by using the equivalent buttons on the TV's remote control. To program the remote control to operate i.LINK devices, see "Programming the Remote Control" on page 49.
- ❑ Some options on the i.LINK Control Panel may not be available, depending on the device being controlled.
- ❑ Only i.LINK-equipped digital camcorders and digital VCRs can be controlled directly through the i.LINK Control Panel.
- ❑ Not all functions are supported for all i.LINK devices.

## i.LINK Setup

You can use the i.LINK Control Panel to access digital setup options, some of which are also available through the Digital Program Guide (described on page 63).

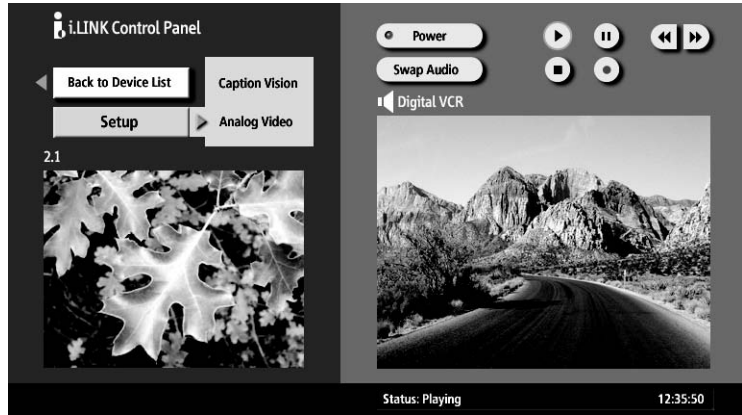

### To Do This ...

Set up the selected device

Set up Caption Vision

Set up i.LINK Analog Video  
(Set-Top Box)

### Do This ...

Move the joystick to highlight Setup and press  $\oplus$ .

Once i.LINK Setup has been selected, move the joystick to Caption Vision, and press  $\oplus$ .

 For details about setting up Caption Vision, see "Using the Caption Vision Menu" on page 65.

The TV is able to accept an analog signal from a selected set-top box. The set-top box must be EIA-775A compliant and must be connected to the TV's VIDEO 3 input. To associate the device with the TV's analog VIDEO 3 input, move the joystick to Analog Video and press  $\oplus$ . All EIA-775A-compliant devices will be shown in the list. Select the desired device from the list and press  $\oplus$ .

### Notes on i.LINK







- ❑ The TV can act as an i.LINK repeater, so that i.LINK signals can be relayed to another device even when the TV is powered off. To enable this feature, set the i.LINK Standby option to On using the Setup Menu as described on page 103.
- ❑ Parental Control settings apply to the signal from a selected device. For more details, see page 100.



# Using the Menus

## Overview

The Menu gives you access to the following features:

Menu Icon	Description	Page
	Allows you to make adjustments to your picture settings. It also allows you to customize the Picture Mode based on the type of program you are viewing, select Advanced Video options, and more.	92
	Offers enhanced audio options such as listening to second audio programming (SAP) or customizing the Effect of the sound on your TV.	94
	Allows you to make Wide Mode adjustments and make changes to the screen's vertical center.	96
	Allows you to set up a Favorite Channel list, run the Auto Program function, skip and label channels, and more.	98
	Lets you control the viewing of programs based on their ratings.	100
	Provides options for setting up your system, including selecting closed caption modes, setting the Timer, labeling video inputs, selecting the language of the on-screen menus, and more.	103

 Press MENU to enter and exit Menus.

## Navigating Through Menus

To Do This ...	Press
Display the Menu	MENU
Move through the Menu	← →
Move through the Menu options	↑ ↓
Select an option to change	⊕
Change an option's settings	↑ ↓ ← →
Select (confirm) changed setting	⊕ or ←
Exit the Menu	MENU

 Menus include navigation help text that appears at the bottom of each Menu.



## Using the Video Menu

To select the Video Menu

- 1 Press MENU.
- 2 Move the joystick ← or → to highlight the Video icon and press Ⓢ.
- 3 Move the joystick to highlight an option. Press Ⓢ to select an option.
- 4 Move the joystick ↑ ↓ ← → to change settings. Press Ⓢ to select the changed setting.
- 5 Press MENU to exit the Menu.

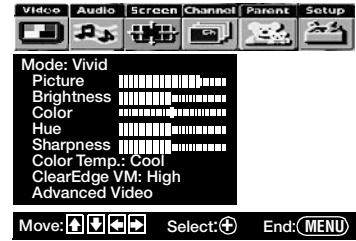

To restore the factory default settings for the Video settings (excluding Advanced Video) of the Mode (Vivid, Standard, etc.) the TV is set to:

- ❑ Press RESET on the remote control when in the Video Menu.

### Selecting Video Options

To change from one Mode to another, use the PIC MODE button on the remote control.

You can alter the Video Menu settings (Picture, Brightness, Color, etc.) for each Mode.

The Video Menu includes the following options:





Option	Description	
Mode	Vivid	
<i>Customized picture viewing</i>	Standard	Select for enhanced picture contrast and sharpness.
	Movie	Select for standard picture settings.
	Pro	Select to display a film-like picture.
		Select to display a picture with minimum enhancements.
Picture	Adjust to increase picture contrast and deepen the color, or decrease picture contrast and soften the color.	
Brightness	Adjust to brighten or darken the picture.	
Color	Adjust to increase or decrease color intensity.	
Hue	Adjust to increase or decrease the green tones.	
Sharpness	Adjust to sharpen or soften the picture.	
Color Temp. <i>White intensity adjustment</i>	Cool	Select to give the white colors a blue tint.
	Neutral	Select to give the white colors a neutral tint.
	Warm	Select to give the white colors a red tint (NTSC-Standard).
ClearEdge VM <i>Velocity Modulation</i>	Sharpens picture definition to give every object a sharp, clean edge. Select from High, Medium, Low, Off.	





 To change quickly from one DRC Mode to another, use the DRC MODE button on the remote control.

 Advanced Video options are not available (grayed out) when watching 480p, 720p, and 1080i sources.

 To change quickly from one DRC Palette to another, use the DRC PALETTE button on the remote control.

 For best results, adjust the Reality by moving the joystick   until you are satisfied with the level of detail. Then adjust the Clarity by moving the joystick   until you have a smooth image.

Option	Description
Advanced Video	Select Program to choose among the DRC Mode and DRC Palette options while viewing NTSC sources.
DRC Mode	Creates a high-resolution picture with 4x density, for high quality sources (i.e., DVD player, satellite receiver).
Interlaced	Recommended for moving pictures.
Progressive	Recommended for still images and text.
CineMotion	Provides an optimized display by automatically detecting film content and applying a reverse 3-2 pulldown process. Moving pictures will appear clearer and more natural-looking.
DRC Palette	<p>Allows you to customize the level of detail (Reality) and smoothness (Clarity) for up to three input sources. For example, you can create one Custom setting to optimize your cable input's picture, and create another to optimize your DVD player's picture. You can switch among the three Custom settings using the DRC PALETTE button on the remote control.</p> <ol style="list-style-type: none"> <li>1 Move the joystick to highlight Custom 1, Custom 2, or Custom 3 and then press . The DRC Palette appears.</li> <li>2 Move the joystick to adjust the position of the marker (●). As you move the ● higher along the Reality axis, the picture becomes more detailed. As you move the ● to the right along the Clarity axis, the picture becomes smoother.</li> <li>3 To save the setting, press .</li> </ol> <p>To return the Custom options to the default factory settings, press the RESET button.</p>

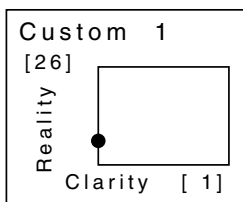



## Using the Audio Menu

To select the Audio Menu

- 1 Press MENU.
- 2 Move the joystick ← or → to highlight the Audio icon and press Ⓢ.
- 3 Move the joystick to highlight an option. Press Ⓢ to select an option.
- 4 Move the joystick ↑ ↓ ← → to change settings. Press Ⓢ to select the changed setting.
- 5 Press MENU to exit the Menu.



To restore the factory default settings for Treble, Bass, and Balance

- Press RESET on the remote control when in the Audio Menu.

### Selecting Audio Options

The Audio Menu includes the following options:

Option	Description
Treble	Adjust to decrease or increase higher-pitched sounds.
Bass	Adjust to decrease or increase lower-pitched sounds.
Balance	Adjust to emphasize left or right speaker balance.
Steady Sound	On Select to stabilize the volume.
	Off Select to turn off Steady Sound.
Effect	TruSurround Select for surround sound (for stereo programs only).
	Simulated Adds a surround-like effect to mono programs.
	Off Normal stereo or mono reception.
MTS <i>Enjoy stereo, bilingual and mono programs</i>	Stereo Select for stereo reception when viewing a program broadcast in stereo.
	Auto SAP Select to automatically switch the TV to second audio programs when a signal is received. (If no SAP signal is present, the TV remains in Stereo mode.)
	Mono Select for mono reception. (Use to reduce noise during weak stereo broadcasts.)
BBE	On Select to give sound more impact by compensating for phase effects in speakers.
	Off Select for normal stereo or mono reception.

 To change quickly from one Effect to another, use the Ⓢ button on the inside panel of the remote control.

<i>Option</i>	<i>Description</i>	
Speaker	On	Select to turn on the TV speakers.
	Off	Select to turn off the TV speakers and listen to the TV's sound only through your external audio system speakers.
Audio Out <i>Easy control of volume adjustments</i>	This option can be set only when the <i>Speaker</i> option is set to Off.	
	Variable	The TV's speakers are turned off, but the audio output from your audio system can still be controlled by the TV's remote control.
	Fixed	The TV's speakers are turned off and the audio output of the TV is fixed. Use your audio receiver's remote control to adjust the volume (and other audio settings) through your audio system.



## Using the Screen Menu

To select the Screen Menu

- 1 Press MENU.
- 2 Move the joystick ← or → to move to the Screen icon and press ⊕.
- 3 Move the joystick ↑ or ↓ to move to an option. Press ⊕ to select an option.
- 4 Move the joystick ← → ↑ ↓ to change settings. Press ⊕ to select the changed setting.
- 5 Press MENU to exit the Menu.



### Selecting Screen Mode Options

 To change from one Wide Mode to another, use the WIDE MODE button on the remote control.

 For Wide Zoom and Zoom modes, you can adjust the vertical position of the picture. For details, see page 97.



The Screen menu includes the following options:

Option	Description
Wide Mode <i>Select a Wide Mode to use for 4:3 sources</i>	Wide Zoom Select to enlarge the 4:3 size picture, while the upper and lower parts of the picture are condensed to fit the wide screen.
Normal	Select to return the 4:3 picture to a 4:3 aspect ratio.
Full	Select to enlarge the 4:3 picture horizontally only, to fill the wide screen.
Zoom	Select to enlarge the 4:3 picture horizontally and vertically to an equal aspect ratio that fills the wide screen.

Wide Mode is unavailable while in Twin View, or when viewing HD (1080i, 720p) sources.

 **In some cases, wide-screen programs will be shown in aspect ratios that require the display of black bands at the top and bottom of your 16:9 screen. For more details, see page 113.**

 If 4:3 Default is set to anything but Off, the Wide Mode setting changes only for the current channel. When you change channels (or inputs), Wide Mode is automatically replaced with the 4:3 Default setting. To retain the current Wide Mode setting as channels and inputs are changed, set 4:3 Default to Off.

<b>Option</b>	<b>Description</b>	
4:3 Default <i>Select the default Screen Mode to use for 4:3 sources</i>	Wide Zoom	Select to enlarge the 4:3 size picture, while the upper and lower parts of the picture are condensed to fit the wide screen.
	Normal	Select to return the 4:3 picture to normal mode.
	Full	Select to enlarge the 4:3 picture horizontally only, to fill the wide screen.
	Zoom	Select to enlarge the 4:3 picture horizontally and vertically to an equal aspect ratio that fills the wide screen.
	Off	Select to continue using the current Wide Mode setting when the channel or input is changed.
Vertical Center	<p>Allows you to move the position of the picture up and down in the window. (Available only in Wide Zoom and Zoom modes.)</p> <p>Move the joystick  or  and press  to choose a correction between +15 and -15 (Zoom mode), and +10 and -10 (Wide Zoom mode).</p>	



## Using the Channel Menu

To select the Channel Menu

- 1 Press MENU.
- 2 Move the joystick ← or → to highlight the Channel icon and press ⊕.
- 3 Move the joystick to highlight an option. Press ⊕ to select an option.
- 4 Move the joystick ↑ ↓ ← → to change settings. Press ⊕ to select the changed setting.
- 5 Press MENU to exit the Menu.



### Selecting Channel Options

The Channel Menu includes the following options:

Option	Description
Favorite Channels	Lets you set up a list of your favorite channels. For details, see “Using Favorite Channels” on page 60.
Channel Fix	Off Turns off Channel Fix.
<i>Useful when you have a cable box or satellite receiver connected</i>	2-6 “Fix” your TV’s channel setting to 2-6 and use the cable box or satellite receiver to change channels. Select one of these settings if you connected the equipment to the VHF/UHF jack.
	Cable 2-6 Same as 2-6, except you select one of these settings if you connected the equipment to the CABLE jack (see page 17).
	Video 1 Use this setting if you have connected the equipment to the A/V input jacks.
Auto Program	Automatically sets up the channel list on the TV for all receivable channels. <b>⚠ Auto Program may take several minutes. A progress bar will display the approximate progress of the Auto Program and Digital Channel Add sequences.</b>
Digital Channel	Add Select to add digital channels.
Channel Skip/Add	Allows you to customize the analog channels that appear when you use the CH+/- buttons. <ol style="list-style-type: none"> <li>1 Move the joystick ↑ or ↓ to scroll through the channels until you find the channel you want to skip or add. Then press ⊕ to select it.</li> <li>2 Move the joystick ↑ or ↓ to toggle between Add or Skip. Then press ⊕ to select.</li> <li>3 To add or skip more channels, repeat steps 1 and 2.</li> <li>4 Move the joystick ← to return to the Channel Menu, or press MENU to exit the Menus.</li> </ol>

Channels that you set to be skipped can be accessed only by direct (0-9 buttons) tuning.

<i>Option</i>	<i>Description</i>
Channel Label	<p>Allows you to assign labels (such as station call letters) to channel numbers. You can label up to 40 channels.</p> <ol style="list-style-type: none"><li>1 Move the joystick to highlight Channel and press ⊕.</li><li>2 Move the joystick ↑ ↓ to scroll through the channel numbers. Then press ⊕ to select the channel number that you want to assign a label.</li><li>3 Move the joystick to highlight Label and press ⊕.</li><li>4 Move the joystick ↑ ↓ to scroll through the label characters (A-Z, 0-9, etc.). Then press ⊕ to select the highlighted character.</li><li>5 Repeat to add up to 5 characters to the label.</li><li>6 To assign labels to more channels, repeat steps 1-4.</li><li>7 Move the joystick ← to return to the Channel Menu, or press MENU to exit the Menus.</li></ol>

---



## Using the Parent Menu

The Parent Menu allows you to set up the TV to block programs according to their content and rating levels.



To select the Parent Menu

- 1 Press MENU.
- 2 Move the joystick **←** or **→** to highlight the Parent icon and press **⊕**.
- 3 Use the 0-9 buttons on the remote control to enter a four-digit password.
- 4 If this is the first time you are creating this password, confirm the password by entering it again. (The Parent Menu options appear.)
- 5 Move the joystick **↑** **↓** **←** **→** to change settings. Press **⊕** to select the changed setting.
- 6 Press MENU to exit the Menu.

You need your password for any future access into the Parent Menu. If you lose your password, see "Lost password" on page 114.

### Selecting Parent Options

If you are not familiar with the Parental Guideline rating system, you should select Child, Youth, or Young Adult to help simplify the rating selection. To set more specific ratings, select Custom.

For descriptions of Child, Youth, and Young Adult ratings, see page 101.

The Parent Menu includes the following options:

Option	Description
Parental Lock	Off Parental lock is off. No programs are blocked from viewing.
Turn ratings on/off and select a rating system	Child Maximum ratings permitted are: <input type="checkbox"/> US: TV-Y, TV-G, G <input type="checkbox"/> Canada: C, G, TV-Y
	Youth Maximum ratings permitted are: <input type="checkbox"/> US: TV-PG, PG <input type="checkbox"/> Canada: C8+, PG, 8 ans+, TV-PG
	Y. Adult Maximum ratings permitted are: <input type="checkbox"/> US: TV-14, PG-13 <input type="checkbox"/> Canada: 14+, 13 ans+, TV-14
	Custom Select to set ratings manually. <input type="checkbox"/> US: See page 101 for details. <input type="checkbox"/> Canada: See page 102 for details.
Change Password	For changing your password.
Select Country	U.S.A. Select to use USA ratings (see page 101).
	Canada Select to use Canadian ratings (see page 102).



## US Models: Selecting Custom Rating Options

 The Content-Based Ratings are linked to the level of the Age-Based Rating. For example, a program with an Age-Based Rating of TV-PG V (Violence) rating may contain moderate violence, while a TV-14 V (Violence) rating may contain more intense violence.

 To ensure maximum blocking capability, set the Age-Based Ratings.

 If you block unrated TV programs, be aware that the following types of programs may be blocked: programs broadcast from another country, emergency broadcasts, political programs, sports, news, public service announcements, religious programs and weather.

For US models, the Custom Rating Menu includes the following options. (For Canadian models, see page 102.)

Option	Description
Movie Rating	G All children and General Audience.
	PG Parental Guidance suggested.
	PG-13 Parental Guidance for children under 13.
	R Restricted viewing, parental guidance is suggested for children under 17.
	NC-17 and X No one 17 or under allowed.
TV Rating	<b>Age-Based Ratings</b>
<i>Block programs by their rating, content or both</i>	TV-Y All children.
	TV-Y7 Directed to children age 7 and older.
	TV-G General Audience.
	TV-PG Parental Guidance suggested.
	TV-14 Parents Strongly cautioned.
	TV-MA Mature Audience only.
	<b>Content-Based Ratings</b>
	FV Fantasy Violence.
	D Suggestive Dialogue.
	L Strong Language.
	S Sexual situations.
	V Violence.
Unrated <i>Block programs or movies that are broadcast without a rating</i>	Block Blocks all programs and movies that are broadcast without a rating.
	Allow Allows programs and movies that are broadcast without a rating.

## Viewing Blocked Programs

You can view blocked programs by entering the password. Press the ENTER button when tuned to a blocked program, then enter the password. This temporarily switches off the Parental Lock. To reactivate the Parental Lock settings, turn off the TV. When the TV is turned on again, your Parental Lock settings are reactivated.

## Canadian Models: Selecting Custom Rating Options

For Canadian models, the Custom Rating Menu includes the following options. (For US models, see page 101.)

<i>Option</i>	<i>Description</i>	
English Rating	C	All children.
	C8+	Children 8 years and older.
	G	General programming.
	PG	Parental Guidance.
	14+	Viewers 14 and older.
French Rating	18+	Adult programming.
	G	General programming.
	8 ans+	Not recommended for young children.
	13 ans+	Not recommended for ages under 13.
U.S.A. Rating	16 ans+	Not recommended for ages under 16.
	18 ans+	Programming restricted to adults.
	See "US Models" on page 101 for details.	

## Viewing Blocked Programs

You can view blocked programs by entering the password. Press the ENTER button when tuned to a blocked program, then enter the password. This temporarily switches off the Parental Lock. To reactivate the Parental Lock settings, turn off the TV. When the TV is turned on again, your Parental Lock settings are reactivated.



## Using the Setup Menu

To select the Setup Menu

- 1 Press MENU.
- 2 Move the joystick ← or → to highlight the Setup icon and press ⊕.
- 3 Move the joystick to highlight an option. Press ⊕ to select an option.
- 4 Move the joystick ↑ ↓ ← → to change settings. Press ⊕ to select the changed setting.
- 5 Press MENU to exit the Menu.







### Selecting Setup Options



















 Caption Vision options in the Setup Menu apply only to analog programs. To set up closed captioning for digital programs, see “Using the Caption Vision Menu” on page 65.

The Setup Menu includes the following options:







Option	Description
Caption Vision	Allows you to select from three closed caption modes (for programs that are broadcast with closed caption).
CC1, CC2, CC3, CC4	Displays a printed version of the dialog or sound effects of a program. (Should be set to CC1 for most programs.)
Text1, Text2, Text3, Text4	Displays network/station information presented using either half or the whole screen (if available). For closed captioning, set to CC1.
Info	Displays the program name and the time remaining in the program (if the broadcaster offers this service). Displays when the channel is changed or the DISPLAY button is pressed.
Off	Turns off Caption Vision.

 The Skip label is useful for inputs that do not have equipment connected to them.

 To go directly to programming Timer 1 or 2, press  instead of moving the joystick .

Option	Description								
Video Label	<p>Allows you to identify A/V equipment you connected to the TV, such as a VCR, DVD, etc. For example, if you have a DVD player connected to the VIDEO 5 jack, you can select the label DVD for the VIDEO 5 input. Then when you press the TV/VIDEO button to change inputs, the Video Label you assigned to that input appears on screen.</p> <ol style="list-style-type: none"> <li>1 Move the joystick  or  to highlight the video input (VIDEO 1-7) to which you want to assign a label. Then press  to select the input.</li> <li>2 Move the joystick  or  to highlight one of the displayed labels. Then press  to select the label.</li> </ol> <p>You can select from the following labels for each input:</p> <table border="1"> <tr> <td data-bbox="618 477 860 546">Video 1/2/3/4</td> <td data-bbox="860 477 1259 546">VHS, DVD, Receiver, Satellite, Cable Box, 8mm, DTV, LD, Beta, Skip</td> </tr> <tr> <td data-bbox="618 546 860 581">Video 5/6/7</td> <td data-bbox="860 546 1259 581">DVD, Satellite, Cable Box, DTV, HD, Skip</td> </tr> </table> <p> <b>If you select Skip, your TV skips this input when you press the TV/VIDEO button.</b></p>	Video 1/2/3/4	VHS, DVD, Receiver, Satellite, Cable Box, 8mm, DTV, LD, Beta, Skip	Video 5/6/7	DVD, Satellite, Cable Box, DTV, HD, Skip				
Video 1/2/3/4	VHS, DVD, Receiver, Satellite, Cable Box, 8mm, DTV, LD, Beta, Skip								
Video 5/6/7	DVD, Satellite, Cable Box, DTV, HD, Skip								
Language	Select to display all on-screen Menus in your language of choice.								
Clock/Timers	<p>Select to set the clock and to program your TV to turn on and off at two scheduled viewing times.</p> <table border="1"> <tr> <td data-bbox="618 789 860 824">Timer 1</td> <td data-bbox="860 789 1259 824">You can use the Timers to program the TV to turn on and off and tune to a specific channel at two scheduled viewing times.</td> </tr> <tr> <td data-bbox="618 824 860 859">Timer 2</td> <td data-bbox="860 824 1259 859"></td> </tr> </table> <p>Timer 1 and Timer 2 are not available to be set until you set the Current Time.</p> <ol style="list-style-type: none"> <li>1 Move the joystick  or  to highlight Timer 1 or Timer 2. To set the timer, move the joystick .</li> <li>2 Move the joystick  or  to highlight one of the following options, then press . <table border="1"> <tr> <td data-bbox="665 1119 860 1189">Program</td> <td data-bbox="860 1119 1259 1189">Select to set the Timer by day, time, duration, and channel.</td> </tr> <tr> <td data-bbox="665 1189 860 1258">Off</td> <td data-bbox="860 1189 1259 1258">Select to turn off the Timer. (Your previous settings are saved.)</td> </tr> </table> </li> <li>3 If you selected Program in step 2, move the joystick  and  to set the day(s), hour, minute, duration, and channel number. Press  or move the joystick  to confirm each setting and move to the next setting. Move the joystick  to go back to the previous setting.</li> <li>4 Press MENU to exit the Menu. An LED on the front panel will light, indicating the timer has been set.</li> </ol>	Timer 1	You can use the Timers to program the TV to turn on and off and tune to a specific channel at two scheduled viewing times.	Timer 2		Program	Select to set the Timer by day, time, duration, and channel.	Off	Select to turn off the Timer. (Your previous settings are saved.)
Timer 1	You can use the Timers to program the TV to turn on and off and tune to a specific channel at two scheduled viewing times.								
Timer 2									
Program	Select to set the Timer by day, time, duration, and channel.								
Off	Select to turn off the Timer. (Your previous settings are saved.)								

 You can also access Flash Focus by pressing the FLASH FOCUS button on the front panel of the TV. For details, see pages 14-15.

Option	Description
Clock/Timers (continued)	<p>Current Time</p> <hr/> <ol style="list-style-type: none"> <li>1 Press  to select Current Time.</li> <li>2 Move the joystick  and  to set the current time (day, hour, and minute). Press  (or move the joystick ) to confirm each setting and move to the next setting. Move the joystick  to go back to the previous setting.</li> <li>3 Press MENU to exit the Menu.</li> </ol>
Flash Focus	<p>Allows you to adjust the convergence automatically. For details, see page 42.</p>
Convergence	<p>Allows you to fine-tune the convergence manually. For details, see page 43.</p>
i.LINK Standby	<p>On</p> <p>Allows the i.LINK signal to pass through to connected i.LINK devices even when the TV is turned off. The front panel i.LINK Standby LED shows orange. The TV uses more standby power than when this option is set to Off.</p>
	<p>Off</p> <p>Does not allow the i.LINK signal to pass through to connected i.LINK devices when the TV is turned off. The front panel i.LINK Standby LED shows red. The TV uses less standby power than when this option is set to On.</p>
Demo	<p>Runs a demonstration of on-screen Menus.</p>



# Other Information

## Overview

This chapter includes the following topics:

<i>Topic</i>	<i>Page</i>
Glossary	108
Contacting Sony	109
Troubleshooting	109
Specifications	115
Optional Accessories	116
Index	117

# Glossary

**analog signal** A signaling method that uses continuous changes in the amplitude or frequency of an electronic transmission to convey information.

**aspect ratio** Refers to the ratio between the width and height of the screen. This TV has a 16:9 (widescreen) aspect ratio, as opposed to a 4:3 aspect ratio.

4:3 aspect ratio



16:9 aspect ratio



**component video**



Component video is sent through three cables: two color shade (chrominance) signals and one brightness (luminance) signal. Component video achieves greater color accuracy than composite video or S VIDEO by splitting chrominance into two separate portions.

**composite video**



Composite video is sent through a single cable. Composite video combines the color shade (chrominance) and brightness (luminance) information into one video signal.

**digital television (DTV)**

A new technology for transmitting and receiving broadcast television signals. DTV provides higher resolution and improved sound quality over analog television.

**National Television System Committee (NTSC)**

A unit of the Federal Communications Commission, Washington, DC, that establishes television standards in the United States, such as NTSC Color, the standard used in this TV.

**RF**

Radio Frequency. That part of the frequency spectrum that is used to transmit TV and radio signals.

**S VIDEO**



S VIDEO requires a single cable, which carries the brightness (luminance) and color (chrominance) signals of the picture separately. S VIDEO provides better resolution than composite video, which carries the signals together.

**VHF/UHF**

VHF (Very High Frequency) is the part of the frequency spectrum from 30 to 300 megahertz. UHF (Ultra High Frequency) is the part of the frequency spectrum from 300 to 3,000 megahertz.

**480i**

Provides 480 lines of resolution. Displays images using interlaced scanning, which first transmits all the odd lines on the TV screen and then the even lines.

**480p**

Provides 480 lines of resolution. Displays images using progressive scanning, which transmits each line from top to bottom.

**720p**

Provides 720 lines of resolution. Displays images using progressive scanning, which transmits each line from top to bottom.

**1080i**

Provides 1080 lines of resolution. Displays images using interlaced scanning, which first transmits all the odd lines on the TV screen and then the even lines. 1080i is one of the formats used by HDTV (High Definition TV).



## Contacting Sony

If, after reading these operating instructions, you have additional questions related to the use of your Sony television, please call our Customer Information Services Center at 1-800-222-SONY (7669) (US residents only) or (416) 499-SONY (7669) (Canadian residents only).

Before calling Sony customer support, please write down the model and serial numbers of your TV. You'll find this information on the front cover of this manual.

## Troubleshooting

If you are having problems with your TV, you can reset all the TV's settings to their original factory default settings, as follows.

 **Notice:** The following procedure resets all custom settings, channel lists, etc., to the factory default settings.

- 1 Turn on the TV.
- 2 Hold down the RESET button on the remote control.
- 3 Press the POWER button on the front panel of the TV.
- 4 Release the RESET button on the remote control.

### Twin View

Problem	Possible Remedies
I cannot get Twin View to work	<ul style="list-style-type: none"><li><input type="checkbox"/> If you are using a cable box to unscramble all channels (as shown on page 22), you cannot use the Twin View feature. This is because the cable box can unscramble only one channel at a time. But if you need the cable box to unscramble only some (usually premium) channels, you can use Twin View for unscrambled channels if you connect both a cable and cable box, as shown on page 21.</li><li><input type="checkbox"/> You can use Twin View to view a signal from a different source that is connected to the TV's A/V jacks (such as a VCR or DVD player) in the second window by pressing the TV/VIDEO button while in Twin View.</li><li><input type="checkbox"/> Sources connected to the CABLE, VIDEO 5, VIDEO 6, and VIDEO 7 inputs, as well as digital sources, display in the left Twin View window, but not the right.</li></ul>
There is no Twin View window, or it is just static	<ul style="list-style-type: none"><li><input type="checkbox"/> Be sure the Twin View window is set to a video input or channel that has a signal airing.</li><li><input type="checkbox"/> You might be tuned to a video input with nothing connected to it. Try cycling through the video inputs by pressing the TV/VIDEO button.</li></ul>
Twin View cannot display anything but TV channels	<ul style="list-style-type: none"><li><input type="checkbox"/> Try cycling through the video inputs by pressing the TV/VIDEO button. Check that the Video Label option is not set to Skip. (See the Setup Menu on page 104.)</li></ul>
Twin View displays the same program in both windows	<ul style="list-style-type: none"><li><input type="checkbox"/> Both Twin View windows might be set to the same channel. Try changing channels in either window.</li></ul>

## Remote Control





<i>Problem</i>	<i>Possible Remedies</i>
Remote control does not operate	<ul style="list-style-type: none"><li><input type="checkbox"/> The batteries could be weak. Replace the batteries.</li><li><input type="checkbox"/> Check the orientation of the batteries.</li><li><input type="checkbox"/> Press the TV FUNCTION button. You may have inadvertently pressed the SAT/CABLE FUNCTION button, which changes the remote control to SAT or CABLE mode.</li><li><input type="checkbox"/> Make sure the TV's power cord is connected securely to the wall outlet.</li><li><input type="checkbox"/> Locate the TV at least 3-4 feet away from fluorescent lights.</li></ul>
Cannot change channels with the remote control	<ul style="list-style-type: none"><li><input type="checkbox"/> If you are using the TV to change channels, first press the TV FUNCTION button.</li><li><input type="checkbox"/> If you are using another device to change channels, be sure you have not inadvertently switched your TV from the channel 3 or 4 setting. Use the Channel Fix option to "fix" the channel based on the hookup you used (see page 98).</li><li><input type="checkbox"/> If you are using another device to change channels, be sure to press the FUNCTION button for that device. For example, if you are using your cable box to change channels, be sure to press the SAT/CABLE FUNCTION button.</li></ul>
Remote control does not operate non-Sony video equipment	<ul style="list-style-type: none"><li><input type="checkbox"/> If you replaced the batteries to the remote recently, the code numbers for the video equipment may need to be reset.</li><li><input type="checkbox"/> There may be more than one code for the equipment that you are attempting to operate.</li><li><input type="checkbox"/> There is a possibility that some non-Sony equipment cannot be operated by your Sony TV remote. You may need to use the equipment's original remote control.</li></ul>

## Channels

<i>Problem</i>	<i>Possible Remedies</i>
Cannot receive upper channels (UHF) when using an antenna	<ul style="list-style-type: none"><li><input type="checkbox"/> Use Auto Program in the Channel Menu to add receivable channels that are not presently in the TV's memory (see page 98).</li></ul>
TV is fixed to one channel	<ul style="list-style-type: none"><li><input type="checkbox"/> Use Auto Program in the Channel Menu to add receivable channels that are not presently in the TV's memory (see page 98).</li><li><input type="checkbox"/> Check your Channel Fix settings (see page 98).</li></ul>
Cannot receive any channels when using cable TV	<ul style="list-style-type: none"><li><input type="checkbox"/> Use Auto Program in the Channel Menu to add receivable channels that are not presently in the TV's memory (see page 98).</li></ul>
Cannot receive or select channels	<ul style="list-style-type: none"><li><input type="checkbox"/> Use Auto Program in the Channel Menu to add receivable TV channels that are not presently in TV memory (see page 98).</li></ul>
Some digital cable channels are not being displayed	<ul style="list-style-type: none"><li><input type="checkbox"/> Certain cable companies have limitations on the broadcast of digital cable channels. Check with your cable company for more information.</li><li><input type="checkbox"/> The digital cable channel may be set to Hide in the Digital Setup Menu (see page 65).</li><li><input type="checkbox"/> Use the Add Digital Channels feature to search for new digital channels (see page 65).</li></ul>

## Memory Stick

<b>Problem</b>	<b>Possible Remedies</b>
Image does not display/ Cannot see all files	<ul style="list-style-type: none"> <li><input type="checkbox"/> Make sure the image file is a JPEG (.jpg, .jpeg) file or an MPEG1 (.mpg, mpeg) file.</li> <li><input type="checkbox"/> Make sure the Memory Stick is inserted properly (see pages 69-70).</li> <li><input type="checkbox"/> Check the Filter option setting (see page 80).</li> <li><input type="checkbox"/> Check the Select Contents setting (see page 80) and ensure that files are either in DCF directories if Digital Camera Folders is selected (see page 80), or in the currently selected folder if Select a Folder is selected (see page 80).</li> <li><input type="checkbox"/> The maximum number of files the Memory Stick Viewer can display is 1,024.</li> <li><input type="checkbox"/> If you are using a Memory Stick with the Memory Select function, try changing the position of the A/B select switch.</li> </ul>
JPEG image displays undesirable motion or flicker in full screen	<ul style="list-style-type: none"> <li><input type="checkbox"/> JPEGs captured using a digital video camera may appear to display motion in full screen. This is a result of the way digital video cameras record still images, and is not a result of a malfunction with the TV.</li> </ul>
Rotation not saved after Memory Stick is ejected or Memory Stick Viewer is closed	<ul style="list-style-type: none"> <li><input type="checkbox"/> The Memory Stick might be locked. Unlock the Memory Stick and try rotating the image again.</li> <li><input type="checkbox"/> The file might not have information (EXIF data) that is usually generated when a digital camera records a photo. In this case, it is not possible to save the rotation.</li> <li><input type="checkbox"/> There might be insufficient space on the Memory Stick to save the rotated file. Try deleting one or more files and rotating the image again.</li> </ul>
Cannot show (or hide) file information in full screen or Slide Show	<ul style="list-style-type: none"> <li><input type="checkbox"/> Set the File/Information option to On or Off (see pages 75 and 78).</li> </ul>
Cannot see menu	<ul style="list-style-type: none"> <li><input type="checkbox"/> Move the joystick <math>\blacktriangle</math> to display the menu again.</li> </ul>
Cannot hear audio while using Memory Stick	<ul style="list-style-type: none"> <li><input type="checkbox"/> Check the TV's volume or Speaker (page 95) settings.</li> <li><input type="checkbox"/> To hear JPEG voice memo, select the Digital Camera Folders option and set the Filter option to Show All.</li> <li><input type="checkbox"/> Check that the Music option is not set to Off (see page 79).</li> </ul>
Not all MP3 files on Memory Stick are included when the Music /Complete List option is selected (page 79)	<ul style="list-style-type: none"> <li><input type="checkbox"/> The maximum number of MP3 files the Memory Stick Viewer can display is 128.</li> <li><input type="checkbox"/> Make sure that the file is named with the file extension (.mp3).</li> </ul>
MPEG1 movie does not play back correctly	<ul style="list-style-type: none"> <li><input type="checkbox"/> Some variations of MPEG1 movies may not be compatible with the Memory Stick Viewer.</li> </ul>
MPEG1 quality is poor when enlarged (page 77)	<ul style="list-style-type: none"> <li><input type="checkbox"/> The quality of the movie when enlarged depends on the resolution of the MPEG1 file. See your camera's instruction manual for details.</li> </ul>
MP3 files on the Memory Stick are not listed	<ul style="list-style-type: none"> <li><input type="checkbox"/> Only MP3 files that are named with the file extension (.mp3) are displayed in the list.</li> </ul>
Music files are playing in wrong order	<ul style="list-style-type: none"> <li><input type="checkbox"/> MP3 files are played in alphabetical order, according to the folder in which they are stored. If you want to change the playlist order, rename your files alphabetically in the order in which you want them to play.</li> </ul>
Cannot see MP3 list to play music	<ul style="list-style-type: none"> <li><input type="checkbox"/> MP3 files on your Memory Stick only can be played as background music during a Slide Show (see page 79).</li> </ul>

<b>Problem</b>	<b>Possible Remedies</b>		
Error message is displayed	<input type="checkbox"/>	No Memory Stick	There is no Memory Stick in the slot.
	<input type="checkbox"/>	Memory Stick Locked	The lock mechanism on the Memory Stick is engaged.
	<input type="checkbox"/>	Memory Stick Error	The Memory Stick in the slot might be damaged; try a different Memory Stick.
	<input type="checkbox"/>	Format Error	The Memory Stick may have been formatted using a PC or other device that is not compatible with cameras.
Error icon is displayed			The file is not a valid MPEG1 or JPEG format.
			The thumbnail is not DCF-compatible.
			The file is a JPEG or an MPEG1, but the thumbnail is unreadable.
			The file is unreadable.

## Audio

<b>Problem</b>	<b>Possible Remedies</b>	
Good picture, no sound	<input type="checkbox"/>	Press <b>MUTING</b> so that Muting disappears from the screen (see page 46).
	<input type="checkbox"/>	Make sure the <b>Speaker</b> option is set to <b>On</b> in the Audio Menu (see page 95).
Cannot gain enough volume when using a cable box	<input type="checkbox"/>	Increase the volume of the cable box using the cable box's remote control. Then press <b>TV FUNCTION</b> and adjust the TV's volume.
Sound seems weak or insufficient	<input type="checkbox"/>	The TV's audio might be set to <b>Auto SAP</b> or <b>Mono</b> , when it might be better set to <b>Stereo</b> . In the Audio Menu (see page 94), set the <b>MTS</b> setting to <b>Stereo</b> . If already set to <b>Stereo</b> , switch to <b>Mono</b> (which may reduce background noise during weak stereo broadcasts).
Cannot raise the volume on external audio speakers	<input type="checkbox"/>	If the <b>Speaker</b> option is set to <b>Off</b> and the <b>Audio Out</b> option is set to <b>Fixed</b> (in order to output the sound to your audio system) use your audio receiver to adjust the sound (see page 94). Or, to use the TV remote control, set the <b>Audio Out</b> option to <b>Variable</b> .
	<input type="checkbox"/>	To turn on the TV speakers, set the <b>Speaker</b> option to <b>On</b> (see page 94).

## Video

<b>Problem</b>	<b>Possible Remedies</b>
No picture (screen not lit), no sound	<ul style="list-style-type: none"> <li><input type="checkbox"/> If your TV does not turn on, and a red light keeps flashing, your TV may need service. Call your local Sony Service Center.</li> <li><input type="checkbox"/> Make sure the power cord is plugged in.</li> <li><input type="checkbox"/> Press the POWER button on the front of the TV.</li> <li><input type="checkbox"/> Press the TV/VIDEO button to cycle through the connected video sources.</li> <li><input type="checkbox"/> Try another channel; it could be station trouble.</li> </ul>
Dark, poor or no picture (screen lit), good sound	<ul style="list-style-type: none"> <li><input type="checkbox"/> Adjust the Picture option in the Video Menu (see page 92).</li> <li><input type="checkbox"/> Adjust the Brightness option in the Video Menu (see page 92).</li> <li><input type="checkbox"/> Check the antenna/cable connections.</li> </ul>
No color	<ul style="list-style-type: none"> <li><input type="checkbox"/> Adjust the Color option in the Video Menu (see page 92).</li> </ul>
Only snow and noise appear on the screen	<ul style="list-style-type: none"> <li><input type="checkbox"/> Check the antenna/cable connections.</li> <li><input type="checkbox"/> Try another channel; it could be station trouble.</li> <li><input type="checkbox"/> Press ANT to change the input mode (see page 46).</li> </ul>
Dotted lines or stripes	<ul style="list-style-type: none"> <li><input type="checkbox"/> Adjust the antenna.</li> <li><input type="checkbox"/> Move the TV away from noise sources such as cars, neon signs, or hair-dryers.</li> </ul>
Double images or ghosts	<ul style="list-style-type: none"> <li><input type="checkbox"/> Using a highly directional outdoor antenna or a cable may solve the problem.</li> </ul>
"Black box" on screen	<ul style="list-style-type: none"> <li><input type="checkbox"/> You have selected a text option in the Setup Menu and no text is available. (See page 103 to reset Setup selections.) To turn off this feature, set the Caption Vision option to Off. If you were trying to select closed captioning, select CC1 instead of Text 1-4.</li> </ul>
Black bands appear at the top and bottom of the screen	<ul style="list-style-type: none"> <li><input type="checkbox"/> Some wide-screen programs are filmed in aspect ratios that are greater than 16:9 (this is especially common with theatrical releases). Your TV will show these programs with black bands at the top and bottom of the screen. For more details, check the documentation that came with your DVD (or contact your program provider).</li> </ul>
Certain programs on DVD or other digital sources display a loss of detail, especially during fast-motion or dark scenes	<ul style="list-style-type: none"> <li><input type="checkbox"/> The compression used by certain digital broadcasts and DVDs may cause your TV's screen to display less detail than usual, or cause artifacts (small blocks or dots, pixelations) to appear on your screen. This is due to your TV's large screen and ability to show very fine detail, and is normal for certain digitally recorded programs. Adjust the reality/clarity in the DRC Palette menu (see page 93) to optimize the picture while viewing these sources.</li> </ul>

## General

<i>Problem</i>	<i>Possible Remedies</i>
How to reset TV to factory settings	<input type="checkbox"/> Turn on the TV. While holding down the RESET button on the remote control, press the POWER button on the TV. (The TV will turn itself off, then back on again.) Release the RESET button.
How to restore Video settings to factory settings	<input type="checkbox"/> Press the RESET button on the remote control while in the Video Menu (see page 92).
How to restore Audio settings to factory settings	<input type="checkbox"/> Press the RESET button on the remote control while in the Audio Menu (see page 94).
Cannot cycle through the other video equipment connected to the TV	<input type="checkbox"/> Be sure the Video Label option is not set to Skip (see page 104).
Cannot operate Menu	<input type="checkbox"/> If a menu option appears in gray, this indicates that the TV is in a state in which the menu option is not available.
Lost password	<input type="checkbox"/> In the password screen (see page 100), enter the following master password: 4357. The master password clears your previous password; it cannot be used to temporarily unblock channels.
LED on front panel is lit	<input type="checkbox"/> The STAND BY LED (see page 15) blinks when the TV is turned on, then shuts off when the picture is displayed. If the LED blinks continuously, this may indicate the TV needs service. <input type="checkbox"/> The TIMER LED (see page 15) indicates that the timer is set. When the timer is set, this LED will remain lit even when the TV is turned off. <input type="checkbox"/> The i.LINK STANDBY LED blinks when the signal from an i.LINK device is being shown.
The signal from a selected i.LINK device is not being displayed	<input type="checkbox"/> If you have several i.LINK devices connected and operating at once, the TV may not be able to display the signal from the selected device. Turn the other i.LINK devices off, and reselect the desired i.LINK device.

# Specifications

Projection System	3 picture tubes, 3 lenses, horizontal in-line system	
Picture Tube	7-inch high-brightness monochrome tubes (6.3 raster size), with optical coupling and liquid cooling system	
Projection Lenses	High performance, large diameter hybrid lens F1.1	
Antenna	75 ohm external terminal for VHF/UHF	
Television System	NTSC, American TV Standard	
Channel Coverage	VHF	2-13
	UHF	14-69
	DTV	1-999
	CATV	1-125
Power Requirements	120V, 60 Hz	
Inputs/Outputs		
DVI-HDTV	1 terminal, 3.3V T.M.D.S., 50 ohms The DVI-HDTV input terminal is compliant with the EIA-861 standard and is not intended for use with personal computers.	
Video (IN)	4 total (1 on front panel)	1 Vp-p, 75 ohms unbalanced, sync negative
S Video (IN)	3 total (1 on front panel)	Y: 1 Vp-p, 75 ohms unbalanced, sync negative C: 0.286 Vp-p (Burst signal), 75 ohms
Audio (IN)	7 total (1 on front panel)	500 mVrms (100% modulation) Impedance: 47 kilohm
Component Video Input	2 (Y, P <sub>B</sub> , P <sub>R</sub> )	Y: 1.0 Vp-p, 75 ohms unbalanced, sync negative; P <sub>B</sub> : 0.7 Vp-p, 75 ohms P <sub>R</sub> : 0.7 Vp-p, 75 ohms
Digital Audio Optical Output PCM/Dolby Digital	1	Optical Rectangular (1)
CONTROLS (IN/OUT)		
i.LINK	3 total (1 on front panel)	4-pin S400 i.LINK terminal
Variable/Fixed Audio (OUT)	1	More than 408 mVrms at the maximum volume setting (Variable) More than 408 mVrms (Fixed) Impedance (output): 2 kilohms
Supplied Accessories		
	Remote Control	RM-Y192
	AA (R6) Batteries	2 supplied for remote control
Screen Size (measured diagonally)		
	KDP-51WS550	51 inches
	KDP-57WS550	57 inches
	KDP-65WS550	65 inches
Speaker Output	20W x 2	
Dimensions (W x H x D)		
	KDP-51WS550	1194 x 1350 x 650 mm (47 x 53 1/8 x 25 5/8 in)
	KDP-57WS550	1326 x 1377 x 690 mm (52 1/4 x 54 3/16 x 27 1/8 in)
	KDP-65WS550	1542 x 1507 x 735 (60 3/4 x 59 1/4 x 28 15/16 in)
Mass		
	KDP-51WS550	79.3 Kg (174.5 lbs)
	KDP-57WS550	87.0 Kg (191.5 lbs)
	KDP-65WS550	139.5 Kg (307 lbs)
Power Consumption		
	In Use	295 W
	In Standby	Under 1 W
	In i.LINK Standby	Under 17 W

Design and specifications are subject to change without notice.

## ***Optional Accessories***

- ❑ A/V Cable (VMC-810/820/830 HG)
- ❑ Audio Cable (RKC-515HG)
- ❑ Component Video Cable (VMC-10/30 HG)
- ❑ Control S Cable (RK-G69HG)
- ❑ i.LINK cables: VMC-IL4415 (4-pin to 4-pin, 1.5 meters); VMC-IL4435 (4-pin to 4-pin, 3.5 meters)



# Index

0-9 buttons 47, 54, 58  
16:9 aspect ratio 56  
4:3 aspect ratio 56  
4:3 Default settings 97

## A

Add Digital Channels 65  
Advanced Video 93  
Alternate Audio 64  
Alternate Video 64  
ANT button 46, 54  
antenna, connecting 19  
Audio Menu 91, 94  
Audio Out 95  
audio receiver, connecting 38  
Auto Program (channel setup) 41, 98  
Auto SAP, MTS setting 94

## B

balance, adjusting 94  
bass, adjusting 94  
batteries, inserting in remote 45  
BBE 94  
bilingual audio 94  
blocking programs. *See ratings.*  
brightness, adjusting 92

## C

cable  
connecting 19  
with VCR, connecting 24  
cable box  
connecting with VCR 26  
Twin View issues 57  
using with TV remote control 52  
CABLE jack, described 17  
Caption Vision 103  
Caption Vision menu, for digital channels 65

carrying the TV 12  
CATV. *See cable*  
CH buttons 15, 47  
changing picture size, in Twin View 59  
Channel Menu 91, 98  
Channel Show/Hide 65  
Channel Skip/Add 98  
channels, creating labels 99  
CineMotion 10, 46, 93  
ClearEdge VM 10, 92  
clearing, Favorite Channels 60  
closed caption modes 91, 103  
CODE SET button 46  
color, adjusting 92  
CONTROL S 40  
CONTROL S IN/OUT jacks, described 17  
Convergence 15, 105  
adjusting automatically 42  
adjusting manually 43  
convergence 105  
Cool, Color Temperature 92

## D

Demo, Menus 105  
DIGITAL AUDIO OPTICAL jack 17  
Digital Caption Setup 65  
Digital Caption Setup menu 66  
digital channels, adding 98  
Digital Reality Creation 9  
Digital Setup menu 65  
Digital Signal Strength 65  
digital subchannels 64  
Digital Visual Interface (DVI) 10, 17  
DISC MENU button 48, 52  
DISPLAY button 47, 54  
DRC Mode 93  
DRC MODE button 46

DRC Palette 93  
DRC PALETTE button 47  
DRC. *See Digital Reality Creation.*  
DVD player  
connecting 34, 36  
using with TV remote control 52  
DVI. *See Digital Visual Interface.*  
DVI-HDTV 17, 115

## E

Effect button 48  
ENTER button 47, 54, 58  
error messages, Memory Stick 112  
EXIT button 47

## F

Fast-forward button 48  
Favorite Channels  
clearing 60  
in Channel Menu 98  
using 60  
FAVORITES button 46  
features 9  
Fixed audio setting 95  
Flash Focus 42, 105  
FLASH FOCUS button 15  
FREEZE button 47, 61  
Freeze, using 61  
Full Mode 56  
Full mode, setting 96

## G

GUIDE button 47, 63  
Guide menu 64

## H

HD Detailer 10  
HD/DVD IN (1080i/720p/480p/480i) jacks, described

17  
hue, adjusting 92

## I

i.LINK 10, 13, 83–89  
i.LINK button 46  
I.LINK jack, described 17  
i.LINK Standby 15, 105  
i.LINK/AV1-3/DVD slide  
switch 48  
INDEX button 46, 55  
Infrared Receiver 15  
interlaced 9, 46, 93, 108

## J

joystick 46  
JUMP button 47, 54

## L

label, channels 99  
Language, setting 104

## M

MDP, using with TV remote  
control 52  
Memory Stick  
button 47  
Duo 70  
features 67  
Index 72  
indicator (LED) 15  
inserting 69  
insertion slot 15  
panning photos 76  
photo options 75  
playing movies 77  
precautions 82  
removing 71  
rotating photos 76  
slide show options 79  
troubleshooting 111  
Viewer, described 10  
viewing photos 74  
zooming photos 76

MENU button 46, 48, 54, 60,  
91

## Menus

Audio 91, 94  
Channel 91, 98

Parent 91, 100  
Setup 91, 103  
Video 91, 92, 96  
MONITOR OUT 17  
Mono, MTS setting 94  
Movie mode 92  
MTS 94  
MTS/SAP button 48  
MUTING button 46, 54

## N

Neutral, Color Temperature  
92  
Normal mode 56, 96

## O

off, turning off the TV 15  
on, turning on the TV 15

## P

Parent Menu 91, 100  
parental control, described 10  
password, changing 100  
Pause button 48  
PIC MODE button 47  
picture contrast, adjusting 92  
Picture in Picture. *See Twin  
View.*  
Play button 48  
POWER button 15  
powering on/off, the TV 15  
presetting channels 98  
Pro (Video) mode 92  
problems, troubleshooting  
109–114  
Program Guide 63  
Program Options menu 64  
progressive 9, 46, 93, 108

## R

ratings, setting 100–102  
ratings, viewing blocked  
programs 101, 102  
Record buttons 48  
remote control  
inserting batteries 45  
programming 49–50  
removing, Favorite Channels

60

RESET button 46, 93  
resetting, Audio options 94  
Rewind button 48

## S

S VIDEO jack, described 13,  
17  
SAT/CABLE  
FUNCTION button 47  
POWER button 47  
satellite receiver, using with  
TV remote control 51  
Scrolling Index, using 55  
SELECT button 48  
Setup Menu 91, 103  
sharpness, adjusting 92  
Simulated, Effect 94  
sizing, picture in Twin View  
59  
SLEEP button 46  
speakers  
turning on/off 95  
using external speakers 95  
specifications 115  
STAND BY indicator 15, 114  
Standard mode 92  
Steady Sound  
described 10  
setting 94  
Stereo, MTS setting 94  
Stop button 48  
surround sound 94  
SYSTEM OFF button 48

## T

Timer 104  
TIMER indicator 15, 114  
timers, setting 104  
transport buttons 48  
treble, adjusting 94  
troubleshooting 109–114  
TruSurround 94  
TruSurround, Effect 94  
turning on/off the TV 15  
TV FUNCTION button 47, 54  
TV POWER button 47, 54  
TV/VCR button 48

TV/VIDEO button 15, 46, 54

Twin View

button 47

described 10

using 57–59

## V

Variable audio setting 95

VCR

using with TV remote  
control 51

with cable box, connecting  
26

with cable, connecting 24

with satellite receiver,  
connecting 32

VCR/DVD button 48

Vertical Center, adjusting 97

VHF/UHF jack, described 17

VIDEO (L/R)/AUDIO jacks,  
described 17

Video Menu 91, 92

Video modes, selecting 92

Vivid mode 92

VOL buttons 15, 46, 54

## W

Warm, Color Temperature 92

Wide Mode 56, 96

WIDE MODE button 46, 56

Wide Screen, described 9

Wide Zoom mode 56, 96

## Z

zoom feature, with Twin  
View 59

Zoom Mode 56, 96



# LIMITED WARRANTY

This warranty is applicable to U.S. residents only. If you are a Canadian resident, see the separately enclosed warranty for your product.

Sony Electronics Inc. ("Sony") warrants this Product (including any accessories) against defects in material or workmanship, subject to any conditions set forth as follows:

1. **LABOR:** For a period of 90 days from the date of purchase, if this Product is determined to be defective, Sony will repair or replace the Product, at its option, at no charge, or pay the labor charges to any Sony authorized service facility. After the Warranty Period, you must pay for all labor charges.
2. **PARTS:** In addition, Sony will supply, at no charge, new or rebuilt replacements in exchange for defective parts for a period of one (1) year (color picture tube- two (2) years). After 90 days from the date of purchase, labor for removal and installation is available from Sony authorized service facilities or a Sony Service Center at your expense.
3. **ACCESSORIES:** Parts and labor for all accessories are for one (1) year.

In-home diagnostic warranty service is provided during the initial 90 day period for 19" (measured diagonally), or larger screen size through a Sony authorized service facility.

To obtain warranty service, you must take the Product, or deliver the Product freight prepaid, in either its original packaging or packaging affording an equal degree of protection, to any authorized Sony service facility.

This warranty does not cover customer instruction, installation, set up adjustments or signal reception problems.

This warranty does not cover cosmetic damage or damage due to acts of God, accident, misuse, abuse, negligence, commercial use, or modification of, or to any part of the Product, including the antenna. This warranty does not cover damage due to improper operation or maintenance, connection to improper voltage supply, or attempted repair by anyone other than facility authorized by Sony to service the Product. This warranty does not cover Products sold AS IS or WITH ALL FAULTS, or consumables (such as fuses or batteries). This warranty is valid only in the United States.

Proof of purchase in the form of a bill of sale or receipted invoice which is evidence that the unit is within the Warranty period must be presented to obtain warranty service.

This warranty is invalid if the factory applied serial number has been altered or removed from the Product.

---

REPAIR OR REPLACEMENT AS PROVIDED UNDER THIS WARRANTY IS THE EXCLUSIVE REMEDY OF THE CONSUMER. SONY SHALL NOT BE LIABLE FOR ANY INCIDENTAL OR CONSEQUENTIAL DAMAGES FOR BREACH OF ANY EXPRESS OR IMPLIED WARRANTY ON THIS PRODUCT, EXCEPT TO THE EXTENT PROHIBITED BY APPLICABLE LAW, ANY IMPLIED WARRANTY OF MERCHANTABILITY OR FITNESS FOR A PARTICULAR PURPOSE ON THIS PRODUCT IS LIMITED IN DURATION TO THE DURATION OF THIS WARRANTY.

---

Some states do not allow the exclusion or limitation of incidental or consequential damages, or allows limitations on how long an implied warranty lasts, so the above limitations or exclusions may not apply to you. In addition, if you enter into a service contract with the Sony Partnership within 90 days of the date of sale, the limitation on how long an implied warranty lasts does not apply to you. This warranty gives you specific legal rights, and you may have other rights which vary from state to state.

For your convenience, Sony Electronics Inc. has established telephone numbers for frequently asked questions:

To locate the servicer or dealer nearest you, or for service assistance or resolution of a service problem, or for product information or operation, call:

**Sony Customer Information Service Center**

1-(800)-222-7669

Or visit the Sony Web Site:

[www.sony.com](http://www.sony.com)

For an accessory or part not available from your authorized dealer, call:

1-(800)-488-SONY(7669)