

Understanding Horizontal Stages Of Multi-Frequency CRT Video Displays

Fifth In A Series Of Articles Covering Multi-Frequency Horizontal Stage Analyzing

By **Glen Kropuenske**

Application Engineer
Sencore Electronics

Computer monitors and other multi-frequency displays change operating modes for higher display resolution. Changing modes increases or decreases the operating frequency of the horizontal output stage(s). Keeping the CRT high voltage and yoke current constant with horizontal frequency changes requires altering the operation of the horizontal output stage. This article looks at how the horizontal frequency impacts the high voltage and deflection produced by horizontal output stages. It further examines how multi-frequency monitors alter the operation of the horizontal output stage to regulate the high voltage and/or deflection current.

How Frequency Affects High Voltage/Deflection In The Horizontal Output Stage

To understand how energy to the flyback transformer or coil changes with

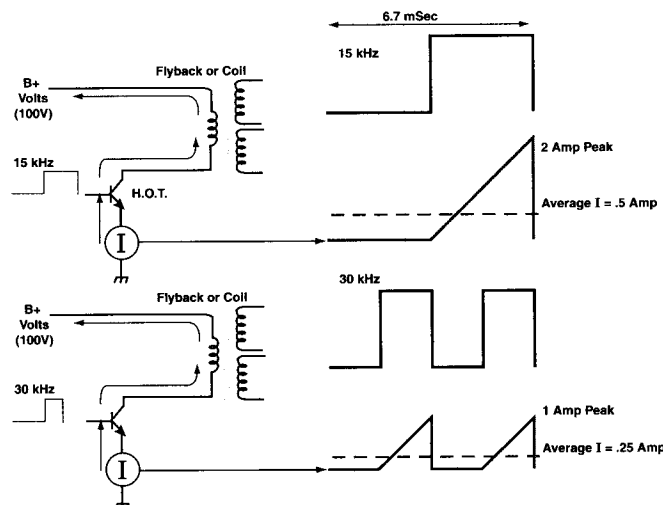

Fig. 1: Increasing the horizontal frequency reduces the average flyback or coil current and input energy to the horizontal output stage.

frequency, consider the conduction time of the H.O.T. during the horizontal cycle. Recall that this is the time during the horizontal cycle that all the energy to produce high voltage and/or deflection is input to the output stage (see Fig. 1). When the H.O.T. is switched on, the B+ supply produces a rising current in the inductive transformer or coil winding. The rising current builds a magnetic field in the coil. The intensity of the magnetic field depends on the current buildup. The input energy (magnetic field intensity) produces induced voltage and alternating currents in the horizontal output stage during the remainder of the cycle. The level of induced voltage and alternating currents determine the high voltage and yoke deflection.

For ease in comparing input energy at different operating frequencies, consider the rise in current in the flyback or coil to be linear. In normal operations, the current rise is not perfectly linear due to the resistance and inherent capacity of the flyback or coil. For example, with a frequency of 15 kHz, a B+ supply voltage of 100 volts may produce a flyback primary current reaching a 2 amp peak (see Fig. 1). The H.O.T. normally conducts approximately 1/2 of the horizontal cycle. With a linear current increase and 50% conduction time, the average current in the coil calculates to 0.5 amps (50 W). A portion of this energy is transferred to the flyback secondaries and retrace capacitor C_t to produce high voltage and deflection current.

With a drive frequency of 30 kHz, the conduction time of the H.O.T. each cycle is cut in half. The reduced conduction time reduces the current buildup to a 1 amp peak with the same applied B+ voltage and inductor. In comparison to 15 kHz, the H.O.T. completes two conduction cycles, but the average current calculates to approximately 0.25 amps or an input power of 25 watts. This is determined by averaging the conduction current values and dividing the result by two for the 50% conduction time.

Because a linear current example was used, a linear relationship between frequency and input energy results. But keep in mind the current increase is not perfectly linear and therefore the relationship between frequency and input energy is not linear. However, from the example, it should be clear that an increase in the horizontal drive frequency to the horizontal output stage reduces the average current or input power to the flyback or coil. Oppositely, a decrease in the horizontal drive frequency results in an increase in the average current to the flyback or coil, increasing the input power.

It is the input energy to the flyback primary or coil that is available to produce induced voltage and alternating current in the horizontal output stage the remainder of the cycle. When the H.O.T. is switched open, the magnetic field in the flyback or coil collapses. The collapsing field produces induced voltage and charging current to the retrace or timing capacitor (see Fig. 2). The intensity of the magnetic field determines how much voltage and charging current is produced. If the intensity of the magnetic field is produced with an operating frequency of 15 kHz and 0.5 amp average current as in the previous example, the voltage rises to some voltage level. If the intensity of the magnetic field reflects the 30 kHz frequency and 0.25 amp average current, much less induced voltage and charging current results from the collapsing magnetic field, reducing the voltage or flyback pulse amplitude.

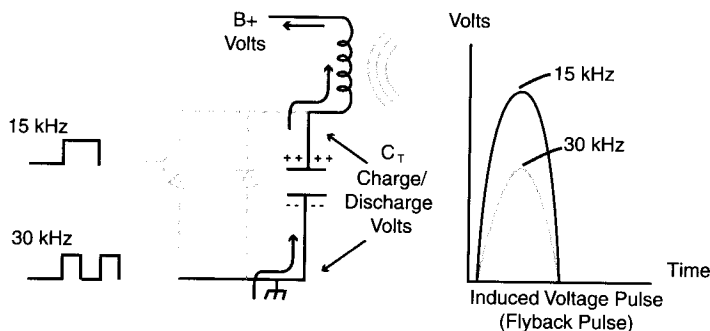

Fig. 2: The intensity of the flyback or coil's magnetic field determines the charging current to C_T and amplitude of the induced voltage pulse.

It stands to reason that if the intensity or strength of the collapsing magnetic field is about half as strong, the level of induced voltage into the flyback secondary windings is cut in half, reducing the high voltage. Also recall that C_T sources current for the deflection yoke in a single or split damper horizontal output stage. In these configurations, the voltage applied to the yoke and resulting yoke current would be reduced.

Horizontal Output Stage Changes To Regulate HV Or Deflection

For a horizontal output stage to maintain the same level of high voltage or deflection at a new operating frequency, the input energy must be sufficient and the flyback voltage pulse must reach approximately the same amplitude. A desired amplitude reflects sufficient input energy and induced voltage and charging current to C_T from the collapsing magnetic field of the coil or transformer. There are four ways to increase or decrease the induced voltage and charge to C_T at a new operating frequency. They include:

1. Increasing or decreasing the B+ supply voltage.
2. Increasing or decreasing the conduction time of the H.O.T.
3. Increasing or decreasing retrace capacitor C_T value.
4. Increasing or decreasing inductor value.

The first two methods, changing the B+ supply or conduction time of the H.O.T., are methods that affect the level of input current in the coil or transformer. If the average input current in the coil or transformer winding is increased or decreased, the strength of the magnetic field is strengthened or reduced.

The level of input current in the coil or transformer of a horizontal output stage is directly affected by the B+ supply voltage. A higher B+ voltage causes a faster rising current and higher current peak. A lower B+ voltage causes a slower rising current and reduced current peak. Therefore, the amplitude of the induced voltage to C_T and resulting high voltage and deflection is directly determined by the input B+ voltage. To keep the high voltage and deflection the same at a higher horizontal output stage operating frequency, the B+ voltage can be increased as needed.

The level of input current to the coil or transformer of a horizontal output stage depends on how long the

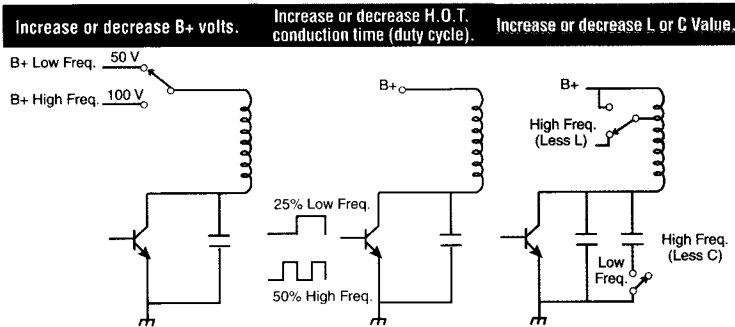

Fig. 3: Methods of altering the horizontal output stage to keep the high voltage and deflection constant at new operating frequencies or modes.

horizontal output transistor is permitted to conduct each horizontal cycle. If the H.O.T. conducts 40% of the time, the current rises to some peak. If the H.O.T. conduction time increases to 60%, the current rises to a much higher peak. The average current and input energy to the transformer or coil increases, resulting in a stronger magnetic field and larger induced or flyback voltage pulse. The high voltage and deflection can be increased or decreased by varying the H.O.T. conduction time. For example, at a higher operating frequency, the duty cycle can be widened to keep the high voltage and deflection the same.

The amplitude of the induced or flyback voltage pulse to C_t can be increased or decreased by changing the value of the inductor or the retrace capacitor.

Decreasing the inductance value results in a faster rising current during the conduction of the H.O.T. and increased resonant frequency during the first and second parts of retrace. The result is a faster expanding and collapsing magnetic field and higher induced voltages to transformer secondaries and C_t . Increasing the inductance slows the rise in energizing current and the collapsing magnetic field resulting in a reduced voltage pulse. In this manner, the inductance value change increases or decreases high voltage and/or deflection.

Increasing or decreasing the retrace capacitor value changes the amplitude of the induced flyback voltage in a similar manner. A decrease in the C_t value raises the resonant frequency, resulting in a faster collapsing magnetic field and higher induced voltage during the first part of retrace. An increase in the C_t value reduces the rate of the collapsing magnetic field, lowering the induced voltage. The value change increases or decreases high voltage and/or deflection accordingly. Decreasing the inductor or C_t value can offset for increases in the horizontal output stage operating frequency to produce nearly the same high voltage and deflection.

Practical Examples Of High Voltage Or Deflection B+ Supply Regulators

Multi-frequency video display monitors use one of these methods or a combination of them to compensate the horizontal output stage(s) as operating frequencies or resolution modes change.

Inductor Value Switching – Inductor value switching is typically combined with capacitor switching in the horizontal output stage for mode or frequency changes. An example of an inductor or transformer value change in the horizontal output stage is shown in Fig. 4. B+ voltage is applied to the flyback either to pin 3 or pin 8 depending on the condition of the contacts of relay (RL458). If Q453 is switched on, the relay coil is energized and the B+ voltage is applied to pin 8 through the closed relay contacts. This reduces the number or flyback primary turns and the value of the primary winding inductance. The relay is energized in this monitor when switching from an operating mode for CGA at 15.7 kHz to EGA mode at 21.8 kHz.

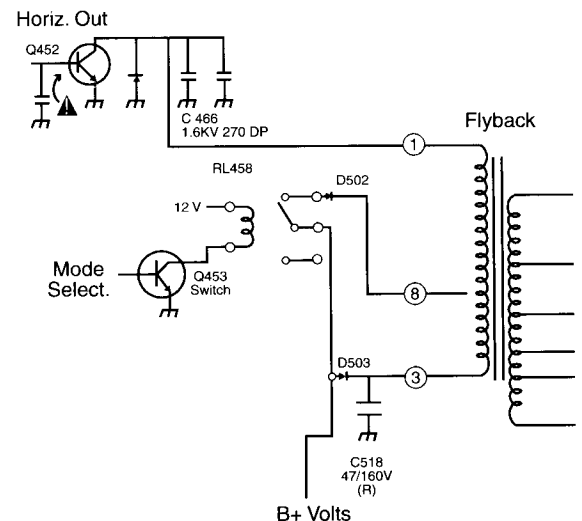

Fig. 4: Example of inductor switching in horizontal output stage for a frequency or mode change.

Capacitor Value Switching Example – Capacitor switching in the horizontal output stage is common among video display monitors designed to operate at several specific horizontal scan frequencies or modes. Figure 5 shows an example of a multi-mode monitor with capacitor switching. Capacitors are switched into the horizontal output stage by relay contacts of relay RL451 and RL452. These relay contacts are shown as switches in Fig. 5. The addition of capacitance values of parallel capacitors C466, C467, C464, and C465 determine the C_t value of the horizontal output stage.

When the monitor is operating at a CGA frequency or mode of 15.7 kHz, relay RL452 is energized and the contacts are closed, placing C465 into the circuit. Capacitor C465 has a relatively large value 7800 pF compared to the other capacitor values. The Ct value is increased, lowering the induced voltage pulse with the same applied B+ voltage to the output stage. The added Ct value also widens the time of the flyback voltage pulse to that required for proper retrace and blanking for CGA operation.

When the monitor increases in operating frequency to EGA, relay RL452 is switched open, removing capacitor C465 from the output stage. Relay RL451 is energized to switch C464 into the horizontal output stage. The capacitance value of C464 is 2700 pF, which decreases the total Ct value compared to CGA operation. This narrows the flyback pulse time and keeps the amplitude of the flyback pulse nearly the same as it was for CGA operation to maintain the needed high voltage and deflection. A narrow flyback pulse time is also needed for faster blanking or retrace during EGA operation. Capacitor C464 may be switched open, permitting yet a higher operating mode for the horizontal output stage.

Figure 6 shows an example of series capacitor switching using a MOSFET transistor (Q509). When the transistor is switched on, capacitor C513 is shunted effectively removing it from the output stage. The Ct value of the horizontal output stage is equal to C512 or .0068 uF. When the transistor is switched open, capacitor C513 is added to the horizontal output stage, reducing the Ct value. When operating at a low frequency mode, the transistor is switched on to establish the proper high voltage, deflection, and pulse time. When switching to a higher frequency mode of operation, voltage to the gate of transistor Q509 is switched to near zero volts, effectively adding capacitor C513 to the output stage.

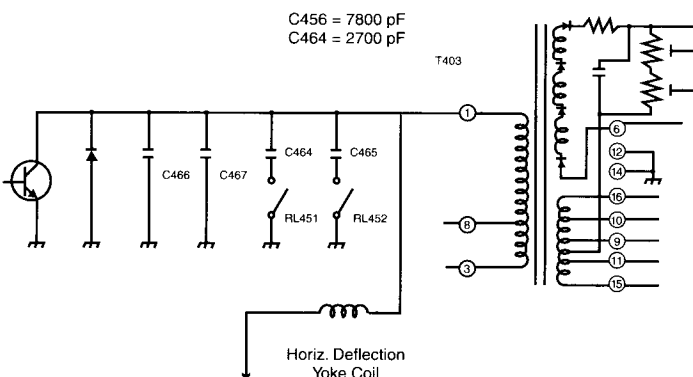

Fig. 5: Switching capacitors in parallel increase the Ct total value to reduce the flyback pulse amplitude at low frequency modes.

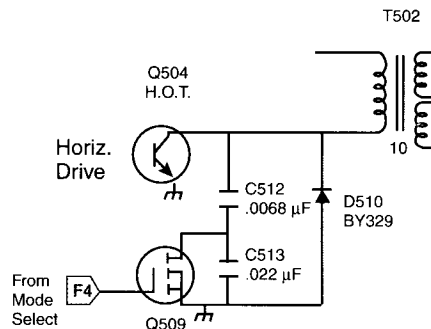

Fig. 6: Capacitor switching in series changes the timing of the output stage for proper high voltage and/or deflection at a different frequency.

H.V. Or Deflection B+ Regulator – Varying the B+ voltage to the horizontal output stage is a common method used by multi-frequency video monitors to maintain normal high voltage and/or deflection as horizontal frequencies or modes change. The B+ can be varied as needed with either a linear pass regulator or a switching type regulator. The regulator is placed in the monitor circuitry between the regulated B+ output of the monitor's main power supply and the B+ input to the flyback or coil of the horizontal output stage. The regulator is commonly called the high voltage or deflection regulator.

A linear regulator is shown in Fig. 7. The regulated 80 volts from the main power supply is applied to the input of IC501, the linear series pass regulator IC. The regulated output voltage from IC501 is applied to pin 3 of the flyback transformer through R510. IC501 is shunted by resistor R507 to produce some start voltage and current to the output stage and reduce the power dissipation of IC501 during normal operation.

Control, or the voltage output of the linear regulator IC501 is determined by the conduction of Q502. Voltage pulses induced into the flyback secondary winding at pin 15 are rectified and filtered into a DC voltage. The voltage provides feedback to the regulator as to the amount of magnetic energy (induced voltage) in the flyback and resulting high voltage. The voltage is divided down by resistors R511, VR501, and R512 and applied to the base of Q502. VR501 adjusts the conduction of Q502 and the output B+ voltage to flyback pin 3 to establish normal high voltage and deflection.

During normal operation, the B+ voltage is varied only slightly to regulate the high voltage and deflection. For example, CRT current from the flyback varies as scene brightness levels vary. When the operating frequency of the horizontal output stage changes, the high voltage

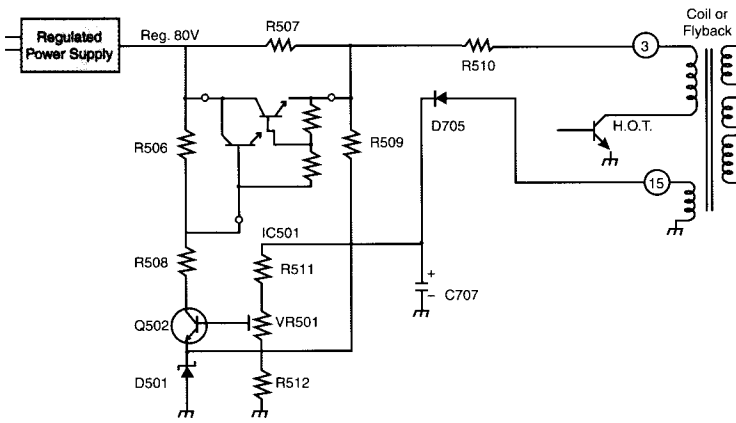

Fig. 7: Example of a linear high voltage/deflection B+ regulator in a multi-mode computer display monitor.

and/or deflection increases or decreases. The regulator automatically increases or decreases the B+ voltage to the output stage to keep the high voltage and/or deflection the same. For example, if the frequency of the horizontal output stage is increased, the input energy to the flyback decreases, lowering the high voltage and feedback voltage to Q502. Q502 conducts less, increasing the conduction of the transistors within IC501. The output B+ voltage increases until the feedback voltage returns to near normal returning the high voltage and/or deflection to near normal.

A linear B+ regulator has the disadvantage of added power dissipation, especially at low horizontal output stage frequency modes. A switching type regulator can provide a wider range of output B+ voltage with less power dissipation. The most common switching high voltage and/or deflection regulator is shown in Fig. 8. The switching regulator commonly uses a power MOSFET (Q5G6). This switching regulator is commonly called a "buck converter."

The switching MOSFET has the regulated output voltage from the monitor's main switch mode power supply input to the drain lead. The gate lead has an on/off drive signal applied to it. The drive signal originates from a separate output from the horizontal oscillator so it is locked to the horizontal frequency. The drive signal is varied in duty cycle (pulse width modulated) by the regulation control circuits, amplified, and coupled to the gate lead.

The DC output voltage from the regulator to the horizontal output stage is produced across C583. As Q5G6 is switched on by the gate drive signal, current flows from the B+ supply, producing current to the output stage and energy stored in L5G1 and L5G2's

magnetic field. When the MOSFET switches open, current ceases and the magnetic fields of the coils collapse causing current to flow through D5G7 charging capacitor C583. A DC voltage is developed across C583 relative to the conduction time of Q5G6. The duty cycle of the gate drive to the MOSFET switching transistor determines the B+ voltage to the output stage and resulting high voltage.

The regulation control circuit shapes the horizontal signal into the proper duty cycle. The duty cycle of the gate drive is determined by the regulation control circuits with feedback voltage derived from the flyback transformer. Flyback voltage pulses are rectified and filtered into a DC feedback voltage. The feedback voltage is compared to a reference voltage with a comparator inside the regulation control circuits. The comparator alters the trigger level of a ramp generator which is also part of the regulation control circuits to develop a shorter or longer duty cycle for the drive signal.

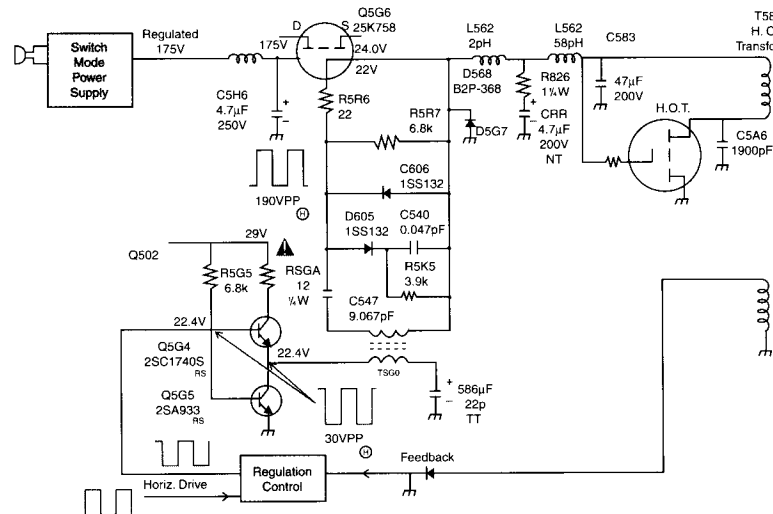

Fig. 8: Example of a switching type high voltage/deflection regulator in a multiscan computer display monitor.

The switching B+ regulator provides a tightly regulated high voltage to the CRT during CRT brightness changes. It further changes the B+ voltage as needed to keep the high voltage or deflection the same as different modes and horizontal operating frequencies are selected. As higher resolution, higher frequency modes are selected, the level of high voltage and/or deflection decreases. The regulation control circuit senses the drop in feedback voltage and increases the duty cycle and B+ voltage to the output stage. The increased B+ voltage returns the high voltage and/or deflection to their normal levels. **SN**