

# Technics

Digital Audio Tape Deck

## SV-DA10

### OPERATING INSTRUCTIONS

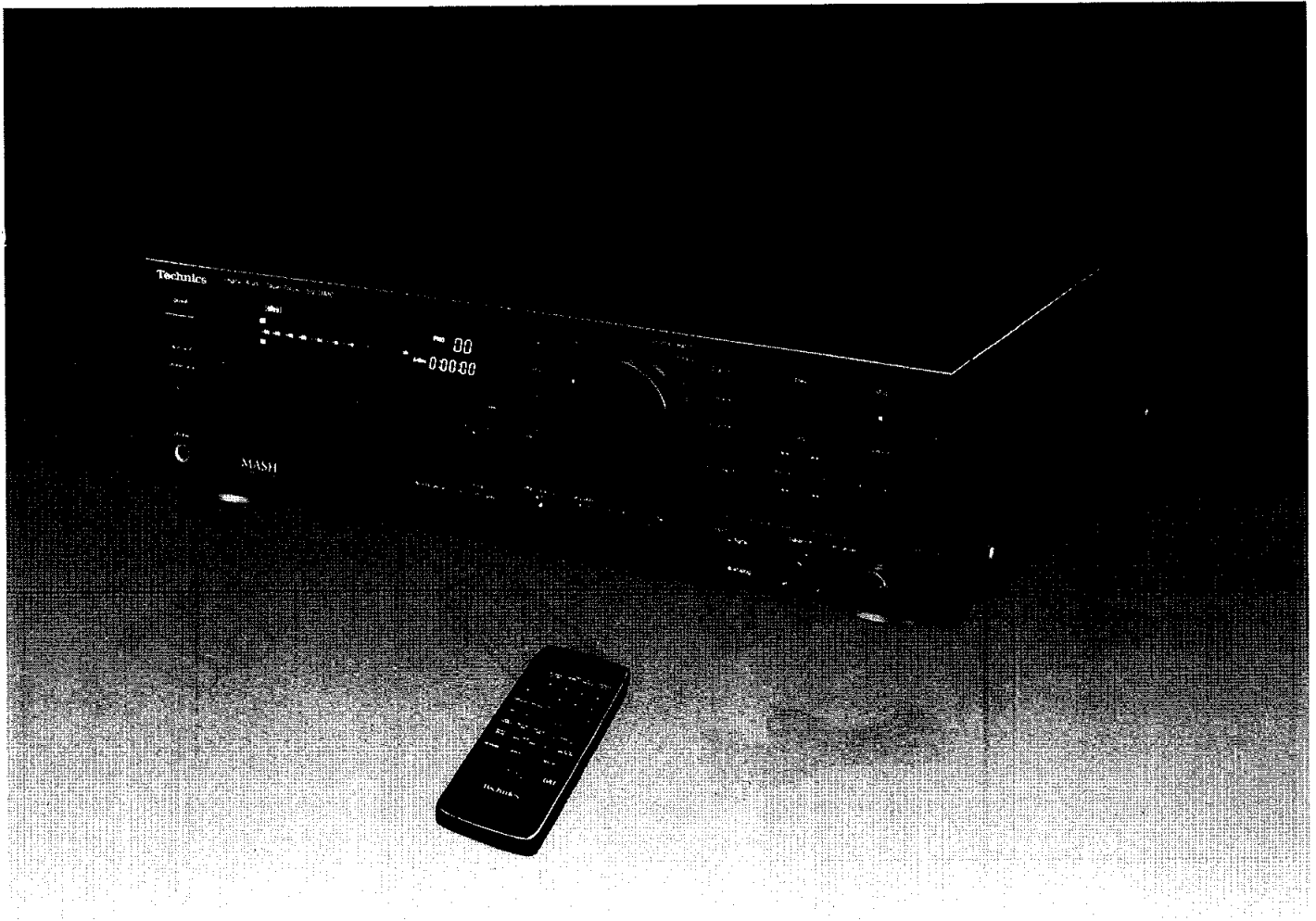

These instructions also apply to units of different colour.

**Notes:**

- Specifications differ according to the area code.
- The "EB" area code, for example, indicates United Kingdom specifications.
- The "EB" indication is shown on the packing case and serial number tag.

## Dear Stereo Fan

We want to thank you for selecting this product and to welcome you to the growing family of satisfied Technics product owners around the world. We feel certain you will get maximum enjoyment

from this new addition to your home. Please read these operating instructions carefully, and be sure to keep them handy for convenient reference.

# Contents

Accessories .....	2	Recording .....	24
For United Kingdom .....	2	Indexing .....	30
Suggestions for Safety .....	3	Timer Recording/Playback .....	36
Installation .....	4	Operation Notes .....	37
Connections .....	5	Maintenance .....	38
Remote Control Transmitter .....	6	About DAT Cassette Tape .....	39
Location of Controls .....	7	Troubleshooting Guide .....	40
Basic Operations for Recording and Playback .....	12	Technical Information 1 .....	41
Playback .....	16	Technical Information 2 .....	43
Before Recording .....	22	Technical Specifications .....	Back cover

# Accessories

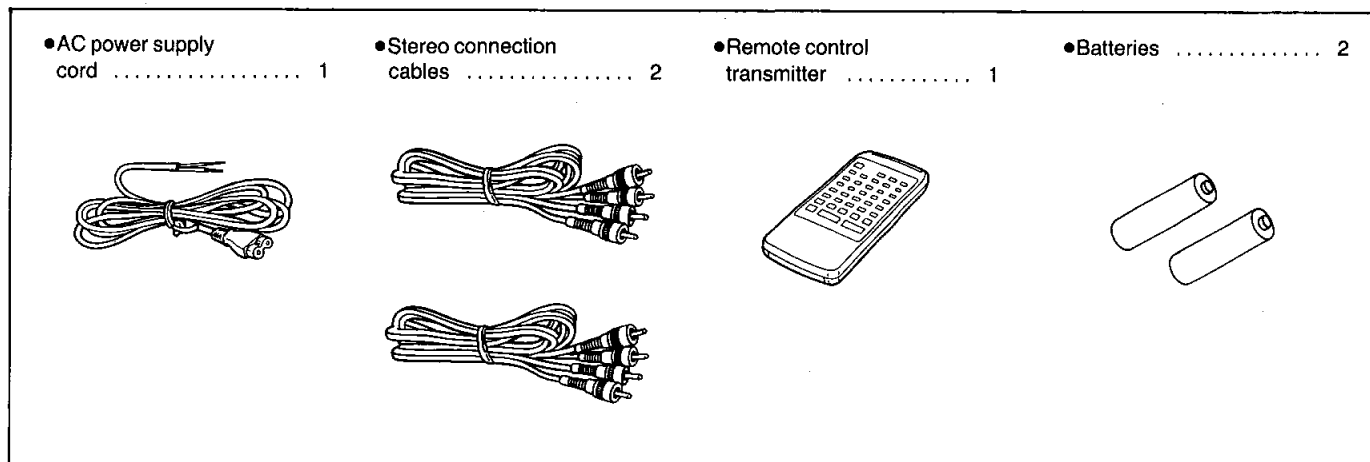

# For United Kingdom

(“EB” area code model only)

The “EB” indication is shown on the serial number tag.

### Important

THE WIRES IN THIS MAINS LEAD ARE COLOURED IN ACCORDANCE WITH THE FOLLOWING CODE.

BLUE: NEUTRAL

BROWN: LIVE

As the colours of the wires in the mains lead of this apparatus may not correspond with the coloured markings identifying the terminals in your plug proceed as follows. The wire which is coloured BLUE must be connected to the terminal which is marked with the letter N or coloured BLACK.

The wire which is coloured BROWN must be connected to the terminal which is marked with the letter L or coloured RED.

Under no circumstances must either of the above wires be connected to the earth terminal of a three pin plug.

This apparatus was produced to BS 800.

# Suggestions for Safety

## ■ Use a standard AC wall outlet

1. **Use from an AC power source of high voltage, such as for an air conditioner, is very dangerous.**

There is the possibility that a fire might be caused by making such a connection.

2. **A DC power source cannot be used.**

Be sure to check the power source carefully, especially on a ship or other place where DC is used.

## ■ Grasp the plug when disconnecting the power supply cord

1. **Wet hands are dangerous.**

A dangerous electric shock may result if the plug is touched by wet hands.

2. **Never place heavy items on top of the power supply cord, and never force it to bend sharply.**

## ■ Place the unit where it will be well ventilated

Place this unit at least 10 cm (4") away from wall surfaces, etc.

## ■ Avoid places such as the following:

**In direct sunlight or in other places where the temperature is high.**

**In places where there is excessive vibration or humidity.**

Such conditions might damage the cabinet and/or other component parts and thereby shorten the unit's service life.

## ■ Be sure to place the unit on a flat, level surface

If the surface is inclined, a malfunction may result.

## ■ Never attempt to repair or reconstruct this unit

A serious electric shock might occur if this unit is repaired, disassembled or reconstructed by unauthorized persons, or if the internal parts are accidentally touched.

## ■ Take particular care if children are present

Never permit children to put anything, especially metal, inside this unit. A serious electric shock or malfunction could occur if articles such as coins, needles, screwdrivers, etc. are inserted through the ventilation holes, etc. of this unit.

## ■ If water is spilled on the unit

Be extremely careful if water is spilled on the unit, because a fire or serious electric shock might occur. Immediately disconnect the power cord plug, and consult with your dealer.

## ■ Avoid spray-type insecticides

Insecticides might cause cracks or "cloudiness" in the cabinet and plastic parts of this unit. The gas used in such sprays might, moreover, be ignited suddenly.

## ■ Never use alcohol or paint thinner

These and similar chemicals should never be used, because they might cause flaking or cloudiness of the cabinet finish.

## ■ Disconnect the power supply cord if the unit will not be used for a long time

If the unit is left for a long time with the power ON, this will not only shorten its useful operation life, but may also cause other troubles.

## ■ If trouble occurs

If, during operation, the sound is interrupted or indicators no longer illuminate, or if abnormal odor or smoke is detected, immediately disconnect the power cord plug, and contact your dealer or an Authorized Service Center.

# Installation

## Installation

### ■ Avoid locations nearby tuners or television sets.

Since this unit uses high-frequency signals, placing it near a tuner or television set may result in interference with the tuner/TV reception. If this kind of audio or video interference is experienced, move the DAT unit away from other AV components.

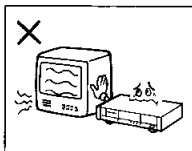

The some kind of phenomenon may occur when using an indoor TV antenna; whenever possible, use an outdoor antenna instead.

### ■ Precautions when using an indoor wire-strip antenna (T-antenna) with FM tuner.

- Separate the horizontal elements of the FM antenna at least 1.5 m from the tuner.
- Do not allow the feeder wire from an indoor or outdoor FM antenna to drape near the DAT unit. If excess feeder wire is present inside the room, coil it up as far as possible away from the DAT unit.

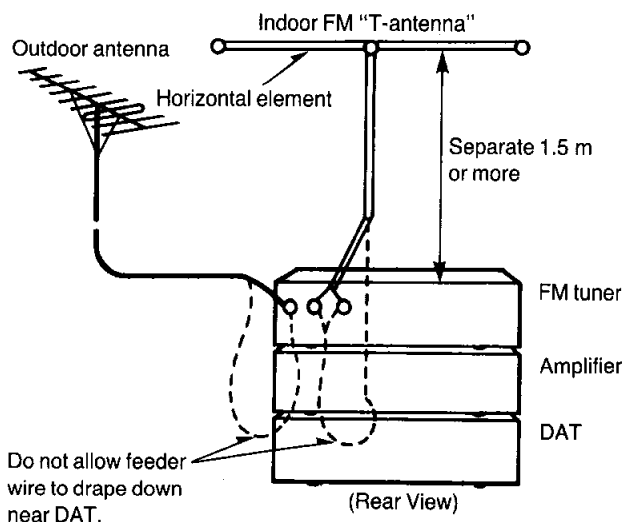

## Placement notes

### ■ This unit is a precision instrument. Be sure to place it on a flat surface.

### ■ Avoid places such as the following:

- Near any equipment or device that generates strong magnetism.
- On any heat-generating equipment or device, or in any place where the temperature is high (35°C or higher).
- Extremely cold places (5°C or below).
- Near a tuner or TV  
(It may cause noise in the broadcast, or disturbance of the TV picture.)
- For long periods of time in direct sunlight.
- In dusty or smoky locations.
- In locations prone to vibrations.
- In locations where the rear panel is less than 10 cm (about 4") away from the wall or back of an audio rack.
- Within reach of children.

### ■ When carrying or storing the unit, handle it with care so it is not subjected to any strong bumps.

### ■ To avoid problems due to vibration.

- Do not place a book or similar object under this unit.
- Do not route the connection cables (of this or other units) across the operation panel, across the top, or under the unit.

## DAT head and tape transport cleaning

As with any tape based recording media, the head and transport may become contaminated due to exposure to dust or dirt. To maintain the best possible recording/playback, we recommend periodic cleaning.

Depending on how dirty the head and/or mechanism becomes, the **cleaning** indicator will flash. In such a case, playback the optional cleaning tape (RT-RCLP), according to the following procedure:

1. Insert the head cleaning tape.
2. Press the play button, let the tape play for 15~20 seconds, then press the stop button.
3. Remove the cassette without rewinding it.
4. Check the recording and playback sound quality.

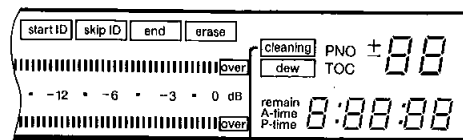

cleaning indicator

- Cleaning tapes cannot be used for recording or playback (be sure to read the operating instructions supplied with the tape).

- If sound quality does not improve after two consecutive cleanings, consult your dealer.

- If playback quality improve after cleaning, but then deteriorates immediately after recording of playback, the tape has probably reached its usefulness. In this case, use a new tape.

# Connections

Turn power off on all components before making connections.

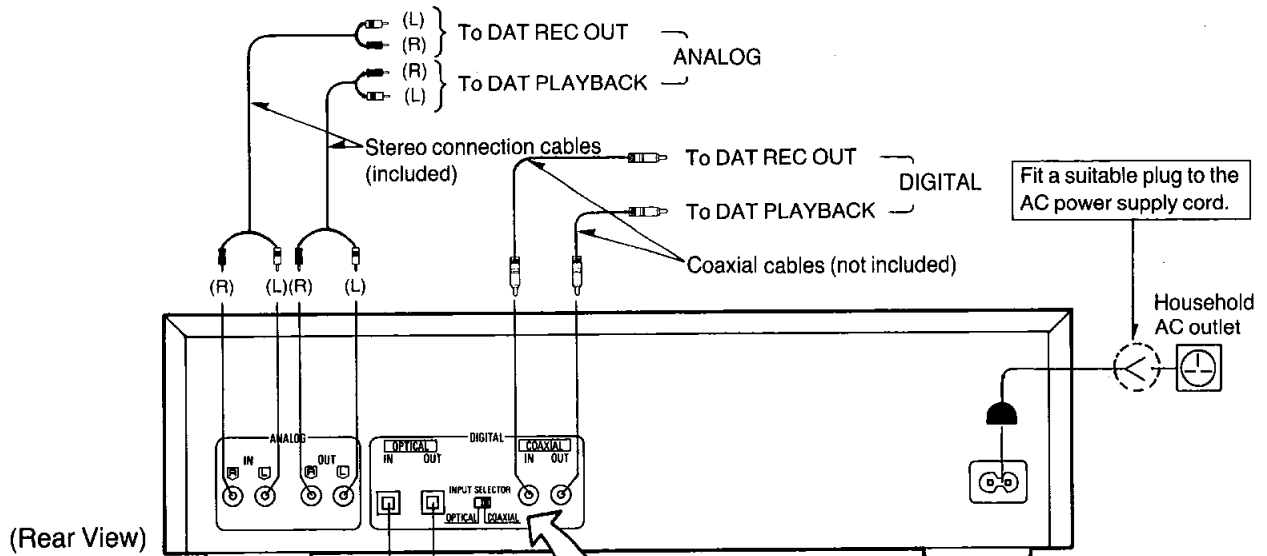

## •Optical input terminal (DIGITAL IN/OPTICAL)

This terminal can be used for connection with other equipment that has a digital output terminal, such as an amplifier, by using an optical cable (optional).

## •Optical output terminal (DIGITAL OUT/OPTICAL)

This terminal can be used for connection with other equipment that has a digital input terminal, such as an amplifier, by using an optical cable (optional).

**DIGITAL INPUT SELECTOR**  
 Select the setting when connecting to digital terminals.  
 When using optical fiber cables, set the selector to "OPTICAL".  
 When using coaxial cables, set the selector to "COAXIAL".

## About Optical Fiber Cables

### To connect optical fiber cables

- (1) Remove the dust cap from the terminal.
- (2) Connect the cable.

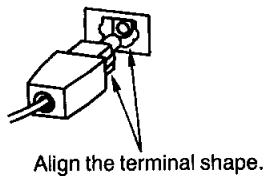
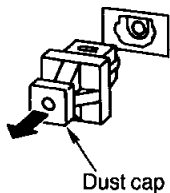

### Notes:

- Do not attempt to bend optical fiber cables at severe angles.
- Be sure that connections are made securely.
- Store the dust cap securely, and replace it whenever cables are not connected to the terminals. If dust is allowed to enter the terminal connector, signal errors may result.

### About OPTICAL connector

When the optical connectors are used, electrical signals are converted into light signals for transmission between units, making the signals impervious to adverse effects from external noise. This form of connection thus allows the highest quality of digital audio signal transmission.

## Precautions when using this unit's DIGITAL OUT connection

If this unit is connected incorrectly to your stereo amplifier, a recording feedback loop may occur within which the DAT unit's output is fed back into the DAT unit for recording, resulting in and possible damage to your speakers. Be sure to abide by the following precautions:

- 1) When using the unit's DIGITAL IN/OUT terminals for recording or playback, be sure to connect only to your amplifier's DIGITAL REC OUT (OUTPUT) and DIGITAL PLAYBACK (INPUT) terminals.
- 2) If your amplifier has no DIGITAL PLAYBACK or DIGITAL REC OUT terminals, and you make your connections to the amplifier's conventional DIGITAL INPUT terminals for playback, be sure to use this unit (DAT recorder) for playback only (not for recording).
- 3) If your unit is used for recording when connected as described in step 2 above, do not set the DAT unit's INPUT SELECTOR to the DIGITAL position.

# Remote Control Transmitter

## Insertion of remote control transmitter batteries

Battery life is about 1 year.

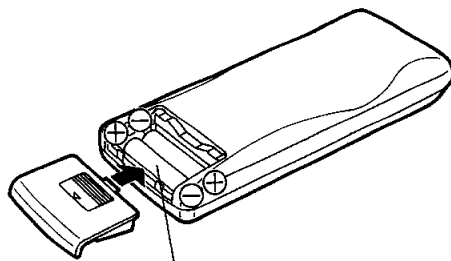

Use two UM-4,  
"AAA" (R03) size  
(1.5 V) batteries.

### ■ Notes concerning use of batteries

- Do not use rechargeable batteries (Ni-Cd type).
- Be sure the batteries are inserted so that the positive (+) and negative (-) polarities are correct. Batteries installed with incorrect polarities may leak and damage the remote control transmitter.
- Never subject the batteries to excessive heat or flame; do not attempt to disassemble them; and be sure they are not short-circuited.
- If the remote control transmitter is not to be used for a long time, remove the batteries.
- Remove old, weak or worn-out batteries promptly and dispose of them.
- Never mix old and new batteries, nor batteries of different types (carbon or alkaline).

## Remote control transmitter operation notes

Note that operation may not be correct if direct sunlight or other strong light strikes the remote control signal receptor part of this unit. If there is a problem, place the unit away from the direct sunlight or other strong light source.

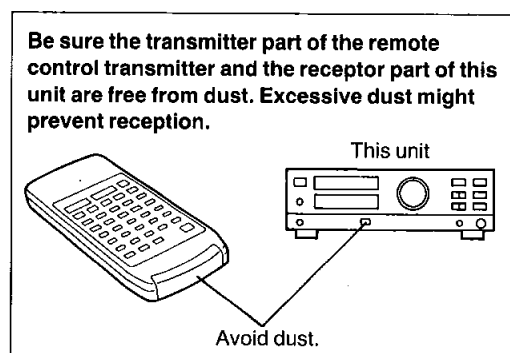
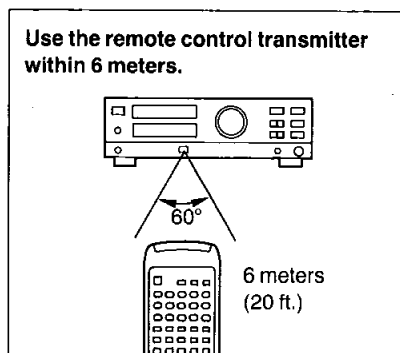
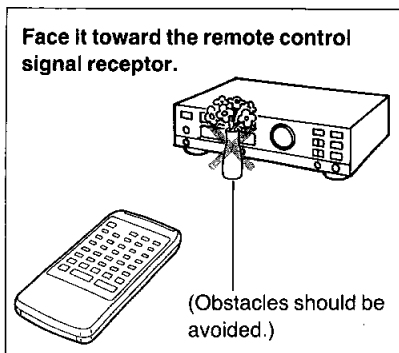

### Notes:

- The control panel of the remote control transmitter may be covered by a clear protective sheet. This sheet may be removed if desired.
- If this unit is installed in a rack with glass doors, the glass door's thickness or color might make it necessary to use the remote control transmitter a shorter distance from the unit.
- Do not use a remote control transmitter for a TV set, VCR or other component at the same time as this unit's remote control transmitter is being used, because this could result in an operation error.

# Location of Controls

The functions indicated by the black numbers (with white background, ④ etc.) can also be activated using the remote control transmitter.

## Front panel

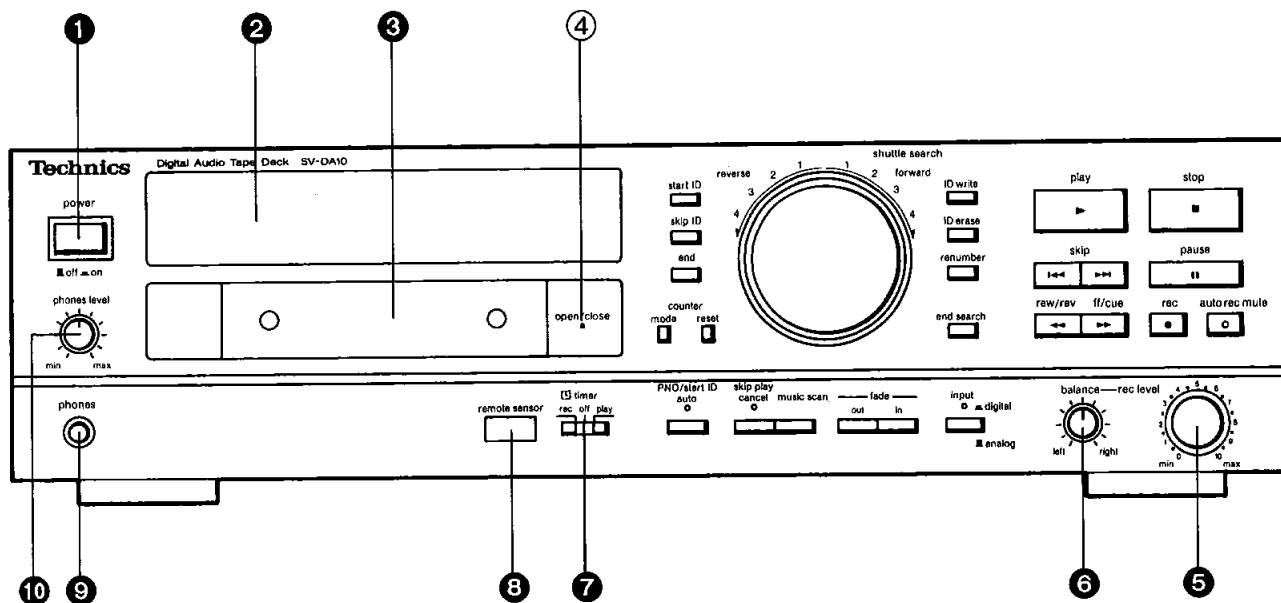

① Power switch (power)

② Display panel  
(Refer to page 10.)

③ Cassette holder

④ Open/close button ( $\blacktriangle$  open/close)

⑤ Rec level control (rec level)  
Use to adjust the recording level of left and right channels.

⑥ Rec balance control (balance)  
Use to adjust recording balance between left and right channels.

⑦ Timer Selector ( $\square$  timer)  
Used to automatically begin playback or record when the unit is connected to an AC line timer. Setting this switch to "rec" or "play" causes the unit to switch to record or playback mode as soon as AC power is applied.  
If a timer is not used, leave this switch in the "off" position.

⑧ Remote control signal sensor (remote sensor)

⑨ Phones jack (phones)  
A 6 mm ( $\frac{1}{4}$ " ) connector for standard stereo headphones.

⑩ Phone level control (phones level)  
Use this control to adjust the output level to the headphones.

## Front panel

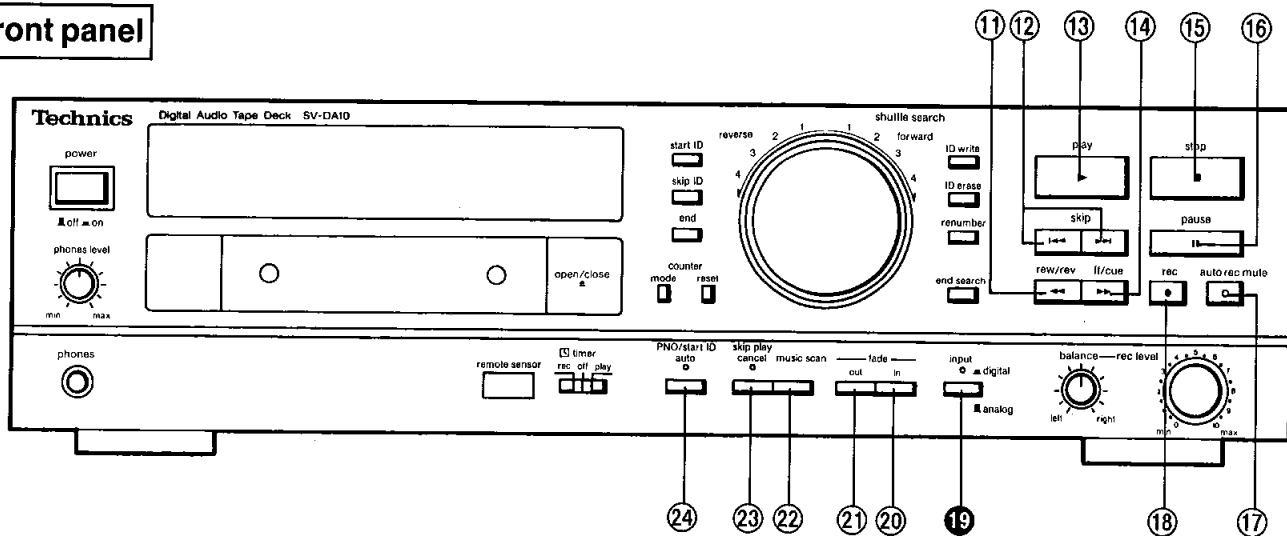

**11 Rew/rev button (◀◀ rew/rev)**

Use to rewind the tape or for audible high-speed search in play mode (review).

**12 Skip buttons (◀◀•▶▶| skip)**

Use the skip buttons to advance to the desired program. The ▶▶ button skips the program forward. The ◀◀ button skips the program backward. Repeated pressing of the skip buttons causes the unit to skip forwards or backwards several programs.

**13 Play button/indicator (▶ play)**

Use to initiate recording or playback mode. Use also to record program numbers manually.

**14 Ff/cue button (▶▶ ff/cue)**

Use to advance the tape rapidly or for audible high-speed search (cue).

**15 Stop button (■ stop)**

Use to stop all functions. This button also clears the program memory.

**16 Pause button/indicator (|| pause)**

Use to temporarily interrupt playback or recording mode.

**17 Auto rec mute button (◻ auto rec mute)**

Use to automatically insert a silent space approximately four seconds long during a recording.

**18 Record button/indicator (● rec)**

Use to place the unit in record standby mode.

**19 Input selector button/indicator (input)**

Use to select digital or analog recording input.

**20 Fade in button (fade in)**

Use to start recording increasing the level of sound gradually for approx. 2½ seconds.

**21 Fade out button (fade out)**

Use to cease recording reducing the level of the sound gradually for approx. 5 seconds.

**22 Music scan button (music scan)**

Use to play back the beginning of each recorded program on the tape for about 15 seconds. This is useful for quick identification of program contents.

**23 Skip play cancel button/indicator (skip play cancel)**

Use to release skip mode.

**24 PNO/start ID auto button/indicator (PNO/start ID auto)**

Use to automatically record program numbers or start ID's during recording or indexing by detecting the beginning of signal after a blank position.



## Front panel

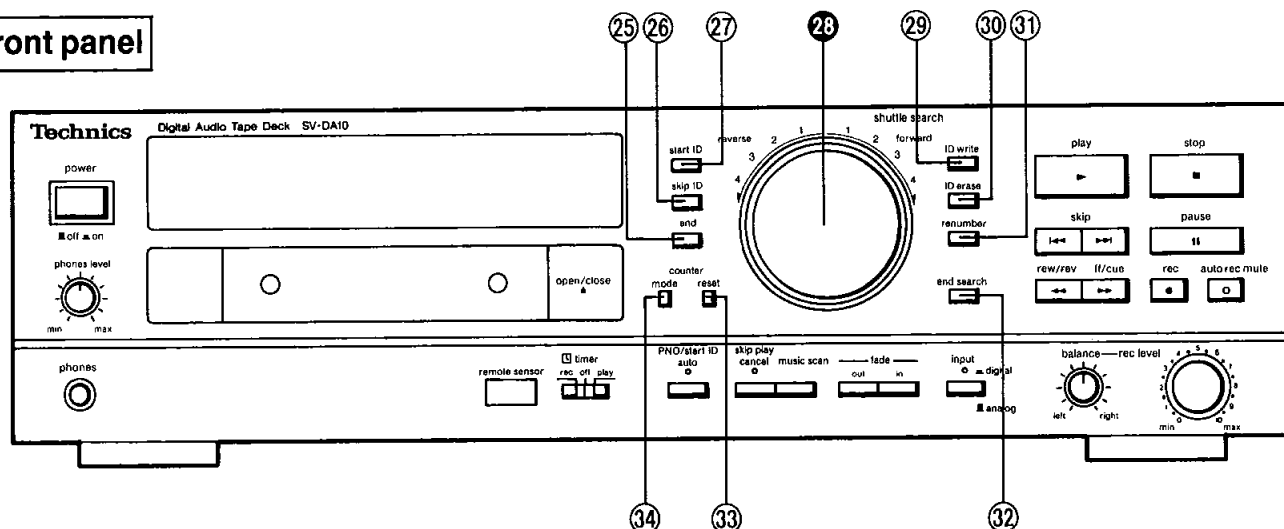

### 25 End button (end)

Use to record an end mark on a recording.

### 26 Skip ID button (skip ID)

Use to enter the skip ID mode.

### 27 Start ID button (start ID)

Use to enter the start ID mode.

### 28 Shuttle search dial (shuttle search)

Use to locate specific places on the tape during play and pause mode at high speed, in either forward or reverse directions.

### 29 ID write button (ID write)

Use to record start or skip ID's during indexing\*.

\*Indexing allows certain DAT subcode data that has been recorded on the tape to be changed without affecting to the actual program recording.

With this unit, the following types of indexing are possible.

1. Recording or erasure of start ID's at the beginning of a program
2. Recording or erasure of skip ID's
3. Renumber function

### 30 ID erase button (ID erase)

Use to erase start or skip ID's during indexing.

### 31 Renumber button (renumber)

Use to assign program numbers (01, 02, 03...) to start ID's recorded during indexing.

### 32 End search button (end search)

Use to advance at high speed to the end of the recorded portion of the tape.

Use also to continue recording from the last recorded position, or to find the total number of programs or total time recorded on the tape (in the case of tapes where absolute time and program numbers have been recorded).

### 33 Counter reset button (counter reset)

Use to reset the tape counter to "0000" (when the display mode is set to tape counter).

### 34 Counter mode button (counter mode)

Use to select the desired counter mode.  
(absolute time, program time, remain time, TOC, tape counter)

## Display panel

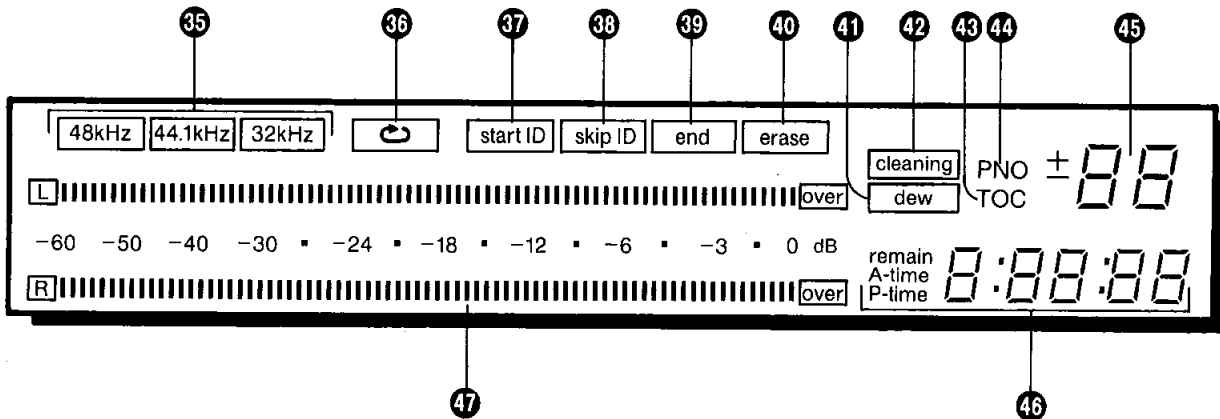

### 35 Sampling frequency indicators

Displays sampling frequency of digital signals during recording or playback.

Changes automatically depending on the input signal.

### 36 Repeat indicator

This indicator is used for the repeat loop-play function.

Indicates that all programs or memorized programs can be played back repeatedly (  ).

### 37 start ID indicator

Indicates that a start ID is being or has been recorded.

### 38 skip ID indicator

Indicates that a skip ID is being or has been recorded.

### 39 end indicator

Indicates that an end mark is being or has been recorded.

### 40 erase indicator

Indicates that a start ID or skip ID is being erased.

### 41 dew indicator

Indicates the formation of dew within the unit.

### 42 cleaning indicator

Indicates that the DAT heads need cleaning.

### 43 TOC (table of contents) indicator

Indicates the total program count and tape length of a tape onto which the TOC information has been recorded.

### 44 PNO (program number) indicator

Indicates the number of the current program.

### 45 Program number display

Displays the TOC information when TOC indicator appears.

Displays the number of the program when PNO indicator appears.

### 46 Counter display panel

The following are displayed according to the setting of the counter mode button:

- 1) absolute time  
This display is always shown when power is first switched on.
- 2) program time
- 3) remaining time
- 4) TOC information
- 5) tape counter

### 47 Peak level meter

Recording level in recording and playback level in playback are indicated by a bar graph.

## Remote control transmitter

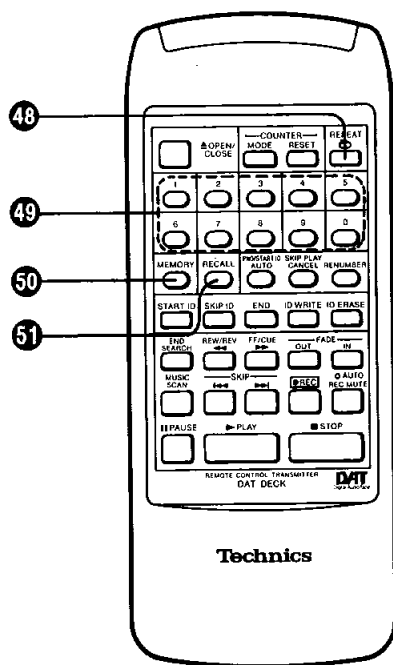

- 48 REPEAT button (REPEAT ↺)**  
Use for a repeat playback of a tape or a programmed sequence.
- 49 PROGRAM buttons (1~9, 0)**  
Use to select program numbers, to cue to a desired program, etc.
- 50 MEMORY button (MEMORY)**  
Use to program a random playback sequence.
- 51 RECALL button (RECALL)**  
Use to display and check program numbers that have been memorized.

Unnumbered buttons on the remote control transmitter function identically to their corresponding parts on the unit.

# Basic Operations for Recording and Playback

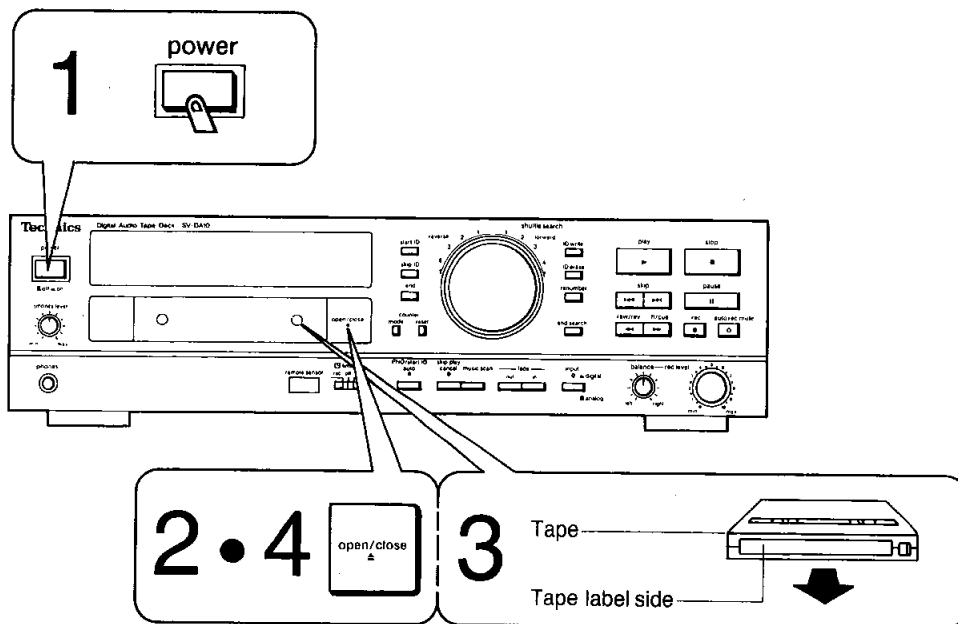

**1** Press the power switch to switch on power.

**2** Press the open/close button.

The cassette holder will open.

**Notes:**

- During recording, this button does not operate.
- When removing tape, first press stop button and then press this button in the recording or playback mode.

**3** Insert a cassette tape.

Insert the tape gently into the opening.

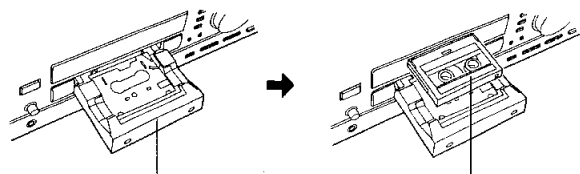

Cassette holder

Insert a cassette correctly so that the tape reels are visible.

**Note:**

Do not force the cassette holder.

**4** Press the open/close button

The cassette tape will be loaded automatically into the rotating mechanism. While the cassette holder is being opened or closed, the counter display panel will flash. When the display is flashing, the control buttons will not operate.

## Inserting and Removing Cassette Tapes

When inserting and removing tapes, the time on the counter display panel or the tape counter display may shift a little, but this is not a malfunction.

- When the cassette tape has been inserted, the counter display panel shows:

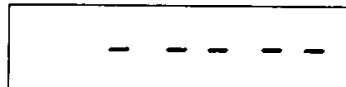

- When the cassette tape has not been inserted, no display will be shown.

## Counter mode on display panel

- When the power is switched on with a cassette tape in the unit, absolute time is not displayed on the counter display panel.
- If recording operations are carried out in this mode, continuous recordings cannot be made in absolute time. In this case, first operate the play button, perform an end search, or rewind tape to the end to convert the display to absolute time. Then, carry out normal recording operations.

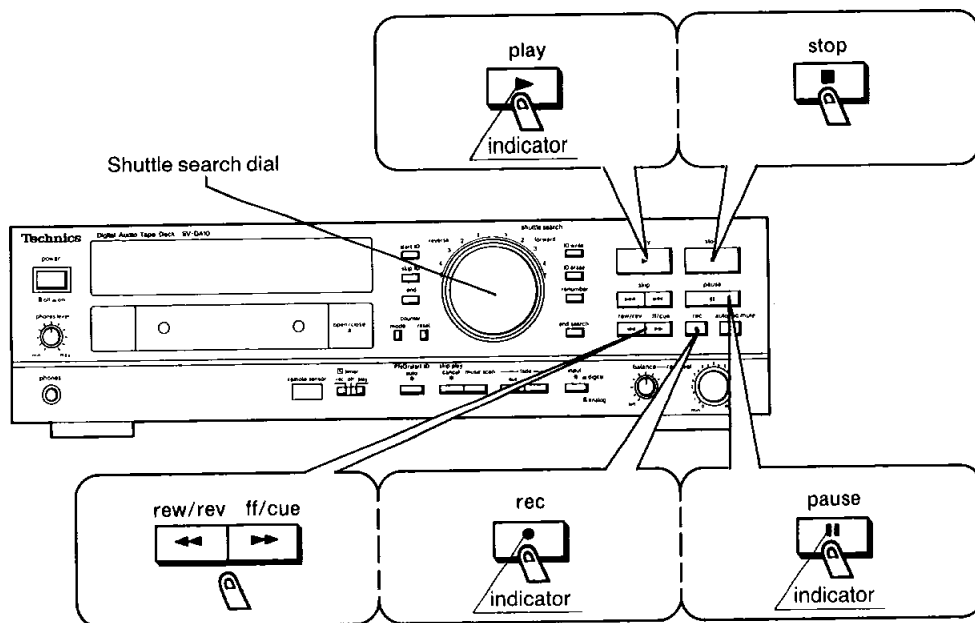

**To Begin Recording or Playback**

**Press the play button.**  
The play indicator illuminates, and play begins.

**Press the rec button and then press the play button.**  
The rec and play indicators illuminate, and recording starts.

**To Interrupt Recording or Playback Temporarily**

**Press the pause button.**  
The pause indicator illuminates, and recording or playback stops temporarily.

**Press the play button to resume play.**

**To Stop Recording or Playback**

**Press the stop button.**  
Recording or playback stops.  
In the case of programmed play, the memory is also cleared.

If the unit is not going to be used for extended periods, rewind the cassette tape back to the beginning, remove it and turn off the power.

**Rewind Play, Fast-Forward Play (During playback)**

**When the fast-forward button or rewind button is kept depressed:**  
Advances or reverses the tape during playback at about 3 times normal speed (does not operate during recording).

**Rewind, Fast-Forward (During stop mode)**

When pressed once, the tape advances/reverses at about 250 times normal speed; when pressed twice, the tape advances/reverses at about 400 times normal speed. Each subsequent press causes alternate switching between the 250 times and 400 times speeds.

**Note:**  
When operating the "Cue" or "Review", the monitor sounds will have some noise caused by the head crossing over the recorded track on the slant.  
Reduce the volume of the amplifier to optimum level. (Take special care during playback with digital output signals.)

This unit is also provided with a shuttle-search function; the shuttle dial can thus be used to perform rewind play and fast-forward play. For details, see page 32.

**Learnig search function**  
This unit comes with a learning function which memorizes once-passed program positions either by normal playback or by fast forwarding or rewinding at 250 times normal tape speed.  
Therefore, when a once-passed program number has been assigned, the function will automatically search a program at up to 400 times normal tape speed.  
(If, however, the program to be searched is located close to the present tape position, the tape will not be accelerated up to 400 times normal tape speed.)

# Counter Display

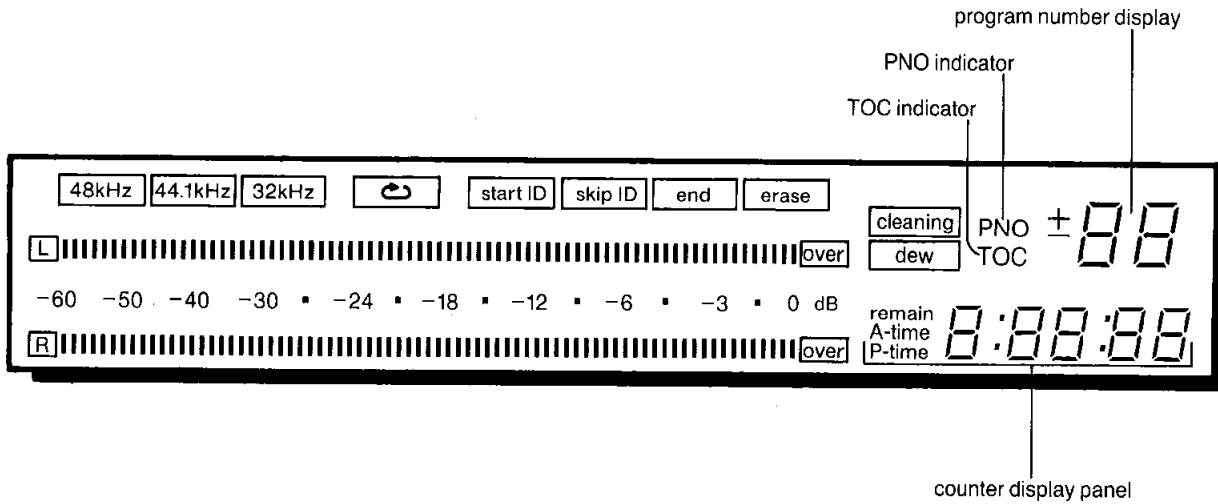

## When the subcodes are recorded on the tape

The following information appears on the counter display.

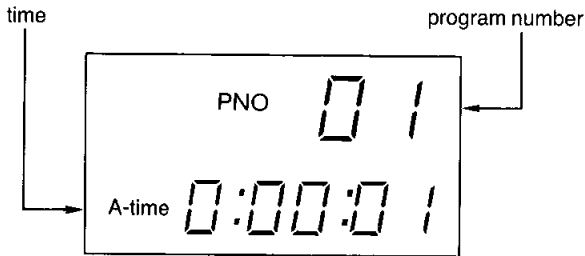

## When the tape comes to the end

When the tape comes to the end in the playback mode, it is automatically rewound to the start of the tape.

**(Auto rewind function)**

When the tape approaches the end using the fast forward or search function, it stops and "E" (end) appears on the display.

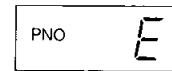

## When the subcodes are not recorded on the tape (when a brand-new tape is used)

The bar moves from left to right.  
(The bar moves from right to left during review or rewind.)

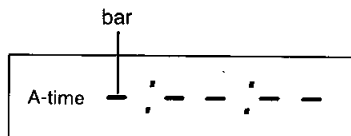

The bar also appears on the following cases.

- When searching 400 times normal speed.
- The program time is not identified.
- The remain time is being calculated.

## Counter display mode

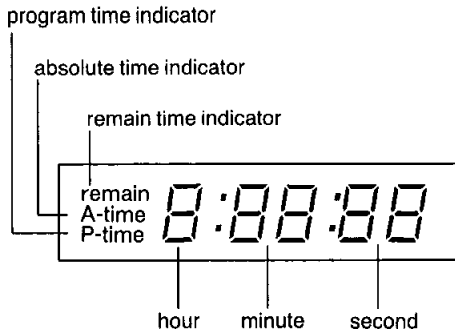

- 1 absolute time**  
 This is the total time recorded on the tape from the beginning. If this time is not recorded when a recording is made, it will not be displayed during playback.
- 2 program time**  
 This is the elapsed time for each program.
- 3 remain time**  
 This is the time remaining on the tape.
- 4 TOC (Table of Contents)**  
 This is the total time of the recorded programs. Timing information is displayed only when the TOC data is entered.
  - When the sampling frequency indicator flashes, digital recording cannot be performed.
- 5 tape counter**  
 This is a number corresponding to the number of revolutions of the tape reel.

## To change counter display mode

### Counter mode

Counter mode changes in the order as shown below each time the button is pressed.

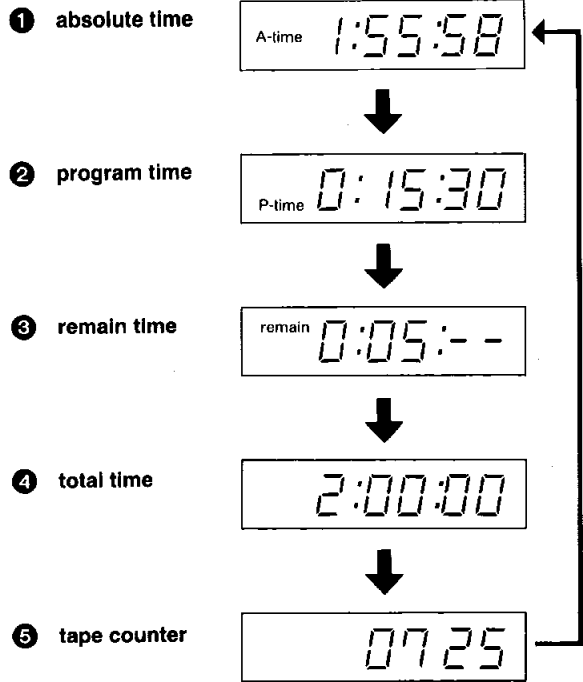
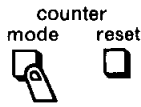

### Tape counter

Use to reset the tape counter to "0000" (when the display is set to tape counter).

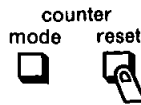

# Playback

## To Play the Tape from the Beginning

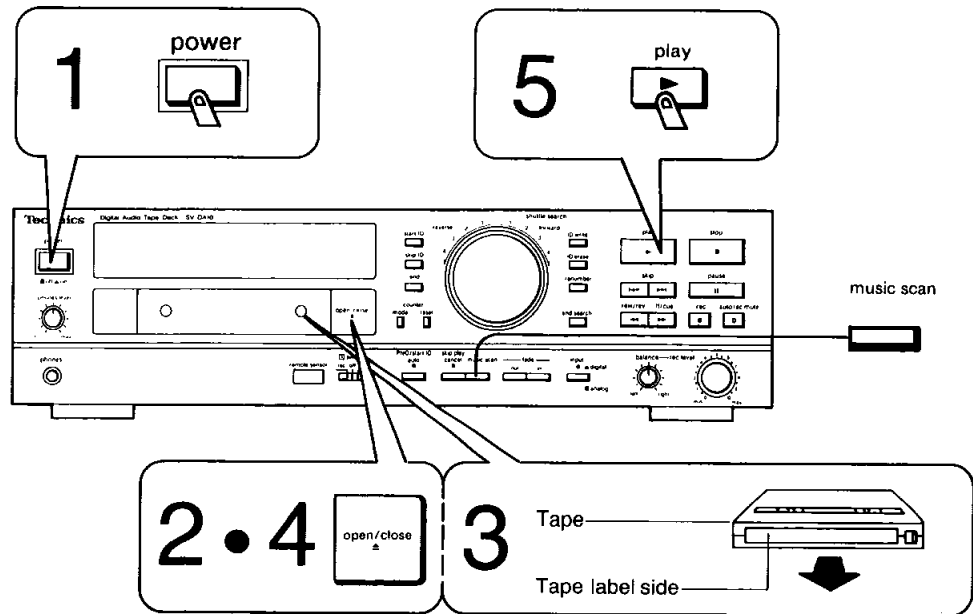

- 1 Switch ON the power switch.
- 2 Press the open/close button to open the cassette holder.
- 3 Insert the cassette tape into the cassette holder.
- 4 Press the open/close button again to close the cassette holder.  
By pressing the "playback", "fast-forward", or "rewind" button, the cassette holder will close automatically.

- When absolute time, program times and program numbers have been recorded on the tape, times are displayed on the counter display panel, and program numbers during playback are displayed on the program number display.

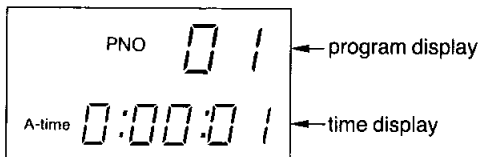

In the above diagram, one second of the first tune has elapsed (when counter mode is absolute time).

- For tapes where absolute time or program times have not been recorded, time codes are not displayed.

The bar display below shows that absolute time has not been recorded.

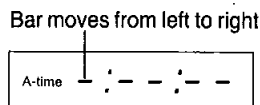

In these cases, play the tape using the tape counter.

- 5 Press the playback button.  
The play indicator will illuminate, and playback will begin.

The tape runs, and when it comes to the end, the sign " E " (end) is displayed on the program number display as shown in the diagram below.

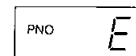

## To Identify the Contents of Each Program Recorded on the Tape (Music Scan Play)

Press music scan button.

- The beginning of each tune from which music scan button is pressed will be played for approx. 15 sec, and the play indicator will flash.
- When the final tune is played, the tape is rewound to the beginning.
- To interrupt the scan, press the stop button.
- If a desired tune is found during scanning, press the play button to continue playback.  
When the unit is changed to the playback mode, the play indicator will illuminate.

### Note:

Music scan does not function during program play.



# Playback of any Desired Tune (Access Play)

By specifying a tune and pressing the play button, playback will begin from that tune. This page explains how to do this starting from the stop mode when the tape is at the beginning.

**Notes:**

- This operation cannot be performed with tapes which have no program numbers recorded on them.
- It may not be possible to find short tunes less than 1 minute long.

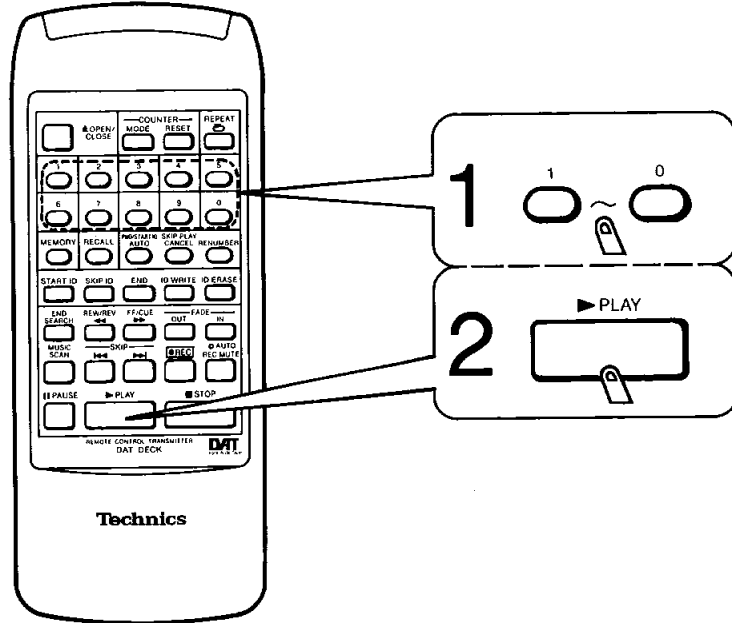

## 1 Select the desired program number with the program button ( 0 ~ 0 ) on the Remote Control.

The program number will appear on the program number display.

When the 0 button is pressed

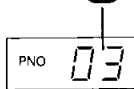

## 2 Press the PLAY button.

The play indicator illuminates, and play begins from the specified program number.

While the program number is being searched, the play indicator will flash.

### TO CUE THE MACHINE TO A DESIRED TUNE

• If a desired tune is specified and the pause button is pressed, the specified tune is searched and the unit enters the pause mode. While the tape is searching for each tune, the pause indicator will flash.

To begin playback, press the play button.

• In this access play mode, programs are searched at approx. 200 times normal speed.

At the beginning or near the end of the tape, however, the speed drops to approx. 100 times normal speed.

### Example: To begin playback from 10th tune

Press 1 → 0 → PLAY buttons in that order.

• The unit searches for the specified program, playback begins and the program is displayed on the program number display.

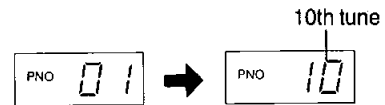

### To change a specified program (only effective in stop mode)

Press the 0 button twice, then press the correct button for the desired selection.

# To Skip Programs (Skip Play)

**Notes:**

- This function may not operate correctly in the case of very short tunes (about 30 sec or less).
- This function is different from auto-skip play in indexing.

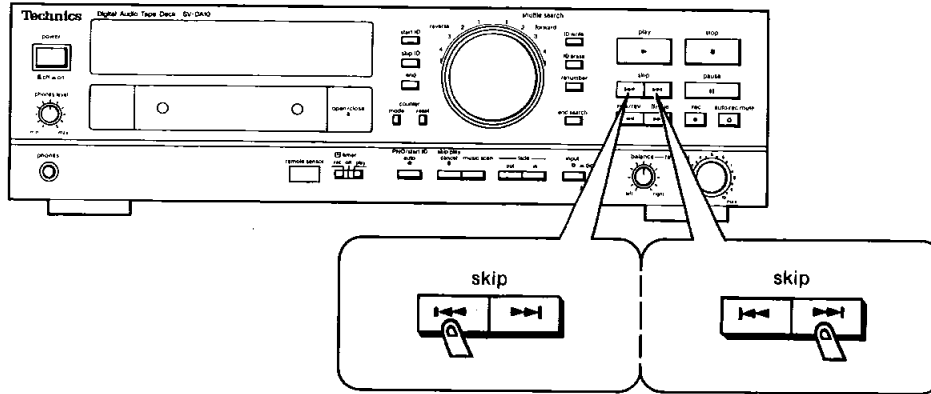

## To Skip Forward (Forward Skip Play)

Press the ►► button so that the number of programs you want to skip are displayed in the program number display. The number of times the button is pressed is shown in the display. When the ►► button is pressed, a "+" sign is also displayed.

When the button is pressed once

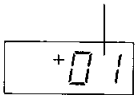

When the button is pressed twice

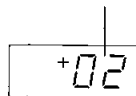

Each time the button is pressed, the tape advances to the beginning of the next tune. Play will then begin from that tune. (During pause mode, the unit then returns to pause mode.)

## To Skip Backward (Reverse Skip Play)

Press the ◀◀ button so that the number of programs you want to skip are displayed in the program number display. The number of times the button is pressed is shown in the display. When the ◀◀ button is pressed, a "-" sign is also displayed.

When the button is pressed once

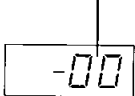

When the button is pressed twice

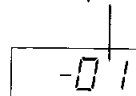

Each time the button is pressed, the tape skips back to the beginning of the tune being played, then to the beginning of the previous tune. Play will then begin from that tune. (During pause mode, the unit then returns to pause mode.)

**Note:**

During reverse skip, the tune now being played is counted as one skip.

## Skip During Program Play

Each time the skip button is pressed during program play, the program sequence changes and is displayed.

**Forward Skip**

If the 2nd, 4th, 6th, 8th and 10th programs have been memorized, for example, and the ►► button is pressed while the 6th selection is being played, the tape advances to the 8th selection. If the button is pressed again, it advances to the 10th selection, and soon.

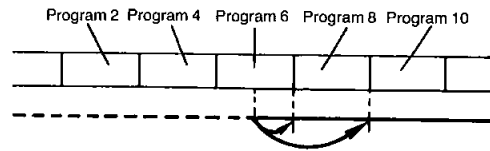

In forward skip, if no further programs have been memorized,

the sign PNO E is displayed.

**Reverse Skip**

If the 2nd, 4th, 6th, 8th and 10th programs have been memorized, for example, and the ◀◀ button is pressed while the 6th selection is being played, the tape goes back to the beginning of the 6th selection. If the button is pressed again, the tape goes back to the beginning of the 4th selection.

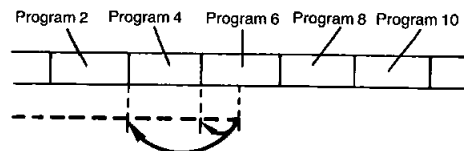

## To Playback Tunes in any Desired Order (Program Play)

**Note:**

This function cannot be used with tapes on which program numbers have not been recorded.

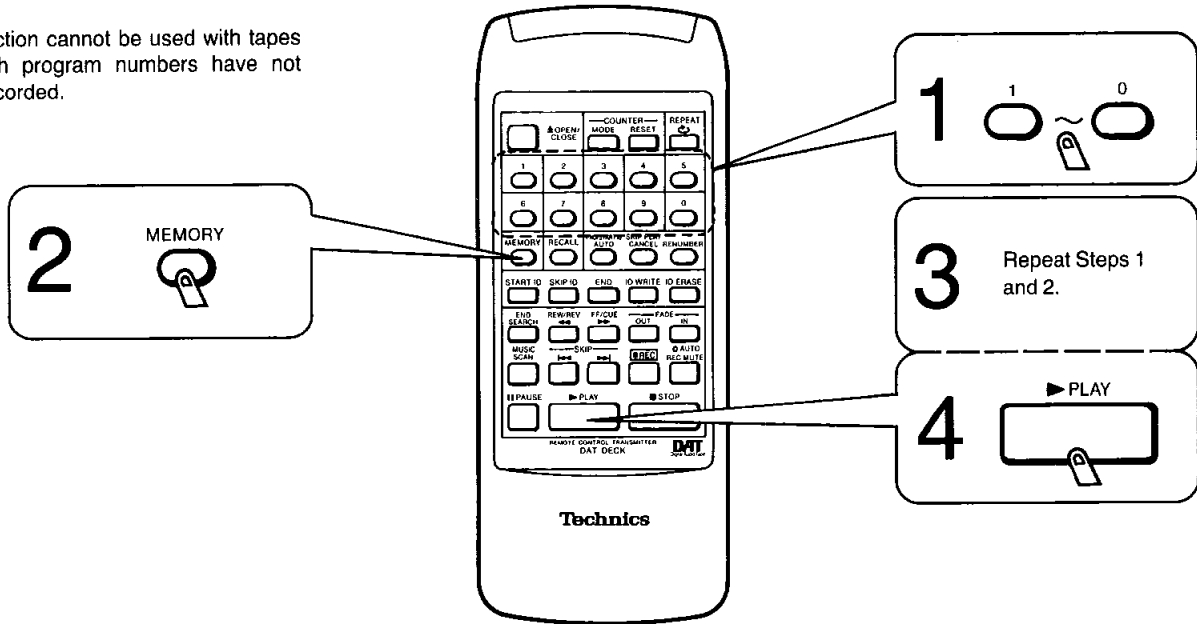

### Procedure When Unit is in Stop Mode

- 1 Select the desired tunes with the program buttons (0 ~ 9) on the Remote control.**  
The tunes selected will appear in the program number display.

First selection (3rd tune)

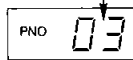

- 2 Press the MEMORY button to memorize a specified tune.**

Memorized as first selection

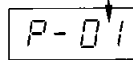

- 3 Repeat Steps 1 and 2 to memorize tunes in a desired order.**

A total of 32 steps can be memorized.

- 4 Press the PLAY button.**

**Playback begins from the first selection.**

When the tape is searching for the beginning of selections, the play indicator flashes.

After memorizing, if the PAUSE button is then pressed, the first selection is searched and the unit enters the pause mode.

### To Change Program Selections

If it is desired to change some selections and the MEMORY button has not yet been pressed, press the 0 button twice to cancel the incorrect selections, then enter the correct selections. When the MEMORY button has already been pressed, pressing the STOP button cancels all selections.

### To Interrupt Program Play

Press the STOP button.

**To play tunes 3, 5 and 8 in that order**

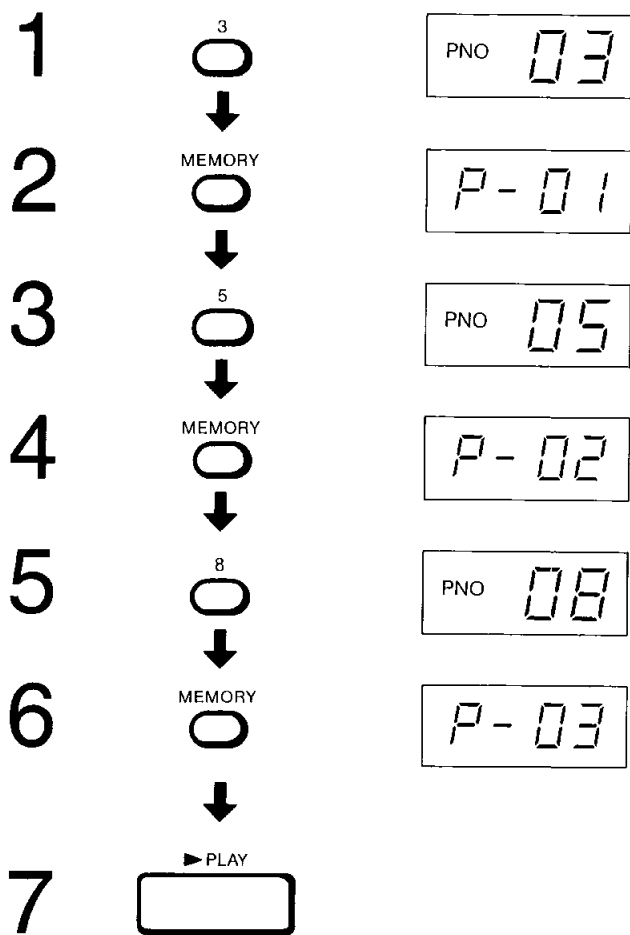

**To Confirm Memorized Program Selections**

If for example, tunes 3, 5 and 8 have been memorized in that order, and the RECALL button is pressed while tune 3 is playing, the display will change as follows:

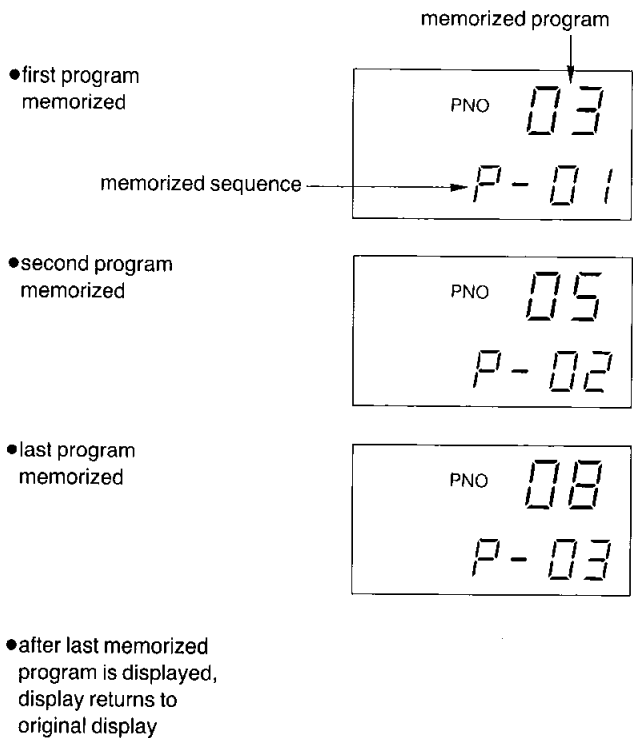

•When the last program has been played, the tape is rewound to the beginning and the unit enters the stop mode.

**Note:**

If there is an unrecorded space of 2 seconds or more on the tape, the tape will automatically advance to the next programmed selection.

## To Play a Tape Repeatedly (Repeat Play)

(The operations described on this page start from when the unit is in the stop mode).

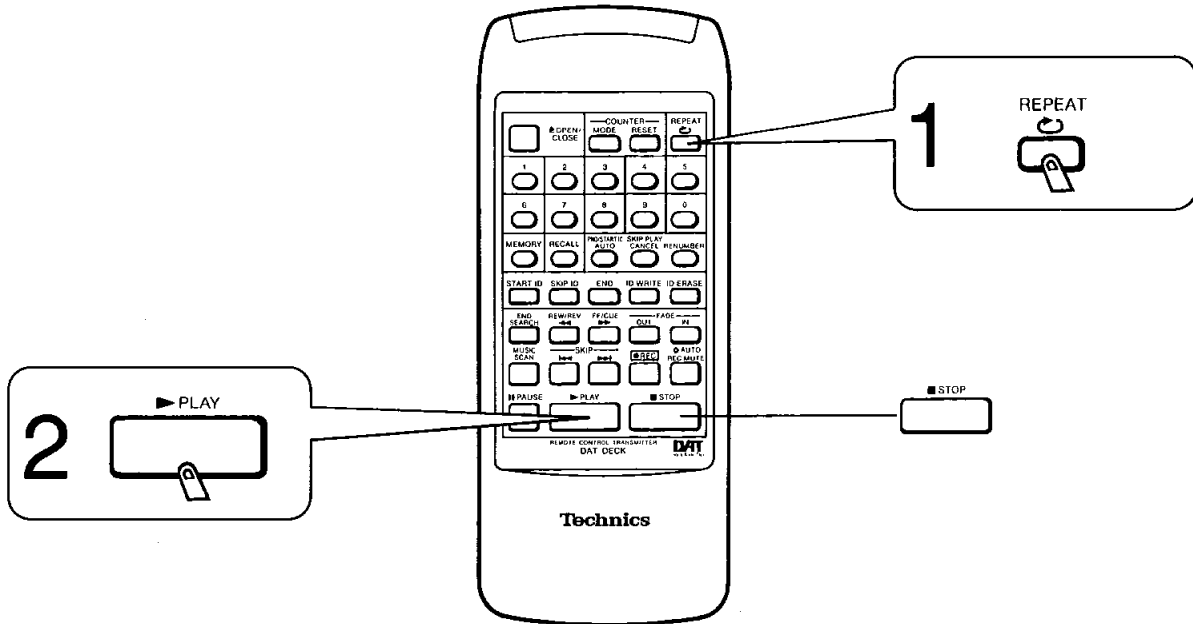

### To play all tunes or only memorized tunes repeatedly

All tunes, or in program play only memorized tunes, may be played repeatedly up to a maximum of 16 times.

**1 Press the REPEAT button.**  
The  indicator illuminates.

**2 Press the PLAY button.**  
The play indicator illuminates, and play begins.  
Unless the function is cancelled, the tape will be played repeatedly 16 times, after which it will stop automatically.

**Note:**

If all the tunes are to be played repeatedly and an end mark is detected, the tape will return to the beginning and playback will begin again.

### To Cancel Repeat Play

● **Press the REPEAT button.**

The  indicator turns off and the unit returns to the original playback mode.

● **If the STOP button is pressed, repeat play is cancelled, and the tape stops.**

# Before Recording

Your attention is drawn to the fact that recording pre-recorded tapes or discs on other published or broadcast material may infringe copyright laws.

## To Record Absolute Time

It is very convenient for playback or making consecutive recordings if absolute time is always recorded.

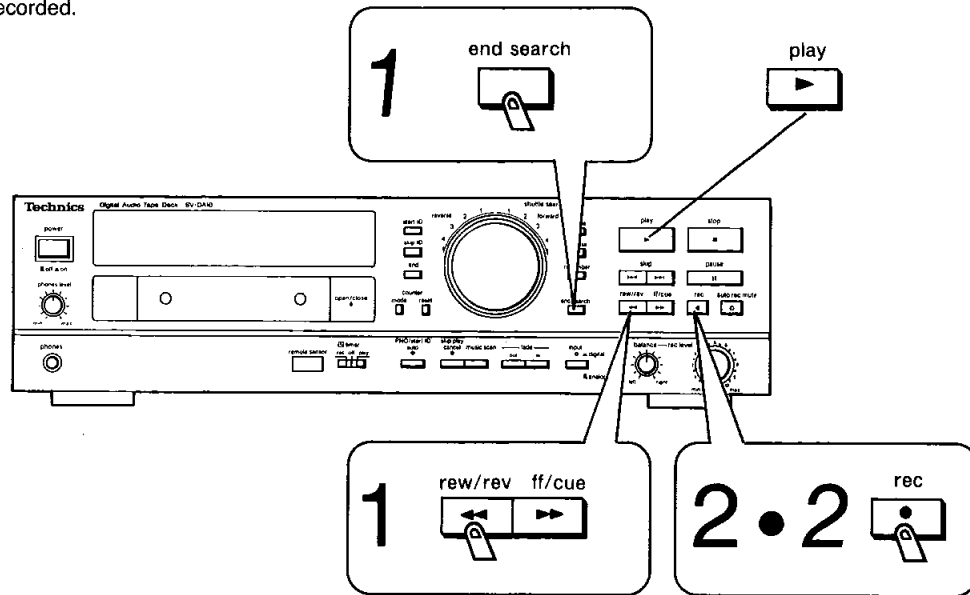

## To Record from the Beginning of a Tape

For recording on new tapes or recording while erasing on previously recorded tapes.

**1 Press the rew/rev button.**  
The tape is rewound to the beginning.

**2 Press the rec button.**  
The rec and play indicators illuminate for about 4 sec, and the pause indicator flashes (this is because the previous recording is being erased). The play indicator then turns off, and the pause indicator will turn on steadily, indicating record standby mode. At this point, pressing the play button initiates record mode.

## To Record on the Unrecorded Portion of a Tape

For recording on a tape which has already been partially recorded.

**1 Press the end search button.**  
The end of the last recording on the tape is searched at high speed, and the tape stops.

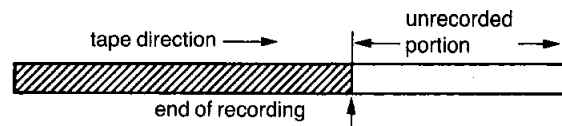

While the end search is being carried out "EE" appears on the program number display.

**Note:**  
In the case of tapes with a very short recorded portion (one minute or less), this function may not operate correctly.

**2 Press the rec button.**  
The rec and pause indicators illuminate, and absolute time will then be recorded once the play button is pressed.

**Note:**  
Even with new blank tapes, the tape must be rewound once or end search performed, otherwise absolute time will not be recorded.

# To Record Program Numbers

If program numbers are placed on the tape during recording, program play or access play can easily be performed during playback. There are two ways of recording program numbers:

- a) Automatic recording
- b) Manual recording

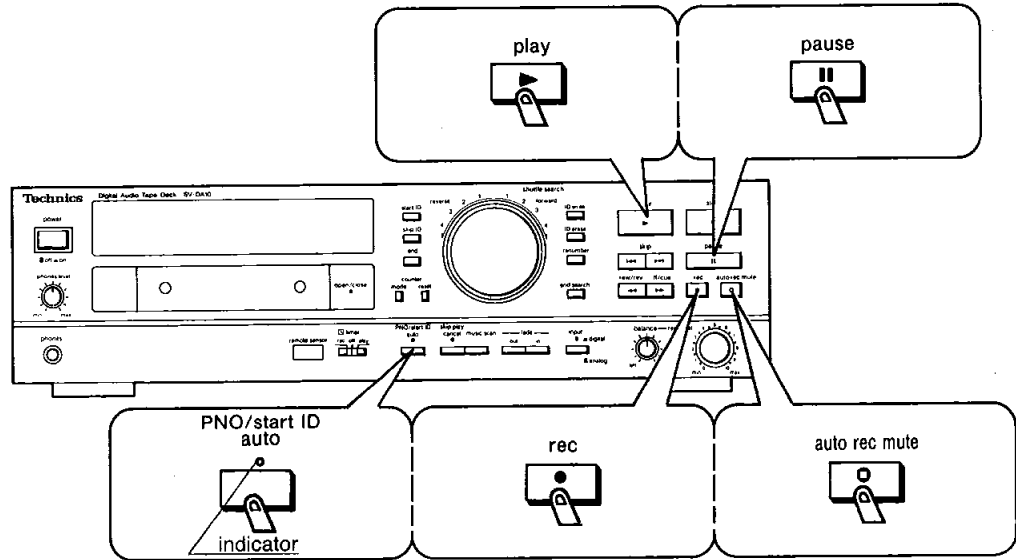

## Automatic recording of program numbers

- 1 The "AUTO" mode is selected automatically at power-up.**  
Press the PNO/start ID auto button if the PNO/start ID auto indicator is not illuminated.
- 2 Perform recording operation.**  
When recording has started, program numbers are recorded automatically when the sound begins or after a silent space of about 2 seconds or more. On all subsequent occasions when this condition is satisfied, program numbers are recorded in order (tune 01, 02, 03...), and are indicated in the program number display.



## To Cancel the Automatic Program Numbering Function

Press the PNO/start ID auto button.

## Manual Recording of Program Numbers

- 1 Make sure the PNO/start ID auto indicator goes out.**  
Press the PNO/start ID auto button if the indicator is illuminated.
- 2 Press the rec button.**  
The rec and pause indicators illuminate, and the unit enters the record standby mode.
- 3 Press the play button to start recording.**  
The pause indicator goes out, and the play indicator illuminates.  
A program number is recorded where recording begins.
- 4 Press the play button where it is desired to record a program number during recording.**  
Each time this operation is performed, a program number (1, 2, 3 etc...) is recorded on the tape.  
If the tape is stopped temporarily with the pause button or auto rec mute button, and recording is started again by pressing the play button, a program number is recorded at that point.  
These program numbers may be checked on the program number display.

# Recording

## Note:

Please be sure to read "To Record Absolute Time" and "To Record Program Numbers" before reading this section.

## To Make Analog Recordings

First follow the procedure described in "Basic Operations for Recording and Playback" on page 12.

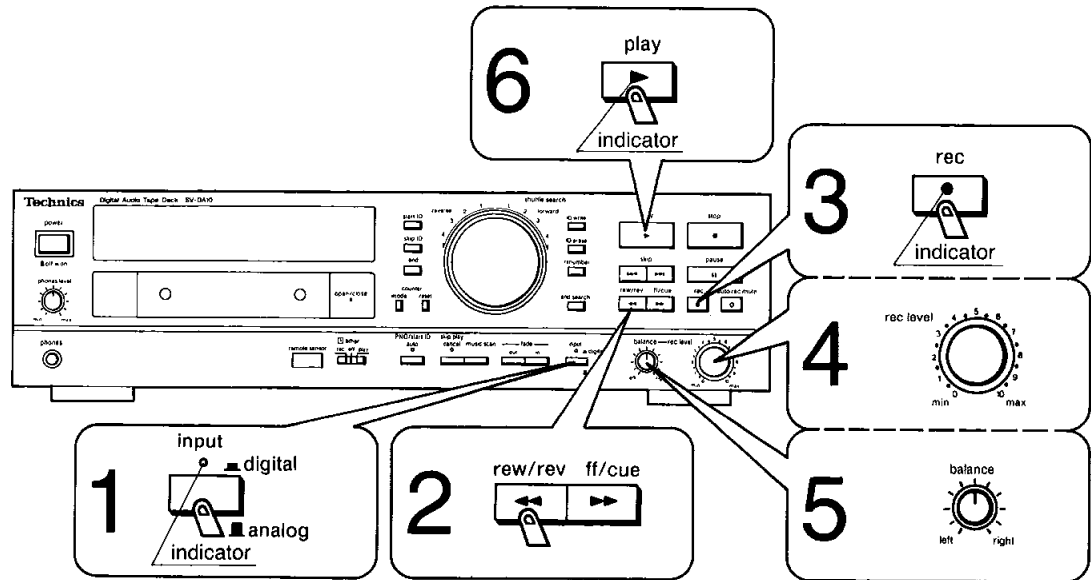

### To Record from the Beginning of the Tape

- 1 Release the input selector button.**  
The input selector indicator goes out.
- 2 Press the rew/rev button.**  
Be sure to rewind the tape even if a brand-new tape is used.
- 3 Press the rec button.**  
The rec and play indicators illuminate for approx. 4 seconds, and the pause indicator flashes (this is because the previous recording is being erased).  
The rec and pause indicators then illuminate, the play indicator goes out, and the unit enters the record standby mode.
- 4 Input the source that is to be recorded, and adjust the recording level with the rec level control. (see page 26.)**
- 5 The rec balance control should be in the center detent position.**
- 6 Press the play button.**  
The play indicator illuminates, and recording begins. The pause indicator goes out.

### To Record from the Middle of the Tape

Instead of Step 2 above, press the end search button. After the last recording position on the tape has been found, the tape will stop (end search function). Then perform Steps 3, 4, 5 and 6 as described above.

#### Notes:

- The end search function may not operate correctly for tapes which have a recording lasting only for 1 minute or so.
- If the end mark was recorded from the middle to the end when the tape was re-recorded (recording erase), end search will stop at the end mark, unlike the case when nothing has been recorded.
- In end search mode, the tape may stop at a position slightly before the last recording position.

### Note Concerning End Search

When a new recording is made on a tape and program numbers were already recorded beyond the end of the new recording, the end mark should be recorded at the end of new recording.

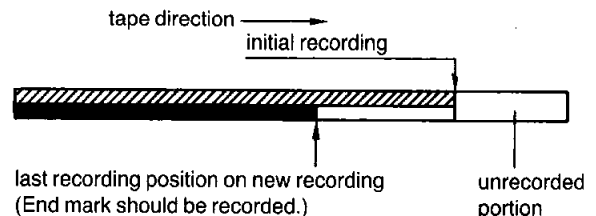



# How to Make Silent Spaces on Tape/How to Erase

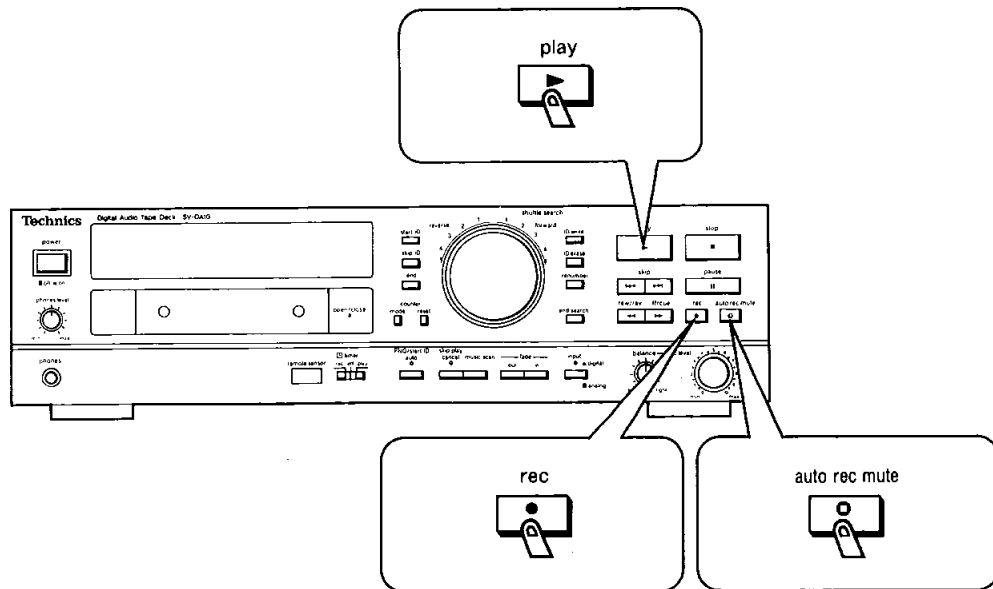

## To Make Silent Spaces on the Tape where Recording Begins

By inserting a silent space, a new recording can be clearly distinguished from the previous one.

**Press the rec button. After the unit enters the record standby mode, press the auto rec mute button.**

A silent space of approx. 4 seconds will then be recorded on the tape.

During these 4 seconds, the pause indicator will flash and the play indicator will illuminate.

## To Ensure Accurate Program Play

After a recording is finished, be sure to insert a silent space of 4 seconds before stopping or pausing the tape. Consecutive recording and program play will then be performed accurately.

## To Insert a Silent Space in a Recording (Auto Rec Mute Function)

To eliminate unnecessary commercials or noise when the needle of a record player touches the record;

**Press the auto rec mute button while the unit is in the record mode.**

A silent space of approx. 4 seconds will be automatically inserted on the tape, and the unit will then enter the record standby mode.

**To begin recording again, press the play button.**

## To Make the Silent Space Shorter or Longer

### Making It Shorter (Less than 4 Seconds)

Press the auto rec mute button, then press the pause button or play button within 4 seconds (when the pause button is pressed, the unit enters the pause mode; when the play button is pressed, recording begins).

### Making It Longer (More than 4 Seconds)

Press the auto rec mute button as long as necessary. When the button is released, the unit enters the record standby mode. To resume recording, press the play button.

## To Erase a Recorded Tape

- Reset the accidental erasure prevention tabs (see page 39) to the correct position to permit recording.
- When a tape is recorded again, any previous recording is erased automatically. To erase only the recording (without erasing absolute time), set the rec level control to the minimum position, and record up to the end of the tape (check that the peak level meter does not move).

### Note:

When end search is performed on a tape that has been erased up to the end by the above method, the unit runs to the end of the tape (although the previous recording is erased, absolute time is not, and this is viewed as a silent recording by the end search function).

## To Adjust Recording Level (for Analog Inputs)

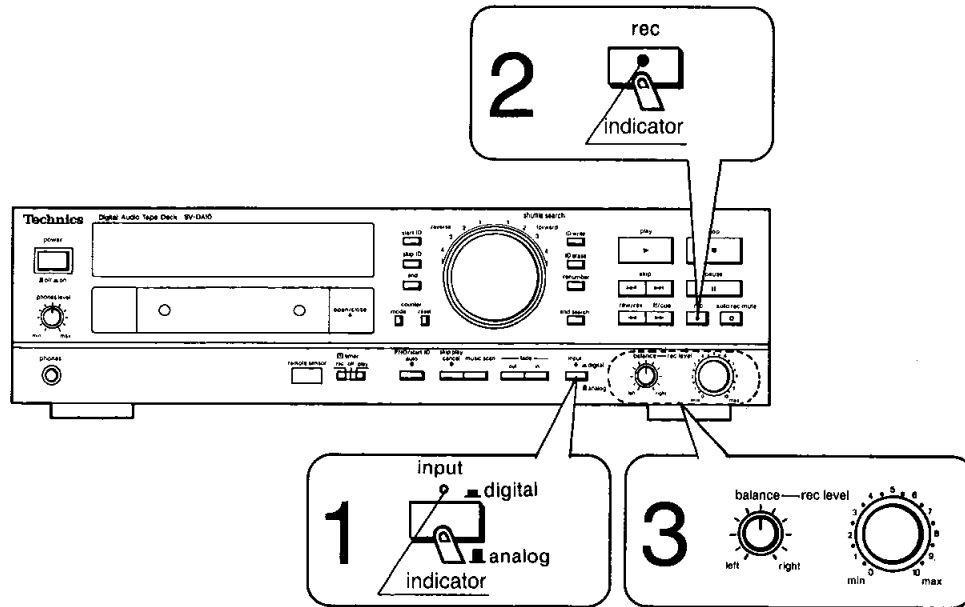

- 1 Release the input selector button.**  
The input selector indicator goes out.
- 2 Press the rec button to put the unit in the record standby mode.**  
The rec and pause indicators illuminate.

- 3 Adjust the level with the rec level control.**  
Adjust the rec level control while watching the peak level meter. Try to set the control so that average signal levels will give a meter reading around mid scale, and the loudest portions of the recording will not cause a reading higher than "0".

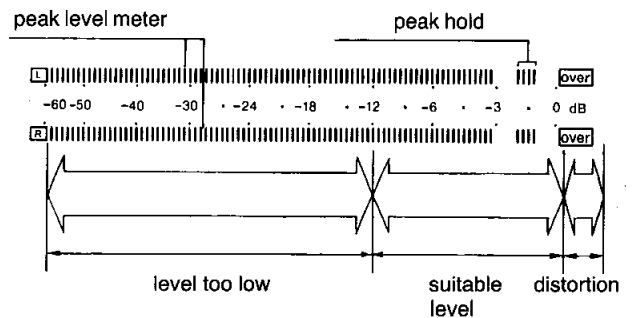

## To Make Digital Recordings (Input must be connected to digital terminals)

- First follow the procedure described in "Basic Operation for Recording and Playback" on page 12.
- Because digital recordings are made directly from digital signals, the sound obtained is equivalent to that of the original source.

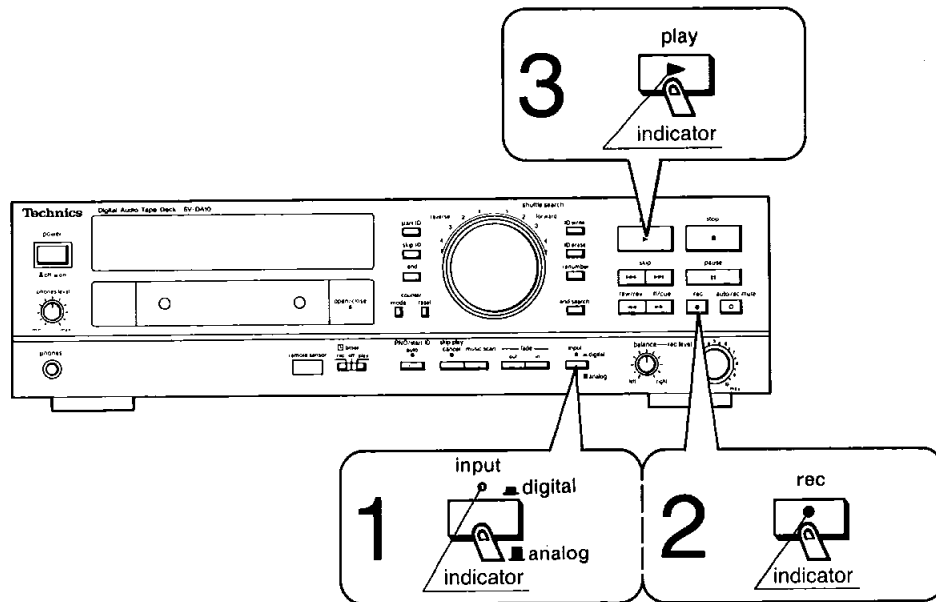

- 1 Make sure the input selector indicator is illuminated.**  
If the indicator is extinguished, press the input selector button.
- 2 Press the rec button.**  
The unit enters record standby mode (rec indicator and pause indicator illuminates.)
- 3 Press the play button.**  
The pause indicator goes out.  
The play indicator illuminates, and recording begins.
- 4 Play the digital source that is to be recorded.**  
The digital input can be monitored through the analog output or via headphones.

### Notes:

- When performing direct digital recording, it is not necessary to adjust the recording level or recording balance.
- The start IDs and skip IDs stored on the playback tape can be recorded in their original form.
- When recording is started with the program numbers displayed, it is possible to record these numbers as well.  
If the program numbers are not displayed, only the start IDs will be recorded. However, the program numbers can be added later using the renumbering function.
- The automatic program number recording mode is established when material from an old type of DAT is edited with its digital signals.
- Recording is not possible when the input indicator flashes. This flashing indicates;
  1. Connections have not been made correctly to the digital input terminals.
  2. A signal is entered on the original medium which prohibits direct digital recording.

Check your connections once again, or switch to analog input recording.

- When a burst of signal is input during digital recording, the over indicator on the peak level meter may illuminate. But this is not a malfunction.

# Digital Recording from a CD Player

Direct recording of digital signals from a CD player can be performed with this unit.

However, it is not possible to use the tape thus copied as a master tape to produce another digital copy.

This unit and your CD player can be connected directly for making digital recordings.

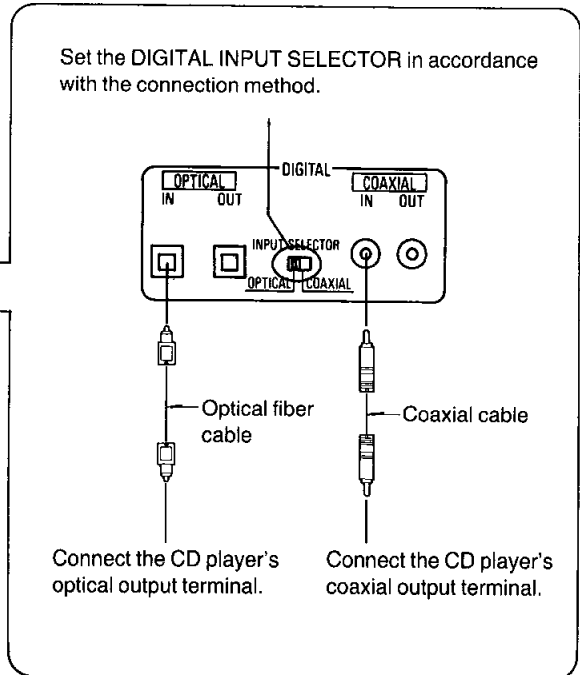
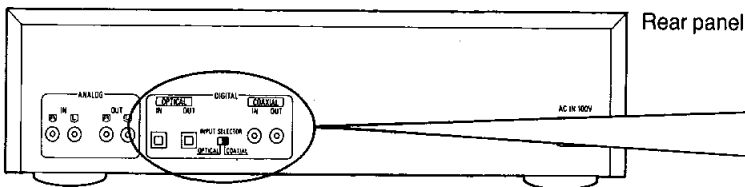

- 1 Follow the steps in recordings.
- 2 Press the play button to start recording and start playback on CD player.

**Notes:**

- When performing direct digital recording, it is not necessary to adjust the recording level or recording balance.
- Recording is not possible when the input indicator flashes. This flashing indicates:
  1. Connections have not been made correctly to the digital input terminals.
  2. A signal is entered on the original medium which prohibits direct digital recording.

Check your connections once again, or switch to analog input recording.

## From DAT to DAT (digital editing)

By connecting this unit to another DAT recorder, direct digital recording/editing can be performed from DAT music tapes. However, a digitally recorded tape cannot be used as a master for making further copies.

- Place an unrecorded DAT cassette tape in the DAT unit to be used for recording, and place the pre-recorded music tape into the playback-side DAT unit.

- 1 Follow the steps in recordings.
- 2 Set the tape on the playback-side DAT unit to the beginning of the track you wish to record.
- 3 Begin recording on the recording-side DAT unit, while simultaneously beginning playback on the playback-side unit.

**Note:**

During digital editing, if the tape on the playback side has a record-prevention signal, this part of the tape on the playback side runs forward without recording.

# To Make Fade In/Fade Out Recordings

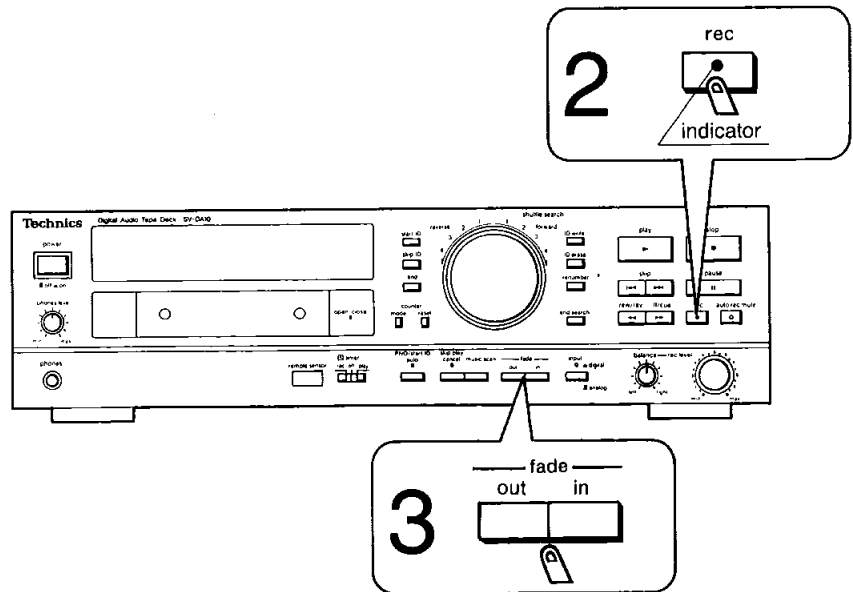

## Fade In

Fade in; start recording increasing the level of the sound gradually

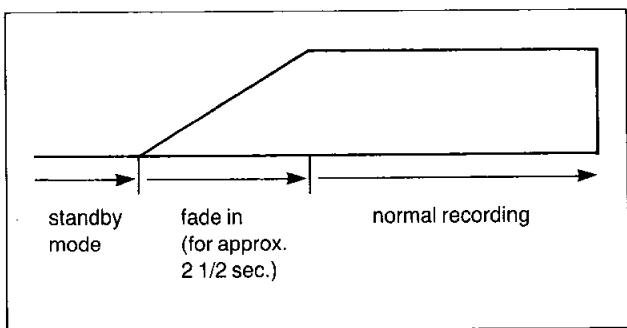

- 1** Follow the procedures described in “Before Recording” and “Recording”, according to the Source of the Sound.
- 2** Press the rec button.
- 3** Press the fade in button.  
Recording begins after approx. 2 1/2 seconds fade in.

**Note:**  
Digital signals cannot be modified by using Fade In function.

## Fade Out

Fade out; cease recording reducing the level of the sound gradually

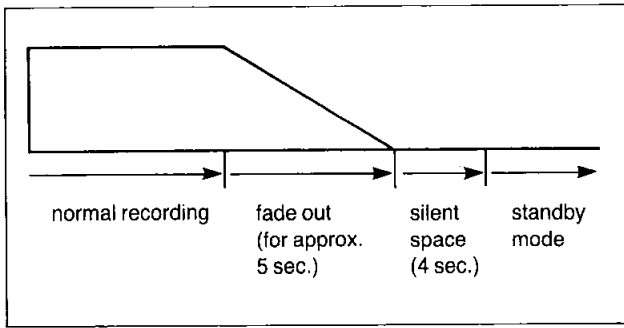

**Press the fade out button during recording.**  
After approx. 5 seconds of fade out, approx. 4 seconds silent space is recorded, and then the unit enters the record standby mode.

**Note:**  
Digital signals cannot be modified by using Fade Out function.

# Indexing (Procedure to be followed during playback).

Indexing allows certain DAT subcode information, excluding end mark, to be recorded without affecting any audio material that already exists on the tape.

The following subcodes are available with this unit;

- start ID; indicating the beginning of the program
- skip ID; causing the unit to go into fast-forward mode until the next start ID is reached, in order to skip unwanted material
- end mark; indicating the end of the last recording on the tape
- program number (PNO); the number of the program recorded on tape
- absolute time; the elapsed time from the beginning of the tape
- program time; the elapsed time from the beginning of a program
- table of contents (TOC, for read only); Used to display the total number of programs and total playing time by TOC data recorded on commercially produced media

1. A start ID can be recorded at the beginning of any tune or between tunes as desired.  
The start ID can be recorded by choosing either a 1) automatic, or 2) manual mode.
2. Recorded start ID's can be automatically recalculated and assigned a set of sequential numbers.
3. Skip ID's can be recorded to automatically skip over parts of the tape you do not wish to hear.
4. Recorded start ID's and skip ID's can be erased.
5. End mark can be recorded at the end of the recording.

## Notes:

- Reset the accidental erasure prevention tabs so that the tape can be recorded.
- To index the tape in the stop or pause mode, advance the tape to the desired position by means of the shuttle search dial, ff/cue button or rew/rev button, and then stop it with the pause or stop button.  
If indexing is carried out from the stop mode, the tape will be in the stop mode after indexing.

## Recording and Erasure of start ID/skip ID/end mark

During recording, start ID, program number, absolute time and program time can be recorded automatically by setting the PNO/start ID auto button. Program numbers can be corrected by indexing. By recording start ID's and skip ID's, the desired tape can be made for playback.

### Start ID

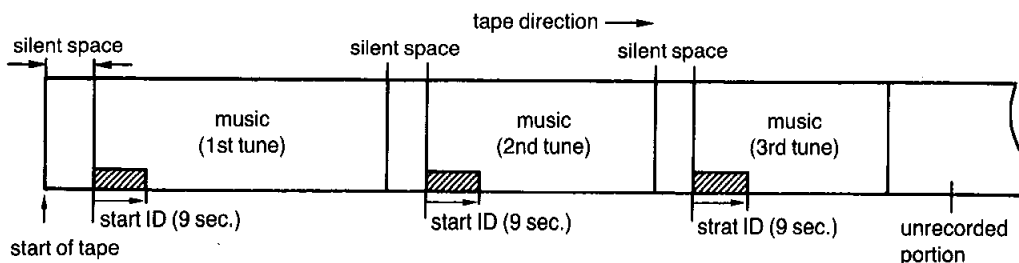

1. Program number is recorded in the tune's order.
2. Start ID can be manually recorded at your desired position.
3. Start ID can be searched by using search function and also erased.
4. After editing start ID's, program number can be rearranged in start ID order.

### Skip ID/End mark

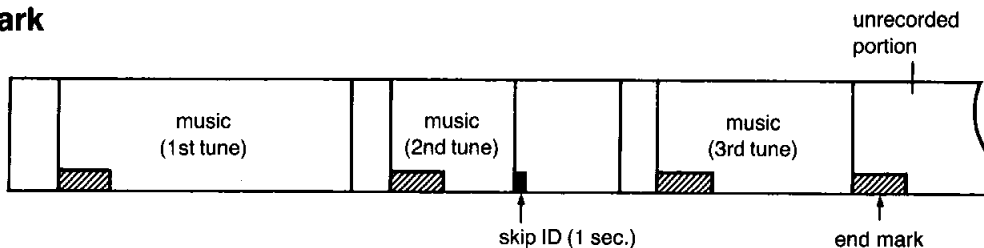

1. Skip ID can be manually recorded at your desired position.
2. Skip ID can be erased.
3. End mark can be recorded at the end of the recording. The continue recording is available by using end search function.
4. End mark can be searched by using end search function and erased.

## To Record Start ID's (During Playback)

### Automatic Recording

In this mode, a start ID is automatically recorded at the beginning of each tune, as the unit detects the starting point of each music passage. In the case of where tapes already have start ID's, the previous start ID is erased and a new start ID is recorded where the sound begins. As long as these start ID's are recorded, you will be able to make full use of access play and program play functions.

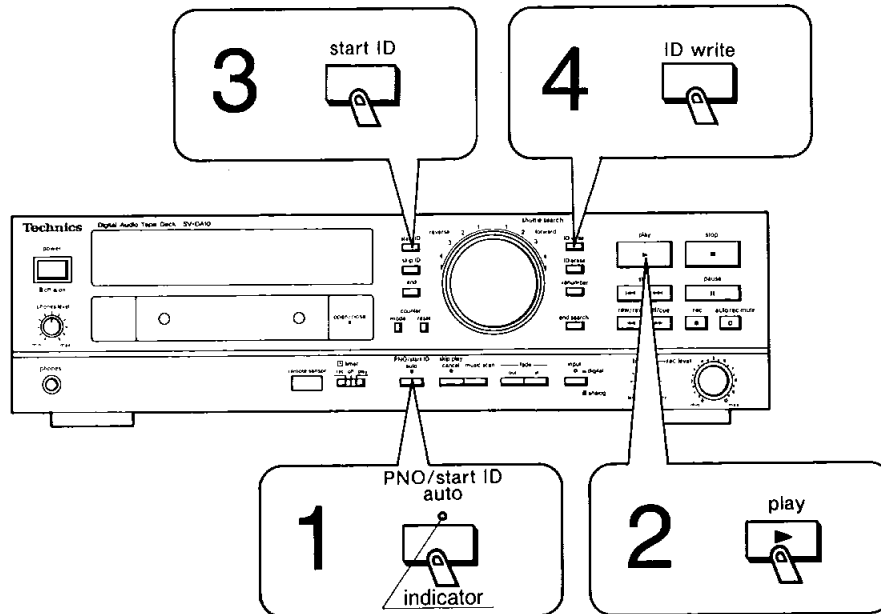

#### 1 The "AUTO" mode is selected automatically at power-up.

Press the PNO/start ID auto button if the PNO/start ID auto indicator is not illuminated.

#### 2 Press the play button.

#### 3 Press the start ID button.

The [start ID] indicator will flash.

#### 4 Press the ID write button.

When the beginning of a program is found, the start ID indicator stops flashing for about 9 seconds during which time the start ID is being recorded.

Subsequent start ID's will automatically be recorded as playback progresses.

Note that the absolute time will also be recorded as well.

#### Notes:

1. Automatic start ID recording progresses from wherever playback is started. Be sure to rewind the tape if this function is to start from the beginning of the tape.
2. While in the automatic start ID recording mode, most function keys such as "skip", "rewind", etc. will not function. This is normal as to prevent any miscounting.

## To Cancel the Auto Mode

#### 1 Press the stop button.

The indexing function will be released.

#### 2 Press the PNO/start ID auto button.

The PNO/start ID auto indicator will go out.

#### Note:

If the open/close button is pressed and the cassette tape is removed during indexing, the index mode will be cancelled.

## Manual Recording

In this mode, start ID's can be recorded manually, at any desired point on the tape.

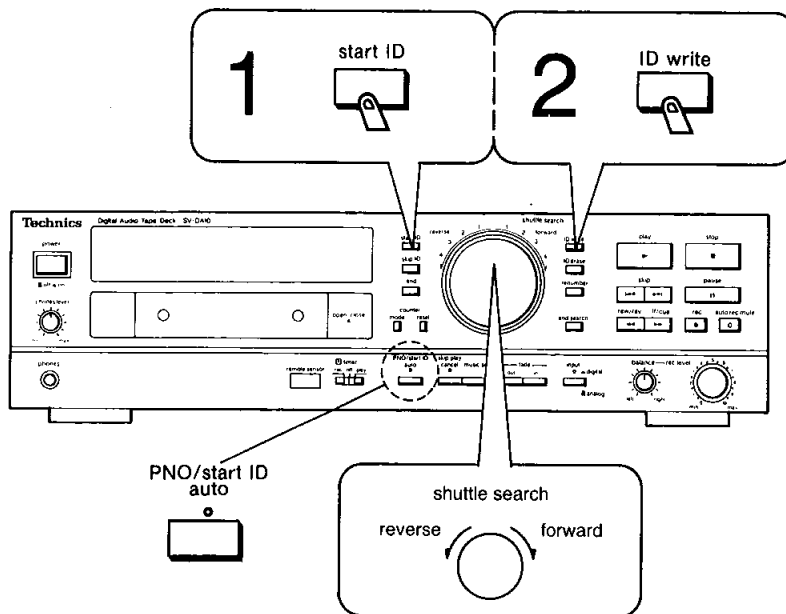

Check the PNO/start ID auto indicator is not illuminated. If it is, press the PNO/start ID auto button to cancel it.

- 1 Press the start ID button.**  
The **start ID** indicator will flash.
- 2 While listening to the playback sound, advance or rewind the tape using the shuttle search. Then, at the point where you want to insert a start ID, press the ID write button.**  
The **start ID** indicator stops flashing for about 9 seconds and then starts flashing again. A start ID (approx. 9 sec.) will be recorded at the point where the button was pressed. Then the unit is ready for inserting the next start ID.
- 3 Repeat Step 2 to insert subsequent start ID's one after another wherever desired.**

### Note:

Do not press the stop button when the **start ID** indicator is illuminated (approx. 9 sec.), in both Automatic/Manual Recording. If the stop button is pressed, the start ID will not be recorded long enough to be detected.

## Shuttle Search

This function allows you to search rapidly forward or backward on the tape for specific sections with a high degree of accuracy while listening to the materials recorded on the tape.

### Approximate search play speed (four steps)

Scale	Operation mode	Play	Pause
	1		×3
2		×5	×1
3		×9	×2
4		×15	×3



## To Assign Sequential Numbers to Recorded Start ID's

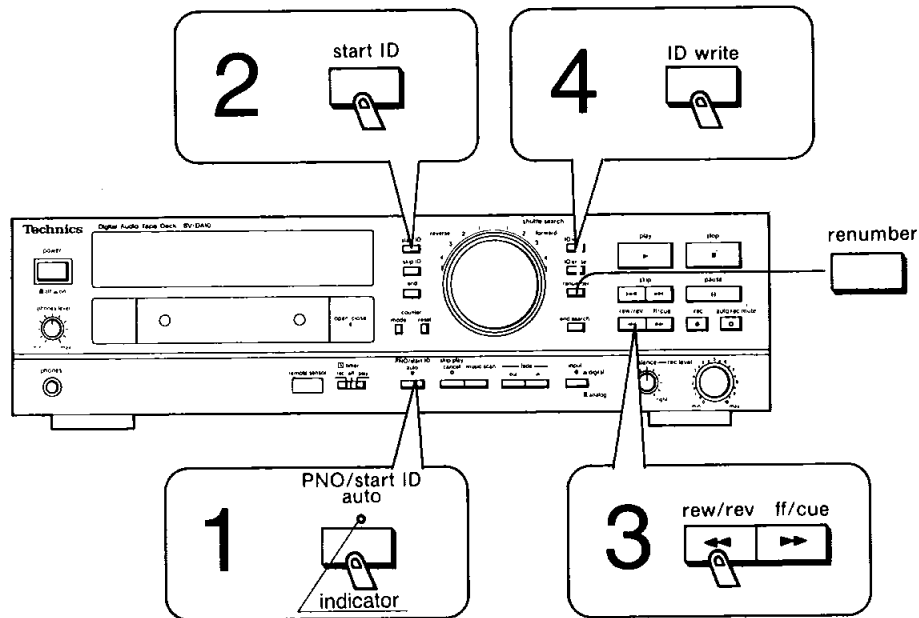

### After recording of start ID's, press the renumber button.

The tape will rewind to the beginning, the unit searches for the recorded start ID's, and assigns program numbers to them in sequence starting from 01. When the tape reaches the end, the renumber function is complete, and the tape is rewound to the beginning again (auto rewind function).

While the tape is running, the play indicator flashes.

Each time the tape comes to a position where a start ID has been recorded, the **start ID** indicator illuminates.

### To Record Absolute Time with the Index Function

Even on tapes where absolute time has not been recorded, it can be recorded while indexing is being carried out.

- 1 Enter the "AUTO" mode.**  
Press the PNO/start ID auto button if the PNO/start ID auto indicator is not illuminated.
- 2 Press the start ID button to put the unit in the automatic program number recording mode.**  
The **start ID** indicator will flash.
- 3 Press the rew/rev button to rewind the tape to the beginning.**
- 4 Press the ID write button.**  
Start ID's will be recorded on the tape automatically, together with absolute time.

#### Note:

If program numbers, start ID's skip ID's, and end mark have been recorded in any part of the tape, they are all erased during a new recording.

## To Erase Recorded Start ID's (During Playback)

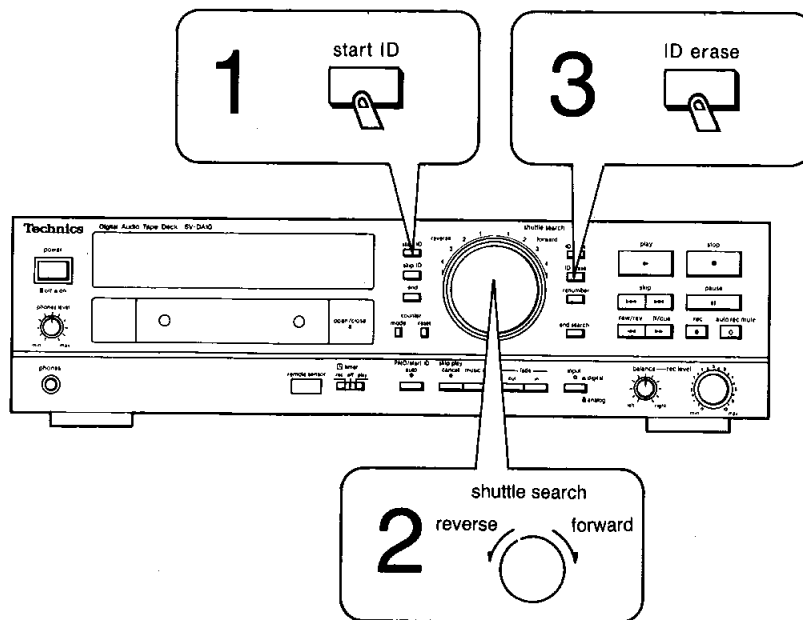

- 1 Press the start ID button.**  
The **start ID** indicator flashes.
- 2 Turn the shuttle search dial to run the tape to the approximate beginning of the start ID.**  
When the tape comes to a position where a start ID was recorded, the **start ID** indicator illuminates to show there is a start ID at that position.  
For convenience, the beginning of the current program's start ID can also be found and erased automatically by simply pressing the ID erase button.
- 3 Press the ID erase button.**  
The **erase** indicator illuminates.  
The tape is then rewound to find the start ID and erasure begins just before the beginning of the start ID, (during this time, the **erase** indicator illuminates, and the **start ID** indicator flashes). After erasure, the **erase** indicator goes out, and playback continues.
- 4 Repeat Step 2~3 to erase subsequent ID's, if necessary.**

## To Record or to Erase the End Mark

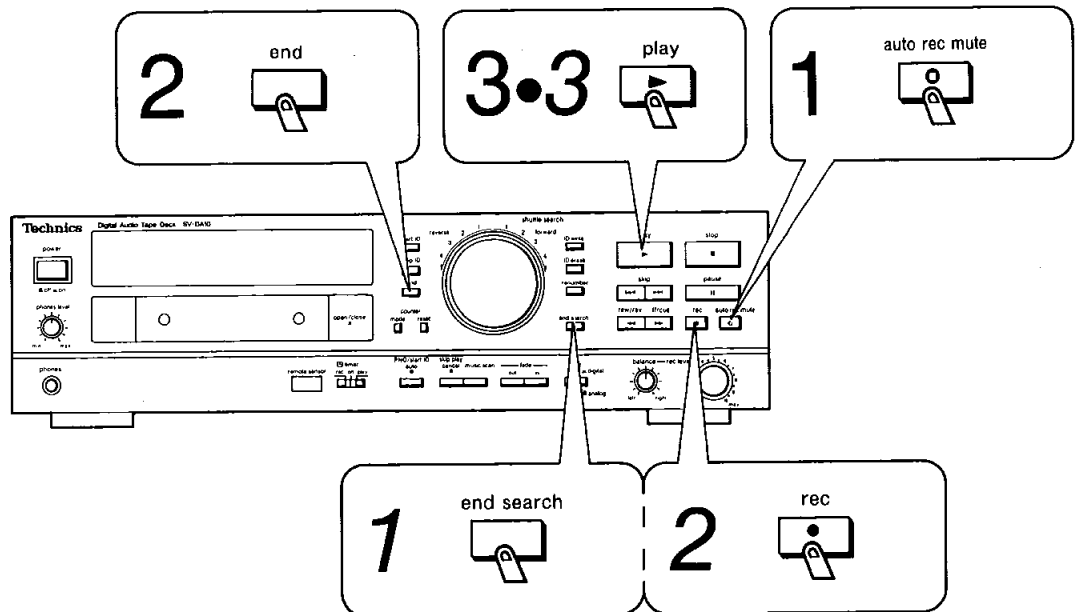

### To Record the End Mark

- 1 After recording (in recording standby mode), press the auto rec mute key.**  
After approx. 4 seconds silent space will be recorded, and the unit enters the recording standby mode.
- 2 Press the end button.**  
The **end** indicator flashes.
- 3 Press the play button.**  
The **end** indicator lights.

While the end mark is being recorded (for approx. 9 seconds), "EE" appears on the program number display.  
Recorded music data on the end mark is erased.

After the end mark is recorded, the tape is rewound at the beginning of the end mark, and the unit enters the stop mode.

Indexing mode of the end mark will be released automatically.

### To Erase the End Mark

- 1 Press the end search button.**  
After the tape is rewound to the beginning automatically, the end mark will be searched, and the unit enters the stop mode.
- 2 Press the rec button.**  
The rec and pause indicators illuminate.
- 3 Press the play button.**  
Recording starts and the end mark will be erased.

During the normal recording, the end mark will be automatically erased, so that recording can be continued.

# Timer Recording/Playback

If an audio timer (not included) is connected to this unit, recording of a radio broadcast, or tape playback, will automatically begin at the preset time. Timer recording or playback is also possible by using a tuner with timer. Connect the AC power cord of this unit to the power source outlet of the timer. (See the operating instructions of the timer for detailed information.)

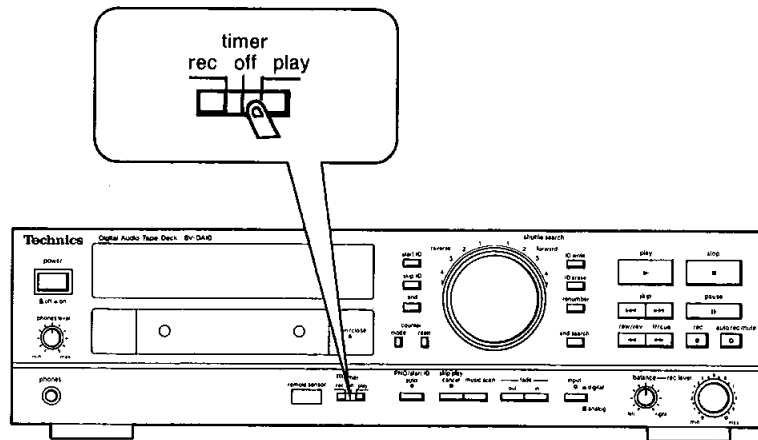

## Timer recording

- 1 Prepare for recording.**  
After adjusting the recording level, press the stop button.
- 2 Set the timer to the desired recording-start time.**  
(Power switch will come off.)
- 3 Set the timer switch to the “rec” position.**  
(At the set time, the power switch will come on and the audio source will be recorded.)

### ■ After setting the timer

Check to be sure that the power switch is set to the “on” position.

## Timer playback

- 1 Rewind the tape to the position from which you want playback to begin.**
- 2 Set the timer to the desired playback-start time.**  
(Power switch will come off.)
- 3 Set the timer switch to the “play” position.**  
(At the set time, the power switch will come on and the playback will begin.)

### ■ After setting the timer

Check to be sure that the power switch is set to the “on” position.

# Operation Notes

## Condensation

In winter, moisture droplets may form on the window panes of a heated room. This phenomenon is called condensation. Condensation may occur with this unit or with cassette tape in the following situations:

- In a room where a heater has just been turned on
- In a room where steam or excessive moisture are present
- When the unit is brought in suddenly from a cold place to a warm room
- When the unit is directly in the path of cold air from an air conditioner, etc.

In such cases, the unit will not operate correctly, and even if it does operate, the tape may be damaged.

In particular, if moisture condenses on the rotating heads, the tape will stick. This will prevent the tape from running properly, and might damage it.

## If Condensation Occurs

To protect the tape, this unit contains a built-in device so that when condensation occurs, the  dew indicator on the display panel flashes. While the  dew indicator is flashing, apart from the OPEN/CLOSE function, buttons on the unit will not operate.

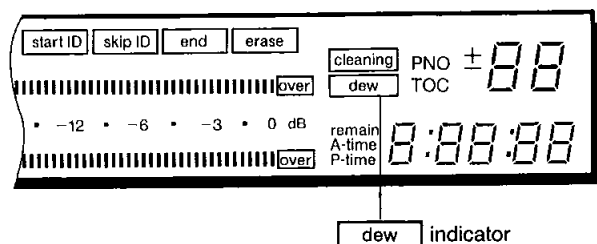

If a cassette tape is loaded in the unit, remove it and leave the power switched on. Wait until the indicator goes out. The time required for moisture to evaporate will vary according to the environment, but it may be 60 minutes or longer if humidity is high. Condensation usually sets in gradually, so the indicator may not flash for the first 10~15 minutes. If room temperature or humidity changes abruptly, therefore, wait for about 20 minutes before switching on the power to check that the indicator is not flashing.

## Unloading Function

If 2 hours time elapses when the unit is in the stop, pause or record standby modes, the cassette tape will be released automatically from the rotating mechanism.

## Operating the Unit

### ■ Always keep the cassette holder closed.

If it is left open, dust will accumulate in the mechanism and cause tape playback or recording performance to deteriorate. Do not touch the inside of the cassette holder.

### ■ If the unit is not used for extended periods, remove the cassette tape.

### ■ The top of the deck will become hot during use, but this is perfectly normal.

### ■ Keep the volume of the amplifier low.

With DAT (Digital Audio Taperecorder) cassettes, there is much less noise than with compact cassettes and a wider dynamic range.

There will be a sudden burst of sound when the music starts, and as this may damage the speakers, due care should be taken. Be especially careful when using headphones.

### ※Dynamic Range

Dynamic range means the difference between the lowest sound level and highest sound level, and is expressed in decibels (dB). The greater this difference, the more dynamic the recording.

### ■ When carrying or storing the unit, take care not to subject it to any severe shocks.

When storing or transporting the unit, be sure also to remove the cassette tape.

## Recording of Program Numbers

- In automatic or manual recording of program numbers, a start ID of 9 seconds duration is recorded each time a program number is recorded.
- Some compact discs have a very short interval between tunes. Even in these cases, however, if your CD player has an auto space function, the space between tunes can be set automatically so that program numbers are entered correctly during recording.

# Maintenance

To clean this unit, use a soft, dry cloth. If the surfaces are extremely dirty, use a soft cloth, dipped into a soap-and-water solution or a weak detergent solution. Wring the cloth well before wiping the unit. Wipe once again with a soft, dry cloth.

Never use alcohol, paint thinner, benzine, nor a chemically treated cloth to clean this unit.

Such chemicals may damage the finish of your unit.

# About DAT Cassette Tape

## About DAT Cassette Tape

DAT tape can be recorded and played on only one side. DAT cassette tapes, unlike compact cassettes, are completely sealed. Also, the tape and hub holes are protected by a top lid and slider.

The cassette is so designed that, apart from when it is loaded, dust or foreign particles cannot enter the cassette housing to cause dropout (digital signal losses). Dropout is the main reason for the impairment of quality in digital recording.

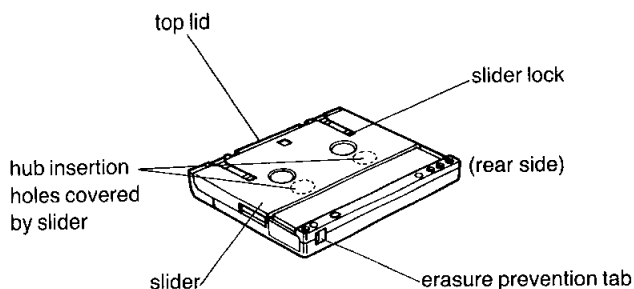

## Handling DAT Cassette Tapes

- Moisture may condense on a tape which is carried suddenly from a cold place into a warm room, so wait about 20 minutes before using it.  
If the tape is used with moisture on its surface, it will be damaged.
- Do not attempt to dry a cassette tape with moisture on its surface by using a hair dryer or other appliance.
- Do not open the top lid of the cassette, pull the tape out or touch it.
- Take care not to drop the cassette, hit it or subject it to violent vibration.
- The cassette mechanism has been assembled very precisely. It should on no account be disassembled.
- The cassette cannot be used on the reverse side.

## Storing DAT cassette Tapes

- Store the cassette in its case to prevent the entry of dust.
- Do not leave or store the cassette in the following locations:
  1. Near objects with strong magnetic fields (speakers, televisions, transformers, motors or magnets).
  2. Places with excessive humidity (over about 80%) or dust.
  3. Places with high temperatures (over about 35°C).
  4. Places exposed to direct sunlight or heat from heating appliances.  
The cassette should never be left in a car dashboard or near the rear window.
- 5. After use, rewind the tape to the beginning. If rewinding is interrupted, it may lead to creases in the tape and affect sound quality on playback.

## Using DAT Cassette Tapes

•**To avoid accidental erasure of valuable recordings**  
Recorded tapes you want to keep can be protected by sliding the "accidental erasure prevention tab" open towards the center of the cassette with the aid of a small screwdriver as in the diagram. It will then be impossible to record on the tape, and valuable recordings will not be erased by accident.

### •Method of using accidental erasure prevention tab

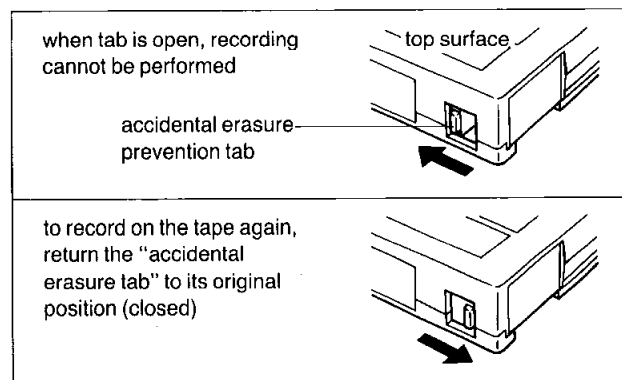

## Cassette Tapes with no Accidental Erasure Prevention Tab

Break open the hole with a small Philips screwdriver or other tool.

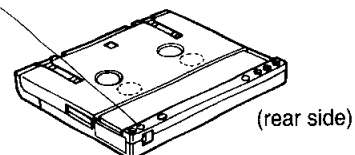

With this method, however, the tape cannot be returned to its original condition, and it cannot therefore be recorded again.

# Troubleshooting Guide

Before requesting service for this unit, check the chart below for a possible cause of the problem you are experiencing. Some simple checks or a minor adjustment on your part may eliminate the problem and restore proper operation. If you are in doubt about some of the check points, or if the remedies indicated in the chart do not solve the problem, refer to the directory of Authorized Service Centers (enclosed with this unit) to locate a convenient service center, or consult your dealer for instructions.

Fault	Main Cause	Remedy
Unit does not record or play cassettes even though power is switched on.	<ul style="list-style-type: none"> <li>•There is condensation inside unit.</li> </ul>	<ul style="list-style-type: none"> <li>•Wait until the <span style="border: 1px solid black; padding: 0 2px;">dew</span> indicator goes out.</li> </ul>
Cassette holder does not close when a cassette tape is loaded even if the open/close button is pressed.	<ul style="list-style-type: none"> <li>•Cassette tape is not properly loaded.</li> </ul>	<ul style="list-style-type: none"> <li>•Load the cassette tape in the proper direction.</li> </ul>
No sound is output although the tape is running.	<ul style="list-style-type: none"> <li>•Volume control on stereo amplifier is set at minimum.</li> </ul>	<ul style="list-style-type: none"> <li>•Adjust volume using amplifier volume control.</li> </ul>
	<ul style="list-style-type: none"> <li>•Stereo amplifier selector is set at a position other than "DAT" or "TAPE".</li> </ul>	<ul style="list-style-type: none"> <li>•Set the input selector position to either "DAT" or "TAPE" depending on the connections to the unit.</li> </ul>
Noise or distortion is heard during playback.	<ul style="list-style-type: none"> <li>•Recording level was too high or too low.</li> </ul>	<ul style="list-style-type: none"> <li>•Record the tape again at the optimum level.</li> </ul>
	<ul style="list-style-type: none"> <li>•Heads are dirty.</li> <li>•Cassette tape is worn out.</li> </ul>	<ul style="list-style-type: none"> <li>•Clean the heads with a special DAT cleaning tape and record the tape again.</li> <li>•Use a new cassette tape.</li> </ul>
Analog recording cannot be performed.	<ul style="list-style-type: none"> <li>•Erasure prevention tab on cassette tape is open.</li> </ul>	<ul style="list-style-type: none"> <li>•Close the erasure prevention tab.</li> </ul>
	<ul style="list-style-type: none"> <li>•Unit is not connected properly to the stereo amplifier.</li> </ul>	<ul style="list-style-type: none"> <li>•Connect the unit properly.</li> </ul>
	<ul style="list-style-type: none"> <li>•Recording level control is set at "0".</li> </ul>	<ul style="list-style-type: none"> <li>•Adjust recording (input) level with recording level control.</li> </ul>
	<ul style="list-style-type: none"> <li>•Input indicator is illuminated.</li> </ul>	<ul style="list-style-type: none"> <li>•Press the input selector button.</li> </ul>
Indexing cannot be performed.	<ul style="list-style-type: none"> <li>•Erasure prevention tab on cassette tape is open.</li> </ul>	<ul style="list-style-type: none"> <li>•Close the erasure prevention tab.</li> </ul>
Auto skip play cannot be performed.	<ul style="list-style-type: none"> <li>•Skip play cancel indicator is illuminated.</li> </ul>	<ul style="list-style-type: none"> <li>•Press skip play cancel button to turn off the indicator.</li> </ul>
Digital signals cannot be recorded.	<ul style="list-style-type: none"> <li>•Input selector indicator goes out.</li> </ul>	<ul style="list-style-type: none"> <li>•Press the input selector button.</li> </ul>
	<ul style="list-style-type: none"> <li>•Digital input/output connections on rear of unit are not correct.</li> </ul>	<ul style="list-style-type: none"> <li>•Make proper digital input/output connections.</li> </ul>
	<ul style="list-style-type: none"> <li>•Signals to prohibit digital recordings are input on to the tape.</li> </ul>	<ul style="list-style-type: none"> <li>•Switch to analog input recording.</li> </ul>
Search function does not operate properly.	<ul style="list-style-type: none"> <li>•Start ID has not been recorded properly.</li> </ul>	<ul style="list-style-type: none"> <li>•Record the start ID, using the auto ID function.</li> </ul>
Program time is not displayed properly.	<ul style="list-style-type: none"> <li>•Program numbers have not been recorded properly.</li> </ul>	<ul style="list-style-type: none"> <li>•Add serial numbers to recorded start IDs.</li> </ul>
	<ul style="list-style-type: none"> <li>•Cassette tape has been inserted midway through a program.</li> </ul>	<ul style="list-style-type: none"> <li>•Press rewind button and rewind to start of program.</li> </ul>
Unit does not playback, record or operate properly.	<ul style="list-style-type: none"> <li>•Unit was not operated in accordance with instructions.</li> </ul>	<ul style="list-style-type: none"> <li>•Switch off power, and operate again correctly in accordance with instructions.</li> </ul>



# Technical Information 1

## SCMS (Serial Copy Management System)

This unit is equipped with SCMS (Serial Copy Management System). SCMS is a system which allows digital-signal copy of CDs and commercial music DAT cassettes only for one "generation". The DAT cassette thus recorded cannot be used as a master tape to produce further generations (serial copies) of the first digital copy.

The accompanying illustrations describe the ways in which recording is possible from each kind of source.

### 1 DAT cassettes recorded digitally from CDs

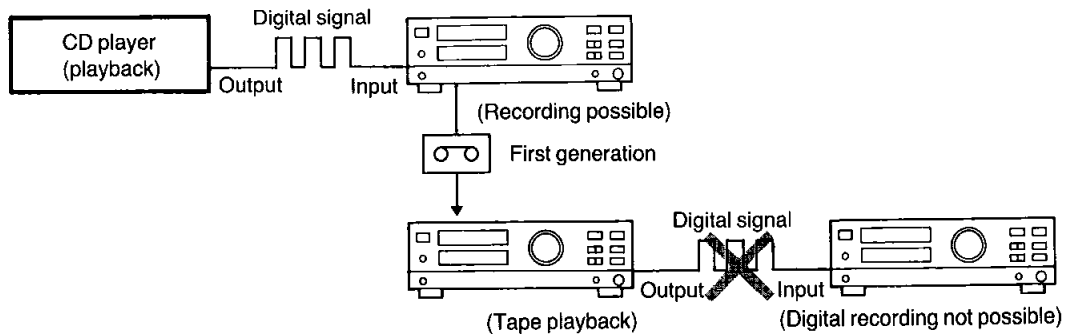

Digital-signal recording from a CD can be performed only for the first generation of DAT cassette. The DAT cassette thus recorded (1st generation) cannot be used as a master to make further digital copies (serial copies).

### 2 DAT cassettes recorded digitally from a commercially produced music DAT cassette

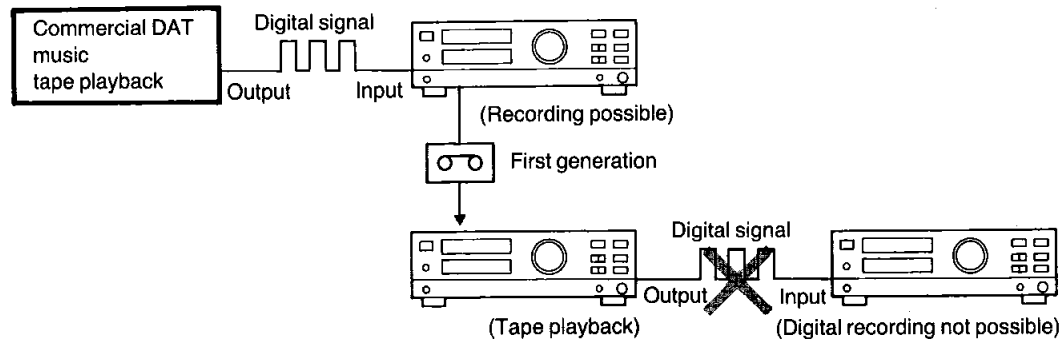

Digital-signal recording from a commercially produced DAT music cassette can be performed only for the first generation of DAT cassette. The DAT cassette thus recorded (1st generation) cannot be used as a master to make further digital copies (serial copies). However, it should be noted that it may not be possible to make digital copies from commercial DAT music tapes which do not conform to the SCMS format.

**3** DAT cassettes recorded from analog input terminals (when thereafter recorded digitally)

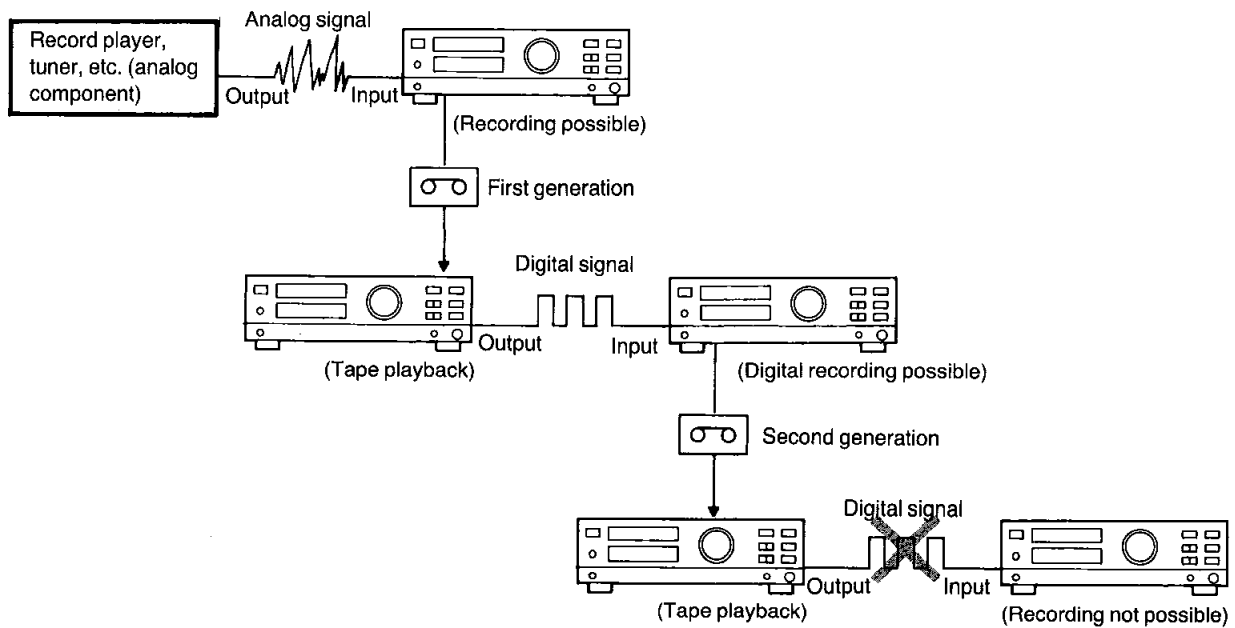

When the DAT recording of an analog source is used as the master tape for further digital-signal DAT copies, up to two generations of digital copies can be made. However, the second generation of such copies cannot be used as the master tape for making third and subsequent generations of digital copies (serial copies).

**4** DAT cassettes recorded from analog input terminals (when recorded in analog thereafter)

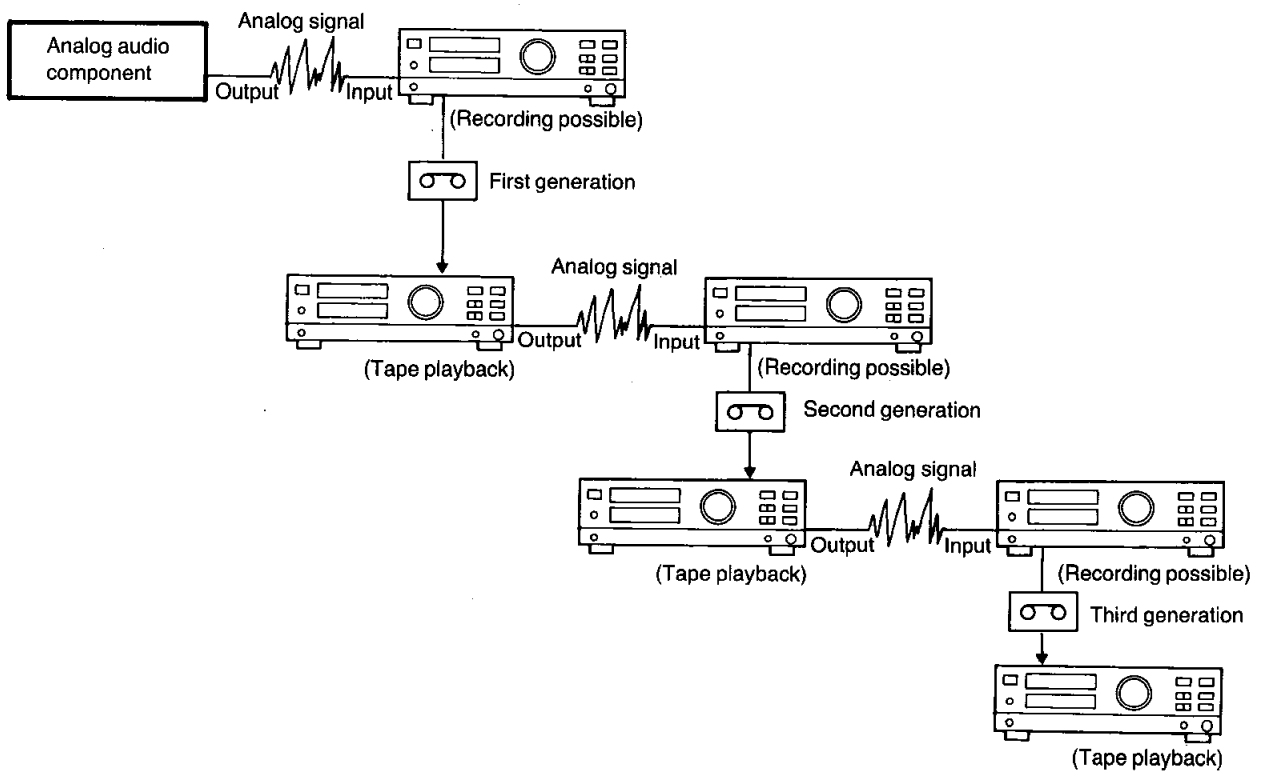

When recording is performed from the analog input terminals, no restrictions are made on copies, in the same way as for conventional audio cassette tape recorders and previous DAT decks. Accordingly, even in cases where recording of the digital signal (digital copy) is not possible, the analog input and output terminals can be used to perform analog recording.

NOTE: It may not be possible to make digital recordings from DAT decks which do not conform to the SCMS format.

# Technical Information 2

## MASH Type 1-bit ADC/DAC

### 1. Features

In order to realize the ultimate in AD and DA conversion throughout all frequency ranges, this unit has been equipped with the revolutionary ADC/DAC unit which adopts "noise-shaping" and over-sampling technologies.

The MASH-type 1-bit ADC/DAC unit uses a single reference level, thus in principle eliminating any non-linear distortion or zero-cross distortion, and thus producing superb linearity across the range from large to minute signal inputs. Further, the analog circuits connected before and behind the ADC/DAC unit makes unnecessary the sample/hold circuits, de-glitcher circuit used in previous applications, and also make it possible to use a simpler low-pass filter, thus allowing accurate recording and playback reproduction even of minute signal inputs. This eliminates the "hard edge" often associated with previous digital media, allowing you to enjoy a softer sound closer to the analog original.

### 2. Construction

Figure 1 shows a block diagram of the MASH-type 1-bit ADC unit. The input analog signal is quantized at a 64 times oversampling by the MASH quantization circuit, and transformed to 4-bit digital data after which it is filtered by the digital filter, and output as 16-bit digital data with the normal sampling frequency.

Fig. 2 is a block diagram of the MASH-type 1-bit DAC unit. The 16-bit input digital data passes through the digital filter section where it is 4 times sampled and transformed into 18-bit data. Next, the MASH quantizing circuit provides tertiary noise shaping to yield 32 fs 8-level data which is then transformed by the PWM 1-bit DAC section into pulse-width-modulated (PWM) waveforms, and output. The output is a 1-bit data with "low" and "high" states only.

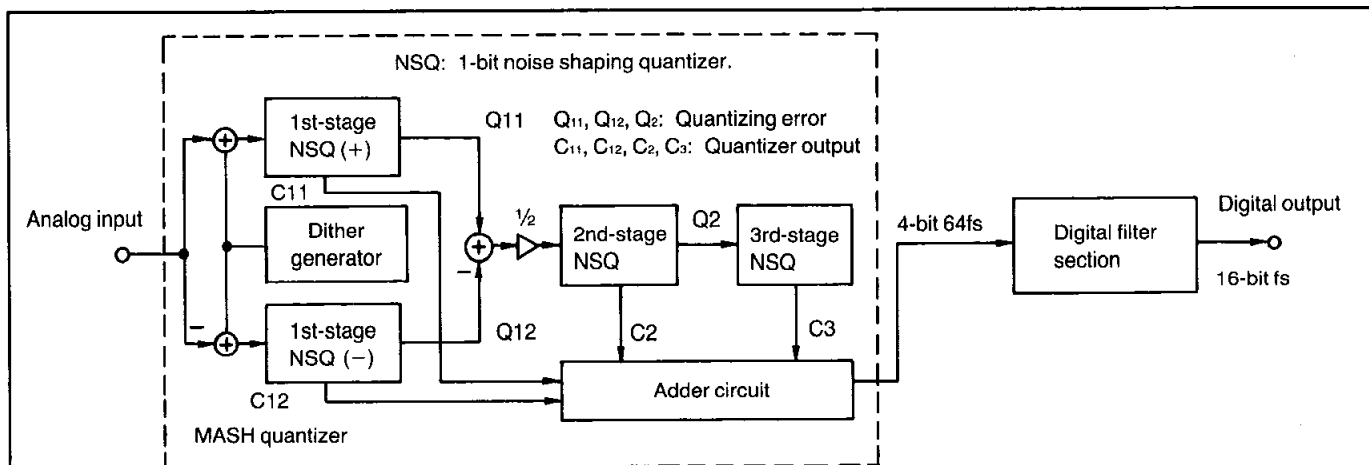

Figure 1. MASH-type 1-bit ADC block diagram

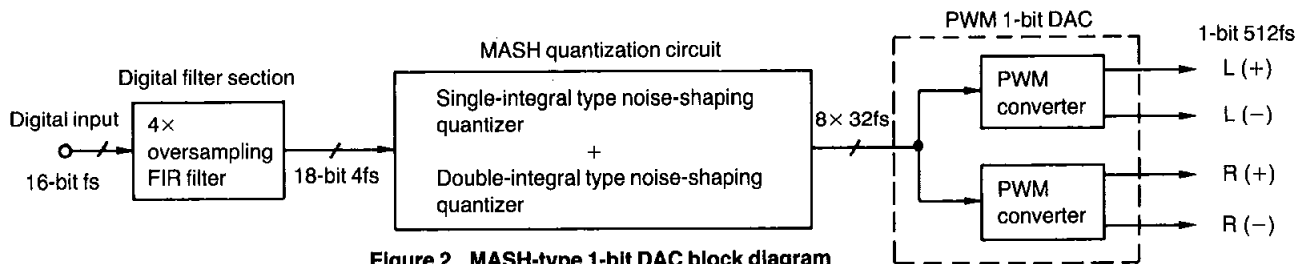

Figure 2. MASH-type 1-bit DAC block diagram

# Technical Specifications

## ■ Signaling Format

**Tape recording system:** Rotary head type DAT  
**Sampling frequencies:**  
  **For recording;** 48 kHz/44.1 kHz  
                  32 kHz (automatically selected during  
                  digital recording)  
  **For playback;** 48 kHz/44.1 kHz/32 kHz  
                  (selected automatically)  
**No. of quantizing bits:** 16-bit linear  
**No. of channels:** 2 (stereo)

## ■ Audio Parameters (Digital recording/playback)

**Frequency response:** 2 Hz~22,000 Hz  
                          (Sampling frequency 48 kHz)  
                          2 Hz~20,000 Hz  
                          (Sampling frequency 44.1 kHz)  
                          2 Hz~15,000 Hz  
                          (Sampling frequency 32 kHz)  
**Dynamic range:** Greater than 95 dB (IHF'A weighted)  
**Signal to noise ratio:** Greater than 107 dB (IHF'A weighted)  
**Total harmonic distortion:** Less than 0.003% (1 kHz)  
**Wow and flutter:** Unmeasurable

## (Analog recording/playback)

**Frequency response:** 2 Hz~22,000 Hz ( $\pm 0.5$  dB)  
**Dynamic range:** Greater than 90 dB (IHF'A weighted)  
**Signal to noise ratio:** Greater than 90 dB (IHF'A weighted)  
**Total harmonic distortion:** Less than 0.007% (1 kHz)  
**Wow and flutter:** Unmeasurable

## ■ Input/Output Jacks

**Analog Input jacks**  
  **Minimum input level:** 140 mV (-12 dB rec level)  
  **Input impedance:** 47 k $\Omega$   
**Analog output jacks**  
  **Full-scale output level:** 2 V  
  **Output impedance:** 600 $\Omega$   
**Phones output:** Max. 30 mW+30 mW/32 $\Omega$   
                  (Matching impedance 8~600 $\Omega$ )  
**Digital input jacks:** Coaxial/75 $\Omega$ , Optical  
                          (with selector switch)  
**Digital output jacks:** Coaxial/75 $\Omega$ , Optical  
                          (parallel output)

## ■ Mechanism

**Heads:** Amorphous ferrite composite type  
**Cylinder diameter:** 30 mm  
**Cylinder rotation speed:** 2000 r.p.m.  
                                  (recording and playback)  
**Tape speed:** 8.15 mm/sec., 12.225 mm/sec.  
                                  (selected automatically)  
**Search speed:** Up to 400 times normal playback speed  
**FF/Rewind time:** Approx. 27 sec. (2 hours DAT tape)

## ■ General

**Power supply:** AC 50 Hz/60 Hz, 240 V  
**Power consumption:** 27 W  
**External dimensions  
(W×H×D):** 43×12.2×33.9 cm  
                                  (17"×4 $\frac{3}{4}$ "×13 $\frac{5}{16}$ ")  
**Weight:** 5.7 kg (12 $\frac{1}{2}$  pounds)

---

**Note:**  
Specifications are subject to change without notice.  
Weight and dimensions are approximate.

---

---

**Matsushita Electric Industrial Co., Ltd.**  
Central P.O. Box 288, Osaka 530-91, Japan